

Partner for Performance



# Metal Bellows Couplings



RINGFEDER® GWB

EN 03.2023

Product Paper & Tech Paper





**Machine Building**



**Aviation & Aerospace**



**Process Technology**

# Welcome

## Your System Partner for Drive and Damping Technology

We say what we mean and mean what we say.

We see things from our customers' perspective.

We are considerate of our employees and their families as well as of our environment and society.



**Movement**



**Energy**



**Extraction**

RINGFEDER POWER TRANSMISSION is the international market leader in niche markets for drive and damping technology. We develop, manufacture and supply superior Shaft-Hub Connections, Damping Components, Couplings, Brake Systems and Bearing Housings for highest functionality and durability requirements in a wide range of technology sectors worldwide. Not only do we always provide our ambitious customers with competent advice based on over 100 years of experience and expertise, but also realize need-based, application-oriented solutions together with them that guarantee safe, failure-free and economic machine and plant operation – with our aspiration to be **Partner for Performance**.

**Our customer promise for your specific use case:**

- Excellent know-how for maximum performance and reliability
- Best cost-benefit ratio
- Short reaction times and high product availability



**Quality & Expertise**  
*One century of competence and experience*

**Reliability & Trust**  
*From the requirement to the optimum result*

**Customer  
 Benefit**

**Digital & Online**  
*Always find the right information instantly*

**Anytime & Anywhere**  
*Locally on-site for you worldwide*

## Quality & Expertise

One century of competence and experience

As pioneer and market leader for premium systems and components of drive and damping technology, we stand for outstanding professional competence, superior product and service quality as well as excellent customer focus. For your advantage, we consistently combine highest quality standards, continuous optimization and profound consulting – no matter how, where and when forces must be transmitted or damped.

## Reliability & Trust

From the requirement to the optimum result

Whether customized special design or proven standard type, highly specific individual or holistic system solution: As a competent, professional and service-oriented partner, we support and accompany you from the initial clarification of your requirements to the successful completion of your purpose – and, of course, also beyond.



# Your Projects, Our Drive

## Anytime & Anywhere

Locally on-site for you worldwide

---

Thanks to national and international development, manufacturing and sales locations as well as a worldwide service and partner network, we are at your side around the globe directly and locally with qualified technical support and fast product availability – around the clock, seven days a week, of course also and particularly in urgent maintenance and repair cases.

## Digital & Online

Always find the right information instantly

---

Discover the latest company and product information, download CAD models, brochures and data sheets, use our calculation and selection program for shaft-hub connections, arrange a video consultation appointment with one of our specialists and much more – quickly, easily, with no obligation and at any time. Convince yourself on our website at [www.ringfeder.com](http://www.ringfeder.com).

## Metal Bellows Couplings

### Introduction

Backlash-free Metal Bellows Couplings are used in the sector of mechanical engineering, where a torque or a rotary motion has to be transmitted from shaft to shaft in highest accuracy of angle.

- Pumps with axial and vertical drives
- High dynamic portal drives
- Spindle lifting units
- Linear units
- Packaging machines
- Machine tools
- Special machines

### Characteristics of Metal Bellows Couplings

- Backlash-free transmission of torque
- High torsional stiffness, precision of transmission of rotational angle
- Different torsional stiffness
- Compact design, low moment of inertia
- Metal bellows made of stainless steel
- Simple and safe assembly
- Compensation of radial, axial and angular misalignment
- Free of wear, maintenance-free, no downtimes
- Not sensitive to temperatures between -30 °C and +100 °C
- Nominal torques between 0,1 – 5000 Nm

### Premium Metal Bellows Couplings with 20% higher torques!



### Advantages

- 100% inspection and traceability through individual marking
- Higher torques at same dimensions
- Compact design
- Extended bore ranges
- Customer-specific solutions
- Higher safety in application, e.g. no wrong screw tightening torques

 <p><b>RINGFEDER® GWB AK</b></p> <p>Metal bellows coupling with inner conical hub</p>	 <p><b>RINGFEDER® GWB AKD</b></p> <p>Metal bellows coupling with clamping hubs</p>	 <p><b>RINGFEDER® GWB AKN</b></p> <p>Metal bellows coupling with clamping hubs, short length and higher torsional stiffness</p>	 <p><b>RINGFEDER® GWB CKN</b></p> <p>Metal bellows coupling with flange</p>
 <p><b>RINGFEDER® GWB DKN</b></p> <p>Miniature metal bellows coupling with clamping hubs</p>	 <p><b>RINGFEDER® GWB EKN</b></p> <p>Miniature metal bellows coupling with radial set screws</p>	 <p><b>RINGFEDER® GWB PKA</b></p> <p>Metal bellows coupling with axial pluggable clamping hub</p>	 <p><b>RINGFEDER® GWB Z5106</b></p> <p>Metal bellows coupling with clamping in split hub design</p>



#### Disclaimer of liability

All technical details and notes are non-binding and cannot be used as a basis for legal claims. The user is obligated to determine whether the represented products meet his requirements.

We reserve the right carry out modifications at any time in the interests of technical progress.

# Design / Sample calculation

## Design / Product information

Backlash-free, torsionally stiff metal bellows couplings are ready to install when delivered. The metal bellows are made of stainless steel, all other parts are made of aluminum or steel and partly have environmental friendly protective coating. The shaft tolerance should be within the fit tolerance "g6" or "h7". The power transmission between the coupling hub and the shaft is generated by compression and friction between the contact surfaces. Special attention must be paid to the tightening torque of the retaining screws as well as the perfect condition of the surfaces. The contact surfaces must be free of oil and grease and have a roughness depth of  $R_{\text{tmax.}} 16 \mu$  for the shaft. Versions with keyway are available. The torques indicated can be guaranteed only in compliance with all given advice. Otherwise cut backs have to be accepted.

$$T \geq K \cdot T_{AS} \cdot \frac{J_{\text{Masch}}}{J_{\text{Mot}} + J_{\text{Masch}}} = [\text{Nm}]$$

## Dimensioning in accordance with the torque

Metal bellows couplings are mostly selected according to the transmissible torque. In all cases the torque of the selected coupling size must be higher than the regular transmitted torque. This generally applies to the use of servo motors, whose acceleration moment in both positive and negative directions exceeds the nominal moment. For the use of metal bellows couplings which are fitted in controlled, high dynamic drives, the following dimensioning values (K) have proven to be reliable in practice:

- K = 1,5 for evenly shaped movements
- K = 2 for unevenly shaped movements
- K = 2,5 – 4 for jerky movements

For servo drives within tool making machines, the values for

K = 1,5 – 2 should be used.

We would be pleased to design your metal bellows coupling for you. Feel free to use our experience and know-how for your success. Give us a call!

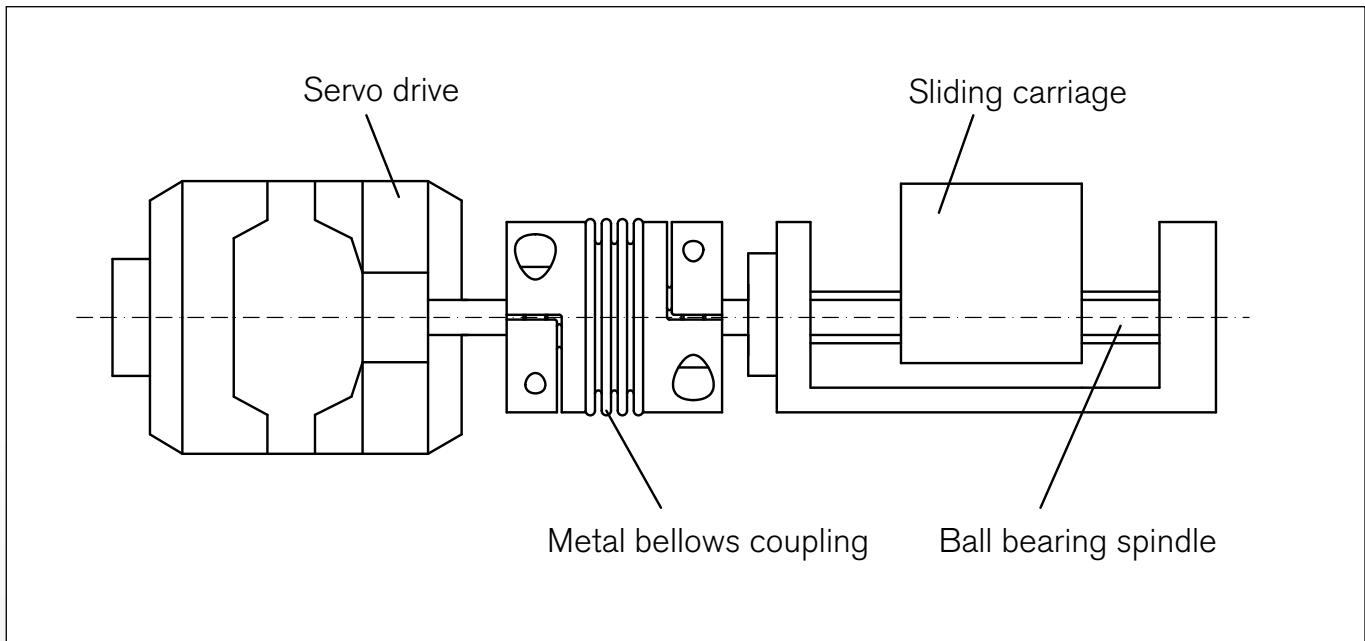



# Design in consideration of dynamic torsional stiffness

Although metal bellows couplings are backlash-free and torsion-rigid, it should not be ignored that they link two rotating masses. In adverse cases the couplings can act like torsion spring with high stiffness. The regulating oscillation of the drives and the harmonic oscillation in the armature current of the motor therefore must never be within the range of the mechanical resonance frequency. In practise the resonance frequency "f<sub>res</sub>" must be twice as high as the excitation frequency of the drive.

The dynamic torsional stiffness C<sub>Tdyn</sub> was selected so that it would not be within the range of parasitic oscillation of most applications. Various levels of torsional stiffness are available as standard versions.

We would be pleased to design your metal bellows couplings for you. Feel free to use our experience and know-how for your success. Give us a call!

## Calculation for the application of a metal bellows coupling in a machine tool drive

### Drive related data:

Servo motor I FT 5104  
 (Peak torque T<sub>AS</sub> = 160 Nm,  
 Moment of inertia J<sub>Mot</sub> = 18,3 · 10<sup>-3</sup> Kgm<sup>2</sup>)

The low moment of inertia for the metal bellows coupling is disregared.  
 K = Load factor, impulse factor selected for this drive K = 2;

### Output data:

Machine tool  
 (Moment of inertia of ball screw and slide: J<sub>Masch</sub> = 17 · 10<sup>-3</sup> Kgm<sup>2</sup>)

$$f_{res} = \frac{1}{2\pi} \sqrt{C_{Tdyn} \cdot \frac{J_{Mot} + J_{Masch}}{J_{Mot} \cdot J_{Masch}}} = [\text{Hz}]$$

## Design according to torque:

### Coupling selection:

AKD 200, T = 240 Nm, C<sub>Tdyn</sub> = 120 x 10<sup>3</sup> Nm/rad

The metal bellows coupling is dimensioned sufficient, since 240 Nm > 154 Nm

$$T \geq K \cdot T_{AS} \cdot \frac{J_{Masch}}{J_{Mot} + J_{Masch}} = 2 \cdot 160 \text{ Nm} \cdot \frac{17 \cdot 10^{-3} \text{ Kgm}^2}{(18,3 + 17) \cdot 10^{-3} \text{ Kgm}^2} = 154 \text{ Nm}$$

## Design according the resonance frequency:

The arithmetic calculation is clearly higher than the expected resonance frequency.

Usually for the most established nc-machine tools this value is between 150 to 350 Hz.

$$f_{res} = \frac{1}{2\pi} \sqrt{C_{Tdyn} \cdot \frac{J_{Mot} + J_{Masch}}{J_{Mot} \cdot J_{Masch}}} = \frac{1}{2\pi} \sqrt{120000 \text{ Nm/rad} \cdot \frac{0,0183 + 0,017 \text{ Kgm}^2}{0,0183 \cdot 0,017 \text{ Kgm}^2}} = 587 \text{ Hz}$$

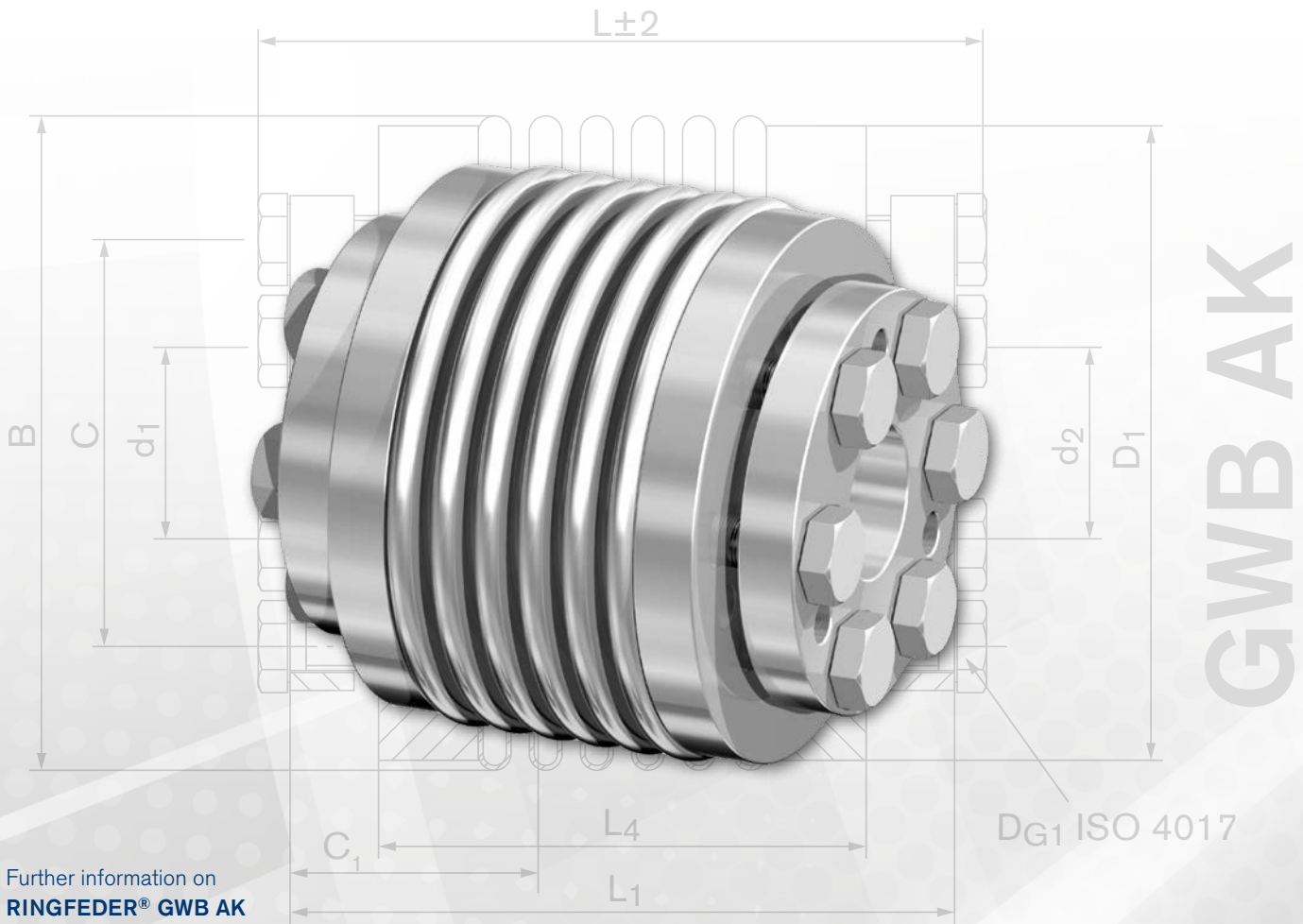

Further information on **RINGFEDER®** **GWB AK** on [www.ringfeder.com](http://www.ringfeder.com)

**GWB AK**

## Metal bellows coupling with inner conical hub

Metal bellows **RINGFEDER®** **GWB AK** have been designed especially for the backlash-free transmission of high torques of up to 5,000 Nm. The elements are mounted on driver and driven components with tapered clamping bushings. Depending on the required size, the coupling will be produced with hubs made of aluminum or steel. In addition, **GWB AK** guarantees for perfect concentric running.

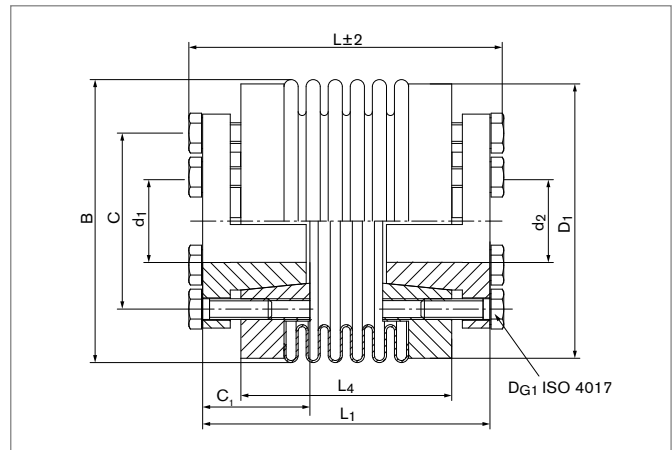

### Characteristics

- Metal bellows made of stainless steel, conical bushings made of steel
- Hubs up to size 500 made of aluminum, sizes 800 – 5000 hubs made of steel
- The shaft tolerance should be within the fit tolerance "g6" or "h7"
- The contact surfaces have to be free from oil and grease
- Optional special design in stainless steel

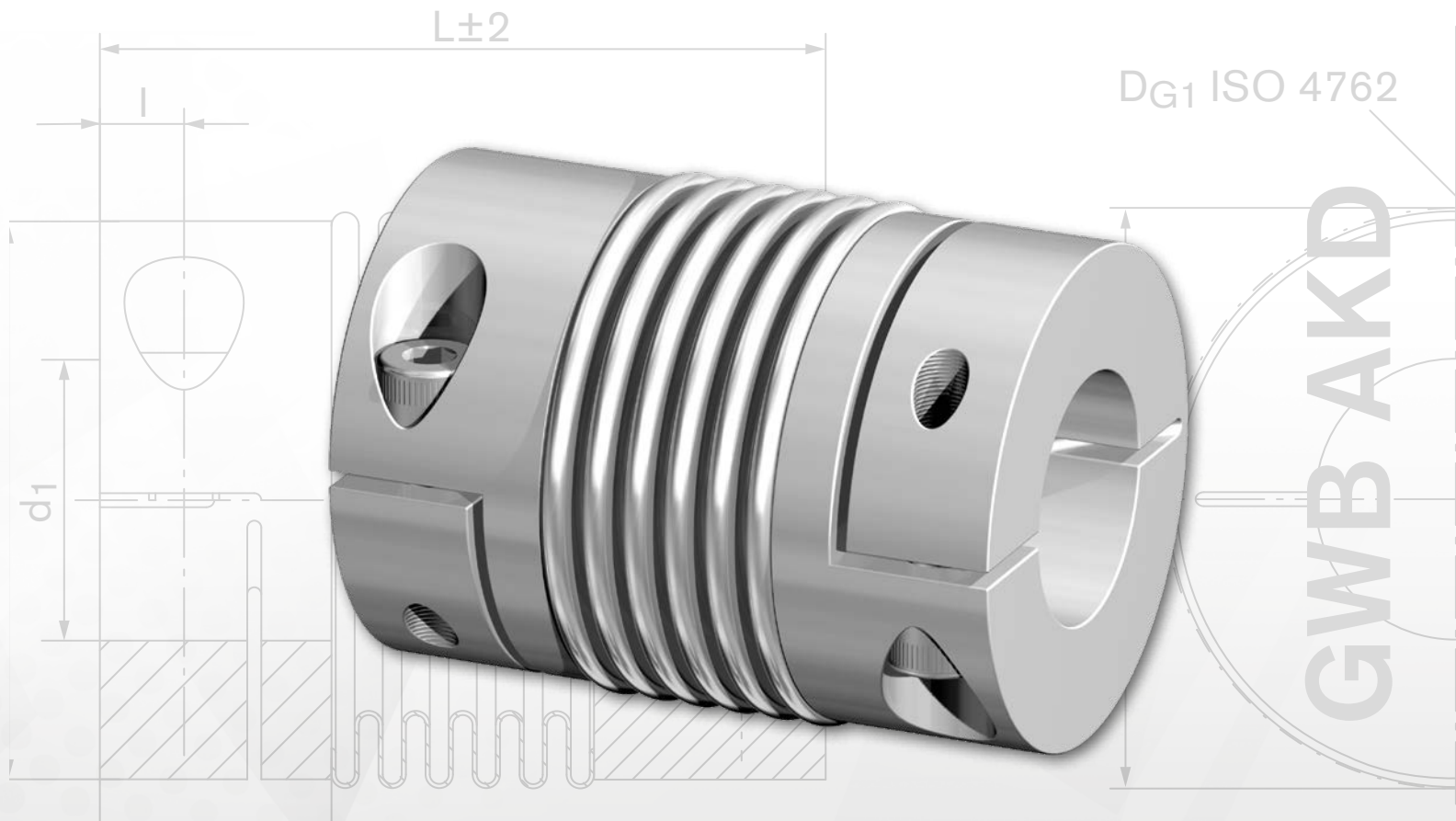

Further information on  
**RINGFEDER®** **GWB AKD**  
 on [www.ringfeder.com](http://www.ringfeder.com)

## Metal bellows coupling with clamping hubs

**RINGFEDER®** **GWB AKD** offers the traditional metal bellows coupling which can be used for a wide range of applications. Its core characteristics are the backlash-free transmission of torque, high torsional stiffness, and excellent compensation of angular, axial and radial misalignments. Operational safety and easy assembly are two more factors speaking in favour of **GWB AKD**.

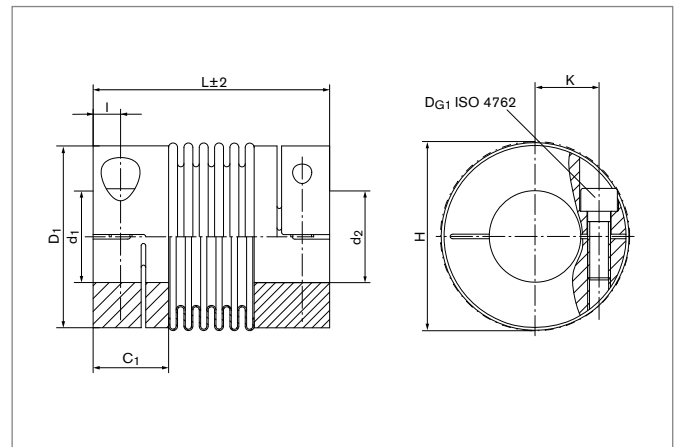

### Characteristics

- Metal bellows made of stainless steel, hubs made of aluminum/hubs from size 800 made of steel
- The shaft tolerance should be within the fit tolerance "g6" or "h7"
- The contact surfaces have to be free from oil and grease
- Optional designs with keyway DIN 6885-1
- Optional special design in stainless steel
- Other sizes available on request



Further information on  
**RINGFEDER®** **GWB AKN**  
 on [www.ringfeder.com](http://www.ringfeder.com)

## Metal bellows coupling with clamping hubs, short length and higher torsional stiffness

The metal bellows couplings from the **RINGFEDER®** **GWB AKN** series boast RINGFEDER®'s trusted quality and increased torsional stiffness. The reduced shafts in the element guarantee for high stiffness while at the same time compensating angular, axial and radial misalignments. The shaft connection is established by means of clamping hubs on both sides.

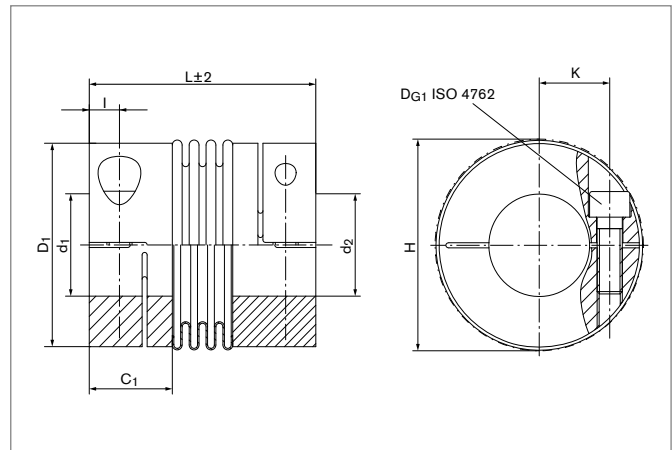

### Characteristics

- Metal bellows made of stainless steel, hubs made of aluminum
- The shaft tolerance should be within the fit tolerance "g6" or "h7"
- The contact surfaces have to be free from oil and grease
- Optional designs with keyway DIN 6885-1
- Optional special design in stainless steel

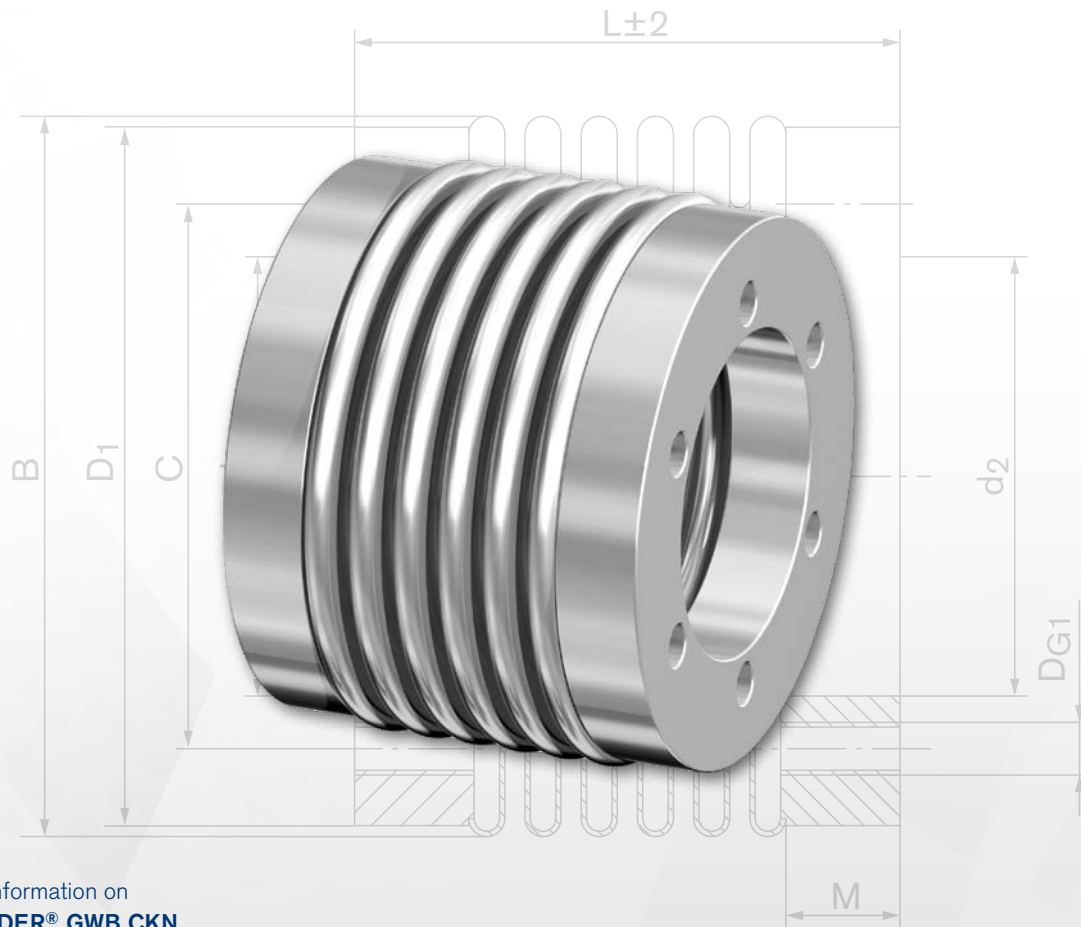

**GWB CKN**

Further information on  
**RINGFEDER®** **GWB CKN**  
 on [www.ringfeder.com](http://www.ringfeder.com)

## Metal bellows coupling with flange

**RINGFEDER®** **GWB CKN** is the production series which grants customers a maximum of application liberties. The flange mounting offers manifold possibilities to establish a connection with the element or add hubs, flanges and fittings. Depending on the chosen model, GWB CKN has been designed for very high torques of up to 5,000 Nm.

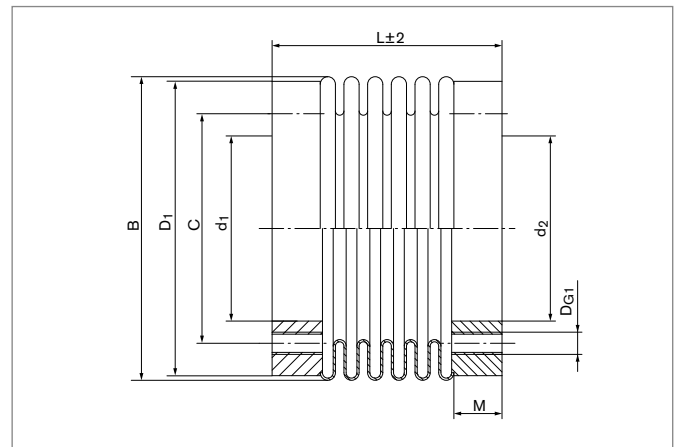

### Characteristics

- Metal bellows made of stainless steel
- Hubs up to size 500 made of aluminum, sizes 800 – 5000 hubs made of steel
- The contact surfaces have to be free from oil and grease
- Optional special design in stainless steel

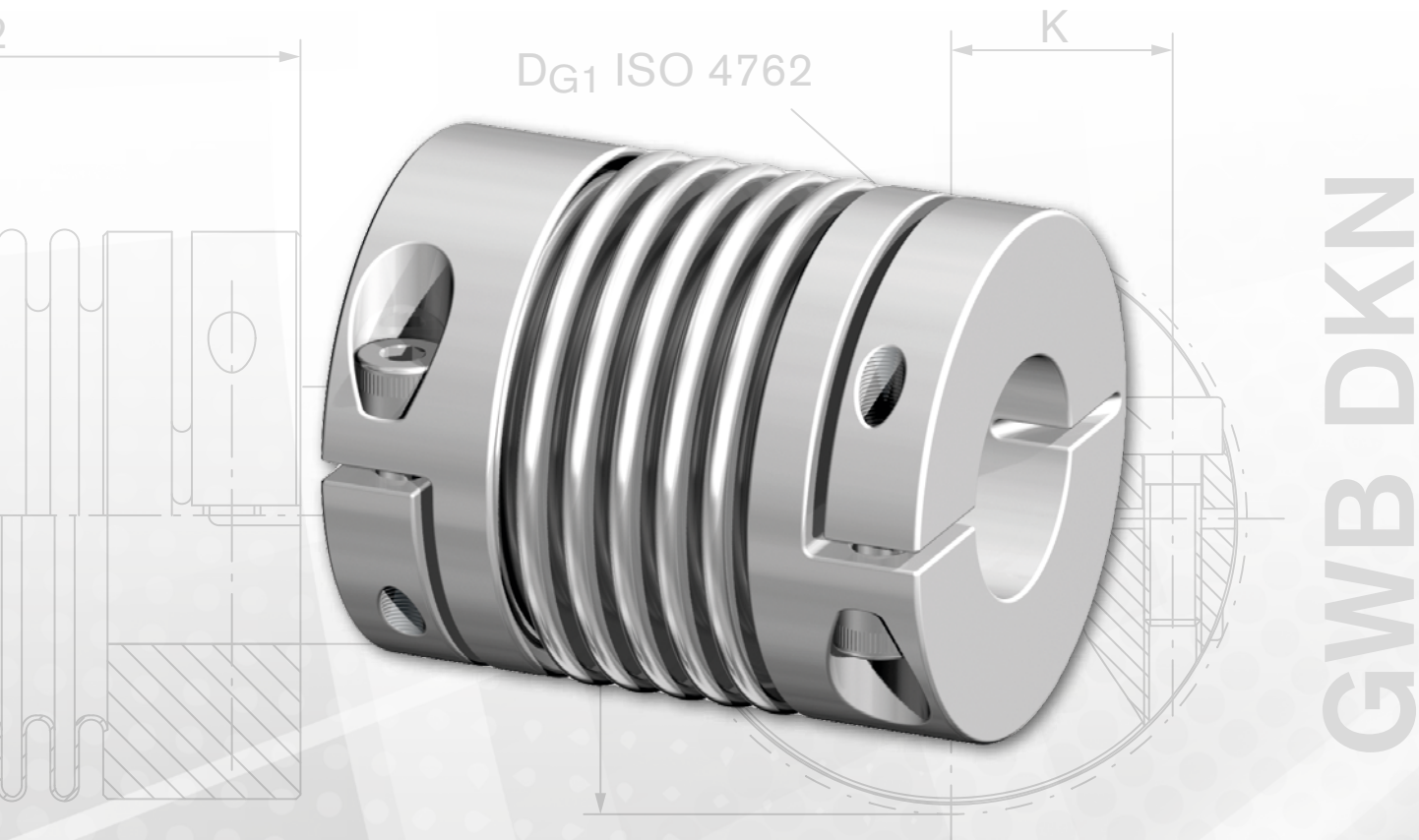

Further information on **RINGFEDER®** **GWB DKN** on [www.ringfeder.com](http://www.ringfeder.com)

## Miniature metal bellows coupling with clamping hubs

Thanks to its compact design, the **RINGFEDER®** **GWB DKN** Metal Bellows Coupling is perfectly qualified for backlash-free connections in confined spaces. It is mounted on driver and driven components by means of clamping hubs. High-quality build and material guarantee for maximum durability.

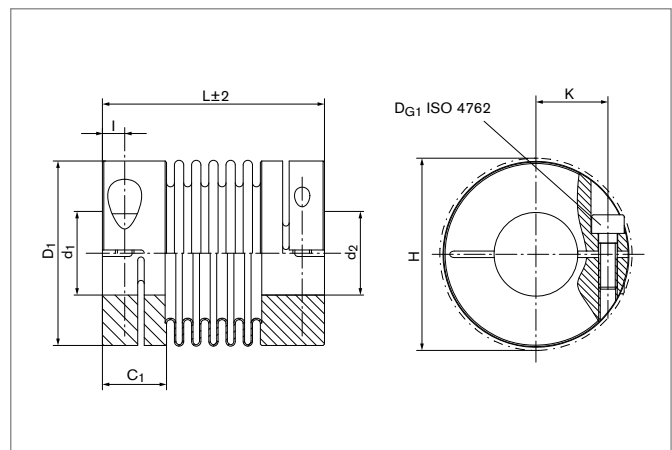

### Characteristics

- Metal bellows made of stainless steel, hubs made of aluminum
- The shaft tolerance should be within the fit tolerance "g6" or "h7"
- The contact surfaces have to be free from oil and grease
- Optional designs with keyway DIN 6885-1
- Optional special design in stainless steel



Further information on  
**RINGFEDER®** **GWB EKN**  
 on [www.ringfeder.com](http://www.ringfeder.com)

## Miniature metal bellows coupling with radial set screws

**RINGFEDER®** **GWB EKN** is a backlash-free metal bellows coupling which boasts a very compact shape. The miniature coupling is connected to the shaft by means of radial set screws instead of a clamping hub. The element can be used in many different areas and displays all its advantages when misalignments between driver and driven components have to be compensated.

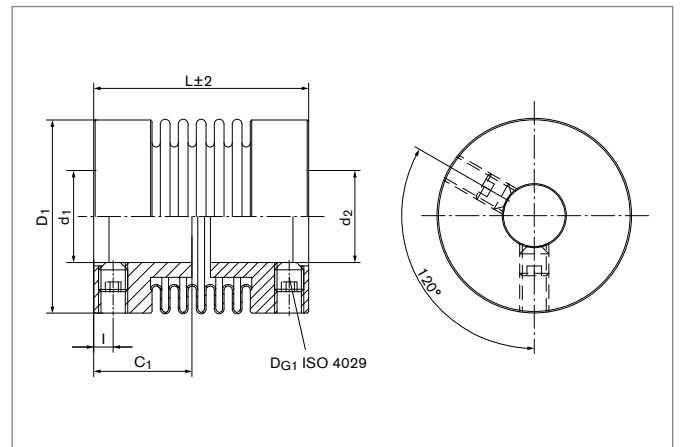

### Characteristics

- Metal bellows made of stainless steel, hubs made of aluminum
- The shaft tolerance should be within the fit tolerance "g6" or "h7"
- The contact surfaces have to be free from oil and grease
- Optional designs with keyway DIN 6885-1

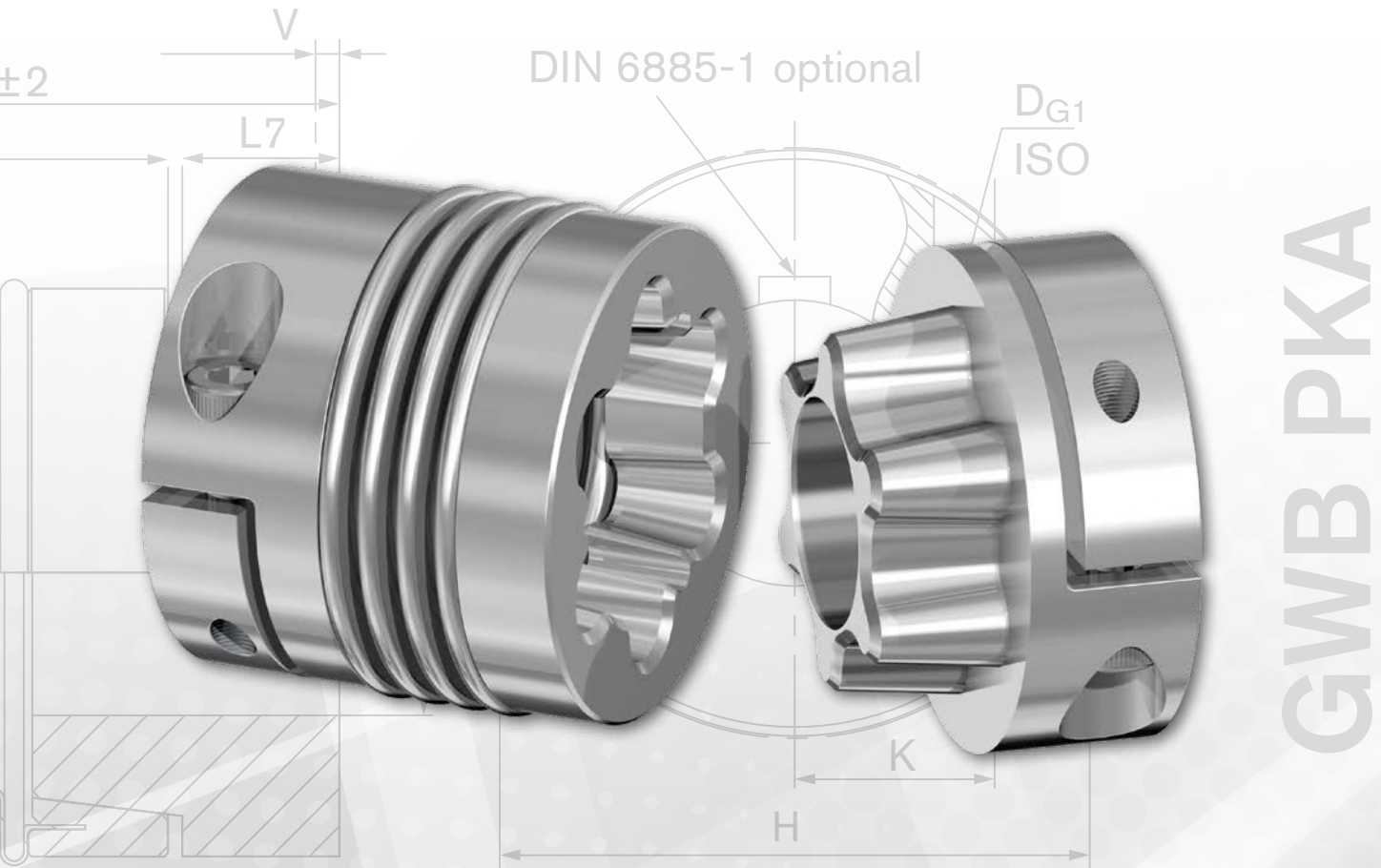

Further information on **RINGFEDER®** **GWB PKA** on [www.ringfeder.com](http://www.ringfeder.com)

## Metal bellows coupling with axial pluggable clamping hub

Backlash-free Metal Bellows Coupling **RINGFEDER®** **GWB PKA** with clamping hub.

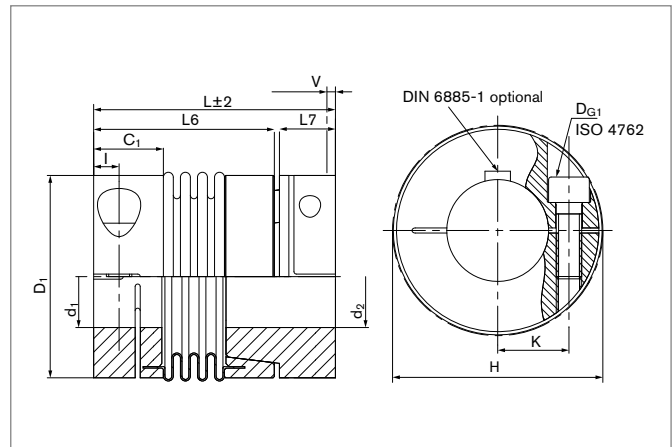

### Characteristics

- Metal bellows made of stainless steel, hubs made of aluminum
- Backlash-free and torsional stiffness
- High-tensile pluggable hub
- High power performance
- Wear- and maintenance-free
- Axial pluggable
- Easy mounting and dismantling



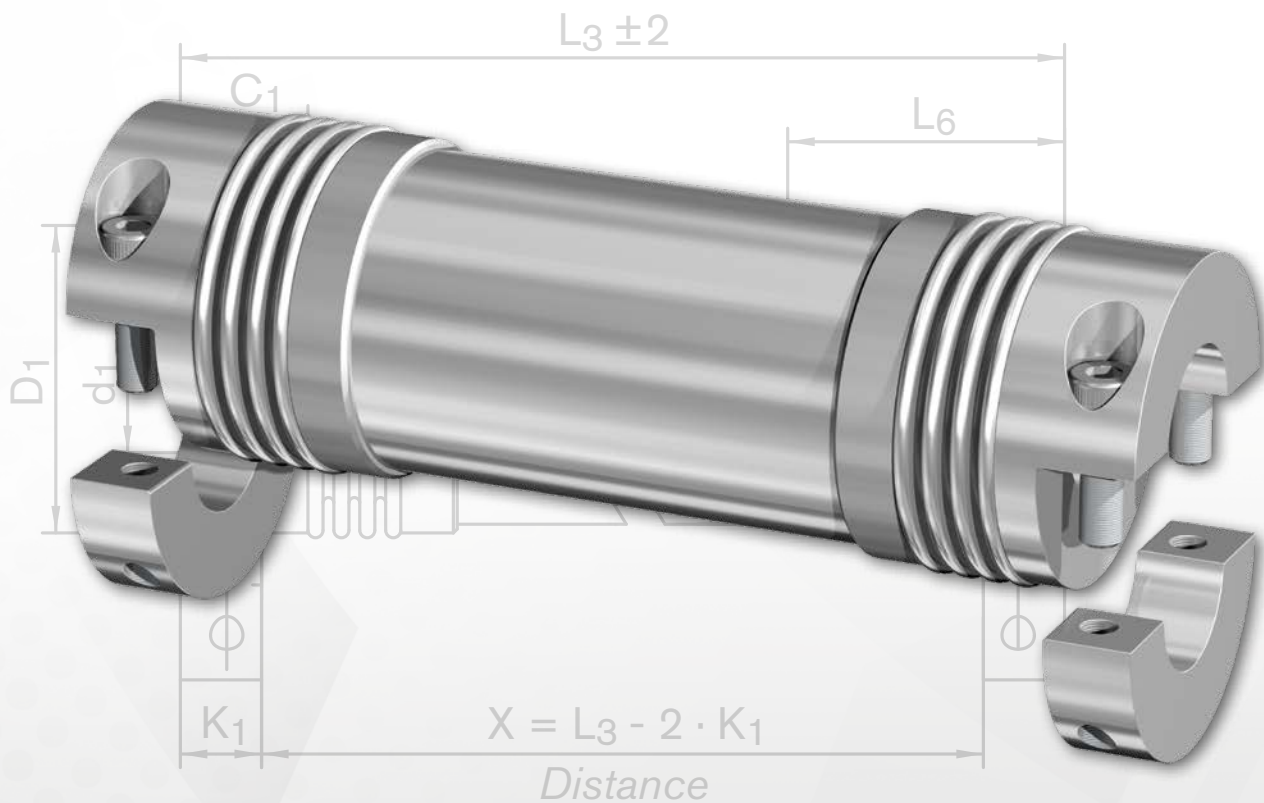

**GWB Z5106**

Further information on  
**RINGFEDER®** **GWB Z5106**  
on [www.ringfeder.com](http://www.ringfeder.com)

## Metal bellows coupling with clamping in split hub design

The **RINGFEDER®** **GWB Z5106** is a backlash-free metal bellows coupling in line shaft design. Because of the double cardanic system, the compensating of high shaft displacements are possible. The clamping hubs in split hub design can be mounted lateral at the aligned shaft extensions.

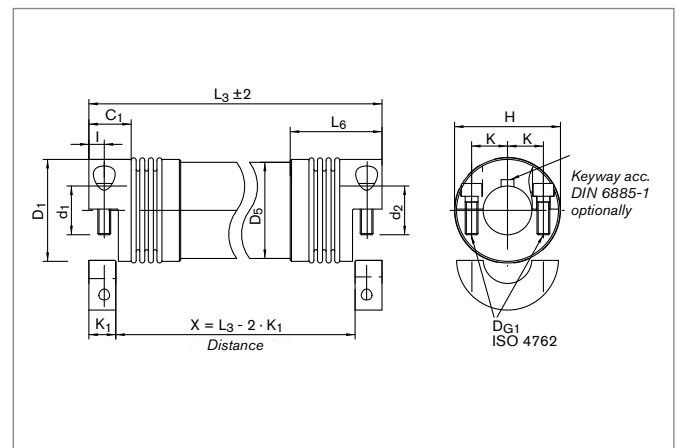

### Characteristics

- Metal bellows made of stainless steel, hubs made of aluminum
- Precision line shaft made of aluminum
- Optional line shaft made of CFK
- Backlash-free and torsionally rigid
- The shaft tolerance should be within the fit tolerance "g6" or "h7"
- The contact surfaces have to be free from oil and grease
- Optional designs with keyway DIN 6885-1



PORTATA MASSIMA  
MAX USEFUL LOAD  
30 KG.



# Metal Bellows Couplings **RINGFEDER®** **GWB**

## Tables & Values

The equations and recommendations in the chapters 'Design / Sample calculation' and 'Design in consideration of dynamic torsional stiffness' must be taken into account to determine the coupling size.

$L \pm 2$

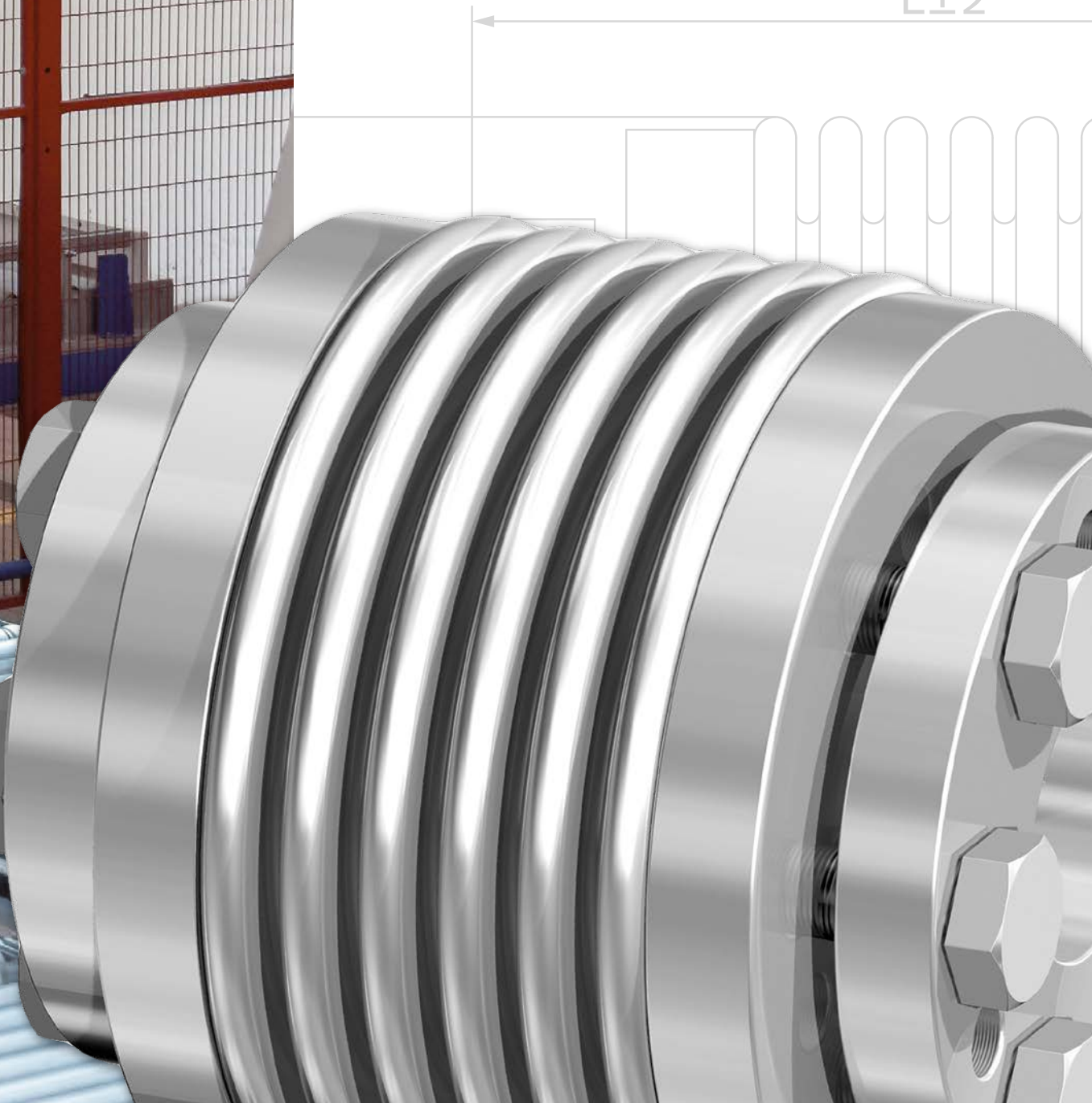

# Metal Bellows Couplings

## RINGFEDER® GWB AK

Metal bellows coupling with inner conical hub

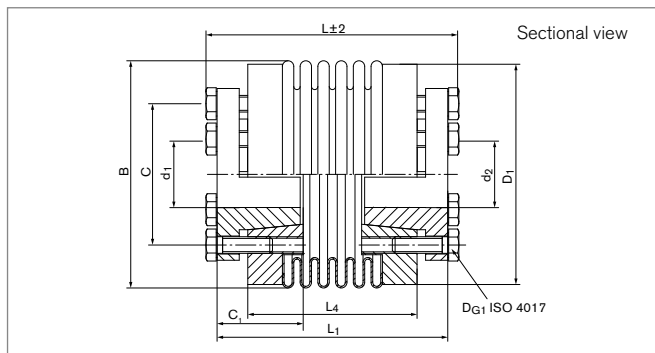

Size	L	C	d <sub>1</sub> ;d <sub>2</sub> min-max	B	D <sub>1</sub>	C <sub>1</sub>	L <sub>1</sub>	L <sub>4</sub>
	mm	mm	mm	mm	mm	mm	mm	mm
30	52/60	31	9 - 20	56	55	20	45/53	30/38
60	63/73	37	12 - 25	66	64	25	55/65	35/46
80	79/91	51	15 - 35	82	80	30	72/83	49/61
150	79/91	51	15 - 35	82	80	30	72/84	49/61
200	80/93	51/56	15 - 42	90	90	30	72/85	50/63
300	93/104	62/75	15 - 50	110	110	33	80/93	56/67
500	102/113	75/80	24 - 55	122	119	38	94/105	61/72
800	170	92/100	30 - 70	157	140	60	150	110
1400	170	92/100	35 - 70	157	140	60	150	110
3000	191	100/125	50 - 80	199	180	60	171	131
5000	199	100/125	60 - 90	250	230	65	179	139

Transmission of the couplings transmissible torque T can no longer be guaranteed for certain with borings < dmin. Types with borings < dmin, however, can be supplied.

Moment of inertia and weight (mass) are calculated with reference to the largest bore size.

Size	T	n <sub>max</sub>	C <sub>Tdyn</sub>	C <sub>r</sub>	C <sub>a</sub>	ΔK <sub>a</sub>	ΔK <sub>w</sub>	ΔK <sub>r</sub>	J	D <sub>G1</sub>	T <sub>A1</sub>	Gw
	Nm	1/min	10 <sup>3</sup> Nm/rad	N/mm	N/mm	mm	degree	mm	10 <sup>-3</sup> kgm <sup>2</sup>	mm	Nm	kg
30	36	11000	35/25	720/220	50/30	0,4/0,5	1,0/1,5	0,1/0,2	0,15	6 x M4	3	0,281
60	72	9100	75/50	1100/330	90/55	0,4/0,5	1,0/1,5	0,1/0,2	0,24	6 x M6	8,5	0,482
80	96	7000	130/75	1200/400	80/55	0,4/0,5	1,0/1,5	0,2	0,65	6 x M6	10	0,846
150	180	7000	150/100	2000/600	150/85	0,4/0,5	1,0/1,5	0,2	0,65	6 x M6	14	0,846
200	240	6700	170/120	2500/450	150/85	0,4/0,5	1,0/1,5	0,2	0,87	6 x M6	14	1,005
300	360	5200	318/500/280	6300/1500	235/280/150	0,4/0,5	1,0/1,5	0,2	2,33	6 x M8	18	1,915
500	600	4600	680/310	8800/1000	100/85	0,5/1,0	1,0/1,5	0,2	5,73	6 x M8	26	2,448
800	800	3700	760	510	190	1,0	1,5	0,2	26,10	6 x M16	50	9,978
1400	1400	3700	1300	710	280	1,0	1,5	0,2	26,10	6 x M16	80	9,202
3000	3000	2800	2800	8060	880	1,0	1,5	0,2	86,83	6 x M16	130	14,57
5000	5000	2800	4800	9190	737	1,0	1,5	0,2	170,30	6 x M16	210	24,3

To continue see next page

## Metal Bellows Couplings RINGFEDER® GWB AK

### Transmissible torque T [Nm]

Size	Ø9	Ø10	Ø12	Ø14	Ø15	Ø18	Ø20	Ø24	Ø28	Ø32	Ø38	Ø44	Ø48	Ø50	Ø58	Ø60	Ø65	Ø70	Ø75	Ø80	Ø85	Ø90
30	36	36	36	36	36	36	36	---	---	---	---	---	---	---	---	---	---	---	---	---	---	---
60	---	---	72	72	72	72	72	72	---	---	---	---	---	---	---	---	---	---	---	---	---	---
80	---	---	---	---	96	96	96	96	96	96	---	---	---	---	---	---	---	---	---	---	---	---
150	---	---	---	---	180	180	180	180	180	180	---	---	---	---	---	---	---	---	---	---	---	---
200	---	---	---	---	240	240	240	240	240	240	240	---	---	---	---	---	---	---	---	---	---	---
300	---	---	---	---	290	350	360	360	360	360	360	360	360	---	---	---	---	---	---	---	---	---
500	---	---	---	---	---	---	---	600	600	600	600	600	600	600	---	---	---	---	---	---	---	---
800	---	---	---	---	---	---	---	---	800	800	800	800	800	800	800	800	800	800	800	---	---	---
1400	---	---	---	---	---	---	---	---	---	1400	1400	1400	1400	1400	1400	1400	1400	1400	1400	---	---	---
3000	---	---	---	---	---	---	---	---	---	---	---	---	3000	3000	3000	3000	3000	3000	3000	3000	3000	---
5000	---	---	---	---	---	---	---	---	---	---	---	---	---	---	5000	5000	5000	5000	5000	5000	5000	5000

### Explanation

<b>L</b> = Total length	<b>L<sub>4</sub></b> = Length of coupling piece (without conical bushing)	<b>ΔK<sub>w</sub></b> = Max. permissible angular misalignment
<b>C</b> = Pitch circle diameter	<b>T</b> = Transmissible torque at given T <sub>A</sub>	<b>ΔK<sub>r</sub></b> = Max. permissible radial misalignment
<b>d<sub>1</sub>; d<sub>2min</sub></b> = Min. bore diameter d <sub>1</sub> /d <sub>2</sub>	<b>n<sub>max</sub></b> = Max. rotation speed	<b>J</b> = Total moment of inertia
<b>d<sub>1</sub>; d<sub>2max</sub></b> = Max. bore diameter d <sub>1</sub> /d <sub>2</sub>	<b>C<sub>tdyn</sub></b> = Dynamic torsional stiffness	<b>n<sub>sc1</sub></b> = Quantity of screws D <sub>G1</sub>
<b>B</b> = Bellow outer diameter	<b>C<sub>r</sub></b> = Radial spring stiffness	<b>D<sub>G1</sub></b> = Thread
<b>D<sub>1</sub></b> = Outer diameter	<b>C<sub>a</sub></b> = Axial spring stiffness	<b>T<sub>A1</sub></b> = Tightened torque of clamping screw D <sub>G1</sub>
<b>C<sub>1</sub></b> = Guided length in hub bore	<b>ΔK<sub>a</sub></b> = Max. permissible axial misalignment	<b>Gw</b> = Weight
<b>L<sub>1</sub></b> = Length of coupling		

### Ordering example

Series/Size	Length	Bore diameter d <sub>1</sub>	Bore diameter d <sub>2</sub>	Further details
AK 150	79	30	35	*

\* Stainless steel

Further information on  
**RINGFEDER® GWB AK**  
 on [www.ringfeder.com](http://www.ringfeder.com)

#### Disclaimer of liability

All technical details and notes are non-binding and cannot be used as a basis for legal claims. The user is obligated to determine whether the represented products meet his requirements. We reserve the right carry out modifications at any time in the interests of technical progress.

# Metal Bellows Couplings

## RINGFEDER® GWB AKD

### Metal bellows coupling with clamping hubs

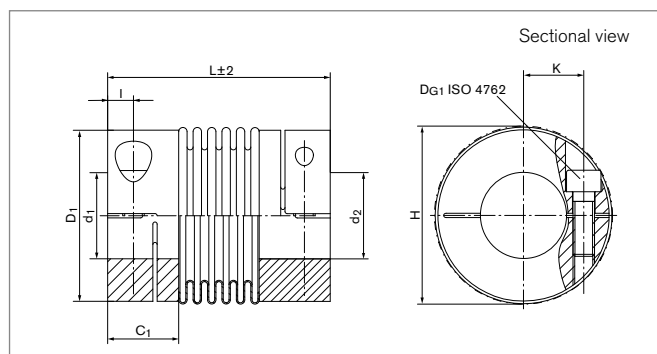
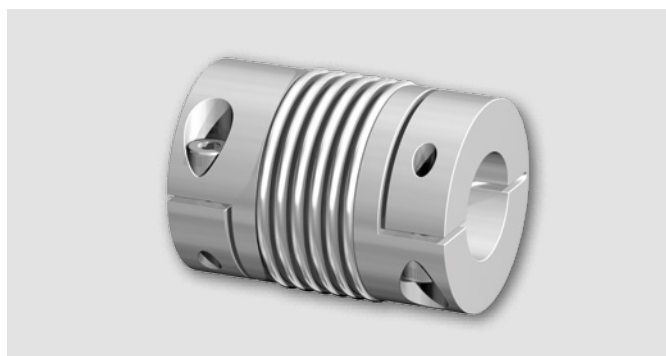

Size	L	d <sub>1</sub> ;d <sub>2</sub> min-max	C <sub>1</sub>	D <sub>1</sub>	H	I	K
	mm	mm	mm	mm	mm	mm	mm
18	71	8 - 26	19,2	45	47	6	18
30	73	10 - 30	24,1	55	56	8	20
60	89	12 - 35	28,6	64	67	10	24
80	103	14 - 42	32,4	80	84	12	28
150	103	14 - 42	32,4	80	84	12	28
200	113	22 - 46	36,9	90	93	13	31
300	115	24 - 60	36,9	110	110	13	39
500	122	35 - 64	40,4	119	122	15	43
800	140	40 - 75	45,2	132	139	17	48

Transmission of the couplings transmissible torque T can not longer be guaranteed for certain with borings < dmin. Types with borings < dmin, however, can be supplied.

Moment of inertia and weight (mass) are calculated with reference to the largest bore size.

Size	T	n <sub>max</sub>	C <sub>r</sub>	C <sub>a</sub>	C <sub>Tdyn</sub>	ΔK <sub>a</sub>	ΔK <sub>w</sub>	ΔK <sub>r</sub>	J	D <sub>G1</sub>	T <sub>A1</sub>	Gw
	Nm	1/min	N/mm	N/mm	10 <sup>3</sup> Nm/rad	mm	degree	mm	10 <sup>-3</sup> kgm <sup>2</sup>	mm	Nm	kg
18	22	12700	85	40	6	0,5	1,5	0,2	0,06	1 x M5	6	0,143
30	36	10200	220	30	25	0,5	1,5	0,2	0,1	1 x M6	12	0,263
60	75	8600	330	55	50	0,5	1,5	0,2	0,3	1 x M8	30	0,434
80	95	6800	400	55	75	0,5	1,5	0,2	0,9	1 x M10	60	0,792
150	180	6800	600	85	100	0,5	1,5	0,2	0,9	1 x M10	85	0,792
200	240	6300	450	85	120	0,5	1,5	0,2	1,5	1 x M12	100	1,117
300	360	5900	1500	150	280	0,5	1,5	0,2	3,2	1 x M12	120	1,495
500	600	4900	1000	85	310	1	1,5	0,2	4,9	1 x M14	190	2,038
800	800	5000	6200	100	780	3,5	1,5	0,35	17,5	2 x M16	250	6,06

To continue see next page

## Metal Bellows Couplings RINGFEDER® GWB AKD

### Transmissible torque T [Nm]

Size	Ø8	Ø9	Ø10	Ø11	Ø12	Ø14	Ø15	Ø16	Ø18	Ø20	Ø25	Ø30	Ø35	Ø40	Ø45	Ø50	Ø55	Ø60	Ø64	Ø70	Ø75
18	18	20	22	22	22	22	22	22	22	22	22	---	---	---	---	---	---	---	---	---	---
30	---	---	36	36	36	36	36	36	36	36	36	36	---	---	---	---	---	---	---	---	---
60	---	---	---	---	75	75	75	75	75	75	75	75	75	---	---	---	---	---	---	---	---
80	---	---	---	---	---	---	95	95	95	95	95	95	95	95	---	---	---	---	---	---	---
150	---	---	---	---	---	---	180	180	180	180	180	180	180	180	---	---	---	---	---	---	---
200	---	---	---	---	---	---	---	---	---	---	240	240	240	240	240	---	---	---	---	---	---
300	---	---	---	---	---	---	---	---	---	---	360	360	360	360	360	360	360	360	---	---	---
500	---	---	---	---	---	---	---	---	---	---	---	---	600	600	600	600	600	600	600	---	---
800	---	---	---	---	---	---	---	---	---	---	---	---	---	800	800	800	800	800	800	800	800

### Explanation

<b>L</b> = Total length	<b>K</b> = Distance shaft axis - clamping screw axis	<b>ΔK<sub>r</sub></b> = Max. permissible radial misalignment
<b>d<sub>1</sub>; d<sub>2min</sub></b> = Min. bore diameter d <sub>1</sub> /d <sub>2</sub>	<b>T</b> = Transmissible torque at given T <sub>A</sub>	<b>J</b> = Total moment of inertia
<b>d<sub>1</sub>; d<sub>2max</sub></b> = Max. bore diameter d <sub>1</sub> /d <sub>2</sub>	<b>n<sub>max</sub></b> = Max. rotation speed	<b>n<sub>sc1</sub></b> = Quantity of screws D <sub>G1</sub>
<b>C<sub>1</sub></b> = Guided length in hub bore	<b>C<sub>r</sub></b> = Radial spring stiffness	<b>D<sub>G1</sub></b> = Thread
<b>D<sub>1</sub></b> = Outer diameter	<b>C<sub>a</sub></b> = Axial spring stiffness	<b>T<sub>A1</sub></b> = Tightened torque of clamping screw D <sub>G1</sub>
<b>H</b> = Clearance diameter	<b>C<sub>Tdyn</sub></b> = Dynamic torsional stiffness	<b>G<sub>w</sub></b> = Weight
<b>I</b> = Distance between center screw hole and hub end	<b>ΔK<sub>a</sub></b> = Max. permissible axial misalignment	
	<b>ΔK<sub>w</sub></b> = Max. permissible angular misalignment	

### Ordering example

Series/Size	Bore diameter d <sub>1</sub>	Bore diameter d <sub>2</sub>	Further details
AKD 150	30	35	*

\* Keyway or stainless steel

Further information on  
**RINGFEDER® GWB AKD**  
 on [www.ringfeder.com](http://www.ringfeder.com)

#### Disclaimer of liability

All technical details and notes are non-binding and cannot be used as a basis for legal claims. The user is obligated to determine whether the represented products meet his requirements. We reserve the right carry out modifications at any time in the interests of technical progress.

# Metal Bellows Couplings

## RINGFEDER® GWB AKN

Metal bellows coupling with clamping hubs, short length and higher torsional stiffness

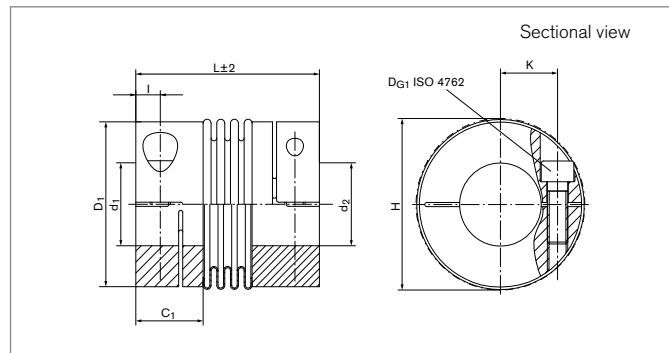

Size	L	d <sub>1</sub> ;d <sub>2</sub> min-max	d <sub>1k</sub> ;d <sub>2k</sub> min-max	C <sub>1</sub>	D <sub>1</sub>	H	I	K
	mm	mm	mm	mm	mm	mm	mm	mm
18	63	8 - 26	8 - 26	19,2	45	48	6	18
30	65	10 - 30	10 - 30	24,1	55	56	8	20
60	78	12 - 35	12 - 35	28,6	64	67	10	24
80	90	14 - 42	14 - 42	32,4	80	84	12	28
150	90	14 - 42	14 - 42	32,4	80	84	12	28
200	99	22 - 46	22 - 46	36,9	90	93	13	31
300	104	24 - 60	24 - 60	36,9	110	110	13	39
500	111	35 - 64	35 - 64	40,4	119	122	15	43

Transmission of the couplings transmissible torque T can not longer be guaranteed for certain with borings < dmin. Types with borings < dmin, however, can be supplied.

Moment of inertia and weight (mass) are calculated with reference to the largest bore size.

Size	T	n <sub>max</sub>	C <sub>r</sub>	C <sub>a</sub>	C <sub>Tdyn</sub>	ΔK <sub>a</sub>	ΔK <sub>w</sub>	ΔK <sub>r</sub>	J	D <sub>G1</sub>	T <sub>A1</sub>	G <sub>w</sub>
	Nm	1/min	N/mm	N/mm	10 <sup>3</sup> Nm/rad	mm	degree	mm	10 <sup>-3</sup> kgm <sup>2</sup>	mm	Nm	kg
18	22	12700	200	50	8	0,5	1,5	0,2	0,05	1 x M5	6	0,133
30	36	10200	720	50	35	0,4	1,0	0,1	0,11	1 x M6	12	0,245
60	75	8600	1100	90	75	0,4	1,0	0,1	0,29	1 x M8	30	0,406
80	95	6800	1200	80	130	0,4	1,0	0,2	0,87	1 x M10	60	0,742
150	180	6800	2000	150	150	0,4	1,0	0,2	0,87	1 x M10	85	0,742
200	240	6300	2500	150	170	0,4	1,0	0,2	1,44	1 x M12	100	1,054
300	360	5900	6300	280	500	0,4	1,0	0,2	3,00	1 x M12	120	1,434
500	600	4900	8800	100	680	0,5	1,0	0,2	4,70	1 x M14	190	1,949

To continue see next page



## Metal Bellows Couplings RINGFEDER® GWB AKN

### Transmissible torque T [Nm]

Size	Ø8	Ø9	Ø10	Ø11	Ø12	Ø13	Ø15	Ø16	Ø18	Ø20	Ø22	Ø25	Ø28	Ø30	Ø35	Ø40	Ø45	Ø50	Ø55	Ø60	Ø64
18	18	20	22	22	22	22	22	22	22	22	22	22	---	---	---	---	---	---	---	---	---
30	---	---	36	36	36	36	36	36	36	36	36	36	36	36	---	---	---	---	---	---	---
60	---	---	---	---	75	75	75	75	75	75	75	75	75	75	75	---	---	---	---	---	---
80	---	---	---	---	---	---	95	95	95	95	95	95	95	95	95	95	---	---	---	---	---
150	---	---	---	---	---	---	180	180	180	180	180	180	180	180	180	180	---	---	---	---	---
200	---	---	---	---	---	---	---	---	---	---	240	240	240	240	240	240	240	---	---	---	---
300	---	---	---	---	---	---	---	---	---	---	---	360	360	360	360	360	360	360	360	360	---
500	---	---	---	---	---	---	---	---	---	---	---	---	---	---	600	600	600	600	600	600	600

### Explanation

<b>L</b>	= Total length	<b>I</b>	= Distance between center screw hole and hub end	<b>ΔK<sub>w</sub></b>	= Max. permissible angular misalignment
<b>d<sub>1</sub>;d<sub>2min</sub></b>	= Min. bore diameter d <sub>1</sub> /d <sub>2</sub>	<b>K</b>	= Distance shaft axis - clamping screw axis	<b>ΔK<sub>r</sub></b>	= Max. permissible radial misalignment
<b>d<sub>1</sub>;d<sub>2max</sub></b>	= Max. bore diameter d <sub>1</sub> /d <sub>2</sub>	<b>T</b>	= Transmissible torque at given T <sub>A</sub>	<b>J</b>	= Total moment of inertia
<b>d<sub>1k</sub>;d<sub>2kmin</sub></b>	= Min. bore diameter d <sub>1</sub> /d <sub>2</sub> with keyway acc. to DIN 6885-1	<b>n<sub>max</sub></b>	= Max. rotation speed	<b>n<sub>sc1</sub></b>	= Quantity of screws D <sub>G1</sub>
<b>d<sub>1k</sub>;d<sub>2kmax</sub></b>	= Max. bore diameter d <sub>1</sub> /d <sub>2</sub> with keyway acc. to DIN 6885-1	<b>C<sub>r</sub></b>	= Radial spring stiffness	<b>D<sub>G1</sub></b>	= Thread
<b>C<sub>1</sub></b>	= Guided length in hub bore	<b>C<sub>a</sub></b>	= Axial spring stiffness	<b>T<sub>A1</sub></b>	= Tightened torque of clamping screw D <sub>G1</sub>
<b>D<sub>1</sub></b>	= Outer diameter	<b>C<sub>Tdyn</sub></b>	= Dynamic torsional stiffness	<b>G<sub>w</sub></b>	= Weight
<b>H</b>	= Clearance diameter	<b>ΔK<sub>a</sub></b>	= Max. permissible axial misalignment		

### Ordering example

Series/Size	Bore diameter d <sub>1</sub>	Bore diameter d <sub>2</sub>	Further details
AKN 150	30	35	*

\* Keyway or stainless steel

Further information on  
**RINGFEDER® GWB AKN**  
 on [www.ringfeder.com](http://www.ringfeder.com)

#### Disclaimer of liability

All technical details and notes are non-binding and cannot be used as a basis for legal claims. The user is obligated to determine whether the represented products meet his requirements. We reserve the right carry out modifications at any time in the interests of technical progress.

# Metal Bellows Couplings

## RINGFEDER® GWB CKN

Metal bellows coupling with flange

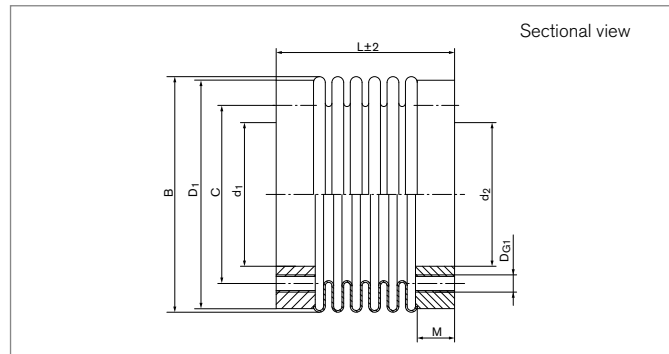

Size	L	d <sub>1</sub>	d <sub>2</sub>	B	C	D <sub>1</sub>	M
	mm	mm	mm	mm	mm	mm	mm
18	36	22	22	46	31	46	6
18	44	22	22	46	31	46	6
30	30	28	28	56	37	55	7
30	38	28	28	56	37	55	7
60	41	38	38	66	46	64	10
60	51	38	38	66	46	64	10
80	52	50	50	82	62	80	13
80	62	50	50	82	62	80	13
150	52	50	50	82	62	80	13
150	62	50	50	82	62	80	13
200	51	50	50	90	62	90	13
200	63	50	50	90	62	90	13
300	55	65	65	110	80	109	13
300	66	65	65	110	80	109	13
500	61	70	70	122	94	119	16
500	72	70	70	122	94	119	16
800	130	85	85	157	110	152	18
1400	130	85	85	157	110	152	18
3000	130	100	100	199	140	180	25
5000	143	145	145	250	190	230	25

To continue see next page

### Metal Bellows Couplings RINGFEDER® GWB CKN

Size	T	$n_{max}$	$C_{Tdyn}$	$\Delta K_a$	$\Delta K_w$	$\Delta K_r$	J	$D_{G1}$	$T_{A1}$	Gw
	Nm	1/min	$10^3$ Nm/rad	mm	degree	mm	$10^{-3}kgm^2$	mm	Nm	kg
18	22	13900	8	0,5	1,5	0,2	0,05	6 x M5	5,9	0,06
18	22	13900	6	0,5	1,5	0,2	0,05	6 x M5	5,9	0,06
30	36	11000	35	0,4	1,0	0,1	0,09	6 x M5	5,9	0,12
30	36	11000	25	0,5	1,5	0,2	0,09	6 x M5	5,9	0,12
60	75	9000	75	0,4	1,0	0,1	0,16	6 x M6	10	0,19
60	75	9000	50	0,5	1,5	0,2	0,16	6 x M6	10	0,19
80	96	7100	130	0,4	1,0	0,2	0,43	6 x M6	10	0,36
80	96	7100	75	0,5	1,5	0,2	0,43	6 x M6	10	0,36
150	180	7100	150	0,4	1,0	0,2	0,43	6 x M6	15	0,36
150	180	7100	100	0,5	1,5	0,2	0,43	6 x M6	15	0,36
200	240	6600	170	0,4	1,0	0,2	0,80	6 x M6	18	0,48
200	240	6600	120	0,5	1,5	0,2	0,80	6 x M6	18	0,48
300	360	5200	500	0,4	1,0	0,2	1,70	6 x M8	25	0,59
300	360	5200	280	0,5	1,5	0,2	1,70	6 x M8	25	0,59
500	600	4600	680	0,5	1,0	0,2	2,30	6 x M8	36	0,88
500	600	4600	310	1,0	1,5	0,2	2,30	6 x M8	36	0,88
800	960	3700	760	1,0	1,5	0,2	11,00	6 x M16	210	3,74
1400	1680	3700	1300	1,0	1,5	0,2	11,00	6 x M16	210	3,73
3000	3000	3700	2800	1,0	1,5	0,2	47,00	6 x M20	365	7,80
5000	5000	3000	4800	1,0	1,5	0,2	119,00	8 x M20	365	11,74

### Explanation

<b>L</b> = Total length	<b><math>n_{max}</math></b> = Max. rotation speed	<b><math>n_{Sc1}</math></b> = Quantity of screws $D_{G1}$
<b><math>d_1</math></b> = Inner diameter	<b><math>C_{Tdyn}</math></b> = Dynamic torsional stiffness	<b><math>D_{G1}</math></b> = Thread
<b><math>d_2</math></b> = Inner diameter	<b><math>C_r</math></b> = Radial spring stiffness	<b><math>T_{A1}</math></b> = Tightened torque of clamping screw $D_{G1}$
<b>B</b> = Bellow outer diameter	<b><math>C_a</math></b> = Axial spring stiffness	<b>Gw</b> = Weight
<b>C</b> = Pitch circle diameter	<b><math>\Delta K_a</math></b> = Max. permissible axial misalignment	
<b><math>D_1</math></b> = Outer diameter	<b><math>\Delta K_w</math></b> = Max. permissible angular misalignment	
<b>M</b> = Max. depth of thread	<b><math>\Delta K_r</math></b> = Max. permissible radial misalignment	
<b>T</b> = Transmissible torque at given $T_A$	<b>J</b> = Total moment of inertia	

### Ordering example

Series/Size	Length	Further details
CKN 150	52	*

\* Stainless steel

Further information on  
**RINGFEDER® GWB CKN**  
 on [www.ringfeder.com](http://www.ringfeder.com)

#### Disclaimer of liability

All technical details and notes are non-binding and cannot be used as a basis for legal claims. The user is obligated to determine whether the represented products meet his requirements. We reserve the right carry out modifications at any time in the interests of technical progress.

# Metal Bellows Couplings

## RINGFEDER® GWB DKN

Miniature metal bellows coupling with clamping hubs

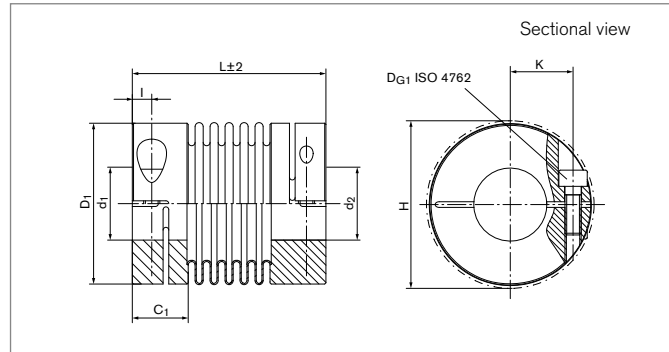

Size	L	d <sub>1</sub> ;d <sub>2</sub> min-max	d <sub>1k</sub> ;d <sub>2k</sub> min-max	C <sub>1</sub>	D <sub>1</sub>	H	I	K
	mm	mm	mm	mm	mm	mm	mm	mm
4	21	3 - 8	6 - 8	6,5	16	18	2,4	5
4	24	3 - 8	6 - 8	6,5	16	18	2,4	5
4	28	3 - 8	6 - 8	6,5	16	18	2,4	5
9	23	3 - 8	6 - 8	6,5	16	18	2,4	5
9	26	3 - 8	6 - 8	6,5	16	18	2,4	5
9	30	3 - 8	6 - 8	6,5	16	18	2,4	5
15	26	3 - 10	6 - 10	8,3	20	21	3	7
15	30	3 - 10	6 - 10	8,3	20	21	3	7
20	32	3 - 14	6 - 14	10,4	25	27	3,5	9
20	38	3 - 14	6 - 14	10,4	25	27	3,5	9
20	42	3 - 14	6 - 14	10,4	25	27	3,5	9
45	41	5 - 17	6 - 17	12,5	33	34	4,5	12
45	50	5 - 17	6 - 17	12,5	33	34	4,5	12
100	47	5 - 24	6 - 24	13,2	40	42	4,8	16
100	57	5 - 24	6 - 24	13,2	40	42	4,8	16

Transmission of the couplings transmissible torque T can not longer be guaranteed for certain with borings < dmin. Types with borings < dmin, however, can be supplied.

Moment of inertia and weight (mass) are calculated with reference to the largest bore size.

To continue see next page

### Metal Bellows Couplings RINGFEDER® GWB DKN

Size	T	n <sub>max</sub>	C <sub>Tdyn</sub>	C <sub>r</sub>	C <sub>a</sub>	ΔK <sub>a</sub>	ΔK <sub>w</sub>	ΔK <sub>r</sub>	J	D <sub>G1</sub>	T <sub>A1</sub>	G <sub>w</sub>
	Nm	1/min	10 <sup>3</sup> Nm/rad	N/mm	N/mm	mm	degree	mm	10 <sup>-3</sup> kgm <sup>2</sup>	mm	Nm	kg
4	0,5	15000	0,25	128	18	0,2	1,2	0,10	0,0026	1 x M2	0,3	0,005
4	0,5	15000	0,19	54	13	0,3	2,0	0,15	0,0026	1 x M2	0,3	0,006
4	0,5	15000	0,15	26	11	0,4	2,0	0,20	0,0026	1 x M2	0,3	0,007
9	1,1	15000	0,50	187	36	0,2	1,2	0,10	0,0026	1 x M2	0,3	0,006
9	1,1	15000	0,38	82	27	0,3	2,0	0,15	0,0029	1 x M2	0,3	0,007
9	1,1	15000	0,30	42	22	0,4	2,0	0,20	0,0032	1 x M2	0,3	0,008
15	1,75	15000	0,75	139	23	0,25	1,2	0,10	0,011	1 x M2,5	0,8	0,012
15	1,75	15000	0,70	81	12	0,4	2,0	0,15	0,012	1 x M2,5	0,8	0,014
20	2,4	15000	1,50	147	18	0,3	1,2	0,10	0,025	1 x M3	1,5	0,020
20	2,4	15000	1,30	96	14	0,4	2,0	0,20	0,027	1 x M3	1,5	0,022
20	2,4	15000	1,00	46	9	0,5	2,0	0,25	0,028	1 x M3	1,5	0,024
45	5,5	15000	6,50	444	47	0,3	1,2	0,10	0,098	1 x M4	3	0,058
45	5,5	15000	4,00	108	29	0,5	2,0	0,20	0,103	1 x M4	3	0,062
100	12	15000	8,10	361	46	0,4	1,2	0,15	0,231	1 x M4	3	0,060
100	12	15000	6,70	193	34	0,5	2,0	0,25	0,250	1 x M4	3	0,070

### Transmissible torque T [Nm]

Size	Ø3	Ø4	Ø5	Ø6	Ø7	Ø8	Ø9	Ø10	Ø11	Ø12	Ø13	Ø14	Ø15	Ø16	Ø17	Ø18	Ø19	Ø20	Ø21	Ø22	Ø24	
4	0,5	0,5	0,5	0,5	0,5	0,5	---	---	---	---	---	---	---	---	---	---	---	---	---	---	---	---
9	0,5	0,5	0,5	0,5	0,5	0,5	---	---	---	---	---	---	---	---	---	---	---	---	---	---	---	---
15	1,5	1,75	1,75	1,75	1,75	1,75	1,75	1,75	---	---	---	---	---	---	---	---	---	---	---	---	---	---
20	1,7	2,3	2,4	2,4	2,4	2,4	2,4	2,4	2,4	2,4	2,4	---	---	---	---	---	---	---	---	---	---	---
45	---	---	5,5	5,5	5,5	5,5	5,5	5,5	5,5	5,5	5,5	5,5	5,5	5,5	5,5	---	---	---	---	---	---	---
100	---	---	7	8	9	10,5	12	12	12	12	12	12	12	12	12	12	12	12	12	12	12	12

To continue see next page

## Metal Bellows Couplings RINGFEDER® GWB DKN

### Explanation

<b>L</b>	= Total length	<b>I</b>	= Distance between center screw hole and hub end	$\Delta K_a$	= Max. permissible axial misalignment
<b>d<sub>1</sub>;d<sub>2min</sub></b>	= Min. bore diameter d <sub>1</sub> /d <sub>2</sub>	<b>K</b>	= Distance shaft axis - clamping screw axis	$\Delta K_w$	= Max. permissible angular misalignment
<b>d<sub>1</sub>;d<sub>2max</sub></b>	= Max. bore diameter d <sub>1</sub> /d <sub>2</sub>	<b>T</b>	= Transmissible torque at given T <sub>A</sub>	$\Delta K_r$	= Max. permissible radial misalignment
<b>d<sub>1k</sub>;d<sub>2kmin</sub></b>	= Min. bore diameter d <sub>1</sub> /d <sub>2</sub> with keyway acc. to DIN 6885-1	<b>n<sub>max</sub></b>	= Max. rotation speed	<b>J</b>	= Total moment of inertia
<b>d<sub>1k</sub>;d<sub>2kmax</sub></b>	= Max. bore diameter d <sub>1</sub> /d <sub>2</sub> with keyway acc. to DIN 6885-1	<b>C<sub>Tdyn</sub></b>	= Dynamic torsional stiffness	<b>n<sub>Sc1</sub></b>	= Quantity of screws D <sub>G1</sub>
<b>C<sub>1</sub></b>	= Guided length in hub bore	<b>C<sub>r</sub></b>	= Radial spring stiffness	<b>D<sub>G1</sub></b>	= Thread
<b>D<sub>1</sub></b>	= Outer diameter	<b>C<sub>a</sub></b>	= Axial spring stiffness	<b>T<sub>A1</sub></b>	= Tightened torque of clamping screw D <sub>G1</sub>
<b>H</b>	= Clearance diameter			<b>Gw</b>	= Weight

### Ordering example

Series/Size	Length	Bore diameter d <sub>1</sub>	Bore diameter d <sub>2</sub>	Further details
DKN 20	42	6	10	*

\* Keyway or stainless steel

Further information on  
**RINGFEDER® GWB DKN**  
 on [www.ringfeder.com](http://www.ringfeder.com)

#### Disclaimer of liability

All technical details and notes are non-binding and cannot be used as a basis for legal claims. The user is obligated to determine whether the represented products meet his requirements. We reserve the right carry out modifications at any time in the interests of technical progress.

# Metal Bellows Couplings

## RINGFEDER® GWB EKN

### Miniature metal bellows coupling with radial set screws

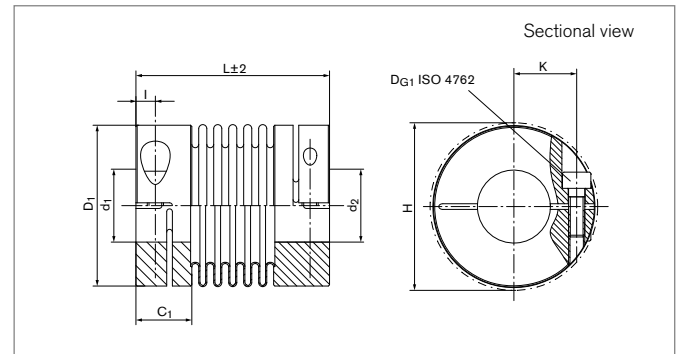

Size	L	d <sub>1</sub> ;d <sub>2</sub> min-max	d <sub>1k</sub> ;d <sub>2k</sub> min-max	C <sub>1</sub>	D <sub>1</sub>	I
	mm	mm	mm	mm	mm	mm
4	20	3 - 9	6 - 8	6	16	2
4	23	3 - 9	6 - 8	6	16	2
4	26	3 - 9	6 - 8	6	16	2
9	21	3 - 9	6 - 8	6	16	2
9	25	3 - 9	6 - 8	6	16	2
9	28	3 - 9	6 - 8	6	16	2
15	25	3 - 12	6 - 10	10	20	3
15	30	3 - 12	6 - 10	10	20	3
20	26	3 - 16	6 - 14	11	25	2
20	32	3 - 16	6 - 14	11	25	2
20	36	3 - 16	6 - 14	11	25	2
45	39	6 - 22	6 - 16	16	33	4
45	48	6 - 22	6 - 16	16	33	4
100	44	6 - 28	6 - 25	20	40	4
100	54	6 - 28	6 - 25	20	40	4

Transmission of the couplings transmissible torque T can not longer be guaranteed for certain with borings < d<sub>min</sub>. Types with borings < d<sub>min</sub>, however, can be supplied.

Moment of inertia and weight (mass) are calculated with reference to the largest bore size.

To continue see next page

### Metal Bellows Couplings RINGFEDER® GWB EKN

Size	T	n <sub>max</sub>	C <sub>Tdyn</sub>	C <sub>r</sub>	C <sub>a</sub>	ΔK <sub>a</sub>	ΔK <sub>w</sub>	ΔK <sub>r</sub>	J	D <sub>G1</sub>	T <sub>A1</sub>	G <sub>w</sub>
	Nm	1/min	10 <sup>3</sup> Nm/rad	N/mm	N/mm	mm	degree	mm	10 <sup>-3</sup> kgm <sup>2</sup>	mm	Nm	kg
4	0,5	15000	0,25	128	18	0,2	1,2	0,1	0,0002	1 x M3	0,5	0,005
4	0,5	15000	0,19	54	13	0,3	2,0	0,15	0,0002	1 x M3	0,5	0,006
4	0,5	15000	0,15	26	11	0,4	2,0	0,2	0,0002	1 x M3	0,5	0,007
9	1,1	15000	0,50	187	36	0,2	1,2	0,1	0,0002	1 x M3	0,5	0,006
9	1,1	15000	0,38	82	27	0,3	2,0	0,15	0,0002	1 x M3	0,5	0,007
9	1,1	15000	0,30	42	22	0,4	2,0	0,2	0,0003	1 x M3	0,5	0,008
15	1,75	15000	0,75	139	12	0,25	1,2	0,1	0,0008	2 x M4	1,5	0,012
15	1,75	15000	0,70	81	23	0,4	2,0	0,15	0,0008	2 x M4	1,5	0,014
20	2,4	15000	1,50	147	18	0,3	1,2	0,1	0,0014	2 x M3	1,5	0,016
20	2,4	15000	1,30	96	14	0,4	2,0	0,2	0,0016	2 x M3	1,5	0,018
20	2,4	15000	1,00	46	9	0,5	2,0	0,25	0,0017	2 x M3	1,5	0,020
45	5,5	15000	6,50	444	47	0,3	1,2	0,1	0,0068	2 x M6	3	0,048
45	5,5	15000	4,00	108	29	0,5	2,0	0,2	0,0073	2 x M6	3	0,052
100	12	15000	8,10	361	46	0,4	1,2	0,15	0,0200	2 x M6	3	0,048
100	12	15000	6,70	193	34	0,5	2,0	0,25	0,0220	2 x M6	3	0,058

### Transmissible torque T [Nm]

Size	Ø3	Ø4	Ø5	Ø6	Ø7	Ø8	Ø9	Ø10	Ø11	Ø12	Ø13	Ø14	Ø15	Ø16	Ø17	Ø18	Ø20	Ø22	Ø24	Ø26	Ø28	
4	0,5	0,5	0,5	0,5	0,5	0,5	0,5	---	---	---	---	---	---	---	---	---	---	---	---	---	---	---
9	0,9	0,7	1,1	1,1	1,1	1,1	1,1	---	---	---	---	---	---	---	---	---	---	---	---	---	---	---
15	1,75	1,75	1,75	1,75	1,75	1,75	1,75	1,75	1,75	1,75	---	---	---	---	---	---	---	---	---	---	---	---
20	2,4	2,4	2,4	2,4	2,4	2,4	2,4	2,4	2,4	2,4	2,4	2,4	2,4	2,4	---	---	---	---	---	---	---	---
45	---	---	---	5,5	5,5	5,5	5,5	5,5	5,5	5,5	5,5	5,5	5,5	5,5	5,5	5,5	5,5	5,5	---	---	---	---
100	---	---	---	7,3	8,5	9,7	11	12	12	12	12	12	12	12	12	12	12	12	12	12	12	12

To continue see next page



## Metal Bellows Couplings RINGFEDER® GWB EKN

### Explanation

<b>L</b>	= Total length	<b>I</b>	= Distance between center screw hole and hub end	$\Delta K_r$	= Max. permissible radial misalignment
<b>d<sub>1</sub>;d<sub>2min</sub></b>	= Min. bore diameter d <sub>1</sub> /d <sub>2</sub>	<b>T</b>	= Transmissible torque at given T <sub>A</sub>	<b>J</b>	= Total moment of inertia
<b>d<sub>1</sub>;d<sub>2max</sub></b>	= Max. bore diameter d <sub>1</sub> /d <sub>2</sub>	<b>n<sub>max</sub></b>	= Max. rotation speed	<b>n<sub>Sc1</sub></b>	= Quantity of screws D <sub>G1</sub>
<b>d<sub>1k</sub>;d<sub>2kmin</sub></b>	= Min. bore diameter d <sub>1</sub> /d <sub>2</sub> with keyway acc. to DIN 6885-1	<b>C<sub>Tdyn</sub></b>	= Dynamic torsional stiffness	<b>D<sub>G1</sub></b>	= Thread
<b>d<sub>1k</sub>;d<sub>2kmax</sub></b>	= Max. bore diameter d <sub>1</sub> /d <sub>2</sub> with keyway acc. to DIN 6885-1	<b>C<sub>r</sub></b>	= Radial spring stiffness	<b>T<sub>A1</sub></b>	= Tightened torque of clamping screw D <sub>G1</sub>
<b>C<sub>1</sub></b>	= Guided length in hub bore	<b>C<sub>a</sub></b>	= Axial spring stiffness	<b>Gw</b>	= Weight
<b>D<sub>1</sub></b>	= Outer diameter	$\Delta K_a$	= Max. permissible axial misalignment		
		$\Delta K_w$	= Max. permissible angular misalignment		

### Ordering example

Series/Size	Length	Bore diameter d <sub>1</sub>	Bore diameter d <sub>2</sub>	Further details
EKN 20	26	6	10	*

\* Keyway

Further information on  
**RINGFEDER® GWB EKN**  
 on [www.ringfeder.com](http://www.ringfeder.com)

#### Disclaimer of liability

All technical details and notes are non-binding and cannot be used as a basis for legal claims. The user is obligated to determine whether the represented products meet his requirements. We reserve the right carry out modifications at any time in the interests of technical progress.

# Metal Bellows Couplings

## RINGFEDER® GWB PKA

Metal bellows coupling with axial pluggable clamping hub

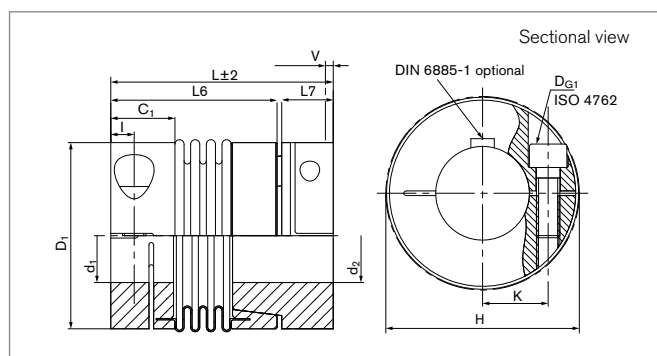

Size	L	d <sub>1</sub> min-max	d <sub>2</sub> min-max	d <sub>1k</sub> min-max	d <sub>2k</sub> min-max	C <sub>1</sub>	D <sub>1</sub>	H	I	K	L <sub>6</sub>	L <sub>7</sub>	V
	mm	mm	mm	mm	mm	mm	mm	mm	mm	mm	mm	mm	mm
0,4	26	3 - 8	3 - 6	-	-	6,5	16	17	2,4	5	20	5,5	0,4
0,4	28	3 - 8	3 - 6	-	-	6,5	16	17	2,4	5	22	5,5	0,4
0,4	32	3 - 8	3 - 6	-	-	6,5	16	17	2,4	5	26	5,5	0,4
0,9	27	3 - 8	3 - 6	-	-	6,5	16	17	2,4	5	20	5,5	0,4
0,9	30	3 - 8	3 - 6	-	-	6,5	16	17	2,4	5	22	5,5	0,4
0,9	34	3 - 8	3 - 6	-	-	6,5	16	17	2,4	5	26	5,5	0,4
1,5	32	3 - 10	3 - 10	6 - 10	-	8,3	20	21,5	3	7	23	8	0,5
1,5	36	3 - 10	3 - 10	6 - 10	-	8,3	20	21,5	3	7	27	8	0,5
2	37	3 - 14	3 - 12	6 - 14	6 - 10	10,4	25	27	3,5	9	28	8	0,5
2	43	3 - 14	3 - 12	6 - 14	6 - 10	10,4	25	27	3,5	9	34	8	0,5
2	47	3 - 14	3 - 12	6 - 14	6 - 10	10,4	25	27	3,5	9	38	8	0,5
4,5	49	5 - 17	5 - 16	6 - 17	6 - 12	12,5	33	34,5	4,5	11,5	36	11,5	0,7
4,5	57	5 - 17	5 - 16	6 - 17	6 - 12	12,5	33	34,5	4,5	11,5	44	11,5	0,7
10	55	5 - 24	5 - 20	6 - 24	6 - 16	13,2	40	41,5	4,8	15,5	42	11	1,0
10	66	5 - 24	5 - 20	6 - 24	6 - 16	13,2	40	41,5	4,8	15,5	53	11	1,0
18	59	10 - 26	8 - 21	10 - 26	8 - 17	16,2	45	47	5,5	17,5	39	17,5	0,5 - 1,0
18	67	10 - 26	8 - 21	10 - 26	8 - 17	16,2	45	47	5,5	17,5	47	17,5	0,5 - 1,0
30	70	10 - 30	10 - 25	10 - 30	10 - 22	20,6	55	56,5	7,5	20	48	19	0,5 - 1,0
30	78	10 - 30	10 - 25	10 - 30	10 - 22	20,6	55	56,5	7,5	20	56	19	0,5 - 1,0
60	85	14 - 34	12 - 32	14 - 34	12 - 30	23,1	64	66,5	9	22,5	62,5	20	0,5 - 1,5
60	96	14 - 34	12 - 32	14 - 34	12 - 30	23,1	64	66,5	9	22,5	73,5	20	0,5 - 1,5
150	95	17 - 42	15 - 40	17 - 42	15 - 38	26,8	80	83	10	28	71	22	0,5 - 1,5
150	107	17 - 42	15 - 40	17 - 42	15 - 38	26,8	80	83	10	28	83	22	0,5 - 1,5
300	112	24 - 60	24 - 56	24 - 60	24 - 44	32	110	110	12,5	39	72	37,5	0,5 - 1,5
300	123	24 - 60	24 - 56	24 - 60	24 - 44	32	110	110	12,5	39	84	37,5	0,5 - 1,5
500	134	35 - 64	35 - 64	35 - 64	35 - 50	40,4	119	119	15	43	91	40,5	0,5 - 2,0
500	145	35 - 64	35 - 64	35 - 64	35 - 50	40,4	119	119	15	43	102	40,5	0,5 - 2,0

To continue see next page

### Metal Bellows Couplings RINGFEDER® GWB PKA

Size	T	n <sub>max</sub>	C <sub>Tdyn</sub>	C <sub>r</sub>	C <sub>a</sub>	ΔK <sub>a</sub>	ΔK <sub>w</sub>	ΔK <sub>r</sub>	J	D <sub>G1</sub>	T <sub>A1</sub>	G <sub>w</sub>
	Nm	1/min	10 <sup>3</sup> Nm/rad	N/mm	N/mm	mm	degree	mm	10 <sup>-3</sup> kgm <sup>2</sup>	mm	Nm	kg
0,4	0,5	15000	0,25	128	18	0,2	1,2	0,1	0,0003	1 x M2	0,3	0,008
0,4	0,5	15000	0,19	54	13	0,3	2	0,15	0,0003	1 x M2	0,3	0,009
0,4	0,5	15000	0,15	26	11	0,4	2	0,2	0,0003	1 x M2	0,3	0,01
0,9	1,1	15000	0,5	187	36	0,2	1,2	0,1	0,0004	1 x M2	0,6	0,009
0,9	1,1	15000	0,38	82	27	0,3	2	0,15	0,0004	1 x M2	0,6	0,01
0,9	1,1	15000	0,3	42	22	0,4	2	0,2	0,0004	1 x M2	0,6	0,011
1,5	1,75	15000	0,75	139	23	0,25	1,2	0,1	0,001	1 x M2,5	0,8	0,015
1,5	1,75	15000	0,7	81	12	0,4	2	0,15	0,0011	1 x M2,5	0,8	0,017
2	2,4	15000	1,5	147	18	0,3	1,2	0,1	0,0028	1 x M3	1,5	0,028
2	2,4	15000	1,3	96	14	0,4	2	0,2	0,003	1 x M3	1,5	0,03
2	2,4	15000	1	46	9	0,5	2	0,25	0,0031	1 x M3	1,5	0,032
4,5	5,5	15000	6,5	444	47	0,3	1,2	0,1	0,0112	1 x M4	3	0,067
4,5	5,5	15000	4	108	29	0,5	2	0,2	0,0117	1 x M4	3	0,071
10	12	15000	8,1	361	46	0,4	1,2	0,15	0,0255	1 x M4	3	0,097
10	12	15000	6,7	193	34	0,5	2	0,25	0,0274	1 x M4	3	0,107
18	22	12700	8	200	50	0,4	1,2	0,15	0,0482	1 x M5	6	0,156
18	22	12700	6	85	40	0,5	1,5	0,2	0,0582	1 x M5	6	0,166
30	36	10200	35	720	50	0,4	1	0,1	0,1334	1 x M6	12	0,282
30	36	10200	25	220	30	0,5	1,5	0,2	0,1439	1 x M6	12	0,3
60	75	8600	75	1100	90	0,4	1	0,1	0,3228	1 x M8	30	0,482
60	75	8600	50	330	55	0,5	1,5	0,2	0,3328	1 x M8	30	0,51
150	180	6800	150	2000	150	0,4	1	0,2	0,8289	1 x M10	85	0,803
150	180	6800	100	600	85	0,5	1,5	0,2	0,8589	1 x M10	85	0,853
300	360	5900	500	6300	280	0,4	1	0,2	3,299	1 x M12	120	1,71
300	360	5900	280	1500	150	0,5	1,5	0,2	3,454	1 x M12	120	1,77
500	600	4900	680	8800	100	0,5	1	0,2	5,585	1 x M14	190	2,39
500	600	4900	310	1000	85	1	1,5	0,2	5,855	1 x M14	190	2,49

To continue see next page

## Metal Bellows Couplings RINGFEDER® GWB PKA

### Transmissible torque T [Nm]

Size	Ø3	Ø4	Ø5	Ø6	Ø7	Ø8	Ø9	Ø10	Ø11	Ø12	Ø13	Ø14	Ø15	Ø16	Ø17	Ø18	Ø19	Ø20	Ø21	Ø22	Ø24	Ø25	Ø28	Ø30	Ø35	Ø40	Ø45	Ø50	Ø55	Ø60	Ø64	
0,4	0,5	0,5	0,5	0,5	0,5	0,5	-	-	-	-	-	-	-	-	-	-	-	-	-	-	-	-	-	-	-	-	-	-	-	-	-	
0,9	0,5	0,5	0,5	0,5	0,5	0,5	-	-	-	-	-	-	-	-	-	-	-	-	-	-	-	-	-	-	-	-	-	-	-	-	-	
1,5	1,5	1,75	1,75	1,75	1,75	1,75	1,75	1,75	-	-	-	-	-	-	-	-	-	-	-	-	-	-	-	-	-	-	-	-	-	-	-	
2	1,7	2,3	2,4	2,4	2,4	2,4	2,4	2,4	2,4	2,4	2,4	2,4	-	-	-	-	-	-	-	-	-	-	-	-	-	-	-	-	-	-	-	
4,5	-	-	5,5	5,5	5,5	5,5	5,5	5,5	5,5	5,5	5,5	5,5	5,5	5,5	5,5	-	-	-	-	-	-	-	-	-	-	-	-	-	-	-	-	
10	-	-	7	8	9	10,5	12	12	12	12	12	12	12	12	12	12	12	12	12	12	12	12	-	-	-	-	-	-	-	-	-	-
18	-	-	-	-	-	18	20	22	22	22	22	22	22	22	22	22	22	22	22	22	22	22	22	-	-	-	-	-	-	-	-	-
30	-	-	-	-	-	-	-	36	36	36	36	36	36	36	36	36	36	36	36	36	36	36	36	36	36	36	36	-	-	-	-	-
60	-	-	-	-	-	-	-	-	-	75	75	75	75	75	75	75	75	75	75	75	75	75	75	75	75	75	75	-	-	-	-	-
150	-	-	-	-	-	-	-	-	-	-	-	-	180	180	180	180	180	180	180	180	180	180	180	180	180	180	180	-	-	-	-	-
300	-	-	-	-	-	-	-	-	-	-	-	-	-	-	-	-	-	-	-	-	-	-	360	360	360	360	360	360	360	360	360	-
500	-	-	-	-	-	-	-	-	-	-	-	-	-	-	-	-	-	-	-	-	-	-	-	-	600	600	600	600	600	600	600	600

### Explanation

<b>L</b> = Total length	<b>C<sub>1</sub></b> = Guided length in hub bore	<b>C<sub>Tdyn</sub></b> = Dynamic torsional stiffness
<b>d<sub>1min</sub></b> = Min. bore diameter d <sub>1</sub>	<b>D<sub>1</sub></b> = Outer diameter	<b>C<sub>r</sub></b> = Radial spring stiffness
<b>d<sub>1max</sub></b> = Max. bore diameter d <sub>1</sub>	<b>H</b> = Clearance diameter	<b>C<sub>a</sub></b> = Axial spring stiffness
<b>d<sub>2min</sub></b> = Min. bore diameter d <sub>2</sub>	<b>I</b> = Distance between center screw hole and hub end	<b>ΔK<sub>a</sub></b> = Max. permissible axial misalignment
<b>d<sub>2max</sub></b> = Max. bore diameter d <sub>2</sub>	<b>K</b> = Distance shaft axis - clamping screw axis	<b>ΔK<sub>w</sub></b> = Max. permissible angular misalignment
<b>d<sub>1kmin</sub></b> = Min. bore diameter d <sub>1</sub> with keyway acc. to DIN 6885-1	<b>L<sub>6</sub></b> = Length of basic part	<b>ΔK<sub>r</sub></b> = Max. permissible radial misalignment
<b>d<sub>1kmax</sub></b> = Max. bore diameter d <sub>1</sub> with keyway acc. to DIN 6885-1	<b>L<sub>7</sub></b> = Body length until bellow beginning or plug connection	<b>J</b> = Total moment of inertia
<b>d<sub>2kmin</sub></b> = Min. bore diameter d <sub>2</sub> with keyway acc. to DIN 6885-1	<b>V</b> = Preload distance	<b>n<sub>Sc1</sub></b> = Quantity of screws D <sub>G1</sub>
<b>d<sub>2kmax</sub></b> = Max. bore diameter d <sub>2</sub> with keyway acc. to DIN 6885-1	<b>T</b> = Transmissible torque at given T <sub>A</sub>	<b>D<sub>G1</sub></b> = Thread
	<b>n<sub>max</sub></b> = Max. rotation speed	<b>T<sub>A1</sub></b> = Tightened torque of clamping screw D <sub>G1</sub>
		<b>G<sub>w</sub></b> = Weight

### Ordering example

Series/Size	Length	Bore diameter d <sub>1</sub>	Bore diameter d <sub>2</sub>	Position	Further details
PKA 2	43	12	12	D	*

C = Single position

D = Multi position

\* Keyway

Further information on  
**RINGFEDER® GWB PKA**  
 on [www.ringfeder.com](http://www.ringfeder.com)

#### Disclaimer of liability

All technical details and notes are non-binding and cannot be used as a basis for legal claims. The user is obligated to determine whether the represented products meet his requirements. We reserve the right carry out modifications at any time in the interests of technical progress.

# Metal Bellows Couplings

## RINGFEDER® GWB Z5106

Metal bellows coupling with clamping  
in split hub design

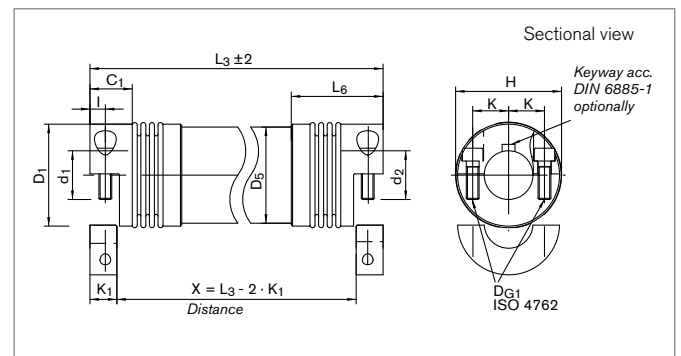
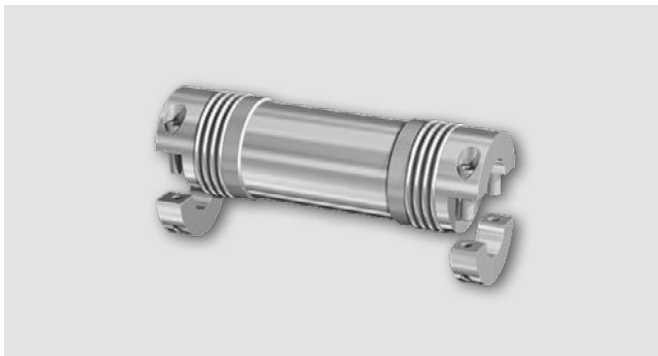

Size	d <sub>1</sub> ;d <sub>2</sub> min-max	d <sub>1k</sub> ;d <sub>2k</sub> min-max	C <sub>1</sub>	D <sub>1</sub>	D <sub>5</sub>	H	I
	mm	mm	mm	mm	mm	mm	mm
18	8 - 25	8 - 22	20	45	40	47,5	6
30	10 - 25	10 - 22	24,5	55	50	56	8
60	12 - 35	12 - 29	29	64	60	66,5	10
150	14 - 40	14 - 36	33	80	80	83	12
200	22 - 44	22 - 38	37,5	90	90	92	13
300	24 - 55	24 - 52	37,5	110	100	110	13
500	35 - 62	35 - 54	41	119	114	122	15

Transmission of the couplings transmissible torque T can not longer be guaranteed for certain with borings < dmin. Types with borings < dmin, however, can be supplied.

Size	K	K <sub>1</sub>	L <sub>3min</sub>	L <sub>3max</sub>	L <sub>6</sub>	T	C <sub>m</sub>	ΔK <sub>w</sub>	D <sub>G1</sub>	T <sub>A1</sub>
	mm	mm	mm	mm	mm	Nm	Nm/rad	degree	mm	Nm
18	17,5	11	134	3000	53	22	3244	1	1 x M5	6
30	20	15	133	3000	52	36	6632	1	1 x M6	12
60	23,5	19	165	3000	64	75	11814	1	1 x M8	30
150	28	21	205	3000	72	180	49929	1	1 x M10	85
200	31	24	218	3000	80	240	75797	1	1 x M12	100
300	39	24	227	3000	83	360	91158	1	1 x M12	120
500	43	27,5	251	3000	90	600	203202	1	1 x M14	190

To continue see next page

## Metal Bellows Couplings RINGFEDER® GWB Z5106

### Transmissible torque T [Nm]

Size	Ø8	Ø9	Ø10	Ø11	Ø12	Ø14	Ø15	Ø18	Ø20	Ø22	Ø24	Ø25	Ø28	Ø30	Ø35	Ø40	Ø45	Ø50	Ø55	Ø60	Ø64
18	13,6	15,3	17	18,7	20,4	22	22	22	22	22	22	22	---	---	---	---	---	---	---	---	---
30	---	---	28	30	33	36	36	36	36	36	36	36	36	36	---	---	---	---	---	---	---
60	---	---	---	---	62	73	75	75	75	75	75	75	75	75	75	---	---	---	---	---	---
150	---	---	---	---	---	167	180	180	180	180	180	180	180	180	180	180	---	---	---	---	---
200	---	---	---	---	---	---	---	---	---	240	240	240	240	240	240	240	240	---	---	---	---
300	---	---	---	---	---	---	---	---	---	---	342	360	360	360	360	360	360	360	360	360	---
500	---	---	---	---	---	---	---	---	---	---	---	---	---	---	600	600	600	600	600	600	600

### Explanation

<b>d<sub>1</sub>;d<sub>2min</sub></b> = Min. bore diameter d <sub>1</sub> /d <sub>2</sub>	<b>I</b> = Distance between center screw hole and hub end	<b>C<sub>m</sub></b> = Torsional stiffness of extension tube per meter
<b>d<sub>1</sub>;d<sub>2max</sub></b> = Max. bore diameter d <sub>1</sub> /d <sub>2</sub>	<b>K</b> = Distance shaft axis - clamping screw axis	<b>ΔK<sub>w</sub></b> = Max. permissible angular misalignment
<b>d<sub>1k</sub>;d<sub>2kmin</sub></b> = Min. bore diameter d <sub>1</sub> /d <sub>2</sub> with keyway acc. to DIN 6885-1	<b>K<sub>1</sub></b> = Clamping length	<b>n<sub>Sc1</sub></b> = Quantity of screws D <sub>G1</sub>
<b>d<sub>1k</sub>;d<sub>2kmax</sub></b> = Max. bore diameter d <sub>1</sub> /d <sub>2</sub> with keyway acc. to DIN 6885-1	<b>L<sub>3min</sub></b> = Min. length of line shaft	<b>D<sub>G1</sub></b> = Thread
<b>C<sub>1</sub></b> = Guided length in hub bore	<b>L<sub>3max</sub></b> = Max. length of line shaft	<b>T<sub>A1</sub></b> = Tightened torque of clamping screw D <sub>G1</sub>
<b>D<sub>1</sub></b> = Outer diameter	<b>L<sub>6</sub></b> = Length of basic part	
<b>D<sub>5</sub></b> = Tube diameter	<b>T</b> = Transmissible torque at given T <sub>A</sub>	
<b>H</b> = Clearance diameter		

### Ordering example

Series/Size	Bore diameter d <sub>1</sub>	Bore diameter d <sub>2</sub>	Length of Line Shaft L <sub>3</sub>	Further details
GWB Z5106-18	8	10	1000	*

\* Keyway or stainless steel

Further information on  
**RINGFEDER® GWB Z5106**  
 on [www.ringfeder.com](http://www.ringfeder.com)

#### Disclaimer of liability

All technical details and notes are non-binding and cannot be used as a basis for legal claims. The user is obligated to determine whether the represented products meet his requirements. We reserve the right carry out modifications at any time in the interests of technical progress.



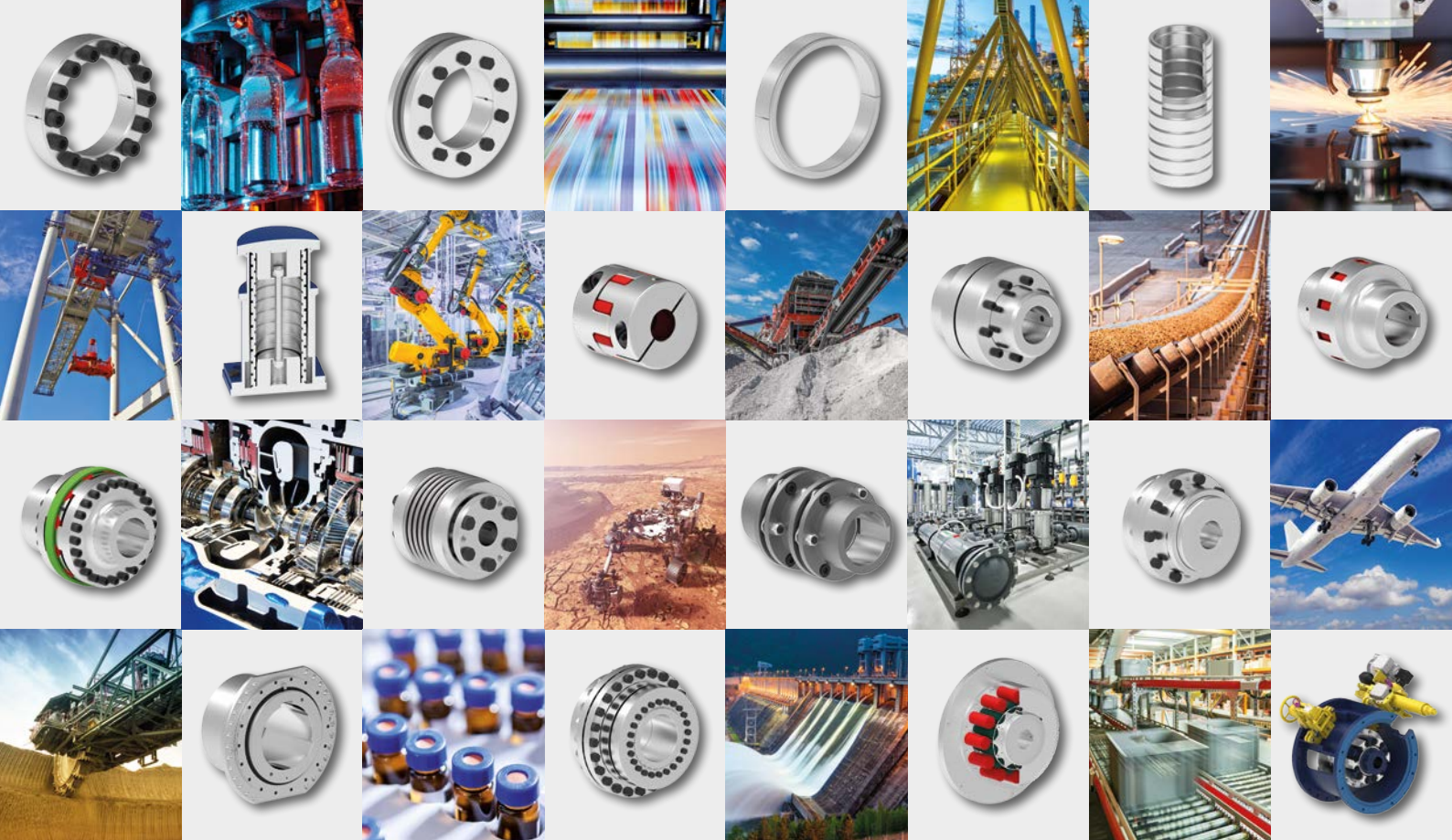

**RINGFEDER POWER TRANSMISSION GMBH**

Werner-Heisenberg-Straße 18, 64823 Groß-Umstadt, Germany · Phone: +49 6078 9385-0 · Fax: +49 6078 9385-100  
E-Mail: sales.international@ringfeder.com

**RINGFEDER POWER TRANSMISSION SP. Z O. O.**

Ul. Szyby Rycerskie 6, 41-909 Bytom, Poland · Phone: +48 32 301 53 00 · Fax: +48 32 722 44 44 · E-Mail: sales.poland@ringfeder.com

**RINGFEDER POWER TRANSMISSION USA CORP.**

291 Boston Turnpike, Bolton, CT 06043, USA · Toll Free: +1 888 746-4333 · Phone: +1 201 666-3320 · Fax: +1 860 646-2645  
E-Mail: sales.usa@ringfeder.com

**CARLYLE JOHNSON MACHINE COMPANY, LLC.**

291 Boston Turnpike, Bolton, CT 06043, USA · Phone: +1 860 643-1531 · Fax: +1 860 646-2645 · E-Mail: info@cjmco.com

**HENFEL INDÚSTRIA METALÚRGICA LTDA.**

Av. Maj. Hilário Tavares Pinheiro 3447, Pq. Ind. Carlos Tonanni, CEP 14871-300, Jaboticabal, SP, Brazil · Phone: +55 (16) 3209-3422  
E-Mail: vendas@henfel.com.br

**RINGFEDER POWER TRANSMISSION INDIA PVT. LTD.**

Plot No. 4, Door No. 220, Mount Poonamallee Road, Kattupakkam, Chennai, 600 056, India · Phone: +91 44 2679-1411  
Fax: +91 44 2679-1422 · E-Mail: sales.india@ringfeder.com

**KUNSHAN RINGFEDER POWER TRANSMISSION CO. LTD.**

No. 406 Jiande Road, Zhangpu 215321, Kunshan, Jiangsu Province, China · Phone: +86 512 5745-3960 · Fax: +86 512 5745-3961  
E-Mail: sales.china@ringfeder.com

Partner for Performance  
[www.ringfeder.com](http://www.ringfeder.com)

