

Advanced Linear Systems from WITTENSTEIN alpha –
outstanding performance in the Advanced Segment

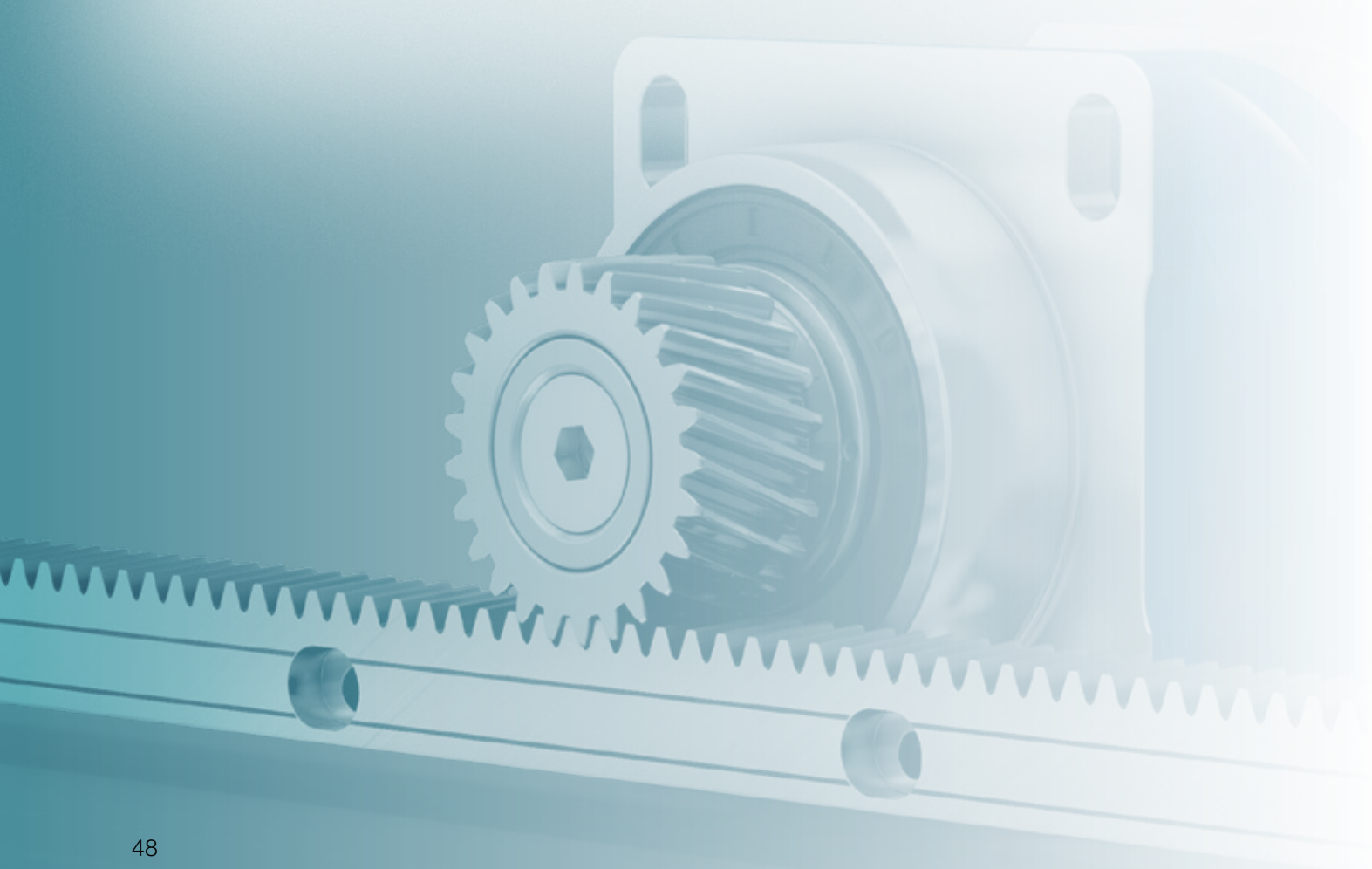

Advanced Linear Systems – the perfect solution for linear feed drives for almost every automation, wood working and machine tool application

The Advanced Linear System with **SP+** and associated right-angle versions is used predominantly as a single drive within a range of up to 12,500 N/drive.

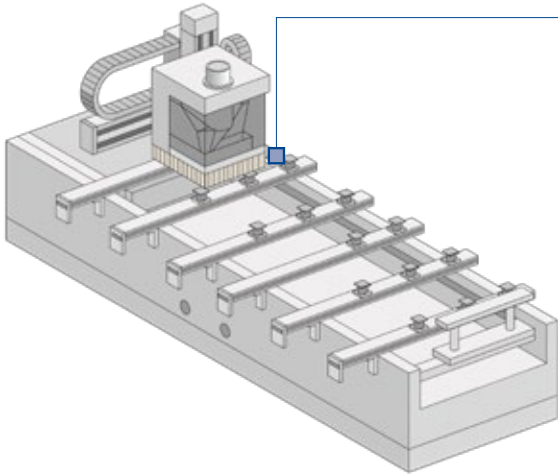

Wood working machine

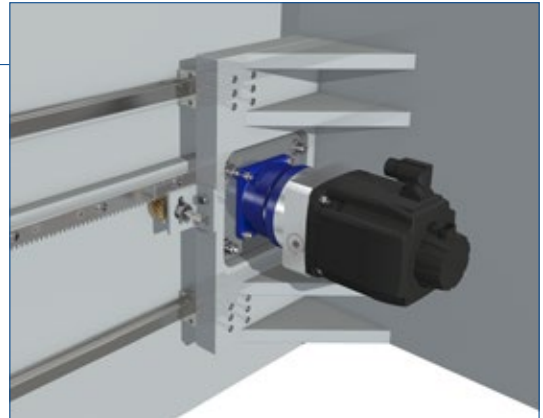

The Advanced Linear System with **TP+** or **TP+ HIGH TORQUE** and associated right-angle versions is used as a single drive or master/slave drive within a range of up to 21,000 N/drive.

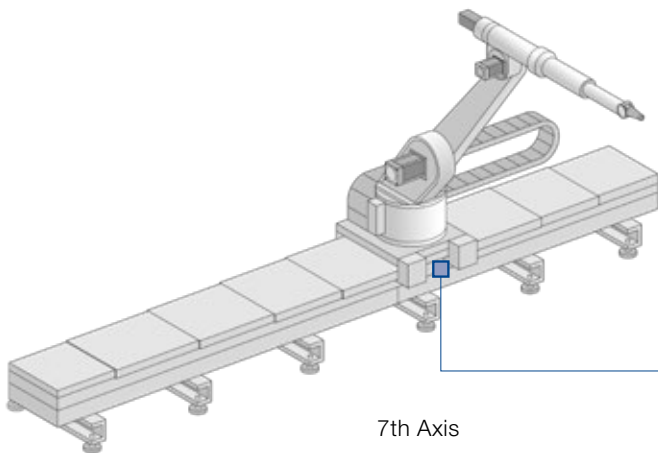

7th Axis

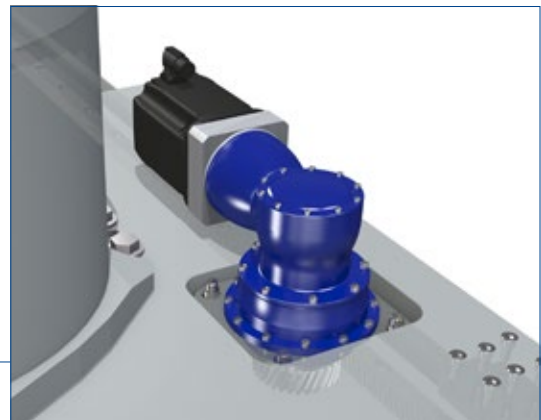

Outstanding performance in the Advanced Segment

These systems are adapted to applications with average to high demands in terms of smooth running, positioning accuracy and feed force. Different gearbox versions and options such as HIGH TORQUE or HIGH SPEED can be selected to choose the best system for the application.

Your benefits

- Perfectly adapted linear systems available with planetary, right-angle and worm gearboxes or as an servo actuator
- Optionally with INIRA®
- Large individual configuration range due to numerous pinion/gearbox combinations

		Advanced Linear System	Max. feed force [N]	Max. feed speed [m/min]
with SP+		ALS 2	2230	250
		ALS 3	3250	300
		ALS 6	6040	281
		ALS 8	8600	333
		ALS 12	12500	400
with TP+	MF	ALS 1	1370	325
		ALS 2	2500	412
		ALS 3	3600	367
		ALS 12	11800	438
		ALS 20	19700	570
	MA	ALS 4	4200	45
		ALS 11	10900	57
		ALS 21	21000	68

Feed force and feed speed dependent on ratio



SP+



TP+ MF



TP+ MA

Quick system selection

- SP+
- TP+ MF
- TP+ MA

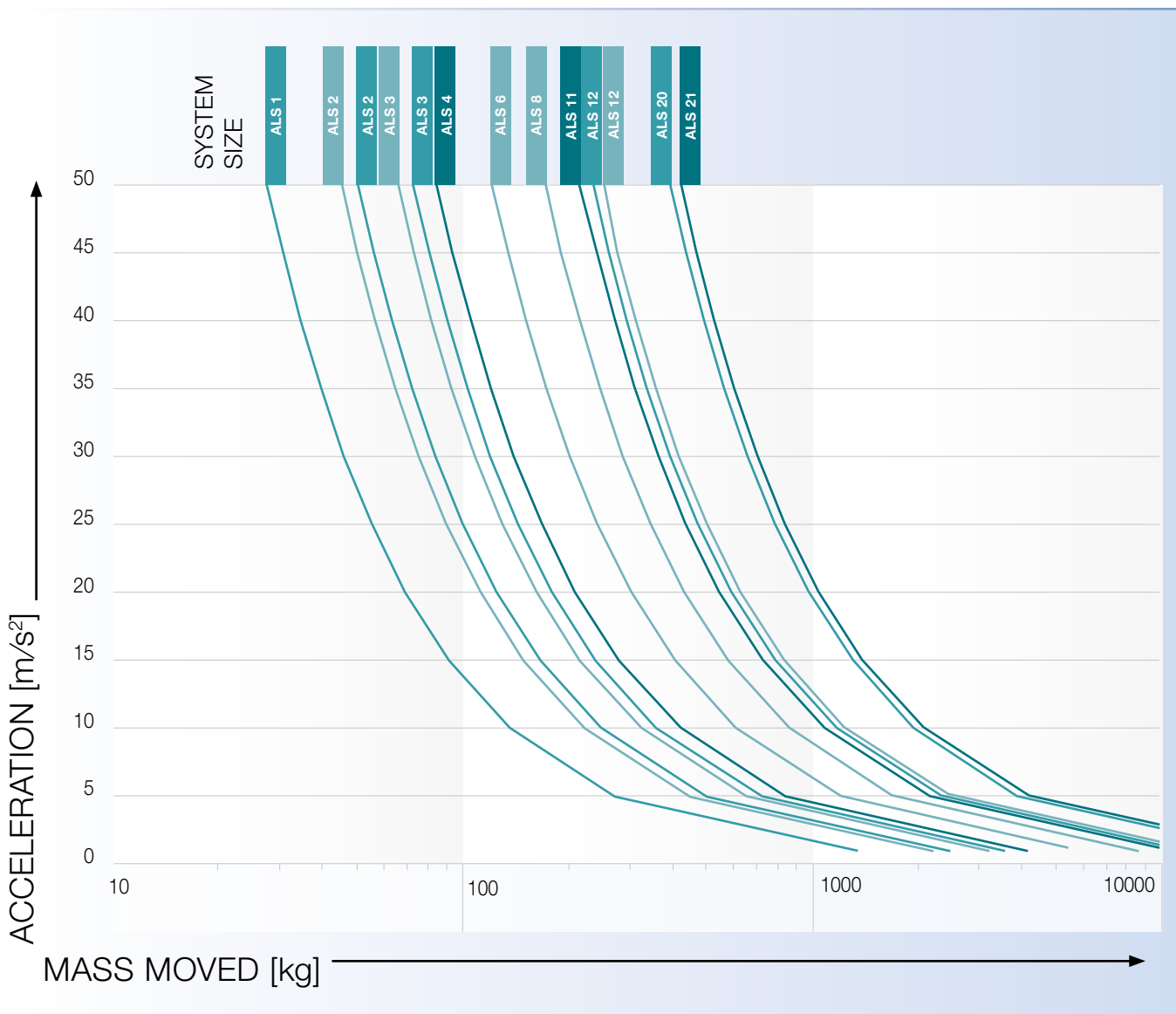

Advanced Linear Systems

Advanced Linear Systems overview

Our preferred linear systems are always comprised of the perfect combination of gearbox, pinion, rack and lubrication system. The systems are optimized to achieve the required feed force, feed speed, rigidity and degree of utilization of the individual components. Depending on your individual requirements, you have the option to further configure products via the ordering code. For a detailed dimensioning and configuration of the products we recommend to use cymex® 5.

System	Gearbox	Pinion	Rack*
ALS 2	SP+ 060R	RMS 200-323-15L1-016	ZST 200-332-1000-R1
ALS 3	SP+ 075R	RMS 200-323-18L1-022	ZST 200-332-1000-R1
ALS 6	SP+ 100R	RMS 200-323-23L1-032	ZST 200-333-1000-R1
ALS 8	SP+ 140R	RMS 300-323-20L1-040	ZST 300-332-1000-R1
ALS 12	SP+ 180	RMS 400-323-20L1-055	ZST 400-332-1000-R1
ALS 1	TP+ 004 MF	RMF 200-443-26L1-031-8xM5	ZST 200-332-1000-R1
ALS 2	TP+ 010 MF	RMF 200-443-33L1-050-8xM6	ZST 200-332-1000-R1
ALS 3	TP+ 025 MF	RMF 200-443-40L1-063-12xM6	ZST 200-332-1000-R1
ALS 12	TP+ 050 MF	RMF 300-443-35L1-080-12xM8	ZST 300-333-1000-R1
ALS 20	TP+ 110 MF	RMF 400-443-38L1-125-12xM10	ZST 400-334-1000-R11
ALS 4	TP+ 025 MA	RMW 200-444-20L1-037	ZST 200-332-1000-R1
ALS 11	TP+ 050 MA	RMW 300-444-20L1-055	ZST 300-333-1000-R1
ALS 21	TP+ 110 MA	RMW 400-444-20L1-073	ZST 400-334-1000-R11

* Other length options available

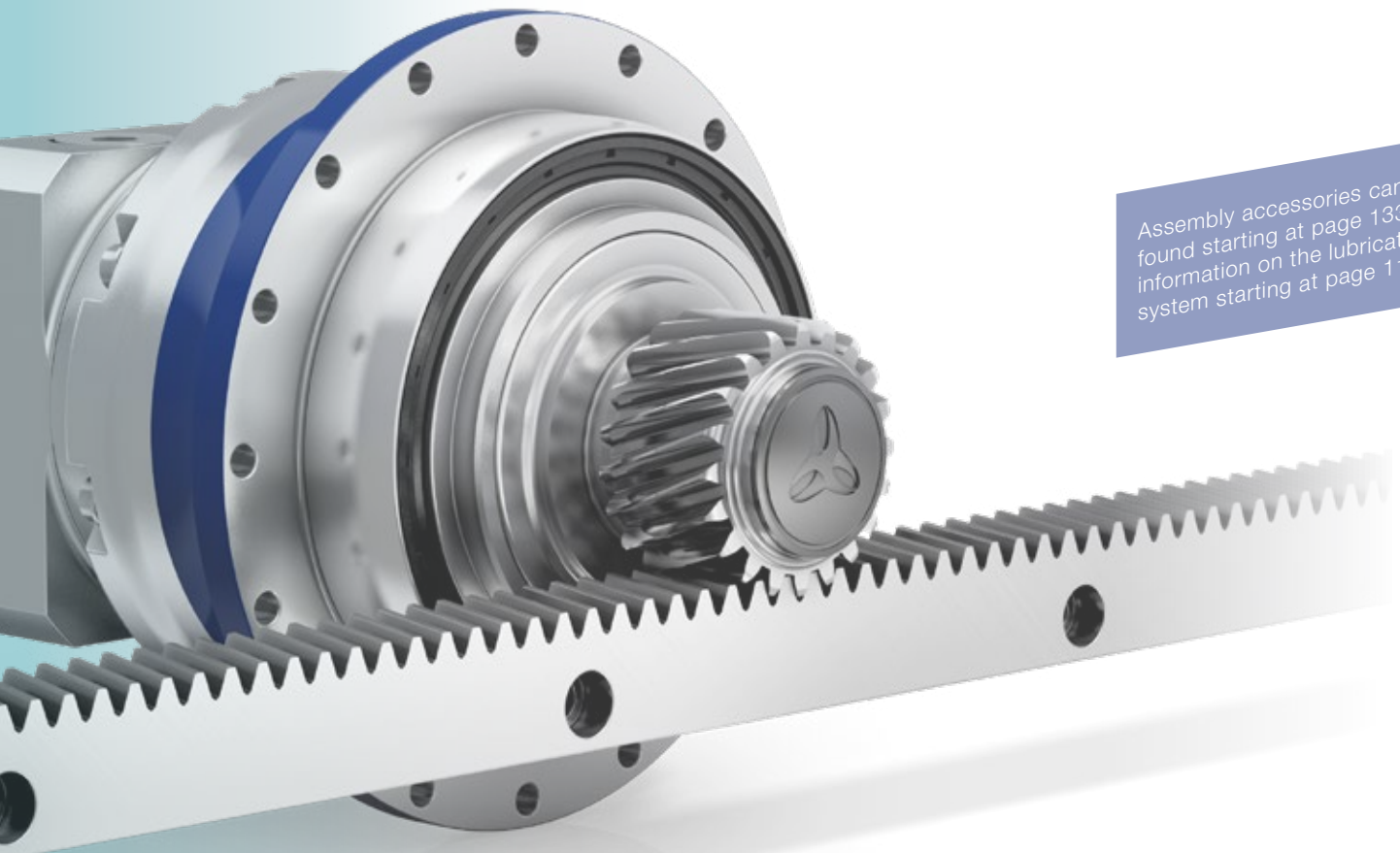

Assembly accessories can be found starting at page 133 and information on the lubrication system starting at page 118

Ordering code

Gearbox*

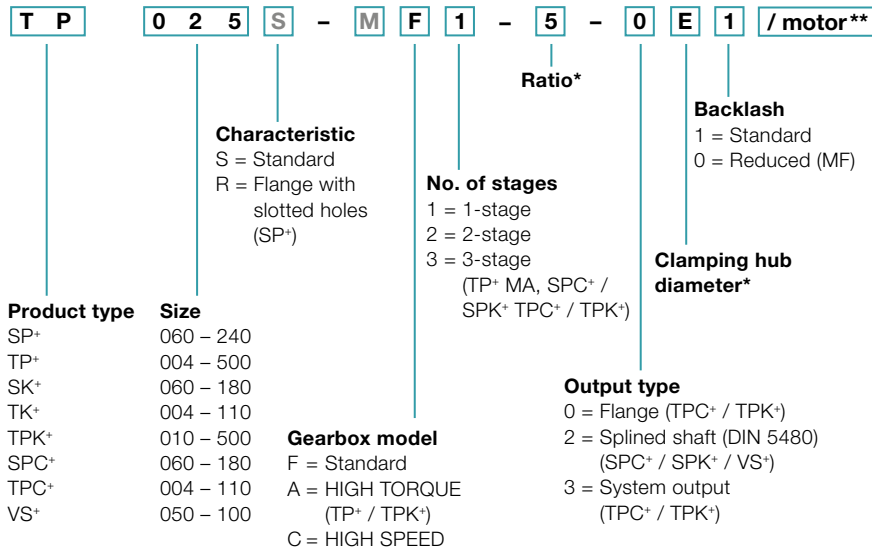

M Components with a gray font cannot be selected

* Further information on the gearboxes can be obtained from the respective catalogs, online at www.wittenstein-alpha.com or on request

** Full motor designation only required for determining gearbox mounting parts

Rack

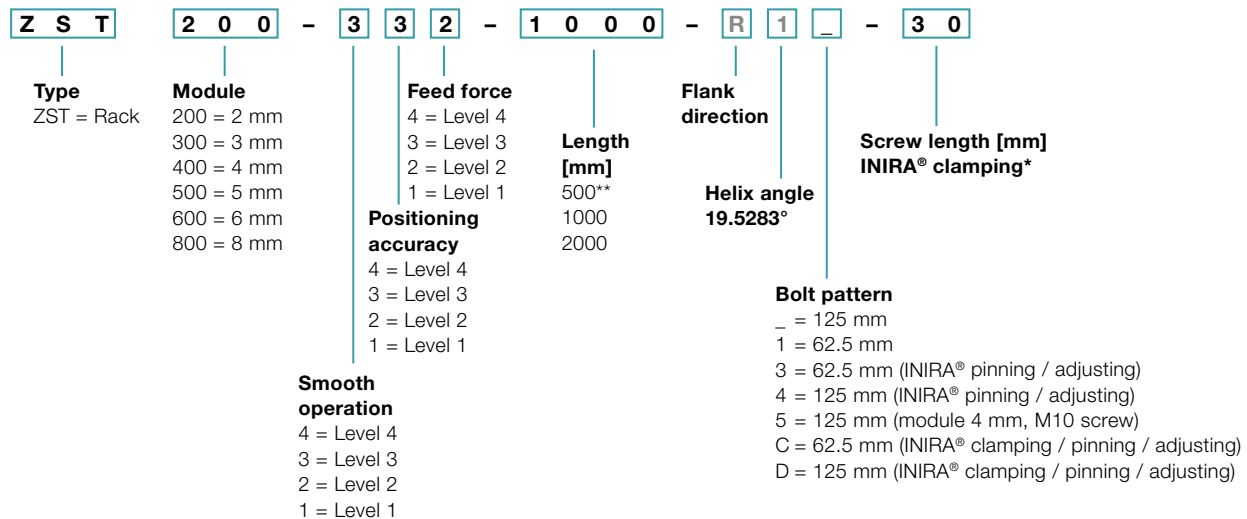

* Please refer to page 134 for an overview of available screw lengths

** Module 4, 493 mm

Pinion

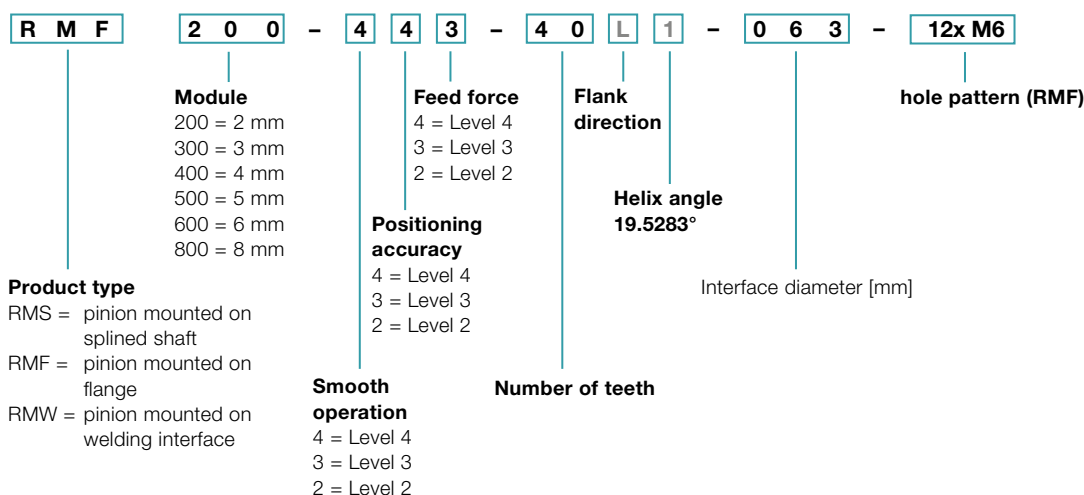

Advanced Linear System ALS 2 with SP+

Planetary gearbox SP+ 060R MF with rack module 2 and pinion RMS module 2

System	Max. feed force ¹⁾ F_{zT}		2230 N	
	Max. feed speed ²⁾ v_{max}		250 m/min	53 m/min
Gearbox	No. of stages		1	2
	Ratios i		3 / 4 / 5 / 7 / 8 / 10	16 / 20 / 25 / 28 / 32 / 35 / 40 / 50 / 64 / 70 / 100
	Clamping hub diameter		11 / 14 / 19 mm	11 / 14 mm
	Designation		SP 060R-MF1-_-_-_-2_-_-	SP 060R-MF2-_-_-_-2_-_-
Pinion	Module m		2 mm	
	Number of teeth z		15	
	Pitch circle diameter d		31.831 mm	
	Profile correction factor x		0.5	
	Helix angle β		-19.5283° (left-handed)	
	Designation		RMS 200-323-15L1-016	
Rack	Module m		2 mm	
	Length L (options)		1000 mm (2000 mm; 500 mm)	
	Helix angle β		19.5283° (right-handed)	
	Designation		ZST 200-332-1000-R1; optionally with INIRA®	
Lubrication system ³⁾	Set consisting of lubrication pinion and axis for	Rack	LMT 200-PU -18L1-024-1	
		Pinion	LMT 200-PU -18R1-024-1	
	Lubricator	125 cm ³	LUC+125-0511-02	
		400 cm ³	LUC+400-0511-02	
	Lubricant		WITTENSTEIN alpha G11	

¹⁾ Maximum feed force depending on ratio and number of stages

²⁾ Calculation with lowest ratio and maximum input speed

³⁾ Impulse-controlled basic version with one output and 2 m hose. See page 118 for further information on the lubrication system. Application-specific dimensioning with cymex® – www.wittenstein-cymex.com

Alternative system solutions

Pinion			Axis distance	SP+ 060R	PBG 1	SK+ 060S	SPC+ 060S	Rack*
Designation	d [mm]	x []	A [mm]	F_{zT} [N]	F_{zT} [N]	F_{zT} [N]	F_{zT} [N]	Designation
RMK 200-222-18L1-016-019	38.197	0.4	41.899	2210	2210	1870	2210	ZST 200-332-1000-R1; optionally with INIRA®
RMS 200-323-15L1-016	31.831	0.5	38.916	2230	2230	2180	2230	ZST 200-332-1000-R1; optionally with INIRA®
RMS 200-323-16L1-016	33.953	0.5	39.977	2230	2230	2080	2230	ZST 200-332-1000-R1; optionally with INIRA®
RMS 200-323-18L1-016	38.197	0.4	41.899	2210	2210	1870	2210	ZST 200-332-1000-R1; optionally with INIRA®

d = Pitch circle diameter

x = Addendum modification coefficient

A = Distance between pinion axle and rear surface of rack

F_{zT} = Maximum feed force depending on ratio and number of stages

Application-specific dimensioning with cymex® – www.wittenstein-cymex.com

* Other length options available

1-stage

greater than 11 (B) up to 14⁴⁾ (C) clamping hub diameters

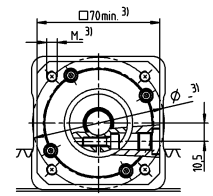
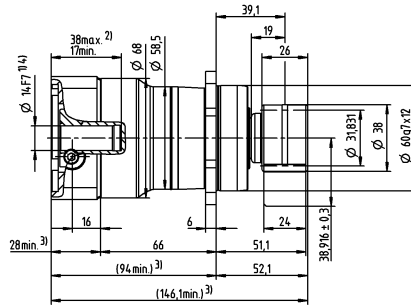
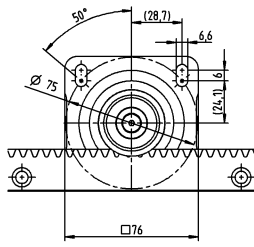

up to 19⁴⁾ (E) clamping hub diameters

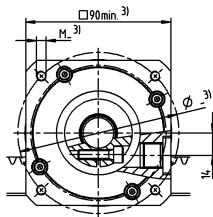
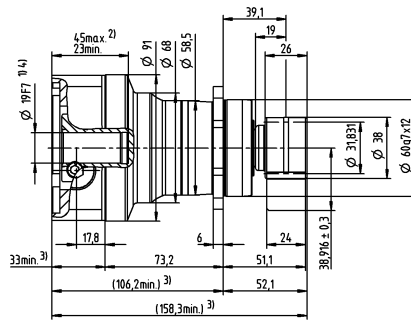
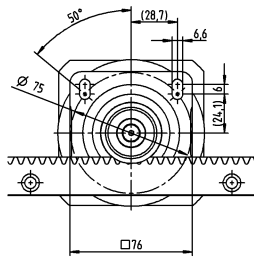

2-stage

up to 11⁴⁾ (B) clamping hub diameters

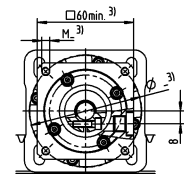
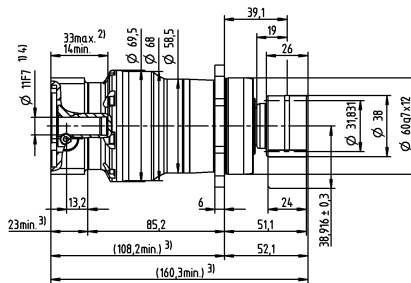
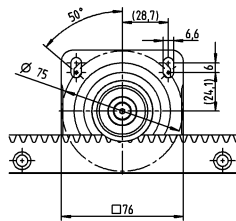

up to 14⁴⁾ (C) clamping hub diameters

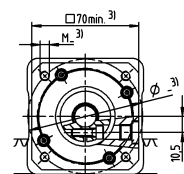
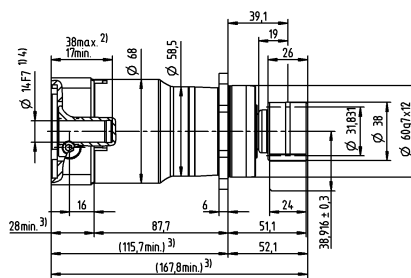
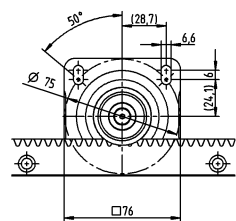

Motor shaft diameter [mm]

Non-tolerated dimensions are nominal dimensions
Detailed rack dimensions starting on page 161

- ¹⁾ Check motor shaft fit
- ²⁾ Min./Max. permissible motor shaft length. Longer motor shafts are possible, please contact alpha.
- ³⁾ The dimensions depend on the motor
- ⁴⁾ Smaller motor shaft diameter is compensated by a bushing with a minimum thickness of 1 mm

Advanced Linear System ALS 3 with SP+

Planetary gearbox SP+ 075R MF with rack module 2 and pinion RMS module 2

System	Max. feed force ¹⁾ F_{zT}		3250 N	
	Max. feed speed ²⁾ v_{max}		300 m/min	64 m/min
Gearbox	No. of stages		1	2
	Ratios i		3 / 4 / 5 / 7 / 8 / 10	16 / 20 / 25 / 28 / 32 / 35 / 40 / 50 / 64 / 70 / 100
	Clamping hub diameter		14 / 19 / 24 mm	11 / 14 / 19 mm
	Designation		SP 075R-MF1-_-_-_-2_-_-	SP 075R-MF2-_-_-_-2_-_-
Pinion	Module m		2 mm	
	Number of teeth z		18	
	Pitch circle diameter d		38.197 mm	
	Profile correction factor x		0.4	
	Helix angle β		-19.5283° (left-handed)	
	Designation		RMS 200-323-18L1-022	
Rack	Module m		2 mm	
	Length L (options)		1000 mm (2000 mm; 500 mm)	
	Helix angle β		19.5283° (right-handed)	
	Designation		ZST 200-332-1000-R1; optionally with INIRA®	
Lubrication system ³⁾	Set consisting of lubrication pinion and axis for	Rack	LMT 200-PU -18L1-024-1	
		Pinion	LMT 200-PU -18R1-024-1	
	Lubricator	125 cm ³	LUC+125-0511-02	
		400 cm ³	LUC+400-0511-02	
	Lubricant		WITTENSTEIN alpha G11	

¹⁾ Maximum feed force depending on ratio and number of stages

²⁾ Calculation with lowest ratio and maximum input speed

³⁾ Impulse-controlled basic version with one output and 2 m hose. See page 118 for further information on the lubrication system.

Application-specific dimensioning with cymex® – www.wittenstein-cymex.com

Alternative system solutions

Pinion			Axis distance	SP+ 075R	PBG 2	SK+ 075S	SPC+ 075S	SPK+ 075S	Rack*
Designation	d [mm]	x []	A [mm]	F_{zT} [N]	F_{zT} [N]	F_{zT} [N]	F_{zT} [N]	F_{zT} [N]	Designation
RMK 200-222-22L1-022-020	46.686	0.2	45.743	3230	3230	3380	3230	3250	ZST 200-332-1000-R1; optionally with INIRA®
RMS 200-323-18L1-022	38.197	0.4	41.899	3250	3250	3390	3250	3280	ZST 200-332-1000-R1; optionally with INIRA®
RMS 200-323-20L1-022	42.441	0.4	44.021	3240	3240	3400	3250	3280	ZST 200-332-1000-R1; optionally with INIRA®
RMS 200-323-22L1-022	46.686	0.4	46.143	3230	3230	3380	3230	3250	ZST 200-332-1000-R1; optionally with INIRA®

d = Pitch circle diameter

x = Addendum modification coefficient

A = Distance between pinion axle and rear surface of rack

F_{zT} = Maximum feed force depending on ratio and number of stages

Application-specific dimensioning with cymex® – www.wittenstein-cymex.com

* Other length options available

1-stage

greater than 14 (C) up to 19⁴⁾ (E) clamping hub diameters

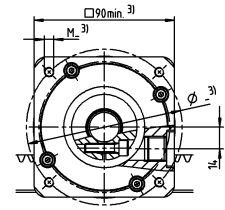
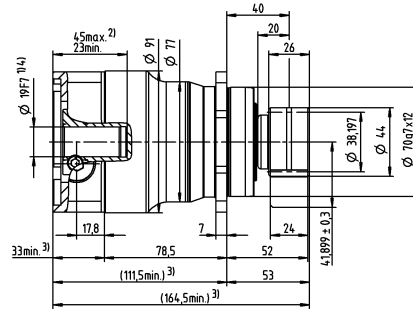
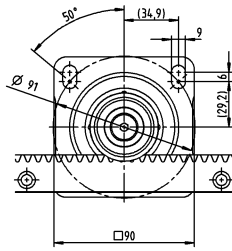

up to 24⁴⁾ (G) clamping hub diameters

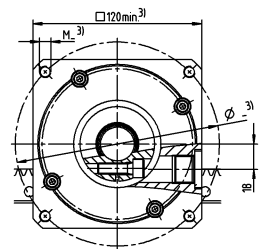
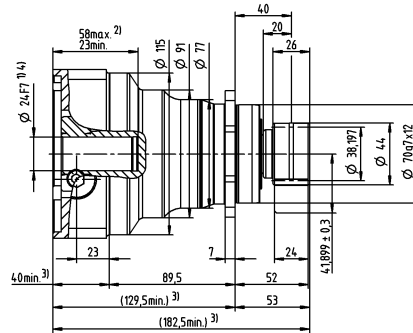
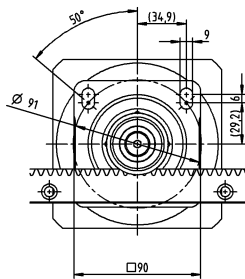

2-stage

greater than 11 (B) up to 14⁴⁾ (C) clamping hub diameters

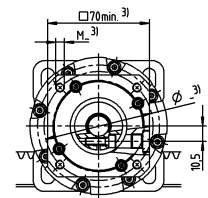
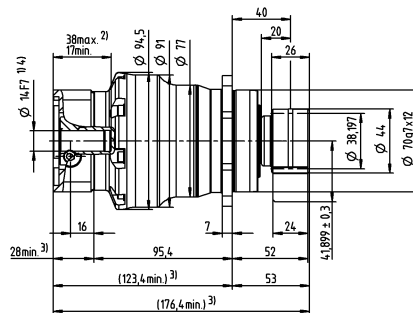
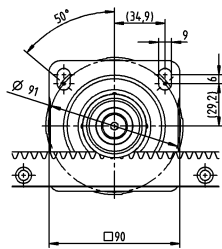

up to 19⁴⁾ (E) clamping hub diameters

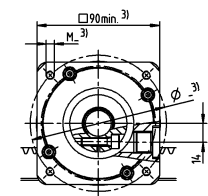
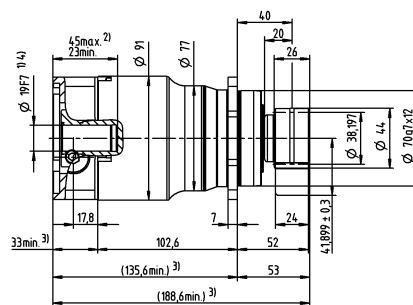
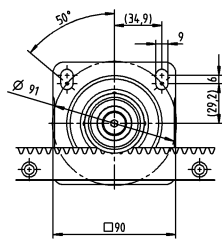

Motor shaft diameter [mm]

Non-tolerated dimensions are nominal dimensions
Detailed rack dimensions starting on page 161

¹⁾ Check motor shaft fit

²⁾ Min./Max. permissible motor shaft length. Longer motor shafts are possible, please contact alpha.

³⁾ The dimensions depend on the motor

⁴⁾ Smaller motor shaft diameter is compensated by a bushing with a minimum thickness of 1 mm

Advanced Linear System ALS 6 with SP+

Planetary gearbox SP+ 100R MF with rack module 2 and pinion RMS module 2

System	Max. feed force ¹⁾ F_{zT}		6040 N	
	Max. feed speed ²⁾ v_{max}		281 m/min	62 m/min
Gearbox	No. of stages		1	2
	Ratios i		3 / 4 / 5 / 7 / 8 / 10	16 / 20 / 25 / 28 / 32 / 35 / 40 / 50 / 64 / 70 / 100
	Clamping hub diameter		19 / 24 / 28 / 38 mm	14 / 19 / 24 / 28 mm
	Designation		SP 100R-MF1-_-_-_-2_-_-	SP 100R-MF2-_-_-_-2_-_-
Pinion	Module m		2 mm	
	Number of teeth z		23	
	Pitch circle diameter d		48.808 mm	
	Profile correction factor x		0.4	
	Helix angle β		-19.5283° (left-handed)	
	Designation		RMS 200-323-23L1-032	
Rack	Module m		2 mm	
	Length L (options)		1000 mm (2000 mm; 500 mm)	
	Helix angle β		19.5283° (right-handed)	
	Designation		ZST 200-332-1000-R1; optionally with INIRA®	
Lubrication system ³⁾	Set consisting of lubrication pinion and axis for	Rack	LMT 200-PU -18L1-024-1	
		Pinion	LMT 200-PU -18R1-024-1	
	Lubricator	125 cm ³	LUC+125-0511-02	
		400 cm ³	LUC+400-0511-02	
	Lubricant		WITTENSTEIN alpha G11	

¹⁾ Maximum feed force depending on ratio and number of stages

²⁾ Calculation with lowest ratio and maximum input speed

³⁾ Impulse-controlled basic version with one output and 2 m hose. See page 118 for further information on the lubrication system. Application-specific dimensioning with cymex® – www.wittenstein-cymex.com

Alternative system solutions

Pinion			Axis distance	SP+ 100R	PBG 3	SK+ 100S	SPC+ 100S	SPK+ 100S	Rack*
Designation	d [mm]	x []	A [mm]	F_{zT} [N]	F_{zT} [N]	F_{zT} [N]	F_{zT} [N]	F_{zT} [N]	Designation
RMK 200-222-26L1-032-021	55.174	0	49.587	6000	6000	5350	6000	6000	ZST 200-332-1000-R1; optionally with INIRA®
RMS 200-323-23L1-032	48.808	0.4	47.204	6040	6040	5350	6040	6040	ZST 200-332-1000-R1; optionally with INIRA®
RMS 200-323-25L1-032	53.052	0.4	49.326	6020	6020	5350	6020	6020	ZST 200-332-1000-R1; optionally with INIRA®
RMS 200-323-27L1-032	57.296	0.3	51.248	6000	6000	5350	6000	6000	ZST 200-332-1000-R1; optionally with INIRA®

d = Pitch circle diameter

x = Addendum modification coefficient

A = Distance between pinion axle and rear surface of rack

F_{zT} = Maximum feed force depending on ratio and number of stages

Application-specific dimensioning with cymex® – www.wittenstein-cymex.com

* Other length options available

1-stage

greater than 19 (E) up to 24/28⁴⁾ (G/H) clamping hub diameters

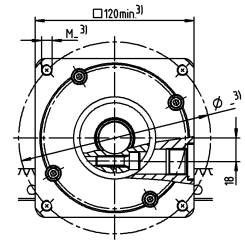
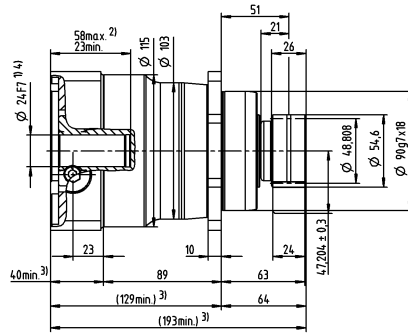
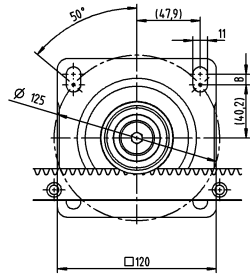

up to 38⁴⁾ (K) clamping hub diameters

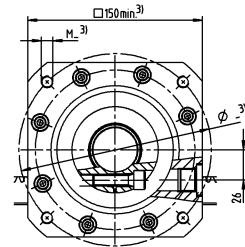
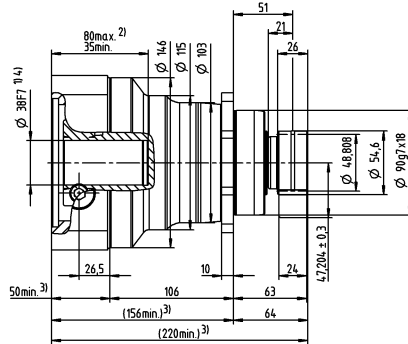
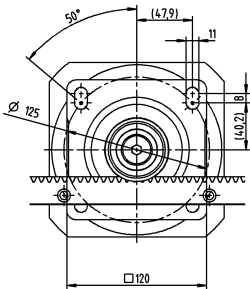

2-stage

greater than 14 (C) up to 19⁴⁾ (E) clamping hub diameters

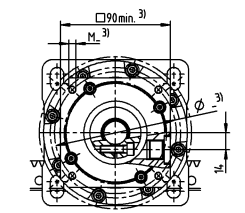
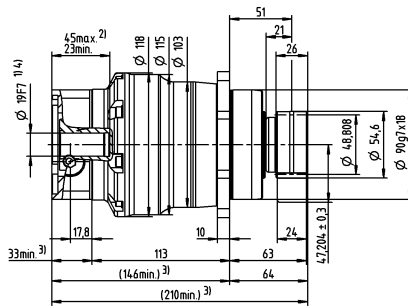
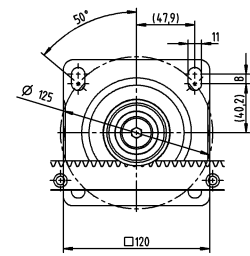

up to 24/28⁴⁾ (G/H) clamping hub diameters

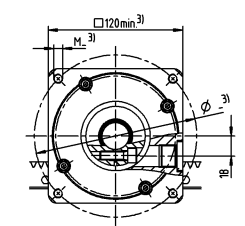
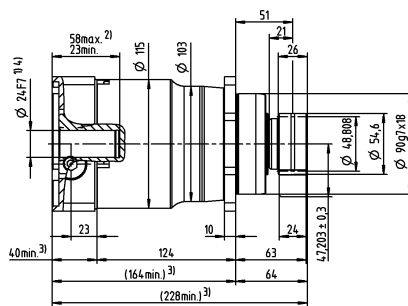
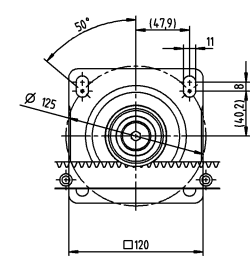

Motor shaft diameter [mm]

Non-tolerated dimensions are nominal dimensions
Detailed rack dimensions starting on page 161

¹⁾ Check motor shaft fit

²⁾ Min./Max. permissible motor shaft length. Longer motor shafts are possible, please contact alpha.

³⁾ The dimensions depend on the motor

⁴⁾ Smaller motor shaft diameter is compensated by a bushing with a minimum thickness of 1 mm

Advanced Linear System ALS 8 with SP+

Planetary gearbox SP+ 140R MF with rack module 3 and pinion RMS module 3

System	Max. feed force ¹⁾ F_{zT}	8600 N	
	Max. feed speed ²⁾ v_{max}	333 m/min	75 m/min
Gearbox	No. of stages	1	2
	Ratios i	3 / 4 / 5 / 7 / 8 / 10	16 / 20 / 25 / 28 / 32 / 35 / 40 / 50 / 64 / 70 / 100
	Clamping hub diameter	24 / 32 / 38 / 48 mm	19 / 24 / 38 mm
	Designation	SP 140R-MF1-_-_-_-2_-_-	SP 140R-MF2-_-_-_-2_-_-
Pinion	Module m	3 mm	
	Number of teeth z	20	
	Pitch circle diameter d	63.662 mm	
	Profile correction factor x	0.4	
	Helix angle β	-19.5283° (left-handed)	
	Designation	RMS 300-323-20L1-040	
Rack	Module m	3 mm	
	Length L (options)	1000 mm (2000 mm; 500 mm)	
	Helix angle β	19.5283° (right-handed)	
	Designation	ZST 300-332-1000-R1; optionally with INIRA®	
Lubrication system ³⁾	Set consisting of lubrication pinion and axis for	Rack	LMT 300-PU -18L1-030-1
		Pinion	LMT 300-PU -18R1-030-1
	Lubricator	125 cm ³	LUC+125-0511-02
		400 cm ³	LUC+400-0511-02
	Lubricant	WITTENSTEIN alpha G11	

¹⁾ Maximum feed force depending on ratio and number of stages

²⁾ Calculation with lowest ratio and maximum input speed

³⁾ Impulse-controlled basic version with one output and 2 m hose. See page 118 for further information on the lubrication system.

Application-specific dimensioning with cymex® – www.wittenstein-cymex.com

Alternative system solutions

Pinion			Axis distance	SP+ 140R	SK+ 140S	SPC+ 140S	SPK+ 140S	Rack*
Designation	d [mm]	x []	A [mm]	F_{zT} [N]	F_{zT} [N]	F_{zT} [N]	F_{zT} [N]	Designation
RMK 300-222-24L1-040-035	76.394	0	64.197	8550	8340	8550	8520	ZST 300-332-1000-R1; optionally with INIRA®
RMS 300-323-20L1-040	63.662	0.4	59.031	8600	8380	8600	8600	ZST 300-332-1000-R1; optionally with INIRA®
RMS 300-323-22L1-040	70.028	0.4	62.214	8590	8360	8590	8540	ZST 300-332-1000-R1; optionally with INIRA®
RMS 300-323-24L1-040	76.394	0.4	65.397	8550	8340	8550	8520	ZST 300-332-1000-R1; optionally with INIRA®

d = Pitch circle diameter

x = Addendum modification coefficient

A = Distance between pinion axle and rear surface of rack

F_{zT} = Maximum feed force depending on ratio and number of stages

Application-specific dimensioning with cymex® – www.wittenstein-cymex.com

* Other length options available

1-stage

greater than 24 (G)
up to 32/38⁴⁾ (I/K)
clamping hub
diameters

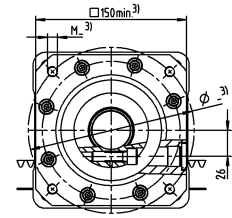
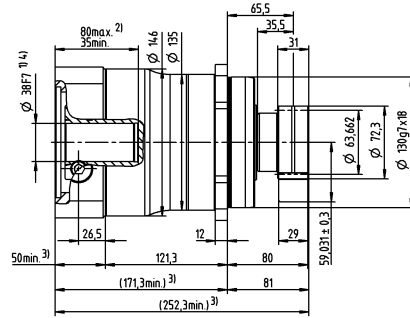
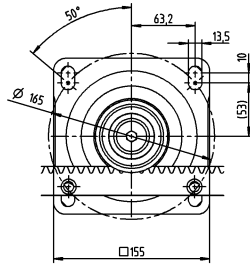

up to 48⁴⁾ (M)
clamping hub
diameters

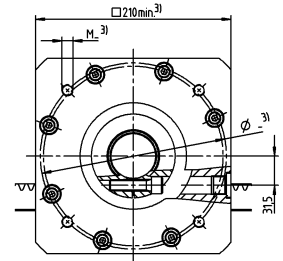
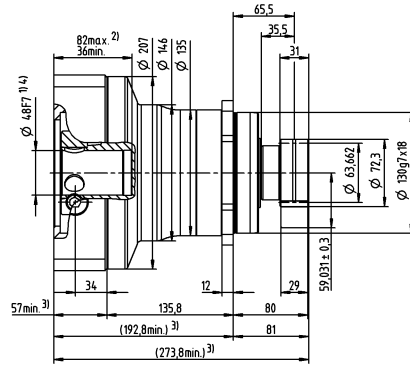
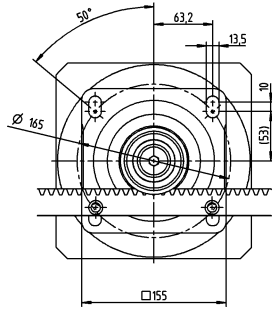

2-stage

greater than 19 (E)
up to 24⁴⁾ (G)
clamping hub
diameters

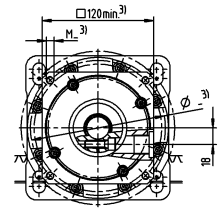
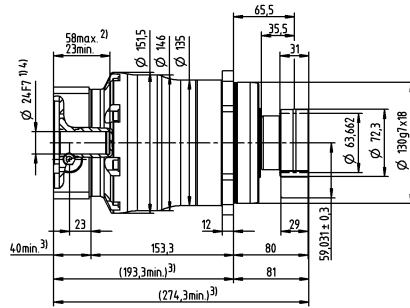
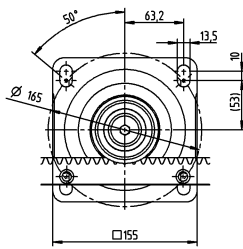

up to 38⁴⁾ (K)
clamping hub
diameters

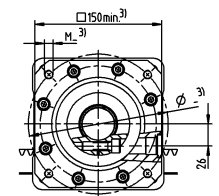
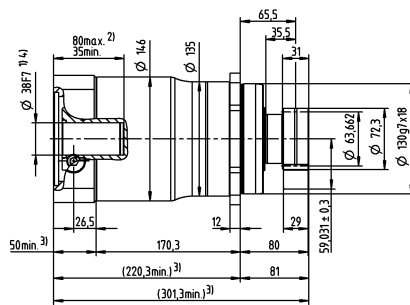
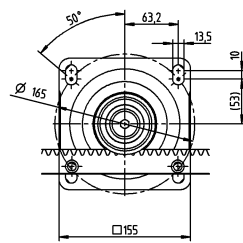

Motor shaft diameter [mm]

Non-tolerated dimensions are nominal dimensions
Detailed rack dimensions starting on page 161

¹⁾ Check motor shaft fit

²⁾ Min./Max. permissible motor shaft length. Longer motor shafts are possible, please contact alpha.

³⁾ The dimensions depend on the motor

⁴⁾ Smaller motor shaft diameter is compensated by a bushing with a minimum thickness of 1 mm

Advanced Linear System ALS 12 with SP+

Planetary gearbox SP+ 180 MF with rack module 4 and pinion RMS module 4

System	Max. feed force ¹⁾ F_{2T}	12500 N	
	Max. feed speed ²⁾ v_{max}	400 m/min	83 m/min
Gearbox	No. of stages	1	2
	Ratios i	3 / 4 / 5 / 7 / 8 / 10	16 / 20 / 25 / 28 / 32 / 35 / 40 / 50 / 64 / 70 / 100
	Clamping hub diameter	38 / 48 / 55 mm	24 / 32 / 38 / 48 mm
	Designation	SP 180S-MF1-_-_-_-2_-_-	SP 180S-MF2-_-_-_-2_-_-
Pinion	Module m	4 mm	
	Number of teeth z	20	
	Pitch circle diameter d	84.883 mm	
	Profile correction factor x	0.4	
	Helix angle β	-19.5283° (left-handed)	
	Designation	RMS 400-323-20L1-055	
Rack	Module m	4 mm	
	Length L (options)	1000 mm (2000 mm, 493 mm)	
	Helix angle β	19.5283° (right-handed)	
	Designation	ZST 400-332-1000-R1; optionally with INIRA®	
Lubrication system ³⁾	Set consisting of lubrication pinion and axis for	Rack	LMT 400-PU -18L1-040-1
		Pinion	LMT 400-PU -18R1-040-1
	Lubricator	125 cm ³	LUC+125-0511-02
		400 cm ³	LUC+400-0511-02
	Lubricant	WITTENSTEIN alpha G11	

¹⁾ Maximum feed force depending on ratio and number of stages

²⁾ Calculation with lowest ratio and maximum input speed

³⁾ Impulse-controlled basic version with one output and 2 m hose. See page 118 for further information on the lubrication system.

Application-specific dimensioning with cymex® – www.wittenstein-cymex.com

Alternative system solutions

Pinion			Axis distance	SP+ 180S	SK+ 180S	SPC+ 180S	SPK+ 180S	Rack*
Designation	d [mm]	x []	A [mm]	F_{2T} [N]	F_{2T} [N]	F_{2T} [N]	F_{2T} [N]	Designation
RMS 400-323-20L1-055	84.883	0.4	79.041	12500	13100	12500	12500	ZST 400-332-1000-R1; optionally with INIRA®

d = Pitch circle diameter

x = Addendum modification coefficient

A = Distance between pinion axle and rear surface of rack

F_{2T} = Maximum feed force depending on ratio and number of stages

Application-specific dimensioning with cymex® – www.wittenstein-cymex.com

* Other length options available

1-stage

greater than 38 (K)
up to 48⁴⁾ (M)
clamping hub
diameters

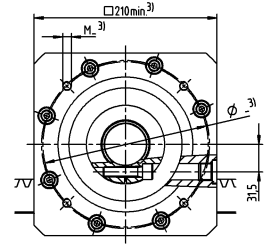
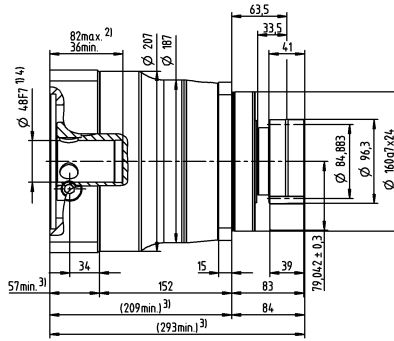
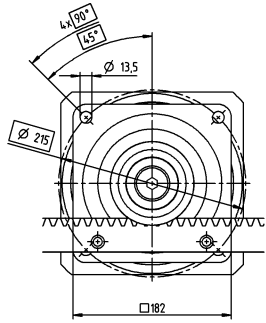

up to 55⁴⁾ (N)
clamping hub
diameters

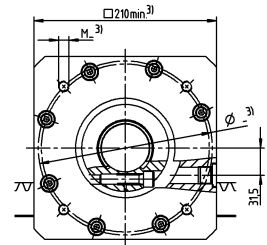
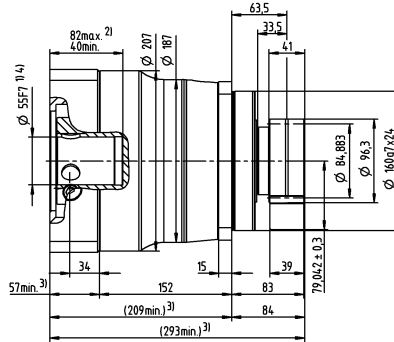
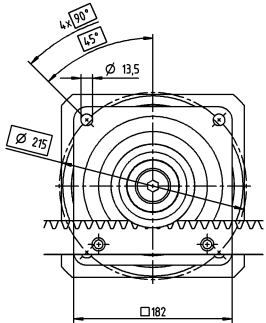

2-stage

greater than 24 (G)
up to 32/38⁴⁾ (I/K)
clamping hub
diameters

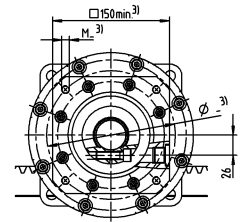
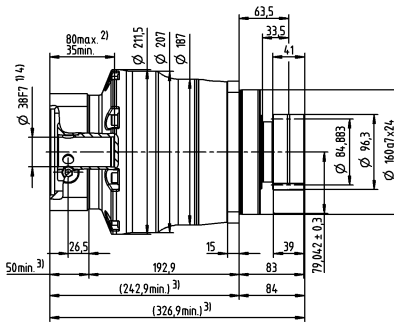
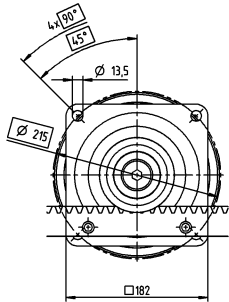

up to 48⁴⁾ (M)
clamping hub
diameters

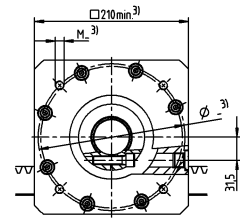
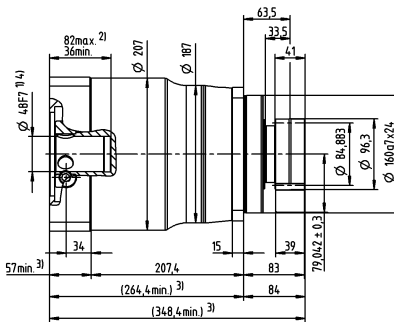
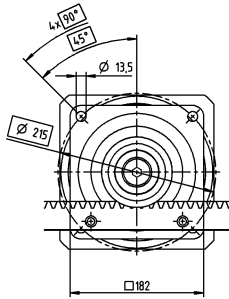

Motor shaft diameter [mm]

Non-tolerated dimensions are nominal dimensions
Detailed rack dimensions starting on page 161
1) Check motor shaft fit
2) Min./Max. permissible motor shaft length. Longer motor shafts are possible, please contact alpha.
3) The dimensions depend on the motor
4) Smaller motor shaft diameter is compensated by a bushing with a minimum thickness of 1 mm

Advanced Linear Systems

Advanced Linear System ALS 1 with TP+

Planetary gearbox TP+ 004 MF with rack module 2 and pinion RMF module 2

System	Max. feed force ¹⁾ F_{2T}	1370 N	
	Max. feed speed ²⁾ v_{\max}	325 m/min	81 m/min
Gearbox	No. of stages	1	2
	Ratios i	4 / 5 / 7 / 8 / 10	16 / 20 / 21 / 25 / 28 / 31 / 32 / 35 / 40 / 50 / 61 / 64 / 70 / 91 / 100
	Clamping hub diameter	11 / 14 / 19 mm	11 / 14 mm
	Designation	TP 004S-MF1-_-_-_-0_-	TP 004S-MF2-_-_-_-0_-
Pinion	Module m	2 mm	
	Number of teeth z	26	
	Pitch circle diameter d	55.174 mm	
	Profile correction factor x	0.4	
	Helix angle β	-19.5283° (left-handed)	
	Designation	RMF 200-443-26L1-031-8xM5	
Rack	Module m	2 mm	
	Length L (options)	1000 mm (2000 mm; 500 mm)	
	Helix angle β	19.5283° (right-handed)	
	Designation	ZST 200-332-1000-R1; optionally with INIRA®	
Lubrication system ³⁾	Set consisting of lubrication pinion and axis for	Rack	LMT 200-PU -18L1-024-1
		Pinion	LMT 200-PU -18R1-024-1
	Lubricator	125 cm ³	LUC+125-0511-02
		400 cm ³	LUC+400-0511-02
	Lubricant	WITTENSTEIN alpha G11	

¹⁾ Maximum feed force depending on ratio and number of stages

²⁾ Calculation with lowest ratio and maximum input speed

³⁾ Impulse-controlled basic version with one output and 2 m hose. See page 118 for further information on the lubrication system.

Application-specific dimensioning with cymex® – www.wittenstein-cymex.com

Alternative system solutions

Pinion			Axis distance	TP+ 004S	PAG 1	TK+ 004S	TPC+ 004S	Rack*
Designation	d [mm]	x []	A [mm]	F_{2T} [N]	F_{2T} [N]	F_{2T} [N]	F_{2T} [N]	Designation
RMF 200-443-26L1-031-8xM5	55.174	0.4	50.387	1370	1370	1300	1370	ZST 200-332-1000-R1; optionally with INIRA®

d = Pitch circle diameter

x = Addendum modification coefficient

A = Distance between pinion axle and rear surface of rack

F_{2T} = Maximum feed force depending on ratio and number of stages

Application-specific dimensioning with cymex® – www.wittenstein-cymex.com

* Other length options available

1-stage

greater than 11 (B) up to 14 (C) clamping hub diameters

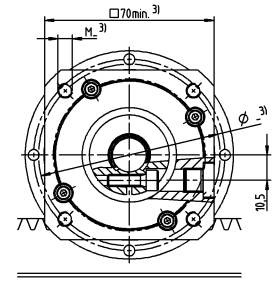
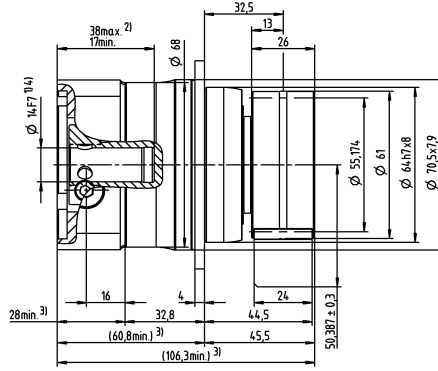
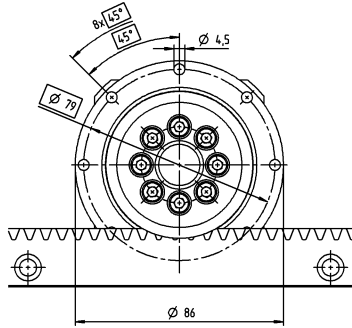

up to 19 (E) clamping hub diameters

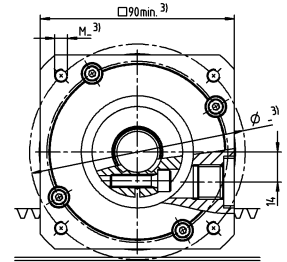
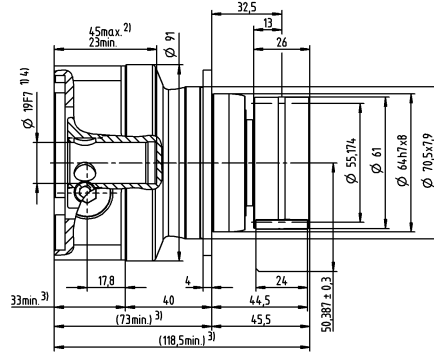
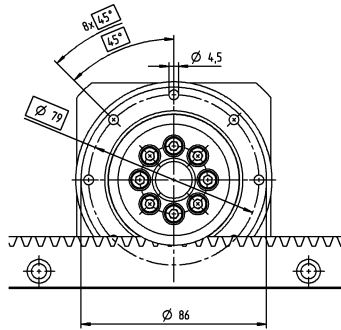

2-stage

up to 11 (B) clamping hub diameters

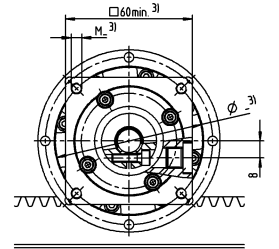
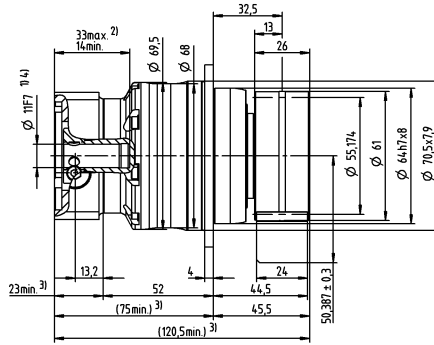
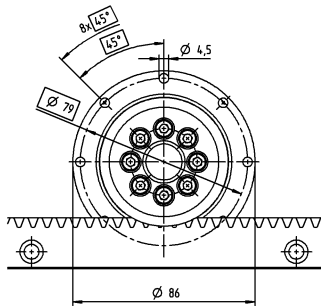

up to 14 (C) clamping hub diameters

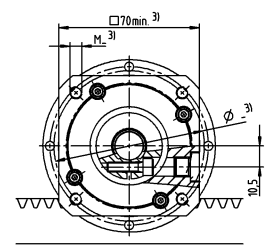
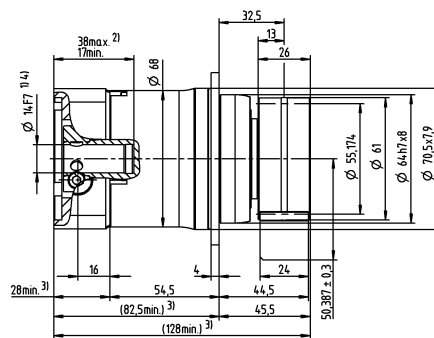
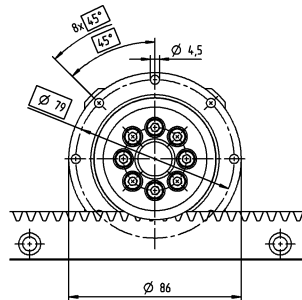

Motor shaft diameter [mm]

Non-tolerated dimensions are nominal dimensions
 Detailed rack dimensions starting on page 161
¹⁾ Check motor shaft fit
²⁾ Min./Max. permissible motor shaft length. Longer motor shafts are possible, please contact alpha.
³⁾ The dimensions depend on the motor
⁴⁾ Smaller motor shaft diameter is compensated by a bushing with a minimum thickness of 1 mm

Advanced Linear Systems

Advanced Linear System ALS 2 with TP+

Planetary gearbox TP+ 010 MF with rack module 2 and pinion RMF module 2

System	Max. feed force ¹⁾ F_{zT}	2500 N	
	Max. feed speed ²⁾ v_{max}	412 m/min	103 m/min
Gearbox	No. of stages	1	2
	Ratios i	4 / 5 / 7 / 8 / 10	16 / 20 / 21 / 25 / 28 / 31 / 32 / 35 / 40 / 50 / 61 / 64 / 70 / 91 / 100
	Clamping hub diameter	14 / 19 / 24 mm	11 / 14 / 19 mm
	Designation	TP 010S-MF1-_-_-_-0_-_-	TP 010S-MF2-_-_-_-0_-_-
Pinion	Module m	2 mm	
	Number of teeth z	33	
	Pitch circle diameter d	70.028 mm	
	Profile correction factor x	0.3	
	Helix angle β	-19.5283° (left-handed)	
	Designation	RMF 200-443-33L1-050-8xM6	
Rack	Module m	2 mm	
	Length L (options)	1000 mm (2000 mm; 500 mm)	
	Helix angle β	19.5283° (right-handed)	
	Designation	ZST 200-332-1000-R1; optionally with INIRA®	
Lubrication system ³⁾	Set consisting of lubrication pinion and axis for	Rack	LMT 200-PU -18L1-024-1
		Pinion	LMT 200-PU -18R1-024-1
	Lubricator	125 cm ³	LUC+125-0511-02
		400 cm ³	LUC+400-0511-02
	Lubricant	WITTENSTEIN alpha G11	

¹⁾ Maximum feed force depending on ratio and number of stages

²⁾ Calculation with lowest ratio and maximum input speed

³⁾ Impulse-controlled basic version with one output and 2 m hose. See page 118 for further information on the lubrication system. Application-specific dimensioning with cymex® – www.wittenstein-cymex.com

Alternative system solutions

Pinion			Axis distance	TP+ 010S	PAG 2	TK+ 010S	TPK+ 010S	TPC+ 010S	Rack*
Designation	d [mm]	x []	A [mm]	F_{zT} [N]	F_{zT} [N]	F_{zT} [N]	F_{zT} [N]	F_{zT} [N]	Designation
RMF 200-443-29L1-050-8xM6	61.540	0.3	53.370	2290	2290	3030	2290	2290	ZST 200-332-1000-R1; optionally with INIRA®
RMF 200-443-33L1-050-8xM6	70.028	0.3	57.614	2500	2500	2380	2500	2500	ZST 200-332-1000-R1; optionally with INIRA®
RMF 200-443-37L1-050-8xM6	78.517	0.3	61.858	2470	2470	2120	2470	2470	ZST 200-332-1000-R1; optionally with INIRA®
RMW 200-444-20L1-037	42.441	0.4	44.021	2280	2280	-	2280	2280	ZST 200-332-1000-R1; optionally with INIRA®

d = Pitch circle diameter

x = Addendum modification coefficient

A = Distance between pinion axle and rear surface of rack

F_{zT} = Maximum feed force depending on ratio and number of stages

Application-specific dimensioning with cymex® – www.wittenstein-cymex.com

* Other length options available

1-stage

greater than 14 (C) up to 19⁴⁾ (E) clamping hub diameters

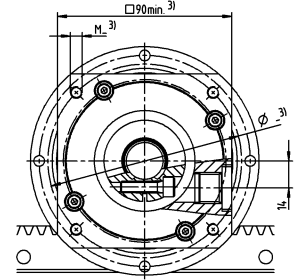
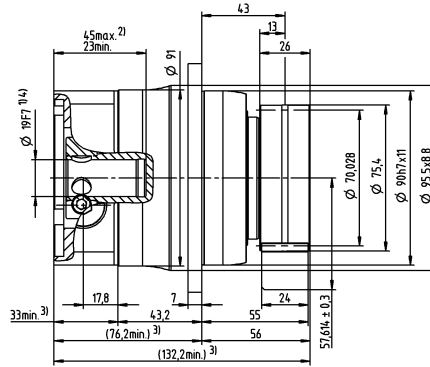
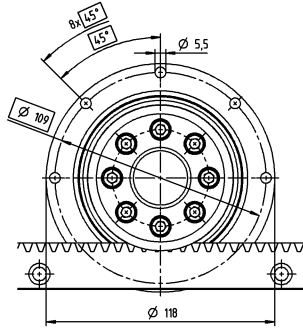

up to 24⁴⁾ (G) clamping hub diameters

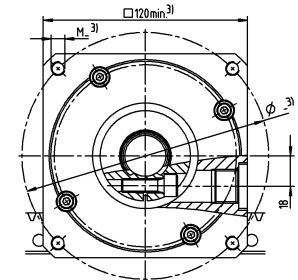
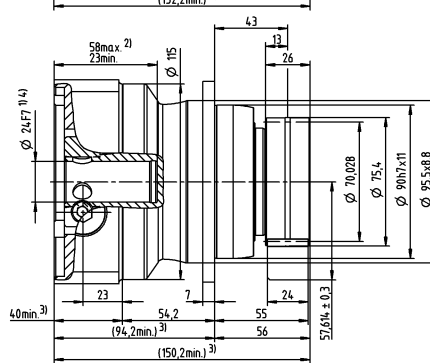
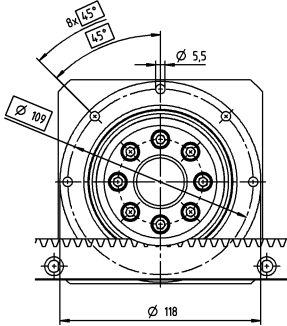

2-stage

greater than 11 (B) up to 14⁴⁾ (C) clamping hub diameters

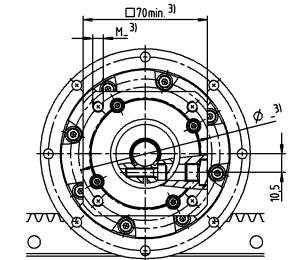
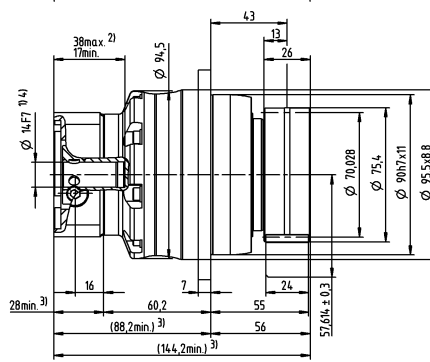
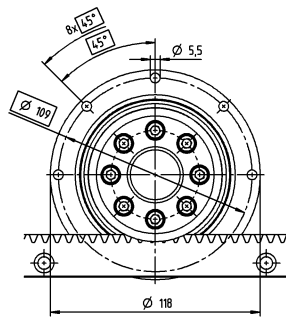

up to 19⁴⁾ (E) clamping hub diameters

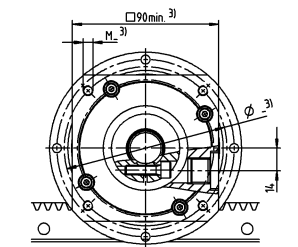
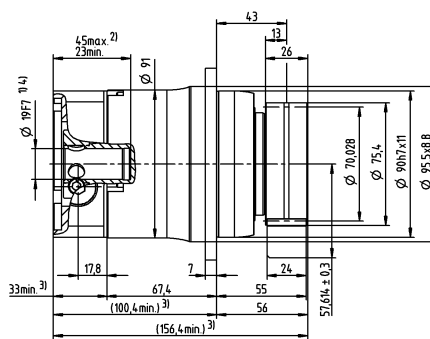
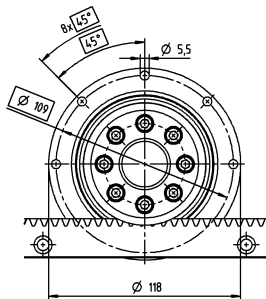

Motor shaft diameter [mm]

Non-tolerated dimensions are nominal dimensions
Detailed rack dimensions starting on page 161

- ¹⁾ Check motor shaft fit
- ²⁾ Min./Max. permissible motor shaft length. Longer motor shafts are possible, please contact alpha.
- ³⁾ The dimensions depend on the motor
- ⁴⁾ Smaller motor shaft diameter is compensated by a bushing with a minimum thickness of 1 mm

Advanced Linear System ALS 3 with TP+

Planetary gearbox TP+ 025 MF with rack module 2 and pinion RMF module 2

System	Max. feed force ¹⁾ F_{2T}		3600 N	
	Max. feed speed ²⁾ v_{max}		367 m/min	125 m/min
Gearbox	No. of stages		1	2
	Ratios i		4 / 5 / 7 / 8 / 10	16 / 20 / 21 / 25 / 28 / 31 / 32 / 35 / 40 / 50 / 61 / 64 / 70 / 91 / 100
	Clamping hub diameter		19 / 24 / 28 / 38 mm	14 / 19 / 24 mm
	Designation		TP 025S-MF1-_-_-_-0_-_-	TP 025S-MF2-_-_-_-0_-_-
Pinion	Module m		2 mm	
	Number of teeth z		40	
	Pitch circle diameter d		84.883 mm	
	Profile correction factor x		0.3	
	Helix angle β		-19.5283° (left-handed)	
	Designation		RMF 200-443-40L1-063-12xM6	
Rack	Module m		2 mm	
	Length L (options)		1000 mm (2000 mm; 500 mm)	
	Helix angle β		19.5283° (right-handed)	
	Designation		ZST 200-332-1000-R1; optionally with INIRA®	
Lubrication system ³⁾	Set consisting of lubrication pinion and axis for	Rack	LMT 200-PU -18L1-024-1	
		Pinion	LMT 200-PU -18R1-024-1	
	Lubricator	125 cm ³	LUC+125-0511-02	
		400 cm ³	LUC+400-0511-02	
	Lubricant		WITTENSTEIN alpha G11	

¹⁾ Maximum feed force depending on ratio and number of stages

²⁾ Calculation with lowest ratio and maximum input speed

³⁾ Impulse-controlled basic version with one output and 2 m hose. See page 118 for further information on the lubrication system.

Application-specific dimensioning with cymex® – www.wittenstein-cymex.com

Alternative system solutions

Pinion			Axis distance	TP+ 025S	PAG 3	TK+ 025S	TPK+ 025S	TPC+ 025S	Rack*
Designation	d [mm]	x []	A [mm]	F_{2T} [N]	F_{2T} [N]	F_{2T} [N]	F_{2T} [N]	F_{2T} [N]	Designation
RMF 200-443-35L1-063-12xM6	74.272	0.3	59.736	3330	3330	4300	3330	3330	ZST 200-332-1000-R1; optionally with INIRA®
RMF 200-443-40L1-063-12xM6	84.883	0.3	65.041	3600	3600	3990	3600	3600	ZST 200-332-1000-R1; optionally with INIRA®
RMF 200-443-45L1-063-12xM6	95.493	0.22	70.187	3580	3580	3540	3580	3580	ZST 200-332-1000-R1; optionally with INIRA®
RMW 200-444-20L1-037	42.441	0.4	44.021	3370	3370	–	3370	3370	ZST 200-332-1000-R1; optionally with INIRA®
RMW 300-444-20L1-055	63.662	0.4	59.031	3220	3220	–	3220	3220	ZST 300-332-1000-R1; optionally with INIRA®

d = Pitch circle diameter

x = Addendum modification coefficient

A = Distance between pinion axle and rear surface of rack

F_{2T} = Maximum feed force depending on ratio and number of stages

Application-specific dimensioning with cymex® – www.wittenstein-cymex.com

* Other length options available

1-stage

greater than 19 (E)
up to 24/28⁴⁾ (G/H)
clamping hub
diameters

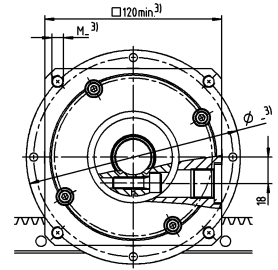
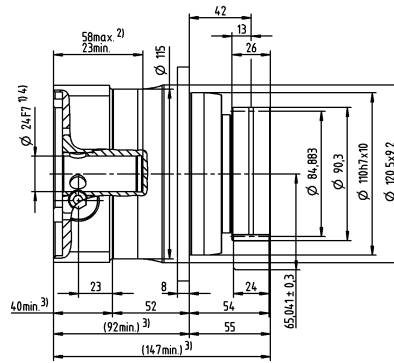
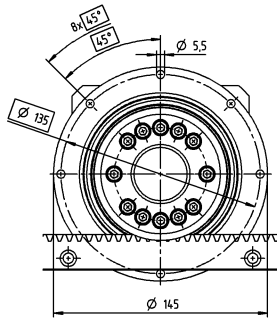

up to 38⁴⁾ (K)
clamping hub
diameters

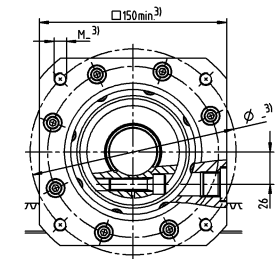
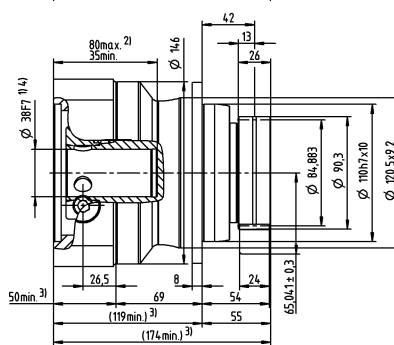
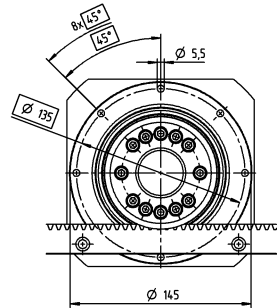

2-stage

greater than 14 (C)
up to 19⁴⁾ (E)
clamping hub
diameters

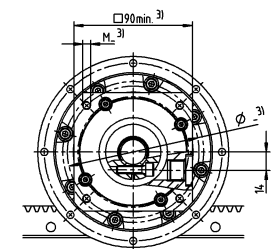
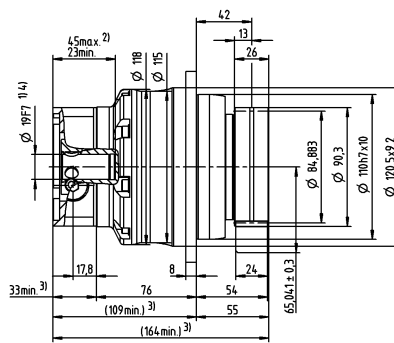
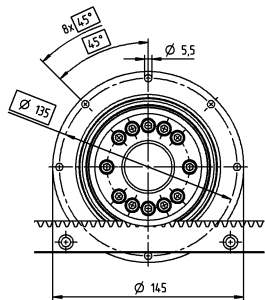

up to 24/28⁴⁾ (G/H)
clamping hub
diameters

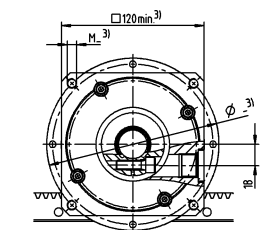
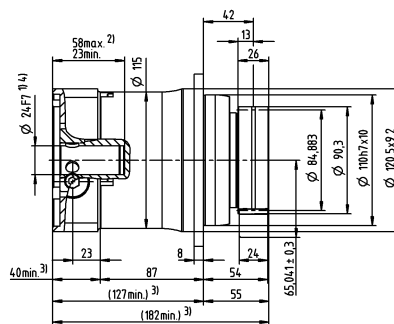
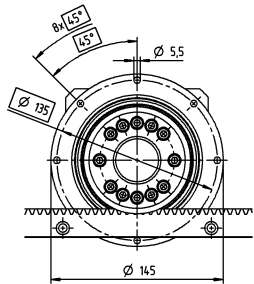

Motor shaft diameter [mm]

Non-tolerated dimensions are nominal dimensions
Detailed rack dimensions starting on page 161

- ¹⁾ Check motor shaft fit
- ²⁾ Min./Max. permissible motor shaft length. Longer motor shafts are possible, please contact alpha.
- ³⁾ The dimensions depend on the motor
- ⁴⁾ Smaller motor shaft diameter is compensated by a bushing with a minimum thickness of 1 mm

Advanced Linear System ALS 12 with TP+

Planetary gearbox TP+ 050 MF with rack module 3 and pinion RMF module 3

System	Max. feed force ¹⁾ F_{zT}	11800 N	
	Max. feed speed ²⁾ v_{max}	438 m/min	137 m/min
Gearbox	No. of stages	1	2
	Ratios i	4 / 5 / 7 / 8 / 10	16 / 20 / 21 / 25 / 28 / 31 / 32 / 35 / 40 / 50 / 61 / 64 / 70 / 91 / 100
	Clamping hub diameter	24 / 32 / 38 / 48 mm	19 / 24 / 38 mm
	Designation	TP 050S-MF1-_-_-_-0_-_-	TP 050S-MF2-_-_-_-0_-_-
Pinion	Module m	3 mm	
	Number of teeth z	35	
	Pitch circle diameter d	111.409 mm	
	Profile correction factor x	0.3	
	Helix angle β	-19.5283° (left-handed)	
	Designation	RMF 300-443-35L1-080-12xM8	
Rack	Module m	3	
	Length L (options)	1000 mm (2000 mm; 500 mm)	
	Helix angle β	19.5283° (right-handed)	
	Designation	ZST 300-332-1000-R1; optionally with INIRA®	
Lubrication system ³⁾	Set consisting of lubrication pinion and axis for	Rack	LMT 300-PU -18L1-030-1
		Pinion	LMT 300-PU -18R1-030-1
	Lubricator	125 cm ³	LUC+125-0511-02
		400 cm ³	LUC+400-0511-02
	Lubricant	WITTENSTEIN alpha G11	

¹⁾ Maximum feed force depending on ratio and number of stages

²⁾ Calculation with lowest ratio and maximum input speed

³⁾ Impulse-controlled basic version with one output and 2 m hose. See page 118 for further information on the lubrication system.

Application-specific dimensioning with cymex® – www.wittenstein-cymex.com

Alternative system solutions

Pinion			Axis distance	TP+ 050S	TK+ 050S	TPK+ 050S	TPC+ 050S	Rack*
Designation	d [mm]	x []	A [mm]	F_{zT} [N]	F_{zT} [N]	F_{zT} [N]	F_{zT} [N]	Designation
RMF 300-443-31L1-080-12xM8	98.676	0.3	76.238	10600	7250	10600	10600	ZST 300-332-1000-R1; optionally with INIRA®
RMF 300-443-35L1-080-12xM8	111.409	0.3	82.604	11800	6450	11800	11800	ZST 300-332-1000-R1; optionally with INIRA®
RMF 300-443-40L1-080-12xM8	127.324	0.3	90.562	11100	5600	11100	10900	ZST 300-332-1000-R1; optionally with INIRA®
RMW 300-444-20L1-055	63.662	0.4	59.031	10900	–	10900	10900	ZST 300-332-1000-R1; optionally with INIRA®
RMW 400-444-20L1-073	84.882	0.2	78.241	10350	–	10350	10350	ZST 400-332-1000-R1; optionally with INIRA®

d = Pitch circle diameter

x = Addendum modification coefficient

A = Distance between pinion axle and rear surface of rack

F_{zT} = Maximum feed force depending on ratio and number of stages

Application-specific dimensioning with cymex® – www.wittenstein-cymex.com

* Other length options available

1-stage

greater than 24 (G)
up to 32/38⁴⁾ (I/K)
clamping hub
diameters

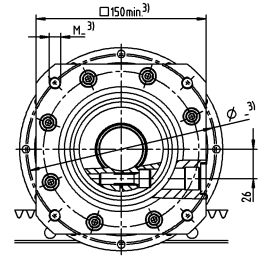
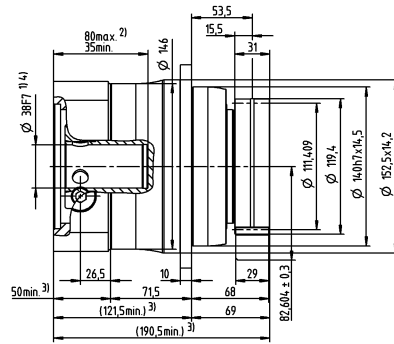
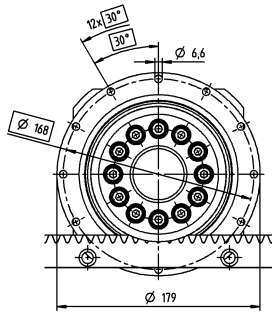

up to 48⁴⁾ (M)
clamping hub
diameters

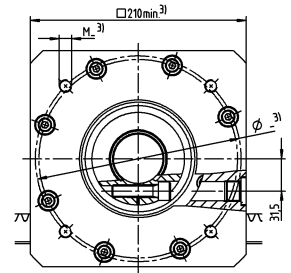
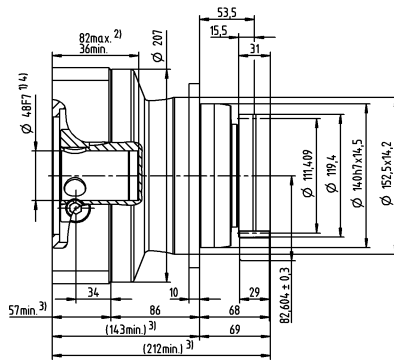
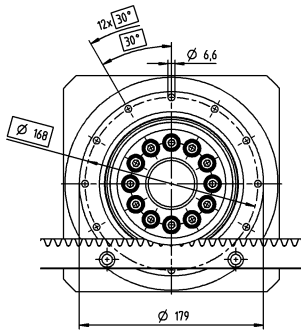

2-stage

greater than 19 (E)
up to 24⁴⁾ (G)
clamping hub
diameters

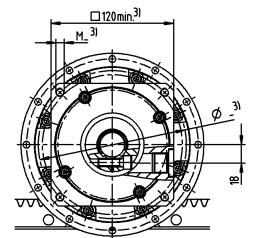
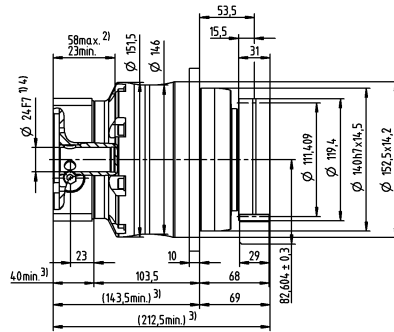
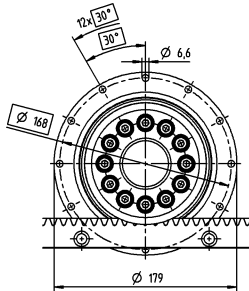

up to 38⁴⁾ (K)
clamping hub
diameters

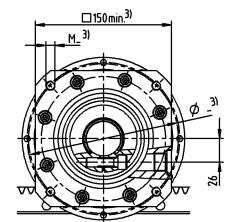
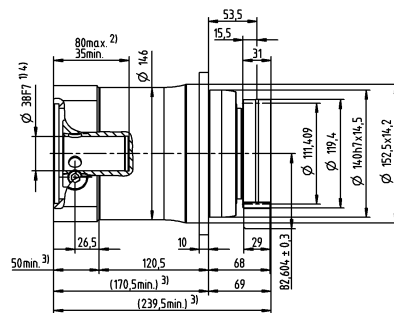
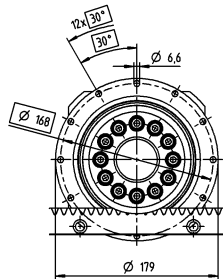

Motor shaft diameter [mm]

Non-tolerated dimensions are nominal dimensions
Detailed rack dimensions starting on page 161

¹⁾ Check motor shaft fit

²⁾ Min./Max. permissible motor shaft length. Longer motor shafts are possible, please contact alpha.

³⁾ The dimensions depend on the motor

⁴⁾ Smaller motor shaft diameter is compensated by a bushing with a minimum thickness of 1 mm

Advanced Linear System ALS 20 with TP+

Planetary gearbox TP+ 110 MF with rack module 4 and pinion RMF module 4

System	Max. feed force ¹⁾ F_{2T}	19700 N	
	Max. feed speed ²⁾ v_{max}	570 m/min	178 m/min
Gearbox	No. of stages	1	2
	Ratios i	4 / 5 / 7 / 8 / 10	16 / 20 / 21 / 25 / 28 / 31 / 32 / 35 / 40 / 50 / 61 / 64 / 70 / 91 / 100
	Clamping hub diameter	38 / 48 / 55 mm	24 / 32 / 38 / 48 mm
	Designation	TP 110S-MF1-___-0_ _	TP 110S-MF2-___-0_ _
Pinion	Module m	4 mm	
	Number of teeth z	38	
	Pitch circle diameter d	161.277 mm	
	Profile correction factor x	0.25	
	Helix angle β	-19.5283° (left-handed)	
	Designation	RMF 400-443-38L1-125-12xM10	
Rack	Module m	4 mm	
	Length L (options)	1000 mm (2000 mm, 493 mm)	
	Helix angle β	19.5283° (right-handed)	
	Designation	ZST 400-334-1000-R15; optionally with INIRA®	
Lubrication system ³⁾	Set consisting of lubrication pinion and axis for	Rack	LMT 400-PU -18L1-040-1
		Pinion	LMT 400-PU -18R1-040-1
	Lubricator	125 cm ³	LUC+125-0511-02
		400 cm ³	LUC+400-0511-02
	Lubricant	WITTENSTEIN alpha G11	

¹⁾ Maximum feed force depending on ratio and number of stages

²⁾ Calculation with lowest ratio and maximum input speed

³⁾ Impulse-controlled basic version with one output and 2 m hose. See page 118 for further information on the lubrication system.

Application-specific dimensioning with cymex® – www.wittenstein-cymex.com

Alternative system solutions

Pinion			Axis distance	TP+ 110S	TPK+ 110S	TPC+ 110S	Rack*
Designation	d [mm]	x []	A [mm]	F_{2T} [N]	F_{2T} [N]	F_{2T} [N]	Designation
RMF 400-443-38L1-125-12xM10	161.277	0.25	116.639	19700	19700	19700	ZST 400-332-1000-R15; optionally with INIRA®
RMW 400-444-20L1-073	84.882	0.2	78.241	21000	21000	21000	ZST 400-332-1000-R15; optionally with INIRA®
RMW 500-444-19L1-089	100.798	0.4	86.399	20000	20000	20000	ZST 500-332-1000-R1; optionally with INIRA®

d = Pitch circle diameter

x = Addendum modification coefficient

A = Distance between pinion axle and rear surface of rack

F_{2T} = Maximum feed force depending on ratio and number of stages

Application-specific dimensioning with cymex® – www.wittenstein-cymex.com

* Other length options available

Advanced Linear System ALS 4 with TP+ MA

Planetary gearbox TP+ 025 MA with rack module 2 and pinion RMW module 2

System	Max. feed force ¹⁾ F_{zT}		4200 N	
	Max. feed speed ²⁾ v_{max}		45 m/min	15 m/min
Gearbox	No. of stages		2	3
	Ratios i		22 / 27.5 / 38.5 / 55	66 / 88 / 110 / 154 / 220
	Clamping hub diameter		19 / 24 mm	19 mm
	Designation		TP 025S-MA2-_-_-_-3_-_-	TP 025S-MA3-_-_-_-3_-_-
Pinion	Module m		2 mm	
	Number of teeth z		20	
	Pitch circle diameter d		42.441 mm	
	Profile correction factor x		0.4	
	Helix angle β		-19.5283° (left-handed)	
	Designation		RMW 200-444-20L1-037	
Rack	Module m		2 mm	
	Length L (options)		1000 mm (2000 mm; 500 mm)	
	Helix angle β		19.5283° (right-handed)	
	Designation		ZST 200-332-1000-R1; optionally with INIRA®	
Lubrication system ³⁾	Set consisting of lubrication pinion and axis for	Rack	LMT 200-PU -18L1-024-1	
		Pinion	LMT 200-PU -18R1-024-1	
	Lubricator	125 cm ³	LUC+125-0511-02	
		400 cm ³	LUC+400-0511-02	
	Lubricant		WITTENSTEIN alpha G11	

¹⁾ Maximum feed force depending on ratio and number of stages

²⁾ Calculation with lowest ratio and maximum input speed

³⁾ Impulse-controlled basic version with one output and 2 m hose. See page 118 for further information on the lubrication system.
Application-specific dimensioning with cymex® – www.wittenstein-cymex.com

Alternative system solutions

Pinion			Axis distance	TP+ 025S HIGH TORQUE	TPM+ 025 HIGH TORQUE	TPK+ 025S HIGH TORQUE	Rack*
Designation	d [mm]	x []	A [mm]	F_{zT} [N]	F_{zT} [N]	F_{zT} [N]	Designation
RMW 200-444-20L1-037	42.441	0.4	44.021	4200	4200	4200	ZST 200-332-1000-R1; optionally with INIRA®
RMW 300-444-20L1-055	63.662	0.4	59.031	4050	4050	4050	ZST 300-332-1000-R1; optionally with INIRA®
RMF 200-443-40L1-063-12xM8	84.883	0.3	65.041	4500	4500	4500	ZST 200-332-1000-R1; optionally with INIRA®

d = Pitch circle diameter

x = Addendum modification coefficient

A = Distance between pinion axle and rear surface of rack

F_{zT} = Maximum feed force depending on ratio and number of stages

Application-specific dimensioning with cymex® – www.wittenstein-cymex.com

* Other length options available

2-stage

up to 19⁴⁾ (E)
clamping hub
diameters

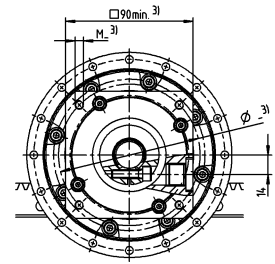
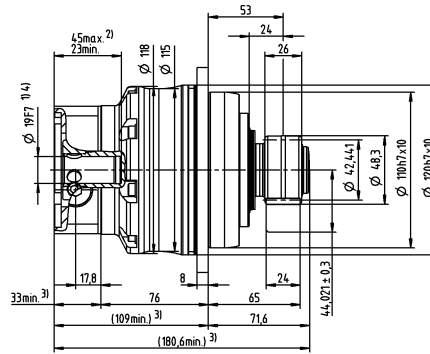
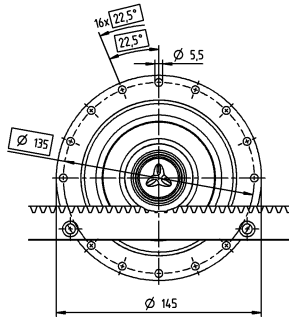

up to 24⁴⁾ (G)
clamping hub
diameters

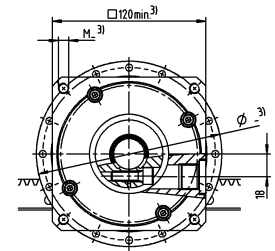
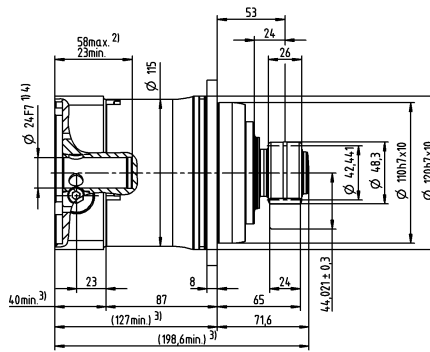
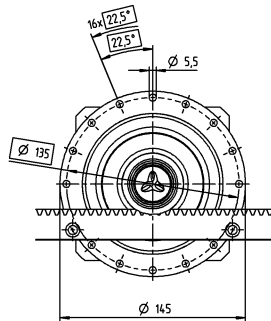

3-stage

up to 19⁴⁾ (E)
clamping hub
diameters

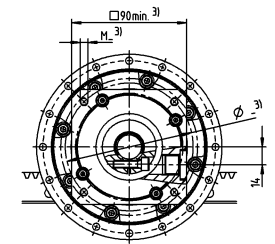
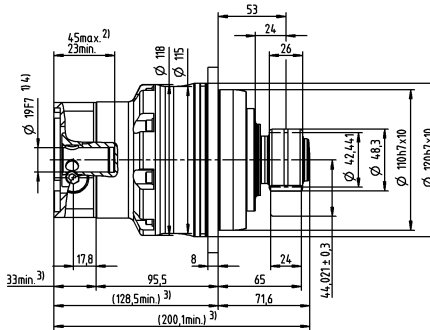
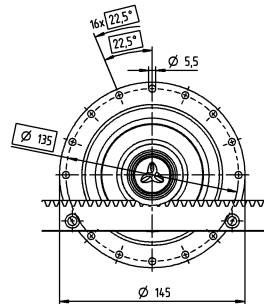

Motor shaft diameter [mm]

Advanced Linear Systems

Non-tolerated dimensions are nominal dimensions
Detailed rack dimensions starting on page 161

- ¹⁾ Check motor shaft fit
- ²⁾ Min./Max. permissible motor shaft length. Longer motor shafts are possible, please contact alpha.
- ³⁾ The dimensions depend on the motor
- ⁴⁾ Smaller motor shaft diameter is compensated by a bushing with a minimum thickness of 1 mm

Advanced Linear System ALS 11 with TP+ MA

Planetary gearbox TP+ 050 MA with rack module 3 and pinion RMW module 3

System	Max. feed force ¹⁾ F_{zT}		10900 N	
	Max. feed speed ²⁾ v_{max}		57 m/min	19 m/min
Gearbox	No. of stages		2	3
	Ratios i		22 / 27.5 / 38.5 / 55	66 / 88 / 110 / 154 / 220
	Clamping hub diameter		24 / 38 mm	24 mm
	Designation		TP 050S-MA2-_-_-_-3_-_-	TP 050S-MA3-_-_-_-3_-_-
Pinion	Module m		3 mm	
	Number of teeth z		20	
	Pitch circle diameter d		63.662 mm	
	Profile correction factor x		0.4	
	Helix angle β		-19.5283° (left-handed)	
	Designation		RMW 300-444-20L1-055	
Rack	Module m		3 mm	
	Length L (options)		1000 mm (2000 mm; 500 mm)	
	Helix angle β		19.5283° (right-handed)	
	Designation		ZST 300-332-1000-R1; optionally with INIRA®	
Lubrication system ³⁾	Set consisting of lubrication pinion and axis for	Rack	LMT 300-PU -18L1-030-1	
		Pinion	LMT 300-PU -18R1-030-1	
	Lubricator	125 cm ³	LUC+125-0511-02	
		400 cm ³	LUC+400-0511-02	
	Lubricant		WITTENSTEIN alpha G11	

¹⁾ Maximum feed force depending on ratio and number of stages

²⁾ Calculation with lowest ratio and maximum input speed

³⁾ Impulse-controlled basic version with one output and 2 m hose. See page 118 for further information on the lubrication system.
Application-specific dimensioning with cymex® – www.wittenstein-cymex.com

Alternative system solutions

Pinion			Axis distance	TP+ 050S HIGH TORQUE	TPM+ 050 HIGH TORQUE	TPK+ 050S HIGH TORQUE	Rack*
Designation	d [mm]	x []	A [mm]	F_{zT} [N]	F_{zT} [N]	F_{zT} [N]	Designation
RMW 300-444-20L1-055	63.662	0.4	59.031	10900	10900	10900	ZST 300-332-1000-R1; optionally with INIRA®
RMW 400-444-20L1-073	84.882	0.2	78.241	10300	10300	10300	ZST 400-332-1000-R1; optionally with INIRA®
RMF 300-443-35L1-080-12xM10	111.409	0.3	82.604	11800	11800	11800	ZST 300-332-1000-R1; optionally with INIRA®
RMF 300-443-40L1-080-12xM10	127.324	0.3	90.562	11700	11700	11700	ZST 300-332-1000-R1; optionally with INIRA®

d = Pitch circle diameter

x = Addendum modification coefficient

A = Distance between pinion axle and rear surface of rack

F_{zT} = Maximum feed force depending on ratio and number of stages

Application-specific dimensioning with cymex® – www.wittenstein-cymex.com

* Other length options available

2-stage

up to 24⁴⁾ (G)
clamping hub
diameters

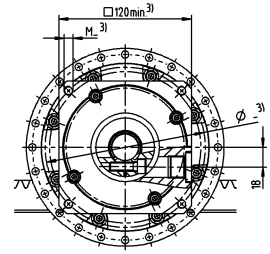
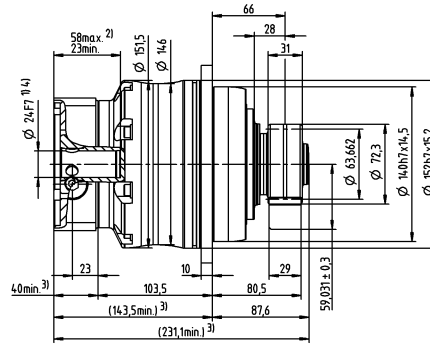
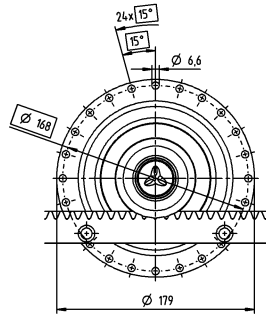

up to 38⁴⁾ (K)
clamping hub
diameters

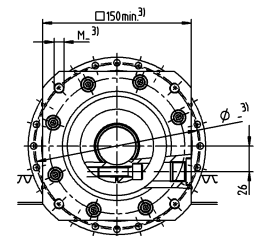
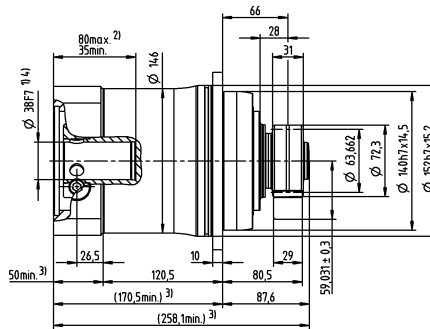
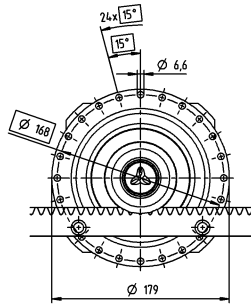

3-stage

up to 24⁴⁾ (G)
clamping hub
diameters

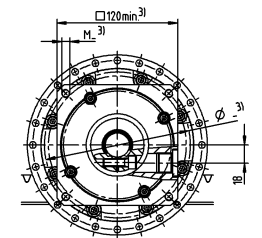
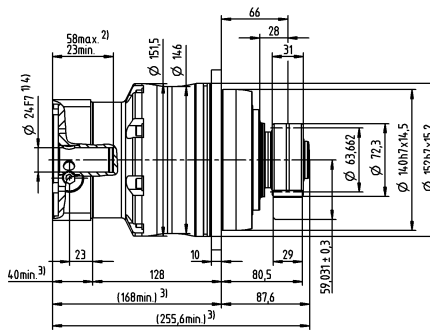
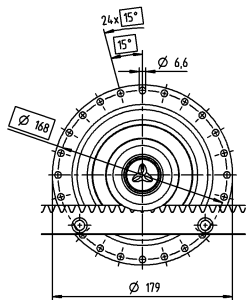

Motor shaft diameter [mm]

Advanced Linear
Systems

Non-tolerated dimensions are nominal dimensions
Detailed rack dimensions starting on page 161

¹⁾ Check motor shaft fit

²⁾ Min./Max. permissible motor shaft length. Longer motor shafts are possible, please contact alpha.

³⁾ The dimensions depend on the motor

⁴⁾ Smaller motor shaft diameter is compensated by a bushing with a minimum thickness of 1 mm

Advanced Linear System ALS 21 with TP+ MA

Planetary gearbox TP+ 110 MA with rack module 4 and pinion RMW module 4

System	Max. feed force ¹⁾ F_{2T}		21000 N	
	Max. feed speed ²⁾ v_{max}		68 m/min	23 m/min
Gearbox	No. of stages		2	3
	Ratios i		22 / 27.5 / 38.5 / 55	66 / 88 / 110 / 154 / 220
	Clamping hub diameter		38 / 48 mm	38 mm
	Designation		TP 110S-MA2-_-_-_-3_ _	TP 110S-MA3-_-_-_-3_ _
Pinion	Module m		4 mm	
	Number of teeth z		20	
	Pitch circle diameter d		84.883 mm	
	Profile correction factor x		0.2	
	Helix angle β		-19.5283° (left-handed)	
	Designation		RMW 400-444-20L1-073	
Rack	Module m		4 mm	
	Length L (options)		1000 mm (2000 mm, 493 mm)	
	Helix angle β		19.5283° (right-handed)	
	Designation		ZST 400-332-1000-R15; optionally with INIRA®	
Lubrication system ³⁾	Set consisting of lubrication pinion and axis for	Rack	LMT 400-PU -18L1-040-1	
		Pinion	LMT 400-PU -18R1-040-1	
	Lubricator	125 cm ³	LUC+125-0511-02	
		400 cm ³	LUC+400-0511-02	
	Lubricant		WITTENSTEIN alpha G11	

¹⁾ Maximum feed force depending on ratio and number of stages

²⁾ Calculation with lowest ratio and maximum input speed

³⁾ Impulse-controlled basic version with one output and 2 m hose. See page 118 for further information on the lubrication system.
Application-specific dimensioning with cymex® – www.wittenstein-cymex.com

Alternative system solutions

Pinion			Axis distance	TP+ 110S HIGH TORQUE	TPM+ 110 HIGH TORQUE	TPK+ 110S HIGH TORQUE	Rack*
Designation	d [mm]	x []	A [mm]	F_{2T} [N]	F_{2T} [N]	F_{2T} [N]	Designation
RMW 400-444-20L1-073	84.882	0.2	78.241	21000	21000	21000	ZST 400-332-1000-R15; optionally with INIRA®
RMW 500-444-19L1-089	100.798	0.4	86.399	20000	20000	20000	ZST 500-332-1000-R1; optionally with INIRA®
RMF 400-443-40L1-125-12xM12	169.766	0	119.883	21700	21700	21700	ZST 400-332-1000-R15; optionally with INIRA®

d = Pitch circle diameter

x = Addendum modification coefficient

A = Distance between pinion axle and rear surface of rack

F_{2T} = Maximum feed force depending on ratio and number of stages

Application-specific dimensioning with cymex® – www.wittenstein-cymex.com

* Other length options available

2-stage

up to 38⁴⁾ (K)
clamping hub
diameters

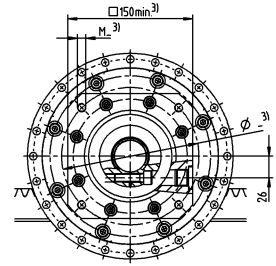
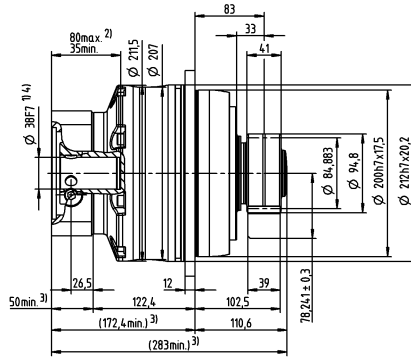
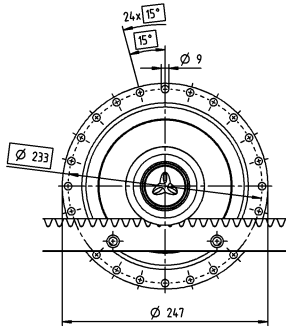

up to 48⁴⁾ (M)
clamping hub
diameters

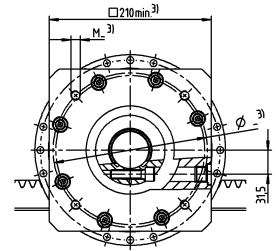
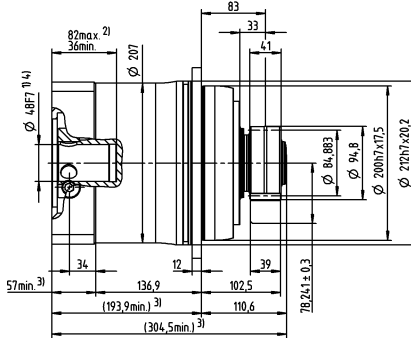
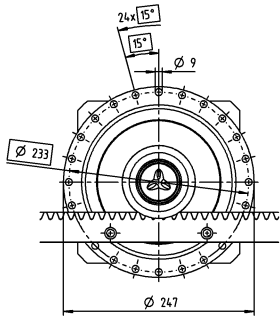

3-stage

up to 38⁴⁾ (K)
clamping hub
diameters

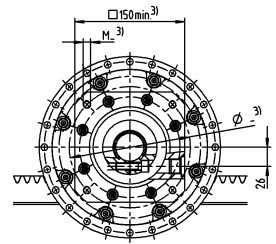
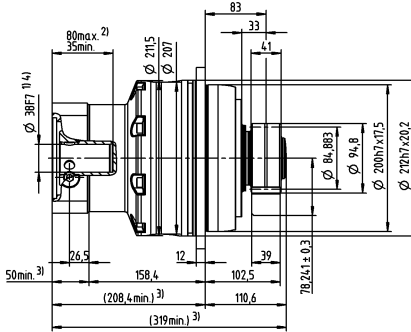
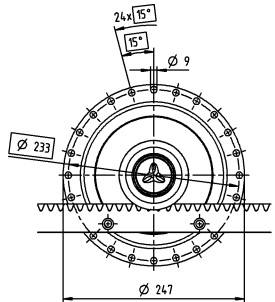

Motor shaft diameter [mm]

Advanced Linear Systems

Non-tolerated dimensions are nominal dimensions
Detailed rack dimensions starting on page 161
1) Check motor shaft fit
2) Min./Max. permissible motor shaft length. Longer motor shafts are possible, please contact alpha.
3) The dimensions depend on the motor
4) Smaller motor shaft diameter is compensated by a bushing with a minimum thickness of 1 mm