

alpha Basic Line & alpha Value Line Product catalog

Reliable
Flexible
Economical

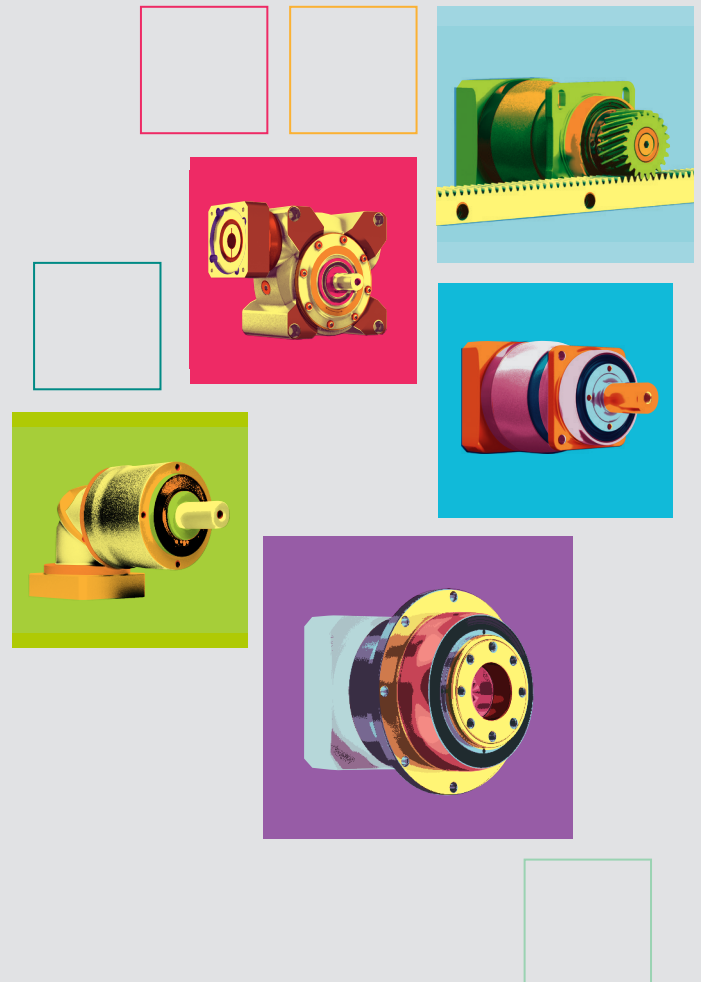
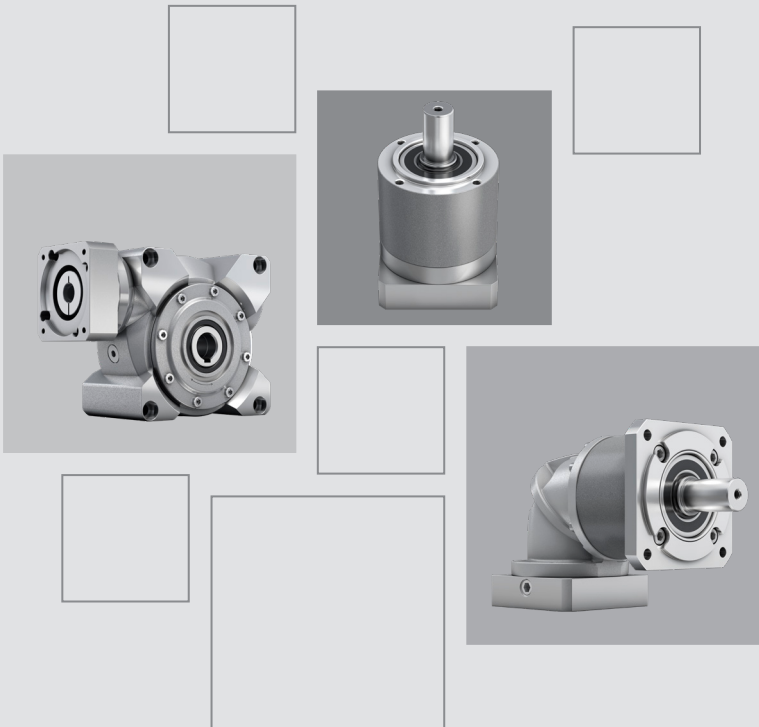

© 2024 by WITTENSTEIN alpha GmbH

All technical specifications were correct at the time of going to print. We are continually developing our products and therefore reserve the right to make modifications. This documentation is subject to occasional errors. Please appreciate that legal claims cannot be asserted as a result of incorrect specifications, illustrations or descriptions. The text, photos, technical drawings and any other illustrations printed in this publication are protected property of WITTENSTEIN alpha GmbH.

Further use of this material in printed or electronic format requires express approval from WITTENSTEIN alpha GmbH.

Any form of duplication, translation, editing, transfer to microfilm or storage on electronic systems is not permitted without express permission from WITTENSTEIN alpha GmbH.

Contents

Foreword by company management	6
WITTENSTEIN alpha	8
More than 40 years of innovation	8
Engineering Tools	12
alpha Basic Line & alpha Value Line	16
Product range and applications	16
alpha Basic Line planetary gearboxes	18
CP/CPS	18
alpha Basic Line bevel gearboxes	52
CPK/CPSK	52
alpha Basic Line worm gearboxes	86
CVH/CVS	86
alpha Value Line planetary gearboxes	104
NP/NPL/NPS/NPT/NPR/NTP	104
alpha Value Line bevel gearboxes	234
NPK/NPLK/NPSK/NPTK/NPRK	234
alpha Value Line worm gearboxes	312
NVH/NVS	312
Application-specific solutions	328
HDV	328
Product portfolio & company	338
Gearbox overview	338
Servo actuator overview	343
Value Linear Systems	346
premo – Servo actuators	347
Digital product feature - cynapse®	348
Accessories	350
Services	354
WITTENSTEIN Group	358
Information	360
Sizing – Planetary/Bevel gearboxes	360
Sizing – Worm gearboxes	364
Glossary	366
Ordering code	374

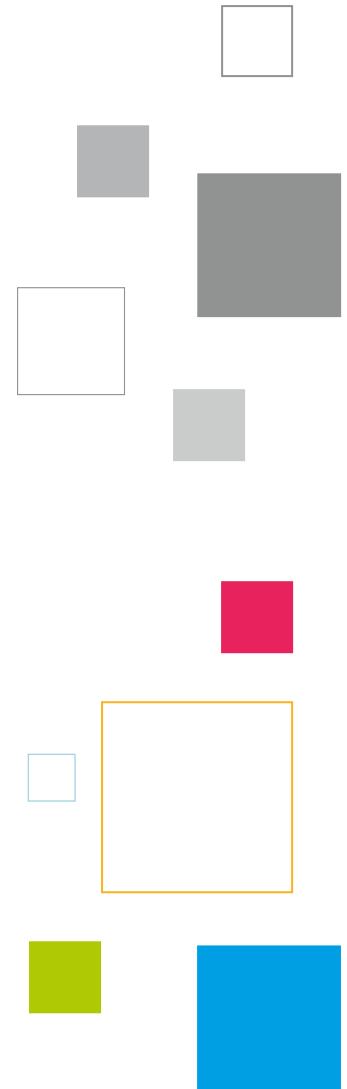



Dear Business Associates,

Even though we are extremely passionate about technology and innovation, the success of our customers is our top priority. We have designed our products and services to help you achieve a competitive advantage – through consistently high quality, permanent availability, and the best service worldwide.

To ensure that you will find the right solution at WITTENSTEIN for your specific requirements, we have tailored our range of services to the needs of many different markets. Thus our series from “Basic” to “Premium” today cover a wide product range. Gearboxes of the alpha Basic and alpha Value Line are especially suitable for applications requiring cost-oriented yet efficient solutions. Both series are specially designed for axes with medium requirements for precision, dynamics, and power density, and precisely deliver the familiar alpha quality in this domain. They offer a unique modularity in this market segment. Thanks to additional output versions in combination with the angle sections provided by our portfolio, the alpha Basic and alpha Value Line provide every possible freedom when designing different applications.

Whatever solution you need, you are sure to reach your goal quickly and easily with us. Because we offer integrated mechanical and mechatronic drive solutions for all types of axis. On demand we also provide complete solutions from a single source – complete systems including servo actuators – also for linear systems. Our product range has grown significantly again, and yet we are continuing to develop new ideas to make your work easier.

Take our word for it!

Yours

Thomas Patzak und Norbert Pastoors
Managing Directors WITTENSTEIN alpha GmbH

YOUR WORLD IS OUR DRIVE. FOR MORE THAN 40 YEARS.



SP



LP



Linear systems



TPM+

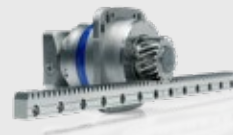

High Performance Linear System



alpha Value Line

1983

1994

1996

1999

2002

2004

2006

2007

2011

2013

2015

TP



cymex®
sizing software



XP+ / TP+ / SP+ / LP+



TPK+ / SPK+ /
HG+ / SK+ / TK+



HDV
Hygienic Design



PERFORMANCE

Performance where it counts:
High torque, outstanding precision and high power density – essential for our products and systems.

FUTURE PROOF

We live processes:
Only those who know the exact details of customer processes and requirements are in a position to develop solutions that offer added value in the short and long term.

SCALABILITY

You never make compromises:
Whatever the performance area – we offer solutions that grow with your requirements.



WITTENSTEIN

alpha

It is good to know today what will be needed tomorrow. Applying it in practice is even better. We develop technology that shapes the future –
ENGINEERING FUTURE SOLUTIONS.

EFFICIENCY

We like it „lean“:
We offer products and systems that are energy-efficient and require minimal installation space in machines.

AVAILABILITY

You need reliability:
We have the widest range of products on the market and can implement your application „just in time“.

CONNECTIVITY

We think in terms of interfaces:
All of our systems can be integrated in a wide range of peripherals.



DP⁺ for Delta robots



INIRA[®]



alpha Linear Systems



alpha Basic Line



cynapse[®]



cymex[®] select

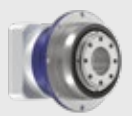

NTP

2016

cymex[®] 5



SIZING ASSISTANT



V-Drive Family



2018

premo[®]



2019

CAD POINT



2022

WITTENSTEIN Service Portal



2023

axenia value



WITTENSTEIN alpha in all axes

Complete drive solutions under one roof

We offer the best solutions for almost every application. In addition to gearboxes, our product portfolio includes a wide range of drive solutions with linear systems and servo actuators. Adapted accessories such as couplings and shrink discs round off the product portfolio.

Our products are divided into the Basic, Value, Advanced and Premium Segments in terms of “Performance” and “Value”. We want to make it even easier for our customers to find the right solution from our large portfolio for each specific application.

Overview of our product portfolio:

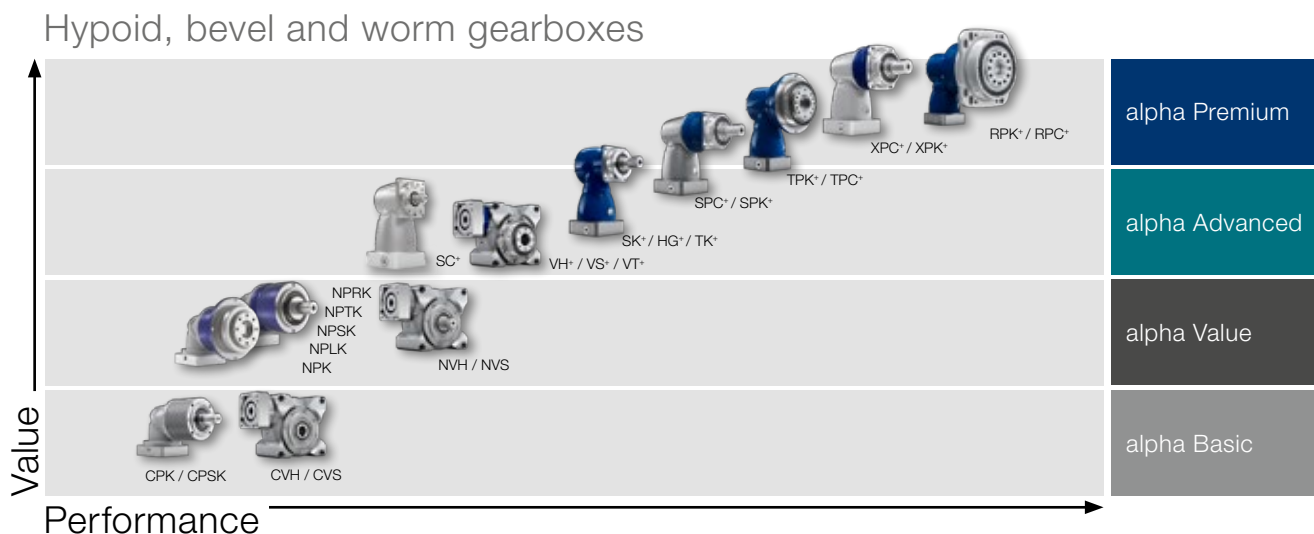
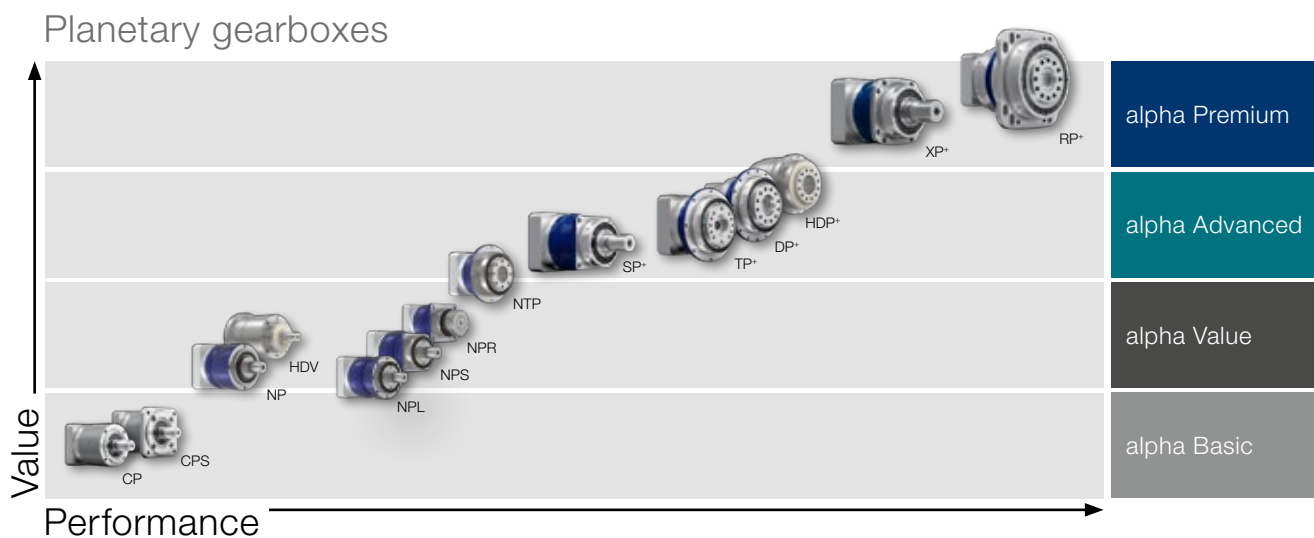

Know-how in every sector

Our solutions range from high-precision axes in manufacturing systems to packaging machines that must operate with maximum productivity in the smallest installation space.

Overview:

- Machine tools and production technology
- Food and packaging machines
- Wood working machinery
- Printing and paper machines
- Robotics and automation

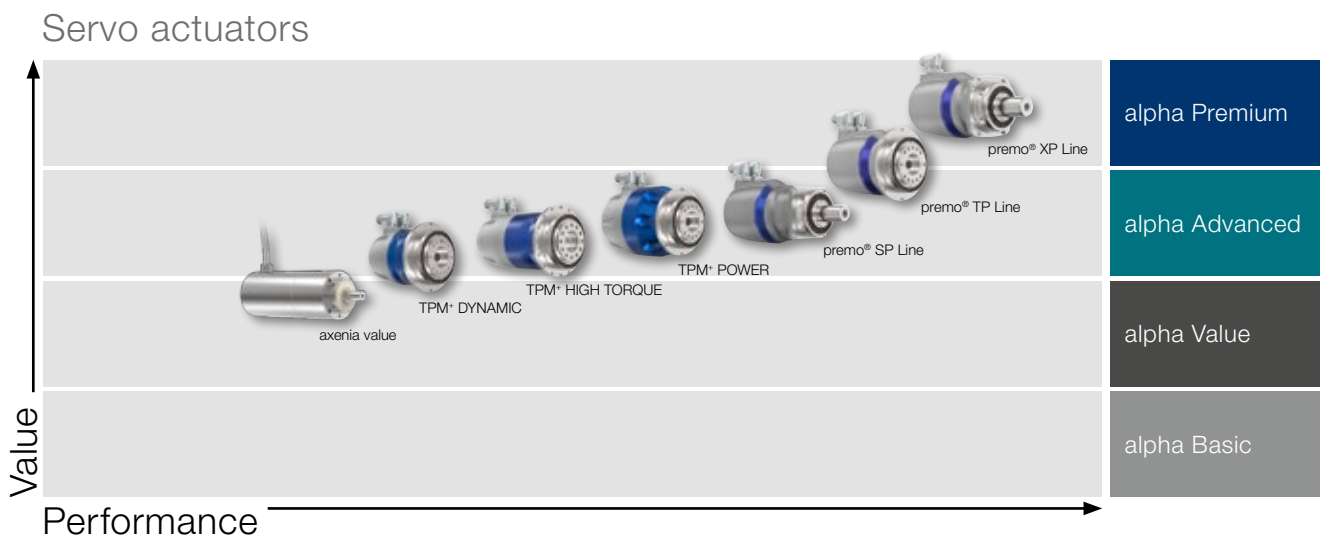
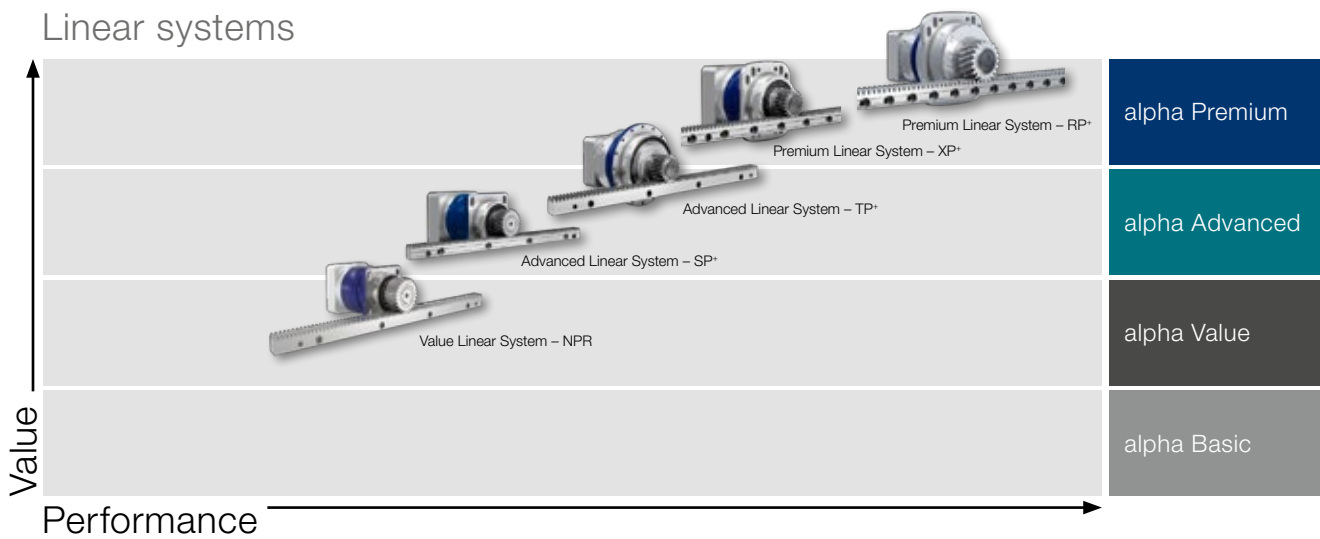

WITTENSTEIN alpha

Sizing Tools



Many ways to reach your goals

Our software portfolio helps you choose the optimal drive

You can conveniently download dimension sheets and CAD data, select the best gearbox quickly and easily design complex kinematic sequences in detail – our software solutions offer various methods of selecting the best, most reliable drive on all axes.



CAD POINT

– Your Smart Catalog

- Performance data, dimension sheets and CAD data for all types of gearboxes
- Available online without logging in
- Comprehensive documentation of the selection

www.wittenstein-cad-point.com

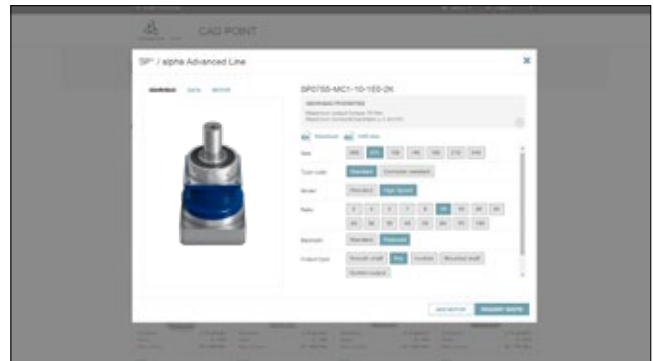

cymex® select

– Best solution within seconds

- Efficient and customizable product selection in seconds
- Top three product recommendations for your requirements
- Available online without login
- Possibility of requesting quotation quickly and directly

cymex-select.wittenstein-group.com

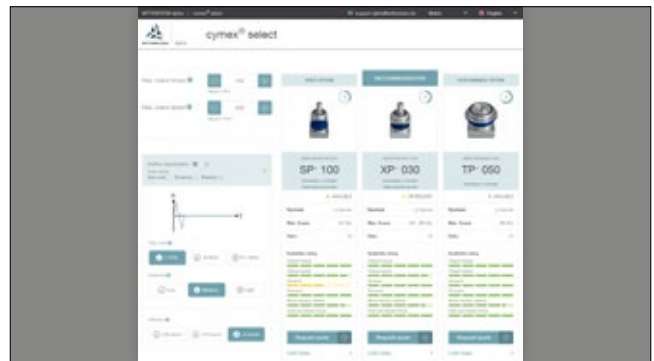

cymex®5

– Calculate on the Best

- Detailed calculation of complete drive trains
- Precise simulation of motion and load variables
- Downloadable software for complex designs

www.wittenstein-cymex.com



cymex[®] select The right drive solution in seconds

Do you want to find the optimal drive solution quickly and easily? cymex[®] select carries out technical evaluation for your application and your motor for you. The online tool presents you with a top recommendation from among 50,000 products based on 15 technical parameters and the price. You also get a performance option and a price option.

Available in 11 languages

The web-based app cymex[®] select is available online without login.



cymex-select.wittenstein-group.com

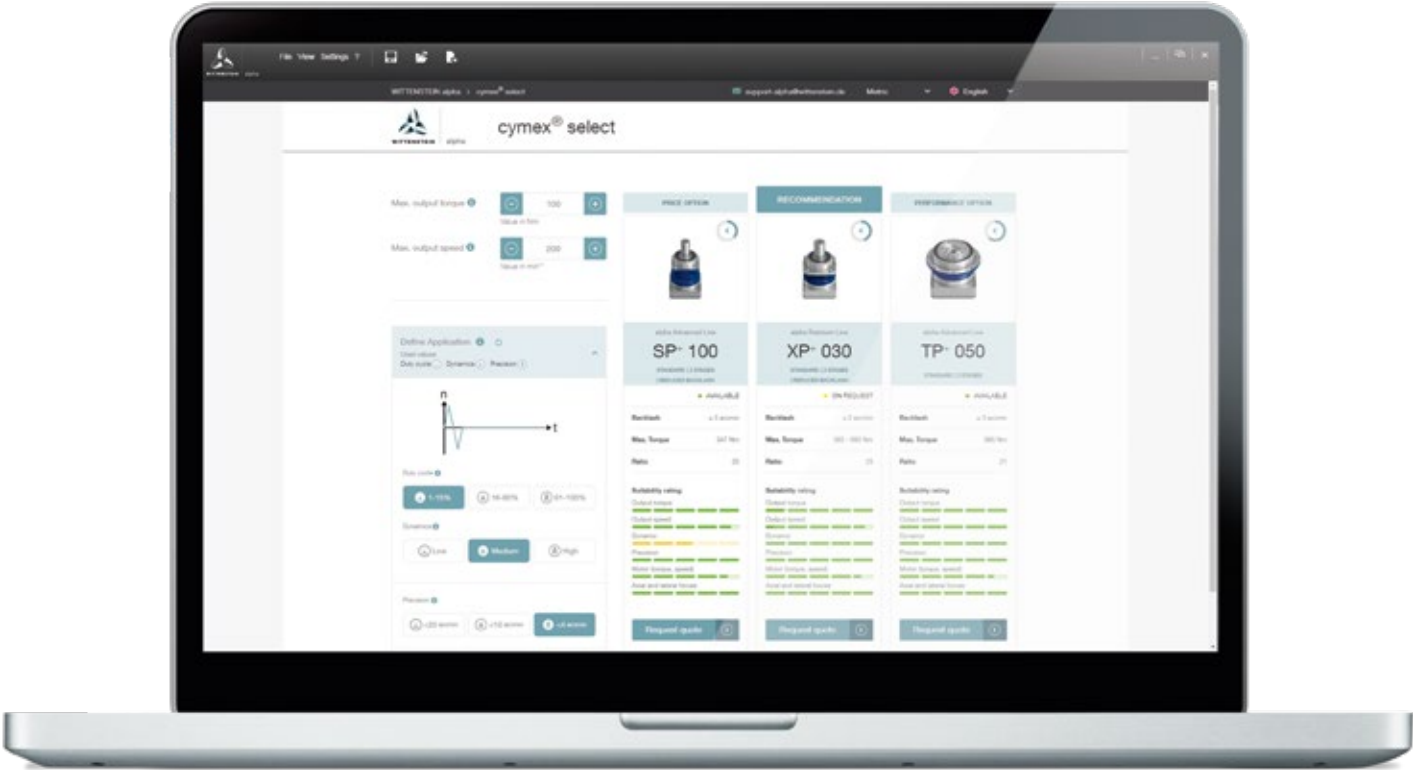

cymex[®] select

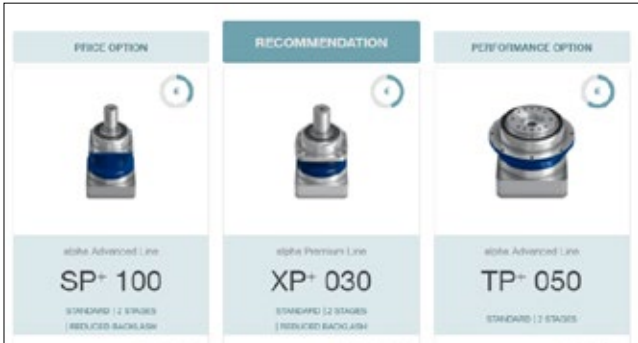

Simply find the best solution online

cymex® select offers you individual product suggestions based on technical suitability and economic evaluation as a ready-to-use ordering code. You quickly and reliably get an individual solution on the basis of three product suggestions within seconds and with no prior product know-how required.

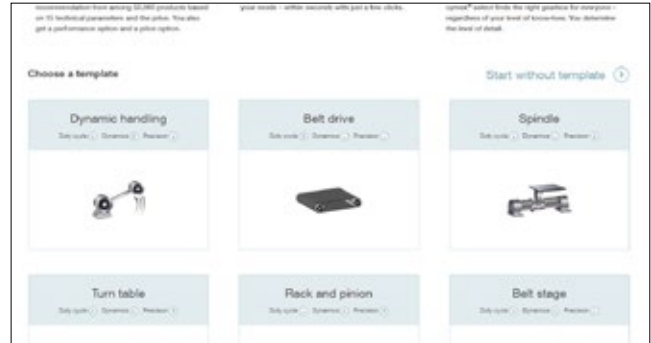

For every stage of development and every level of detail

cymex® select makes it possible for every user to select the right product in an individual manner: The degree of detail in the inputs can be adjusted as required. Starting with torque and speed, parameters such as application, the motor, external forces, drive geometries and much more can be taken into consideration. As an additional option, you have the possibility of using our application templates as a simple starting point.

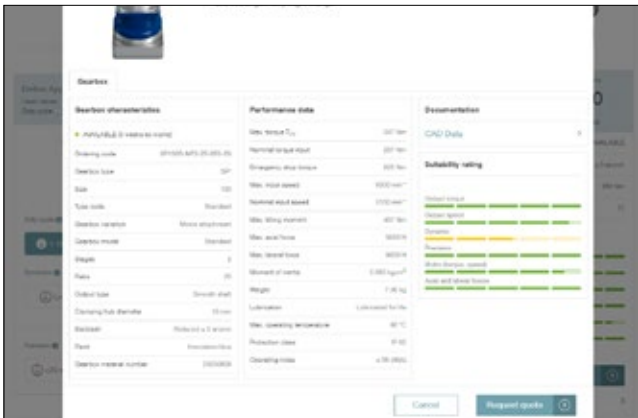

Product details at a glance

The "Detail" button opens a window containing detailed information about gearbox properties, performance data, and motor mounting parts. CAD data can also be retrieved. A direct request for a quotation is possible after a product has been selected online.

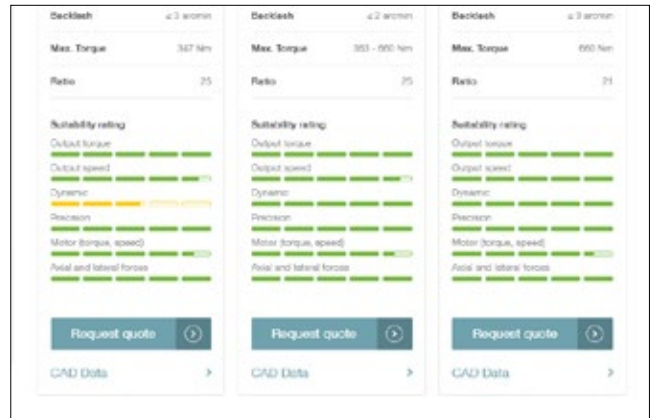

Perfect match for your requirements

cymex® select takes more than 15 technical parameters into consideration. For best results, the calculation logic is inspired by the best-in-class cymex® 5 sizing software. In addition to common parameters such as utilization of torques and speeds, factors such as rigidity, moment of inertia and controllability are also taken into account. The results are transparently displayed using a suitability rating. With background information about utilization, suitability ranges and assumptions, you can access more detailed information at any time.

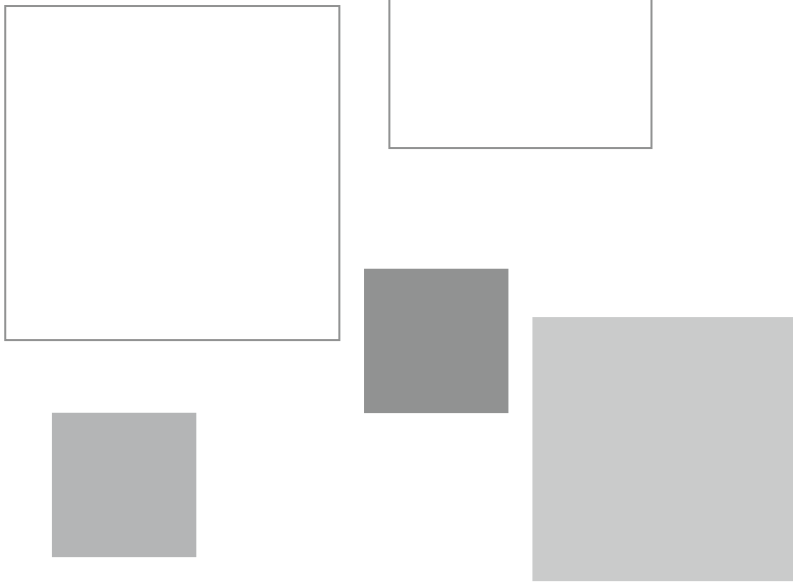

alpha Basic Line

Geared up to Fit

The gearboxes of the alpha Basic Line live up to the motto “Geared up to Fit”. The CP, CPS, CPK, and CPSK planetary and bevel gearboxes as well as the CVS and CVH worm gearboxes combine high flexibility on the drive side with optimum economy. In conjunction with backlash less than or equal to 12 arcmin, the gearboxes are the perfect choice in machines with medium to low requirements for positioning accuracy.

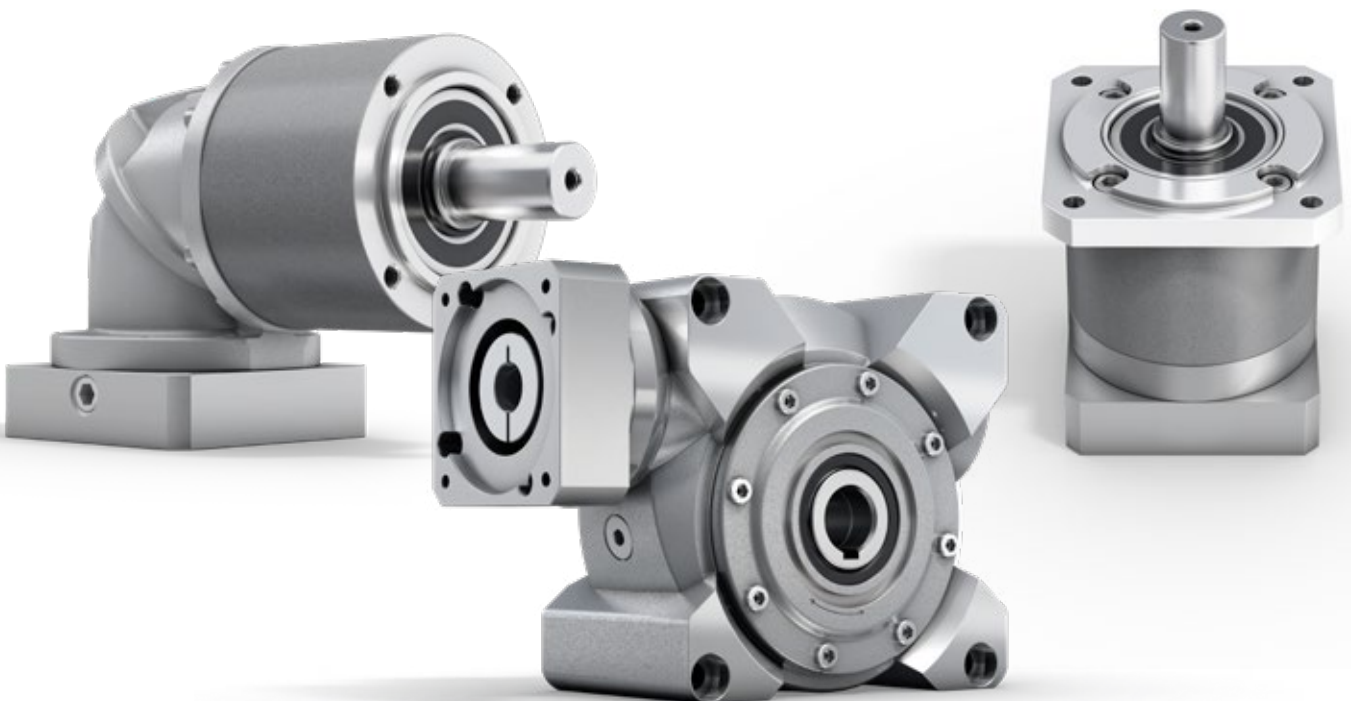



alpha Value Line

Individual Talents

The alpha Value Line impresses with economical and flexible solutions with backlash less than or equal to 8 arcmin. For example, the planetary and bevel gearboxes of the NP and NPK series as well as the NVS and NVH worm gearboxes are suitable for a wide range of applications thanks to numerous ratios and output versions – our “Individual Talents” give you new design freedom!



alpha Basic Line

PLANETARY GEARBOXES CP / CPS

The planetary gearboxes of the alpha Basic Line are the ideal choice for cost-oriented solutions. These gearboxes further increase design freedom in machines due to new additional output variants as well as five different sizes.

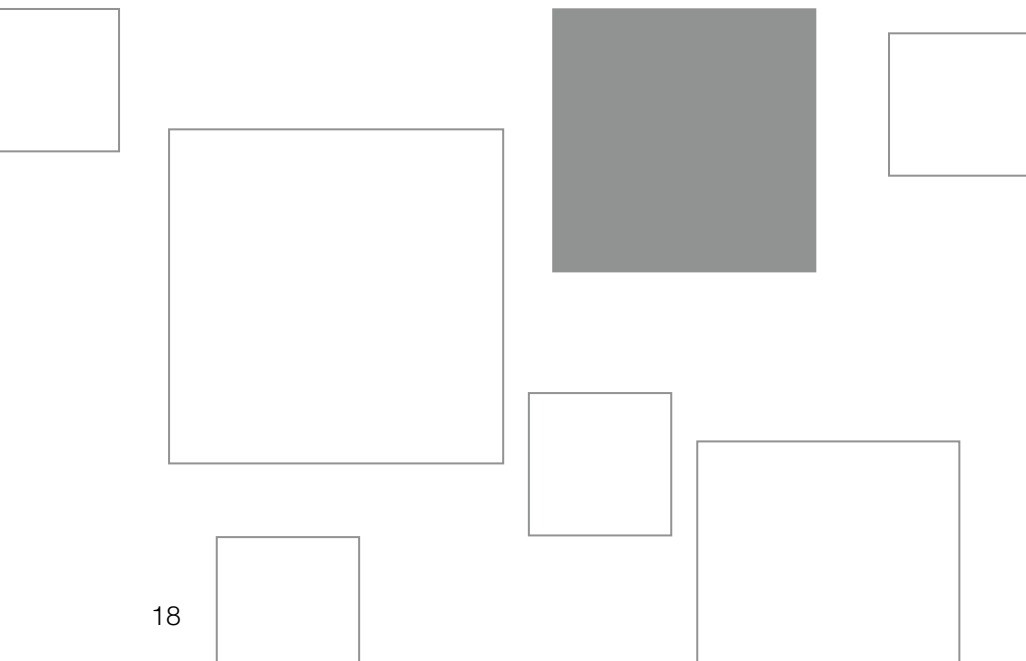



* CPS with replaceable B5 output flange

CP / CPS – Geared up to Fit



PRODUCT HIGHLIGHTS

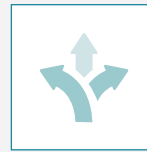

High flexibility

Different output variants offer design freedom tailored to individual requirements. The flexibility on the input side also enables the realization of different motor mounting versions.



Maximum economy

The gearboxes of the alpha Basic Line are extremely economical to purchase and highly efficient in operation.



Fast sizing

Efficient and innovative online sizing within seconds in cymex® select based on technical and economic suitability.

Tailored to applications in the mid-range and economy segment with low to medium requirements for positioning accuracy, the CP and CPS planetary gearboxes do not fail to impress. The key benefits offered by the gearboxes are high flexibility combined with maximum efficiency.



CPS – planetary gearbox with replaceable B5 output flange



CPS – planetary gearbox with long centering

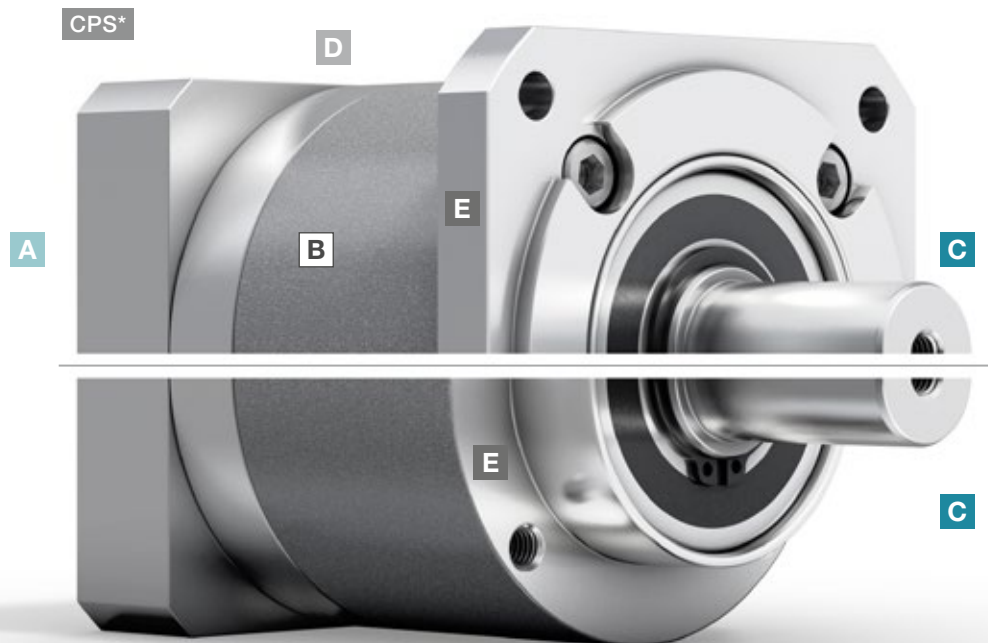

CPS

* CPS with replaceable B5 output flange

- A Flexible motor connection**
- Mounting of all common servo motors by means of a flexible and screw-fastened adapter plate
 - Large number of motor shaft diameters connectable
- D Variety of sizes**
- CP available in five different sizes (005 – 045)
 - CPS available in three different sizes (015 – 035)

- B High ratio variation**
- Large number of ratios ($i=3$ to $i=100$)
 - Available in the common binary ratios
- E Variable application connection**
- Reduced installation space and maximum compactness thanks to a long centering
 - Flange attachment for B5 mounting

- C Available output types**
- Smooth shaft
 - Shaft with key



CPS – planetary gearbox with elastomer coupling



cymex® select
BEST SOLUTION WITHIN SECONDS

Efficient gearbox sizing within seconds – online without login
cymex-select.wittenstein-group.com

CP 005 MF 1-stage

			1-stage						
Ratio	i		4	5	7	8	10		
Max. torque ^{a) b) e)}	T_{2a}	Nm	17	21	21	20	20		
		in.lb	150	186	186	177	177		
Max. acceleration torque ^{e)} (max. 1000 cycles per hour)	T_{2B}	Nm	11	14	14	13	13		
		in.lb	97	124	124	115	115		
Emergency stop torque ^{a) b) e)} (permitted 1000 times during the service life of the gearbox)	T_{2Not}	Nm	26	26	26	26	26		
		in.lb	230	230	230	230	230		
Permitted average input speed ^{d)} (at T_{2a} and 20 °C ambient temperature)	n_{1N}	rpm	3800	3800	4300	4300	4300		
Max. input speed	n_{1Max}	rpm	9000	9000	9000	9000	9000		
Mean no load running torque ^{b)} (at $n_1=3000$ rpm and 20 °C gearbox temperature)	T_{012}	Nm	0.07	0.06	0.06	0.06	0.05		
		in.lb	0.62	0.53	0.53	0.53	0.44		
Max. backlash	j_t	arcmin	≤ 12						
Torsional rigidity ^{b)}	C_{221}	Nm/arcmin	0.58	0.58	0.58	0.52	0.52		
		in.lb/arcmin	5.1	5.1	5.1	4.6	4.6		
Max. axial force ^{c)}	F_{2AMax}	N	240						
		lb _f	54						
Max. lateral force ^{c) 1)}	F_{2QMMax}	N	170						
		lb _f	38						
Max. tilting moment	M_{2KMMax}	Nm	4						
		in.lb	35						
Efficiency at full load	η	%	97						
Service life	L_n	h	> 20000						
Weight (incl. standard adapter plate)	m	kg	0.5						
		lb _m	1.1						
Operating noise (at reference ratio and reference speed – ratio-specific values available in cymex®)	L_{PA}	dB(A)	≤ 59						
Max. permitted housing temperature		°C	+90						
		°F	+194						
Ambient temperature		°C	-15 to +40						
		°F	+5 to +104						
Lubrication			Lubricated for life						
Direction of rotation			In- and output same direction						
Protection class			IP 64						
Elastomer coupling (recommended product type – validate sizing with cymex®)			ELC-0005BA010.000-X						
Bore diameter of coupling on the application side		mm	X = 004.000 - 012.700						
Mass moment of inertia (relates to the drive) Clamping hub diameter [mm]	B	11	J_1	kgcm ²	0.04	0.04	0.04	0.03	0.03
				10 ⁻³ in.lb.s ²	0.04	0.04	0.04	0.03	0.03

Please use our sizing software cymex® for a detailed sizing – www.wittenstein-cymex.com

^{a)} Valid for torque transmission only

^{b)} Valid for standard clamping hub diameter

^{c)} Refers to center of the output shaft or flange

^{d)} Please reduce input speed at higher ambient temperatures

^{e)} Valid for: Smooth shaft

¹⁾ At increased lateral forces – see glossary

Motor shaft diameter [mm]

1-stage

up to 11⁴⁾ (B)⁵⁾
clamping hub
diameter

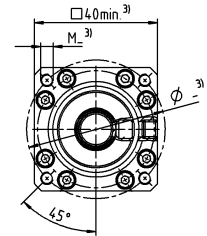
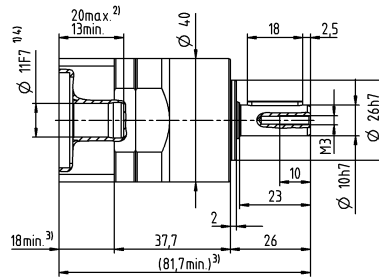
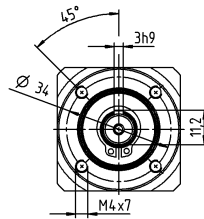

Planetary Gearboxes
Basic Line

Other output variants

Smooth shaft

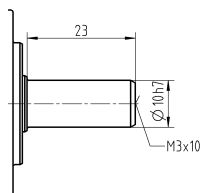

Non-tolerated dimensions are nominal dimensions

¹⁾ Check motor shaft fit

²⁾ Min. / Max. permissible motor shaft length

Longer motor shafts are possible, please contact alpha

³⁾ The dimensions depend on the motor

⁴⁾ Smaller motor shaft diameter is compensated

by a bushing with a minimum wall thickness of 1 mm

⁵⁾ Standard clamping hub diameter

CP 005 MF 2-stage

			2-stage									
Ratio	i		16	20	25	28	35	40	50	70	100	
Max. torque ^{a) b) e)}	T_{2a}	Nm	17	17	21	17	21	17	21	21	20	
		in.lb	150	150	186	150	186	150	186	186	177	
Max. acceleration torque ^{b)} (max. 1000 cycles per hour)	T_{2B}	Nm	11	11	14	11	14	11	14	14	13	
		in.lb	97	97	124	97	124	97	124	124	115	
Emergency stop torque ^{a) b) e)} (permitted 1000 times during the service life of the gearbox)	T_{2Not}	Nm	26	26	26	26	26	26	26	26	26	
		in.lb	230	230	230	230	230	230	230	230	230	
Permitted average input speed ^{d)} (at T_{2a} and 20 °C ambient temperature)	n_{1N}	rpm	3800	3800	3800	3800	4300	4300	4300	4300	4300	
Max. input speed	n_{1Max}	rpm	9000	9000	9000	9000	9000	9000	9000	9000	9000	
Mean no load running torque ^{b)} (at $n_1=3000$ rpm and 20 °C gearbox temperature)	T_{012}	Nm	0.09	0.08	0.08	0.08	0.07	0.07	0.07	0.06	0.06	
		in.lb	0.8	0.71	0.71	0.71	0.62	0.62	0.62	0.53	0.53	
Max. backlash	j_t	arcmin	≤ 18									
Torsional rigidity ^{b)}	C_{t21}	Nm/arcmin	0.58	0.58	0.58	0.58	0.58	0.58	0.58	0.58	0.52	
		in.lb/arcmin	5.1	5.1	5.1	5.1	5.1	5.1	5.1	5.1	4.6	
Max. axial force ^{c)}	F_{2AMax}	N	240									
		lb _f	54									
Max. lateral force ^{c) 9)}	F_{2OMax}	N	170									
		lb _f	38									
Max. tilting moment	M_{2KMax}	Nm	4									
		in.lb	35									
Efficiency at full load	η	%	95									
Service life	L_h	h	> 20000									
Weight (incl. standard adapter plate)	m	kg	0.7									
		lb _m	1.5									
Operating noise (at reference ratio and reference speed – ratio-specific values available in cymex®)	L_{PA}	dB(A)	≤ 59									
Max. permitted housing temperature		°C	+90									
		°F	+194									
Ambient temperature		°C	-15 to +40									
		°F	+5 to +104									
Lubrication			Lubricated for life									
Direction of rotation			In- and output same direction									
Protection class			IP 64									
Elastomer coupling (recommended product type – validate sizing with cymex®)			ELC-0005BA010.000-X									
Bore diameter of coupling on the application side		mm	X = 004.000 - 012.700									
Mass moment of inertia (relates to the drive) Clamping hub diameter [mm]	B	11	J_t	kgcm ²	0.04	0.04	0.04	0.04	0.04	0.04	0.03	0.03
				10 ⁻³ in.lb.s ²	0.04	0.04	0.04	0.04	0.04	0.04	0.04	0.03

Please use our sizing software cymex® for a detailed sizing – www.wittenstein-cymex.com

^{a)} Valid for torque transmission only

^{b)} Valid for standard clamping hub diameter

^{c)} Refers to center of the output shaft or flange

^{d)} Please reduce input speed at higher ambient temperatures

^{e)} Valid for: Smooth shaft

⁹⁾ At increased lateral forces – see glossary

Motor shaft diameter [mm]

2-stage

up to 11⁴⁾ (B)⁵⁾
clamping hub
diameter

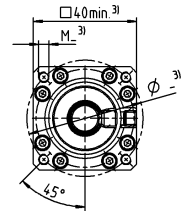
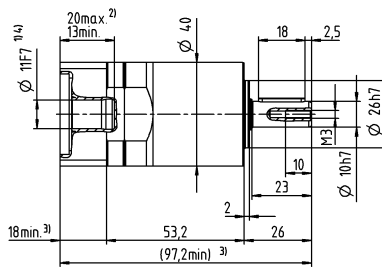
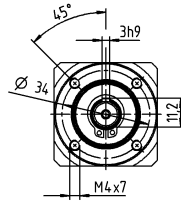

Planetary Gearboxes
Basic Line

Other output variants

Smooth shaft

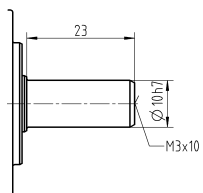

Non-tolerated dimensions are nominal dimensions

¹⁾ Check motor shaft fit

²⁾ Min. / Max. permissible motor shaft length

Longer motor shafts are possible, please contact alpha

³⁾ The dimensions depend on the motor

⁴⁾ Smaller motor shaft diameter is compensated

by a bushing with a minimum wall thickness of 1 mm

⁵⁾ Standard clamping hub diameter

CP 015 MF 1-stage

			1-stage							
Ratio	i		3	4	5	7	8	10		
Max. torque ^{a) b) e)}	T_{2a}	Nm	48	56	58	58	56	56		
		in.lb	425	496	513	513	496	496		
Max. acceleration torque ^{b)} (max. 1000 cycles per hour)	T_{2B}	Nm	30	35	40	40	35	35		
		in.lb	266	310	354	354	310	310		
Emergency stop torque ^{a) b) e)} (permitted 1000 times during the service life of the gearbox)	T_{2Not}	Nm	75	75	75	75	75	75		
		in.lb	664	664	664	664	664	664		
Permitted average input speed ^{d)} (at T_{2a} and 20 °C ambient temperature)	n_{1N}	rpm	3300	3300	3300	4000	4000	4000		
Max. input speed	n_{1Max}	rpm	7000	7000	7000	7000	7000	7000		
Mean no load running torque ^{b)} (at $n_1=3000$ rpm and 20 °C gearbox temperature)	T_{012}	Nm	0.25	0.2	0.17	0.15	0.14	0.13		
		in.lb	2.2	1.8	1.5	1.3	1.2	1.2		
Max. backlash	j_t	arcmin	≤ 12							
Torsional rigidity ^{b)}	C_{t21}	Nm/arcmin	2.1	2.1	2.1	2.1	1.9	1.9		
		in.lb/arcmin	19	19	19	19	17	17		
Max. axial force ^{c)}	F_{2AMax}	N	750							
		lb _f	169							
Max. lateral force ^{c) 1)}	F_{2OMax}	N	500							
		lb _f	113							
Max. tilting moment	M_{2KMMax}	Nm	17							
		in.lb	150							
Efficiency at full load	η	%	97							
Service life	L_h	h	> 20000							
Weight (incl. standard adapter plate)	m	kg	1.4							
		lb _m	3.1							
Operating noise (at reference ratio and reference speed – ratio-specific values available in cymex®)	L_{PA}	dB(A)	≤ 60							
Max. permitted housing temperature		°C	+90							
		°F	+194							
Ambient temperature		°C	-15 to +40							
		°F	+5 to +104							
Lubrication			Lubricated for life							
Direction of rotation			In- and output same direction							
Protection class			IP 64							
Elastomer coupling (recommended product type – validate sizing with cymex®)			ELC-0020BA014.000-X							
Bore diameter of coupling on the application side		mm	X = 008.000 - 025.000							
Mass moment of inertia (relates to the drive) Clamping hub diameter [mm]	C	14	J_1	kgcm ²	0.23	0.2	0.18	0.15	0.15	0.15
				10 ⁻³ in.lb.s ²	0.2	0.18	0.16	0.13	0.13	0.13
	E	19	J_1	kgcm ²	0.43	0.4	0.39	0.38	0.38	0.37
				10 ⁻³ in.lb.s ²	0.38	0.35	0.35	0.34	0.34	0.33

Please use our sizing software cymex® for a detailed sizing – www.wittenstein-cymex.com

^{a)} Valid for torque transmission only

^{b)} Valid for standard clamping hub diameter

^{c)} Refers to center of the output shaft or flange

^{d)} Please reduce input speed at higher ambient temperatures

^{e)} Valid for: Smooth shaft

¹⁾ At increased lateral forces – see glossary

1-stage

up to 14⁴⁾ (C)⁵⁾
clamping hub
diameter

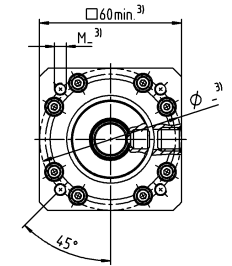
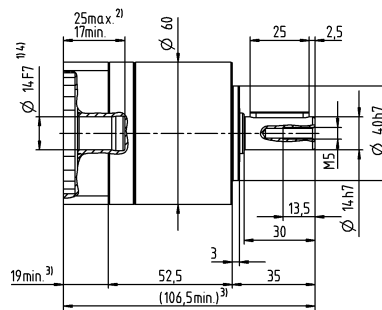
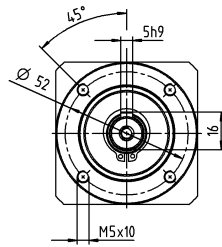

Motor shaft diameter [mm]

up to 19⁴⁾ (E)
clamping hub
diameter

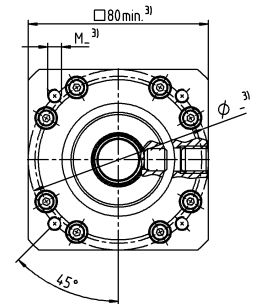
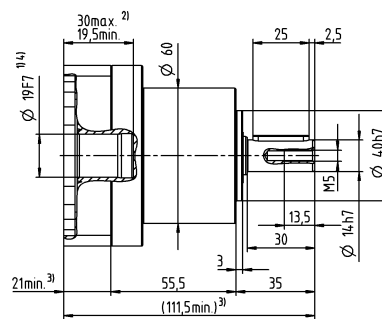
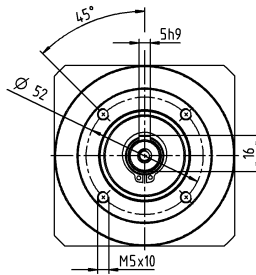

Planetary Gearboxes
Basic Line

Other output variants

Smooth shaft

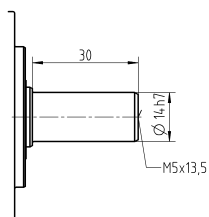

Non-tolerated dimensions are nominal dimensions

¹⁾ Check motor shaft fit

²⁾ Min. / Max. permissible motor shaft length

Longer motor shafts are possible, please contact alpha

³⁾ The dimensions depend on the motor

⁴⁾ Smaller motor shaft diameter is compensated by a bushing with a minimum wall thickness of 1 mm

⁵⁾ Standard clamping hub diameter

CP 015 MF 2-stage

			2-stage														
Ratio	i		9	12	15	16	20	25	28	30	35	40	50	70	100		
Max. torque ^{a) b) e)}	T_{2a}	Nm	48	48	48	56	56	58	56	48	58	56	58	58	56		
		in.lb	425	425	425	496	496	513	496	425	513	496	513	513	496		
Max. acceleration torque ^{b)} (max. 1000 cycles per hour)	T_{2B}	Nm	30	30	30	35	35	40	35	30	40	35	40	40	35		
		in.lb	266	266	266	310	310	354	310	266	354	310	354	354	310		
Emergency stop torque ^{a) b) e)} (permitted 1000 times during the service life of the gearbox)	T_{2Not}	Nm	75	75	75	75	75	75	75	75	75	75	75	75	75		
		in.lb	664	664	664	664	664	664	664	664	664	664	664	664	664		
Permitted average input speed ^{d)} (at T_{2a} and 20 °C ambient temperature)	n_{1N}	rpm	3300	3300	3300	3300	3300	3300	3300	3300	3300	3300	3300	4000	4000		
Max. input speed	n_{1Max}	rpm	7000	7000	7000	7000	7000	7000	7000	7000	7000	7000	7000	7000	7000		
Mean no load running torque ^{b)} (at $n_1=3000$ rpm and 20 °C gearbox temperature)	T_{012}	Nm	0.33	0.28	0.26	0.25	0.22	0.21	0.2	0.21	0.18	0.17	0.16	0.15	0.14		
		in.lb	2.9	2.5	2.3	2.2	1.9	1.9	1.8	1.9	1.6	1.5	1.4	1.3	1.2		
Max. backlash	j_t	arcmin	≤ 15														
Torsional rigidity ^{b)}	C_{t21}	Nm/arcmin	2.1	2.1	2.1	2.1	2.1	2.1	2.1	2.1	2.1	2.1	2.1	2.1	1.9		
		in.lb/arcmin	19	19	19	19	19	19	19	19	19	19	19	19	17		
Max. axial force ^{c)}	F_{2AMax}	N	750														
		lb _f	169														
Max. lateral force ^{c) 9)}	F_{2OMax}	N	500														
		lb _f	113														
Max. tilting moment	M_{2KMMax}	Nm	17														
		in.lb	150														
Efficiency at full load	η	%	95														
Service life	L_h	h	> 20000														
Weight (incl. standard adapter plate)	m	kg	1.8														
		lb _m	4														
Operating noise (at reference ratio and reference speed – ratio-specific values available in cymex®)	L_{PA}	dB(A)	≤ 60														
Max. permitted housing temperature		°C	+90														
		°F	+194														
Ambient temperature		°C	-15 to +40														
		°F	+5 to +104														
Lubrication			Lubricated for life														
Direction of rotation			In- and output same direction														
Protection class			IP 64														
Elastomer coupling (recommended product type – validate sizing with cymex®) Bore diameter of coupling on the application side			ELC-0020BA014.000-X														
		mm	X = 008.000 - 025.000														
Mass moment of inertia (relates to the drive) Clamping hub diameter [mm]	C	14	J_1	kgcm ²	0.22	0.22	0.21	0.2	0.19	0.18	0.17	0.19	0.16	0.17	0.16	0.15	0.15
				10 ⁻³ in.lb.s ²	0.19	0.19	0.19	0.18	0.17	0.16	0.17	0.14	0.15	0.14	0.13	0.13	
	E	19	J_1	kgcm ²	0.43	0.42	0.42	0.4	0.4	0.39	0.39	0.41	0.39	0.39	0.38	0.38	0.37
				10 ⁻³ in.lb.s ²	0.38	0.37	0.37	0.35	0.35	0.35	0.35	0.36	0.35	0.35	0.34	0.34	0.33

Please use our sizing software cymex® for a detailed sizing – www.wittenstein-cymex.com

^{a)} Valid for torque transmission only

^{b)} Valid for standard clamping hub diameter

^{c)} Refers to center of the output shaft or flange

^{d)} Please reduce input speed at higher ambient temperatures

^{e)} Valid for: Smooth shaft

⁹⁾ At increased lateral forces – see glossary

2-stage

up to 14⁴⁾ (C)⁵⁾
clamping hub
diameter

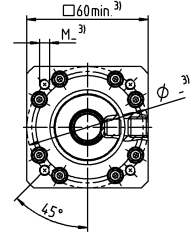
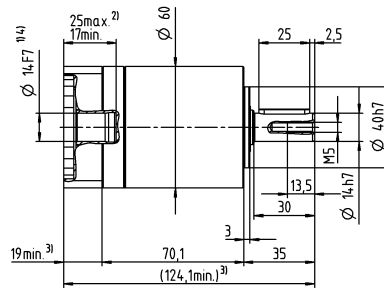
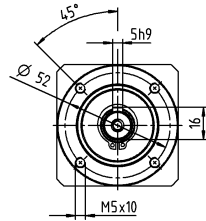

Motor shaft diameter [mm]

up to 19⁴⁾ (E)
clamping hub
diameter

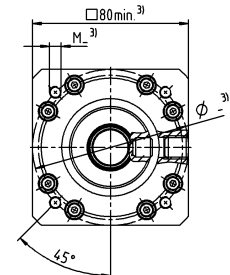
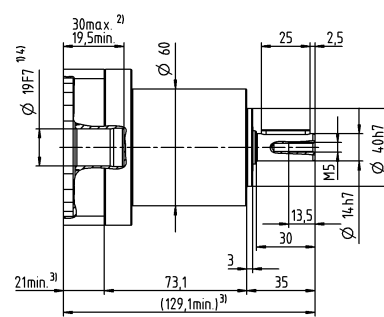
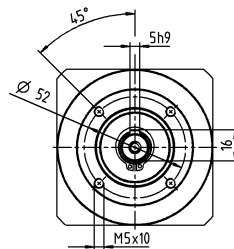

Other output variants

Smooth shaft

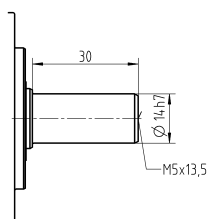

Non-tolerated dimensions are nominal dimensions

¹⁾ Check motor shaft fit

²⁾ Min. / Max. permissible motor shaft length

Longer motor shafts are possible, please contact alpha

³⁾ The dimensions depend on the motor

⁴⁾ Smaller motor shaft diameter is compensated by a bushing with a minimum wall thickness of 1 mm

⁵⁾ Standard clamping hub diameter

CP 025 MF 1-stage

			1-stage							
Ratio	i		3	4	5	7	8	10		
Max. torque ^{a) b) e)}	T_{2a}	Nm	112	150	150	150	144	144		
		in.lb	991	1328	1328	1328	1275	1275		
Max. acceleration torque ^{b)} (max. 1000 cycles per hour)	T_{2B}	Nm	70	95	100	100	90	90		
		in.lb	620	841	885	885	797	797		
Emergency stop torque ^{a) b) e)} (permitted 1000 times during the service life of the gearbox)	T_{2Not}	Nm	114	152	187	187	187	187		
		in.lb	1009	1345	1655	1655	1655	1655		
Permitted average input speed ^{d)} (at T_{2a} and 20 °C ambient temperature)	n_{1N}	rpm	3100	3100	3100	3600	3600	3600		
Max. input speed	n_{1Max}	rpm	7000	7000	7000	7000	7000	7000		
Mean no load running torque ^{b)} (at $n_1=3000$ rpm and 20 °C gearbox temperature)	T_{012}	Nm	0.38	0.3	0.26	0.23	0.21	0.19		
		in.lb	3.4	2.7	2.3	2	1.9	1.7		
Max. backlash	j_t	arcmin	≤ 12							
Torsional rigidity ^{b)}	C_{t21}	Nm/arcmin	6.1	6.1	6.1	6.1	5.5	5.5		
		in.lb/arcmin	54	54	54	54	49	49		
Max. axial force ^{c)}	F_{2AMax}	N	1600							
		lb _f	360							
Max. lateral force ^{c)}	F_{2OMax}	N	1200							
		lb _f	270							
Max. tilting moment	M_{2KMMax}	Nm	54							
		in.lb	478							
Efficiency at full load	η	%	97							
Service life	L_h	h	> 20000							
Weight (incl. standard adapter plate)	m	kg	2.9							
		lb _m	6.4							
Operating noise (at reference ratio and reference speed – ratio-specific values available in cymex®)	L_{PA}	dB(A)	≤ 62							
Max. permitted housing temperature		°C	+90							
		°F	+194							
Ambient temperature		°C	-15 to +40							
		°F	+5 to +104							
Lubrication			Lubricated for life							
Direction of rotation			In- and output same direction							
Protection class			IP 64							
Elastomer coupling (recommended product type – validate sizing with cymex®)			ELC-0060BA020.000-X							
Bore diameter of coupling on the application side		mm	X = 012.000 - 032.000							
Mass moment of inertia (relates to the drive) Clamping hub diameter [mm]	E	19	J_1	kgcm ²	0.66	0.53	0.48	0.43	0.41	0.4
				10 ⁻³ in.lb.s ²	0.58	0.47	0.42	0.38	0.36	0.35
	G	24	J_1	kgcm ²	1.5	1.4	1.3	1.3	1.3	1.3
				10 ⁻³ in.lb.s ²	1.3	1.2	1.2	1.2	1.2	1.2

Please use our sizing software cymex® for a detailed sizing – www.wittenstein-cymex.com

^{a)} Valid for torque transmission only

^{b)} Valid for standard clamping hub diameter

^{c)} Refers to center of the output shaft or flange

^{d)} Please reduce input speed at higher ambient temperatures

^{e)} Valid for: Smooth shaft

1-stage

up to 19⁴⁾ (E)⁵⁾
clamping hub
diameter

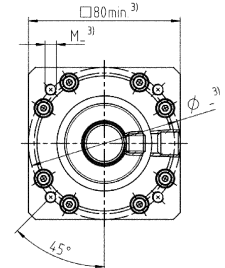
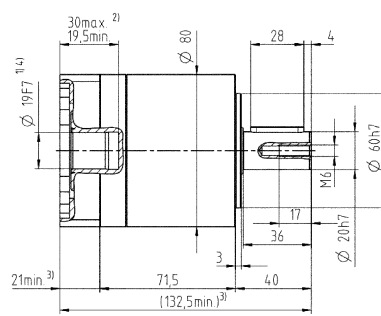
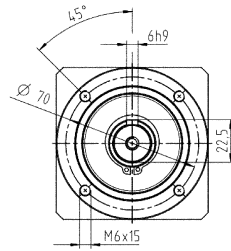

Motor shaft diameter [mm]

up to 24⁴⁾ (G)
clamping hub
diameter

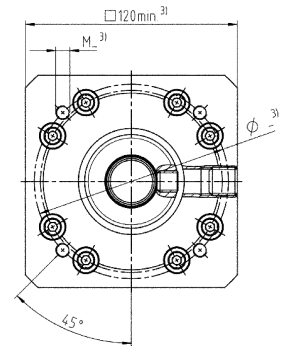
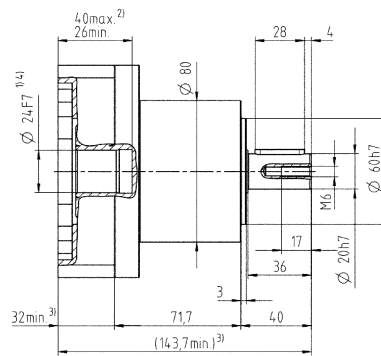
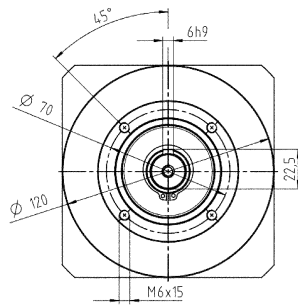

Other output variants

Smooth shaft

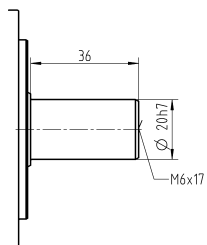

Non-tolerated dimensions are nominal dimensions

¹⁾ Check motor shaft fit

²⁾ Min. / Max. permissible motor shaft length

Longer motor shafts are possible, please contact alpha

³⁾ The dimensions depend on the motor

⁴⁾ Smaller motor shaft diameter is compensated by a bushing with a minimum wall thickness of 1 mm

⁵⁾ Standard clamping hub diameter

CP 025 MF 2-stage

			2-stage														
Ratio	i		9	12	15	16	20	25	28	30	35	40	50	70	100		
Max. torque ^{a) b) e)}	T_{2a}	Nm	112	112	112	150	150	150	150	112	150	150	150	150	144		
		in.lb	991	991	991	1328	1328	1328	1328	991	1328	1328	1328	1328	1328	1275	
Max. acceleration torque ^{b)} (max. 1000 cycles per hour)	T_{2B}	Nm	70	70	70	95	95	95	95	70	100	95	100	100	90		
		in.lb	620	620	620	841	841	841	841	620	885	841	885	885	797		
Emergency stop torque ^{a) b) e)} (permitted 1000 times during the service life of the gearbox)	T_{2Not}	Nm	187	187	187	187	187	187	187	187	187	187	187	187	187		
		in.lb	1655	1655	1655	1655	1655	1655	1655	1655	1655	1655	1655	1655	1655		
Permitted average input speed ^{d)} (at T_{2a} and 20 °C ambient temperature)	n_{1N}	rpm	3100	3100	3100	3100	3100	3100	3100	3100	3100	3100	3100	3600	3600		
Max. input speed	n_{1Max}	rpm	7000	7000	7000	7000	7000	7000	7000	7000	7000	7000	7000	7000	7000		
Mean no load running torque ^{b)} (at $n_1=3000$ rpm and 20 °C gearbox temperature)	T_{012}	Nm	0.5	0.43	0.39	0.38	0.34	0.32	0.3	0.31	0.28	0.26	0.24	0.22	0.21		
		in.lb	4.4	3.8	3.5	3.4	3	2.8	2.7	2.7	2.5	2.3	2.1	1.9	1.9		
Max. backlash	j_t	arcmin	≤ 15														
Torsional rigidity ^{b)}	C_{121}	Nm/arcmin	6.1	6.1	6.1	6.1	6.1	6.1	6.1	6.1	6.1	6.1	6.1	6.1	5.5		
		in.lb/arcmin	54	54	54	54	54	54	54	54	54	54	54	54	49		
Max. axial force ^{c)}	F_{2AMax}	N	1600														
		lb _f	360														
Max. lateral force ^{c)}	F_{2OMax}	N	1200														
		lb _f	270														
Max. tilting moment	M_{2KMMax}	Nm	54														
		in.lb	478														
Efficiency at full load	η	%	95														
Service life	L_h	h	> 20000														
Weight (incl. standard adapter plate)	m	kg	3.7														
		lb _m	8.2														
Operating noise (at reference ratio and reference speed – ratio-specific values available in cymex®)	L_{PA}	dB(A)	≤ 62														
Max. permitted housing temperature		°C	+90														
		°F	+194														
Ambient temperature		°C	-15 to +40														
		°F	+5 to +104														
Lubrication			Lubricated for life														
Direction of rotation			In- and output same direction														
Protection class			IP 64														
Elastomer coupling (recommended product type – validate sizing with cymex®)			ELC-0060BA020.000-X														
Bore diameter of coupling on the application side		mm	X = 012.000 - 032.000														
Mass moment of inertia (relates to the drive) Clamping hub diameter [mm]	E	19	J_1	kgcm ²	0.66	1.4	1.6	0.98	1.1	0.82	1.2	2.1	0.88	1.4	1	0.71	0.54
				10 ⁻³ in.lb.s ²	0.58	1.2	1.4	0.87	0.97	0.73	1.1	1.9	0.78	1.2	0.89	0.63	0.48
	G	24	J_1	kgcm ²	1.5	2.3	2.4	1.8	1.9	1.7	2	3	1.7	2.2	1.9	1.6	1.4
				10 ⁻³ in.lb.s ²	1.3	2	2.1	1.6	1.7	1.5	1.8	2.7	1.5	1.9	1.7	1.4	1.2

Please use our sizing software cymex® for a detailed sizing – www.wittenstein-cymex.com

^{a)} Valid for torque transmission only

^{b)} Valid for standard clamping hub diameter

^{c)} Refers to center of the output shaft or flange

^{d)} Please reduce input speed at higher ambient temperatures

^{e)} Valid for: Smooth shaft

2-stage

up to 19⁴⁾ (E)⁵⁾
clamping hub
diameter

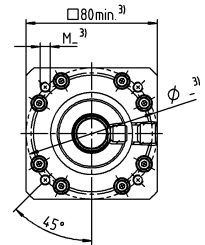
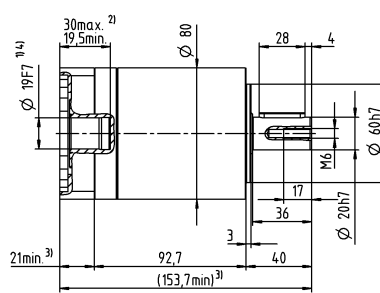
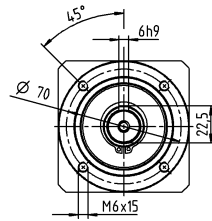

Motor shaft diameter [mm]

up to 24⁴⁾ (G)
clamping hub
diameter

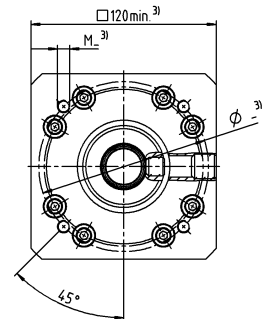
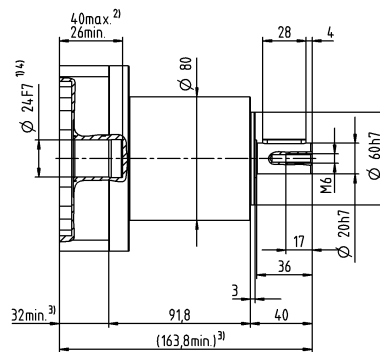
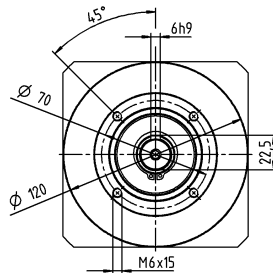

Other output variants

Smooth shaft

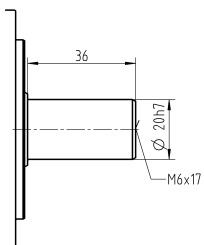

Non-tolerated dimensions are nominal dimensions

¹⁾ Check motor shaft fit

²⁾ Min. / Max. permissible motor shaft length

Longer motor shafts are possible, please contact alpha

³⁾ The dimensions depend on the motor

⁴⁾ Smaller motor shaft diameter is compensated by a bushing with a minimum wall thickness of 1 mm

⁵⁾ Standard clamping hub diameter

CP 035 MF 1-stage

			1-stage							
Ratio	i		3	4	5	7	8	10		
Max. torque ^{a) b) e)}	T_{2a}	Nm	272	272	272	272	272	272		
		in.lb	2407	2407	2407	2407	2407	2407		
Max. acceleration torque ^{b)} (max. 1000 cycles per hour)	T_{2B}	Nm	175	255	250	250	220	220		
		in.lb	1549	2257	2213	2213	1947	1947		
Emergency stop torque ^{a) b) e)} (permitted 1000 times during the service life of the gearbox)	T_{2Not}	Nm	460	480	480	480	470	480		
		in.lb	4071	4248	4248	4248	4160	4248		
Permitted average input speed ^{d)} (at T_{2a} and 20 °C ambient temperature)	n_{1N}	rpm	2300	2300	2300	2800	2800	2800		
Max. input speed	n_{1Max}	rpm	5500	5500	5500	5500	5500	5500		
Mean no load running torque ^{b)} (at $n_1=3000$ rpm and 20 °C gearbox temperature)	T_{012}	Nm	0.95	0.76	0.66	0.57	0.52	0.48		
		in.lb	8.4	6.7	5.8	5	4.6	4.2		
Max. backlash	j_t	arcmin	≤ 12							
Torsional rigidity ^{b)}	C_{t21}	Nm/arcmin	16	16	16	16	14	14		
		in.lb/arcmin	142	142	142	142	124	124		
Max. axial force ^{c)}	F_{2AMax}	N	2500							
		lb _f	563							
Max. lateral force ^{c)}	F_{2OMax}	N	1750							
		lb _f	394							
Max. tilting moment	M_{2KMMax}	Nm	98							
		in.lb	867							
Efficiency at full load	η	%	97							
Service life	L_h	h	> 20000							
Weight (incl. standard adapter plate)	m	kg	7.5							
		lb _m	17							
Operating noise (at reference ratio and reference speed – ratio-specific values available in cymex®)	L_{PA}	dB(A)	≤ 66							
Max. permitted housing temperature		°C	+90							
		°F	+194							
Ambient temperature		°C	-15 to +40							
		°F	+5 to +104							
Lubrication			Lubricated for life							
Direction of rotation			In- and output same direction							
Protection class			IP 64							
Elastomer coupling (recommended product type – validate sizing with cymex®)			ELC-0150BA025.000-X							
Bore diameter of coupling on the application side		mm	X = 019.000 - 036.000							
Mass moment of inertia (relates to the drive) Clamping hub diameter [mm]	G	24	J_1	kgcm ²	2.6	1.9	1.7	1.5	1.4	1.4
				10 ⁻³ in.lb.s ²	2.3	1.7	1.5	1.3	1.2	1.2
	K	38	J_1	kgcm ²	7.8	7.1	6.9	6.7	6.6	6.5
				10 ⁻³ in.lb.s ²	6.9	6.3	6.1	5.9	5.8	5.8

Please use our sizing software cymex® for a detailed sizing – www.wittenstein-cymex.com

^{a)} Valid for torque transmission only

^{b)} Valid for standard clamping hub diameter

^{c)} Refers to center of the output shaft or flange

^{d)} Please reduce input speed at higher ambient temperatures

^{e)} Valid for: Smooth shaft

1-stage

up to 24⁴⁾ (G)⁵⁾
clamping hub
diameter

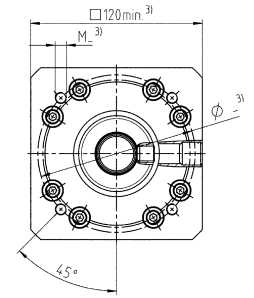
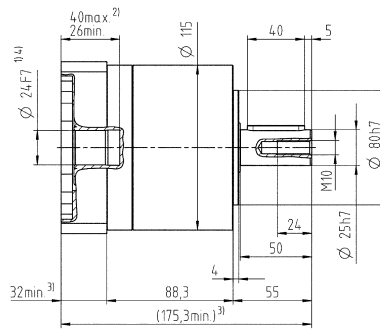
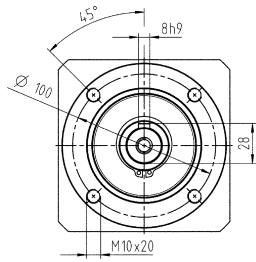

Planetary Gearboxes
Basic Line

Motor shaft diameter [mm]

up to 38⁴⁾ (K)
clamping hub
diameter

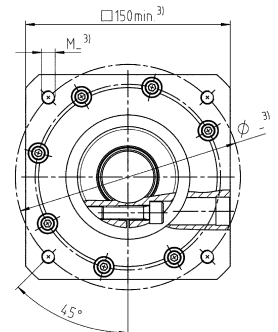
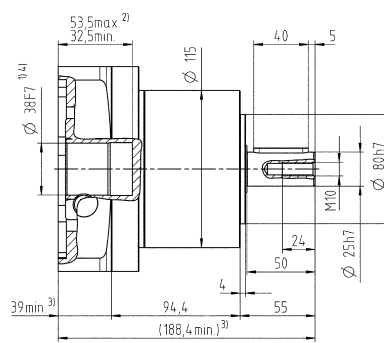
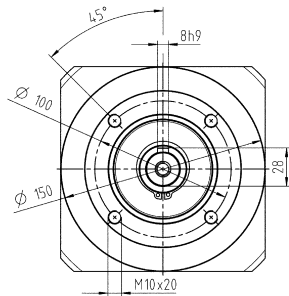

Other output variants

Smooth shaft

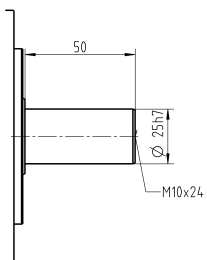

Non-tolerated dimensions are nominal dimensions

¹⁾ Check motor shaft fit

²⁾ Min. / Max. permissible motor shaft length

Longer motor shafts are possible, please contact alpha

³⁾ The dimensions depend on the motor

⁴⁾ Smaller motor shaft diameter is compensated by a bushing with a minimum wall thickness of 1 mm

⁵⁾ Standard clamping hub diameter

CP 035 MF 2-stage

			2-stage														
Ratio	i		9	12	15	16	20	25	28	30	35	40	50	70	100		
Max. torque ^{a) b) e)}	T_{2a}	Nm	272	272	272	272	272	272	272	272	272	272	272	272	272		
		in.lb	2407	2407	2407	2407	2407	2407	2407	2407	2407	2407	2407	2407	2407	2407	
Max. acceleration torque ^{b)} (max. 1000 cycles per hour)	T_{2B}	Nm	175	175	175	255	255	250	255	175	250	255	250	250	220		
		in.lb	1549	1549	1549	2257	2257	2213	2257	1549	2213	2257	2213	2213	1947		
Emergency stop torque ^{a) b) e)} (permitted 1000 times during the service life of the gearbox)	T_{2Not}	Nm	480	480	480	480	480	480	480	315	480	480	480	480	480		
		in.lb	4248	4248	4248	4248	4248	4248	4248	2788	4248	4248	4248	4248	4248		
Permitted average input speed ^{d)} (at T_{2a} and 20 °C ambient temperature)	n_{1N}	rpm	2300	2300	2300	2300	2300	2300	2300	2300	2300	2300	2300	2800	2800		
Max. input speed	n_{1Max}	rpm	5500	5500	5500	5500	5500	5500	5500	5500	5500	5500	5500	5500	5500		
Mean no load running torque ^{b)} (at $n_1=3000$ rpm and 20 °C gearbox temperature)	T_{012}	Nm	1.3	1.1	0.98	0.95	0.85	0.8	0.76	0.79	0.7	0.66	0.61	0.56	0.52		
		in.lb	12	9.7	8.7	8.4	7.5	7.1	6.7	7	6.2	5.8	5.4	5	4.6		
Max. backlash	j_t	arcmin	≤ 15														
Torsional rigidity ^{b)}	C_{t21}	Nm/arcmin	16	16	16	16	16	16	16	16	16	16	16	16	14		
		in.lb/arcmin	142	142	142	142	142	142	142	142	142	142	142	142	124		
Max. axial force ^{c)}	F_{2AMax}	N	2500														
		lb _f	563														
Max. lateral force ^{c)}	F_{2OMax}	N	1750														
		lb _f	394														
Max. tilting moment	M_{2KMMax}	Nm	98														
		in.lb	867														
Efficiency at full load	η	%	95														
Service life	L_h	h	> 20000														
Weight (incl. standard adapter plate)	m	kg	9.6														
		lb _m	21														
Operating noise (at reference ratio and reference speed – ratio-specific values available in cymex®)	L_{PA}	dB(A)	≤ 66														
Max. permitted housing temperature		°C	+90														
		°F	+194														
Ambient temperature		°C	-15 to +40														
		°F	+5 to +104														
Lubrication			Lubricated for life														
Direction of rotation			In- and output same direction														
Protection class			IP 64														
Elastomer coupling (recommended product type – validate sizing with cymex®)			ELC-0150BA025.000-X														
Bore diameter of coupling on the application side		mm	X = 019.000 - 036.000														
Mass moment of inertia (relates to the drive) Clamping hub diameter [mm]	G	24	J_1	kgcm ²	2.7	2.5	2.5	2.3	2.3	2.1	2.4	3.1	2.2	2.6	2.2	1.9	1.7
				10 ⁻³ in.lb.s ²	2.4	2.2	2.2	2	2	1.9	2.1	2.7	1.9	2.3	1.9	1.7	1.5
	K	38	J_1	kgcm ²	7.9	7.7	7.8	7.5	7.5	7.3	7.5	8.3	7.4	7.8	7.4	7.1	6.9
				10 ⁻³ in.lb.s ²	7	6.8	6.9	6.6	6.6	6.5	6.6	7.3	6.5	6.9	6.5	6.3	6.1

Please use our sizing software cymex® for a detailed sizing – www.wittenstein-cymex.com

^{a)} Valid for torque transmission only

^{b)} Valid for standard clamping hub diameter

^{c)} Refers to center of the output shaft or flange

^{d)} Please reduce input speed at higher ambient temperatures

^{e)} Valid for: Smooth shaft

2-stage

up to 24⁴⁾ (G)⁵⁾
clamping hub
diameter

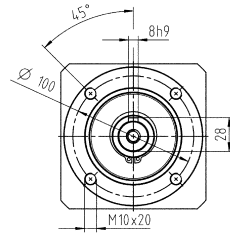

up to 38⁴⁾ (K)
clamping hub
diameter

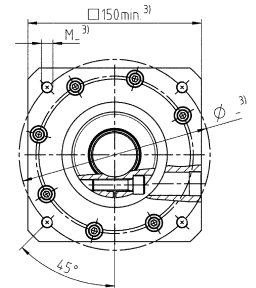
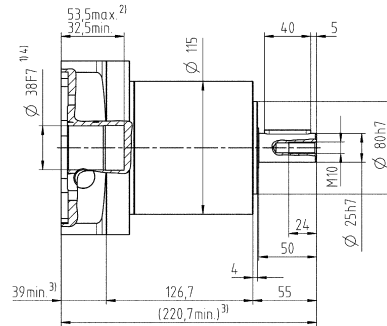
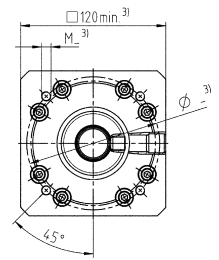
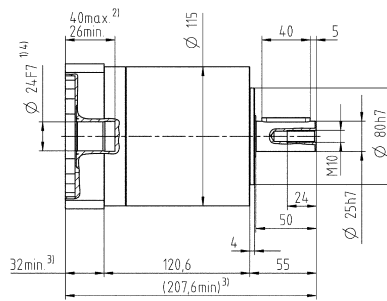
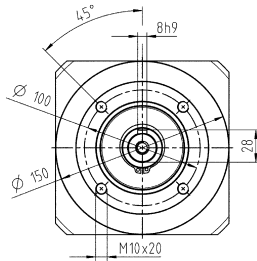

Motor shaft diameter [mm]

Planetary Gearboxes
Basic Line

Other output variants

Smooth shaft

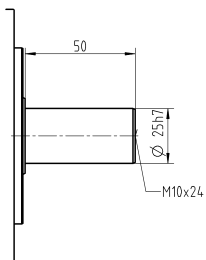

Non-tolerated dimensions are nominal dimensions

¹⁾ Check motor shaft fit

²⁾ Min. / Max. permissible motor shaft length

Longer motor shafts are possible, please contact alpha

³⁾ The dimensions depend on the motor

⁴⁾ Smaller motor shaft diameter is compensated

by a bushing with a minimum wall thickness of 1 mm

⁵⁾ Standard clamping hub diameter

CP 045 MF 1-/2-stage

			1-stage			2-stage				
Ratio	i		5	8	10	25	50	100		
Max. torque ^{a) b) e)}	T_{2a}	Nm	800	640	640	700	700	640		
		in.lb	7081	5665	5665	6196	6196	5665		
Max. acceleration torque ^{a)} (max. 1000 cycles per hour)	T_{2B}	Nm	500	400	400	500	500	400		
		in.lb	4425	3540	3540	4425	4425	3540		
Emergency stop torque ^{a) b) e)} (permitted 1000 times during the service life of the gearbox)	T_{2Not}	Nm	1000	1000	1000	1000	1000	1000		
		in.lb	8851	8851	8851	8851	8851	8851		
Permitted average input speed ^{d)} (at T_{2a} and 20 °C ambient temperature)	n_{1N}	rpm	2000	2200	2300	2600	3000	3000		
Max. input speed	n_{1Max}	rpm	4000	4000	4000	6000	6000	6000		
Mean no load running torque ^{b)} (at $n_i=3000$ rpm and 20 °C gearbox temperature)	T_{012}	Nm	2.4	2	1.9	0.8	0.6	0.55		
		in.lb	21	18	17	7.1	5.3	4.9		
Max. backlash	j_t	arcmin	≤ 12			≤ 15				
Torsional rigidity ^{b)}	C_{121}	Nm/arcmin	55	44	44	55	55	44		
		in.lb/arcmin	487	389	389	487	487	389		
Max. axial force ^{c)}	F_{2AMax}	N	6000			6000				
		lb _f								
Max. lateral force ^{c)}	F_{2OMax}	N	8000			8000				
		lb _f								
Max. tilting moment	M_{2KMax}	Nm	704			704				
		in.lb	6231			6231				
Efficiency at full load	η	%	97			95				
Service life	L_n	h	> 20000			> 20000				
Weight (incl. standard adapter plate)	m	kg	20			21				
		lb _m	44			46				
Operating noise (at reference ratio and reference speed – ratio-specific values available in cymex®)	L_{PA}	dB(A)	≤ 68			≤ 65				
Max. permitted housing temperature		°C	+90			+90				
		°F	+194			+194				
Ambient temperature		°C	-15 to +40			-15 to +40				
		°F	+5 to +104			+5 to +104				
Lubrication			Lubricated for life							
Direction of rotation			In- and output same direction							
Protection class			IP 64							
Elastomer coupling (recommended product type – validate sizing with cymex®) Bore diameter of coupling on the application side			ELC-0300BA040.000-X							
		mm	X = 020.000 - 045.000							
Mass moment of inertia (relates to the drive) Clamping hub diameter [mm]	E	19	J_1	kgcm ²	-	-	-	1.2	1.1	0.82
				10 ⁻³ in.lb.s ²	-	-	-	1,1	0,97	0,73
	G	24	J_1	kgcm ²	-	-	-	2	1,8	1,6
				10 ⁻³ in.lb.s ²	-	-	-	1,8	1,6	1,4
	H	28	J_1	kgcm ²	-	-	-	1,7	1,5	1,3
				10 ⁻³ in.lb.s ²	-	-	-	1,5	1,3	1,2
	I	32	J_1	kgcm ²	-	-	-	5,8	5,6	5,4
				10 ⁻³ in.lb.s ²	-	-	-	5,1	5	4,8
	K	38	J_1	kgcm ²	8.8	7.4	7.2	7	6,8	6,5
				10 ⁻³ in.lb.s ²	7.8	6.5	6.4	6,2	6	5,8

Please use our sizing software cymex® for a detailed sizing – www.wittenstein-cymex.com

^{a)} Valid for torque transmission only

^{b)} Valid for standard clamping hub diameter

^{c)} Refers to center of the output shaft or flange

^{d)} Please reduce input speed at higher ambient temperatures

^{e)} Valid for: Smooth shaft

1-stage

up to 38⁴⁾ (K)⁵⁾
clamping hub
diameter

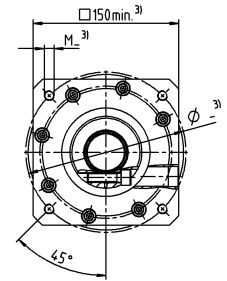
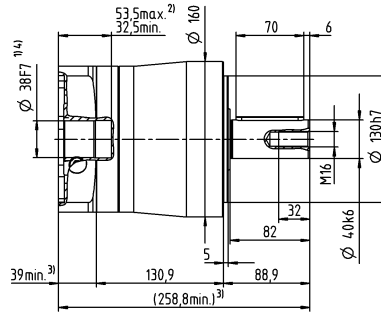
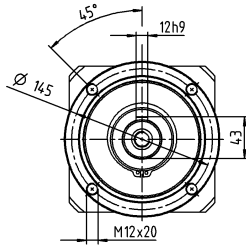

2-stage

up to 19/24/28⁴⁾
(E/G⁵⁾/H)
clamping hub
diameter

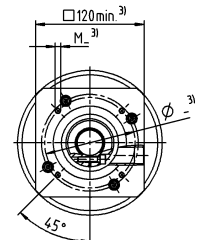
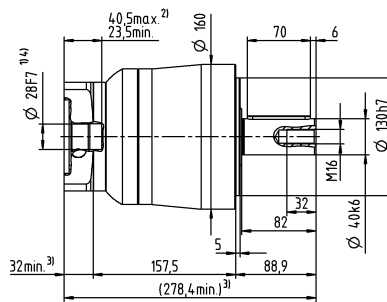
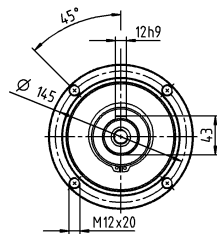

up to 32/38⁴⁾
(I/K)
clamping hub
diameter

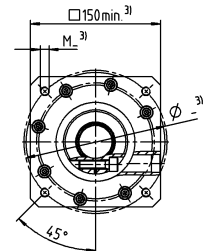
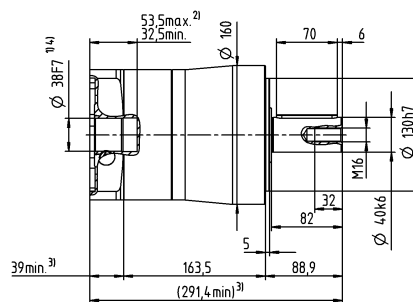
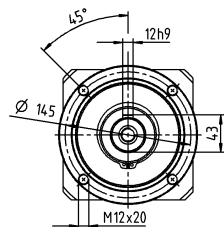

Motor shaft diameter [mm]

Other output variants

Smooth shaft

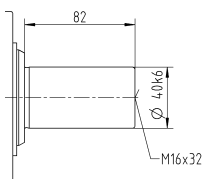

Non-tolerated dimensions are nominal dimensions

¹⁾ Check motor shaft fit

²⁾ Min. / Max. permissible motor shaft length

Longer motor shafts are possible, please contact alpha

³⁾ The dimensions depend on the motor

⁴⁾ Smaller motor shaft diameter is compensated by a bushing with a minimum wall thickness of 1 mm

⁵⁾ Standard clamping hub diameter

CPS 015 MF 1-stage

			1-stage							
Ratio	i		3	4	5	7	8	10		
Max. torque ^{a) b) e)}	T_{2a}	Nm	48	56	58	58	56	56		
		in.lb	425	496	513	513	496	496		
Max. acceleration torque ^{b)} (max. 1000 cycles per hour)	T_{2B}	Nm	30	35	40	40	35	35		
		in.lb	266	310	354	354	310	310		
Emergency stop torque ^{a) b) e)} (permitted 1000 times during the service life of the gearbox)	T_{2Not}	Nm	75	75	75	75	75	75		
		in.lb	664	664	664	664	664	664		
Permitted average input speed ^{d)} (at T_{2a} and 20 °C ambient temperature)	n_{1N}	rpm	3300	3300	3300	4000	4000	4000		
Max. input speed	n_{1Max}	rpm	7000	7000	7000	7000	7000	7000		
Mean no load running torque ^{b)} (at $n_1=3000$ rpm and 20 °C gearbox temperature)	T_{012}	Nm	0.25	0.2	0.17	0.15	0.14	0.13		
		in.lb	2.2	1.8	1.5	1.3	1.2	1.2		
Max. backlash	j_t	arcmin	≤ 12							
Torsional rigidity ^{b)}	C_{t21}	Nm/arcmin	2.1	2.1	2.1	2.1	1.9	1.9		
		in.lb/arcmin	19	19	19	19	17	17		
Max. axial force ^{c)}	F_{2AMax}	N	750							
		lb _f	169							
Max. lateral force ^{c)}	F_{2OMax}	N	500							
		lb _f	113							
Max. tilting moment	M_{2KMMax}	Nm	17							
		in.lb	150							
Efficiency at full load	η	%	97							
Service life	L_h	h	> 20000							
Weight (incl. standard adapter plate)	m	kg	1.4							
		lb _m	3.1							
Operating noise (at reference ratio and reference speed – ratio-specific values available in cymex®)	L_{PA}	dB(A)	≤ 60							
Max. permitted housing temperature		°C	+90							
		°F	+194							
Ambient temperature		°C	-15 to +40							
		°F	+5 to +104							
Lubrication			Lubricated for life							
Direction of rotation			In- and output same direction							
Protection class			IP 64							
Elastomer coupling (recommended product type – validate sizing with cymex®)			ELC-0020BA014.000-X							
Bore diameter of coupling on the application side		mm	X = 008.000 - 025.000							
Mass moment of inertia (relates to the drive) Clamping hub diameter [mm]	C	14	J_1	kgcm ²	0.23	0.2	0.18	0.15	0.15	0.15
				10 ⁻³ in.lb.s ²	0.2	0.18	0.16	0.13	0.13	0.13
	E	19	J_1	kgcm ²	0.43	0.4	0.39	0.38	0.38	0.37
				10 ⁻³ in.lb.s ²	0.38	0.35	0.35	0.34	0.34	0.33

Please use our sizing software cymex® for a detailed sizing – www.wittenstein-cymex.com

^{a)} Valid for torque transmission only

^{b)} Valid for standard clamping hub diameter

^{c)} Refers to center of the output shaft or flange

^{d)} Please reduce input speed at higher ambient temperatures

^{e)} Valid for: Smooth shaft

1-stage

up to 14⁴⁾ (C)⁵⁾
clamping hub
diameter

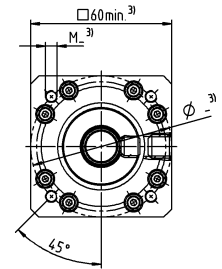
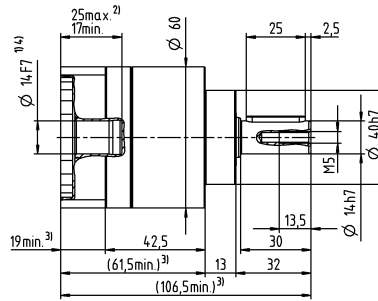
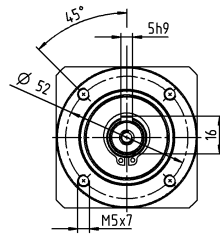

Motor shaft diameter [mm]

up to 19⁴⁾ (E)
clamping hub
diameter

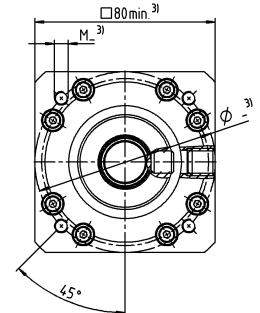
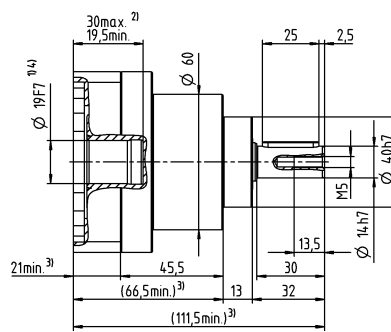
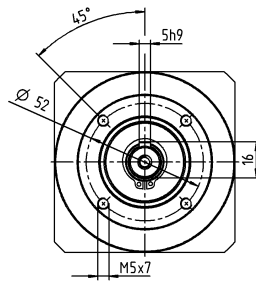

Other output variants

Smooth shaft

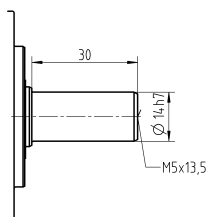

Replaceable B5 output flange

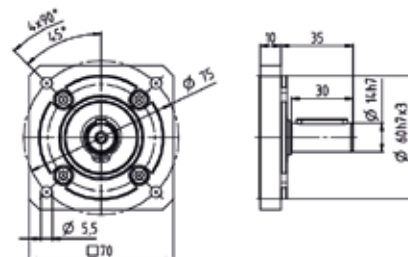

Non-tolerated dimensions are nominal dimensions

¹⁾ Check motor shaft fit

²⁾ Min. / Max. permissible motor shaft length

Longer motor shafts are possible, please contact alpha

³⁾ The dimensions depend on the motor

⁴⁾ Smaller motor shaft diameter is compensated by a bushing with a minimum wall thickness of 1 mm

⁵⁾ Standard clamping hub diameter

CPS 015 MF 2-stage

			2-stage														
Ratio	i		9	12	15	16	20	25	28	30	35	40	50	70	100		
Max. torque ^{a) b) e)}	T_{2a}	Nm	48	48	48	56	56	58	56	48	58	56	58	58	56		
		in.lb	425	425	425	496	496	513	496	425	513	496	513	513	496		
Max. acceleration torque ^{b)} (max. 1000 cycles per hour)	T_{2B}	Nm	30	30	30	35	35	40	35	30	40	35	40	40	35		
		in.lb	266	266	266	310	310	354	310	266	354	310	354	354	310		
Emergency stop torque ^{a) b) e)} (permitted 1000 times during the service life of the gearbox)	T_{2Not}	Nm	75	75	75	75	75	75	75	75	75	75	75	75	75		
		in.lb	664	664	664	664	664	664	664	664	664	664	664	664	664		
Permitted average input speed ^{d)} (at T_{2a} and 20 °C ambient temperature)	n_{1N}	rpm	3300	3300	3300	3300	3300	3300	3300	3300	3300	3300	3300	4000	4000		
Max. input speed	n_{1Max}	rpm	7000	7000	7000	7000	7000	7000	7000	7000	7000	7000	7000	7000	7000		
Mean no load running torque ^{b)} (at $n_1=3000$ rpm and 20 °C gearbox temperature)	T_{012}	Nm	0.33	0.28	0.26	0.25	0.22	0.21	0.2	0.21	0.18	0.17	0.16	0.15	0.14		
		in.lb	2.9	2.5	2.3	2.2	1.9	1.9	1.8	1.9	1.6	1.5	1.4	1.3	1.2		
Max. backlash	j_t	arcmin	≤ 15														
Torsional rigidity ^{b)}	C_{t21}	Nm/arcmin	2.1	2.1	2.1	2.1	2.1	2.1	2.1	2.1	2.1	2.1	2.1	2.1	1.9		
		in.lb/arcmin	19	19	19	19	19	19	19	19	19	19	19	19	17		
Max. axial force ^{c)}	F_{2AMax}	N	750														
		lb _f	169														
Max. lateral force ^{c)}	F_{2OMax}	N	500														
		lb _f	113														
Max. tilting moment	M_{2KMax}	Nm	17														
		in.lb	150														
Efficiency at full load	η	%	95														
Service life	L_h	h	> 20000														
Weight (incl. standard adapter plate)	m	kg	1.8														
		lb _m	4														
Operating noise (at reference ratio and reference speed – ratio-specific values available in cymex®)	L_{PA}	dB(A)	≤ 60														
Max. permitted housing temperature		°C	+90														
		°F	+194														
Ambient temperature		°C	-15 to +40														
		°F	+5 to +104														
Lubrication			Lubricated for life														
Direction of rotation			In- and output same direction														
Protection class			IP 64														
Elastomer coupling (recommended product type – validate sizing with cymex®) Bore diameter of coupling on the application side			ELC-0020BA014.000-X														
		mm	X = 008.000 - 025.000														
Mass moment of inertia (relates to the drive) Clamping hub diameter [mm]	C	14	J_1	kgcm ²	0.22	0.22	0.21	0.2	0.19	0.18	0.17	0.19	0.16	0.17	0.16	0.15	0.15
				10 ⁻³ in.lb.s ²	0.19	0.19	0.19	0.18	0.17	0.16	0.17	0.14	0.15	0.14	0.13	0.13	
	E	19	J_1	kgcm ²	0.43	0.42	0.42	0.4	0.4	0.39	0.39	0.41	0.39	0.39	0.38	0.38	0.37
				10 ⁻³ in.lb.s ²	0.38	0.37	0.37	0.35	0.35	0.35	0.35	0.36	0.35	0.35	0.34	0.34	0.33

Please use our sizing software cymex® for a detailed sizing – www.wittenstein-cymex.com

^{a)} Valid for torque transmission only

^{b)} Valid for standard clamping hub diameter

^{c)} Refers to center of the output shaft or flange

^{d)} Please reduce input speed at higher ambient temperatures

^{e)} Valid for: Smooth shaft

2-stage

Motor shaft diameter [mm]

up to 14⁴⁾ (C)⁵⁾
clamping hub
diameter

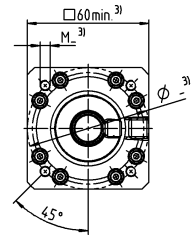
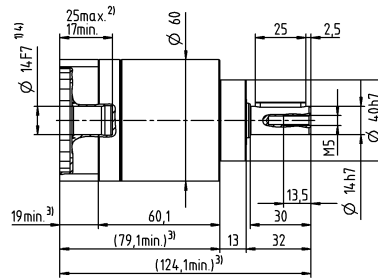
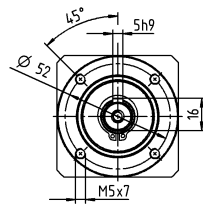

up to 19⁴⁾ (E)
clamping hub
diameter

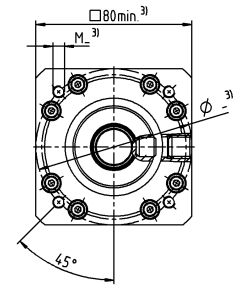
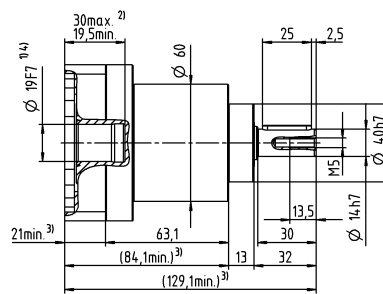
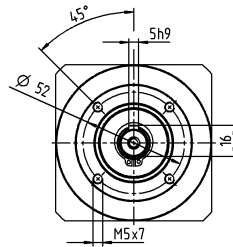

Planetary Gearboxes
Basic Line

Other output variants

Smooth shaft

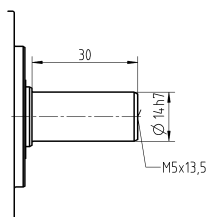

Replaceable B5 output flange

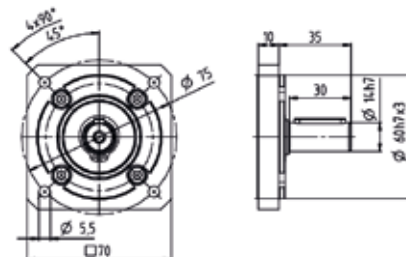

Non-tolerated dimensions are nominal dimensions

¹⁾ Check motor shaft fit

²⁾ Min. / Max. permissible motor shaft length

Longer motor shafts are possible, please contact alpha

³⁾ The dimensions depend on the motor

⁴⁾ Smaller motor shaft diameter is compensated by a bushing with a minimum wall thickness of 1 mm

⁵⁾ Standard clamping hub diameter

CPS 025 MF 1-stage

			1-stage							
Ratio	i		3	4	5	7	8	10		
Max. torque ^{a) b) e)}	T_{2a}	Nm	112	150	150	150	144	144		
		in.lb	991	1328	1328	1328	1275	1275		
Max. acceleration torque ^{b)} (max. 1000 cycles per hour)	T_{2B}	Nm	70	95	100	100	90	90		
		in.lb	620	841	885	885	797	797		
Emergency stop torque ^{a) b) e)} (permitted 1000 times during the service life of the gearbox)	T_{2Not}	Nm	114	152	187	187	187	187		
		in.lb	1009	1345	1655	1655	1655	1655		
Permitted average input speed ^{d)} (at T_{2a} and 20 °C ambient temperature)	n_{1N}	rpm	3100	3100	3100	3600	3600	3600		
Max. input speed	n_{1Max}	rpm	7000	7000	7000	7000	7000	7000		
Mean no load running torque ^{b)} (at $n_1=3000$ rpm and 20 °C gearbox temperature)	T_{012}	Nm	0.38	0.3	0.26	0.23	0.21	0.19		
		in.lb	3.4	2.7	2.3	2	1.9	1.7		
Max. backlash	j_t	arcmin	≤ 12							
Torsional rigidity ^{b)}	C_{t21}	Nm/arcmin	6.1	6.1	6.1	6.1	5.5	5.5		
		in.lb/arcmin	54	54	54	54	49	49		
Max. axial force ^{c)}	F_{2AMax}	N	1600							
		lb _f	360							
Max. lateral force ^{c)}	F_{2OMax}	N	1200							
		lb _f	270							
Max. tilting moment	M_{2KMMax}	Nm	54							
		in.lb	478							
Efficiency at full load	η	%	97							
Service life	L_h	h	> 20000							
Weight (incl. standard adapter plate)	m	kg	2.9							
		lb _m	6.4							
Operating noise (at reference ratio and reference speed – ratio-specific values available in cymex®)	L_{PA}	dB(A)	≤ 62							
Max. permitted housing temperature		°C	+90							
		°F	+194							
Ambient temperature		°C	-15 to +40							
		°F	+5 to +104							
Lubrication			Lubricated for life							
Direction of rotation			In- and output same direction							
Protection class			IP 64							
Elastomer coupling (recommended product type – validate sizing with cymex®)			ELC-0060BA020.000-X							
Bore diameter of coupling on the application side		mm	X = 012.000 - 032.000							
Mass moment of inertia (relates to the drive) Clamping hub diameter [mm]	E	19	J_1	kgcm ²	0.66	0.53	0.48	0.43	0.41	0.4
				10 ⁻³ in.lb.s ²	0.58	0.47	0.42	0.38	0.36	0.35
	G	24	J_1	kgcm ²	1.5	1.4	1.3	1.3	1.3	1.3
				10 ⁻³ in.lb.s ²	1.3	1.2	1.2	1.2	1.2	1.2

Please use our sizing software cymex® for a detailed sizing – www.wittenstein-cymex.com

^{a)} Valid for torque transmission only

^{b)} Valid for standard clamping hub diameter

^{c)} Refers to center of the output shaft or flange

^{d)} Please reduce input speed at higher ambient temperatures

^{e)} Valid for: Smooth shaft

1-stage

up to 19⁴⁾ (E)⁵⁾
clamping hub
diameter

Motor shaft diameter [mm]

up to 24⁴⁾ (G)
clamping hub
diameter

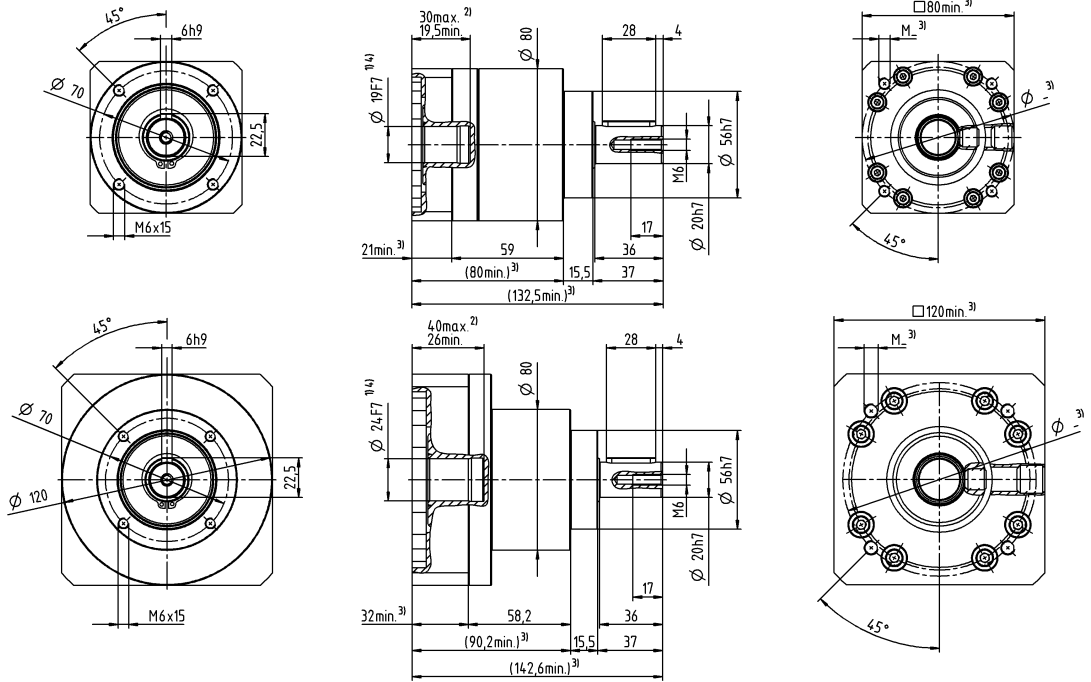

Planetary Gearboxes
Basic Line

Other output variants

Smooth shaft

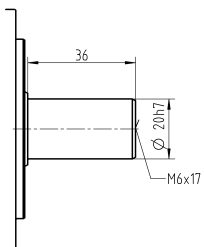

Replaceable B5 output flange

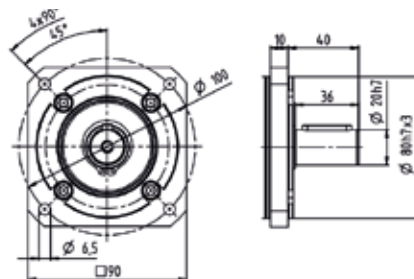

- Non-tolerated dimensions are nominal dimensions
- ¹⁾ Check motor shaft fit
- ²⁾ Min. / Max. permissible motor shaft length
Longer motor shafts are possible, please contact alpha
- ³⁾ The dimensions depend on the motor
- ⁴⁾ Smaller motor shaft diameter is compensated by a bushing with a minimum wall thickness of 1 mm
- ⁵⁾ Standard clamping hub diameter

CPS 025 MF 2-stage

			2-stage														
Ratio	i		9	12	15	16	20	25	28	30	35	40	50	70	100		
Max. torque ^{a) b) e)}	T_{2a}	Nm	112	112	112	150	150	150	150	112	150	150	150	150	144		
		in.lb	991	991	991	1328	1328	1328	1328	991	1328	1328	1328	1328	1328	1275	
Max. acceleration torque ^{b)} (max. 1000 cycles per hour)	T_{2B}	Nm	70	70	70	95	95	95	95	70	100	95	100	100	90		
		in.lb	620	620	620	841	841	841	841	620	885	841	885	885	797		
Emergency stop torque ^{a) b) e)} (permitted 1000 times during the service life of the gearbox)	T_{2Not}	Nm	187	187	187	187	187	187	187	187	187	187	187	187	187		
		in.lb	1655	1655	1655	1655	1655	1655	1655	1655	1655	1655	1655	1655	1655		
Permitted average input speed ^{d)} (at T_{2a} and 20 °C ambient temperature)	n_{1N}	rpm	3100	3100	3100	3100	3100	3100	3100	3100	3100	3100	3100	3600	3600		
Max. input speed	n_{1Max}	rpm	7000	7000	7000	7000	7000	7000	7000	7000	7000	7000	7000	7000	7000		
Mean no load running torque ^{b)} (at $n_1=3000$ rpm and 20 °C gearbox temperature)	T_{012}	Nm	0.5	0.43	0.39	0.38	0.34	0.32	0.3	0.31	0.28	0.26	0.24	0.22	0.21		
		in.lb	4.4	3.8	3.5	3.4	3	2.8	2.7	2.7	2.5	2.3	2.1	1.9	1.9		
Max. backlash	j_t	arcmin	≤ 15														
Torsional rigidity ^{b)}	C_{t21}	Nm/arcmin	6.1	6.1	6.1	6.1	6.1	6.1	6.1	6.1	6.1	6.1	6.1	6.1	5.5		
		in.lb/arcmin	54	54	54	54	54	54	54	54	54	54	54	54	49		
Max. axial force ^{c)}	F_{2AMax}	N	1600														
		lb _f	360														
Max. lateral force ^{c)}	F_{2OMax}	N	1200														
		lb _f	270														
Max. tilting moment	M_{2KMMax}	Nm	54														
		in.lb	478														
Efficiency at full load	η	%	95														
Service life	L_h	h	> 20000														
Weight (incl. standard adapter plate)	m	kg	3.7														
		lb _m	8.2														
Operating noise (at reference ratio and reference speed – ratio-specific values available in cymex®)	L_{PA}	dB(A)	≤ 62														
Max. permitted housing temperature		°C	+90														
		°F	+194														
Ambient temperature		°C	-15 to +40														
		°F	+5 to +104														
Lubrication			Lubricated for life														
Direction of rotation			In- and output same direction														
Protection class			IP 64														
Elastomer coupling (recommended product type – validate sizing with cymex®)			ELC-0060BA020.000-X														
Bore diameter of coupling on the application side		mm	X = 012.000 - 032.000														
Mass moment of inertia (relates to the drive) Clamping hub diameter [mm]	E	19	J_1	kgcm ²	0.66	1.4	1.6	0.98	1.1	0.82	1.2	2.1	0.88	1.4	1	0.71	0.54
				10 ⁻³ in.lb.s ²	0.58	1.2	1.4	0.87	0.97	0.73	1.1	1.9	0.78	1.2	0.89	0.63	0.48
	G	24	J_1	kgcm ²	1.5	2.3	2.4	1.8	1.9	1.7	2	3	1.7	2.2	1.9	1.6	1.4
				10 ⁻³ in.lb.s ²	1.3	2	2.1	1.6	1.7	1.5	1.8	2.7	1.5	1.9	1.7	1.4	1.2

Please use our sizing software cymex® for a detailed sizing – www.wittenstein-cymex.com

^{a)} Valid for torque transmission only

^{b)} Valid for standard clamping hub diameter

^{c)} Refers to center of the output shaft or flange

^{d)} Please reduce input speed at higher ambient temperatures

^{e)} Valid for: Smooth shaft

2-stage

up to 19⁴⁾ (E)⁵⁾
clamping hub diameter

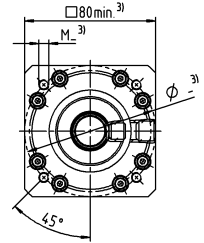
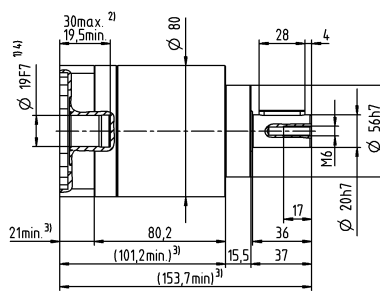
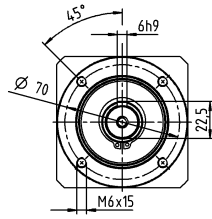

Motor shaft diameter [mm]

up to 24⁴⁾ (G)
clamping hub diameter

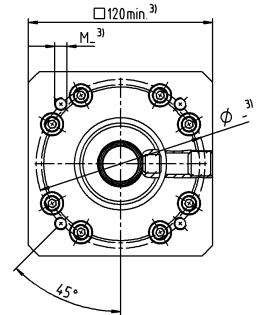
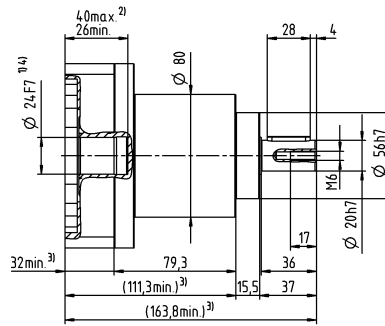
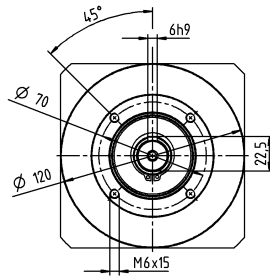

Other output variants

Smooth shaft

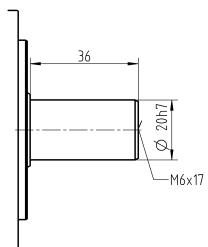

Replaceable B5 output flange

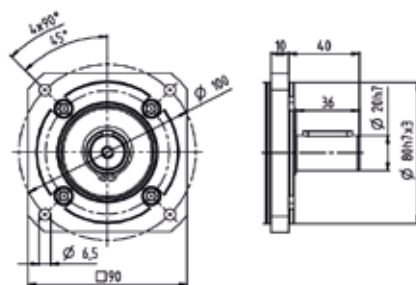

Non-tolerated dimensions are nominal dimensions

¹⁾ Check motor shaft fit

²⁾ Min. / Max. permissible motor shaft length

Longer motor shafts are possible, please contact alpha

³⁾ The dimensions depend on the motor

⁴⁾ Smaller motor shaft diameter is compensated by a bushing with a minimum wall thickness of 1 mm

⁵⁾ Standard clamping hub diameter

CPS 035 MF 1-stage

			1-stage							
Ratio	i		3	4	5	7	8	10		
Max. torque ^{a) b) e)}	T_{2a}	Nm	272	272	272	272	272	272		
		in.lb	2407	2407	2407	2407	2407	2407		
Max. acceleration torque ^{b)} (max. 1000 cycles per hour)	T_{2B}	Nm	175	255	250	250	220	220		
		in.lb	1549	2257	2213	2213	1947	1947		
Emergency stop torque ^{a) b) e)} (permitted 1000 times during the service life of the gearbox)	T_{2Not}	Nm	460	480	480	480	470	480		
		in.lb	4071	4248	4248	4248	4160	4248		
Permitted average input speed ^{d)} (at T_{2a} and 20 °C ambient temperature)	n_{1N}	rpm	2300	2300	2300	2800	2800	2800		
Max. input speed	n_{1Max}	rpm	5500	5500	5500	5500	5500	5500		
Mean no load running torque ^{b)} (at $n_1=3000$ rpm and 20 °C gearbox temperature)	T_{012}	Nm	0.95	0.76	0.66	0.57	0.52	0.48		
		in.lb	8.4	6.7	5.8	5	4.6	4.2		
Max. backlash	j_t	arcmin	≤ 12							
Torsional rigidity ^{b)}	C_{t21}	Nm/arcmin	16	16	16	16	14	14		
		in.lb/arcmin	142	142	142	142	124	124		
Max. axial force ^{c)}	F_{2AMax}	N	2500							
		lb _f	563							
Max. lateral force ^{c)}	F_{2OMax}	N	1750							
		lb _f	394							
Max. tilting moment	M_{2KMMax}	Nm	98							
		in.lb	867							
Efficiency at full load	η	%	97							
Service life	L_h	h	> 20000							
Weight (incl. standard adapter plate)	m	kg	7.5							
		lb _m	17							
Operating noise (at reference ratio and reference speed – ratio-specific values available in cymex®)	L_{PA}	dB(A)	≤ 66							
Max. permitted housing temperature		°C	+90							
		°F	+194							
Ambient temperature		°C	-15 to +40							
		°F	+5 to +104							
Lubrication			Lubricated for life							
Direction of rotation			In- and output same direction							
Protection class			IP 64							
Elastomer coupling (recommended product type – validate sizing with cymex®)			ELC-0150BA025.000-X							
Bore diameter of coupling on the application side		mm	X = 019.000 - 036.000							
Mass moment of inertia (relates to the drive) Clamping hub diameter [mm]	G	24	J_1	kgcm ²	2.6	1.9	1.7	1.5	1.4	1.4
				10 ⁻³ in.lb.s ²	2.3	1.7	1.5	1.3	1.2	1.2
	K	38	J_1	kgcm ²	7.8	7.1	6.9	6.7	6.6	6.5
				10 ⁻³ in.lb.s ²	6.9	6.3	6.1	5.9	5.8	5.8

Please use our sizing software cymex® for a detailed sizing – www.wittenstein-cymex.com

^{a)} Valid for torque transmission only

^{b)} Valid for standard clamping hub diameter

^{c)} Refers to center of the output shaft or flange

^{d)} Please reduce input speed at higher ambient temperatures

^{e)} Valid for: Smooth shaft

1-stage

up to 24⁴⁾ (G)⁵⁾
clamping hub
diameter

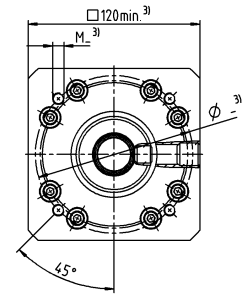
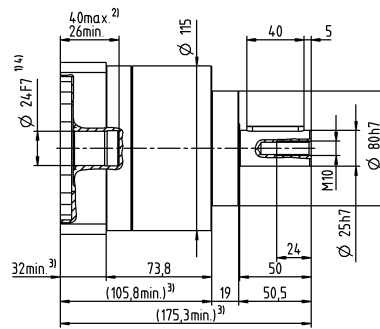
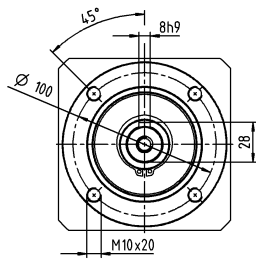

Motor shaft diameter [mm]

up to 38⁴⁾ (K)
clamping hub
diameter

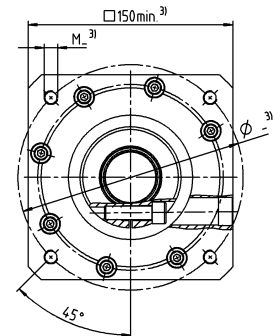
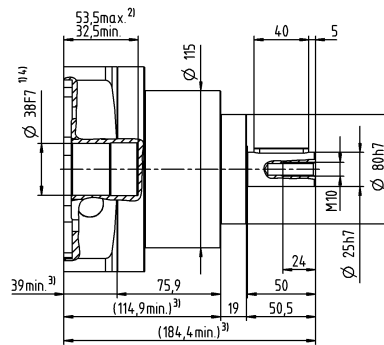
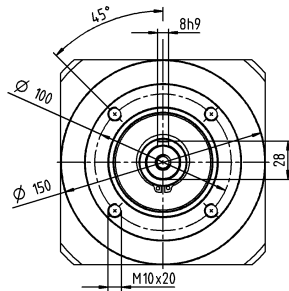

Planetary Gearboxes
Basic Line

Other output variants

Smooth shaft

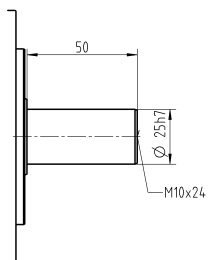

Replaceable B5 output flange

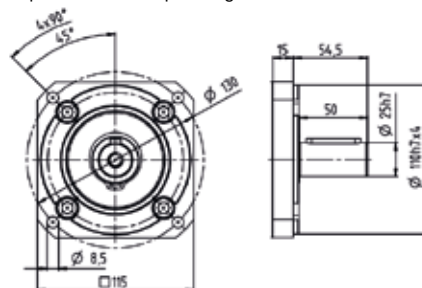

Non-tolerated dimensions are nominal dimensions

¹⁾ Check motor shaft fit

²⁾ Min. / Max. permissible motor shaft length

Longer motor shafts are possible, please contact alpha

³⁾ The dimensions depend on the motor

⁴⁾ Smaller motor shaft diameter is compensated

by a bushing with a minimum wall thickness of 1 mm

⁵⁾ Standard clamping hub diameter

CPS 035 MF 2-stage

			2-stage														
Ratio	i		9	12	15	16	20	25	28	30	35	40	50	70	100		
Max. torque ^{a) b) e)}	T_{2a}	Nm	272	272	272	272	272	272	272	272	272	272	272	272	272		
		in.lb	2407	2407	2407	2407	2407	2407	2407	2407	2407	2407	2407	2407	2407	2407	
Max. acceleration torque ^{b)} (max. 1000 cycles per hour)	T_{2B}	Nm	175	175	175	255	255	250	255	175	250	255	250	250	220		
		in.lb	1549	1549	1549	2257	2257	2213	2257	1549	2213	2257	2213	2213	1947		
Emergency stop torque ^{a) b) e)} (permitted 1000 times during the service life of the gearbox)	T_{2Not}	Nm	480	480	480	480	480	480	480	315	480	480	480	480	480		
		in.lb	4248	4248	4248	4248	4248	4248	4248	2788	4248	4248	4248	4248	4248		
Permitted average input speed ^{d)} (at T_{2a} and 20 °C ambient temperature)	n_{1N}	rpm	2300	2300	2300	2300	2300	2300	2300	2300	2300	2300	2300	2800	2800		
Max. input speed	n_{1Max}	rpm	5500	5500	5500	5500	5500	5500	5500	5500	5500	5500	5500	5500	5500		
Mean no load running torque ^{b)} (at $n_1=3000$ rpm and 20 °C gearbox temperature)	T_{012}	Nm	1.3	1.1	0.98	0.95	0.85	0.8	0.76	0.79	0.7	0.66	0.61	0.56	0.52		
		in.lb	12	9.7	8.7	8.4	7.5	7.1	6.7	7	6.2	5.8	5.4	5	4.6		
Max. backlash	j_t	arcmin	≤ 15														
Torsional rigidity ^{b)}	C_{t21}	Nm/arcmin	16	16	16	16	16	16	16	16	16	16	16	16	14		
		in.lb/arcmin	142	142	142	142	142	142	142	142	142	142	142	142	124		
Max. axial force ^{c)}	F_{2AMax}	N	2500														
		lb _f	563														
Max. lateral force ^{c)}	F_{2OMax}	N	1750														
		lb _f	394														
Max. tilting moment	M_{2KMax}	Nm	98														
		in.lb	867														
Efficiency at full load	η	%	95														
Service life	L_h	h	> 20000														
Weight (incl. standard adapter plate)	m	kg	9.6														
		lb _m	21														
Operating noise (at reference ratio and reference speed – ratio-specific values available in cymex®)	L_{PA}	dB(A)	≤ 66														
Max. permitted housing temperature		°C	+90														
		°F	+194														
Ambient temperature		°C	-15 to +40														
		°F	+5 to +104														
Lubrication			Lubricated for life														
Direction of rotation			In- and output same direction														
Protection class			IP 64														
Elastomer coupling (recommended product type – validate sizing with cymex®)			ELC-0150BA025.000-X														
Bore diameter of coupling on the application side		mm	X = 019.000 - 036.000														
Mass moment of inertia (relates to the drive) Clamping hub diameter [mm]	G	24	J_1	kgcm ²	2.7	2.5	2.5	2.3	2.3	2.1	2.4	3.1	2.2	2.6	2.2	1.9	1.7
				10 ⁻³ in.lb.s ²	2.4	2.2	2.2	2	2	1.9	2.1	2.7	1.9	2.3	1.9	1.7	1.5
	K	38	J_1	kgcm ²	7.9	7.7	7.8	7.5	7.5	7.3	7.5	8.3	7.4	7.8	7.4	7.1	6.9
				10 ⁻³ in.lb.s ²	7	6.8	6.9	6.6	6.6	6.5	6.6	7.3	6.5	6.9	6.5	6.3	6.1

Please use our sizing software cymex® for a detailed sizing – www.wittenstein-cymex.com

^{a)} Valid for torque transmission only

^{b)} Valid for standard clamping hub diameter

^{c)} Refers to center of the output shaft or flange

^{d)} Please reduce input speed at higher ambient temperatures

^{e)} Valid for: Smooth shaft

2-stage

up to 24⁴⁾ (G)⁵⁾
clamping hub diameter

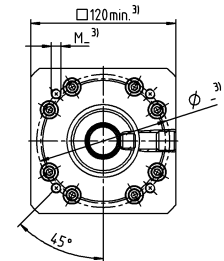
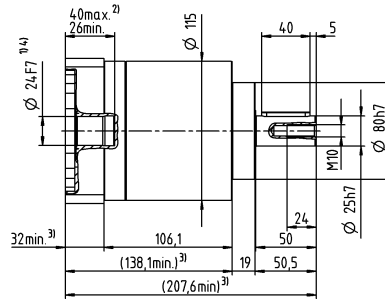
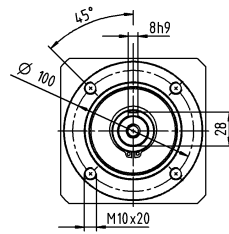

Motor shaft diameter [mm]

up to 38⁴⁾ (K)
clamping hub diameter

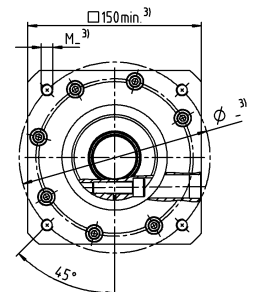
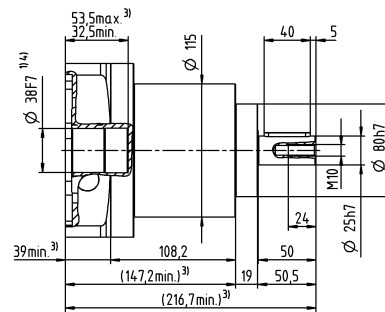
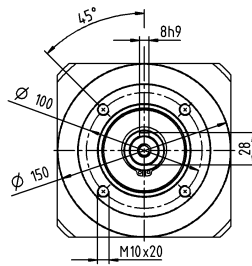

Planetary Gearboxes
Basic Line

Other output variants

Smooth shaft

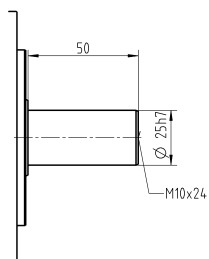

Replaceable B5 output flange

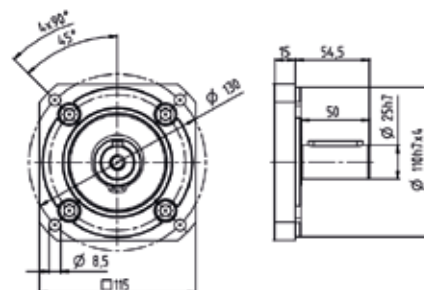

Non-tolerated dimensions are nominal dimensions

¹⁾ Check motor shaft fit

²⁾ Min. / Max. permissible motor shaft length

Longer motor shafts are possible, please contact alpha

³⁾ The dimensions depend on the motor

⁴⁾ Smaller motor shaft diameter is compensated by a bushing with a minimum wall thickness of 1 mm

⁵⁾ Standard clamping hub diameter

alpha Basic Line

BEVEL GEARBOXES CPK / CPSK

The bevel gearboxes of the alpha Basic Line achieve a high power density thanks to the specially designed toothing. Thus they can optimally combine the benefits of a planetary gearbox and an angle section. The extremely compact design also enables use in confined installation situations.

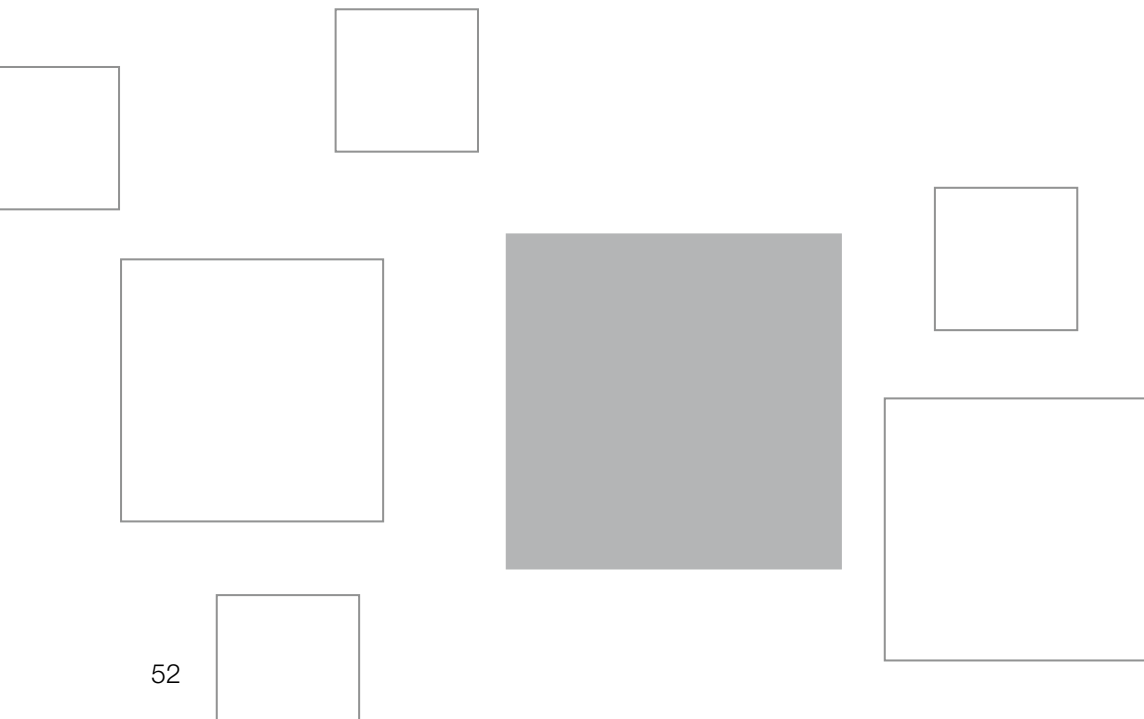

CPK

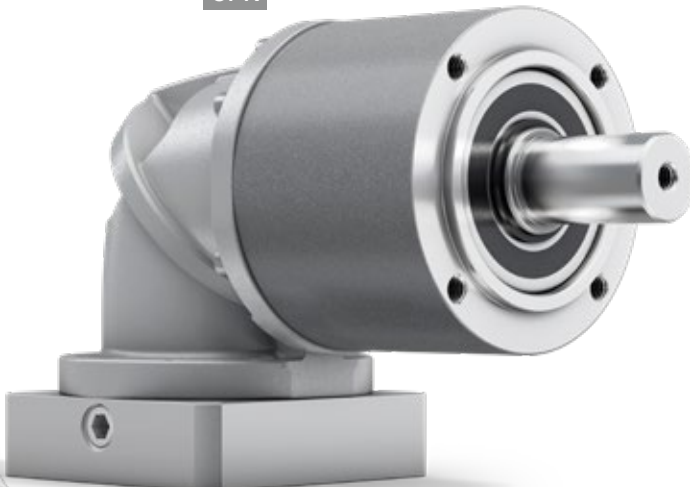

CPSK

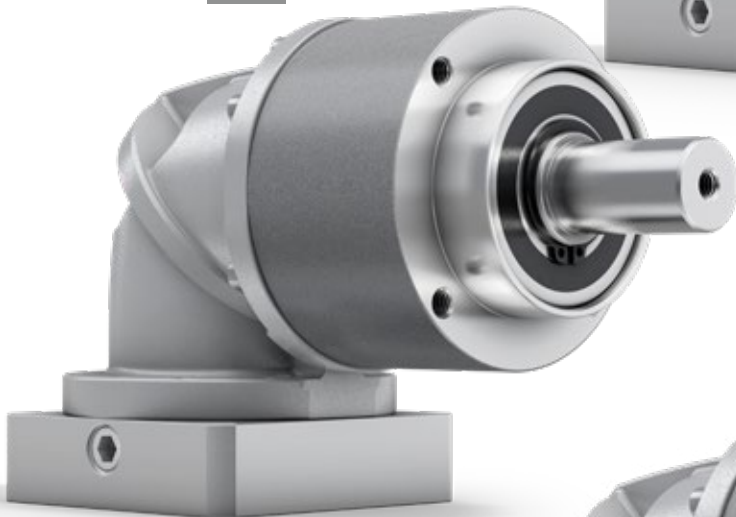

CPSK*

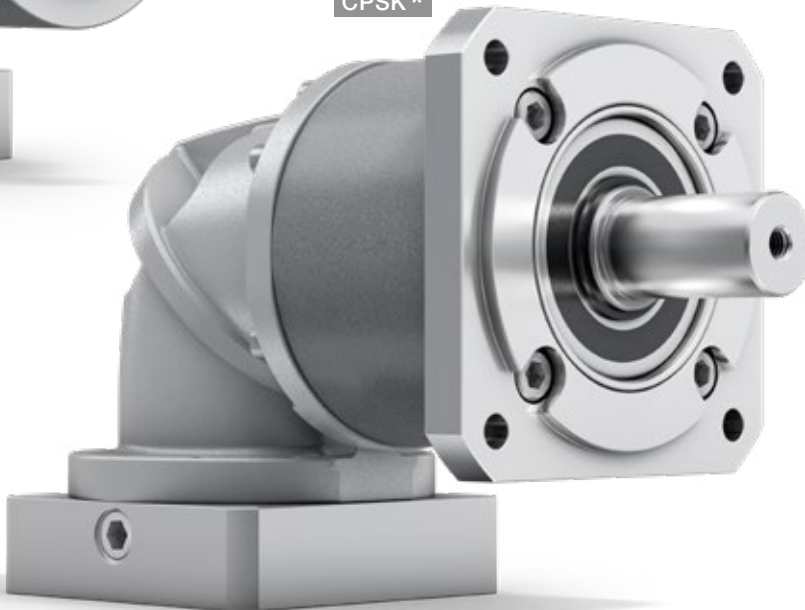

* CPSK with replaceable B5 output flange

CPK / CPSK – Geared up to Fit

CPK

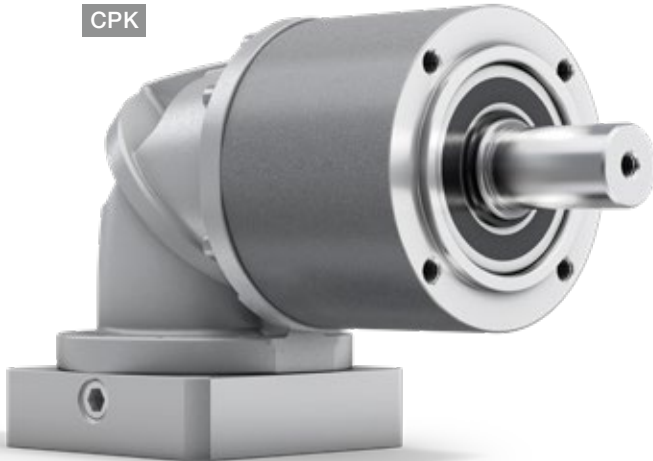

Economically around the corner. The right-angle gearboxes of the alpha Basic Line are specially designed for applications with medium requirements for positioning accuracy. The extremely compact bevel gear stage enables use in applications with space constraints.

PRODUCT HIGHLIGHTS

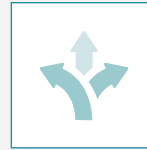

High flexibility

Various output variants offer design freedom tailored to individual requirements.



Maximum economy

The alpha Basic Line is extremely economical to purchase and highly efficient in operation.



High power density

The gearboxes offer high power density in the smallest installation space.



Quick sizing

Efficient and innovative online sizing within seconds in cymex® select based on technical and economic suitability.

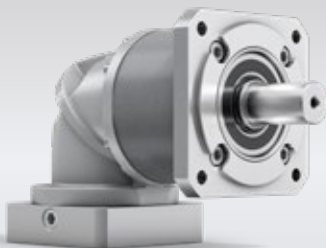

CPSK – bevel gearbox with replaceable B5 output flange

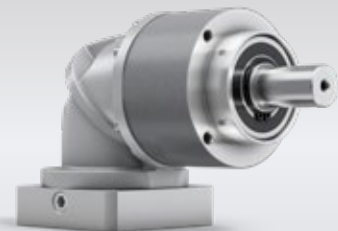

CPSK – bevel gearbox with long centering

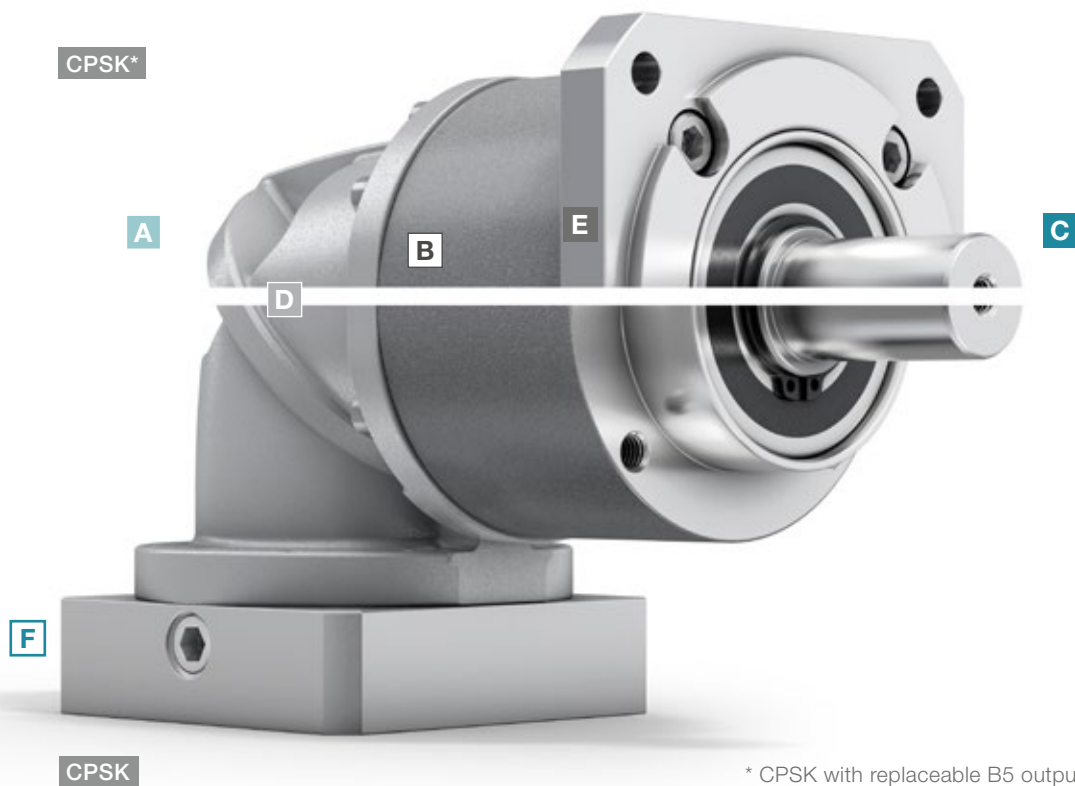

* CPSK with replaceable B5 output flange

A Variety of sizes

- CPK available in five different sizes (005 – 045)
- CPSK available in three different sizes (015 – 035)

B High ratio variation

- Large number of ratios ($i=3$ to $i=100$)
- Available in the common binary ratios

C Available output types

- Smooth shaft
- Shaft with key

D Compactness

- The extremely compact design of the angle section enables use in very confined installation spaces

E Variable application connection

- Shortened installation space and maximum compactness thanks to a long centering
- Flange attachment for B5 mounting

F Flexible motor connection

- As with the planetary gearboxes of the alpha Basic Line, mounting of all common servo motors takes place by means of a flexible and screw-fastened adapter plate
- Large number of motor shaft diameters connectable



CPK – bevel gearbox with elastomer coupling



cymex® select
BEST SOLUTION WITHIN SECONDS

Efficient gearbox sizing within seconds – online and without login
cymex-select.wittenstein-group.com

CPK 005 MF 2-stage

			2-stage					
Ratio	i		4	5	7	8	10	
Max. torque ^{a) b) e)}	T_{2a}	Nm	14	17	21	20	20	
		in.lb	124	150	186	177	177	
Max. acceleration torque ^{e)} (max. 1000 cycles per hour)	T_{2B}	Nm	6.8	8.5	12	13	13	
		in.lb	60	75	106	115	115	
Emergency stop torque ^{a) b) e)} (permitted 1000 times during the service life of the gearbox)	T_{2Not}	Nm	17	21	26	26	26	
		in.lb	150	186	230	230	230	
Permitted average input speed ^{d)} (at T_{2a} and 20 °C ambient temperature)	n_{1N}	rpm	3800	3800	3800	3800	3800	
Max. input speed	n_{1Max}	rpm	5000	5000	5000	5000	5000	
Mean no load running torque ^{b)} (at $n_1=3000$ rpm and 20 °C gearbox temperature)	T_{012}	Nm	0.25	0.25	0.25	0.25	0.25	
		in.lb	2.2	2.2	2.2	2.2	2.2	
Max. backlash	j_t	arcmin	≤ 17					
Torsional rigidity ^{b)}	C_{t21}	Nm/arcmin	0.5	0.5	0.5	0.5	0.5	
		in.lb/arcmin	4.4	4.4	4.4	4.4	4.4	
Max. axial force ^{c)}	F_{2AMax}	N	240					
		lb _f	54					
Max. lateral force ^{c) 1)}	F_{2QMax}	N	170					
		lb _f	38					
Max. tilting moment	M_{2KMMax}	Nm	4					
		in.lb	35					
Efficiency at full load	η	%	95					
Service life	L_h	h	> 20000					
Weight (incl. standard adapter plate)	m	kg	0.86					
		lb _m	1.9					
Operating noise (at reference ratio and reference speed – ratio-specific values available in cymex®)	L_{PA}	dB(A)	≤ 68					
Max. permitted housing temperature		°C	+90					
		°F	+194					
Ambient temperature		°C	0 to +40					
		°F	+32 to +104					
Lubrication			Lubricated for life					
Direction of rotation			In- and output same direction					
Protection class			IP 64					
Elastomer coupling (recommended product type – validate sizing with cymex®)			ELC-0005BA010.000-X					
Bore diameter of coupling on the application side		mm	X = 004.000 - 012.700					
Mass moment of inertia (relates to the drive) Clamping hub diameter [mm]	B 11	J_1	kgcm ²	0.13	0.13	0.13	0.13	0.13
			10 ⁻³ in.lb.s ²	0.12	0.12	0.12	0.12	0.12

Please use our sizing software cymex® for a detailed sizing – www.wittenstein-cymex.com
Please consider the maximum permissible tilting moment caused by the motor M_{1KMot} – see sizing

- ^{a)} Valid for torque transmission only
- ^{b)} Valid for standard clamping hub diameter
- ^{c)} Refers to center of the output shaft or flange
- ^{d)} Please reduce input speed at higher ambient temperatures
- ^{e)} Valid for: Smooth shaft
- ¹⁾ At increased lateral forces – see glossary

Motor shaft diameter [mm]

2-stage

up to 11⁴⁾ (B)⁵⁾
clamping hub
diameter

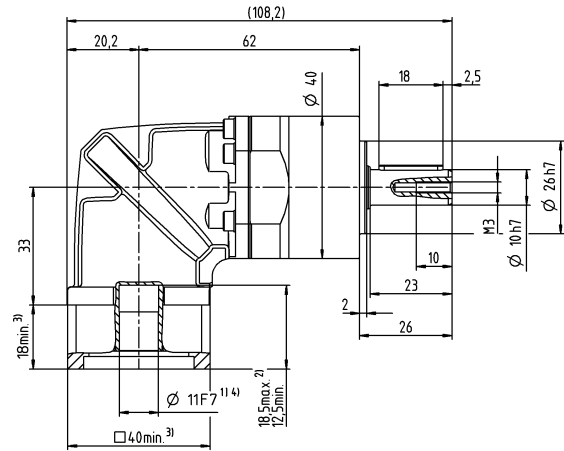
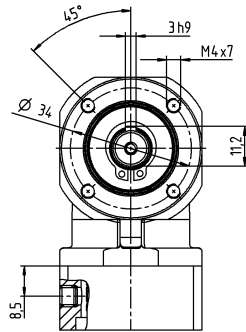

Bevel Gearboxes
Basic Line

Other output variants

Smooth shaft

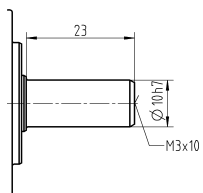

Non-tolerated dimensions are nominal dimensions

¹⁾ Check motor shaft fit

²⁾ Min. / Max. permissible motor shaft length

Longer motor shafts are possible, please contact alpha

³⁾ The dimensions depend on the motor

⁴⁾ Smaller motor shaft diameter is compensated by a bushing with a minimum wall thickness of 1 mm

⁵⁾ Standard clamping hub diameter

CPK 005 MF 3-stage

			3-stage									
Ratio	i		16	20	25	28	35	40	50	70	100	
Max. torque ^{a) b) e)}	T_{2a}	Nm	17	17	21	17	21	17	21	21	20	
		in.lb	150	150	186	150	186	150	186	186	177	
Max. acceleration torque ^{e)} (max. 1000 cycles per hour)	T_{2B}	Nm	11	11	14	11	14	11	14	14	13	
		in.lb	97	97	124	97	124	97	124	124	115	
Emergency stop torque ^{a) b) e)} (permitted 1000 times during the service life of the gearbox)	T_{2Not}	Nm	26	26	26	26	26	26	26	26	26	
		in.lb	230	230	230	230	230	230	230	230	230	
Permitted average input speed ^{d)} (at T_{2a} and 20 °C ambient temperature)	n_{1N}	rpm	3800	3800	3800	3800	3800	3800	3800	3800	3800	
Max. input speed	n_{1Max}	rpm	5000	5000	5000	5000	5000	5000	5000	5000	5000	
Mean no load running torque ^{b)} (at $n_1=3000$ rpm and 20 °C gearbox temperature)	T_{012}	Nm	0.27	0.27	0.27	0.27	0.27	0.27	0.27	0.27	0.27	
		in.lb	2.4	2.4	2.4	2.4	2.4	2.4	2.4	2.4	2.4	
Max. backlash	j_t	arcmin	≤ 20									
Torsional rigidity ^{b)}	C_{t21}	Nm/arcmin	0.57	0.57	0.57	0.57	0.57	0.57	0.57	0.57	0.57	
		in.lb/arcmin	5	5	5	5	5	5	5	5	5	
Max. axial force ^{c)}	F_{2AMax}	N	240									
		lb _f	54									
Max. lateral force ^{c) 1)}	F_{2QMMax}	N	170									
		lb _f	38									
Max. tilting moment	M_{2KMMax}	Nm	4									
		in.lb	35									
Efficiency at full load	η	%	94									
Service life	L_n	h	> 20000									
Weight (incl. standard adapter plate)	m	kg	0.92									
		lb _m	2.0									
Operating noise (at reference ratio and reference speed – ratio-specific values available in cymex®)	L_{PA}	dB(A)	≤ 68									
Max. permitted housing temperature		°C	+90									
		°F	+194									
Ambient temperature		°C	0 to +40									
		°F	+32 to +104									
Lubrication			Lubricated for life									
Direction of rotation			In- and output same direction									
Protection class			IP 64									
Elastomer coupling (recommended product type – validate sizing with cymex®)			ELC-0005BA010.000-X									
Bore diameter of coupling on the application side		mm	X = 004.000 - 012.700									
Mass moment of inertia (relates to the drive) Clamping hub diameter [mm]	B	11	J_1	kgcm ²	0.13	0.13	0.13	0.13	0.13	0.13	0.13	0.13
				10 ⁻³ in.lb.s ²	0.12	0.12	0.12	0.12	0.12	0.12	0.12	0.12

Please use our sizing software cymex® for a detailed sizing – www.wittenstein-cymex.com
Please consider the maximum permissible tilting moment caused by the motor M_{1KMot} – see sizing

- ^{a)} Valid for torque transmission only
- ^{b)} Valid for standard clamping hub diameter
- ^{c)} Refers to center of the output shaft or flange
- ^{d)} Please reduce input speed at higher ambient temperatures
- ^{e)} Valid for: Smooth shaft
- ¹⁾ At increased lateral forces – see glossary

Motor shaft diameter [mm]

3-stage

up to 11⁴⁾ (B)⁵⁾
clamping hub
diameter

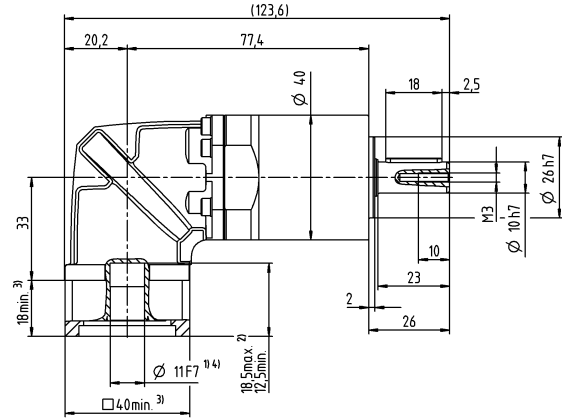
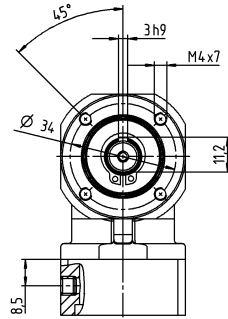

Bevel Gearboxes
Basic Line

Other output variants

Smooth shaft

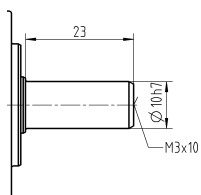

- Non-tolerated dimensions are nominal dimensions
- ¹⁾ Check motor shaft fit
- ²⁾ Min. / Max. permissible motor shaft length
Longer motor shafts are possible, please contact alpha
- ³⁾ The dimensions depend on the motor
- ⁴⁾ Smaller motor shaft diameter is compensated
by a bushing with a minimum wall thickness of 1 mm
- ⁵⁾ Standard clamping hub diameter

CPK 015 MF 2-stage

			2-stage						
Ratio	i		3	4	5	7	8	10	
Max. torque ^{a) b) e)}	T_{2a}	Nm	33	44	55	58	56	56	
		in.lb	292	389	487	513	496	496	
Max. acceleration torque ^{b)} (max. 1000 cycles per hour)	T_{2B}	Nm	16	21	27	37	35	35	
		in.lb	142	186	239	327	310	310	
Emergency stop torque ^{a) b) e)} (permitted 1000 times during the service life of the gearbox)	T_{2Not}	Nm	41	55	69	75	75	75	
		in.lb	363	487	611	664	664	664	
Permitted average input speed ^{d)} (at T_{2a} and 20 °C ambient temperature)	n_{1N}	rpm	3300	3300	3300	3300	3300	3300	
Max. input speed	n_{1Max}	rpm	5000	5000	5000	5000	5000	5000	
Mean no load running torque ^{b)} (at $n_1=3000$ rpm and 20 °C gearbox temperature)	T_{012}	Nm	0.55	0.55	0.55	0.55	0.55	0.55	
		in.lb	4.9	4.9	4.9	4.9	4.9	4.9	
Max. backlash	j_t	arcmin	≤ 17						
Torsional rigidity ^{b)}	C_{t21}	Nm/arcmin	1.7	1.7	1.7	1.7	1.7	1.7	
		in.lb/arcmin	15	15	15	15	15	15	
Max. axial force ^{c)}	F_{2AMax}	N	750						
		lb _f	169						
Max. lateral force ^{c) 1)}	F_{2QMax}	N	500						
		lb _f	113						
Max. tilting moment	M_{2KMMax}	Nm	17						
		in.lb	150						
Efficiency at full load	η	%	95						
Service life	L_h	h	> 20000						
Weight (incl. standard adapter plate)	m	kg	1.6						
		lb _m	3.5						
Operating noise (at reference ratio and reference speed – ratio-specific values available in cymex®)	L_{PA}	dB(A)	≤ 70						
Max. permitted housing temperature		°C	+90						
		°F	+194						
Ambient temperature		°C	0 to +40						
		°F	+32 to +104						
Lubrication			Lubricated for life						
Direction of rotation			In- and output same direction						
Protection class			IP 64						
Elastomer coupling (recommended product type – validate sizing with cymex®)			ELC-0020BA014.000-X						
Bore diameter of coupling on the application side		mm	X = 008.000 - 025.000						
Mass moment of inertia (relates to the drive) Clamping hub diameter [mm]	C 14	J_1	kgcm ²	0.3	0.3	0.3	0.3	0.3	0.3
			10 ⁻³ in.lb.s ²	0.27	0.27	0.27	0.27	0.27	0.27

Please use our sizing software cymex® for a detailed sizing – www.wittenstein-cymex.com
Please consider the maximum permissible tilting moment caused by the motor M_{1KMot} – see sizing

- ^{a)} Valid for torque transmission only
- ^{b)} Valid for standard clamping hub diameter
- ^{c)} Refers to center of the output shaft or flange
- ^{d)} Please reduce input speed at higher ambient temperatures
- ^{e)} Valid for: Smooth shaft
- ¹⁾ At increased lateral forces – see glossary

Motor shaft diameter [mm]

2-stage

up to 14⁴⁾ (C)⁵⁾
clamping hub
diameter

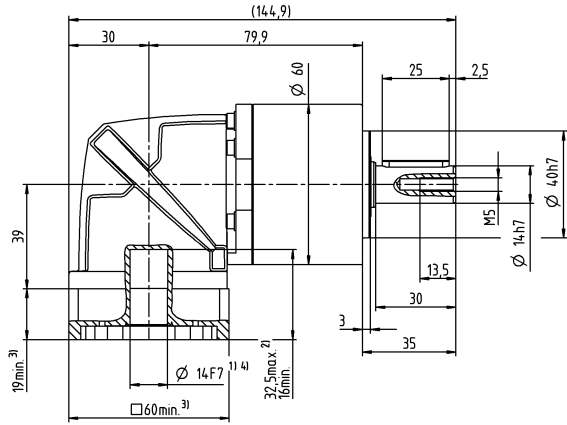
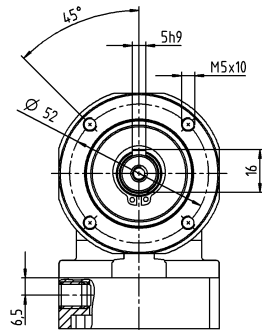

Bevel Gearboxes
Basic Line

Other output variants

Smooth shaft

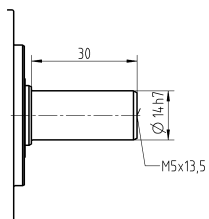

Non-tolerated dimensions are nominal dimensions

¹⁾ Check motor shaft fit

²⁾ Min. / Max. permissible motor shaft length

Longer motor shafts are possible, please contact alpha

³⁾ The dimensions depend on the motor

⁴⁾ Smaller motor shaft diameter is compensated

by a bushing with a minimum wall thickness of 1 mm

⁵⁾ Standard clamping hub diameter

CPK 015 MF 3-stage

			3-stage												
Ratio	i		9	12	15	16	20	25	28	30	35	40	50	70	100
Max. torque ^{a) b) e)}	T_{2a}	Nm	48	48	48	56	56	58	56	48	58	56	58	58	56
		in.lb	425	425	425	496	496	513	496	425	513	496	513	513	496
Max. acceleration torque ^{a)} (max. 1000 cycles per hour)	T_{2B}	Nm	30	30	30	35	35	40	35	30	40	35	40	40	35
		in.lb	266	266	266	310	310	354	310	266	354	310	354	354	310
Emergency stop torque ^{a) b) e)} (permitted 1000 times during the service life of the gearbox)	T_{2Not}	Nm	75	75	75	75	75	75	75	75	75	75	75	75	75
		in.lb	664	664	664	664	664	664	664	664	664	664	664	664	664
Permitted average input speed ^{d)} (at T_{2a} and 20 °C ambient temperature)	n_{1N}	rpm	3300	3300	3300	3300	3300	3300	3300	3300	3300	3300	3300	3300	3300
Max. input speed	n_{1Max}	rpm	5000	5000	5000	5000	5000	5000	5000	5000	5000	5000	5000	5000	5000
Mean no load running torque ^{b)} (at $n_1=3000$ rpm and 20 °C gearbox temperature)	T_{012}	Nm	0.63	0.63	0.63	0.63	0.63	0.63	0.63	0.63	0.63	0.63	0.63	0.63	0.63
		in.lb	5.6	5.6	5.6	5.6	5.6	5.6	5.6	5.6	5.6	5.6	5.6	5.6	5.6
Max. backlash	j_t	arcmin	≤ 17												
Torsional rigidity ^{b)}	C_{t21}	Nm/arcmin	2.1	2.1	2.1	2.1	2.1	2.1	2.1	2.1	2.1	2.1	2.1	2.1	2.1
		in.lb/arcmin	19	19	19	19	19	19	19	19	19	19	19	19	19
Max. axial force ^{c)}	F_{2AMax}	N	750												
		lb _f	169												
Max. lateral force ^{c) 1)}	F_{2QMax}	N	500												
		lb _f	113												
Max. tilting moment	M_{2KMMax}	Nm	17												
		in.lb	150												
Efficiency at full load	η	%	94												
Service life	L_h	h	> 20000												
Weight (incl. standard adapter plate)	m	kg	1.8												
		lb _m	4												
Operating noise (at reference ratio and reference speed – ratio-specific values available in cymex®)	L_{PA}	dB(A)	≤ 70												
Max. permitted housing temperature		°C	+90												
		°F	+194												
Ambient temperature		°C	0 to +40												
		°F	+32 to +104												
Lubrication			Lubricated for life												
Direction of rotation			In- and output same direction												
Protection class			IP 64												
Elastomer coupling (recommended product type – validate sizing with cymex®)			ELC-0020BA014.000-X												
Bore diameter of coupling on the application side		mm	X = 008.000 - 025.000												
Mass moment of inertia (relates to the drive) Clamping hub diameter [mm]	C	14	J_1	kgcm ²	0.31	0.31	0.31	0.31	0.31	0.31	0.31	0.31	0.31	0.31	0.31
				10 ⁻³ in.lb.s ²	0.27	0.27	0.27	0.27	0.27	0.27	0.27	0.27	0.27	0.27	0.27

Please use our sizing software cymex® for a detailed sizing – www.wittenstein-cymex.com
Please consider the maximum permissible tilting moment caused by the motor M_{1KMot} – see sizing

- ^{a)} Valid for torque transmission only
- ^{b)} Valid for standard clamping hub diameter
- ^{c)} Refers to center of the output shaft or flange
- ^{d)} Please reduce input speed at higher ambient temperatures
- ^{e)} Valid for: Smooth shaft
- ¹⁾ At increased lateral forces – see glossary

Motor shaft diameter [mm]

3-stage

up to 14⁴⁾ (C)⁵⁾
clamping hub diameter

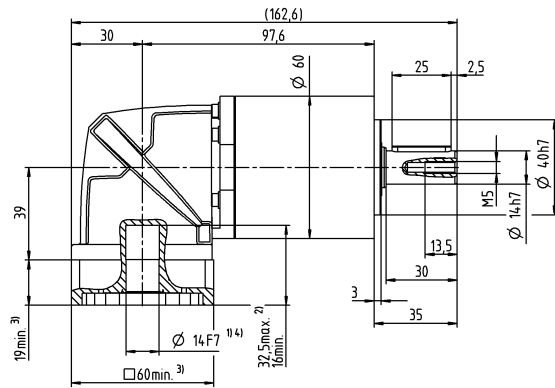
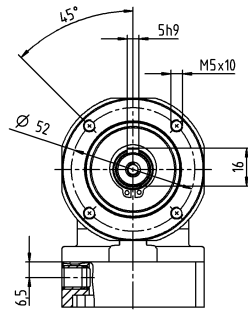

Bevel Gearboxes
Basic Line

Other output variants

Smooth shaft

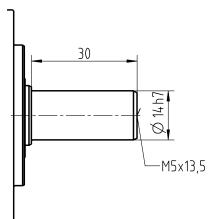

Non-tolerated dimensions are nominal dimensions

¹⁾ Check motor shaft fit

²⁾ Min. / Max. permissible motor shaft length

Longer motor shafts are possible, please contact alpha

³⁾ The dimensions depend on the motor

⁴⁾ Smaller motor shaft diameter is compensated

by a bushing with a minimum wall thickness of 1 mm

⁵⁾ Standard clamping hub diameter

CPK 025 MF 2-stage

			2-stage						
Ratio	i		3	4	5	7	8	10	
Max. torque ^{a) b) e)}	T_{2a}	Nm	60	80	100	140	144	144	
		in.lb	531	708	885	1239	1275	1275	
Max. acceleration torque ^{b)} (max. 1000 cycles per hour)	T_{2B}	Nm	35	47	58	82	90	90	
		in.lb	310	416	513	726	797	797	
Emergency stop torque ^{a) b) e)} (permitted 1000 times during the service life of the gearbox)	T_{2Not}	Nm	90	120	150	187	187	187	
		in.lb	797	1062	1328	1655	1655	1655	
Permitted average input speed ^{d)} (at T_{2a} and 20 °C ambient temperature)	n_{1N}	rpm	3000	3000	3000	3000	3000	3000	
Max. input speed	n_{1Max}	rpm	5000	5000	5000	5000	5000	5000	
Mean no load running torque ^{b)} (at $n_1=3000$ rpm and 20 °C gearbox temperature)	T_{012}	Nm	0.98	0.98	0.98	0.98	0.98	0.98	
		in.lb	8.7	8.7	8.7	8.7	8.7	8.7	
Max. backlash	j_t	arcmin	≤ 17						
Torsional rigidity ^{b)}	C_{t21}	Nm/arcmin	4.5	4.5	4.5	4.5	4.5	4.5	
		in.lb/arcmin	40	40	40	40	40	40	
Max. axial force ^{c)}	F_{2AMax}	N	1600						
		lb _f	360						
Max. lateral force ^{c)}	F_{2QMMax}	N	1200						
		lb _f	270						
Max. tilting moment	M_{2KMMax}	Nm	54						
		in.lb	478						
Efficiency at full load	η	%	95						
Service life	L_h	h	> 20000						
Weight (incl. standard adapter plate)	m	kg	4.2						
		lb _m	9.3						
Operating noise (at reference ratio and reference speed – ratio-specific values available in cymex®)	L_{PA}	dB(A)	≤ 73						
Max. permitted housing temperature		°C	+90						
		°F	+194						
Ambient temperature		°C	0 to +40						
		°F	+32 to +104						
Lubrication			Lubricated for life						
Direction of rotation			In- and output same direction						
Protection class			IP 64						
Elastomer coupling (recommended product type – validate sizing with cymex®)			ELC-0060BA020.000-X						
Bore diameter of coupling on the application side		mm	X = 012.000 - 032.000						
Mass moment of inertia (relates to the drive) Clamping hub diameter [mm]	E 19	J_1	kgcm ²	0.86	0.86	0.86	0.86	0.86	0.86
			10 ⁻³ in.lb.s ²	0.76	0.76	0.76	0.76	0.76	0.76

Please use our sizing software cymex® for a detailed sizing – www.wittenstein-cymex.com
Please consider the maximum permissible tilting moment caused by the motor M_{1KMot} – see sizing

- ^{a)} Valid for torque transmission only
- ^{b)} Valid for standard clamping hub diameter
- ^{c)} Refers to center of the output shaft or flange
- ^{d)} Please reduce input speed at higher ambient temperatures
- ^{e)} Valid for: Smooth shaft

Motor shaft diameter [mm]

2-stage

up to 19⁴⁾ (E)⁵⁾
clamping hub
diameter

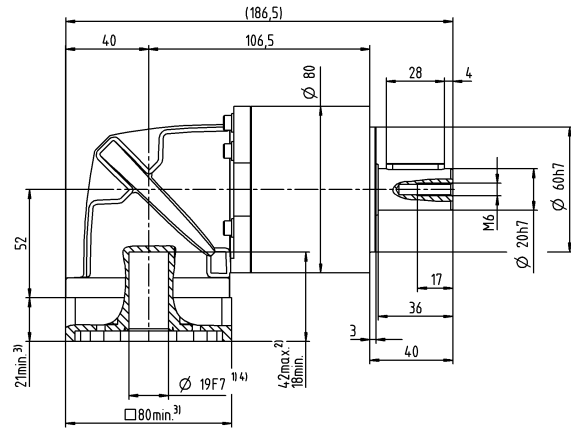
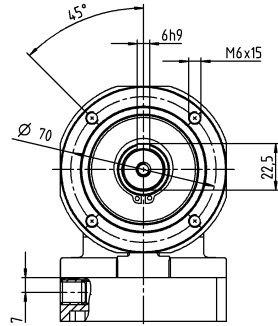

Bevel Gearboxes
Basic Line

Other output variants

Smooth shaft

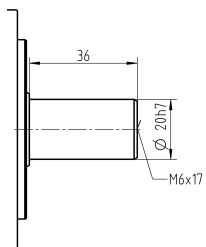

Non-tolerated dimensions are nominal dimensions

¹⁾ Check motor shaft fit

²⁾ Min. / Max. permissible motor shaft length

Longer motor shafts are possible, please contact alpha

³⁾ The dimensions depend on the motor

⁴⁾ Smaller motor shaft diameter is compensated

by a bushing with a minimum wall thickness of 1 mm

⁵⁾ Standard clamping hub diameter

CPK 025 MF 3-stage

			3-stage												
Ratio	i		9	12	15	16	20	25	28	30	35	40	50	70	100
Max. torque ^{a) b) e)}	T_{2a}	Nm	112	112	112	150	150	150	150	112	150	150	150	150	144
		in.lb	991	991	991	1328	1328	1328	1328	991	1328	1328	1328	1328	1328
Max. acceleration torque ^{a)} (max. 1000 cycles per hour)	T_{2B}	Nm	70	70	70	95	95	95	95	70	100	95	100	100	90
		in.lb	620	620	620	841	841	841	841	620	885	841	885	885	797
Emergency stop torque ^{a) b) e)} (permitted 1000 times during the service life of the gearbox)	T_{2Not}	Nm	187	187	187	187	187	187	187	187	187	187	187	187	187
		in.lb	1655	1655	1655	1655	1655	1655	1655	1655	1655	1655	1655	1655	1655
Permitted average input speed ^{d)} (at T_{2a} and 20 °C ambient temperature)	n_{1N}	rpm	3000	3000	3000	3000	3000	3000	3000	3000	3000	3000	3000	3000	3000
Max. input speed	n_{1Max}	rpm	5000	5000	5000	5000	5000	5000	5000	5000	5000	5000	5000	5000	5000
Mean no load running torque ^{b)} (at $n_1=3000$ rpm and 20 °C gearbox temperature)	T_{012}	Nm	1.1	1.1	1.1	1.1	1.1	1.1	1.1	1.1	1.1	1.1	1.1	1.1	1.1
		in.lb	9.7	9.7	9.7	9.7	9.7	9.7	9.7	9.7	9.7	9.7	9.7	9.7	9.7
Max. backlash	j_t	arcmin	≤ 18												
Torsional rigidity ^{b)}	C_{t21}	Nm/arcmin	5.9	5.9	5.9	5.9	5.9	5.9	5.9	5.9	5.9	5.9	5.9	5.9	5.9
		in.lb/arcmin	52	52	52	52	52	52	52	52	52	52	52	52	52
Max. axial force ^{c)}	F_{2AMax}	N	1600												
		lb _f	360												
Max. lateral force ^{c)}	F_{2QMax}	N	1200												
		lb _f	270												
Max. tilting moment	M_{2KMMax}	Nm	54												
		in.lb	478												
Efficiency at full load	η	%	94												
Service life	L_h	h	> 20000												
Weight (incl. standard adapter plate)	m	kg	4.5												
		lb _m	9.9												
Operating noise (at reference ratio and reference speed – ratio-specific values available in cymex®)	L_{PA}	dB(A)	≤ 73												
Max. permitted housing temperature		°C	+90												
		°F	+194												
Ambient temperature		°C	0 to +40												
		°F	+32 to +104												
Lubrication			Lubricated for life												
Direction of rotation			In- and output same direction												
Protection class			IP 64												
Elastomer coupling (recommended product type – validate sizing with cymex®)			ELC-0060BA020.000-X												
Bore diameter of coupling on the application side		mm	X = 012.000 - 032.000												
Mass moment of inertia (relates to the drive) Clamping hub diameter [mm]	E	19	J_1	kgcm ²	0.92	0.92	0.92	0.92	0.92	0.92	0.92	0.92	0.92	0.92	0.92
				10 ⁻³ in.lb.s ²	0.81	0.81	0.81	0.81	0.81	0.81	0.81	0.81	0.81	0.81	0.81

Please use our sizing software cymex® for a detailed sizing – www.wittenstein-cymex.com
Please consider the maximum permissible tilting moment caused by the motor M_{1KMot} – see sizing

- ^{a)} Valid for torque transmission only
- ^{b)} Valid for standard clamping hub diameter
- ^{c)} Refers to center of the output shaft or flange
- ^{d)} Please reduce input speed at higher ambient temperatures
- ^{e)} Valid for: Smooth shaft

Motor shaft diameter [mm]

3-stage

up to 19⁴⁾ (E)⁵⁾
clamping hub
diameter

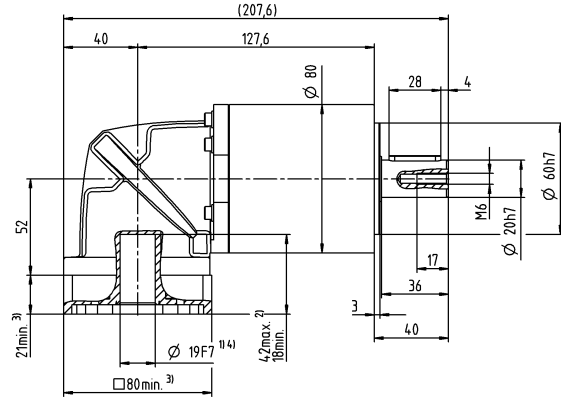
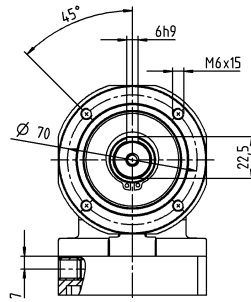

Bevel Gearboxes
Basic Line

Other output variants

Smooth shaft

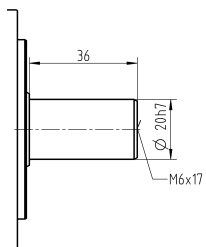

Non-tolerated dimensions are nominal dimensions

¹⁾ Check motor shaft fit

²⁾ Min. / Max. permissible motor shaft length

Longer motor shafts are possible, please contact alpha

³⁾ The dimensions depend on the motor

⁴⁾ Smaller motor shaft diameter is compensated by a bushing with a minimum wall thickness of 1 mm

⁵⁾ Standard clamping hub diameter

CPK 035 MF 2-stage

			2-stage						
Ratio	i		3	4	5	7	8	10	
Max. torque ^{a) b) e)}	T_{2a}	Nm	150	200	250	272	272	272	
		in.lb	1328	1770	2213	2407	2407	2407	
Max. acceleration torque ^{b)} (max. 1000 cycles per hour)	T_{2B}	Nm	93	124	155	217	220	220	
		in.lb	823	1097	1372	1921	1947	1947	
Emergency stop torque ^{a) b) e)} (permitted 1000 times during the service life of the gearbox)	T_{2Not}	Nm	238	318	397	480	477	480	
		in.lb	2106	2815	3514	4248	4222	4248	
Permitted average input speed ^{d)} (at T_{2a} and 20 °C ambient temperature)	n_{1N}	rpm	2000	2000	2000	2000	2000	2000	
Max. input speed	n_{1Max}	rpm	4500	4500	4500	4500	4500	4500	
Mean no load running torque ^{b)} (at $n_1=3000$ rpm and 20 °C gearbox temperature)	T_{012}	Nm	3.5	3.5	3.5	3.5	3.5	3.5	
		in.lb	31	31	31	31	31	31	
Max. backlash	j_t	arcmin	≤ 15						
Torsional rigidity ^{b)}	C_{t21}	Nm/arcmin	13	13	13	13	13	13	
		in.lb/arcmin	115	115	115	115	115	115	
Max. axial force ^{c)}	F_{2AMax}	N	2500						
		lb _f	563						
Max. lateral force ^{c)}	F_{2OMax}	N	1750						
		lb _f	394						
Max. tilting moment	M_{2KMMax}	Nm	98						
		in.lb	867						
Efficiency at full load	η	%	95						
Service life	L_h	h	> 20000						
Weight (incl. standard adapter plate)	m	kg	8.8						
		lb _m	19						
Operating noise (at reference ratio and reference speed – ratio-specific values available in cymex®)	L_{PA}	dB(A)	≤ 74						
Max. permitted housing temperature		°C	+90						
		°F	+194						
Ambient temperature		°C	0 to +40						
		°F	+32 to +104						
Lubrication			Lubricated for life						
Direction of rotation			In- and output same direction						
Protection class			IP 64						
Elastomer coupling (recommended product type – validate sizing with cymex®)			ELC-0150BA025.000-X						
Bore diameter of coupling on the application side		mm	X = 019.000 - 036.000						
Mass moment of inertia (relates to the drive) Clamping hub diameter [mm]	H 28	J_1	kgcm ²	6.1	6.1	6.1	6.1	6.1	6.1
			10 ⁻³ in.lb.s ²	5.4	5.4	5.4	5.4	5.4	5.4

Please use our sizing software cymex® for a detailed sizing – www.wittenstein-cymex.com
Please consider the maximum permissible tilting moment caused by the motor M_{1KMot} – see sizing

- ^{a)} Valid for torque transmission only
- ^{b)} Valid for standard clamping hub diameter
- ^{c)} Refers to center of the output shaft or flange
- ^{d)} Please reduce input speed at higher ambient temperatures
- ^{e)} Valid for: Smooth shaft

Motor shaft diameter [mm]

2-stage

up to 28⁴⁾ (H)⁵⁾
clamping hub
diameter

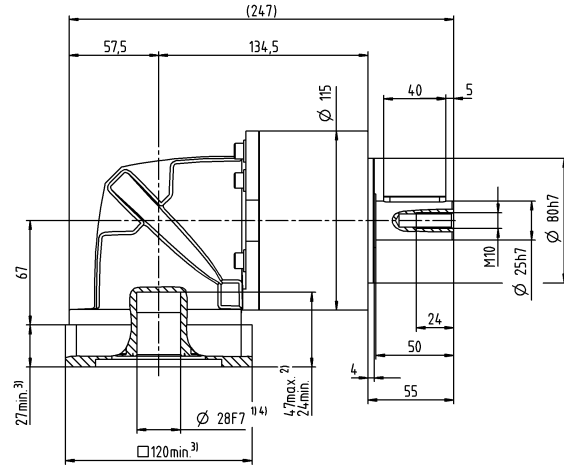
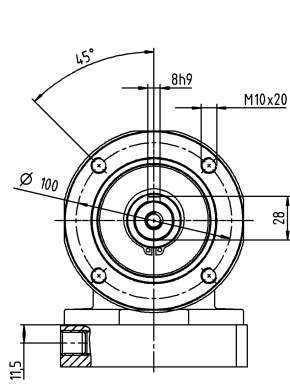

Bevel Gearboxes
Basic Line

Other output variants

Smooth shaft

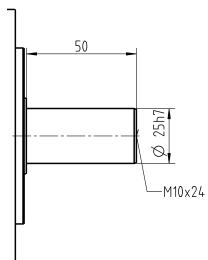

Non-tolerated dimensions are nominal dimensions

¹⁾ Check motor shaft fit

²⁾ Min. / Max. permissible motor shaft length

Longer motor shafts are possible, please contact alpha

³⁾ The dimensions depend on the motor

⁴⁾ Smaller motor shaft diameter is compensated

by a bushing with a minimum wall thickness of 1 mm

⁵⁾ Standard clamping hub diameter

CPK 035 MF 3-stage

			3-stage														
Ratio	i		9	12	15	16	20	25	28	30	32	35	40	50	64	70	100
Max. torque ^{a) b) e)}	T_{2a}	Nm	272	272	272	272	272	272	272	272	272	272	272	272	272	272	272
		in.lb	2407	2407	2407	2407	2407	2407	2407	2407	2407	2407	2407	2407	2407	2407	2407
Max. acceleration torque ^{a)} (max. 1000 cycles per hour)	T_{2B}	Nm	175	175	175	255	255	250	255	175	255	250	255	250	220	250	220
		in.lb	1549	1549	1549	2257	2257	2213	2257	1549	2257	2213	2257	2213	1947	2213	1947
Emergency stop torque ^{a) b) e)} (permitted 1000 times during the service life of the gearbox)	T_{2Not}	Nm	480	480	480	480	480	480	480	315	480	480	480	480	477	480	480
		in.lb	4248	4248	4248	4248	4248	4248	4248	2788	4248	4248	4248	4248	4222	4248	4248
Permitted average input speed ^{d)} (at T_{2a} and 20 °C ambient temperature)	n_{1N}	rpm	2000	2000	2000	2000	2000	2000	2000	2000	2000	2000	2000	2000	2000	2000	2000
Max. input speed	n_{1Max}	rpm	4500	4500	4500	4500	4500	4500	4500	4500	4500	4500	4500	4500	4500	4500	4500
Mean no load running torque ^{b)} (at $n_1=3000$ rpm and 20 °C gearbox temperature)	T_{012}	Nm	3.8	3.8	3.8	3.8	3.8	3.8	3.8	3.8	3.8	3.8	3.8	3.8	3.8	3.8	3.8
		in.lb	34	34	34	34	34	34	34	34	34	34	34	34	34	34	34
Max. backlash	j_t	arcmin	≤ 17														
Torsional rigidity ^{b)}	C_{121}	Nm/arcmin	16	16	16	16	16	16	16	16	16	16	16	16	16	16	16
		in.lb/arcmin	142	142	142	142	142	142	142	142	142	142	142	142	142	142	142
Max. axial force ^{c)}	F_{2AMax}	N	2500														
		lb _f	563														
Max. lateral force ^{c)}	F_{2OMax}	N	1750														
		lb _f	394														
Max. tilting moment	M_{2KMMax}	Nm	98														
		in.lb	867														
Efficiency at full load	η	%	94														
Service life	L_n	h	> 20000														
Weight (incl. standard adapter plate)	m	kg	10														
		lb _m	22														
Operating noise (at reference ratio and reference speed – ratio-specific values available in cymex®)	L_{PA}	dB(A)	≤ 74														
Max. permitted housing temperature		°C	+90														
		°F	+194														
Ambient temperature		°C	0 to +40														
		°F	+32 to +104														
Lubrication			Lubricated for life														
Direction of rotation			In- and output same direction														
Protection class			IP 64														
Elastomer coupling (recommended product type – validate sizing with cymex®)			ELC-0150BA025.000-X														
Bore diameter of coupling on the application side		mm	X = 019.000 - 036.000														
Mass moment of inertia (relates to the drive) Clamping hub diameter [mm]	H	28	J_1	kgcm ²	6.3	6.3	6.3	6.3	6.3	6.3	6.3	6.3	6.3	6.3	6.3	6.3	6.3
				10 ⁻³ in.lb.s ²	5.6	5.6	5.6	5.6	5.6	5.6	5.6	5.6	5.6	5.6	5.6	5.6	5.6

Please use our sizing software cymex® for a detailed sizing – www.wittenstein-cymex.com
Please consider the maximum permissible tilting moment caused by the motor M_{1KMot} – see sizing

- ^{a)} Valid for torque transmission only
- ^{b)} Valid for standard clamping hub diameter
- ^{c)} Refers to center of the output shaft or flange
- ^{d)} Please reduce input speed at higher ambient temperatures
- ^{e)} Valid for: Smooth shaft

Motor shaft diameter [mm]

3-stage

up to 28⁴⁾ (H)⁵⁾
clamping hub
diameter

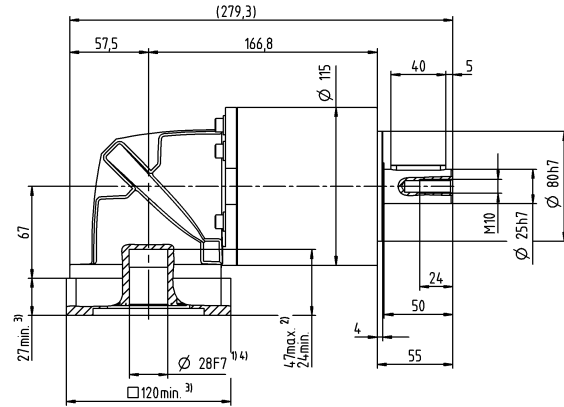
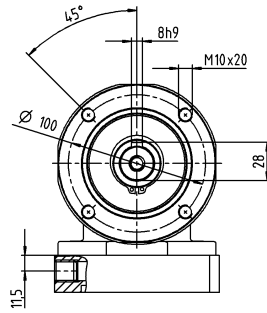

Bevel Gearboxes
Basic Line

Other output variants

Smooth shaft

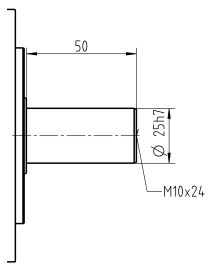

Non-tolerated dimensions are nominal dimensions

¹⁾ Check motor shaft fit

²⁾ Min. / Max. permissible motor shaft length

Longer motor shafts are possible, please contact alpha

³⁾ The dimensions depend on the motor

⁴⁾ Smaller motor shaft diameter is compensated

by a bushing with a minimum wall thickness of 1 mm

⁵⁾ Standard clamping hub diameter

CPK 045 MF 3-stage

			3-stage			
Ratio	i		25	50	100	
Max. torque ^{a) b) e)}	T_{2a}	Nm	700	700	640	
		in.lb	6196	6196	5665	
Max. acceleration torque ^{e)} (max. 1000 cycles per hour)	T_{2B}	Nm	500	500	400	
		in.lb	4425	4425	3540	
Emergency stop torque ^{a) b) e)} (permitted 1000 times during the service life of the gearbox)	T_{2Not}	Nm	1000	1000	1000	
		in.lb	8851	8851	8851	
Permitted average input speed ^{d)} (at T_{2a} and 20 °C ambient temperature)	n_{1N}	rpm	2000	2000	2000	
Max. input speed	n_{1Max}	rpm	4500	4500	4500	
Mean no load running torque ^{b)} (at $n_1=3000$ rpm and 20 °C gearbox temperature)	T_{012}	Nm	3.6	3.6	3.6	
		in.lb	32	32	32	
Max. backlash	j_t	arcmin	≤ 16			
Torsional rigidity ^{b)}	C_{121}	Nm/arcmin	54	54	54	
		in.lb/arcmin	478	478	478	
Max. axial force ^{c)}	F_{2AMax}	N	6000			
		lb _f	1350			
Max. lateral force ^{c)}	F_{2QMMax}	N	8000			
		lb _f	1800			
Max. tilting moment	M_{2KMMax}	Nm	704			
		in.lb	6231			
Efficiency at full load	η	%	94			
Service life	L_h	h	> 20000			
Weight (incl. standard adapter plate)	m	kg	21			
		lb _m	46			
Operating noise (at reference ratio and reference speed – ratio-specific values available in cymex®)	L_{PA}	dB(A)	≤ 78			
Max. permitted housing temperature		°C	+90			
		°F	+194			
Ambient temperature		°C	0 to +40			
		°F	+32 to +104			
Lubrication			Lubricated for life			
Direction of rotation			In- and output same direction			
Protection class			IP 64			
Elastomer coupling (recommended product type – validate sizing with cymex®)			ELC-0300BA040.000-X			
Bore diameter of coupling on the application side		mm	X = 020.000 - 045.000			
Mass moment of inertia (relates to the drive) Clamping hub diameter [mm]	H 28	J_1	kgcm ²	6.8	6.8	6.8
			10 ⁻³ in.lb.s ²	6	6	6

Please use our sizing software cymex® for a detailed sizing – www.wittenstein-cymex.com
Please consider the maximum permissible tilting moment caused by the motor M_{1KMot} – see sizing

- ^{a)} Valid for torque transmission only
- ^{b)} Valid for standard clamping hub diameter
- ^{c)} Refers to center of the output shaft or flange
- ^{d)} Please reduce input speed at higher ambient temperatures
- ^{e)} Valid for: Smooth shaft

Motor shaft diameter [mm]

3-stage

up to 28⁴⁾ (H)⁵⁾
clamping hub diameter

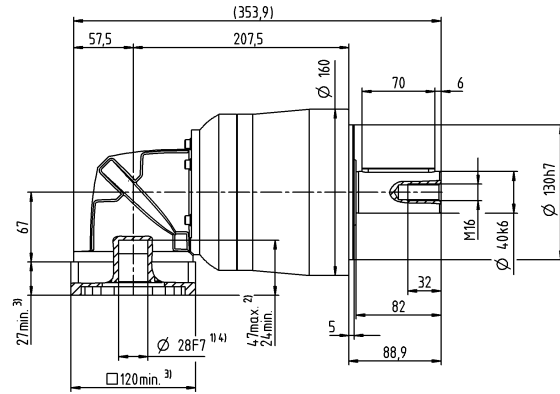
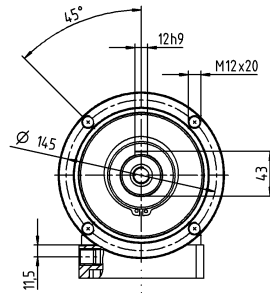

Bevel Gearboxes
Basic Line

Other output variants

Smooth shaft

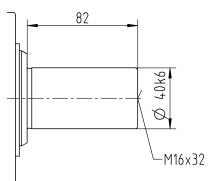

Non-tolerated dimensions are nominal dimensions

¹⁾ Check motor shaft fit

²⁾ Min. / Max. permissible motor shaft length

Longer motor shafts are possible, please contact alpha

³⁾ The dimensions depend on the motor

⁴⁾ Smaller motor shaft diameter is compensated

by a bushing with a minimum wall thickness of 1 mm

⁵⁾ Standard clamping hub diameter

CPSK 015 MF 2-stage

			2-stage						
Ratio	i		3	4	5	7	8	10	
Max. torque ^{a) b) e)}	T_{2a}	Nm	33	44	55	58	56	56	
		in.lb	292	389	487	513	496	496	
Max. acceleration torque ^{b)} (max. 1000 cycles per hour)	T_{2B}	Nm	16	21	27	37	35	35	
		in.lb	142	186	239	327	310	310	
Emergency stop torque ^{a) b) e)} (permitted 1000 times during the service life of the gearbox)	T_{2Not}	Nm	41	55	69	75	75	75	
		in.lb	363	487	611	664	664	664	
Permitted average input speed ^{d)} (at T_{2a} and 20 °C ambient temperature)	n_{1N}	rpm	3300	3300	3300	3300	3300	3300	
Max. input speed	n_{1Max}	rpm	5000	5000	5000	5000	5000	5000	
Mean no load running torque ^{b)} (at $n_1=3000$ rpm and 20 °C gearbox temperature)	T_{012}	Nm	0.55	0.55	0.55	0.55	0.55	0.55	
		in.lb	4.9	4.9	4.9	4.9	4.9	4.9	
Max. backlash	j_t	arcmin	≤ 17						
Torsional rigidity ^{b)}	C_{t21}	Nm/arcmin	1.7	1.7	1.7	1.7	1.7	1.7	
		in.lb/arcmin	15	15	15	15	15	15	
Max. axial force ^{c)}	F_{2AMax}	N	750						
		lb _f	169						
Max. lateral force ^{c)}	F_{2QMax}	N	500						
		lb _f	113						
Max. tilting moment	M_{2KMMax}	Nm	17						
		in.lb	150						
Efficiency at full load	η	%	95						
Service life	L_h	h	> 20000						
Weight (incl. standard adapter plate)	m	kg	1.6						
		lb _m	3.5						
Operating noise (at reference ratio and reference speed – ratio-specific values available in cymex®)	L_{PA}	dB(A)	≤ 70						
Max. permitted housing temperature		°C	+90						
		°F	+194						
Ambient temperature		°C	0 to +40						
		°F	+32 to +104						
Lubrication			Lubricated for life						
Direction of rotation			In- and output same direction						
Protection class			IP 64						
Elastomer coupling (recommended product type – validate sizing with cymex®)			ELC-0020BA014.000-X						
Bore diameter of coupling on the application side		mm	X = 008.000 - 025.000						
Mass moment of inertia (relates to the drive) Clamping hub diameter [mm]	C 14	J_1	kgcm ²	0.3	0.3	0.3	0.3	0.3	0.3
			10 ⁻³ in.lb.s ²	0.27	0.27	0.27	0.27	0.27	0.27

Please use our sizing software cymex® for a detailed sizing – www.wittenstein-cymex.com
Please consider the maximum permissible tilting moment caused by the motor M_{1KMot} – see sizing

- ^{a)} Valid for torque transmission only
- ^{b)} Valid for standard clamping hub diameter
- ^{c)} Refers to center of the output shaft or flange
- ^{d)} Please reduce input speed at higher ambient temperatures
- ^{e)} Valid for: Smooth shaft

Motor shaft diameter [mm]

2-stage

up to 14⁴⁾ (C)⁵⁾
clamping hub
diameter

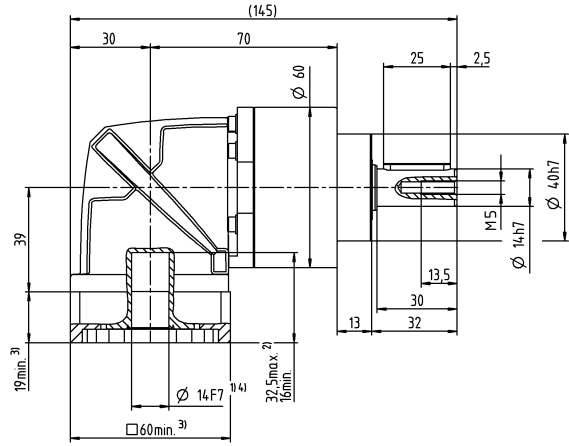
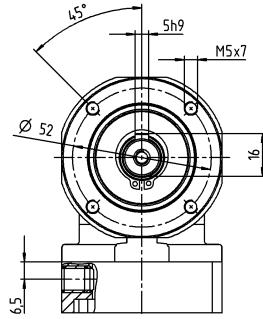

Bevel Gearboxes
Basic Line

Other output variants

Smooth shaft

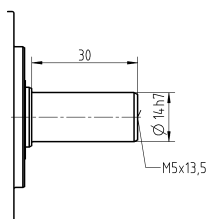

Replaceable B5 output flange

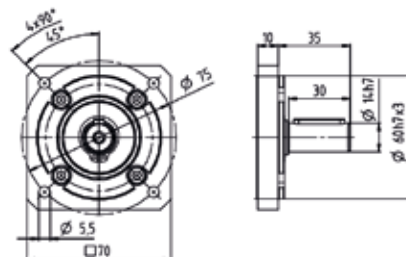

Non-tolerated dimensions are nominal dimensions

¹⁾ Check motor shaft fit

²⁾ Min. / Max. permissible motor shaft length

Longer motor shafts are possible, please contact alpha

³⁾ The dimensions depend on the motor

⁴⁾ Smaller motor shaft diameter is compensated

by a bushing with a minimum wall thickness of 1 mm

⁵⁾ Standard clamping hub diameter

CPSK 015 MF 3-stage

			3-stage												
Ratio	i		9	12	15	16	20	25	28	30	35	40	50	70	100
Max. torque ^{a) b) e)}	T_{2a}	Nm	48	48	48	56	56	58	56	48	58	56	58	58	56
		in.lb	425	425	425	496	496	513	496	425	513	496	513	513	496
Max. acceleration torque ^{a)} (max. 1000 cycles per hour)	T_{2B}	Nm	30	30	30	35	35	40	35	30	40	35	40	40	35
		in.lb	266	266	266	310	310	354	310	266	354	310	354	354	310
Emergency stop torque ^{a) b) e)} (permitted 1000 times during the service life of the gearbox)	T_{2Not}	Nm	75	75	75	75	75	75	75	75	75	75	75	75	75
		in.lb	664	664	664	664	664	664	664	664	664	664	664	664	664
Permitted average input speed ^{d)} (at T_{2a} and 20 °C ambient temperature)	n_{1N}	rpm	3300	3300	3300	3300	3300	3300	3300	3300	3300	3300	3300	3300	3300
Max. input speed	n_{1Max}	rpm	5000	5000	5000	5000	5000	5000	5000	5000	5000	5000	5000	5000	5000
Mean no load running torque ^{b)} (at $n_1=3000$ rpm and 20 °C gearbox temperature)	T_{012}	Nm	0.63	0.63	0.63	0.63	0.63	0.63	0.63	0.63	0.63	0.63	0.63	0.63	0.63
		in.lb	5.6	5.6	5.6	5.6	5.6	5.6	5.6	5.6	5.6	5.6	5.6	5.6	5.6
Max. backlash	j_i	arcmin	≤ 17												
Torsional rigidity ^{b)}	C_{221}	Nm/arcmin	2.1	2.1	2.1	2.1	2.1	2.1	2.1	2.1	2.1	2.1	2.1	2.1	2.1
		in.lb/arcmin	19	19	19	19	19	19	19	19	19	19	19	19	19
Max. axial force ^{c)}	F_{2AMax}	N	750												
		lb _f	169												
Max. lateral force ^{c)}	F_{2QMax}	N	500												
		lb _f	113												
Max. tilting moment	M_{2KMMax}	Nm	17												
		in.lb	150												
Efficiency at full load	η	%	94												
Service life	L_n	h	> 20000												
Weight (incl. standard adapter plate)	m	kg	1.8												
		lb _m	4												
Operating noise (at reference ratio and reference speed – ratio-specific values available in cymex®)	L_{PA}	dB(A)	≤ 70												
Max. permitted housing temperature		°C	+90												
		°F	+194												
Ambient temperature		°C	0 to +40												
		°F	+32 to +104												
Lubrication			Lubricated for life												
Direction of rotation			In- and output same direction												
Protection class			IP 64												
Elastomer coupling (recommended product type – validate sizing with cymex®)			ELC-0020BA014.000-X												
Bore diameter of coupling on the application side		mm	X = 008.000 - 025.000												
Mass moment of inertia (relates to the drive) Clamping hub diameter [mm]	C	14	J_1	kgcm ²	0.31	0.31	0.31	0.31	0.31	0.31	0.31	0.31	0.31	0.31	0.31
				10 ⁻³ in.lb.s ²	0.27	0.27	0.27	0.27	0.27	0.27	0.27	0.27	0.27	0.27	0.27

Please use our sizing software cymex® for a detailed sizing – www.wittenstein-cymex.com
Please consider the maximum permissible tilting moment caused by the motor M_{1KMot} – see sizing

- ^{a)} Valid for torque transmission only
- ^{b)} Valid for standard clamping hub diameter
- ^{c)} Refers to center of the output shaft or flange
- ^{d)} Please reduce input speed at higher ambient temperatures
- ^{e)} Valid for: Smooth shaft

Motor shaft diameter [mm]

3-stage

up to 14⁴⁾ (C)⁵⁾
clamping hub
diameter

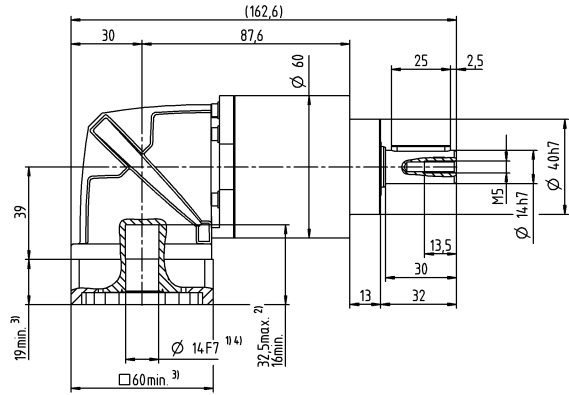
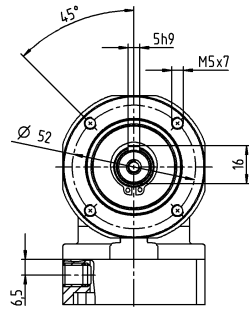

Bevel Gearboxes
Basic Line

Other output variants

Smooth shaft

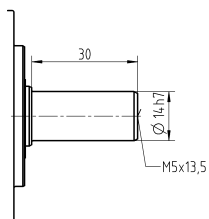

Replaceable B5 output flange

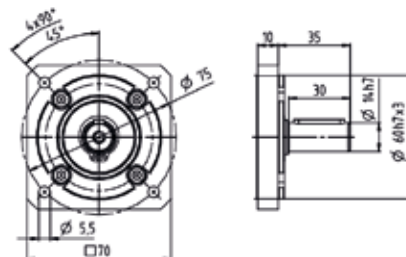

Non-tolerated dimensions are nominal dimensions

¹⁾ Check motor shaft fit

²⁾ Min. / Max. permissible motor shaft length

Longer motor shafts are possible, please contact alpha

³⁾ The dimensions depend on the motor

⁴⁾ Smaller motor shaft diameter is compensated by a bushing with a minimum wall thickness of 1 mm

⁵⁾ Standard clamping hub diameter

CPSK 025 MF 2-stage

			2-stage						
Ratio	i		3	4	5	7	8	10	
Max. torque ^{a) b) e)}	T_{2a}	Nm	60	80	100	140	144	144	
		in.lb	531	708	885	1239	1275	1275	
Max. acceleration torque ^{b)} (max. 1000 cycles per hour)	T_{2B}	Nm	35	47	58	82	90	90	
		in.lb	310	416	513	726	797	797	
Emergency stop torque ^{a) b) e)} (permitted 1000 times during the service life of the gearbox)	T_{2Not}	Nm	90	120	150	187	187	187	
		in.lb	797	1062	1328	1655	1655	1655	
Permitted average input speed ^{d)} (at T_{2a} and 20 °C ambient temperature)	n_{1N}	rpm	3000	3000	3000	3000	3000	3000	
Max. input speed	n_{1Max}	rpm	5000	5000	5000	5000	5000	5000	
Mean no load running torque ^{b)} (at $n_1=3000$ rpm and 20 °C gearbox temperature)	T_{012}	Nm	0.98	0.98	0.98	0.98	0.98	0.98	
		in.lb	8.7	8.7	8.7	8.7	8.7	8.7	
Max. backlash	j_t	arcmin	≤ 17						
Torsional rigidity ^{b)}	C_{t21}	Nm/arcmin	4.5	4.5	4.5	4.5	4.5	4.5	
		in.lb/arcmin	40	40	40	40	40	40	
Max. axial force ^{c)}	F_{2AMax}	N	1600						
		lb _f	360						
Max. lateral force ^{c)}	F_{2OMax}	N	1200						
		lb _f	270						
Max. tilting moment	M_{2KMMax}	Nm	54						
		in.lb	478						
Efficiency at full load	η	%	95						
Service life	L_n	h	> 20000						
Weight (incl. standard adapter plate)	m	kg	4.2						
		lb _m	9.3						
Operating noise (at reference ratio and reference speed – ratio-specific values available in cymex®)	L_{PA}	dB(A)	≤ 73						
Max. permitted housing temperature		°C	+90						
		°F	+194						
Ambient temperature		°C	0 to +40						
		°F	+32 to +104						
Lubrication			Lubricated for life						
Direction of rotation			In- and output same direction						
Protection class			IP 64						
Elastomer coupling (recommended product type – validate sizing with cymex®)			ELC-0060BA020.000-X						
Bore diameter of coupling on the application side		mm	X = 012.000 - 032.000						
Mass moment of inertia (relates to the drive) Clamping hub diameter [mm]	E 19	J_1	kgcm ²	0.86	0.86	0.86	0.86	0.86	0.86
			10 ⁻³ in.lb.s ²	0.76	0.76	0.76	0.76	0.76	0.76

Please use our sizing software cymex® for a detailed sizing – www.wittenstein-cymex.com
Please consider the maximum permissible tilting moment caused by the motor M_{1KMot} – see sizing

^{a)} Valid for torque transmission only

^{b)} Valid for standard clamping hub diameter

^{c)} Refers to center of the output shaft or flange

^{d)} Please reduce input speed at higher ambient temperatures

^{e)} Valid for: Smooth shaft

Motor shaft diameter [mm]

2-stage

up to 19⁴⁾ (E)⁵⁾
clamping hub
diameter

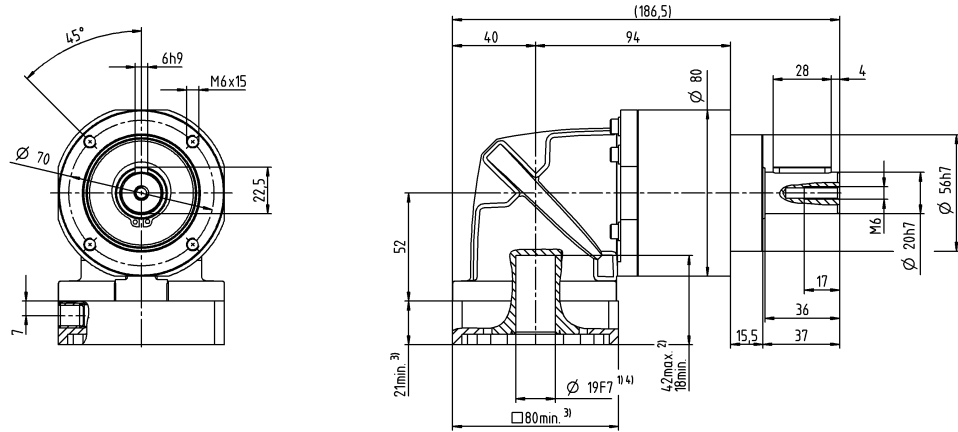

Bevel Gearboxes
Basic Line

Other output variants

Smooth shaft

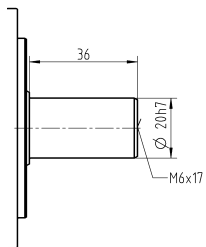

Replaceable B5 output flange

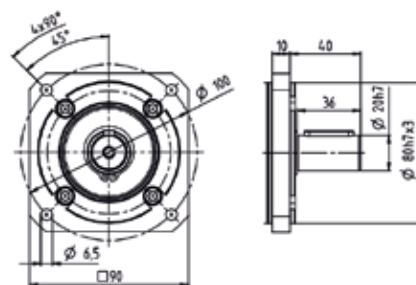

Non-tolerated dimensions are nominal dimensions

¹⁾ Check motor shaft fit

²⁾ Min. / Max. permissible motor shaft length

Longer motor shafts are possible, please contact alpha

³⁾ The dimensions depend on the motor

⁴⁾ Smaller motor shaft diameter is compensated

by a bushing with a minimum wall thickness of 1 mm

⁵⁾ Standard clamping hub diameter

CPSK 025 MF 3-stage

			3-stage												
Ratio	i		9	12	15	16	20	25	28	30	35	40	50	70	100
Max. torque ^{a) b) e)}	T_{2a}	Nm	112	112	112	150	150	150	150	112	150	150	150	150	144
		in.lb	991	991	991	1328	1328	1328	1328	991	1328	1328	1328	1328	1328
Max. acceleration torque ^{a)} (max. 1000 cycles per hour)	T_{2B}	Nm	70	70	70	95	95	95	95	70	100	95	100	100	90
		in.lb	620	620	620	841	841	841	841	620	885	841	885	885	797
Emergency stop torque ^{a) b) e)} (permitted 1000 times during the service life of the gearbox)	T_{2Not}	Nm	187	187	187	187	187	187	187	187	187	187	187	187	187
		in.lb	1655	1655	1655	1655	1655	1655	1655	1655	1655	1655	1655	1655	1655
Permitted average input speed ^{d)} (at T_{2a} and 20 °C ambient temperature)	n_{1N}	rpm	3000	3000	3000	3000	3000	3000	3000	3000	3000	3000	3000	3000	3000
Max. input speed	n_{1Max}	rpm	5000	5000	5000	5000	5000	5000	5000	5000	5000	5000	5000	5000	5000
Mean no load running torque ^{b)} (at $n_1=3000$ rpm and 20 °C gearbox temperature)	T_{012}	Nm	1.1	1.1	1.1	1.1	1.1	1.1	1.1	1.1	1.1	1.1	1.1	1.1	1.1
		in.lb	9.7	9.7	9.7	9.7	9.7	9.7	9.7	9.7	9.7	9.7	9.7	9.7	9.7
Max. backlash	j_t	arcmin	≤ 18												
Torsional rigidity ^{b)}	C_{t21}	Nm/arcmin	5.9	5.9	5.9	5.9	5.9	5.9	5.9	5.9	5.9	5.9	5.9	5.9	5.9
		in.lb/arcmin	52	52	52	52	52	52	52	52	52	52	52	52	52
Max. axial force ^{c)}	F_{2AMax}	N	1600												
		lb _f	360												
Max. lateral force ^{c)}	F_{2QMax}	N	1200												
		lb _f	270												
Max. tilting moment	M_{2KMMax}	Nm	54												
		in.lb	478												
Efficiency at full load	η	%	94												
Service life	L_h	h	> 20000												
Weight (incl. standard adapter plate)	m	kg	4.5												
		lb _m	9.9												
Operating noise (at reference ratio and reference speed – ratio-specific values available in cymex®)	L_{PA}	dB(A)	≤ 73												
Max. permitted housing temperature		°C	+90												
		°F	+194												
Ambient temperature		°C	0 to +40												
		°F	+32 to +104												
Lubrication			Lubricated for life												
Direction of rotation			In- and output same direction												
Protection class			IP 64												
Elastomer coupling (recommended product type – validate sizing with cymex®)			ELC-0060BA020.000-X												
Bore diameter of coupling on the application side		mm	X = 012.000 - 032.000												
Mass moment of inertia (relates to the drive) Clamping hub diameter [mm]	E	19	J_1	kgcm ²	0.92	0.92	0.92	0.92	0.92	0.92	0.92	0.92	0.92	0.92	0.92
				10 ⁻³ in.lb.s ²	0.81	0.81	0.81	0.81	0.81	0.81	0.81	0.81	0.81	0.81	0.81

Please use our sizing software cymex® for a detailed sizing – www.wittenstein-cymex.com
Please consider the maximum permissible tilting moment caused by the motor M_{1KMot} – see sizing

- ^{a)} Valid for torque transmission only
- ^{b)} Valid for standard clamping hub diameter
- ^{c)} Refers to center of the output shaft or flange
- ^{d)} Please reduce input speed at higher ambient temperatures
- ^{e)} Valid for: Smooth shaft

Motor shaft diameter [mm]

3-stage

up to 19⁴⁾ (E)⁵⁾
clamping hub diameter

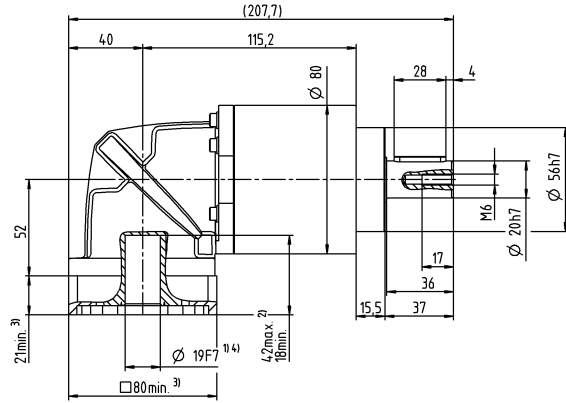
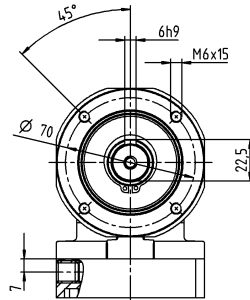

Bevel Gearboxes
Basic Line

Other output variants

Smooth shaft

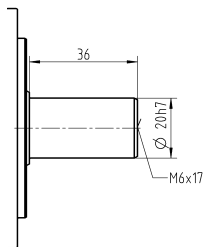

Replaceable B5 output flange

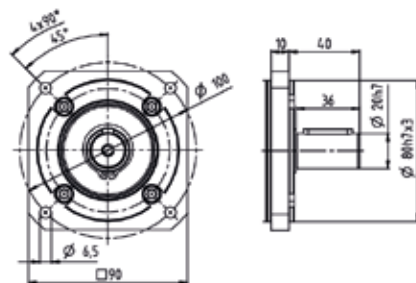

Non-tolerated dimensions are nominal dimensions

- ¹⁾ Check motor shaft fit
- ²⁾ Min. / Max. permissible motor shaft length
Longer motor shafts are possible, please contact alpha
- ³⁾ The dimensions depend on the motor
- ⁴⁾ Smaller motor shaft diameter is compensated by a bushing with a minimum wall thickness of 1 mm
- ⁵⁾ Standard clamping hub diameter

CPSK 035 MF 2-stage

			2-stage						
Ratio	i		3	4	5	7	8	10	
Max. torque ^{a) b) e)}	T_{2a}	Nm	150	200	250	272	272	272	
		in.lb	1328	1770	2213	2407	2407	2407	
Max. acceleration torque ^{a)} (max. 1000 cycles per hour)	T_{2B}	Nm	93	124	155	217	220	220	
		in.lb	823	1097	1372	1921	1947	1947	
Emergency stop torque ^{a) b) e)} (permitted 1000 times during the service life of the gearbox)	T_{2Not}	Nm	238	318	397	480	477	480	
		in.lb	2106	2815	3514	4248	4222	4248	
Permitted average input speed ^{d)} (at T_{2a} and 20 °C ambient temperature)	n_{1N}	rpm	2000	2000	2000	2000	2000	2000	
Max. input speed	n_{1Max}	rpm	4500	4500	4500	4500	4500	4500	
Mean no load running torque ^{b)} (at $n_1=3000$ rpm and 20 °C gearbox temperature)	T_{012}	Nm	3.5	3.5	3.5	3.5	3.5	3.5	
		in.lb	31	31	31	31	31	31	
Max. backlash	j_t	arcmin	≤ 15						
Torsional rigidity ^{b)}	C_{t21}	Nm/arcmin	13	13	13	13	13	13	
		in.lb/arcmin	115	115	115	115	115	115	
Max. axial force ^{c)}	F_{2AMax}	N	2500						
		lb _f	563						
Max. lateral force ^{c)}	F_{2OMax}	N	1750						
		lb _f	394						
Max. tilting moment	M_{2KMMax}	Nm	98						
		in.lb	867						
Efficiency at full load	η	%	95						
Service life	L_h	h	> 20000						
Weight (incl. standard adapter plate)	m	kg	8.8						
		lb _m	19						
Operating noise (at reference ratio and reference speed – ratio-specific values available in cymex®)	L_{PA}	dB(A)	≤ 74						
Max. permitted housing temperature		°C	+90						
		°F	+194						
Ambient temperature		°C	0 to +40						
		°F	+32 to +104						
Lubrication			Lubricated for life						
Direction of rotation			In- and output same direction						
Protection class			IP 64						
Elastomer coupling (recommended product type – validate sizing with cymex®)			ELC-0150BA025.000-X						
Bore diameter of coupling on the application side		mm	X = 019.000 - 036.000						
Mass moment of inertia (relates to the drive) Clamping hub diameter [mm]	H 28	J_1	kgcm ²	6.1	6.1	6.1	6.1	6.1	6.1
			10 ⁻³ in.lb.s ²	5.4	5.4	5.4	5.4	5.4	5.4

Please use our sizing software cymex® for a detailed sizing – www.wittenstein-cymex.com
Please consider the maximum permissible tilting moment caused by the motor M_{1KMot} – see sizing

- ^{a)} Valid for torque transmission only
- ^{b)} Valid for standard clamping hub diameter
- ^{c)} Refers to center of the output shaft or flange
- ^{d)} Please reduce input speed at higher ambient temperatures
- ^{e)} Valid for: Smooth shaft

Motor shaft diameter [mm]

2-stage

up to 28⁴⁾ (H)⁵⁾
clamping hub
diameter

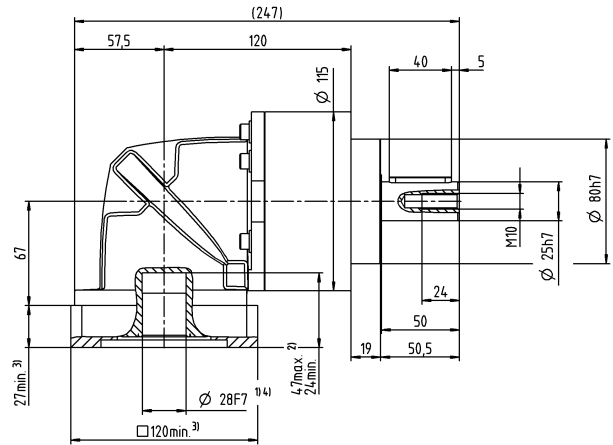
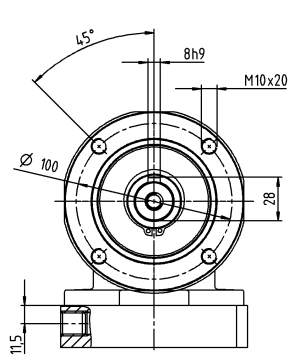

Bevel Gearboxes
Basic Line

Other output variants

Smooth shaft

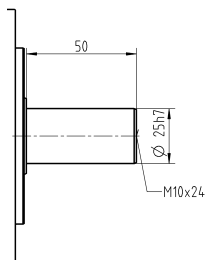

Replaceable B5 output flange

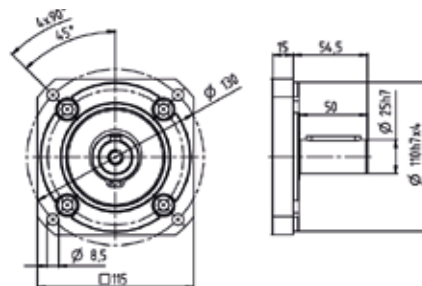

Non-tolerated dimensions are nominal dimensions

- ¹⁾ Check motor shaft fit
- ²⁾ Min. / Max. permissible motor shaft length
Longer motor shafts are possible, please contact alpha
- ³⁾ The dimensions depend on the motor
- ⁴⁾ Smaller motor shaft diameter is compensated by a bushing with a minimum wall thickness of 1 mm
- ⁵⁾ Standard clamping hub diameter

CPSK 035 MF 3-stage

			3-stage												
Ratio	i		9	12	15	16	20	25	28	30	35	40	50	70	100
Max. torque ^{a) b) e)}	T_{2a}	Nm	272	272	272	272	272	272	272	272	272	272	272	272	272
		in.lb	2407	2407	2407	2407	2407	2407	2407	2407	2407	2407	2407	2407	2407
Max. acceleration torque ^{e)} (max. 1000 cycles per hour)	T_{2B}	Nm	175	175	175	255	255	250	255	175	250	255	250	250	220
		in.lb	1549	1549	1549	2257	2257	2213	2257	1549	2213	2257	2213	2213	1947
Emergency stop torque ^{a) b) e)} (permitted 1000 times during the service life of the gearbox)	T_{2Not}	Nm	480	480	480	480	480	480	480	315	480	480	480	480	480
		in.lb	4248	4248	4248	4248	4248	4248	4248	2788	4248	4248	4248	4248	4248
Permitted average input speed ^{d)} (at T_{2a} and 20 °C ambient temperature)	n_{1N}	rpm	2000	2000	2000	2000	2000	2000	2000	2000	2000	2000	2000	2000	2000
Max. input speed	n_{1Max}	rpm	4500	4500	4500	4500	4500	4500	4500	4500	4500	4500	4500	4500	4500
Mean no load running torque ^{b)} (at $n_1=3000$ rpm and 20 °C gearbox temperature)	T_{012}	Nm	3.8	3.8	3.8	3.8	3.8	3.8	3.8	3.8	3.8	3.8	3.8	3.8	3.8
		in.lb	34	34	34	34	34	34	34	34	34	34	34	34	34
Max. backlash	j_t	arcmin	≤ 17												
Torsional rigidity ^{b)}	C_{t21}	Nm/arcmin	16	16	16	16	16	16	16	16	16	16	16	16	16
		in.lb/arcmin	142	142	142	142	142	142	142	142	142	142	142	142	142
Max. axial force ^{c)}	F_{2AMax}	N	2500												
		lb _f	563												
Max. lateral force ^{c)}	F_{2QMax}	N	1750												
		lb _f	394												
Max. tilting moment	M_{2KMMax}	Nm	98												
		in.lb	867												
Efficiency at full load	η	%	94												
Service life	L_n	h	> 20000												
Weight (incl. standard adapter plate)	m	kg	10												
		lb _m	22												
Operating noise (at reference ratio and reference speed – ratio-specific values available in cymex®)	L_{PA}	dB(A)	≤ 74												
Max. permitted housing temperature		°C	+90												
		°F	+194												
Ambient temperature		°C	0 to +40												
		°F	+32 to +104												
Lubrication			Lubricated for life												
Direction of rotation			In- and output same direction												
Protection class			IP 64												
Elastomer coupling (recommended product type – validate sizing with cymex®)			ELC-0150BA025.000-X												
Bore diameter of coupling on the application side		mm	X = 019.000 - 036.000												
Mass moment of inertia (relates to the drive) Clamping hub diameter [mm]	H 28	J_1	kgcm ²	6.3	6.3	6.3	6.3	6.3	6.3	6.3	6.3	6.3	6.3	6.3	6.3
			10 ⁻³ in.lb.s ²	5.6	5.6	5.6	5.6	5.6	5.6	5.6	5.6	5.6	5.6	5.6	5.6

Please use our sizing software cymex® for a detailed sizing – www.wittenstein-cymex.com
Please consider the maximum permissible tilting moment caused by the motor M_{1KMot} – see sizing

- ^{a)} Valid for torque transmission only
- ^{b)} Valid for standard clamping hub diameter
- ^{c)} Refers to center of the output shaft or flange
- ^{d)} Please reduce input speed at higher ambient temperatures
- ^{e)} Valid for: Smooth shaft

alpha Basic Line

WORM GEARBOXES CVH / CVS

If the focus is on smooth running, smooth synchronization properties, and continuous operation, the V-Drive Basic is the right choice for you.

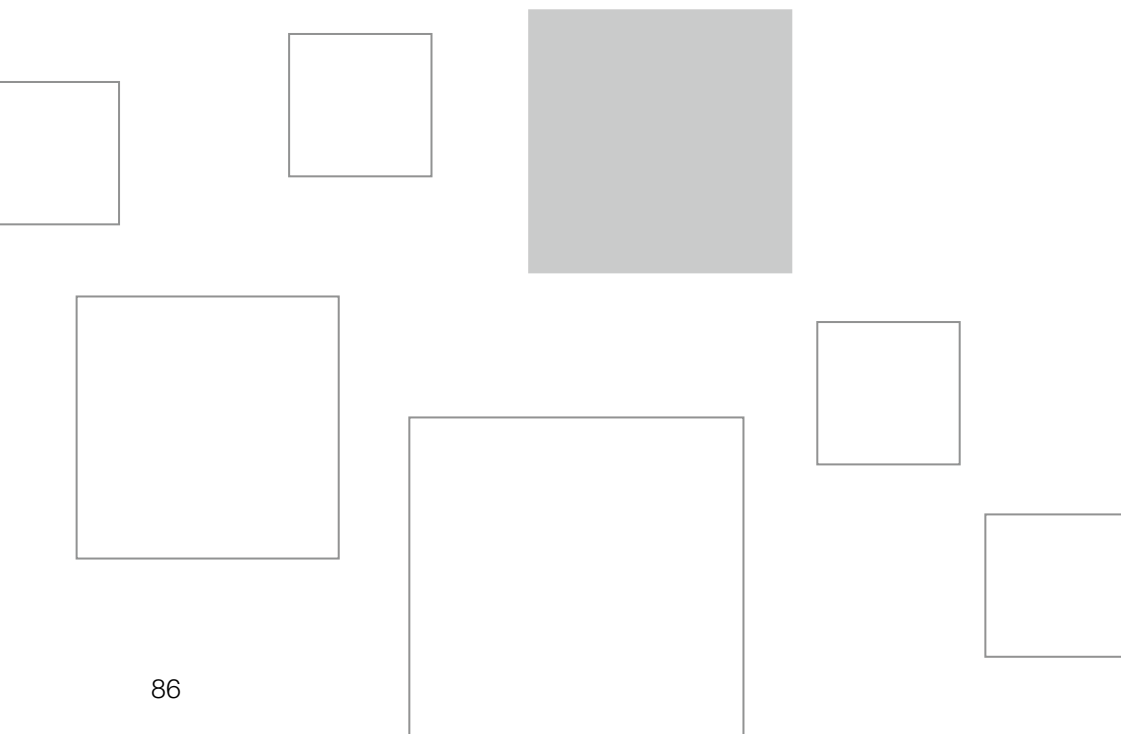

CVH

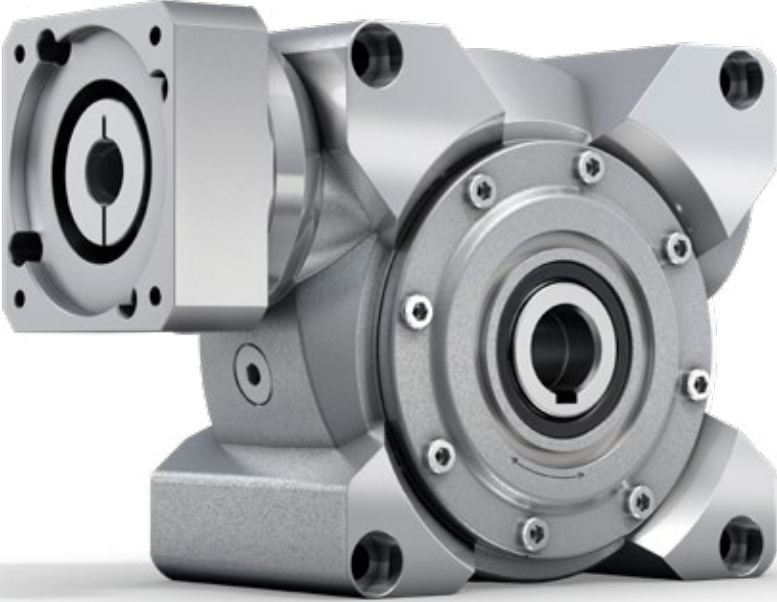

CVS

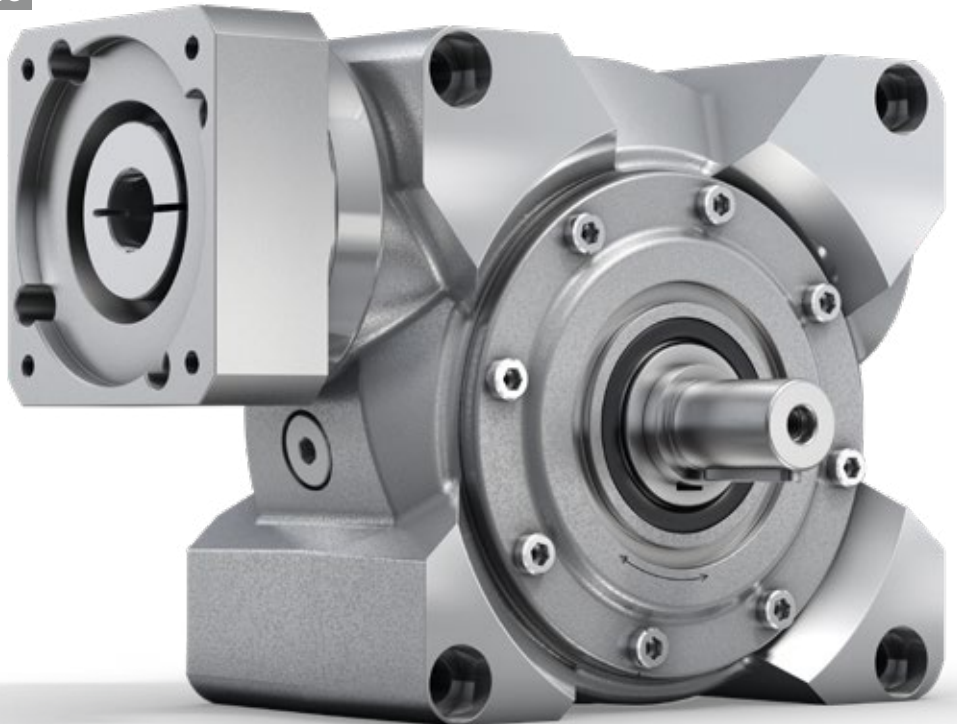

alpha Basic Line in action

COMPACT AND HIGH-PERFORMANCE WORM GEARBOX

in electronics production

When developing our customer's new rotary converter series, we had to meet three main objectives: offer the ability to dynamically adapt the conversion rate, minimize the cycle times, and improve the positioning accuracy.

With the V-Drive Basic by WITTENSTEIN alpha, the decision was made in favor of a high-performance servo worm gearbox which can be perfectly integrated into the system thanks to its compact design form.

This is made possible by a newly developed involute gearing of the worm gear set, which delivers a significant improvement in positioning and repetition accuracy with increased efficiency and very good running characteristics compared to the other converters. This provides a reduction in cycle times and therefore an increase in throughput performance in the application for feeding workpiece carriers or masks into various assembly, production, and inspection processes.

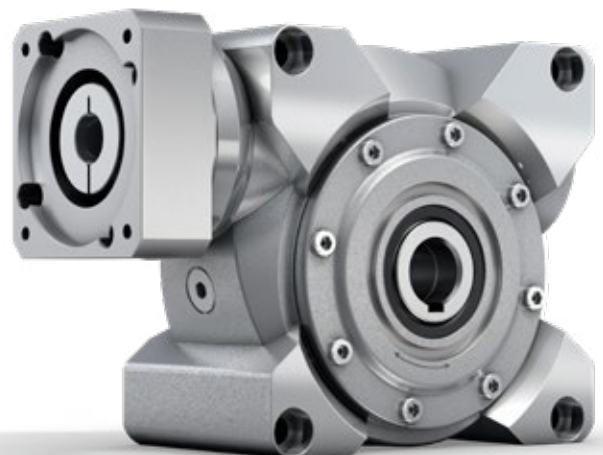



CVH / CVS – We drive the Performance

CVH

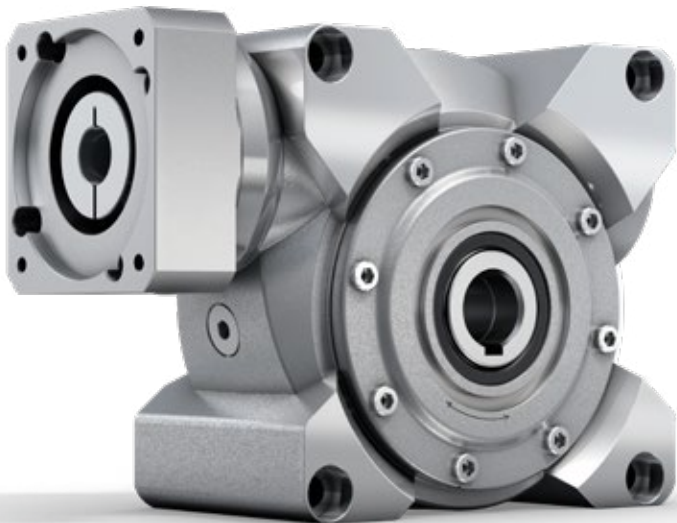

The V-Drive Basic is characterized by a specially developed toothing that minimizes operating noise during S1 operation and offers enormous power. And all with a top price/performance ratio.

PRODUCT HIGHLIGHTS

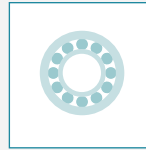

Optimized output bearings

The V-Drive Basic features an optimized output bearing tailored to the most diverse areas of application. For increased requirements for the absorption of external forces, the reinforced bearing option is used.



Specially developed toothing

The operating noise during S1 operation has been minimized by means of a specially developed toothing featuring high torques, good synchronization, and very low operating noise.



Top price/performance ratio

A top price/performance ratio is achieved with short delivery times and "made in Germany" quality.

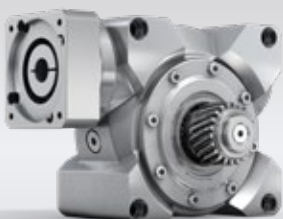

CVS – worm gearbox with pinion

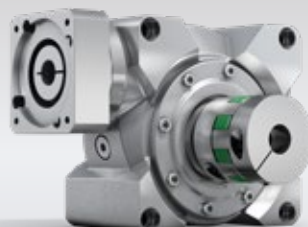

CVS – worm gearbox with elastomer coupling



cymex[®] select
BEST SOLUTION WITHIN SECONDS

Efficient gearbox sizing within seconds –
online without login
[cymex-select.wittenstein-group.com](https://www.cymex-select.wittenstein-group.com)

CVS

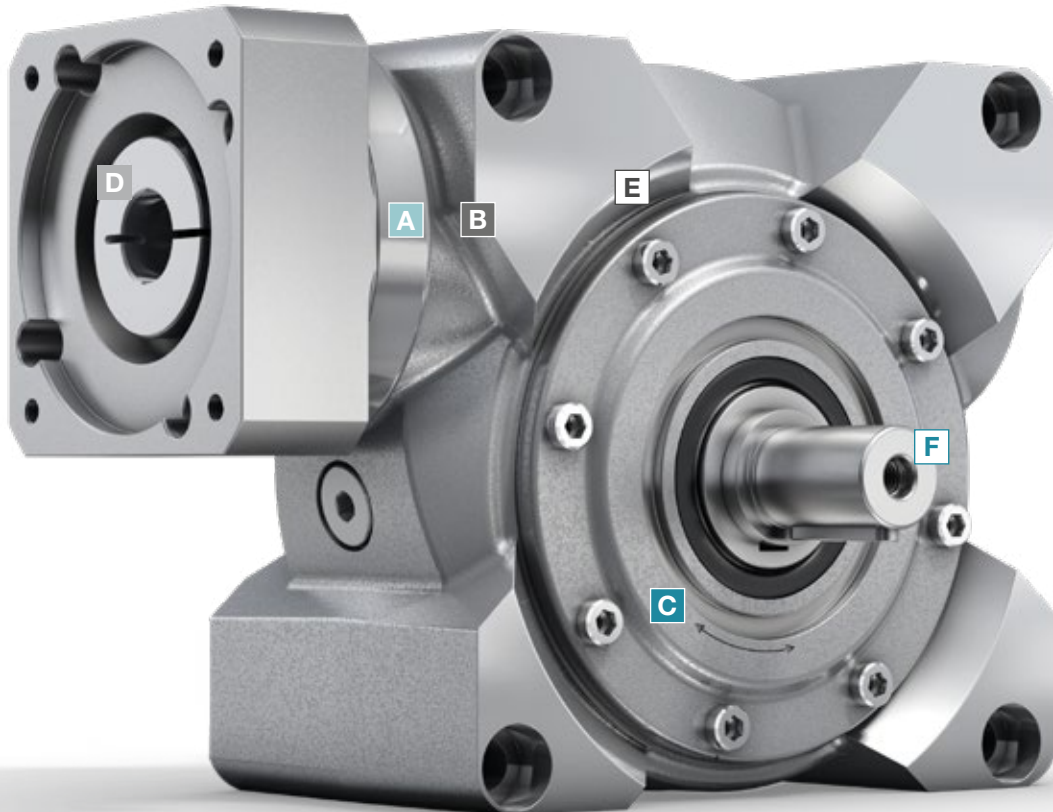

- A Radial shaft seal**
- Very long service life
 - Optimized for continuous operation

- B Input bearing**
- Bearing package to absorb axial and radial forces
 - Very well suited to high input speeds

- C Output bearing**
- Tailored to the most diverse areas of application

- D Metal bellows coupling**
- Completely backlash free
 - Lifetime durable and maintenance free
 - Easy assembly
 - Protects the motor through thermal linear expansion compensation

- E Toothing**
- Specially developed toothing, for high torques, good synchronization, and low operating noise

- F Multiple output configurations for greater flexibility**
- Hollow shaft interface
 - Keyed hollow shaft
 - Output on both sides
 - Smooth shaft
 - Shaft with key

CVH 040 MF 1-stage

			1-stage						
Ratio	i		7	10	16	28	40		
Max. torque ^{a) b)} (at $n_1 = 500$ rpm)	T_{2a}	Nm	68	76	78	82	76		
		in.lb	602	673	690	726	673		
Emergency stop torque ^{a) b)} (permitted 1000 times during the service life of the gearbox)	T_{2Not}	Nm	126	125	129	134	122		
		in.lb	1115	1106	1142	1186	1080		
Permitted average input speed ^{d)} (at 20 °C ambient temperature)	n_{1N}	rpm	4000						
Max. input speed	n_{1Max}	rpm	6000						
Mean no load running torque ^{b)} (at $n_1 = 3000$ rpm and 20 °C gearbox temperature)	T_{012}	Nm	0.7	0.6	0.5	0.4	0.4		
		in.lb	6.2	5.3	4.4	3.5	3.5		
Max. backlash	j_t	arcmin	≤ 15						
Torsional rigidity ^{b)}	C_{t21}	Nm/arcmin	3.5	3.5	3.5	3.5	3.5		
		in.lb/arcmin	31	31	31	31	31		
Max. axial force ^{c)} (Standard / HIGH FORCES)	F_{2AMax}	N	1200 / 3000						
		lb _f	270 / 675						
Max. lateral force ^{b)} (Standard / HIGH FORCES)	F_{2OMax}	N	1000 / 2400						
		lb _f	225 / 540						
Max. tilting moment (Standard / HIGH FORCES)	M_{2KMax}	Nm	97 / 205						
		in.lb	858 / 1814						
Efficiency at full load (at $n_1 = 500$ rpm)	η	%	89	87	81	72	66		
Service life	L_h	h	> 15000						
Weight (incl. standard adapter plate)	m	kg	4.5						
		lb _m	10						
Operating noise (at reference ratio and reference speed – ratio-specific values available in cymex [®])	L_{PA}	dB(A)	≤ 54						
Max. permitted housing temperature		°C	+90						
		°F	+194						
Ambient temperature		°C	-15 to +40						
		°F	+5 to +104						
Lubrication			Lubricated for life						
Direction of rotation			See drawing						
Protection class			IP 65						
Shrink disc (Standard Version)			SD 024x050 S2						
Max. torque (without axial force)	T_{max}	Nm	250						
		in.lb	2213						
Mass moment of inertia (relates to the drive) Clamping hub diameter [mm]	C	14	J_1	kgcm ²	0.42	0.39	0.37	0.36	0.35
				10 ⁻³ in.lb.s ²	0.37	0.35	0.33	0.32	0.31
	E	19	J_1	kgcm ²	0.74	0.70	0.68	0.68	0.67
				10 ⁻³ in.lb.s ²	0.65	0.62	0.6	0.6	0.59

Please use our sizing software cymex[®] for a detailed sizing – www.wittenstein-cymex.com

^{a)} At max. 10 % F_{2OMax}

^{b)} Valid for standard clamping hub diameter

^{c)} Refers to center of the output shaft or flange

^{d)} Please reduce input speed at higher ambient temperatures

Motor shaft diameter [mm]

1-stage

up to 14/19⁴⁾ (C⁶⁾/E)
clamping hub diameter

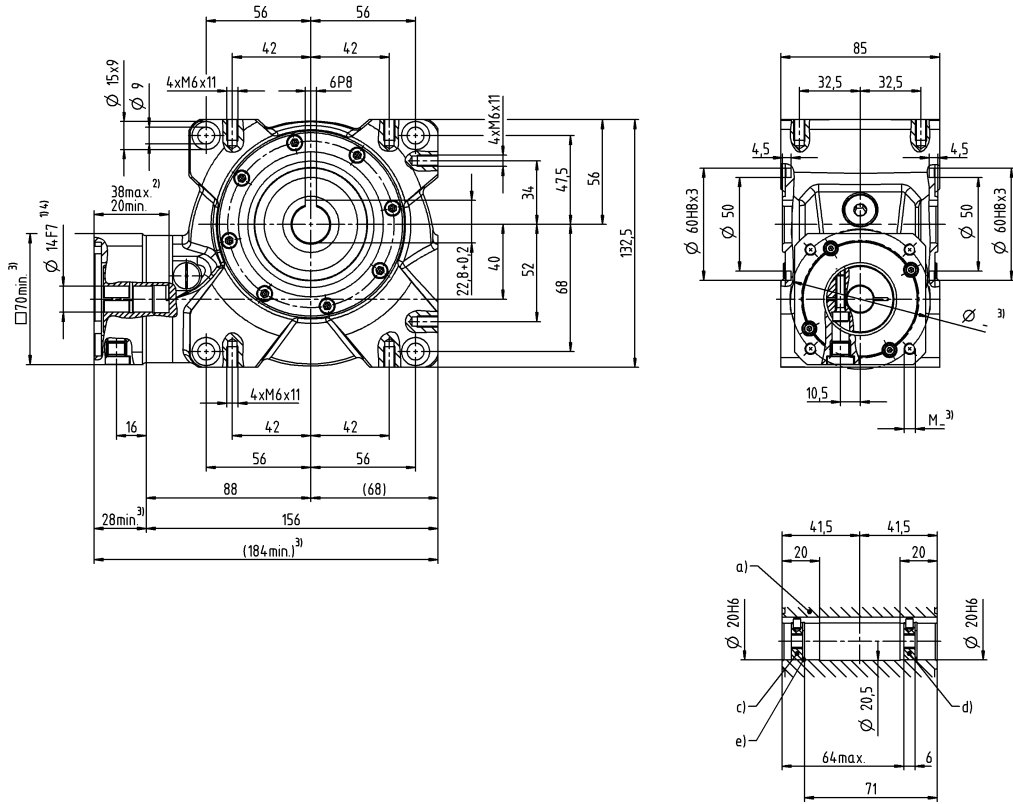

Worm Gearboxes
Basic Line

Other output variants

Hollow shaft interfaces on both sides

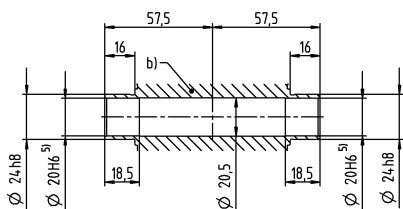

- a) Hollow shaft, keyed on both sides
- b) Hollow shaft interfaces on both sides
- c) End disc for screw M6 (on request)
- d) End disc as forcing washer for screw M8 (on request)
- e) Locking ring – DIN 472 (on request)

See technical data sheet for available clamping hub diameters (mass moment of inertia). Dimensions available on request.

Non-tolerated dimensions are nominal dimensions

- ¹⁾ Check motor shaft fit
- ²⁾ Min./Max. permissible motor shaft length
Longer motor shafts are adaptable, please contact us
- ³⁾ The dimensions depend on the motor
- ⁴⁾ Smaller motor shaft diameter is compensated by a bushing with a minimum wall thickness of 1 mm
- ⁵⁾ Tolerance h6 for mounted shaft
- ⁶⁾ Standard clamping hub diameter

CVH 050 MF 1-stage

			1-stage						
Ratio	i		7	10	16	28	40		
Max. torque ^{a) b)} (at $n_1 = 500$ rpm)	T_{2a}	Nm	125	127	131	140	116		
		in.lb	1106	1124	1159	1239	1027		
Emergency stop torque ^{a) b)} (permitted 1000 times during the service life of the gearbox)	T_{2Not}	Nm	242	242	250	262	236		
		in.lb	2142	2142	2213	2319	2089		
Permitted average input speed ^{d)} (at 20 °C ambient temperature)	n_{1N}	rpm	4000						
Max. input speed	n_{1Max}	rpm	6000						
Mean no load running torque ^{b)} (at $n_1 = 3000$ rpm and 20 °C gearbox temperature)	T_{012}	Nm	2.2	1.6	1.5	1.2	1.1		
		in.lb	19.5	14.2	13.3	10.6	9.7		
Max. backlash	j_t	arcmin	≤ 15						
Torsional rigidity ^{b)}	C_{t21}	Nm/arcmin	5.5	5.5	5.5	5.5	5.5		
		in.lb/arcmin	49	49	49	49	49		
Max. axial force ^{c)} (Standard / HIGH FORCES)	F_{2AMax}	N	1500 / 5000						
		lb _f	337.5 / 1125						
Max. lateral force ^{b)} (Standard / HIGH FORCES)	F_{2OMax}	N	1200 / 3800						
		lb _f	270 / 855						
Max. tilting moment (Standard / HIGH FORCES)	M_{2KMax}	Nm	130 / 409						
		in.lb	1150 / 3620						
Efficiency at full load (at $n_1 = 500$ rpm)	η	%	89	85	80	70	63		
Service life	L_n	h	> 15000						
Weight (incl. standard adapter plate)	m	kg	8						
		lb _m	18						
Operating noise (at reference ratio and reference speed – ratio-specific values available in cymex [®])	L_{PA}	dB(A)	≤ 62						
Max. permitted housing temperature		°C	+90						
		°F	+194						
Ambient temperature		°C	-15 to +40						
		°F	+5 to +104						
Lubrication			Lubricated for life						
Direction of rotation			See drawing						
Protection class			IP 65						
Shrink disc (Standard Version)			SD 030x060 S2V						
Max. torque (without axial force)	T_{max}	Nm	550						
		in.lb	4868						
Mass moment of inertia (relates to the drive) Clamping hub diameter [mm]	E	19	J_1	kgcm ²	1.2	1.1	1.0	0.97	1.0
				10 ⁻³ in.lb.s ²	1.1	0.97	0.89	0.86	0.89
	G	24	J_1	kgcm ²	1.3	1.2	1.1	1.1	1.2
				10 ⁻³ in.lb.s ²	1.2	1.1	0.97	0.97	1.1

Please use our sizing software cymex[®] for a detailed sizing – www.wittenstein-cymex.com

^{a)} At max. 10 % F_{2OMax}

^{b)} Valid for standard clamping hub diameter

^{c)} Refers to center of the output shaft or flange

^{d)} Please reduce input speed at higher ambient temperatures

Motor shaft diameter [mm]

1-stage

up to 19/24⁴⁾ (E⁶⁾/G)
clamping hub diameter

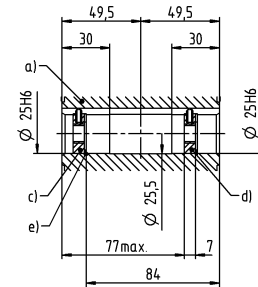
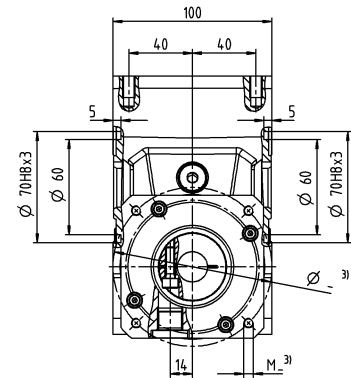
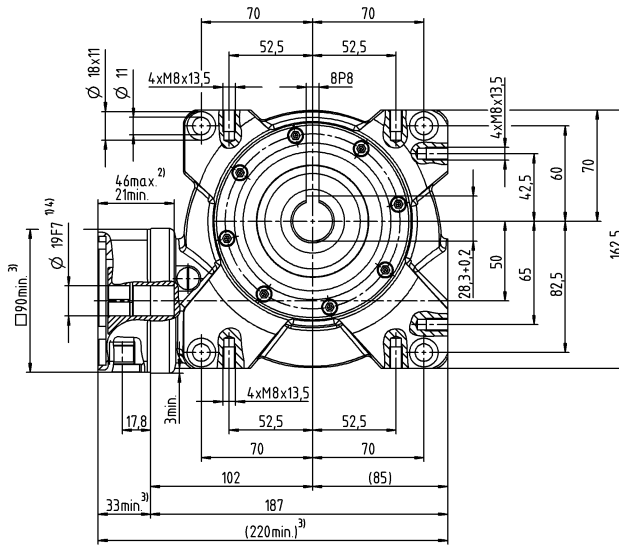

Other output variants

Hollow shaft interfaces on both sides

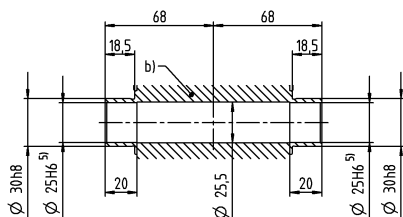

- a) Hollow shaft, keyed on both sides
- b) Hollow shaft interfaces on both sides
- c) End disc for screw M10 (on request)
- d) End disc as forcing washer for screw M12 (on request)
- e) Locking ring – DIN 472 (on request)

See technical data sheet for available clamping hub diameters (mass moment of inertia). Dimensions available on request.

Non-tolerated dimensions are nominal dimensions

- ¹⁾ Check motor shaft fit
- ²⁾ Min./Max. permissible motor shaft length
Longer motor shafts are adaptable, please contact us
- ³⁾ The dimensions depend on the motor
- ⁴⁾ Smaller motor shaft diameter is compensated by a bushing with a minimum wall thickness of 1 mm
- ⁵⁾ Tolerance h6 for mounted shaft
- ⁶⁾ Standard clamping hub diameter

CVH 063 MF 1-stage

			1-stage					
Ratio	<i>i</i>		7	10	16	28	40	
Max. torque ^{a) b)} (at $n_1 = 500$ rpm)	T_{2a}	Nm	265	270	280	301	282	
		in.lb	2345	2390	2478	2664	2496	
Emergency stop torque ^{a) b)} (permitted 1000 times during the service life of the gearbox)	T_{2Not}	Nm	484	491	494	518	447	
		in.lb	4283	4345	4372	4584	3956	
Permitted average input speed ^{d)} (at 20 °C ambient temperature)	n_{1N}	rpm	4000					
Max. input speed	n_{1Max}	rpm	4500					
Mean no load running torque ^{b)} (at $n_1 = 3000$ rpm and 20 °C gearbox temperature)	T_{012}	Nm	3.1	3	2.4	2.3	2.2	
		in.lb	27.4	26.6	21.2	20.4	19.5	
Max. backlash	j_t	arcmin	≤ 15					
Torsional rigidity ^{b)}	C_{t21}	Nm/arcmin	23	23	23	23	23	
		in.lb/arcmin	204	204	204	204	204	
Max. axial force ^{c)} (Standard / HIGH FORCES)	F_{2AMax}	N	2000 / 8250					
		lb _f	450 / 1856					
Max. lateral force ^{b)} (Standard / HIGH FORCES)	F_{2OMax}	N	2000 / 6000					
		lb _f	450 / 1350					
Max. tilting moment (Standard / HIGH FORCES)	M_{2KMax}	Nm	281 / 843					
		in.lb	2487 / 7461					
Efficiency at full load (at $n_1 = 500$ rpm)	η	%	90	87	82	73	67	
Service life	L_n	h	> 15000					
Weight (incl. standard adapter plate)	m	kg	13					
		lb _m	29					
Operating noise (at reference ratio and reference speed – ratio-specific values available in cymex [®])	L_{PA}	dB(A)	≤ 64					
Max. permitted housing temperature		°C	+90					
		°F	+194					
Ambient temperature		°C	-15 to +40					
		°F	+5 to +104					
Lubrication			Lubricated for life					
Direction of rotation			See drawing					
Protection class			IP 65					
Shrink disc (Standard Version)			SD 036x072 S2V					
Max. torque (without axial force)	T_{max}	Nm	640					
		in.lb	5664					
Mass moment of inertia (relates to the drive) Clamping hub diameter [mm]	H 28	J_1	kgcm ²	4.0	3.8	3.7	3.6	3.6
			10 ⁻³ in.lb.s ²	3.5	3.4	3.3	3.2	3.2

Please use our sizing software cymex[®] for a detailed sizing – www.wittenstein-cymex.com

^{a)} At max. 10 % F_{2OMax}

^{b)} Valid for standard clamping hub diameter

^{c)} Refers to center of the output shaft or flange

^{d)} Please reduce input speed at higher ambient temperatures

Motor shaft diameter [mm]

1-stage

up to 28⁴⁾ (H)⁶⁾
clamping hub diameter

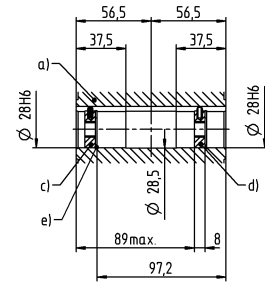
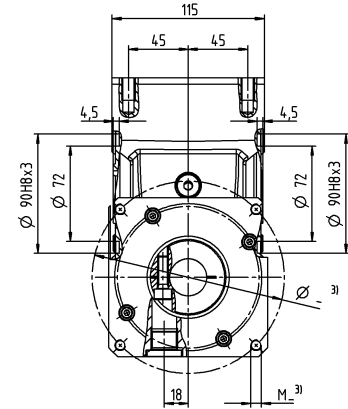
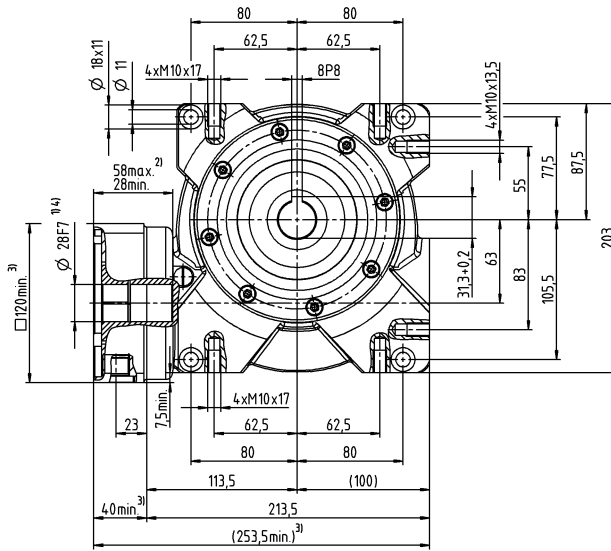

Other output variants

Hollow shaft interfaces on both sides

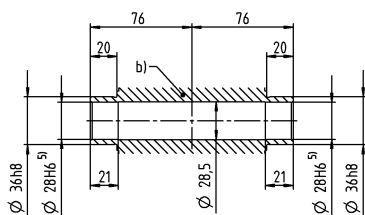

- a) Hollow shaft, keyed on both sides
- b) Hollow shaft interfaces on both sides
- c) End disc for screw M10 (on request)
- d) End disc as forcing washer for screw M12 (on request)
- e) Locking ring – DIN 472 (on request)

See technical data sheet for available clamping hub diameters (mass moment of inertia). Dimensions available on request.

Non-tolerated dimensions are nominal dimensions

- ¹⁾ Check motor shaft fit
- ²⁾ Min./Max. permissible motor shaft length
Longer motor shafts are adaptable, please contact us
- ³⁾ The dimensions depend on the motor
- ⁴⁾ Smaller motor shaft diameter is compensated by a bushing with a minimum wall thickness of 1 mm
- ⁵⁾ Tolerance h6 for mounted shaft
- ⁶⁾ Standard clamping hub diameter

CVS 040 MF 1-stage

			1-stage						
Ratio	i		7	10	16	28	40		
Max. torque ^{a) b) e)} (at $n_1 = 500$ rpm)	T_{2a}	Nm	68	76	78	82	76		
		in.lb	602	673	690	726	673		
Emergency stop torque ^{a) b) e)} (permitted 1000 times during the service life of the gearbox)	T_{2Not}	Nm	126	125	129	134	122		
		in.lb	1115	1106	1142	1186	1080		
Permitted average input speed ^{d)} (at 20 °C ambient temperature)	n_{1N}	rpm	4000						
Max. input speed	n_{1Max}	rpm	6000						
Mean no load running torque ^{b)} (at $n_1 = 3000$ rpm and 20 °C gearbox temperature)	T_{012}	Nm	0.7	0.6	0.5	0.4	0.4		
		in.lb	6.2	5.3	4.4	3.5	3.5		
Max. backlash	j_t	arcmin	≤ 15						
Torsional rigidity ^{b)}	C_{t21}	Nm/arcmin	3.5	3.5	3.5	3.5	3.5		
		in.lb/arcmin	31	31	31	31	31		
Max. axial force ^{c)} (Standard / HIGH FORCES)	F_{2AMax}	N	1200 / 3000						
		lb _f	270 / 675						
Max. lateral force ^{b)} (Standard / HIGH FORCES)	F_{2OMax}	N	1000 / 2400						
		lb _f	225 / 540						
Max. tilting moment (Standard / HIGH FORCES)	M_{2KMax}	Nm	97 / 205						
		in.lb	858 / 1814						
Efficiency at full load (at $n_1 = 500$ rpm)	η	%	89	87	81	72	66		
Service life	L_n	h	> 15000						
Weight (incl. standard adapter plate)	m	kg	4.5						
		lb _m	10						
Operating noise (at reference ratio and reference speed – ratio-specific values available in cymex [®])	L_{PA}	dB(A)	≤ 54						
Max. permitted housing temperature		°C	+90						
		°F	+194						
Ambient temperature		°C	-15 to +40						
		°F	+5 to +104						
Lubrication			Lubricated for life						
Direction of rotation			See drawing						
Protection class			IP 65						
Elastomer coupling (recommended product type – validate sizing with cymex [®])			ELC - 00060B - 016.000 - X						
Bore diameter of coupling on the application side		mm	X = 016.000 - 032.000						
Mass moment of inertia (relates to the drive) Clamping hub diameter [mm]	C	14	J_1	kgcm ²	0.42	0.39	0.37	0.36	0.35
				10 ⁻³ in.lb.s ²	0.37	0.35	0.33	0.32	0.31
	E	19	J_1	kgcm ²	0.74	0.70	0.68	0.68	0.67
				10 ⁻³ in.lb.s ²	0.65	0.62	0.60	0.6	0.59

Please use our sizing software cymex[®] for a detailed sizing – www.wittenstein-cymex.com

- ^{a)} At max. 10 % F_{2OMax}
- ^{b)} Valid for standard clamping hub diameter
- ^{c)} Refers to center of the output shaft or flange
- ^{d)} Please reduce input speed at higher ambient temperatures
- ^{e)} Valid for: Smooth shaft

Motor shaft diameter [mm]

1-stage

up to 14/19⁴⁾ (C⁶⁾/E)
clamping hub diameter

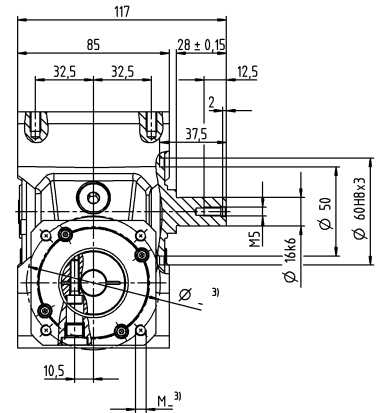
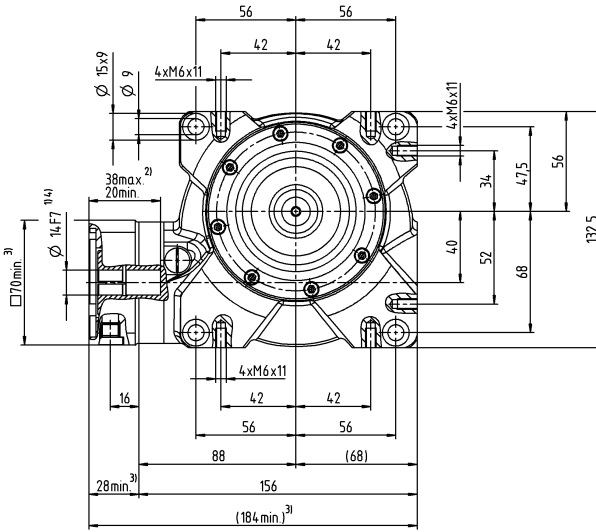

A⁵¹⁾

B⁵¹⁾

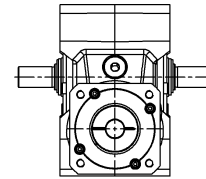
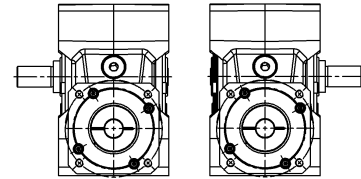

Worm Gearboxes
Basic Line

Optional dual-shaft output. Drawings available on request.
Involute gearing is not possible.

Other output variants

Shaft with key

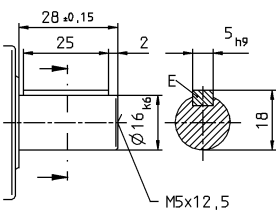

See technical data sheet for available clamping hub diameters (mass moment of inertia). Dimensions available on request.

- Non-tolerated dimensions are nominal dimensions
- ¹⁾ Check motor shaft fit
- ²⁾ Min./Max. permissible motor shaft length
Longer motor shafts are adaptable, please contact us
- ³⁾ The dimensions depend on the motor
- ⁴⁾ Smaller motor shaft diameter is compensated by a bushing with a minimum wall thickness of 1 mm
- ⁵⁾ Output side
- ⁶⁾ Standard clamping hub diameter

CVS 050 MF 1-stage

			1-stage						
Ratio	i		7	10	16	28	40		
Max. torque ^{a) b) e)} (at $n_1 = 500$ rpm)	T_{2a}	Nm	125	127	131	140	116		
		in.lb	1106	1124	1159	1239	1027		
Emergency stop torque ^{a) b) e)} (permitted 1000 times during the service life of the gearbox)	T_{2Not}	Nm	242	242	250	262	236		
		in.lb	2142	2142	2213	2319	2089		
Permitted average input speed ^{d)} (at 20 °C ambient temperature)	n_{1N}	rpm	4000						
Max. input speed	n_{1Max}	rpm	6000						
Mean no load running torque ^{b)} (at $n_1 = 3000$ rpm and 20 °C gearbox temperature)	T_{012}	Nm	2.2	1.6	1.5	1.2	1.1		
		in.lb	19.5	14.2	13.3	10.6	9.7		
Max. backlash	j_t	arcmin	≤ 15						
Torsional rigidity ^{b)}	C_{t21}	Nm/arcmin	5.5	5.5	5.5	5.5	5.5		
		in.lb/arcmin	49	49	49	49	49		
Max. axial force ^{c)} (Standard / HIGH FORCES)	F_{2AMax}	N	1500 / 5000						
		lb _f	337.5 / 1125						
Max. lateral force ^{b)} (Standard / HIGH FORCES)	F_{2OMax}	N	1200 / 3800						
		lb _f	270 / 855						
Max. tilting moment (Standard / HIGH FORCES)	M_{2KMax}	Nm	130 / 409						
		in.lb	1150 / 3620						
Efficiency at full load (at $n_1 = 500$ rpm)	η	%	89	85	80	70	63		
Service life	L_n	h	> 15000						
Weight (incl. standard adapter plate)	m	kg	8						
		lb _m	18						
Operating noise (at reference ratio and reference speed – ratio-specific values available in cymex [®])	L_{PA}	dB(A)	≤ 62						
Max. permitted housing temperature		°C	+90						
		°F	+194						
Ambient temperature		°C	-15 to +40						
		°F	+5 to +104						
Lubrication			Lubricated for life						
Direction of rotation			See drawing						
Protection class			IP 65						
Elastomer coupling (recommended product type – validate sizing with cymex [®])			ELC - 00150B - 022.000 - X						
Bore diameter of coupling on the application side		mm	X = 022.000 - 036.000						
Mass moment of inertia (relates to the drive) Clamping hub diameter [mm]	E	19	J_1	kgcm ²	1.2	1.1	1.0	0.97	1.0
				10 ⁻³ in.lb.s ²	1.1	0.97	0.89	0.86	0.89
	G	24	J_1	kgcm ²	1.3	1.2	1.1	1.1	1.2
				10 ⁻³ in.lb.s ²	1.2	1.1	0.97	0.97	1.1

Please use our sizing software cymex[®] for a detailed sizing – www.wittenstein-cymex.com

^{a)} At max. 10 % F_{2OMax}

^{b)} Valid for standard clamping hub diameter

^{c)} Refers to center of the output shaft or flange

^{d)} Please reduce input speed at higher ambient temperatures

^{e)} Valid for: Smooth shaft

Motor shaft diameter [mm]

1-stage

up to 19/24⁴⁾ (E⁶⁾/G)
clamping hub diameter

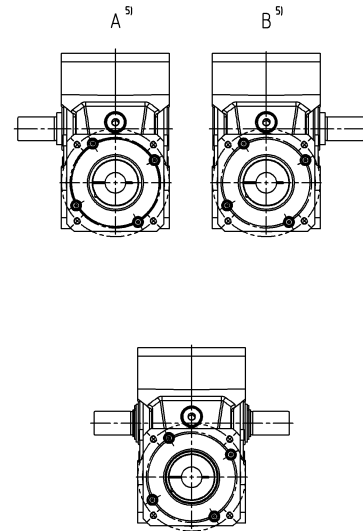
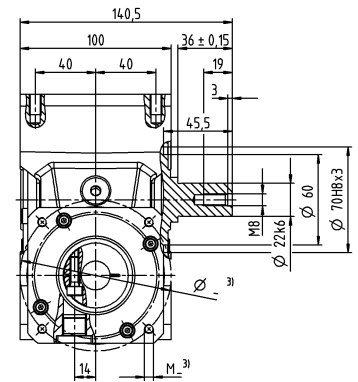
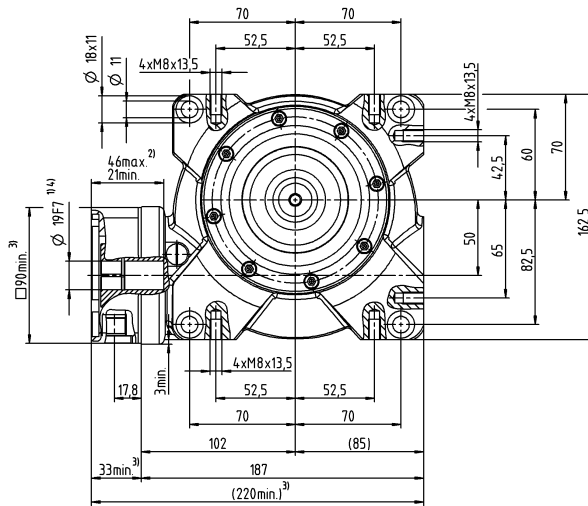

Worm Gearboxes
Basic Line

Optional dual-shaft output. Drawings available on request.
Involute gearing is not possible.

Other output variants

Shaft with key

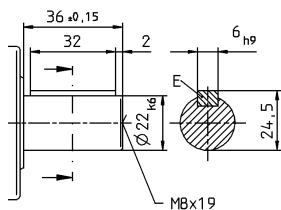

See technical data sheet for available clamping hub diameters (mass moment of inertia). Dimensions available on request.

- Non-tolerated dimensions are nominal dimensions
- ¹⁾ Check motor shaft fit
- ²⁾ Min./Max. permissible motor shaft length
Longer motor shafts are adaptable, please contact us
- ³⁾ The dimensions depend on the motor
- ⁴⁾ Smaller motor shaft diameter is compensated by a bushing with a minimum wall thickness of 1 mm
- ⁵⁾ Output side
- ⁶⁾ Standard clamping hub diameter

CVS 063 MF 1-stage

			1-stage					
Ratio	i		7	10	16	28	40	
Max. torque ^{a) b) e)} (at $n_1 = 500$ rpm)	T_{2a}	Nm	265	270	280	301	282	
		in.lb	2345	2390	2478	2664	2496	
Emergency stop torque ^{a) b) e)} (permitted 1000 times during the service life of the gearbox)	T_{2Not}	Nm	484	491	494	518	447	
		in.lb	4283	4345	4372	4584	3956	
Permitted average input speed ^{d)} (at 20 °C ambient temperature)	n_{1N}	rpm	4000					
Max. input speed	n_{1Max}	rpm	4500					
Mean no load running torque ^{b)} (at $n_1 = 3000$ rpm and 20 °C gearbox temperature)	T_{012}	Nm	3.1	3	2.4	2.3	2.2	
		in.lb	27.4	26.6	21.2	20.4	19.5	
Max. backlash	j_t	arcmin	≤ 15					
Torsional rigidity ^{b)}	C_{t21}	Nm/arcmin	23	23	23	23	23	
		in.lb/arcmin	204	204	204	204	204	
Max. axial force ^{c)} (Standard / HIGH FORCES)	F_{2AMax}	N	2000 / 8250					
		lb _f	450 / 1856					
Max. lateral force ^{b)} (Standard / HIGH FORCES)	F_{2OMax}	N	2000 / 6000					
		lb _f	450 / 1350					
Max. tilting moment (Standard / HIGH FORCES)	M_{2KMax}	Nm	281 / 843					
		in.lb	2487 / 7461					
Efficiency at full load (at $n_1 = 500$ rpm)	η	%	90	87	82	73	67	
Service life	L_n	h	> 15000					
Weight (incl. standard adapter plate)	m	kg	13					
		lb _m	29					
Operating noise (at reference ratio and reference speed – ratio-specific values available in cymex [®])	L_{PA}	dB(A)	≤ 64					
Max. permitted housing temperature		°C	+90					
		°F	+194					
Ambient temperature		°C	-15 to +40					
		°F	+5 to +104					
Lubrication			Lubricated for life					
Direction of rotation			See drawing					
Protection class			IP 65					
Elastomer coupling (recommended product type – validate sizing with cymex [®])			ELC - 00150B - 032.000 - X					
Bore diameter of coupling on the application side		mm	X = 032.000 - 036.000					
Mass moment of inertia (relates to the drive) Clamping hub diameter [mm]	H 28	J_1	kgcm ²	4.0	3.8	3.7	3.6	3.6
			10 ⁻³ in.lb.s ²	3.5	3.4	3.3	3.2	3.2

Please use our sizing software cymex[®] for a detailed sizing – www.wittenstein-cymex.com

- ^{a)} At max. 10 % F_{2OMax}
- ^{b)} Valid for standard clamping hub diameter
- ^{c)} Refers to center of the output shaft or flange
- ^{d)} Please reduce input speed at higher ambient temperatures
- ^{e)} Valid for: Smooth shaft

Motor shaft diameter [mm]

1-stage

up to 28⁴⁾ (H)⁶⁾
clamping hub diameter

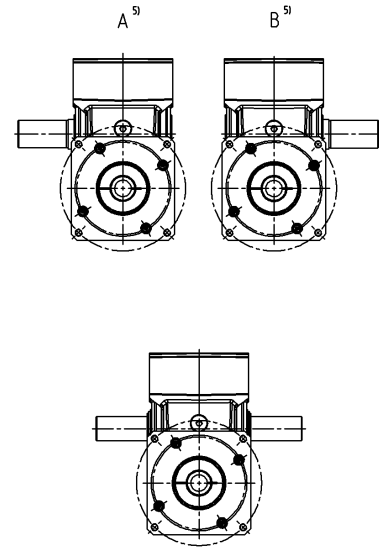
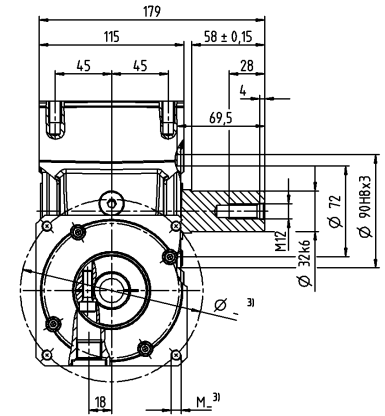
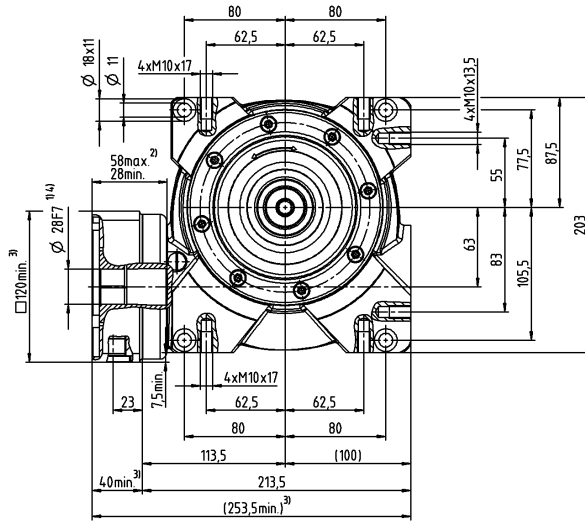

Worm Gearboxes
Basic Line

Optional dual-shaft output. Drawings available on request.
Involute gearing is not possible.

Other output variants

Shaft with key

Shaft with parallel key on both sides

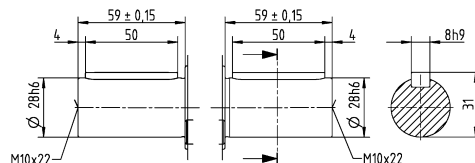
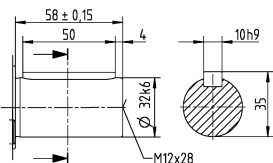

See technical data sheet for available clamping hub diameters (mass moment of inertia). Dimensions available on request.

- Non-tolerated dimensions are nominal dimensions
- ¹⁾ Check motor shaft fit
- ²⁾ Min./Max. permissible motor shaft length
Longer motor shafts are adaptable, please contact us
- ³⁾ The dimensions depend on the motor
- ⁴⁾ Smaller motor shaft diameter is compensated by a bushing with a minimum wall thickness of 1 mm
- ⁵⁾ Output side
- ⁶⁾ Standard clamping hub diameter

alpha Value Line

PLANETARY GEARBOXES NP / NPL / NPS / NPT / NPR / NTP

The strength of the planetary gearboxes of the alpha Value Line lies in the combination of economy and variety of output variants. Additionally, the gearboxes are suitable for very diverse applications – thanks to the range of ratios and the optimal positioning accuracy.

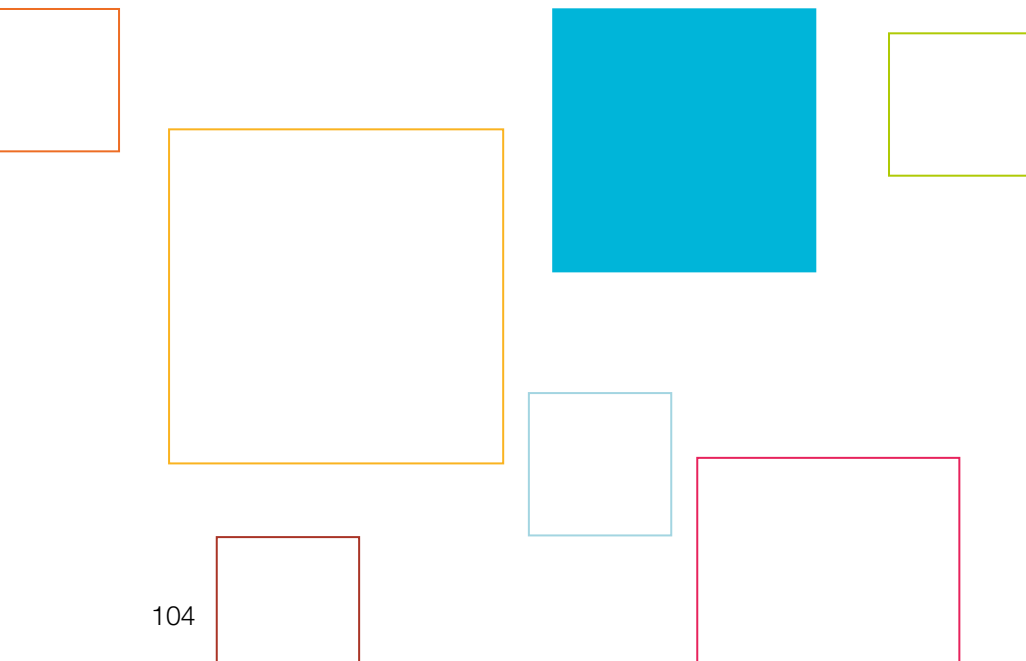

NPT

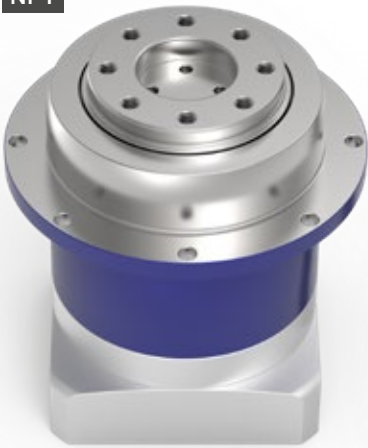

NP

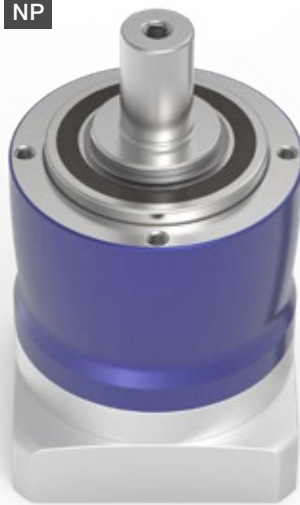

NPL

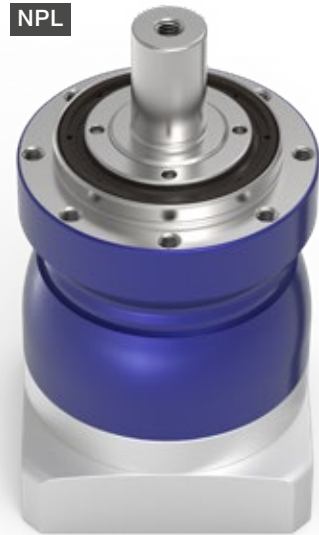

NPS

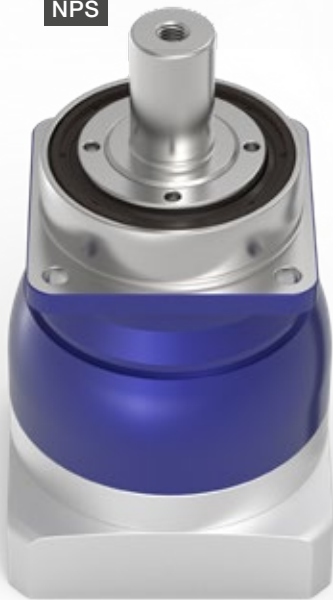

NPR



NTP



alpha Value Line in action

INDIVIDUAL TALENTS – for trend-setting research

The planetary gearboxes of the alpha Value Line are suitable for universal application and offer the best economical solution for almost every requirement – on each axis and for all industries.

But the NP servo gearbox is also used outside the typical industrial environment: For research purposes, the planetary gearboxes are used in installations for the simulation of tides or tsunamis as well as for coastline and port basin optimization. With the wave simulators, shipyards or research centers can simulate and investigate the behavior of ships at sea or in a port, in ordinary but also in extreme situations.

The low-backlash NP planetary gearboxes of the alpha Value Line drive axes optimally in installations of multi-servo axes in wave tanks worldwide – for example in Great Britain, the USA, China and Italy.

Each wave simulator has a certain number of paddles for generating very special wave types and frequencies. Depending on the size of the simulator and the type of wave to be simulated – deep and shallow water, sea, current and storm conditions or river mouths – a belt drive, ball screw or rack and pinion drive are used. The size of the individual paddles can vary from a few centimeters to several meters.

Technical support, quality and flexibility were the decisive factors for the decision to cooperate with WITTENSTEIN in the simulation system. The NP gearboxes of the alpha Value Line offer the customer the ideal mix of precision, dynamic performance and price.

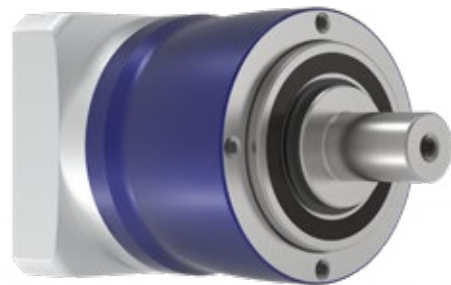



NP / NPL / NPS / NPT / NPR / NTP

– Individual Talents

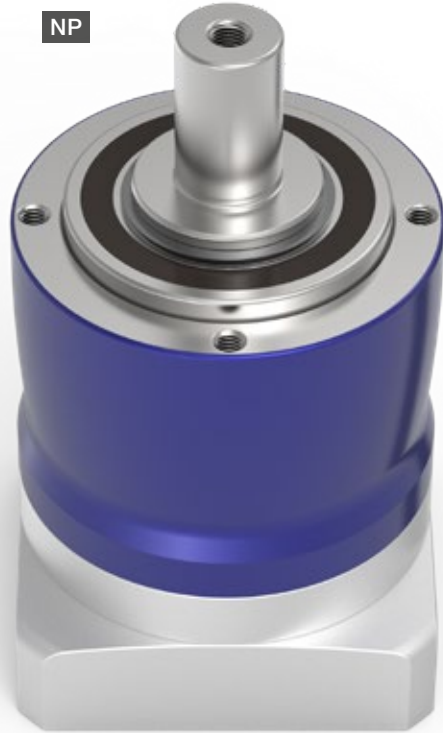

The planetary gearboxes of the alpha Value Line are suitable for universal application and offer the best, most economical solution for virtually all requirements – on each axis and for all industries. The various drives and output Interfaces are offered as a compatible extension to the existing portfolio of WITTENSTEIN alpha – for maximum flexibility in design, assembly, and use.

PRODUCT HIGHLIGHTS



Unique modularity in this segment

With five series including five different output interfaces, the NP series offers maximum flexibility. From a simple machine connection using a B5 or B14 output flange to a flange connection or adjustment via slotted holes – the suitable solution for your machine requirements.



High economy

The gearboxes of the alpha Value Line are very economical to purchase, unbeatably efficient in operation, and maintenance free over their entire service life.

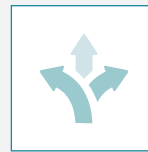

High flexibility

Modular configuration of the interfaces to the motor and to the application. The gearboxes are available with different clamping hub diameters, drive stages, design and mounting options.



Highest power density

The HIGH TORQUE version provides gearboxes with the highest power density.



Fast sizing

Efficient and innovative online sizing within seconds in cymex® select based on technical and economic suitability.



NPS – planetary gearbox with SP* output geometry

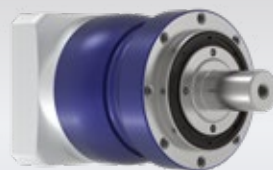

NPL – planetary gearbox with reinforced bearings and B14 output geometry

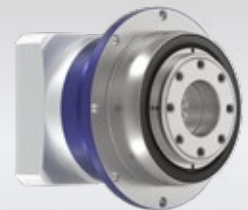

NTP – planetary gearbox with TP* output geometry



More information about the alpha Value Line: simply scan the QR code using your smartphone.

alpha.wittenstein.de/en-en/alpha-value-line



A Two-piece clamping hub system of the high-end segment

- Labeled with the tightening torques for secure, fast motor mounting
- Guarantees best synchronization properties

B Multiple output configurations for greater flexibility

- Smooth shaft
- Shaft with key
- Splined shaft (DIN 5480)
- Flange

C High ratio variation

- Large number of ratios ($i=3$ to $i=100$)
- Available in the common binary ratios

D Differentiated power density

- The HIGH TORQUE version permits an even higher torque density for sizes 015 – 035

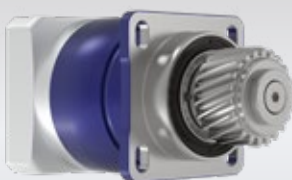

cymex® select
BEST SOLUTION WITHIN SECONDS

NP 005 MF 1-stage

			1-stage						
Ratio	i		4	5	7	8	10		
Max. torque ^{a) b) e)}	T_{2a}	Nm	18	22	22	21	21		
		in.lb	159	195	195	186	186		
Max. acceleration torque ^{e)} (max. 1000 cycles per hour)	T_{2B}	Nm	11	14	14	13	13		
		in.lb	97	124	124	115	115		
Emergency stop torque ^{a) b) e)} (permitted 1000 times during the service life of the gearbox)	T_{2Not}	Nm	26	26	26	26	26		
		in.lb	230	230	230	230	230		
Permitted average input speed ^{d)} (at T_{2a} and 20 °C ambient temperature)	n_{1N}	rpm	3800	4000	4300	4400	4600		
Max. input speed	n_{1Max}	rpm	10000	10000	10000	10000	10000		
Mean no load running torque ^{b)} (at $n_1=3000$ rpm and 20 °C gearbox temperature)	T_{012}	Nm	0.1	0.09	0.08	0.08	0.08		
		in.lb	0.89	0.8	0.71	0.71	0.71		
Max. backlash	j_1	arcmin	≤ 10						
Torsional rigidity ^{b)}	C_{121}	Nm/arcmin	1.2	1.2	1.2	0.85	0.85		
		in.lb/arcmin	11	11	11	7.5	7.5		
Max. axial force ^{c)}	F_{2AMax}	N	700						
		lb _f	158						
Max. lateral force ^{c)}	F_{2QMMax}	N	800						
		lb _f	180						
Max. tilting moment	M_{2KMMax}	Nm	23						
		in.lb	204						
Efficiency at full load	η	%	97						
Service life	L_n	h	> 20000						
Weight (incl. standard adapter plate)	m	kg	0.7						
		lb _m	1.5						
Operating noise (at reference ratio and reference speed – ratio-specific values available in cymex®)	L_{PA}	dB(A)	≤ 58						
		°C	+90						
Max. permitted housing temperature		°F	+194						
		°C	-15 to +40						
Ambient temperature		°F	+5 to +104						
			Lubricated for life						
Lubrication			Lubricated for life						
Direction of rotation			In- and output same direction						
Protection class			IP 64						
Elastomer coupling (recommended product type – validate sizing with cymex®)			ELC-0005BA012.000-X						
Bore diameter of coupling on the application side		mm	X = 004.000 - 012.700						
Mass moment of inertia (relates to the drive) Clamping hub diameter [mm]	Z	8	J_1	kgcm ²	0.03	0.03	0.03	0.02	0.02
				10 ⁻³ in.lb.s ²	0.03	0.03	0.03	0.02	0.02
	A	9	J_1	kgcm ²	0.03	0.03	0.03	0.03	0.02
				10 ⁻³ in.lb.s ²	0.03	0.03	0.03	0.03	0.02
	B	11	J_1	kgcm ²	0.05	0.05	0.04	0.04	0.04
				10 ⁻³ in.lb.s ²	0.04	0.04	0.04	0.04	0.04
	C	14	J_1	kgcm ²	0.14	0.13	0.13	0.13	0.13
				10 ⁻³ in.lb.s ²	0.12	0.12	0.12	0.12	0.12

Please use our sizing software cymex® for a detailed sizing – www.wittenstein-cymex.com

^{a)} Valid for torque transmission only

^{b)} Valid for standard clamping hub diameter

^{c)} Refers to center of the output shaft or flange

^{d)} Please reduce input speed at higher ambient temperatures

^{e)} Valid for: Smooth shaft

1-stage

Motor shaft diameter [mm]

up to 11⁴⁾ (B)⁵⁾
clamping hub diameter

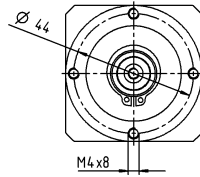

up to 14⁴⁾ (C)
clamping hub diameter

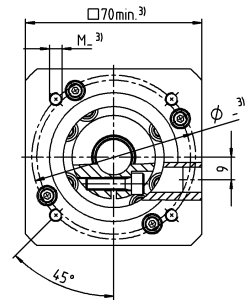
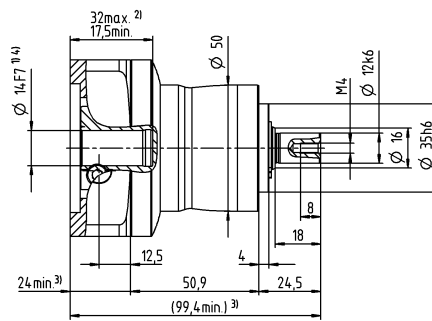
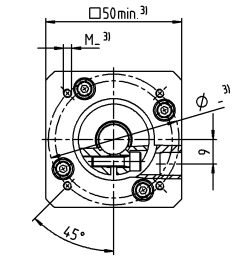
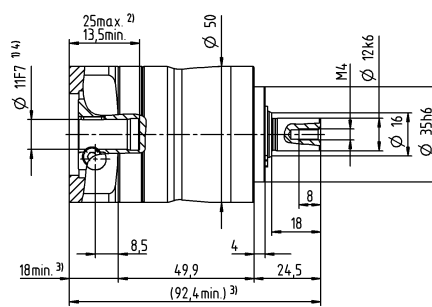
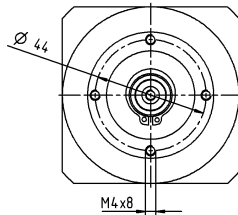

Other output variants

Shaft with key

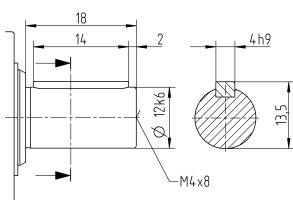

Non-tolerated dimensions are nominal dimensions

¹⁾ Check motor shaft fit

²⁾ Min. / Max. permissible motor shaft length

Longer motor shafts are possible, please contact alpha

³⁾ The dimensions depend on the motor

⁴⁾ Smaller motor shaft diameter is compensated

by a bushing with a minimum wall thickness of 1 mm

⁵⁾ Standard clamping hub diameter

NP 005 MF 2-stage

			2-stage										
Ratio	i		16	20	25	28	35	40	50	64	70	100	
Max. torque ^{a) b) e)}	T_{2a}	Nm	18	18	22	18	22	18	22	21	22	21	
		in.lb	159	159	195	159	195	159	195	186	195	186	
Max. acceleration torque ^{e)} (max. 1000 cycles per hour)	T_{2B}	Nm	11	11	14	11	14	11	14	13	14	13	
		in.lb	97	97	124	97	124	97	124	115	124	115	
Emergency stop torque ^{a) b) e)} (permitted 1000 times during the service life of the gearbox)	T_{2Not}	Nm	26	26	26	26	26	26	26	26	26	26	
		in.lb	230	230	230	230	230	230	230	230	230	230	
Permitted average input speed ^{d)} (at T_{2N} and 20 °C ambient temperature)	n_{1N}	rpm	4000	4000	4000	4300	4300	4600	4600	4400	4600	4600	
Max. input speed	n_{1Max}	rpm	10000	10000	10000	10000	10000	10000	10000	10000	10000	10000	
Mean no load running torque ^{b)} (at $n_1=3000$ rpm and 20 °C gearbox temperature)	T_{012}	Nm	0.11	0.1	0.1	0.09	0.09	0.08	0.08	0.08	0.08	0.08	
		in.lb	0.97	0.89	0.89	0.8	0.8	0.71	0.71	0.71	0.71	0.71	
Max. backlash	j_l	arcmin	≤ 13										
Torsional rigidity ^{b)}	C_{121}	Nm/arcmin	1.2	1.2	1.2	1.2	1.2	1.2	1.2	0.85	1.2	0.85	
		in.lb/arcmin	11	11	11	11	11	11	11	7.5	11	7.5	
Max. axial force ^{c)}	F_{2AMax}	N	700										
		lb _f	158										
Max. lateral force ^{c)}	F_{2QMMax}	N	800										
		lb _f	180										
Max. tilting moment	M_{2KMMax}	Nm	23										
		in.lb	204										
Efficiency at full load	η	%	95										
Service life	L_n	h	> 20000										
Weight (incl. standard adapter plate)	m	kg	0.9										
		lb _m	2										
Operating noise (at reference ratio and reference speed – ratio-specific values available in cymex®)	L_{PA}	dB(A)	≤ 58										
Max. permitted housing temperature		°C	+90										
		°F	+194										
Ambient temperature		°C	-15 to +40										
		°F	+5 to +104										
Lubrication			Lubricated for life										
Direction of rotation			In- and output same direction										
Protection class			IP 64										
Elastomer coupling (recommended product type – validate sizing with cymex®)			ELC-0005BA012.000-X										
Bore diameter of coupling on the application side		mm	X = 004.000 - 012.700										
Mass moment of inertia (relates to the drive) Clamping hub diameter [mm]	Z	8	J_1	kgcm ²	0.03	0.03	0.03	0.03	0.03	0.02	0.02	0.02	0.02
				10 ⁻³ in.lb.s ²	0.03	0.03	0.03	0.03	0.03	0.02	0.02	0.02	0.02
	A	9	J_1	kgcm ²	0.03	0.03	0.02	0.03	0.03	0.02	0.02	0.02	0.02
				10 ⁻³ in.lb.s ²	0.03	0.03	0.02	0.03	0.03	0.02	0.02	0.02	0.02
	B	11	J_1	kgcm ²	0.05	0.05	0.04	0.05	0.04	0.04	0.04	0.04	0.04
				10 ⁻³ in.lb.s ²	0.04	0.04	0.04	0.04	0.04	0.04	0.04	0.04	0.04
	C	14	J_1	kgcm ²	0.13	0.13	0.13	0.13	0.13	0.13	0.13	0.13	0.13
				10 ⁻³ in.lb.s ²	0.12	0.12	0.12	0.12	0.12	0.12	0.12	0.12	0.12

Please use our sizing software cymex® for a detailed sizing – www.wittenstein-cymex.com

^{a)} Valid for torque transmission only

^{b)} Valid for standard clamping hub diameter

^{c)} Refers to center of the output shaft or flange

^{d)} Please reduce input speed at higher ambient temperatures

^{e)} Valid for: Smooth shaft

2-stage

up to 11⁴⁾ (B)⁵⁾
clamping hub
diameter

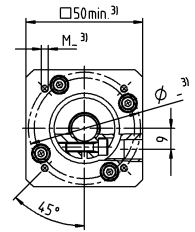
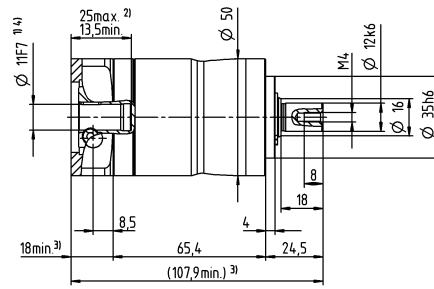
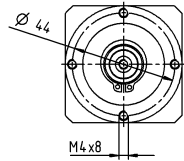

Motor shaft diameter [mm]

up to 14⁴⁾ (C)
clamping hub
diameter

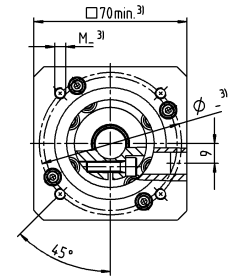
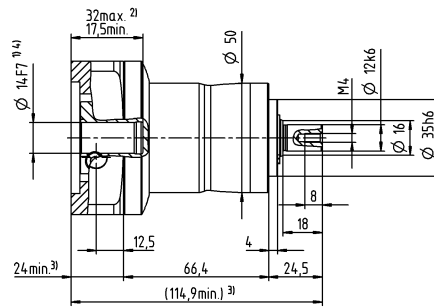
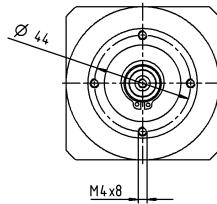

Planetary Gearboxes
Value Line

Other output variants

Shaft with key

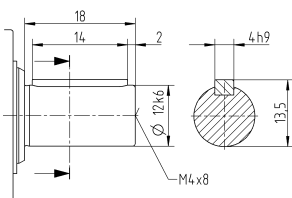

Non-tolerated dimensions are nominal dimensions

¹⁾ Check motor shaft fit

²⁾ Min. / Max. permissible motor shaft length

Longer motor shafts are possible, please contact alpha

³⁾ The dimensions depend on the motor

⁴⁾ Smaller motor shaft diameter is compensated

by a bushing with a minimum wall thickness of 1 mm

⁵⁾ Standard clamping hub diameter

NP 015 MF 1-stage

			1-stage							
Ratio	i		3	4	5	7	8	10		
Max. torque ^{a) b) e)}	T_{2a}	Nm	51	56	64	64	56	56		
		in.lb	451	496	566	566	496	496		
Max. acceleration torque ^{e)} (max. 1000 cycles per hour)	T_{2B}	Nm	32	35	40	40	35	35		
		in.lb	283	310	354	354	310	310		
Emergency stop torque ^{a) b) e)} (permitted 1000 times during the service life of the gearbox)	T_{2Not}	Nm	80	80	80	80	80	80		
		in.lb	708	708	708	708	708	708		
Permitted average input speed ^{d)} (at T_{2N} and 20 °C ambient temperature)	n_{1N}	rpm	3300	3500	3700	4000	4100	4300		
Max. input speed	n_{1Max}	rpm	8000	8000	8000	8000	8000	8000		
Mean no load running torque ^{b)} (at $n_1=3000$ rpm and 20 °C gearbox temperature)	T_{012}	Nm	0.24	0.2	0.17	0.14	0.13	0.12		
		in.lb	2.1	1.8	1.5	1.2	1.2	1.1		
Max. backlash	j_l	arcmin	≤ 8							
Torsional rigidity ^{b)}	C_{121}	Nm/arcmin	3.3	3.3	3.3	3.3	2.8	2.8		
		in.lb/arcmin	29	29	29	29	25	25		
Max. axial force ^{c)}	F_{2AMax}	N	1550							
		lb _f	349							
Max. lateral force ^{c)}	F_{2QMMax}	N	1700							
		lb _f	383							
Max. tilting moment	M_{2KMMax}	Nm	72							
		in.lb	637							
Efficiency at full load	η	%	97							
Service life	L_n	h	> 20000							
Weight (incl. standard adapter plate)	m	kg	1.9							
		lb _m	4.2							
Operating noise (at reference ratio and reference speed – ratio-specific values available in cymex [®])	L_{PA}	dB(A)	≤ 59							
Max. permitted housing temperature		°C	+90							
		°F	+194							
Ambient temperature		°C	-15 to +40							
		°F	+5 to +104							
Lubrication			Lubricated for life							
Direction of rotation			In- and output same direction							
Protection class			IP 64							
Elastomer coupling (recommended product type – validate sizing with cymex [®])			ELC-0060BA016.000-X							
Bore diameter of coupling on the application side		mm	X = 012.000 - 032.000							
Mass moment of inertia (relates to the drive) Clamping hub diameter [mm]	A	9	J_1	kgcm ²	0.22	0.18	0.16	0.14	0.14	0.13
				10 ⁻³ in.lb.s ²	0.19	0.16	0.14	0.12	0.12	0.12
	B	11	J_1	kgcm ²	0.24	0.19	0.18	0.16	0.15	0.15
				10 ⁻³ in.lb.s ²	0.21	0.17	0.16	0.14	0.13	0.13
	C	14	J_1	kgcm ²	0.32	0.27	0.25	0.23	0.23	0.22
				10 ⁻³ in.lb.s ²	0.28	0.24	0.22	0.2	0.2	0.19
	D	16	J_1	kgcm ²	0.45	0.4	0.38	0.36	0.36	0.35
				10 ⁻³ in.lb.s ²	0.4	0.35	0.34	0.32	0.32	0.31
	E	19	J_1	kgcm ²	0.53	0.48	0.46	0.44	0.44	0.43
				10 ⁻³ in.lb.s ²	0.47	0.42	0.41	0.39	0.39	0.38

Please use our sizing software cymex[®] for a detailed sizing – www.wittenstein-cymex.com

^{a)} Valid for torque transmission only

^{b)} Valid for standard clamping hub diameter

^{c)} Refers to center of the output shaft or flange

^{d)} Please reduce input speed at higher ambient temperatures

^{e)} Valid for: Smooth shaft

1-stage

up to 14⁴⁾ (C)⁵⁾
clamping hub diameter

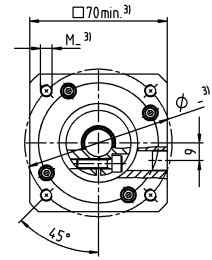
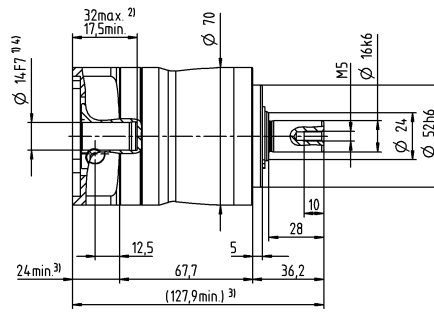
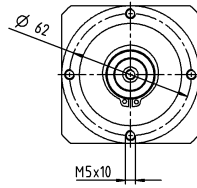

Motor shaft diameter [mm]

up to 19⁴⁾ (E)
clamping hub diameter

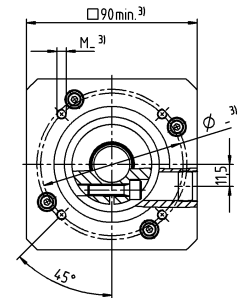
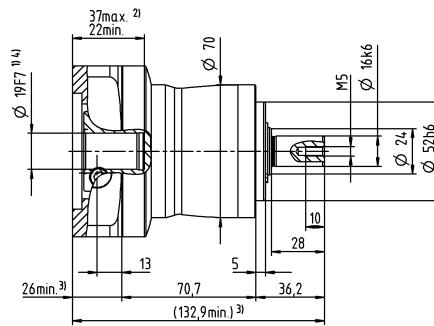
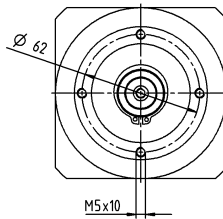

Other output variants

Shaft with key

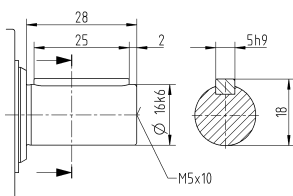

Non-tolerated dimensions are nominal dimensions

¹⁾ Check motor shaft fit

²⁾ Min. / Max. permissible motor shaft length

Longer motor shafts are possible, please contact alpha

³⁾ The dimensions depend on the motor

⁴⁾ Smaller motor shaft diameter is compensated by a bushing with a minimum wall thickness of 1 mm

⁵⁾ Standard clamping hub diameter

NP 015 MF 2-stage

			2-stage														
Ratio	i		12	15	16	20	25	28	30	32	35	40	50	64	70	100	
Max. torque ^{a) b) e)}	T_{2a}	Nm	51	51	56	56	64	56	51	56	64	56	64	56	64	56	
		in.lb	451	451	496	496	566	496	451	496	566	496	566	496	566	496	566
Max. acceleration torque ^{e)} (max. 1000 cycles per hour)	T_{2B}	Nm	32	32	35	35	40	35	32	35	40	35	40	35	40	35	
		in.lb	283	283	310	310	354	310	283	310	354	310	354	310	354	310	
Emergency stop torque ^{a) b) e)} (permitted 1000 times during the service life of the gearbox)	T_{2Not}	Nm	80	80	80	80	80	80	80	80	80	80	80	80	80	80	
		in.lb	708	708	708	708	708	708	708	708	708	708	708	708	708	708	
Permitted average input speed ^{d)} (at T_{2N} and 20 °C ambient temperature)	n_{1N}	rpm	3800	4000	3800	4000	4000	4300	4600	4400	4300	4600	4600	4400	4600	4600	
Max. input speed	n_{1Max}	rpm	10000	10000	10000	10000	10000	10000	10000	10000	10000	10000	10000	10000	10000	10000	
Mean no load running torque ^{b)} (at $n_1=3000$ rpm and 20 °C gearbox temperature)	T_{012}	Nm	0.13	0.11	0.12	0.11	0.1	0.09	0.09	0.09	0.09	0.08	0.08	0.08	0.08	0.08	
		in.lb	1.2	0.97	1.1	0.97	0.89	0.8	0.8	0.8	0.8	0.71	0.71	0.71	0.71	0.71	
Max. backlash	j_l	arcmin	≤ 10														
Torsional rigidity ^{b)}	C_{i21}	Nm/arcmin	3.3	3.3	3.3	3.3	3.3	3.3	4	3.3	3.3	3.3	3.3	2.8	3.3	2.8	
		in.lb/arcmin	29	29	29	29	29	29	35	29	29	29	29	25	29	25	
Max. axial force ^{c)}	F_{2AMax}	N	1550														
		lb _f	349														
Max. lateral force ^{c)}	F_{2QMMax}	N	1700														
		lb _f	383														
Max. tilting moment	M_{2KMMax}	Nm	72														
		in.lb	637														
Efficiency at full load	η	%	95														
Service life	L_n	h	> 20000														
Weight (incl. standard adapter plate)	m	kg	1.9														
		lb _m	4.2														
Operating noise (at reference ratio and reference speed – ratio-specific values available in cymex [®])	L_{PA}	dB(A)	≤ 58														
Max. permitted housing temperature		°C	+90														
		°F	+194														
Ambient temperature		°C	-15 to +40														
		°F	+5 to +104														
Lubrication			Lubricated for life														
Direction of rotation			In- and output same direction														
Protection class			IP 64														
Elastomer coupling (recommended product type – validate sizing with cymex [®])			ELC-0060BA016.000-X														
Bore diameter of coupling on the application side		mm	X = 012.000 - 032.000														
Mass moment of inertia (relates to the drive) Clamping hub diameter [mm]	Z	8	J_1	kgcm ²	0.04	0.04	0.03	0.03	0.03	0.03	0.03	0.03	0.03	0.02	0.02	0.02	0.02
				10 ⁻³ in.lb.s ²	0.04	0.04	0.03	0.03	0.03	0.03	0.03	0.03	0.03	0.03	0.02	0.02	0.02
	A	9	J_1	kgcm ²	0.04	0.04	0.03	0.03	0.03	0.03	0.03	0.03	0.03	0.02	0.02	0.02	0.02
				10 ⁻³ in.lb.s ²	0.04	0.04	0.03	0.03	0.03	0.03	0.03	0.03	0.03	0.02	0.02	0.02	0.02
	B	11	J_1	kgcm ²	0.06	0.05	0.05	0.05	0.05	0.05	0.05	0.04	0.05	0.04	0.04	0.04	
				10 ⁻³ in.lb.s ²	0.05	0.04	0.04	0.04	0.04	0.04	0.04	0.04	0.04	0.04	0.04	0.04	
	C	14	J_1	kgcm ²	0.14	0.14	0.14	0.13	0.13	0.13	0.14	0.13	0.13	0.13	0.13	0.13	
				10 ⁻³ in.lb.s ²	0.12	0.12	0.12	0.12	0.12	0.12	0.12	0.12	0.12	0.12	0.12	0.12	

Please use our sizing software cymex[®] for a detailed sizing – www.wittenstein-cymex.com

^{a)} Valid for torque transmission only

^{b)} Valid for standard clamping hub diameter

^{c)} Refers to center of the output shaft or flange

^{d)} Please reduce input speed at higher ambient temperatures

^{e)} Valid for: Smooth shaft

2-stage

Motor shaft diameter [mm]

up to 11⁴⁾ (B)⁵⁾
clamping hub diameter

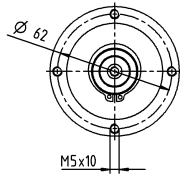

up to 14⁴⁾ (C)
clamping hub diameter

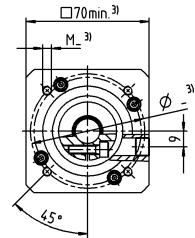
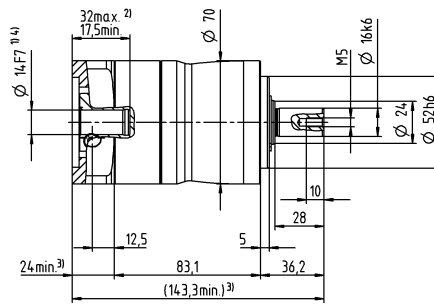
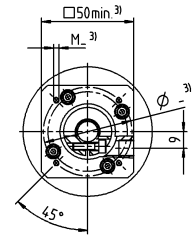
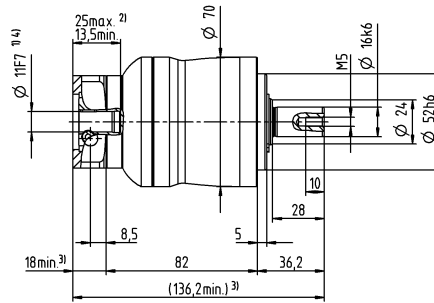
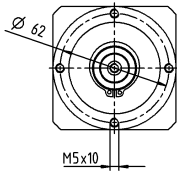

Other output variants

Shaft with key

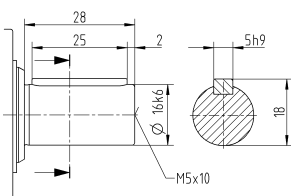

Non-tolerated dimensions are nominal dimensions

¹⁾ Check motor shaft fit

²⁾ Min. / Max. permissible motor shaft length

Longer motor shafts are possible, please contact alpha

³⁾ The dimensions depend on the motor

⁴⁾ Smaller motor shaft diameter is compensated

by a bushing with a minimum wall thickness of 1 mm

⁵⁾ Standard clamping hub diameter

NP 025 MF 1-stage

			1-stage							
Ratio	i		3	4	5	7	8	10		
Max. torque ^{a) b) e)}	T_{2a}	Nm	128	152	160	160	144	144		
		in.lb	1133	1345	1416	1416	1275	1275		
Max. acceleration torque ^{e)} (max. 1000 cycles per hour)	T_{2B}	Nm	80	95	100	100	90	90		
		in.lb	708	841	885	885	797	797		
Emergency stop torque ^{a) b) e)} (permitted 1000 times during the service life of the gearbox)	T_{2Not}	Nm	190	190	190	190	190	190		
		in.lb	1682	1682	1682	1682	1682	1682		
Permitted average input speed ^{d)} (at T_{2N} and 20 °C ambient temperature)	n_{1N}	rpm	3100	3300	3400	3600	3700	3900		
Max. input speed	n_{1Max}	rpm	7000	7000	7000	7000	7000	7000		
Mean no load running torque ^{b)} (at $n_1=3000$ rpm and 20 °C gearbox temperature)	T_{012}	Nm	0.38	0.31	0.26	0.21	0.19	0.17		
		in.lb	3.4	2.7	2.3	1.9	1.7	1.5		
Max. backlash	j_l	arcmin	≤ 8							
Torsional rigidity ^{b)}	C_{i21}	Nm/arcmin	9.5	9.5	9.5	9.5	8.5	8.5		
		in.lb/arcmin	84	84	84	84	75	75		
Max. axial force ^{c)}	F_{2AMax}	N	1900							
		lb _f	428							
Max. lateral force ^{c)}	F_{2QMMax}	N	2800							
		lb _f	630							
Max. tilting moment	M_{2KMMax}	Nm	137							
		in.lb	1213							
Efficiency at full load	η	%	97							
Service life	L_n	h	> 20000							
Weight (incl. standard adapter plate)	m	kg	3.8							
		lb _m	8.4							
Operating noise (at reference ratio and reference speed – ratio-specific values available in cymex [®])	L_{PA}	dB(A)	≤ 61							
Max. permitted housing temperature		°C	+90							
		°F	+194							
Ambient temperature		°C	-15 to +40							
		°F	+5 to +104							
Lubrication			Lubricated for life							
Direction of rotation			In- and output same direction							
Protection class			IP 64							
Elastomer coupling (recommended product type – validate sizing with cymex [®])			ELC-0060BA022.000-X							
Bore diameter of coupling on the application side		mm	X = 012.000 - 032.000							
Mass moment of inertia (relates to the drive) Clamping hub diameter [mm]	C	14	J_1	kgcm ²	0.57	0.46	0.37	0.3	0.27	0.25
				10 ⁻³ in.lb.s ²	0.5	0.41	0.33	0.27	0.24	0.22
	D	16	J_1	kgcm ²	0.71	0.61	0.52	0.43	0.42	0.4
				10 ⁻³ in.lb.s ²	0.63	0.54	0.46	0.38	0.37	0.35
	E	19	J_1	kgcm ²	0.8	0.7	0.61	0.53	0.51	0.49
				10 ⁻³ in.lb.s ²	0.71	0.62	0.54	0.47	0.45	0.43
	G	24	J_1	kgcm ²	1.8	1.7	1.6	1.6	1.5	1.5
				10 ⁻³ in.lb.s ²	1.6	1.5	1.4	1.4	1.3	1.3
	H	28	J_1	kgcm ²	1.5	1.4	1.3	1.3	1.2	1.2
				10 ⁻³ in.lb.s ²	1.3	1.2	1.2	1.2	1.1	1.1

Please use our sizing software cymex[®] for a detailed sizing – www.wittenstein-cymex.com

^{a)} Valid for torque transmission only

^{b)} Valid for standard clamping hub diameter

^{c)} Refers to center of the output shaft or flange

^{d)} Please reduce input speed at higher ambient temperatures

^{e)} Valid for: Smooth shaft

1-stage

up to 19⁴⁾ (E)⁵⁾
clamping hub
diameter

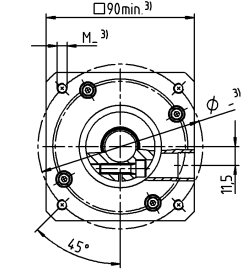
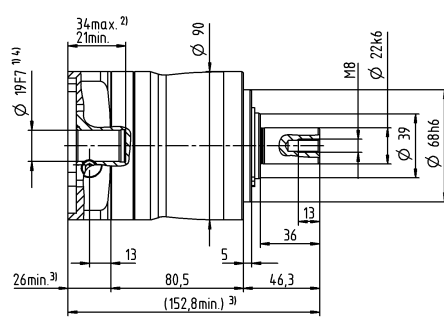
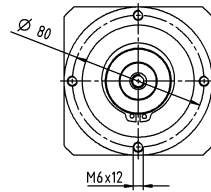

Motor shaft diameter [mm]

up to 28⁴⁾ (H)
clamping hub
diameter

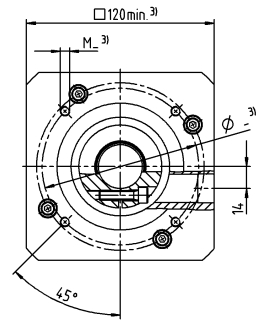
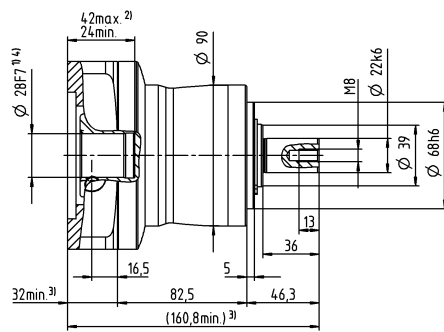
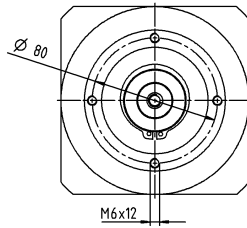

Planetary Gearboxes
Value Line

Other output variants

Shaft with key

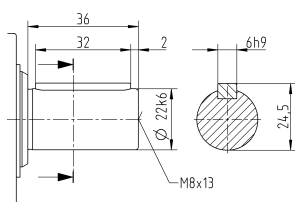

Non-tolerated dimensions are nominal dimensions

¹⁾ Check motor shaft fit

²⁾ Min. / Max. permissible motor shaft length

Longer motor shafts are possible, please contact alpha

³⁾ The dimensions depend on the motor

⁴⁾ Smaller motor shaft diameter is compensated

by a bushing with a minimum wall thickness of 1 mm

⁵⁾ Standard clamping hub diameter

NP 025 MF 2-stage

			2-stage														
Ratio	i		9	12	15	16	20	25	28	30	32	35	40	50	64	70	100
Max. torque ^{a) b) e)}	T_{2a}	Nm	128	128	128	152	152	160	152	128	152	160	152	160	144	160	144
		in.lb	1133	1133	1133	1345	1345	1416	1345	1133	1345	1416	1345	1416	1275	1416	1275
Max. acceleration torque ^{e)} (max. 1000 cycles per hour)	T_{2B}	Nm	80	80	80	95	95	100	95	80	95	100	95	100	90	100	90
		in.lb	708	708	708	841	841	885	841	708	841	885	841	885	797	885	797
Emergency stop torque ^{a) b) e)} (permitted 1000 times during the service life of the gearbox)	T_{2Not}	Nm	190	190	190	190	190	190	190	190	190	190	190	190	190	190	190
		in.lb	1682	1682	1682	1682	1682	1682	1682	1682	1682	1682	1682	1682	1682	1682	1682
Permitted average input speed ^{d)} (at T_{2N} and 20 °C ambient temperature)	n_{1N}	rpm	3300	3500	3700	3500	3700	3700	4000	4300	4100	4000	4300	4300	4100	4300	4300
Max. input speed	n_{1Max}	rpm	8000	8000	8000	8000	8000	8000	8000	8000	8000	8000	8000	8000	8000	8000	8000
Mean no load running torque ^{b)} (at $n_1=3000$ rpm and 20 °C gearbox temperature)	T_{012}	Nm	0.22	0.18	0.16	0.16	0.15	0.14	0.12	0.12	0.12	0.12	0.11	0.1	0.1	0.1	0.09
		in.lb	1.9	1.6	1.4	1.4	1.3	1.2	1.1	1.1	1.1	1.1	0.97	0.89	0.89	0.89	0.8
Max. backlash	j_t	arcmin	≤ 10														
Torsional rigidity ^{b)}	C_{t21}	Nm/arcmin	9.5	9.5	9.5	9.5	9.5	9.5	9.5	9.5	9.5	9.5	9.5	9.5	8.5	9.5	8.5
		in.lb/arcmin	84	84	84	84	84	84	84	84	84	84	84	84	75	84	75
Max. axial force ^{c)}	F_{2AMax}	N	1900														
		lb _f	428														
Max. lateral force ^{c)}	F_{2QMMax}	N	2800														
		lb _f	630														
Max. tilting moment	M_{2KMMax}	Nm	137														
		in.lb	1213														
Efficiency at full load	η	%	95														
Service life	L_n	h	> 20000														
Weight (incl. standard adapter plate)	m	kg	4.1														
		lb _m	9.1														
Operating noise (at reference ratio and reference speed – ratio-specific values available in cymex [®])	L_{PA}	dB(A)	≤ 59														
Max. permitted housing temperature		°C	+90														
		°F	+194														
Ambient temperature		°C	-15 to +40														
		°F	+5 to +104														
Lubrication			Lubricated for life														
Direction of rotation			In- and output same direction														
Protection class			IP 64														
Elastomer coupling (recommended product type – validate sizing with cymex [®])			ELC-0060BA022.000-X														
Bore diameter of coupling on the application side		mm	X = 012.000 - 032.000														
Mass moment of inertia (relates to the drive) Clamping hub diameter [mm]	A	9	J_t	kgcm ²	0.26	0.22	0.21	0.21	0.2	0.2	0.19	0.19	0.19	0.19	0.19	0.19	0.19
				10 ⁻³ in.lb.s ²	0.23	0.19	0.19	0.19	0.18	0.18	0.17	0.17	0.17	0.17	0.17	0.17	0.17
	B	11	J_t	kgcm ²	0.28	0.24	0.23	0.23	0.22	0.22	0.21	0.21	0.21	0.21	0.21	0.21	0.21
				10 ⁻³ in.lb.s ²	0.25	0.21	0.2	0.2	0.19	0.19	0.19	0.19	0.19	0.19	0.19	0.19	0.19
	C	14	J_t	kgcm ²	0.35	0.31	0.3	0.3	0.3	0.29	0.29	0.28	0.28	0.28	0.28	0.28	0.28
				10 ⁻³ in.lb.s ²	0.31	0.27	0.27	0.27	0.27	0.26	0.26	0.25	0.25	0.25	0.25	0.25	0.25
	D	16	J_t	kgcm ²	0.48	0.44	0.43	0.43	0.42	0.42	0.41	0.41	0.41	0.41	0.41	0.41	0.41
				10 ⁻³ in.lb.s ²	0.42	0.39	0.38	0.38	0.37	0.37	0.36	0.36	0.36	0.36	0.36	0.36	0.36
	E	19	J_t	kgcm ²	0.56	0.52	0.51	0.51	0.51	0.5	0.5	0.5	0.5	0.5	0.49	0.49	0.49
				10 ⁻³ in.lb.s ²	0.5	0.46	0.45	0.45	0.45	0.44	0.44	0.44	0.44	0.44	0.43	0.43	0.43

Please use our sizing software cymex[®] for a detailed sizing – www.wittenstein-cymex.com

^{a)} Valid for torque transmission only

^{b)} Valid for standard clamping hub diameter

^{c)} Refers to center of the output shaft or flange

^{d)} Please reduce input speed at higher ambient temperatures

^{e)} Valid for: Smooth shaft

2-stage

up to 14⁴⁾ (C)⁵⁾
clamping hub diameter

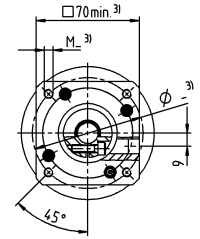
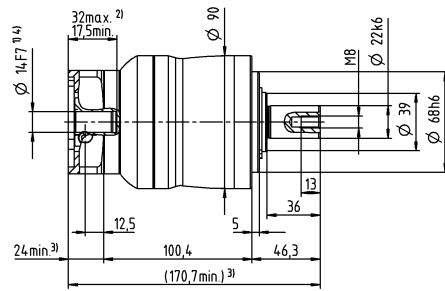
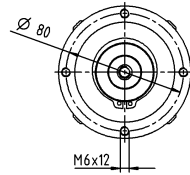

Motor shaft diameter [mm]

up to 19⁴⁾ (E)
clamping hub diameter

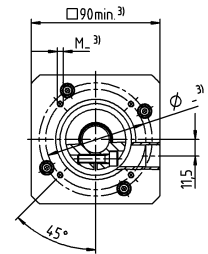
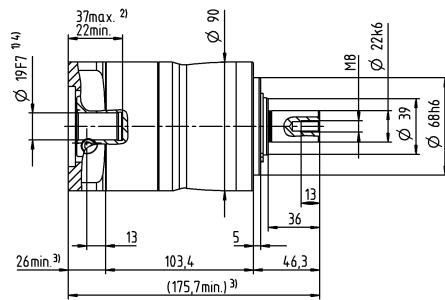
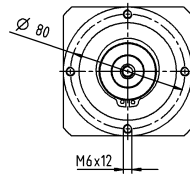

Other output variants

Shaft with key

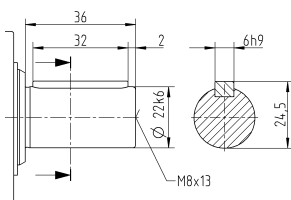

Non-tolerated dimensions are nominal dimensions

¹⁾ Check motor shaft fit

²⁾ Min. / Max. permissible motor shaft length

Longer motor shafts are possible, please contact alpha

³⁾ The dimensions depend on the motor

⁴⁾ Smaller motor shaft diameter is compensated by a bushing with a minimum wall thickness of 1 mm

⁵⁾ Standard clamping hub diameter

NP 035 MF 1-stage

			1-stage							
Ratio	i		3	4	5	7	8	10		
Max. torque ^{a) b) e)}	T_{2a}	Nm	320	408	400	400	352	352		
		in.lb	2832	3611	3540	3540	3115	3115		
Max. acceleration torque ^{e)} (max. 1000 cycles per hour)	T_{2B}	Nm	200	255	250	250	220	220		
		in.lb	1770	2257	2213	2213	1947	1947		
Emergency stop torque ^{a) b) e)} (permitted 1000 times during the service life of the gearbox)	T_{2Not}	Nm	500	500	500	500	500	500		
		in.lb	4425	4425	4425	4425	4425	4425		
Permitted average input speed ^{d)} (at T_{2a} and 20 °C ambient temperature)	n_{1N}	rpm	2300	2500	2600	2800	2900	3000		
Max. input speed	n_{1Max}	rpm	6000	6000	6000	6000	6000	6000		
Mean no load running torque ^{b)} (at $n_1=3000$ rpm and 20 °C gearbox temperature)	T_{012}	Nm	1	0.85	0.76	0.66	0.63	0.58		
		in.lb	8.9	7.5	6.7	5.8	5.6	5.1		
Max. backlash	j_l	arcmin	≤ 8							
Torsional rigidity ^{b)}	C_{t21}	Nm/arcmin	22	25	25	25	22	22		
		in.lb/arcmin	195	221	221	221	195	195		
Max. axial force ^{c)}	F_{2AMax}	N	4000							
		lb _f	900							
Max. lateral force ^{c)}	F_{2QMMax}	N	5000							
		lb _f	1125							
Max. tilting moment	M_{2KMMax}	Nm	345							
		in.lb	3054							
Efficiency at full load	η	%	97							
Service life	L_n	h	> 20000							
Weight (incl. standard adapter plate)	m	kg	9.4							
		lb _m	21							
Operating noise (at reference ratio and reference speed – ratio-specific values available in cymex [®])	L_{PA}	dB(A)	≤ 65							
Max. permitted housing temperature		°C	+90							
		°F	+194							
Ambient temperature		°C	-15 to +40							
		°F	+5 to +104							
Lubrication			Lubricated for life							
Direction of rotation			In- and output same direction							
Protection class			IP 64							
Elastomer coupling (recommended product type – validate sizing with cymex [®])			ELC-0150BA032.000-X							
Bore diameter of coupling on the application side		mm	X = 019.000 - 036.000							
Mass moment of inertia (relates to the drive) Clamping hub diameter [mm]	E	19	J_1	kgcm ²	2.6	1.7	1.4	1	1	0.9
				10 ⁻³ in.lb.s ²	2.3	1.5	1.2	0.89	0.89	0.8
	G	24	J_1	kgcm ²	3.4	2.5	2.2	1.8	1.7	1.7
				10 ⁻³ in.lb.s ²	3	2.2	1.9	1.6	1.5	1.5
	H	28	J_1	kgcm ²	3.1	2.2	1.9	1.5	1.4	1.4
				10 ⁻³ in.lb.s ²	2.7	1.9	1.7	1.3	1.2	1.2
	I	32	J_1	kgcm ²	7.2	6.3	5.9	5.6	5.5	5.4
				10 ⁻³ in.lb.s ²	6.4	5.6	5.2	5	4.9	4.8
	K	38	J_1	kgcm ²	8.3	7.4	7.1	6.8	6.7	6.6
				10 ⁻³ in.lb.s ²	7.3	6.5	6.3	6	5.9	5.8

Please use our sizing software cymex[®] for a detailed sizing – www.wittenstein-cymex.com

^{a)} Valid for torque transmission only

^{b)} Valid for standard clamping hub diameter

^{c)} Refers to center of the output shaft or flange

^{d)} Please reduce input speed at higher ambient temperatures

^{e)} Valid for: Smooth shaft

1-stage

Motor shaft diameter [mm]

up to 24/28⁴⁾
(G⁵⁾/H)
clamping hub diameter

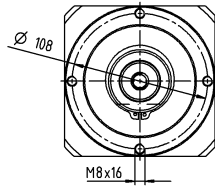

up to 38⁴⁾ (K)
clamping hub diameter

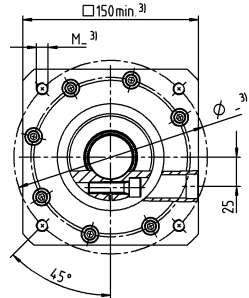
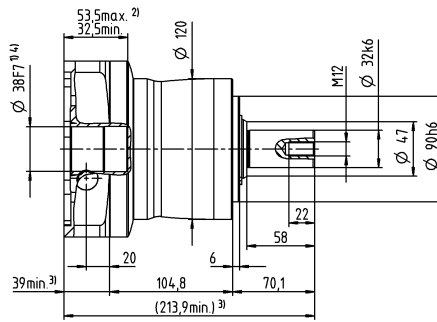
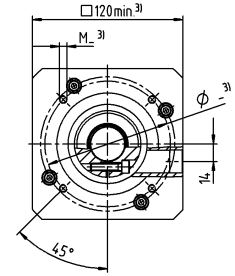
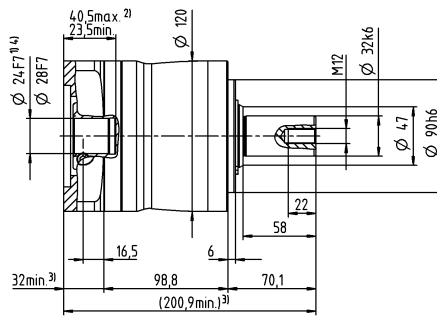
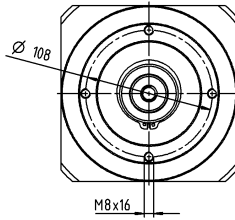

Other output variants

Shaft with key

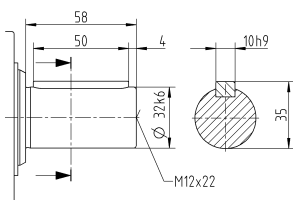

Non-tolerated dimensions are nominal dimensions

¹⁾ Check motor shaft fit

²⁾ Min. / Max. permissible motor shaft length

Longer motor shafts are possible, please contact alpha

³⁾ The dimensions depend on the motor

⁴⁾ Smaller motor shaft diameter is compensated by a bushing with a minimum wall thickness of 1 mm

⁵⁾ Standard clamping hub diameter

NP 035 MF 2-stage

			2-stage																
Ratio	i		9	12	15	16	20	25	28	30	32	35	40	50	64	70	100		
Max. torque ^{a) b) e)}	T_{2a}	Nm	320	320	320	408	408	400	408	320	408	400	408	400	352	400	352		
		in.lb	2832	2832	2832	3611	3611	3540	3611	2832	3611	3540	3611	3540	3115	3540	3115		
Max. acceleration torque ^{e)} (max. 1000 cycles per hour)	T_{2B}	Nm	200	200	200	255	255	250	255	200	255	250	255	250	220	250	220		
		in.lb	1770	1770	1770	2257	2257	2213	2257	1770	2257	2213	2257	2213	1947	2213	1947		
Emergency stop torque ^{a) b) e)} (permitted 1000 times during the service life of the gearbox)	T_{2Not}	Nm	500	500	500	500	500	500	500	500	500	500	500	500	500	500	500		
		in.lb	4425	4425	4425	4425	4425	4425	4425	4425	4425	4425	4425	4425	4425	4425	4425		
Permitted average input speed ^{d)} (at T_{2a} and 20 °C ambient temperature)	n_{1N}	rpm	3100	3300	3400	3300	3400	3400	3600	3900	3700	3600	3900	3900	3700	3900	3900		
Max. input speed	n_{1Max}	rpm	7000	7000	7000	7000	7000	7000	7000	7000	7000	7000	7000	7000	7000	7000	7000		
Mean no load running torque ^{b)} (at $n_1=3000$ rpm and 20 °C gearbox temperature)	T_{012}	Nm	0.45	0.36	0.3	0.32	0.27	0.25	0.22	0.19	0.2	0.2	0.18	0.17	0.17	0.16	0.15		
		in.lb	4	3.2	2.7	2.8	2.4	2.2	1.9	1.7	1.8	1.8	1.6	1.5	1.5	1.4	1.3		
Max. backlash	j_l	arcmin	≤ 10																
Torsional rigidity ^{b)}	C_{121}	Nm/arcmin	22	22	22	25	25	25	25	22	25	25	25	25	22	25	22		
		in.lb/arcmin	195	195	195	221	221	221	221	195	221	221	221	221	195	221	195		
Max. axial force ^{c)}	F_{2AMax}	N	4000																
		lb _f	900																
Max. lateral force ^{c)}	F_{2QMMax}	N	5000																
		lb _f	1125																
Max. tilting moment	M_{2KMMax}	Nm	345																
		in.lb	3054																
Efficiency at full load	η	%	95																
Service life	L_n	h	> 20000																
Weight (incl. standard adapter plate)	m	kg	9.8																
		lb _m	22																
Operating noise (at reference ratio and reference speed – ratio-specific values available in cymex®)	L_{PA}	dB(A)	≤ 61																
Max. permitted housing temperature		°C	+90																
		°F	+194																
Ambient temperature		°C	-15 to +40																
		°F	+5 to +104																
Lubrication			Lubricated for life																
Direction of rotation			In- and output same direction																
Protection class			IP 64																
Elastomer coupling (recommended product type – validate sizing with cymex®)			ELC-0150BA032.000-X																
Bore diameter of coupling on the application side		mm	X = 019.000 - 036.000																
Mass moment of inertia (relates to the drive) Clamping hub diameter [mm]	C	14	J_1	kgcm ²	0.61	0.6	0.6	0.43	0.42	0.36	0.37	0.52	0.38	0.32	0.36	0.31	0.26	0.27	0.24
				10 ⁻³ in.lb.s ²	0.54	0.53	0.53	0.38	0.37	0.32	0.33	0.46	0.34	0.28	0.32	0.27	0.23	0.24	0.21
	D	16	J_1	kgcm ²	0.76	0.75	0.75	0.58	0.57	0.5	0.5	0.67	0.52	0.45	0.51	0.46	0.4	0.41	0.39
				10 ⁻³ in.lb.s ²	0.67	0.66	0.66	0.51	0.5	0.44	0.44	0.59	0.46	0.4	0.45	0.41	0.35	0.36	0.35
	E	19	J_1	kgcm ²	0.85	0.83	0.83	0.67	0.66	0.59	0.6	0.75	0.61	0.55	0.6	0.54	0.49	0.5	0.48
				10 ⁻³ in.lb.s ²	0.75	0.73	0.73	0.59	0.58	0.52	0.53	0.66	0.54	0.49	0.53	0.48	0.43	0.44	0.42
	G	24	J_1	kgcm ²	1.9	1.9	1.9	1.7	1.7	1.6	1.6	1.8	1.6	1.6	1.6	1.6	1.5	1.5	1.5
				10 ⁻³ in.lb.s ²	1.7	1.7	1.7	1.5	1.5	1.4	1.4	1.6	1.4	1.4	1.4	1.4	1.4	1.3	1.3
	H	28	J_1	kgcm ²	1.6	1.6	1.6	1.4	1.4	1.3	1.3	1.5	1.4	1.3	1.3	1.3	1.2	1.2	1.2
				10 ⁻³ in.lb.s ²	1.4	1.4	1.4	1.2	1.2	1.2	1.2	1.3	1.2	1.2	1.2	1.2	1.1	1.1	1.1

Please use our sizing software cymex® for a detailed sizing – www.wittenstein-cymex.com

^{a)} Valid for torque transmission only

^{b)} Valid for standard clamping hub diameter

^{c)} Refers to center of the output shaft or flange

^{d)} Please reduce input speed at higher ambient temperatures

^{e)} Valid for: Smooth shaft

2-stage

Motor shaft diameter [mm]

up to 19⁴⁾ (E)⁵⁾
clamping hub diameter

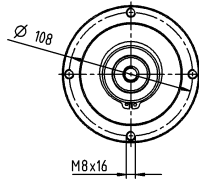

up to 28⁴⁾ (H)
clamping hub diameter

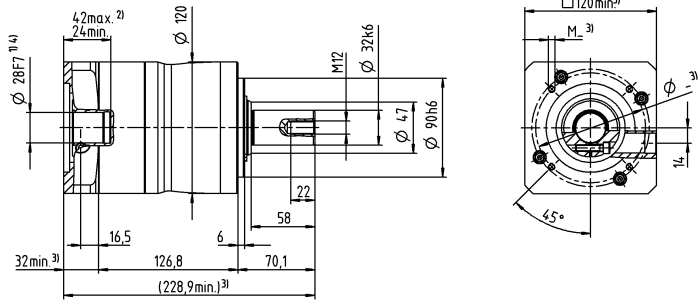
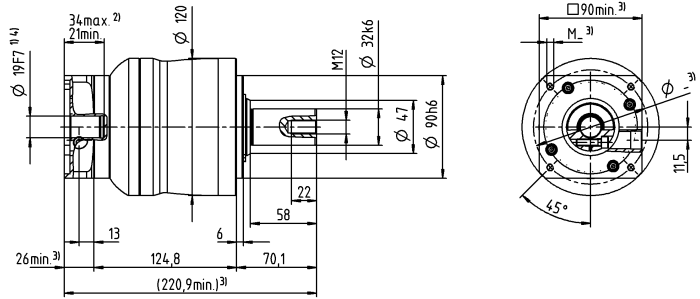
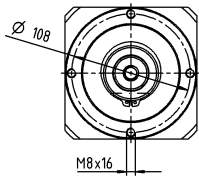

Other output variants

Shaft with key

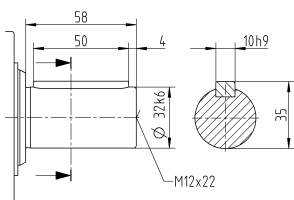

Non-tolerated dimensions are nominal dimensions

¹⁾ Check motor shaft fit

²⁾ Min. / Max. permissible motor shaft length

Longer motor shafts are possible, please contact alpha

³⁾ The dimensions depend on the motor

⁴⁾ Smaller motor shaft diameter is compensated

by a bushing with a minimum wall thickness of 1 mm

⁵⁾ Standard clamping hub diameter

NP 045 MF 1-/2-stage

			1-stage			2-stage						
Ratio	i		5	8	10	25	32	50	64	100		
Max. torque ^{a) b) e)}	T_{2a}	Nm	800	640	640	700	640	700	640	640		
		in.lb	7081	5665	5665	6196	5665	6196	5665	5665		
Max. acceleration torque ^{e)} (max. 1000 cycles per hour)	T_{2B}	Nm	500	400	400	500	400	500	400	400		
		in.lb	4425	3540	3540	4425	3540	4425	3540	3540		
Emergency stop torque ^{a) b) e)} (permitted 1000 times during the service life of the gearbox)	T_{2Not}	Nm	1000	1000	1000	1000	1000	1000	1000	1000		
		in.lb	8851	8851	8851	8851	8851	8851	8851	8851		
Permitted average input speed ^{d)} (at T_{2a} and 20 °C ambient temperature)	n_{1N}	rpm	2000	2200	2300	2600	2500	3000	2900	3000		
Max. input speed	n_{1Max}	rpm	4000	4000	4000	6000	6000	6000	6000	6000		
Mean no load running torque ^{b)} (at $n_1=3000$ rpm and 20 °C gearbox temperature)	T_{012}	Nm	2.4	2	1.9	0.8	0.68	0.6	0.6	0.55		
		in.lb	21	18	17	7.1	6	5.3	5.3	4.9		
Max. backlash	j_l	arcmin	≤ 8			≤ 10						
Torsional rigidity ^{b)}	C_{i21}	Nm/arcmin	55	44	44	55	55	55	44	44		
		in.lb/arcmin	487	389	389	487	487	487	389	389		
Max. axial force ^{c)}	F_{2AMax}	N	6000			6000						
		lb _f	1350			1350						
Max. lateral force ^{c)}	F_{2QMax}	N	8000			8000						
		lb _f	1800			1800						
Max. tilting moment	M_{2KMMax}	Nm	704			704						
		in.lb	6231			6231						
Efficiency at full load	η	%	97			95						
Service life	L_n	h	> 20000			> 20000						
Weight (incl. standard adapter plate)	m	kg	19			20						
		lb _m	42			44						
Operating noise (at reference ratio and reference speed – ratio-specific values available in cymex [®])	L_{PA}	dB(A)	≤ 68			≤ 65						
Max. permitted housing temperature		°C	+90			+90						
		°F	+194			+194						
Ambient temperature		°C	-15 to +40			-15 to +40						
		°F	+5 to +104			+5 to +104						
Lubrication			Lubricated for life									
Direction of rotation			In- and output same direction									
Protection class			IP 64									
Elastomer coupling (recommended product type – validate sizing with cymex [®])			ELC-0300BA040.000-X									
Bore diameter of coupling on the application side		mm	X = 020.000 - 045.000									
Mass moment of inertia (relates to the drive) Clamping hub diameter [mm]	E	19	J_1	kgcm ²	-	-	-	1.2	1.1	1.1	0.88	0.82
				10 ⁻³ in.lb.s ²	-	-	-	1.1	0.97	0.97	0.78	0.73
	G	24	J_1	kgcm ²	-	-	-	2	1.9	1.8	1.7	1.6
				10 ⁻³ in.lb.s ²	-	-	-	1.8	1.7	1.6	1.5	1.4
	H	28	J_1	kgcm ²	-	-	-	1.7	1.6	1.5	1.4	1.3
				10 ⁻³ in.lb.s ²	-	-	-	1.5	1.4	1.3	1.2	1.2
	I	32	J_1	kgcm ²	-	-	-	5.8	5.7	5.6	5.4	5.4
				10 ⁻³ in.lb.s ²	-	-	-	5.1	5	5	4.8	4.8
	K	38	J_1	kgcm ²	8.8	7.4	7.2	7	6.9	6.8	6.6	6.5
				10 ⁻³ in.lb.s ²	7.8	6.5	6.4	6.2	6.1	6	5.8	5.8

Please use our sizing software cymex[®] for a detailed sizing – www.wittenstein-cymex.com

^{a)} Valid for torque transmission only

^{b)} Valid for standard clamping hub diameter

^{c)} Refers to center of the output shaft or flange

^{d)} Please reduce input speed at higher ambient temperatures

^{e)} Valid for: Smooth shaft

1-stage

up to 38⁴⁾ (K)⁵⁾
clamping hub
diameter

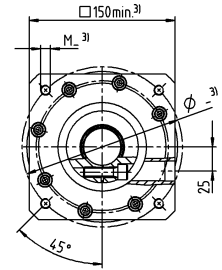
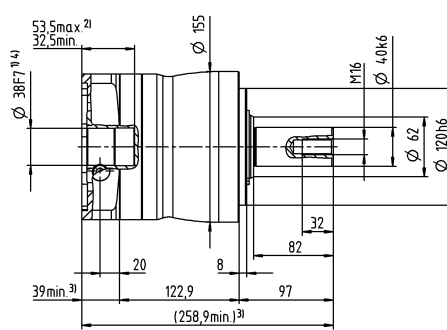
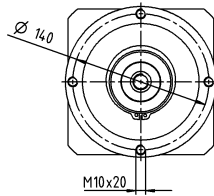

2-stage

up to 28⁴⁾ (H)⁵⁾
clamping hub
diameter

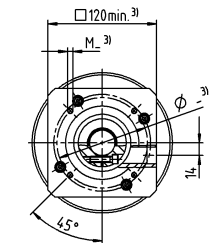
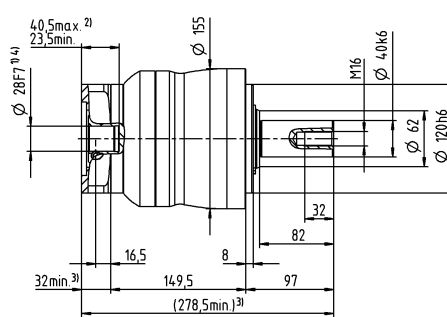
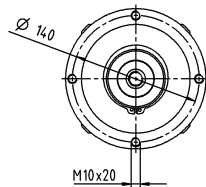

Motor shaft diameter [mm]

up to 38⁴⁾ (K)
clamping hub
diameter

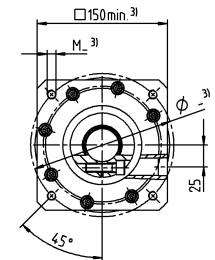
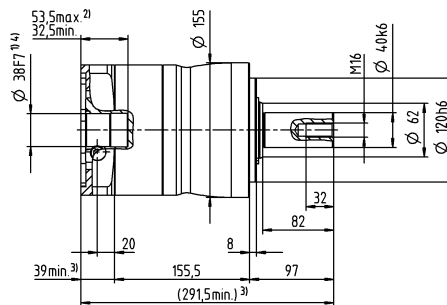
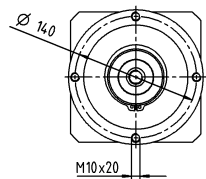

Planetary Gearboxes
Value Line

Other output variants

Shaft with key

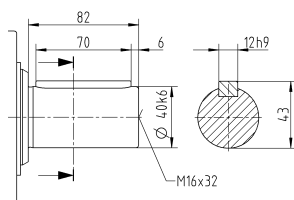

Non-tolerated dimensions are nominal dimensions

¹⁾ Check motor shaft fit

²⁾ Min. / Max. permissible motor shaft length

Longer motor shafts are possible, please contact alpha

³⁾ The dimensions depend on the motor

⁴⁾ Smaller motor shaft diameter is compensated

by a bushing with a minimum wall thickness of 1 mm

⁵⁾ Standard clamping hub diameter

NP 015 MA 1-/2-stage

			1-stage		2-stage							
Ratio	i		3	4	12	15	16	20	28	30	40	
Max. torque ^{a) b) e)}	T_{2a}	Nm	80	67	62	67	67	67	67	62	67	
		in.lb	708	593	549	593	593	593	593	593	549	593
Max. acceleration torque ^{e)} (max. 1000 cycles per hour)	T_{2B}	Nm	55	42	39	42	42	42	42	42	39	42
		in.lb	487	372	345	372	372	372	372	372	345	372
Emergency stop torque ^{a) b) e)} (permitted 1000 times during the service life of the gearbox)	T_{2Not}	Nm	80	80	80	80	80	80	80	80	80	80
		in.lb	708	708	708	708	708	708	708	708	708	708
Permitted average input speed ^{d)} (at T_{2m} and 20 °C ambient temperature)	n_{1N}	rpm	3300	3500	3800	4000	3800	4000	4300	4600	4600	
Max. input speed	n_{1Max}	rpm	8000	8000	10000	10000	10000	10000	10000	10000	10000	
Mean no load running torque ^{b)} (at $n_1=3000$ rpm and 20 °C gearbox temperature)	T_{012}	Nm	0.24	0.2	0.13	0.11	0.12	0.11	0.09	0.09	0.08	
		in.lb	2.1	1.8	1.2	0.97	1.1	0.97	0.8	0.8	0.71	
Max. backlash	j_l	arcmin	≤ 8		≤ 10							
Torsional rigidity ^{b)}	C_{t21}	Nm/arcmin	4	4	4	4	4	4	4	4	4	
		in.lb/arcmin	35	35	35	35	35	35	35	35	35	
Max. axial force ^{c)}	F_{2AMax}	N	1550		1550							
		lb _f	349		349							
Max. lateral force ^{c)}	F_{2QMMax}	N	1700		1700							
		lb _f	383		383							
Max. tilting moment	M_{2KMMax}	Nm	72		72							
		in.lb	637		637							
Efficiency at full load	η	%	97		95							
Service life	L_h	h	> 20000		> 20000							
Weight (incl. standard adapter plate)	m	kg	1.9		1.9							
		lb _m	4.2		4.2							
Operating noise (at reference ratio and reference speed – ratio-specific values available in cymex®)	L_{PA}	dB(A)	≤ 59		≤ 58							
Max. permitted housing temperature		°C	+90		+90							
		°F	+194		+194							
Ambient temperature		°C	-15 to +40		-15 to +40							
		°F	+5 to +104		+5 to +104							
Lubrication			Lubricated for life									
Direction of rotation			In- and output same direction									
Protection class			IP 64									
Elastomer coupling (recommended product type – validate sizing with cymex®)			ELC-0060BA016.000-X									
Bore diameter of coupling on the application side		mm	X = 012.000 - 032.000									
Mass moment of inertia (relates to the drive) Clamping hub diameter [mm]	Z	8	J_1	kgcm ²	-	-	0.04	0.04	0.03	0.03	0.03	0.03
				10 ⁻³ in.lb.s ²	-	-	0.04	0.04	0.03	0.03	0.03	0.03
	A	9	J_1	kgcm ²	0.22	0.18	0.04	0.04	0.03	0.03	0.03	0.03
				10 ⁻³ in.lb.s ²	0.19	0.16	0.04	0.04	0.03	0.03	0.03	0.03
	B	11	J_1	kgcm ²	0.24	0.19	0.06	0.05	0.05	0.05	0.05	0.05
				10 ⁻³ in.lb.s ²	0.21	0.17	0.05	0.04	0.04	0.04	0.04	0.04
	C	14	J_1	kgcm ²	0.32	0.27	0.14	0.14	0.14	0.13	0.13	0.14
				10 ⁻³ in.lb.s ²	0.28	0.24	0.12	0.12	0.12	0.12	0.12	0.12
	D	16	J_1	kgcm ²	0.45	0.4	-	-	-	-	-	-
				10 ⁻³ in.lb.s ²	0.4	0.35	-	-	-	-	-	-
	E	19	J_1	kgcm ²	0.53	0.48	-	-	-	-	-	-
				10 ⁻³ in.lb.s ²	0.47	0.42	-	-	-	-	-	-

Please use our sizing software cymex® for a detailed sizing – www.wittenstein-cymex.com

^{a)} Valid for torque transmission only

^{b)} Valid for standard clamping hub diameter

^{c)} Refers to center of the output shaft or flange

^{d)} Please reduce input speed at higher ambient temperatures

^{e)} Valid for: Smooth shaft

1-stage

up to 14⁴⁾ (C)⁵⁾
clamping hub diameter

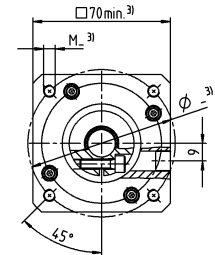
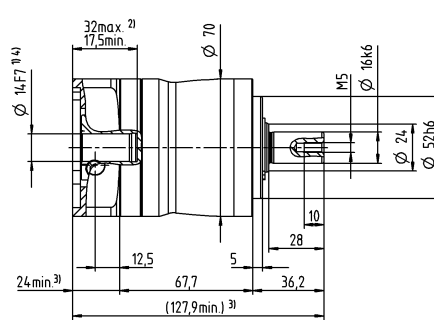
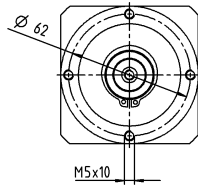

up to 19⁴⁾ (E)
clamping hub diameter

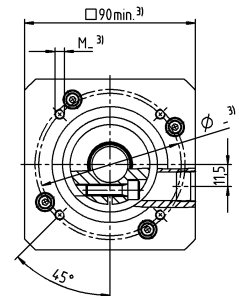
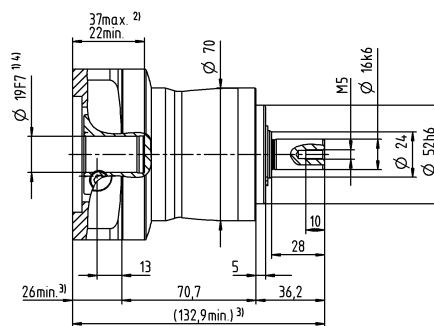
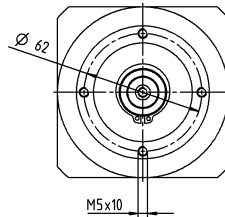

2-stage

up to 11⁴⁾ (B)⁵⁾
clamping hub diameter

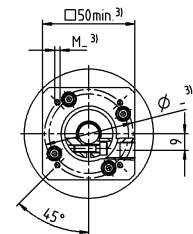
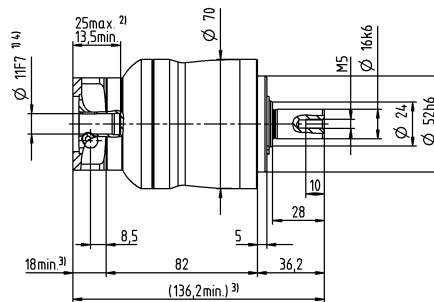
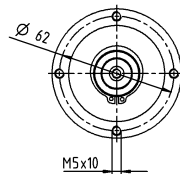

up to 14⁴⁾ (C)
clamping hub diameter

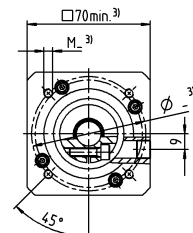
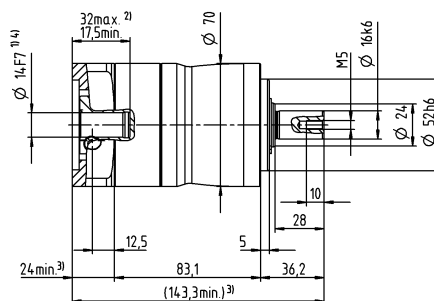
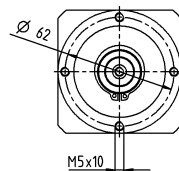

Motor shaft diameter [mm]

Other output variants

Shaft with key

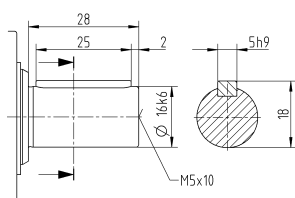

Non-tolerated dimensions are nominal dimensions

¹⁾ Check motor shaft fit

²⁾ Min. / Max. permissible motor shaft length

Longer motor shafts are possible, please contact alpha

³⁾ The dimensions depend on the motor

⁴⁾ Smaller motor shaft diameter is compensated

by a bushing with a minimum wall thickness of 1 mm

⁵⁾ Standard clamping hub diameter

NP 025 MA 1-/2-stage

			1-stage		2-stage									
Ratio	i		3	4	9	12	15	16	20	28	30	40		
Max. torque ^{a) b) e)}	T_{2a}	Nm	185	185	185	185	185	185	185	185	168	185		
		in.lb	1637	1637	1637	1637	1637	1637	1637	1637	1637	1487	1637	
Max. acceleration torque ^{e)} (max. 1000 cycles per hour)	T_{2B}	Nm	125	115	125	125	120	115	115	115	105	115		
		in.lb	1106	1018	1106	1106	1062	1018	1018	1018	929	1018		
Emergency stop torque ^{a) b) e)} (permitted 1000 times during the service life of the gearbox)	T_{2Not}	Nm	190	190	190	190	190	190	190	190	190	190		
		in.lb	1682	1682	1682	1682	1682	1682	1682	1682	1682	1682		
Permitted average input speed ^{d)} (at T_{2N} and 20 °C ambient temperature)	n_{1N}	rpm	3100	3300	3300	3500	3700	3500	3700	4000	4300	4300		
Max. input speed	n_{1Max}	rpm	7000	7000	8000	8000	8000	8000	8000	8000	8000	8000		
Mean no load running torque ^{b)} (at $n_1=3000$ rpm and 20 °C gearbox temperature)	T_{012}	Nm	0.38	0.31	0.22	0.18	0.16	0.16	0.15	0.12	0.12	0.11		
		in.lb	3.4	2.7	1.9	1.6	1.4	1.4	1.3	1.1	1.1	0.97		
Max. backlash	j_l	arcmin	≤ 8		≤ 10									
Torsional rigidity ^{b)}	C_{i21}	Nm/arcmin	12	12	12	12	12	12	12	10	12	12		
		in.lb/arcmin	106	106	106	106	106	106	106	89	106	106		
Max. axial force ^{c)}	F_{2AMax}	N	1900		1900									
		lb _f	428		428									
Max. lateral force ^{c)}	F_{2QMMax}	N	2800		2800									
		lb _f	630		630									
Max. tilting moment	M_{2KMMax}	Nm	137		137									
		in.lb	1213		1213									
Efficiency at full load	η	%	97		95									
Service life	L_n	h	> 20000		> 20000									
Weight (incl. standard adapter plate)	m	kg	3.8		4.1									
		lb _m	8.4		9.1									
Operating noise (at reference ratio and reference speed – ratio-specific values available in cymex®)	L_{PA}	dB(A)	≤ 61		≤ 59									
		°C	+90		+90									
Max. permitted housing temperature		°F	+194		+194									
		°C	-15 to +40		-15 to +40									
Ambient temperature		°F	+5 to +104		+5 to +104									
			Lubricated for life											
Direction of rotation			In- and output same direction											
Protection class			IP 64											
Elastomer coupling (recommended product type – validate sizing with cymex®)			ELC-0060BA022.000-X											
Bore diameter of coupling on the application side		mm	X = 012.000 - 032.000											
Mass moment of inertia (relates to the drive) Clamping hub diameter [mm]	A	9	J_1	kgcm ²	-	-	0.26	0.22	0.21	0.21	0.2	0.19	0.19	0.19
				10 ⁻³ in.lb.s ²	-	-	0.23	0.19	0.19	0.19	0.18	0.17	0.17	0.17
	B	11	J_1	kgcm ²	-	-	0.28	0.24	0.23	0.23	0.22	0.21	0.21	
				10 ⁻³ in.lb.s ²	-	-	0.25	0.21	0.2	0.2	0.19	0.19	0.19	
	C	14	J_1	kgcm ²	0.57	0.46	0.35	0.31	0.3	0.3	0.3	0.29	0.28	
				10 ⁻³ in.lb.s ²	0.5	0.41	0.31	0.27	0.27	0.27	0.27	0.26	0.25	
	D	16	J_1	kgcm ²	0.71	0.61	0.48	0.44	0.43	0.43	0.42	0.41	0.41	
				10 ⁻³ in.lb.s ²	0.63	0.54	0.42	0.39	0.38	0.38	0.37	0.36	0.36	
	E	19	J_1	kgcm ²	0.8	0.7	0.56	0.52	0.51	0.51	0.51	0.5	0.5	
				10 ⁻³ in.lb.s ²	0.71	0.62	0.5	0.46	0.45	0.45	0.45	0.44	0.44	
	G	24	J_1	kgcm ²	1.8	1.7	-	-	-	-	-	-	-	
				10 ⁻³ in.lb.s ²	1.6	1.5	-	-	-	-	-	-	-	
	H	28	J_1	kgcm ²	1.5	1.4	-	-	-	-	-	-	-	
				10 ⁻³ in.lb.s ²	1.3	1.2	-	-	-	-	-	-	-	

Please use our sizing software cymex® for a detailed sizing – www.wittenstein-cymex.com

^{a)} Valid for torque transmission only

^{b)} Valid for standard clamping hub diameter

^{c)} Refers to center of the output shaft or flange

^{d)} Please reduce input speed at higher ambient temperatures

^{e)} Valid for: Smooth shaft

1-stage

up to 19⁴⁾ (E)⁵⁾
clamping hub diameter

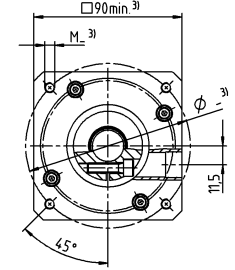
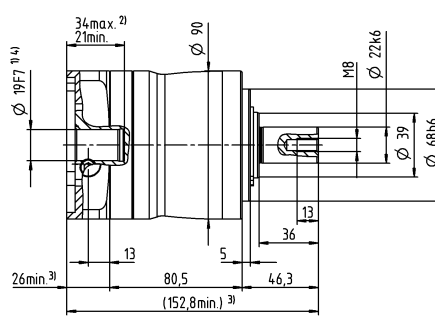
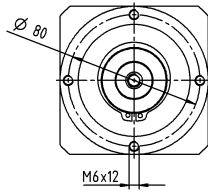

up to 28⁴⁾ (H)
clamping hub diameter

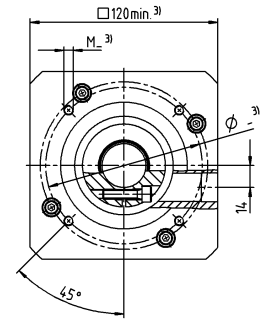
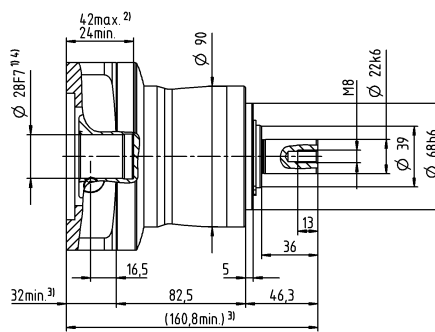
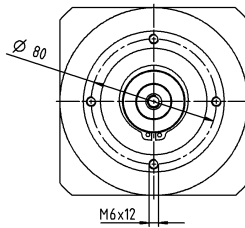

2-stage

up to 14⁴⁾ (C)⁵⁾
clamping hub diameter

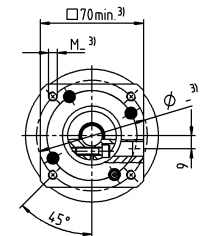
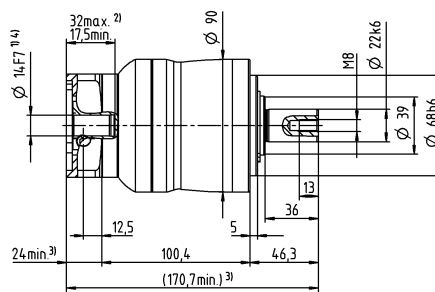
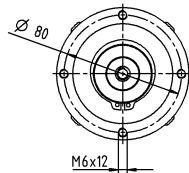

up to 19⁴⁾ (E)
clamping hub diameter

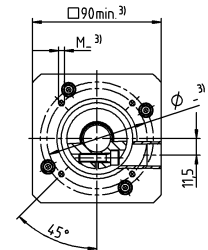
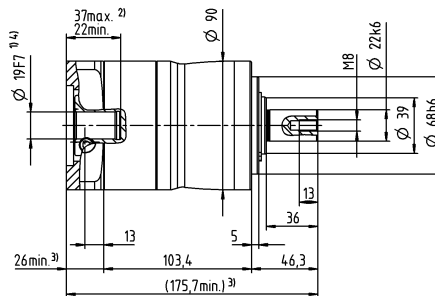
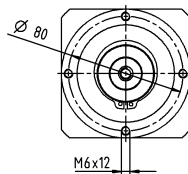

Motor shaft diameter [mm]

Other output variants

Shaft with key

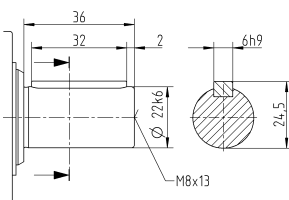

Non-tolerated dimensions are nominal dimensions

¹⁾ Check motor shaft fit

²⁾ Min. / Max. permissible motor shaft length

Longer motor shafts are possible, please contact alpha

³⁾ The dimensions depend on the motor

⁴⁾ Smaller motor shaft diameter is compensated by a bushing with a minimum wall thickness of 1 mm

⁵⁾ Standard clamping hub diameter

NP 035 MA 1-/2-stage

			1-stage		2-stage									
Ratio	i		3	4	9	12	15	16	20	28	30	40		
Max. torque ^{a) b) e)}	T_{2a}	Nm	480	480	480	480	480	480	480	480	432	480		
		in.lb	4248	4248	4248	4248	4248	4248	4248	4248	4248	3824	4248	
Max. acceleration torque ^{e)} (max. 1000 cycles per hour)	T_{2B}	Nm	305	305	305	305	300	305	305	305	270	305		
		in.lb	2699	2699	2699	2699	2655	2699	2699	2699	2390	2699		
Emergency stop torque ^{a) b) e)} (permitted 1000 times during the service life of the gearbox)	T_{2Not}	Nm	500	500	500	500	500	500	500	500	500	500		
		in.lb	4425	4425	4425	4425	4425	4425	4425	4425	4425	4425		
Permitted average input speed ^{d)} (at T_{2N} and 20 °C ambient temperature)	n_{1N}	rpm	2300	2500	3100	3300	3400	3300	3400	3600	3900	3900		
Max. input speed	n_{1Max}	rpm	6000	6000	7000	7000	7000	7000	7000	7000	7000	7000		
Mean no load running torque ^{b)} (at $n_i=3000$ rpm and 20 °C gearbox temperature)	T_{012}	Nm	1	0.85	0.45	0.36	0.3	0.32	0.27	0.22	0.19	0.18		
		in.lb	8.9	7.5	4	3.2	2.7	2.8	2.4	1.9	1.7	1.6		
Max. backlash	j_l	arcmin	≤ 8		≤ 10									
Torsional rigidity ^{b)}	C_{i21}	Nm/arcmin	30	30	30	30	30	30	30	30	30	30		
		in.lb/arcmin	266	266	266	266	266	266	266	266	266	266		
Max. axial force ^{c)}	F_{2AMax}	N	4000		4000									
		lb _f	900		900									
Max. lateral force ^{c)}	F_{2QMMax}	N	5000		5000									
		lb _f	1125		1125									
Max. tilting moment	M_{2KMMax}	Nm	345		345									
		in.lb	3054		3054									
Efficiency at full load	η	%	97		95									
Service life	L_n	h	> 20000		> 20000									
Weight (incl. standard adapter plate)	m	kg	9.4		9.8									
		lb _m	21		22									
Operating noise (at reference ratio and reference speed – ratio-specific values available in cymex®)	L_{PA}	dB(A)	≤ 65		≤ 61									
			+90		+90									
Max. permitted housing temperature		°C	+90		+90									
		°F	+194		+194									
Ambient temperature		°C	-15 to +40		-15 to +40									
		°F	+5 to +104		+5 to +104									
Lubrication			Lubricated for life											
Direction of rotation			In- and output same direction											
Protection class			IP 64											
Elastomer coupling (recommended product type – validate sizing with cymex®)			ELC-0150BA032.000-X											
Bore diameter of coupling on the application side		mm	X = 019.000 - 036.000											
Mass moment of inertia (relates to the drive) Clamping hub diameter [mm]	C	14	J_1	kgcm ²	-	-	0.61	0.6	0.6	0.43	0.42	0.37	0.52	0.36
				10 ⁻³ in.lb.s ²	-	-	0.54	0.53	0.53	0.38	0.37	0.33	0.46	0.32
	D	16	J_1	kgcm ²	-	-	0.76	0.75	0.75	0.58	0.57	0.5	0.67	0.51
				10 ⁻³ in.lb.s ²	-	-	0.67	0.66	0.66	0.51	0.5	0.44	0.59	0.45
	E	19	J_1	kgcm ²	2.6	1.7	0.85	0.83	0.83	0.67	0.66	0.6	0.75	0.6
				10 ⁻³ in.lb.s ²	2.3	1.5	0.75	0.73	0.73	0.59	0.58	0.53	0.66	0.53
	G	24	J_1	kgcm ²	3.4	2.5	1.9	1.9	1.9	1.7	1.7	1.6	1.8	1.6
				10 ⁻³ in.lb.s ²	3	2.2	1.7	1.7	1.7	1.5	1.5	1.4	1.6	1.4
	H	28	J_1	kgcm ²	3.1	2.2	1.6	1.6	1.6	1.4	1.4	1.3	0.5	1.3
				10 ⁻³ in.lb.s ²	2.7	1.9	1.4	1.4	1.4	1.2	1.2	1.2	0.44	1.2
	I	32	J_1	kgcm ²	7.2	6.3	-	-	-	-	-	-	-	-
				10 ⁻³ in.lb.s ²	6.4	5.6	-	-	-	-	-	-	-	-
K	38	J_1	kgcm ²	8.3	7.4	-	-	-	-	-	-	-	-	
			10 ⁻³ in.lb.s ²	7.3	6.5	-	-	-	-	-	-	-	-	

Please use our sizing software cymex® for a detailed sizing – www.wittenstein-cymex.com

^{a)} Valid for torque transmission only

^{b)} Valid for standard clamping hub diameter

^{c)} Refers to center of the output shaft or flange

^{d)} Please reduce input speed at higher ambient temperatures

^{e)} Valid for: Smooth shaft

1-stage

up to 24/28⁴⁾
(G⁵⁾/H)
clamping hub diameter

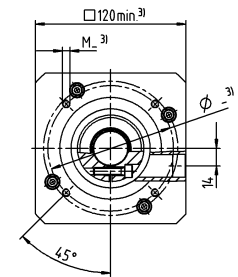
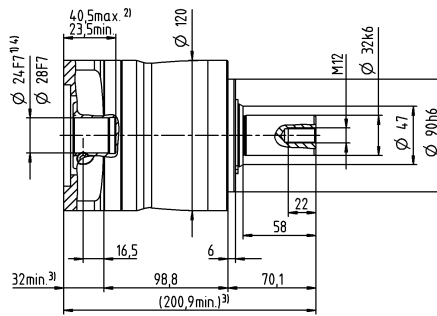
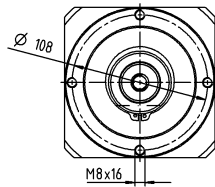

up to 38⁴⁾ (K)
clamping hub diameter

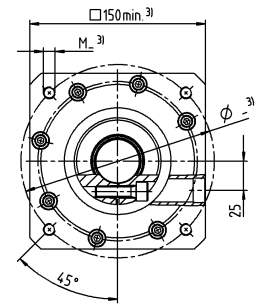
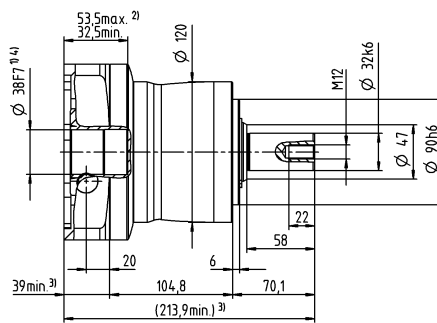
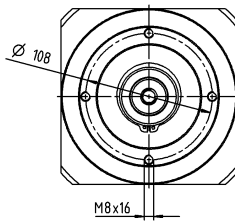

2-stage

up to 19⁴⁾ (E)⁵⁾
clamping hub diameter

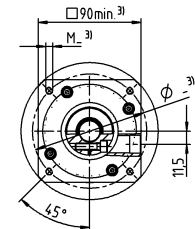
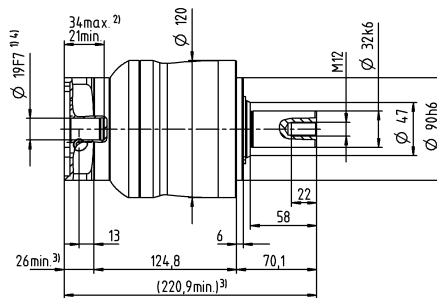
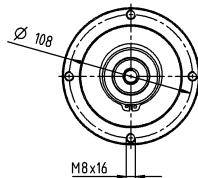

up to 28⁴⁾ (H)
clamping hub diameter

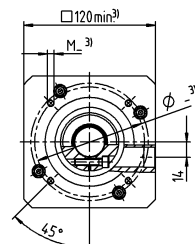
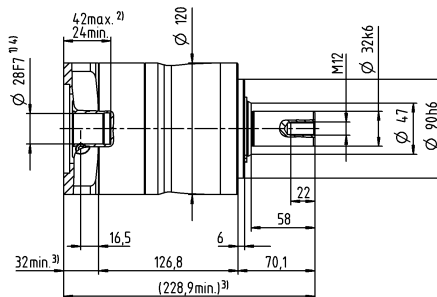
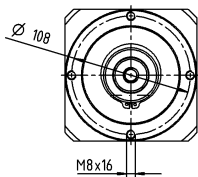

Motor shaft diameter [mm]

Other output variants

Shaft with key

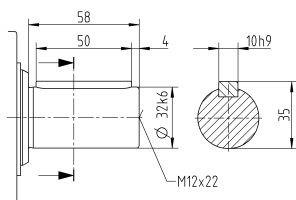

Non-tolerated dimensions are nominal dimensions

¹⁾ Check motor shaft fit

²⁾ Min. / Max. permissible motor shaft length

Longer motor shafts are possible, please contact alpha

³⁾ The dimensions depend on the motor

⁴⁾ Smaller motor shaft diameter is compensated

by a bushing with a minimum wall thickness of 1 mm

⁵⁾ Standard clamping hub diameter

NPL 015 MF 1-stage

			1-stage							
Ratio	i		3	4	5	7	8	10		
Max. torque ^{a) b) e)}	T_{2a}	Nm	51	56	64	64	56	56		
		in.lb	451	496	566	566	496	496		
Max. acceleration torque ^{e)} (max. 1000 cycles per hour)	T_{2B}	Nm	32	35	40	40	35	35		
		in.lb	283	310	354	354	310	310		
Emergency stop torque ^{a) b) e)} (permitted 1000 times during the service life of the gearbox)	T_{2Not}	Nm	80	80	80	80	80	80		
		in.lb	708	708	708	708	708	708		
Permitted average input speed ^{d)} (at T_{2N} and 20 °C ambient temperature)	n_{1N}	rpm	2900	3100	3300	3600	3600	3800		
Max. input speed	n_{1Max}	rpm	8000	8000	8000	8000	8000	8000		
Mean no load running torque ^{b)} (at $n_1=3000$ rpm and 20 °C gearbox temperature)	T_{012}	Nm	0.92	0.74	0.62	0.51	0.47	0.41		
		in.lb	8.1	6.5	5.5	4.5	4.2	3.6		
Max. backlash	j_l	arcmin	≤ 8							
Torsional rigidity ^{b)}	C_{i21}	Nm/arcmin	3.3	3.3	3.3	3.3	2.8	2.8		
		in.lb/arcmin	29	29	29	29	25	25		
Max. axial force ^{c)}	F_{2AMax}	N	2400							
		lb _f	540							
Max. lateral force ^{c)}	F_{2QMMax}	N	2800							
		lb _f	630							
Max. tilting moment	M_{2KMMax}	Nm	152							
		in.lb	1345							
Efficiency at full load	η	%	97							
Service life	L_n	h	> 20000							
Weight (incl. standard adapter plate)	m	kg	1.9							
		lb _m	4.2							
Operating noise (at reference ratio and reference speed – ratio-specific values available in cymex [®])	L_{PA}	dB(A)	≤ 59							
Max. permitted housing temperature		°C	+90							
		°F	+194							
Ambient temperature		°C	-15 to +40							
		°F	+5 to +104							
Lubrication			Lubricated for life							
Direction of rotation			In- and output same direction							
Protection class			IP 65							
Elastomer coupling (recommended product type – validate sizing with cymex [®])			ELC-0060BA016.000-X							
Bore diameter of coupling on the application side		mm	X = 012.000 - 032.000							
Mass moment of inertia (relates to the drive) Clamping hub diameter [mm]	A	9	J_1	kgcm ²	0.25	0.19	0.17	0.14	0.14	0.13
				10 ⁻³ in.lb.s ²	0.22	0.17	0.15	0.12	0.12	0.12
	B	11	J_1	kgcm ²	0.26	0.21	0.18	0.16	0.16	0.15
				10 ⁻³ in.lb.s ²	0.23	0.19	0.16	0.14	0.14	0.13
	C	14	J_1	kgcm ²	0.34	0.28	0.26	0.24	0.23	0.23
				10 ⁻³ in.lb.s ²	0.3	0.25	0.23	0.21	0.2	0.2
	D	16	J_1	kgcm ²	0.47	0.41	0.39	0.36	0.36	0.35
				10 ⁻³ in.lb.s ²	0.42	0.36	0.35	0.32	0.32	0.31
	E	19	J_1	kgcm ²	0.55	0.49	0.47	0.45	0.44	0.44
				10 ⁻³ in.lb.s ²	0.49	0.43	0.42	0.4	0.39	0.39

Please use our sizing software cymex[®] for a detailed sizing – www.wittenstein-cymex.com

^{a)} Valid for torque transmission only

^{b)} Valid for standard clamping hub diameter

^{c)} Refers to center of the output shaft or flange

^{d)} Please reduce input speed at higher ambient temperatures

^{e)} Valid for: Smooth shaft

1-stage

Motor shaft diameter [mm]

up to 14⁴⁾ (C)⁵⁾
clamping hub diameter

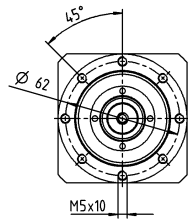

up to 19⁴⁾ (E)
clamping hub diameter

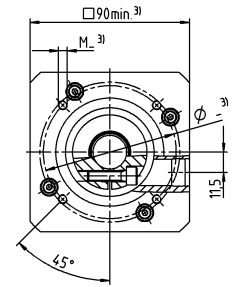
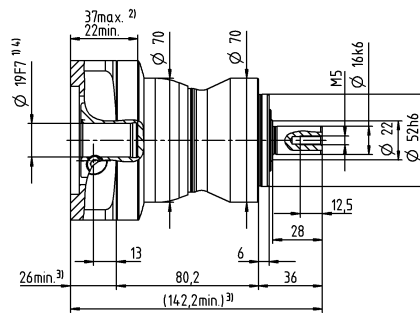
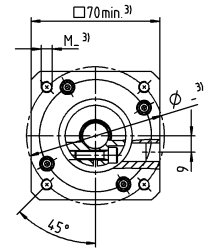
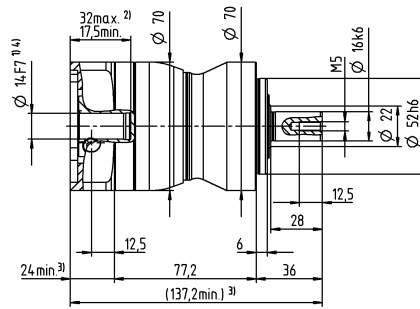
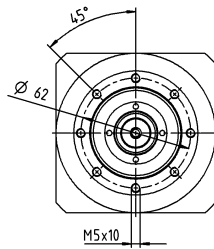

Planetary Gearboxes
Value Line

Other output variants

Shaft with key

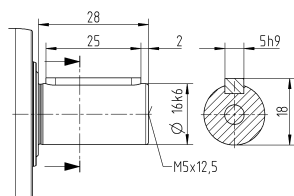

Splined shaft (DIN 5480)

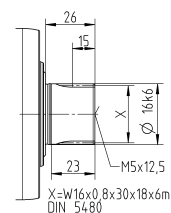

X=W16x0,8x30x18x6m
DIN 5480

Non-tolerated dimensions are nominal dimensions

¹⁾ Check motor shaft fit

²⁾ Min. / Max. permissible motor shaft length

Longer motor shafts are possible, please contact alpha

³⁾ The dimensions depend on the motor

⁴⁾ Smaller motor shaft diameter is compensated by a bushing with a minimum wall thickness of 1 mm

⁵⁾ Standard clamping hub diameter

NPL 015 MF 2-stage

			2-stage														
Ratio	i		12	15	16	20	25	28	30	32	35	40	50	64	70	100	
Max. torque ^{a) b) e)}	T_{2a}	Nm	51	51	56	56	64	56	51	56	64	56	64	56	64	56	
		in.lb	451	451	496	496	566	496	451	496	566	496	566	496	566	496	566
Max. acceleration torque ^{e)} (max. 1000 cycles per hour)	T_{2B}	Nm	32	32	35	35	40	35	32	35	40	35	40	35	40	35	
		in.lb	283	283	310	310	354	310	283	310	354	310	354	310	354	310	
Emergency stop torque ^{a) b) e)} (permitted 1000 times during the service life of the gearbox)	T_{2Not}	Nm	80	80	80	80	80	80	80	80	80	80	80	80	80	80	
		in.lb	708	708	708	708	708	708	708	708	708	708	708	708	708	708	
Permitted average input speed ^{d)} (at T_{2a} and 20 °C ambient temperature)	n_{1N}	rpm	3800	4000	3800	4000	4000	4300	4600	4400	4300	4600	4600	4400	4600	4600	
Max. input speed	n_{1Max}	rpm	10000	10000	10000	10000	10000	10000	10000	10000	10000	10000	10000	10000	10000	10000	
Mean no load running torque ^{b)} (at $n_1=3000$ rpm and 20 °C gearbox temperature)	T_{012}	Nm	0.34	0.29	0.29	0.25	0.23	0.21	0.21	0.2	0.2	0.19	0.17	0.17	0.16	0.15	
		in.lb	3	2.6	2.6	2.2	2	1.9	1.9	1.8	1.8	1.7	1.5	1.5	1.4	1.3	
Max. backlash	j_l	arcmin	≤ 10														
Torsional rigidity ^{b)}	C_{121}	Nm/arcmin	3.3	3.3	3.3	3.3	3.3	3.3	3.3	3.3	3.3	3.3	3.3	2.8	3.3	2.8	
		in.lb/arcmin	29	29	29	29	29	29	29	29	29	29	29	29	25	29	25
Max. axial force ^{c)}	F_{2AMax}	N	2400														
		lb _f	540														
Max. lateral force ^{c)}	F_{2QMMax}	N	2800														
		lb _f	630														
Max. tilting moment	M_{2KMMax}	Nm	152														
		in.lb	1345														
Efficiency at full load	η	%	95														
Service life	L_n	h	> 20000														
Weight (incl. standard adapter plate)	m	kg	2														
		lb _m	4.4														
Operating noise (at reference ratio and reference speed – ratio-specific values available in cymex [®])	L_{PA}	dB(A)	≤ 58														
Max. permitted housing temperature		°C	+90														
		°F	+194														
Ambient temperature		°C	-15 to +40														
		°F	+5 to +104														
Lubrication			Lubricated for life														
Direction of rotation			In- and output same direction														
Protection class			IP 65														
Elastomer coupling (recommended product type – validate sizing with cymex [®])			ELC-0060BA016.000-X														
Bore diameter of coupling on the application side		mm	X = 012.000 - 032.000														
Mass moment of inertia (relates to the drive) Clamping hub diameter [mm]	Z	8	J_1	kgcm ²	0.04	0.04	0.03	0.03	0.03	0.03	0.03	0.03	0.03	0.02	0.02	0.02	0.02
				10 ⁻³ in.lb.s ²	0.04	0.04	0.03	0.03	0.03	0.03	0.03	0.03	0.03	0.03	0.02	0.02	0.02
	A	9	J_1	kgcm ²	0.04	0.04	0.03	0.03	0.03	0.03	0.03	0.03	0.03	0.02	0.02	0.02	0.02
				10 ⁻³ in.lb.s ²	0.04	0.04	0.03	0.03	0.03	0.03	0.03	0.03	0.03	0.03	0.02	0.02	0.02
	B	11	J_1	kgcm ²	0.06	0.06	0.05	0.05	0.05	0.05	0.05	0.04	0.05	0.04	0.04	0.04	
				10 ⁻³ in.lb.s ²	0.05	0.05	0.04	0.04	0.04	0.04	0.04	0.04	0.04	0.04	0.04	0.04	0.04
	C	14	J_1	kgcm ²	0.14	0.14	0.14	0.13	0.13	0.13	0.14	0.13	0.13	0.13	0.13	0.13	
				10 ⁻³ in.lb.s ²	0.12	0.12	0.12	0.12	0.12	0.12	0.12	0.12	0.12	0.12	0.12	0.12	0.12

Please use our sizing software cymex[®] for a detailed sizing – www.wittenstein-cymex.com

^{a)} Valid for torque transmission only

^{b)} Valid for standard clamping hub diameter

^{c)} Refers to center of the output shaft or flange

^{d)} Please reduce input speed at higher ambient temperatures

^{e)} Valid for: Smooth shaft

2-stage

Motor shaft diameter [mm]

up to 11⁴⁾ (B)⁵⁾
clamping hub diameter

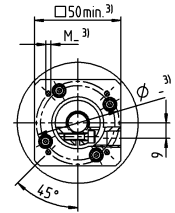
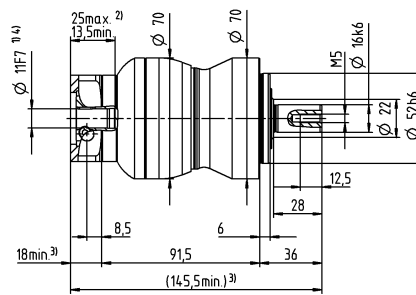
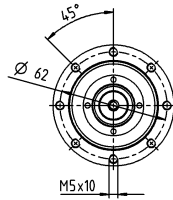

up to 14⁴⁾ (C)
clamping hub diameter

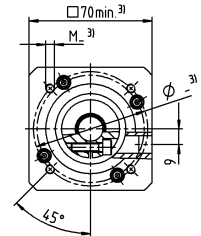
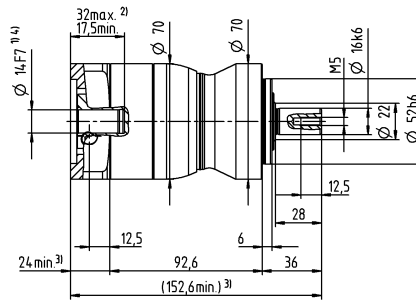
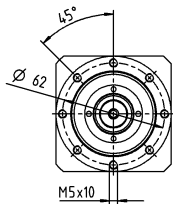

Planetary Gearboxes
Value Line

Other output variants

Shaft with key

Splined shaft (DIN 5480)

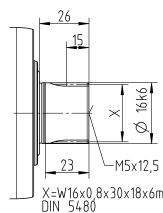
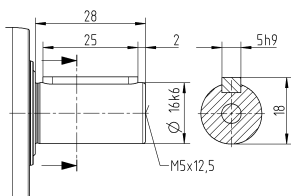

Non-tolerated dimensions are nominal dimensions

¹⁾ Check motor shaft fit

²⁾ Min. / Max. permissible motor shaft length

Longer motor shafts are possible, please contact alpha

³⁾ The dimensions depend on the motor

⁴⁾ Smaller motor shaft diameter is compensated by a bushing with a minimum wall thickness of 1 mm

⁵⁾ Standard clamping hub diameter

NPL 025 MF 1-stage

			1-stage							
Ratio	i		3	4	5	7	8	10		
Max. torque ^{a) b) e)}	T_{2a}	Nm	128	152	160	160	144	144		
		in.lb	1133	1345	1416	1416	1275	1275		
Max. acceleration torque ^{e)} (max. 1000 cycles per hour)	T_{2B}	Nm	80	95	100	100	90	90		
		in.lb	708	841	885	885	797	797		
Emergency stop torque ^{a) b) e)} (permitted 1000 times during the service life of the gearbox)	T_{2Not}	Nm	190	190	190	190	190	190		
		in.lb	1682	1682	1682	1682	1682	1682		
Permitted average input speed ^{d)} (at T_{2a} and 20 °C ambient temperature)	n_{1N}	rpm	2700	2900	3000	3200	3300	3500		
Max. input speed	n_{1Max}	rpm	7000	7000	7000	7000	7000	7000		
Mean no load running torque ^{b)} (at $n_1=3000$ rpm and 20 °C gearbox temperature)	T_{012}	Nm	1.8	1.5	1.3	1.1	1	0.94		
		in.lb	16	13	12	9.7	8.9	8.3		
Max. backlash	j_l	arcmin	≤ 8							
Torsional rigidity ^{b)}	C_{i21}	Nm/arcmin	9.5	9.5	9.5	9.5	8.5	8.5		
		in.lb/arcmin	84	84	84	84	75	75		
Max. axial force ^{c)}	F_{2AMax}	N	3350							
		lb _f	754							
Max. lateral force ^{c)}	F_{2QMMax}	N	4200							
		lb _f	945							
Max. tilting moment	M_{2KMMax}	Nm	236							
		in.lb	2089							
Efficiency at full load	η	%	97							
Service life	L_n	h	> 20000							
Weight (incl. standard adapter plate)	m	kg	3.9							
		lb _m	8.6							
Operating noise (at reference ratio and reference speed – ratio-specific values available in cymex [®])	L_{PA}	dB(A)	≤ 61							
Max. permitted housing temperature		°C	+90							
		°F	+194							
Ambient temperature		°C	-15 to +40							
		°F	+5 to +104							
Lubrication			Lubricated for life							
Direction of rotation			In- and output same direction							
Protection class			IP 65							
Elastomer coupling (recommended product type – validate sizing with cymex [®])			ELC-0060BA022.000-X							
Bore diameter of coupling on the application side		mm	X = 012.000 - 032.000							
Mass moment of inertia (relates to the drive) Clamping hub diameter [mm]	C	14	J_1	kgcm ²	0.58	0.47	0.38	0.3	0.28	0.26
				10 ⁻³ in.lb.s ²	0.51	0.42	0.34	0.27	0.25	0.23
	D	16	J_1	kgcm ²	0.73	0.62	0.53	0.43	0.42	0.4
				10 ⁻³ in.lb.s ²	0.65	0.55	0.47	0.38	0.37	0.35
	E	19	J_1	kgcm ²	0.81	0.71	0.61	0.53	0.51	0.49
				10 ⁻³ in.lb.s ²	0.72	0.63	0.54	0.47	0.45	0.43
	G	24	J_1	kgcm ²	1.8	1.7	1.6	1.6	1.5	1.5
				10 ⁻³ in.lb.s ²	1.6	1.5	1.4	1.4	1.3	1.3
	H	28	J_1	kgcm ²	1.6	1.4	1.4	1.3	1.3	1.2
				10 ⁻³ in.lb.s ²	1.4	1.2	1.2	1.2	1.2	1.1

Please use our sizing software cymex[®] for a detailed sizing – www.wittenstein-cymex.com

^{a)} Valid for torque transmission only

^{b)} Valid for standard clamping hub diameter

^{c)} Refers to center of the output shaft or flange

^{d)} Please reduce input speed at higher ambient temperatures

^{e)} Valid for: Smooth shaft

1-stage

up to 19⁴⁾ (E)⁵⁾
clamping hub diameter

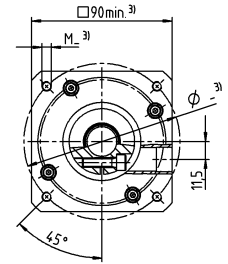
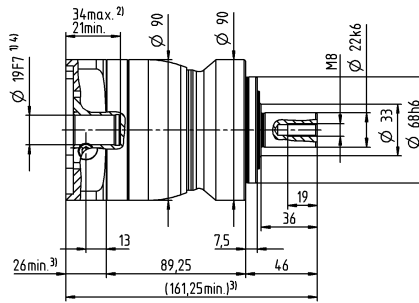
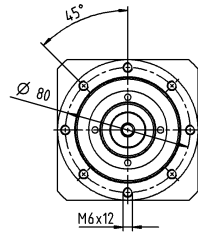

Motor shaft diameter [mm]

up to 28⁴⁾ (H)
clamping hub diameter

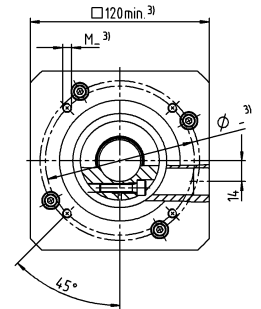
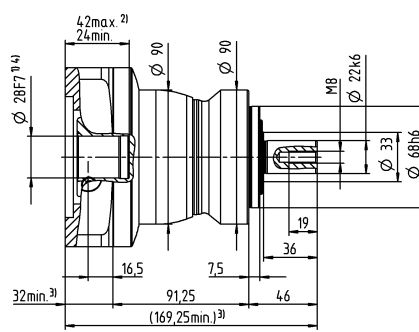
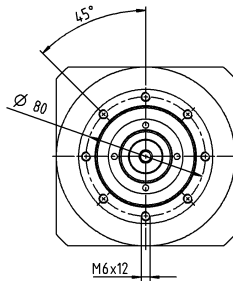

Planetary Gearboxes
Value Line

Other output variants

Shaft with key

Splined shaft (DIN 5480)

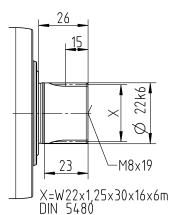
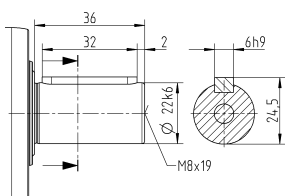

Non-tolerated dimensions are nominal dimensions

¹⁾ Check motor shaft fit

²⁾ Min. / Max. permissible motor shaft length

Longer motor shafts are possible, please contact alpha

³⁾ The dimensions depend on the motor

⁴⁾ Smaller motor shaft diameter is compensated

by a bushing with a minimum wall thickness of 1 mm

⁵⁾ Standard clamping hub diameter

NPL 025 MF 2-stage

			2-stage															
Ratio	i		9	12	15	16	20	25	28	30	32	35	40	50	64	70	100	
Max. torque ^{a) b) e)}	T_{2a}	Nm	128	128	128	152	152	160	152	128	144	160	152	160	144	160	144	
		in.lb	1133	1133	1133	1345	1345	1416	1345	1133	1275	1416	1345	1416	1275	1416	1275	
Max. acceleration torque ^{e)} (max. 1000 cycles per hour)	T_{2B}	Nm	80	80	80	95	95	100	95	80	90	100	95	100	90	100	90	
		in.lb	708	708	708	841	841	885	841	708	797	885	841	885	797	885	797	
Emergency stop torque ^{a) b) e)} (permitted 1000 times during the service life of the gearbox)	T_{2Not}	Nm	190	190	190	190	190	190	190	190	190	190	190	190	190	190	190	
		in.lb	1682	1682	1682	1682	1682	1682	1682	1682	1682	1682	1682	1682	1682	1682	1682	
Permitted average input speed ^{d)} (at T_{2N} and 20 °C ambient temperature)	n_{1N}	rpm	2900	3500	3700	3500	3700	3700	4000	4300	4100	4000	4300	4300	4100	4300	4300	
Max. input speed	n_{1Max}	rpm	8000	8000	8000	8000	8000	8000	8000	8000	8000	8000	8000	8000	8000	8000	8000	
Mean no load running torque ^{b)} (at $n_1=3000$ rpm and 20 °C gearbox temperature)	T_{012}	Nm	0.67	0.55	0.47	0.46	0.4	0.36	0.34	0.33	0.32	0.31	0.29	0.27	0.25	0.25	0.23	
		in.lb	5.9	4.9	4.2	4.1	3.5	3.2	3	2.9	2.8	2.7	2.6	2.4	2.2	2.2	2	
Max. backlash	j_l	arcmin	≤ 10															
Torsional rigidity ^{b)}	C_{121}	Nm/arcmin	10	10	10	10	10	9.5	10	10	10	9.5	10	9.5	8.5	9.5	8.5	
		in.lb/arcmin	89	89	89	89	89	84	89	89	89	89	84	89	84	75	84	75
Max. axial force ^{c)}	F_{2AMax}	N	3350															
		lb _f	754															
Max. lateral force ^{c)}	F_{2QMMax}	N	4200															
		lb _f	945															
Max. tilting moment	M_{2KMMax}	Nm	236															
		in.lb	2089															
Efficiency at full load	η	%	95															
Service life	L_n	h	> 20000															
Weight (incl. standard adapter plate)	m	kg	4.2															
		lb _m	9.3															
Operating noise (at reference ratio and reference speed – ratio-specific values available in cymex [®])	L_{PA}	dB(A)	≤ 59															
Max. permitted housing temperature		°C	+90															
		°F	+194															
Ambient temperature		°C	-15 to +40															
		°F	+5 to +104															
Lubrication			Lubricated for life															
Direction of rotation			In- and output same direction															
Protection class			IP 65															
Elastomer coupling (recommended product type – validate sizing with cymex [®])			ELC-0060BA022.000-X															
Bore diameter of coupling on the application side		mm	X = 012.000 - 032.000															
Mass moment of inertia (relates to the drive) Clamping hub diameter [mm]	A	9	J_1	kgcm ²	0.26	0.22	0.21	0.21	0.2	0.2	0.19	0.19	0.19	0.19	0.19	0.19	0.19	0.19
				10 ⁻³ in.lb.s ²	0.23	0.19	0.19	0.19	0.18	0.18	0.17	0.17	0.17	0.17	0.17	0.17	0.17	0.17
	B	11	J_1	kgcm ²	0.28	0.24	0.23	0.23	0.22	0.22	0.21	0.21	0.21	0.21	0.21	0.21	0.21	0.21
				10 ⁻³ in.lb.s ²	0.25	0.21	0.2	0.2	0.19	0.19	0.19	0.19	0.19	0.19	0.19	0.19	0.19	0.19
	C	14	J_1	kgcm ²	0.35	0.31	0.3	0.3	0.3	0.29	0.29	0.28	0.28	0.28	0.28	0.28	0.28	0.28
				10 ⁻³ in.lb.s ²	0.31	0.27	0.27	0.27	0.27	0.26	0.26	0.25	0.25	0.25	0.25	0.25	0.25	0.25
	D	16	J_1	kgcm ²	0.48	0.44	0.43	0.43	0.42	0.42	0.41	0.41	0.41	0.41	0.41	0.41	0.41	0.41
				10 ⁻³ in.lb.s ²	0.42	0.39	0.38	0.38	0.37	0.37	0.36	0.36	0.36	0.36	0.36	0.36	0.36	0.36
	E	19	J_1	kgcm ²	0.56	0.52	0.51	0.52	0.51	0.5	0.5	0.5	0.5	0.5	0.49	0.49	0.49	0.49
				10 ⁻³ in.lb.s ²	0.5	0.46	0.45	0.46	0.45	0.44	0.44	0.44	0.44	0.44	0.43	0.43	0.43	0.43

Please use our sizing software cymex[®] for a detailed sizing – www.wittenstein-cymex.com

^{a)} Valid for torque transmission only

^{b)} Valid for standard clamping hub diameter

^{c)} Refers to center of the output shaft or flange

^{d)} Please reduce input speed at higher ambient temperatures

^{e)} Valid for: Smooth shaft

2-stage

Motor shaft diameter [mm]

up to 14⁴⁾ (C)⁵⁾
clamping hub diameter

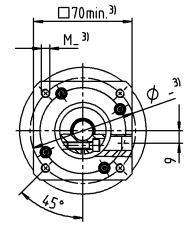
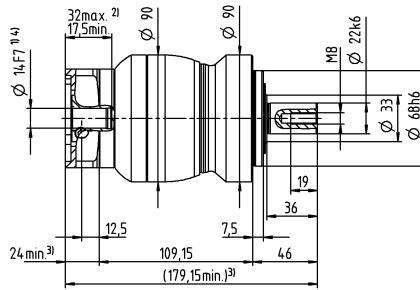
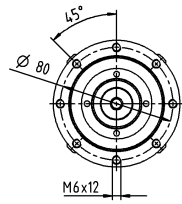

up to 19⁴⁾ (E)
clamping hub diameter

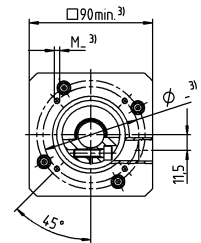
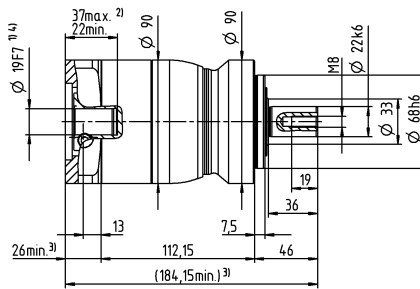
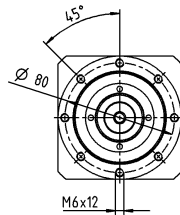

Planetary Gearboxes
Value Line

Other output variants

Shaft with key

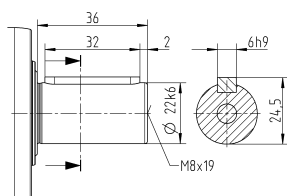

Splined shaft (DIN 5480)

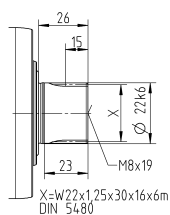

Non-tolerated dimensions are nominal dimensions

¹⁾ Check motor shaft fit

²⁾ Min. / Max. permissible motor shaft length

Longer motor shafts are possible, please contact alpha

³⁾ The dimensions depend on the motor

⁴⁾ Smaller motor shaft diameter is compensated by a bushing with a minimum wall thickness of 1 mm

⁵⁾ Standard clamping hub diameter

NPL 035 MF 1-stage

			1-stage							
Ratio	i		3	4	5	7	8	10		
Max. torque ^{a) b) e)}	T_{2a}	Nm	320	408	400	400	352	352		
		in.lb	2832	3611	3540	3540	3115	3115		
Max. acceleration torque ^{e)} (max. 1000 cycles per hour)	T_{2B}	Nm	200	255	250	250	220	220		
		in.lb	1770	2257	2213	2213	1947	1947		
Emergency stop torque ^{a) b) e)} (permitted 1000 times during the service life of the gearbox)	T_{2Not}	Nm	500	500	500	500	500	500		
		in.lb	4425	4425	4425	4425	4425	4425		
Permitted average input speed ^{d)} (at T_{2a} and 20 °C ambient temperature)	n_{1N}	rpm	2000	2200	2300	2500	2600	2700		
Max. input speed	n_{1Max}	rpm	6000	6000	6000	6000	6000	6000		
Mean no load running torque ^{b)} (at $n_1=3000$ rpm and 20 °C gearbox temperature)	T_{012}	Nm	3.3	2.7	2.3	1.9	1.7	1.5		
		in.lb	29	24	20	17	15	13		
Max. backlash	j_l	arcmin	≤ 8							
Torsional rigidity ^{b)}	C_{t21}	Nm/arcmin	25	25	25	25	22	22		
		in.lb/arcmin	221	221	221	221	195	195		
Max. axial force ^{c)}	F_{2AMax}	N	5650							
		lb _f	1271							
Max. lateral force ^{c)}	F_{2QMMax}	N	6600							
		lb _f	1485							
Max. tilting moment	M_{2KMMax}	Nm	487							
		in.lb	4310							
Efficiency at full load	η	%	97							
Service life	L_n	h	> 20000							
Weight (incl. standard adapter plate)	m	kg	9.1							
		lb _m	20							
Operating noise (at reference ratio and reference speed – ratio-specific values available in cymex [®])	L_{PA}	dB(A)	≤ 65							
Max. permitted housing temperature		°C	+90							
		°F	+194							
Ambient temperature		°C	-15 to +40							
		°F	+5 to +104							
Lubrication			Lubricated for life							
Direction of rotation			In- and output same direction							
Protection class			IP 65							
Elastomer coupling (recommended product type – validate sizing with cymex [®])			ELC-0150BA032.000-X							
Bore diameter of coupling on the application side		mm	X = 019.000 - 036.000							
Mass moment of inertia (relates to the drive) Clamping hub diameter [mm]	E	19	J_1	kgcm ²	2.5	1.7	1.3	1	0.94	0.87
				10 ⁻³ in.lb.s ²	2.2	1.5	1.2	0.89	0.83	0.77
	G	24	J_1	kgcm ²	3.3	2.4	2.1	1.8	1.7	1.6
				10 ⁻³ in.lb.s ²	2.9	2.1	1.9	1.6	1.5	1.4
	H	28	J_1	kgcm ²	3	2.2	1.8	1.5	1.4	1.4
				10 ⁻³ in.lb.s ²	2.7	1.9	1.6	1.3	1.2	1.2
	I	32	J_1	kgcm ²	7.1	6.2	5.9	5.6	5.5	5.4
				10 ⁻³ in.lb.s ²	6.3	5.5	5.2	5	4.9	4.8
	K	38	J_1	kgcm ²	8.3	7.4	7.1	6.7	6.6	6.6
				10 ⁻³ in.lb.s ²	7.3	6.5	6.3	5.9	5.8	5.8

Please use our sizing software cymex[®] for a detailed sizing – www.wittenstein-cymex.com

^{a)} Valid for torque transmission only

^{b)} Valid for standard clamping hub diameter

^{c)} Refers to center of the output shaft or flange

^{d)} Please reduce input speed at higher ambient temperatures

^{e)} Valid for: Smooth shaft

1-stage

Motor shaft diameter [mm]

up to 24/28⁴⁾
(G⁵⁾/H)
clamping hub diameter

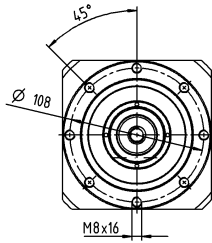

up to 38⁴⁾ (K)
clamping hub diameter

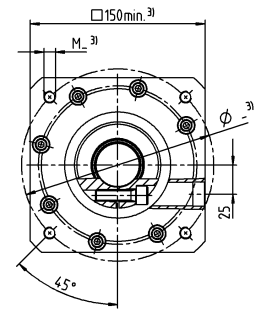
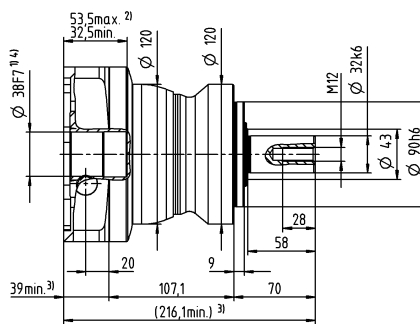
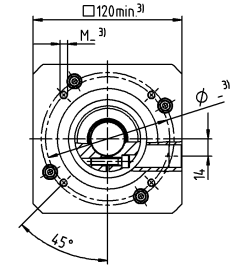
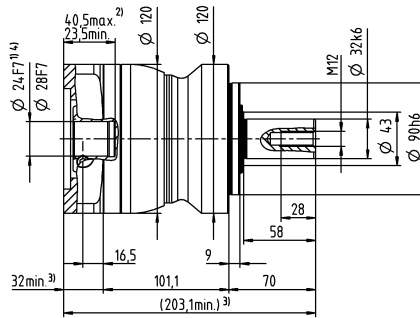
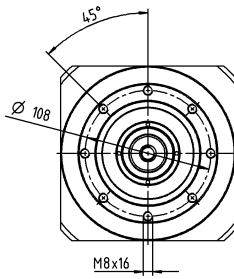

Other output variants

Shaft with key

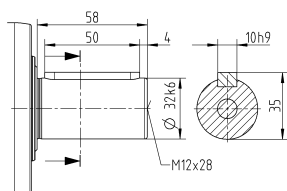

Splined shaft (DIN 5480)

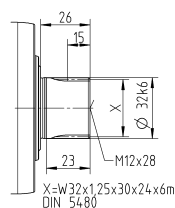

Non-tolerated dimensions are nominal dimensions

¹⁾ Check motor shaft fit

²⁾ Min. / Max. permissible motor shaft length

Longer motor shafts are possible, please contact alpha

³⁾ The dimensions depend on the motor

⁴⁾ Smaller motor shaft diameter is compensated by a bushing with a minimum wall thickness of 1 mm

⁵⁾ Standard clamping hub diameter

NPL 035 MF 2-stage

			2-stage																
Ratio	i		9	12	15	16	20	25	28	30	32	35	40	50	64	70	100		
Max. torque ^{a) b) e)}	T_{2a}	Nm	320	320	320	408	408	400	408	320	408	400	408	400	352	400	352		
		in.lb	2832	2832	2832	3611	3611	3540	3611	2832	3611	3540	3611	3540	3115	3540	3115		
Max. acceleration torque ^{e)} (max. 1000 cycles per hour)	T_{2B}	Nm	200	200	200	255	255	250	255	200	255	250	255	250	220	250	220		
		in.lb	1770	1770	1770	2257	2257	2213	2257	1770	2257	2213	2257	2213	1947	2213	1947		
Emergency stop torque ^{a) b) e)} (permitted 1000 times during the service life of the gearbox)	T_{2Not}	Nm	500	500	500	500	500	500	500	500	500	500	500	500	500	500	500		
		in.lb	4425	4425	4425	4425	4425	4425	4425	4425	4425	4425	4425	4425	4425	4425	4425		
Permitted average input speed ^{d)} (at T_{2a} and 20 °C ambient temperature)	n_{1N}	rpm	2700	3300	3400	3300	3400	3400	3600	3900	3700	3600	3900	3900	3700	3900	3900		
Max. input speed	n_{1Max}	rpm	7000	7000	7000	7000	7000	7000	7000	7000	7000	7000	7000	7000	7000	7000	7000		
Mean no load running torque ^{b)} (at $n_1=3000$ rpm and 20 °C gearbox temperature)	T_{012}	Nm	1.7	1.4	1.2	1.2	1.1	1	0.93	0.88	0.88	0.87	0.81	0.77	0.75	0.72	0.68		
		in.lb	15	12	11	11	9.7	8.9	8.2	7.8	7.8	7.7	7.2	6.8	6.6	6.4	6		
Max. backlash	j_l	arcmin	≤ 10																
Torsional rigidity ^{b)}	C_{121}	Nm/arcmin	25	25	25	25	25	25	25	25	25	25	25	25	22	25	22		
		in.lb/arcmin	221	221	221	221	221	221	221	221	221	221	221	221	195	221	195		
Max. axial force ^{c)}	F_{2AMax}	N	5650																
		lb _f	1271																
Max. lateral force ^{c)}	F_{2QMMax}	N	6600																
		lb _f	1485																
Max. tilting moment	M_{2KMMax}	Nm	487																
		in.lb	4310																
Efficiency at full load	η	%	95																
Service life	L_n	h	> 20000																
Weight (incl. standard adapter plate)	m	kg	9.5																
		lb _m	21																
Operating noise (at reference ratio and reference speed – ratio-specific values available in cymex®)	L_{PA}	dB(A)	≤ 61																
Max. permitted housing temperature		°C	+90																
		°F	+194																
Ambient temperature		°C	-15 to +40																
		°F	+5 to +104																
Lubrication			Lubricated for life																
Direction of rotation			In- and output same direction																
Protection class			IP 65																
Elastomer coupling (recommended product type – validate sizing with cymex®)			ELC-0150BA032.000-X																
Bore diameter of coupling on the application side		mm	X = 019.000 - 036.000																
Mass moment of inertia (relates to the drive) Clamping hub diameter [mm]	C	14	J_1	kgcm ²	0.6	0.59	0.6	0.43	0.42	0.36	0.37	0.52	0.38	0.32	0.36	0.31	0.26	0.27	0.24
				10 ⁻³ in.lb.s ²	0.53	0.52	0.53	0.38	0.37	0.32	0.33	0.46	0.34	0.28	0.32	0.27	0.23	0.24	0.21
	D	16	J_1	kgcm ²	0.75	0.74	0.74	0.58	0.57	0.5	0.5	0.67	0.52	0.45	0.51	0.46	0.4	0.41	0.39
				10 ⁻³ in.lb.s ²	0.66	0.65	0.65	0.51	0.5	0.44	0.44	0.59	0.46	0.4	0.45	0.41	0.35	0.36	0.35
	E	19	J_1	kgcm ²	0.84	0.83	0.83	0.66	0.65	0.59	0.6	0.75	0.61	0.55	0.6	0.54	0.49	0.5	0.48
				10 ⁻³ in.lb.s ²	0.74	0.73	0.73	0.58	0.58	0.52	0.53	0.66	0.54	0.49	0.53	0.48	0.43	0.44	0.42
	G	24	J_1	kgcm ²	1.9	1.9	1.9	1.7	1.7	1.6	1.6	1.8	1.6	1.6	1.6	1.6	1.5	1.5	1.5
				10 ⁻³ in.lb.s ²	1.7	1.6	1.7	1.5	1.5	1.4	1.5	1.6	1.5	1.4	1.4	1.4	1.4	1.3	1.4
	H	28	J_1	kgcm ²	1.6	1.6	1.6	1.4	1.4	1.3	1.3	1.5	1.4	1.3	1.3	1.3	1.2	1.2	1.2
				10 ⁻³ in.lb.s ²	1.4	1.4	1.4	1.2	1.2	1.2	1.2	1.3	1.2	1.1	1.2	1.1	1.1	1.1	1.1

Please use our sizing software cymex® for a detailed sizing – www.wittenstein-cymex.com

^{a)} Valid for torque transmission only

^{b)} Valid for standard clamping hub diameter

^{c)} Refers to center of the output shaft or flange

^{d)} Please reduce input speed at higher ambient temperatures

^{e)} Valid for: Smooth shaft

2-stage

Motor shaft diameter [mm]

up to 19⁴⁾ (E)⁵⁾
clamping hub diameter

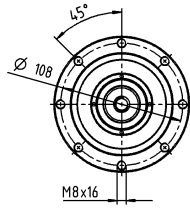

up to 28⁴⁾ (H)
clamping hub diameter

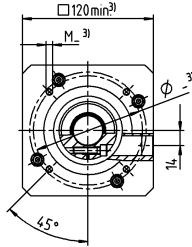
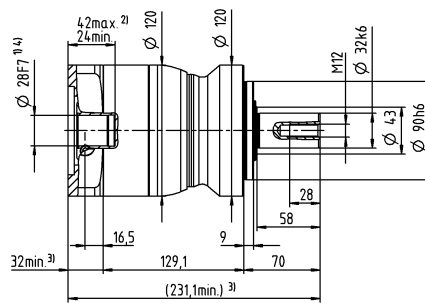
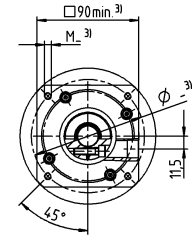
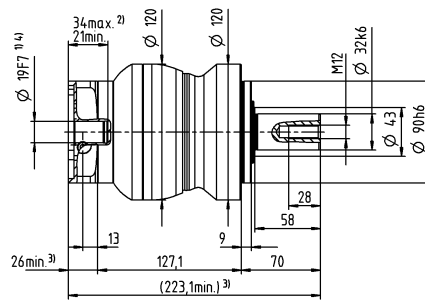
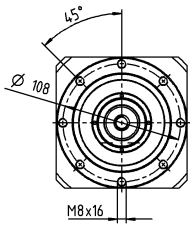

Other output variants

Shaft with key

Splined shaft (DIN 5480)

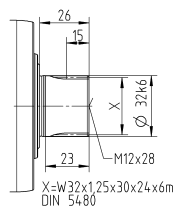
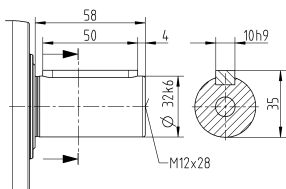

Non-tolerated dimensions are nominal dimensions

¹⁾ Check motor shaft fit

²⁾ Min. / Max. permissible motor shaft length

Longer motor shafts are possible, please contact alpha

³⁾ The dimensions depend on the motor

⁴⁾ Smaller motor shaft diameter is compensated

by a bushing with a minimum wall thickness of 1 mm

⁵⁾ Standard clamping hub diameter

NPL 045 MF 1-/2-stage

			1-stage			2-stage						
Ratio	i		5	8	10	25	32	50	64	100		
Max. torque ^{a) b) e)}	T_{2a}	Nm	800	640	640	700	640	700	640	640		
		in.lb	7081	5665	5665	6196	5665	6196	5665	5665		
Max. acceleration torque ^{e)} (max. 1000 cycles per hour)	T_{2B}	Nm	500	400	400	500	400	500	400	400		
		in.lb	4425	3540	3540	4425	3540	4425	3540	3540		
Emergency stop torque ^{a) b) e)} (permitted 1000 times during the service life of the gearbox)	T_{2Not}	Nm	1000	1000	1000	1000	1000	1000	1000	1000		
		in.lb	8851	8851	8851	8851	8851	8851	8851	8851		
Permitted average input speed ^{d)} (at T_{2N} and 20 °C ambient temperature)	n_{1N}	rpm	1800	1900	2000	2600	2500	3000	2900	3000		
Max. input speed	n_{1Max}	rpm	4000	4000	4000	6000	6000	6000	6000	6000		
Mean no load running torque ^{b)} (at $n_1=3000$ rpm and 20 °C gearbox temperature)	T_{012}	Nm	4.2	3	2.6	1.6	1.5	1.2	1.1	0.97		
		in.lb	37	27	23	14	13	11	9.7	8.6		
Max. backlash	j_l	arcmin	≤ 8			≤ 10						
Torsional rigidity ^{b)}	C_{i21}	Nm/arcmin	55	44	44	55	44	55	44	44		
		in.lb/arcmin	487	389	389	487	389	487	389	389		
Max. axial force ^{c)}	F_{2AMax}	N	9870			9870						
		lb _f	2221			2221						
Max. lateral force ^{c)}	F_{2QMax}	N	9900			9900						
		lb _f	2228			2228						
Max. tilting moment	M_{2KMMax}	Nm	952			952						
		in.lb	8426			8426						
Efficiency at full load	η	%	97			95						
Service life	L_n	h	> 20000			> 20000						
Weight (incl. standard adapter plate)	m	kg	20			20						
		lb _m	44			44						
Operating noise (at reference ratio and reference speed – ratio-specific values available in cymex [®])	L_{PA}	dB(A)	≤ 68			≤ 65						
Max. permitted housing temperature		°C	+90			+90						
		°F	+194			+194						
Ambient temperature		°C	-15 to +40			-15 to +40						
		°F	+5 to +104			+5 to +104						
Lubrication			Lubricated for life									
Direction of rotation			In- and output same direction									
Protection class			IP 65									
Elastomer coupling (recommended product type – validate sizing with cymex [®])			ELC-0300BA040.000-X									
Bore diameter of coupling on the application side		mm	X = 020.000 - 045.000									
Mass moment of inertia (relates to the drive) Clamping hub diameter [mm]	E	19	J_1	kgcm ²	-	-	-	1.2	1.1	1	0.88	0.82
				10 ⁻³ in.lb.s ²	-	-	-	1.1	0.97	0.89	0.78	0.73
	G	24	J_1	kgcm ²	-	-	-	2	1.9	1.8	1.7	1.6
				10 ⁻³ in.lb.s ²	-	-	-	1.8	1.7	1.6	1.5	1.4
	H	28	J_1	kgcm ²	-	-	-	1.7	1.6	1.5	1.4	1.3
				10 ⁻³ in.lb.s ²	-	-	-	1.5	1.4	1.3	1.2	1.2
	I	32	J_1	kgcm ²	-	-	-	5.8	5.7	5.6	5.4	5.4
				10 ⁻³ in.lb.s ²	-	-	-	5.1	5	5	4.8	4.8
	K	38	J_1	kgcm ²	8.7	7.3	7.2	7	6.9	6.8	6.6	6.5
				10 ⁻³ in.lb.s ²	7.7	6.5	6.4	6.2	6.1	6	5.8	5.8

Please use our sizing software cymex[®] for a detailed sizing – www.wittenstein-cymex.com

^{a)} Valid for torque transmission only

^{b)} Valid for standard clamping hub diameter

^{c)} Refers to center of the output shaft or flange

^{d)} Please reduce input speed at higher ambient temperatures

^{e)} Valid for: Smooth shaft

1-stage

up to 38⁴⁾ (K)⁵⁾
clamping hub
diameter

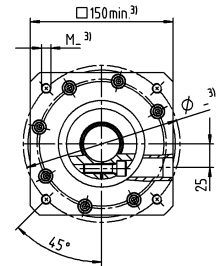
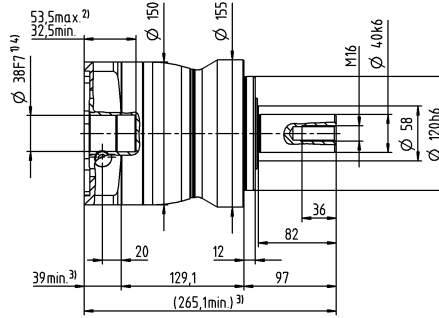
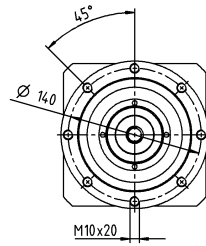

2-stage

up to 28⁴⁾ (H)⁵⁾
clamping hub
diameter

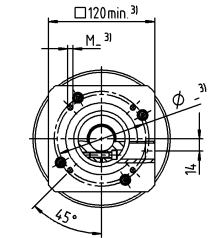
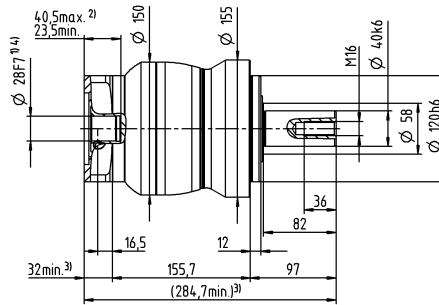
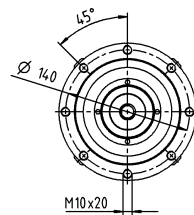

Motor shaft diameter [mm]

up to 38⁴⁾ (K)
clamping hub
diameter

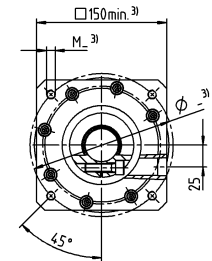
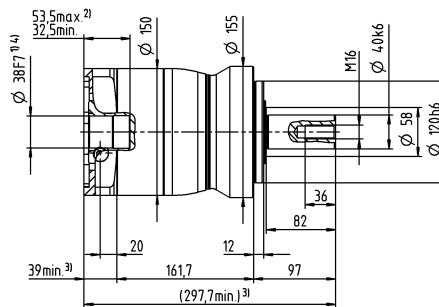
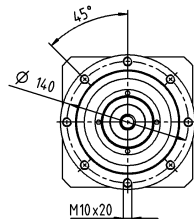

Planetary Gearboxes
Value Line

Other output variants

Shaft with key

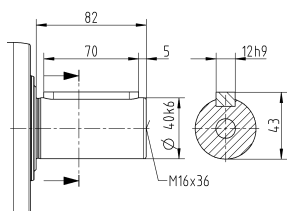

Splined shaft (DIN 5480)

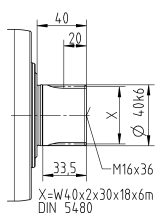

Non-tolerated dimensions are nominal dimensions

¹⁾ Check motor shaft fit

²⁾ Min. / Max. permissible motor shaft length

Longer motor shafts are possible, please contact alpha

³⁾ The dimensions depend on the motor

⁴⁾ Smaller motor shaft diameter is compensated

by a bushing with a minimum wall thickness of 1 mm

⁵⁾ Standard clamping hub diameter

NPL 015 MA 1-/2-stage

			1-stage		2-stage							
Ratio	i		3	4	12	15	16	20	28	30	40	
Max. torque ^{a) b) e)}	T_{2a}	Nm	80	67	62	67	67	67	67	62	67	
		in.lb	708	593	549	593	593	593	593	593	549	593
Max. acceleration torque ^{e)} (max. 1000 cycles per hour)	T_{2B}	Nm	55	42	39	42	42	42	42	42	39	42
		in.lb	487	372	345	372	372	372	372	372	345	372
Emergency stop torque ^{a) b) e)} (permitted 1000 times during the service life of the gearbox)	T_{2Not}	Nm	80	80	80	80	80	80	80	80	80	80
		in.lb	708	708	708	708	708	708	708	708	708	708
Permitted average input speed ^{d)} (at T_{2m} and 20 °C ambient temperature)	n_{1N}	rpm	2900	3100	3800	4000	3800	4000	4300	4600	4600	
Max. input speed	n_{1Max}	rpm	8000	8000	10000	10000	10000	10000	10000	10000	10000	
Mean no load running torque ^{b)} (at $n_1=3000$ rpm and 20 °C gearbox temperature)	T_{012}	Nm	0.92	0.74	0.34	0.29	0.29	0.25	0.21	0.21	0.19	
		in.lb	8.1	6.5	3	2.6	2.6	2.2	1.9	1.9	1.7	
Max. backlash	j_l	arcmin	≤ 8		≤ 10							
Torsional rigidity ^{b)}	C_{121}	Nm/arcmin	4	4	4	4	4	4	4	4	4	
		in.lb/arcmin	35	35	35	35	35	35	35	35	35	
Max. axial force ^{c)}	F_{2AMax}	N	2400		2400							
		lb _f	540		540							
Max. lateral force ^{c)}	F_{2QMMax}	N	2800		2800							
		lb _f	630		630							
Max. tilting moment	M_{2KMMax}	Nm	152		152							
		in.lb	1345		1345							
Efficiency at full load	η	%	97		95							
Service life	L_n	h	> 20000		> 20000							
Weight (incl. standard adapter plate)	m	kg	1.9		2							
		lb _m	4.2		4.4							
Operating noise (at reference ratio and reference speed – ratio-specific values available in cymex®)	L_{PA}	dB(A)	≤ 59		≤ 58							
Max. permitted housing temperature		°C	+90		+90							
		°F	+194		+194							
Ambient temperature		°C	-15 to +40		-15 to +40							
		°F	+5 to +104		+5 to +104							
Lubrication			Lubricated for life									
Direction of rotation			In- and output same direction									
Protection class			IP 65									
Elastomer coupling (recommended product type – validate sizing with cymex®)			ELC-0060BA016.000-X									
Bore diameter of coupling on the application side		mm	X = 012.000 - 032.000									
Mass moment of inertia (relates to the drive) Clamping hub diameter [mm]	Z	8	J_1	kgcm ²	-	-	0.04	0.04	0.03	0.03	0.03	0.03
				10 ⁻³ in.lb.s ²	-	-	0.04	0.04	0.03	0.03	0.03	0.03
	A	9	J_1	kgcm ²	0.25	0.19	0.04	0.04	0.03	0.03	0.03	0.03
				10 ⁻³ in.lb.s ²	0.22	0.17	0.04	0.04	0.03	0.03	0.03	0.03
	B	11	J_1	kgcm ²	0.26	0.21	0.06	0.06	0.05	0.05	0.05	0.05
				10 ⁻³ in.lb.s ²	0.23	0.19	0.05	0.05	0.04	0.04	0.04	0.04
	C	14	J_1	kgcm ²	0.34	0.28	0.14	0.14	0.14	0.13	0.13	0.14
				10 ⁻³ in.lb.s ²	0.3	0.25	0.12	0.12	0.12	0.12	0.12	0.12
	D	16	J_1	kgcm ²	0.47	0.41	-	-	-	-	-	-
				10 ⁻³ in.lb.s ²	0.42	0.36	-	-	-	-	-	-
	E	19	J_1	kgcm ²	0.55	0.49	-	-	-	-	-	-
				10 ⁻³ in.lb.s ²	0.49	0.43	-	-	-	-	-	-

Please use our sizing software cymex® for a detailed sizing – www.wittenstein-cymex.com

^{a)} Valid for torque transmission only

^{b)} Valid for standard clamping hub diameter

^{c)} Refers to center of the output shaft or flange

^{d)} Please reduce input speed at higher ambient temperatures

^{e)} Valid for: Smooth shaft

1-stage

up to 14⁴⁾ (C)⁵⁾
clamping hub diameter

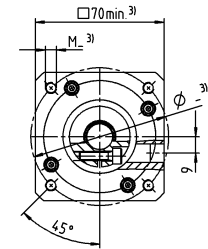
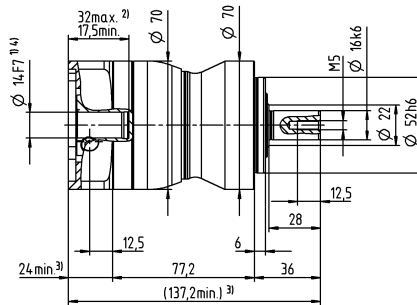
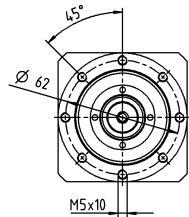

up to 19⁴⁾ (E)
clamping hub diameter

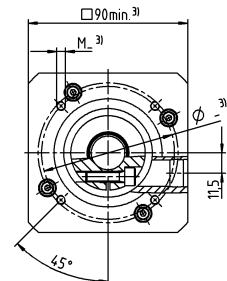
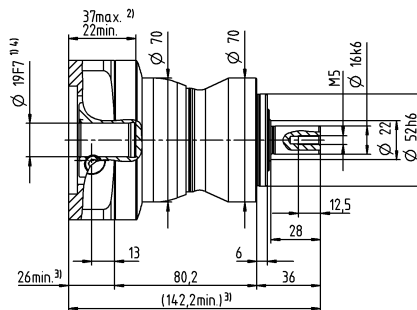
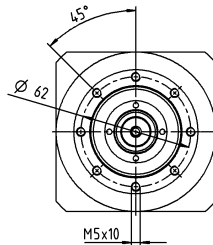

2-stage

up to 11⁴⁾ (B)⁵⁾
clamping hub diameter

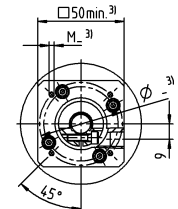
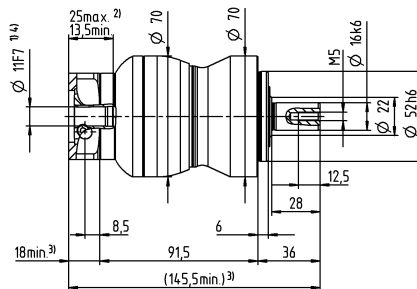
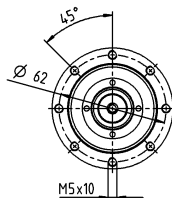

up to 14⁴⁾ (C)
clamping hub diameter

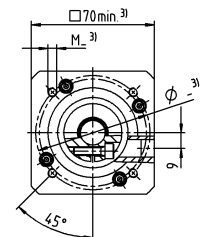
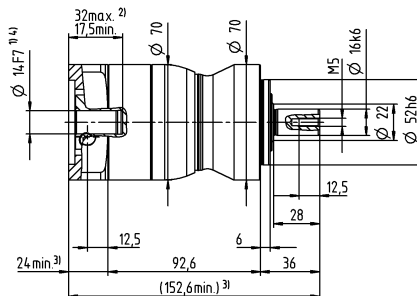
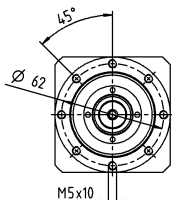

Motor shaft diameter [mm]

Other output variants

Shaft with key

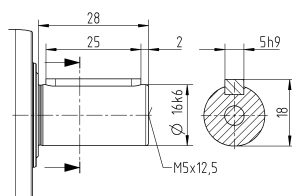

Splined shaft (DIN 5480)

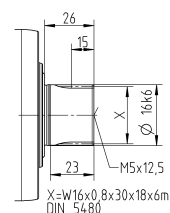

Non-tolerated dimensions are nominal dimensions

¹⁾ Check motor shaft fit

²⁾ Min. / Max. permissible motor shaft length

Longer motor shafts are possible, please contact alpha

³⁾ The dimensions depend on the motor

⁴⁾ Smaller motor shaft diameter is compensated

by a bushing with a minimum wall thickness of 1 mm

⁵⁾ Standard clamping hub diameter

NPL 025 MA 1-/2-stage

			1-stage		2-stage									
Ratio	i		3	4	9	12	15	16	20	28	30	40		
Max. torque ^{a) b) e)}	T_{2a}	Nm	185	185	185	185	185	185	185	185	168	185		
		in.lb	1637	1637	1637	1637	1637	1637	1637	1637	1637	1487	1637	
Max. acceleration torque ^{e)} (max. 1000 cycles per hour)	T_{2B}	Nm	125	115	125	125	120	115	115	115	105	115		
		in.lb	1106	1018	1106	1106	1062	1018	1018	1018	929	1018		
Emergency stop torque ^{a) b) e)} (permitted 1000 times during the service life of the gearbox)	T_{2Not}	Nm	190	190	190	190	190	190	190	190	190	190		
		in.lb	1682	1682	1682	1682	1682	1682	1682	1682	1682	1682		
Permitted average input speed ^{d)} (at T_{2a} and 20 °C ambient temperature)	n_{1N}	rpm	2700	2900	2900	3500	3700	3500	3700	4000	4300	4300		
Max. input speed	n_{1Max}	rpm	7000	7000	8000	8000	8000	8000	8000	8000	8000	8000		
Mean no load running torque ^{b)} (at $n_1=3000$ rpm and 20 °C gearbox temperature)	T_{012}	Nm	1.8	1.5	0.67	0.55	0.47	0.46	0.4	0.34	0.33	0.29		
		in.lb	16	13	5.9	4.9	4.2	4.1	3.5	3	2.9	2.6		
Max. backlash	j_l	arcmin	≤ 8		≤ 10									
Torsional rigidity ^{b)}	C_{i21}	Nm/arcmin	12	12	12	12	12	12	12	12	12	12		
		in.lb/arcmin	106	106	106	106	106	106	106	106	106	106		
Max. axial force ^{c)}	F_{2AMax}	N	3350		3350									
		lb _f	754		754									
Max. lateral force ^{c)}	F_{2QMMax}	N	4200		4200									
		lb _f	945		945									
Max. tilting moment	M_{2KMMax}	Nm	236		236									
		in.lb	2089		2089									
Efficiency at full load	η	%	97		95									
Service life	L_n	h	> 20000		> 20000									
Weight (incl. standard adapter plate)	m	kg	3.9		4.2									
		lb _m	8.6		9.3									
Operating noise (at reference ratio and reference speed – ratio-specific values available in cymex®)	L_{PA}	dB(A)	≤ 61		≤ 59									
			°C		+90		+90							
Max. permitted housing temperature			°F		+194		+194							
			°C		-15 to +40		-15 to +40							
Ambient temperature			°F		+5 to +104		+5 to +104							
			Lubricated for life											
Direction of rotation		In- and output same direction												
Protection class		IP 65												
Elastomer coupling (recommended product type – validate sizing with cymex®)		ELC-0060BA022.000-X												
Bore diameter of coupling on the application side		mm	X = 012.000 - 032.000											
Mass moment of inertia (relates to the drive) Clamping hub diameter [mm]	A	9	J_1	kgcm ²	-	-	0.26	0.22	0.21	0.21	0.2	0.19	0.19	0.19
				10 ⁻³ in.lb.s ²	-	-	0.23	0.19	0.19	0.19	0.18	0.17	0.17	0.17
	B	11	J_1	kgcm ²	-	-	0.28	0.24	0.23	0.23	0.22	0.21	0.21	0.21
				10 ⁻³ in.lb.s ²	-	-	0.25	0.21	0.2	0.2	0.19	0.19	0.19	0.19
	C	14	J_1	kgcm ²	0.58	0.47	0.35	0.31	0.3	0.3	0.3	0.29	0.28	0.28
				10 ⁻³ in.lb.s ²	0.51	0.42	0.31	0.27	0.27	0.27	0.27	0.26	0.25	0.25
	D	16	J_1	kgcm ²	0.73	0.62	0.48	0.44	0.43	0.43	0.42	0.41	0.41	0.41
				10 ⁻³ in.lb.s ²	0.65	0.55	0.42	0.39	0.38	0.38	0.37	0.36	0.36	0.36
	E	19	J_1	kgcm ²	0.81	0.71	0.56	0.52	0.51	0.52	0.51	0.5	0.5	0.49
				10 ⁻³ in.lb.s ²	0.72	0.63	0.5	0.46	0.45	0.46	0.45	0.44	0.44	0.43
	G	24	J_1	kgcm ²	1.8	1.7	-	-	-	-	-	-	-	-
				10 ⁻³ in.lb.s ²	1.6	1.5	-	-	-	-	-	-	-	-
	H	28	J_1	kgcm ²	1.6	1.4	-	-	-	-	-	-	-	-
				10 ⁻³ in.lb.s ²	1.4	1.2	-	-	-	-	-	-	-	-

Please use our sizing software cymex® for a detailed sizing – www.wittenstein-cymex.com

^{a)} Valid for torque transmission only

^{b)} Valid for standard clamping hub diameter

^{c)} Refers to center of the output shaft or flange

^{d)} Please reduce input speed at higher ambient temperatures

^{e)} Valid for: Smooth shaft

1-stage

up to 19⁴⁾ (E)⁵⁾
clamping hub diameter

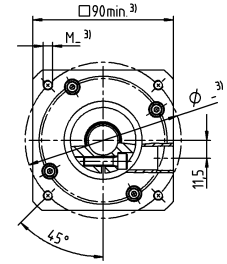
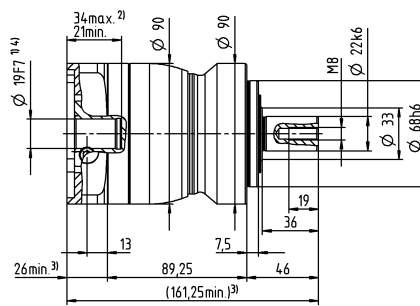
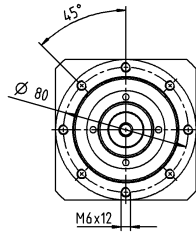

up to 28⁴⁾ (H)
clamping hub diameter

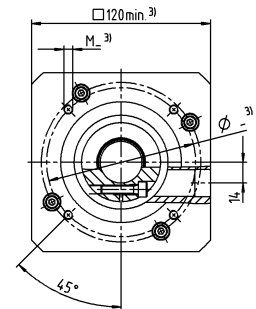
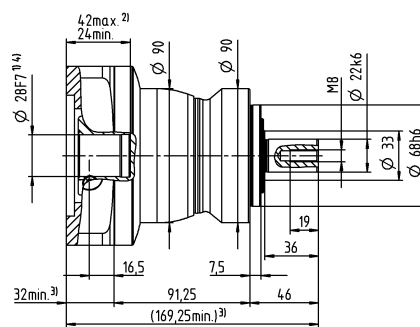
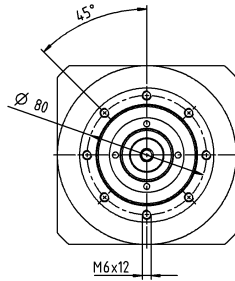

2-stage

up to 14⁴⁾ (C)⁵⁾
clamping hub diameter

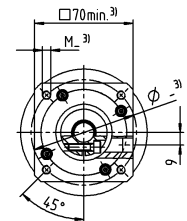
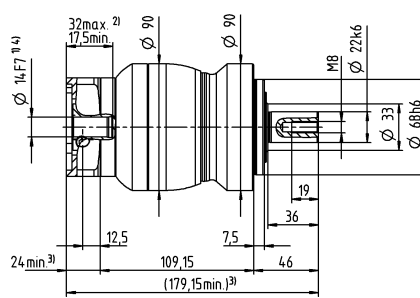
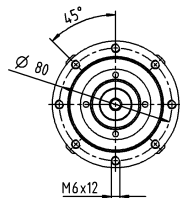

up to 19⁴⁾ (E)
clamping hub diameter

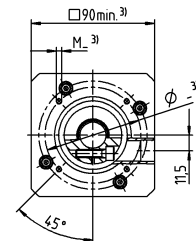
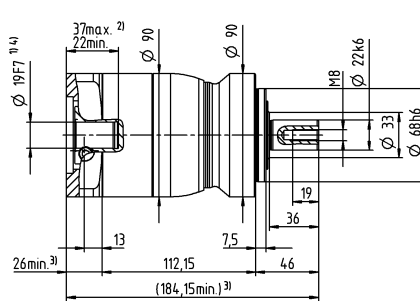
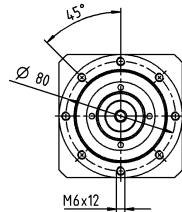

Motor shaft diameter [mm]

Other output variants

Shaft with key

Splined shaft (DIN 5480)

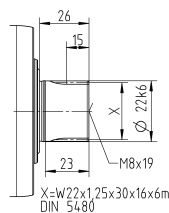
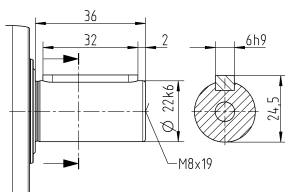

Non-tolerated dimensions are nominal dimensions

¹⁾ Check motor shaft fit

²⁾ Min. / Max. permissible motor shaft length

Longer motor shafts are possible, please contact alpha

³⁾ The dimensions depend on the motor

⁴⁾ Smaller motor shaft diameter is compensated

by a bushing with a minimum wall thickness of 1 mm

⁵⁾ Standard clamping hub diameter

NPL 035 MA 1-/2-stage

			1-stage		2-stage									
Ratio	i		3	4	9	12	15	16	20	28	30	40		
Max. torque ^{a) b) e)}	T_{2a}	Nm	480	480	480	480	480	480	480	480	432	480		
		in.lb	4248	4248	4248	4248	4248	4248	4248	4248	4248	3824	4248	
Max. acceleration torque ^{e)} (max. 1000 cycles per hour)	T_{2B}	Nm	305	305	305	305	300	305	305	305	270	305		
		in.lb	2699	2699	2699	2699	2655	2699	2699	2699	2390	2699		
Emergency stop torque ^{a) b) e)} (permitted 1000 times during the service life of the gearbox)	T_{2Not}	Nm	500	500	500	500	500	500	500	500	500	500		
		in.lb	4425	4425	4425	4425	4425	4425	4425	4425	4425	4425		
Permitted average input speed ^{d)} (at T_{2N} and 20 °C ambient temperature)	n_{1N}	rpm	2000	2200	2700	3300	3400	3300	3400	3600	3900	3900		
Max. input speed	n_{1Max}	rpm	6000	6000	7000	7000	7000	7000	7000	7000	7000	7000		
Mean no load running torque ^{b)} (at $n_1=3000$ rpm and 20 °C gearbox temperature)	T_{012}	Nm	3.3	2.7	1.7	1.4	1.2	1.2	1.1	0.93	0.88	0.81		
		in.lb	29	24	15	12	11	11	9.7	8.2	7.8	7.2		
Max. backlash	j_l	arcmin	≤ 8		≤ 10									
Torsional rigidity ^{b)}	C_{i21}	Nm/arcmin	30	30	30	30	30	30	30	30	30	30		
		in.lb/arcmin	266	266	266	266	266	266	266	266	266	266		
Max. axial force ^{c)}	F_{2AMax}	N	5650		5650									
		lb _f	1271		1271									
Max. lateral force ^{c)}	F_{2QMMax}	N	6600		6600									
		lb _f	1485		1485									
Max. tilting moment	M_{2KMMax}	Nm	487		487									
		in.lb	4310		4310									
Efficiency at full load	η	%	97		95									
Service life	L_n	h	> 20000		> 20000									
Weight (incl. standard adapter plate)	m	kg	9.1		9.5									
		lb _m	20		21									
Operating noise (at reference ratio and reference speed – ratio-specific values available in cymex®)	L_{PA}	dB(A)	≤ 65		≤ 61									
			+90		+90									
Max. permitted housing temperature		°C	+90		+90									
		°F	+194		+194									
Ambient temperature		°C	-15 to +40		-15 to +40									
		°F	+5 to +104		+5 to +104									
Lubrication			Lubricated for life											
Direction of rotation			In- and output same direction											
Protection class			IP 65											
Elastomer coupling (recommended product type – validate sizing with cymex®)			ELC-0150BA032.000-X											
Bore diameter of coupling on the application side		mm	X = 019.000 - 036.000											
Mass moment of inertia (relates to the drive) Clamping hub diameter [mm]	C	14	J_1	kgcm ²	-	-	0.6	0.59	0.6	0.43	0.42	0.37	0.52	0.36
				10 ⁻³ in.lb.s ²	-	-	0.53	0.52	0.53	0.38	0.37	0.33	0.46	0.32
	D	16	J_1	kgcm ²	-	-	0.75	0.74	0.74	0.58	0.57	0.5	0.67	0.51
				10 ⁻³ in.lb.s ²	-	-	0.66	0.65	0.65	0.51	0.5	0.44	0.59	0.45
	E	19	J_1	kgcm ²	2.5	1.7	0.84	0.83	0.83	0.66	0.65	0.6	0.75	0.6
				10 ⁻³ in.lb.s ²	2.2	1.5	0.74	0.73	0.73	0.58	0.58	0.53	0.66	0.53
	G	24	J_1	kgcm ²	3.3	2.4	1.9	1.9	1.9	1.7	1.7	1.6	1.8	1.6
				10 ⁻³ in.lb.s ²	2.9	2.1	1.7	1.6	1.7	1.5	1.5	1.5	1.6	1.4
	H	28	J_1	kgcm ²	3	2.2	1.6	1.6	1.6	1.4	1.4	1.3	1.5	1.3
				10 ⁻³ in.lb.s ²	2.7	1.9	1.4	1.4	1.4	1.2	1.2	1.2	1.3	1.2
	I	32	J_1	kgcm ²	7.1	6.2	-	-	-	-	-	-	-	-
				10 ⁻³ in.lb.s ²	6.3	5.5	-	-	-	-	-	-	-	-
K	38	J_1	kgcm ²	8.3	7.4	-	-	-	-	-	-	-	-	
			10 ⁻³ in.lb.s ²	7.3	6.5	-	-	-	-	-	-	-	-	

Please use our sizing software cymex® for a detailed sizing – www.wittenstein-cymex.com

^{a)} Valid for torque transmission only

^{b)} Valid for standard clamping hub diameter

^{c)} Refers to center of the output shaft or flange

^{d)} Please reduce input speed at higher ambient temperatures

^{e)} Valid for: Smooth shaft

1-stage

up to 24/28⁴⁾
(G⁵⁾/H)
clamping hub
diameter

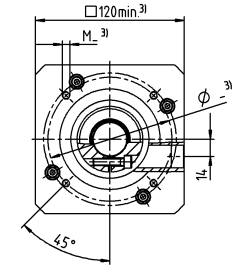
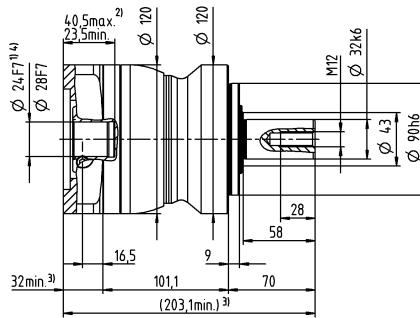
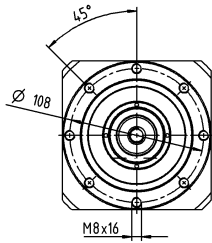

up to 38⁴⁾ (K)
clamping hub
diameter

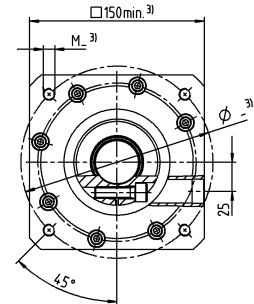
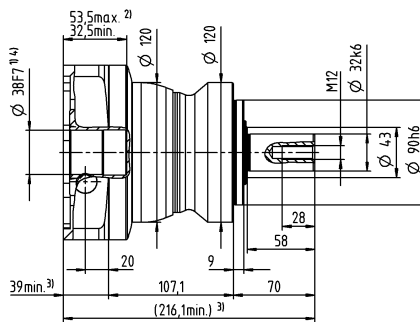
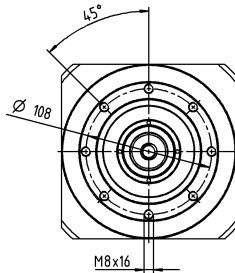

2-stage

up to 19⁴⁾ (E)⁵⁾
clamping hub
diameter

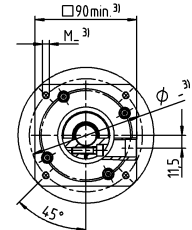
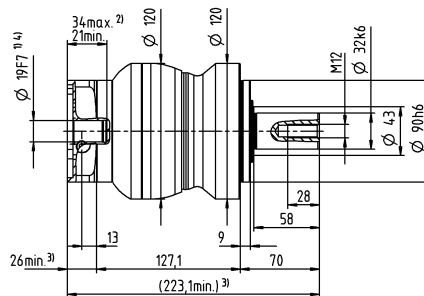
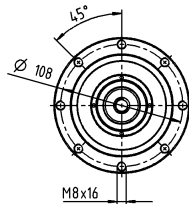

up to 28⁴⁾ (H)
clamping hub
diameter

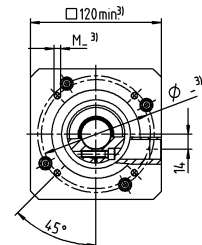
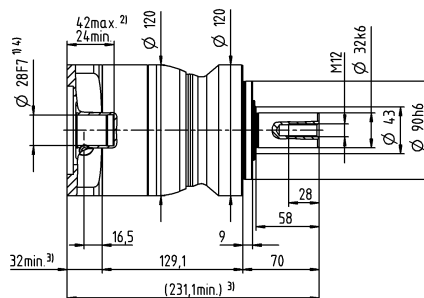
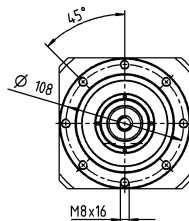

Motor shaft diameter [mm]

Other output variants

Shaft with key

Splined shaft (DIN 5480)

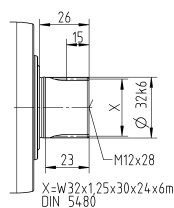
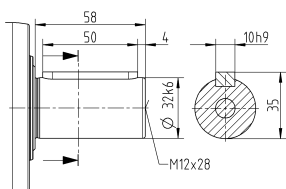

Non-tolerated dimensions are nominal dimensions

¹⁾ Check motor shaft fit

²⁾ Min. / Max. permissible motor shaft length

Longer motor shafts are possible, please contact alpha

³⁾ The dimensions depend on the motor

⁴⁾ Smaller motor shaft diameter is compensated

by a bushing with a minimum wall thickness of 1 mm

⁵⁾ Standard clamping hub diameter

NPS 015 MF 1-stage

			1-stage							
Ratio	i		3	4	5	7	8	10		
Max. torque ^{a) b) e)}	T_{2a}	Nm	51	56	64	64	56	56		
		in.lb	451	496	566	566	496	496		
Max. acceleration torque ^{e)} (max. 1000 cycles per hour)	T_{2B}	Nm	32	35	40	40	35	35		
		in.lb	283	310	354	354	310	310		
Emergency stop torque ^{a) b) e)} (permitted 1000 times during the service life of the gearbox)	T_{2Not}	Nm	80	80	80	80	80	80		
		in.lb	708	708	708	708	708	708		
Permitted average input speed ^{d)} (at T_{2a} and 20 °C ambient temperature)	n_{1N}	rpm	2900	3100	3300	3600	3600	3800		
Max. input speed	n_{1Max}	rpm	8000	8000	8000	8000	8000	8000		
Mean no load running torque ^{b)} (at $n_1=3000$ rpm and 20 °C gearbox temperature)	T_{012}	Nm	0.92	0.74	0.62	0.51	0.47	0.41		
		in.lb	8.1	6.5	5.5	4.5	4.2	3.6		
Max. backlash	j_l	arcmin	≤ 8							
Torsional rigidity ^{b)}	C_{i21}	Nm/arcmin	3.3	3.3	3.3	3.3	2.8	2.8		
		in.lb/arcmin	29	29	29	29	25	25		
Max. axial force ^{c)}	F_{2AMax}	N	2400							
		lb _f	540							
Max. lateral force ^{c)}	F_{2QMMax}	N	2800							
		lb _f	630							
Max. tilting moment	M_{2KMMax}	Nm	152							
		in.lb	1345							
Efficiency at full load	η	%	97							
Service life	L_n	h	> 20000							
Weight (incl. standard adapter plate)	m	kg	1.8							
		lb _m	4							
Operating noise (at reference ratio and reference speed – ratio-specific values available in cymex [®])	L_{PA}	dB(A)	≤ 59							
Max. permitted housing temperature		°C	+90							
		°F	+194							
Ambient temperature		°C	-15 to +40							
		°F	+5 to +104							
Lubrication			Lubricated for life							
Direction of rotation			In- and output same direction							
Protection class			IP 65							
Elastomer coupling (recommended product type – validate sizing with cymex [®])			ELC-0060BA016.000-X							
Bore diameter of coupling on the application side		mm	X = 012.000 - 032.000							
Mass moment of inertia (relates to the drive) Clamping hub diameter [mm]	A	9	J_1	kgcm ²	0.25	0.19	0.17	0.14	0.14	0.13
				10 ⁻³ in.lb.s ²	0.22	0.17	0.15	0.12	0.12	0.12
	B	11	J_1	kgcm ²	0.26	0.21	0.18	0.16	0.16	0.15
				10 ⁻³ in.lb.s ²	0.23	0.19	0.16	0.14	0.14	0.13
	C	14	J_1	kgcm ²	0.34	0.28	0.26	0.24	0.23	0.23
				10 ⁻³ in.lb.s ²	0.3	0.25	0.23	0.21	0.2	0.2
	D	16	J_1	kgcm ²	0.47	0.41	0.39	0.36	0.36	0.35
				10 ⁻³ in.lb.s ²	0.42	0.36	0.35	0.32	0.32	0.31
	E	19	J_1	kgcm ²	0.55	0.49	0.47	0.45	0.44	0.44
				10 ⁻³ in.lb.s ²	0.49	0.43	0.42	0.4	0.39	0.39

Please use our sizing software cymex[®] for a detailed sizing – www.wittenstein-cymex.com

^{a)} Valid for torque transmission only

^{b)} Valid for standard clamping hub diameter

^{c)} Refers to center of the output shaft or flange

^{d)} Please reduce input speed at higher ambient temperatures

^{e)} Valid for: Smooth shaft

1-stage

Motor shaft diameter [mm]

up to 14⁴⁾ (C)⁵⁾
clamping hub diameter

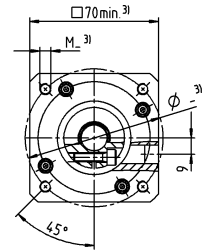
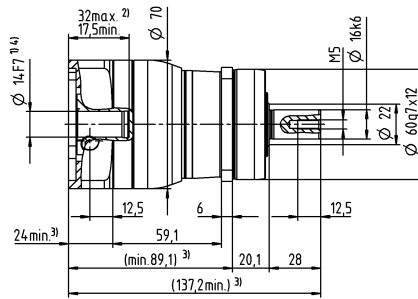
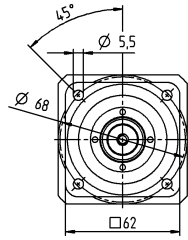

up to 19⁴⁾ (E)
clamping hub diameter

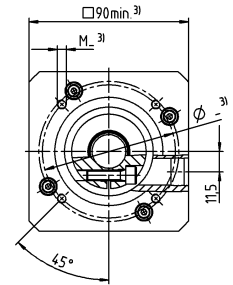
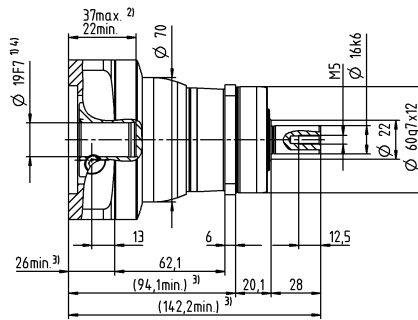
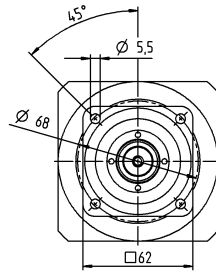

Other output variants

Shaft with key

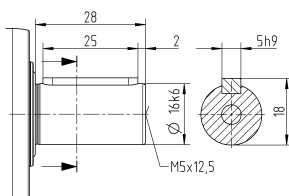

Splined shaft (DIN 5480)

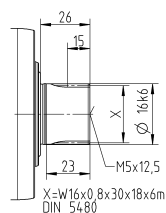

Non-tolerated dimensions are nominal dimensions

¹⁾ Check motor shaft fit

²⁾ Min. / Max. permissible motor shaft length

Longer motor shafts are possible, please contact alpha

³⁾ The dimensions depend on the motor

⁴⁾ Smaller motor shaft diameter is compensated by a bushing with a minimum wall thickness of 1 mm

⁵⁾ Standard clamping hub diameter

NPS 015 MF 2-stage

			2-stage														
Ratio	i		12	15	16	20	25	28	30	32	35	40	50	64	70	100	
Max. torque ^{a) b) e)}	T_{2a}	Nm	51	51	56	56	64	56	51	56	64	56	64	56	64	56	
		in.lb	451	451	496	496	566	496	451	496	566	496	566	496	566	496	566
Max. acceleration torque ^{e)} (max. 1000 cycles per hour)	T_{2B}	Nm	32	32	35	35	40	35	32	35	40	35	40	35	40	35	
		in.lb	283	283	310	310	354	310	283	310	354	310	354	310	354	310	
Emergency stop torque ^{a) b) e)} (permitted 1000 times during the service life of the gearbox)	T_{2Not}	Nm	80	80	80	80	80	80	80	80	80	80	80	80	80	80	
		in.lb	708	708	708	708	708	708	708	708	708	708	708	708	708	708	
Permitted average input speed ^{d)} (at T_{2a} and 20 °C ambient temperature)	n_{1N}	rpm	3800	4000	3800	4000	4000	4300	4600	4400	4300	4600	4600	4400	4600	4600	
Max. input speed	n_{1Max}	rpm	10000	10000	10000	10000	10000	10000	10000	10000	10000	10000	10000	10000	10000	10000	
Mean no load running torque ^{b)} (at $n_1=3000$ rpm and 20 °C gearbox temperature)	T_{012}	Nm	0.34	0.29	0.29	0.25	0.23	0.21	0.21	0.2	0.2	0.19	0.17	0.17	0.16	0.15	
		in.lb	3	2.6	2.6	2.2	2	1.9	1.9	1.8	1.8	1.7	1.5	1.5	1.4	1.3	
Max. backlash	j_l	arcmin	≤ 10														
Torsional rigidity ^{b)}	C_{i21}	Nm/arcmin	3.3	3.3	3.3	3.3	3.3	3.3	3.3	3.3	3.3	3.3	3.3	2.8	3.3	2.8	
		in.lb/arcmin	29	29	29	29	29	29	29	29	29	29	29	25	29	25	
Max. axial force ^{c)}	F_{2AMax}	N	2400														
		lb _f	540														
Max. lateral force ^{c)}	F_{2QMMax}	N	2800														
		lb _f	630														
Max. tilting moment	M_{2KMMax}	Nm	152														
		in.lb	1345														
Efficiency at full load	η	%	95														
Service life	L_n	h	> 20000														
Weight (incl. standard adapter plate)	m	kg	1.9														
		lb _m	4.2														
Operating noise (at reference ratio and reference speed – ratio-specific values available in cymex [®])	L_{PA}	dB(A)	≤ 58														
Max. permitted housing temperature		°C	+90														
		°F	+194														
Ambient temperature		°C	-15 to +40														
		°F	+5 to +104														
Lubrication			Lubricated for life														
Direction of rotation			In- and output same direction														
Protection class			IP 65														
Elastomer coupling (recommended product type – validate sizing with cymex [®])			ELC-0060BA016.000-X														
Bore diameter of coupling on the application side		mm	X = 012.000 - 032.000														
Mass moment of inertia (relates to the drive) Clamping hub diameter [mm]	Z	8	J_1	kgcm ²	0.04	0.04	0.03	0.03	0.03	0.03	0.03	0.03	0.03	0.02	0.02	0.02	0.02
				10 ⁻³ in.lb.s ²	0.04	0.04	0.03	0.03	0.03	0.03	0.03	0.03	0.03	0.03	0.02	0.02	0.02
	A	9	J_1	kgcm ²	0.04	0.04	0.03	0.03	0.03	0.03	0.03	0.03	0.03	0.02	0.02	0.02	0.02
				10 ⁻³ in.lb.s ²	0.04	0.04	0.03	0.03	0.03	0.03	0.03	0.03	0.03	0.02	0.02	0.02	0.02
	B	11	J_1	kgcm ²	0.06	0.06	0.05	0.05	0.05	0.05	0.05	0.04	0.05	0.04	0.04	0.04	
				10 ⁻³ in.lb.s ²	0.05	0.05	0.04	0.04	0.04	0.04	0.04	0.04	0.04	0.04	0.04	0.04	
	C	14	J_1	kgcm ²	0.14	0.14	0.14	0.13	0.13	0.13	0.14	0.13	0.13	0.13	0.13	0.13	
				10 ⁻³ in.lb.s ²	0.12	0.12	0.12	0.12	0.12	0.12	0.12	0.12	0.12	0.12	0.12	0.12	

Please use our sizing software cymex[®] for a detailed sizing – www.wittenstein-cymex.com

^{a)} Valid for torque transmission only

^{b)} Valid for standard clamping hub diameter

^{c)} Refers to center of the output shaft or flange

^{d)} Please reduce input speed at higher ambient temperatures

^{e)} Valid for: Smooth shaft

2-stage

Motor shaft diameter [mm]

up to 11⁴⁾ (B)⁵⁾
clamping hub diameter

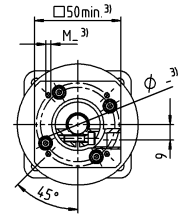
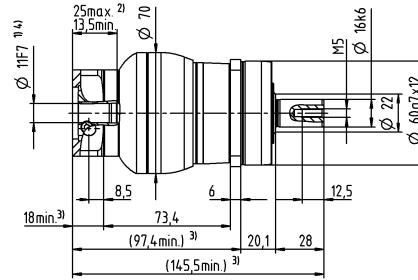
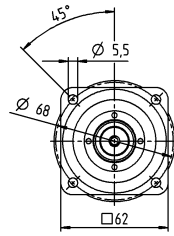

up to 14⁴⁾ (C)
clamping hub diameter

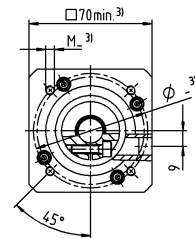
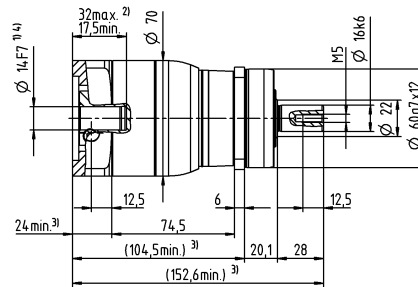
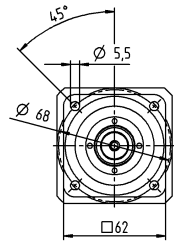

Planetary Gearboxes
Value Line

Other output variants

Shaft with key

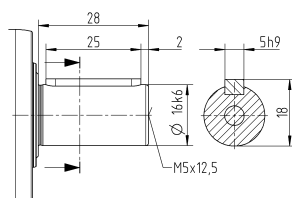

Splined shaft (DIN 5480)

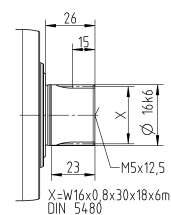

Non-tolerated dimensions are nominal dimensions

¹⁾ Check motor shaft fit

²⁾ Min. / Max. permissible motor shaft length

Longer motor shafts are possible, please contact alpha

³⁾ The dimensions depend on the motor

⁴⁾ Smaller motor shaft diameter is compensated

by a bushing with a minimum wall thickness of 1 mm

⁵⁾ Standard clamping hub diameter

NPS 025 MF 1-stage

			1-stage							
Ratio	i		3	4	5	7	8	10		
Max. torque ^{a) b) e)}	T_{2a}	Nm	128	152	160	160	144	144		
		in.lb	1133	1345	1416	1416	1275	1275		
Max. acceleration torque ^{e)} (max. 1000 cycles per hour)	T_{2B}	Nm	80	95	100	100	90	90		
		in.lb	708	841	885	885	797	797		
Emergency stop torque ^{a) b) e)} (permitted 1000 times during the service life of the gearbox)	T_{2Not}	Nm	190	190	190	190	190	190		
		in.lb	1682	1682	1682	1682	1682	1682		
Permitted average input speed ^{d)} (at T_{2a} and 20 °C ambient temperature)	n_{1N}	rpm	2700	2900	3000	3200	3300	3500		
Max. input speed	n_{1Max}	rpm	7000	7000	7000	7000	7000	7000		
Mean no load running torque ^{b)} (at $n_1=3000$ rpm and 20 °C gearbox temperature)	T_{012}	Nm	1.8	1.5	1.3	1.1	1	0.94		
		in.lb	16	13	12	9.7	8.9	8.3		
Max. backlash	j_l	arcmin	≤ 8							
Torsional rigidity ^{b)}	C_{i21}	Nm/arcmin	9.5	9.5	9.5	9.5	8.5	8.5		
		in.lb/arcmin	84	84	84	84	75	75		
Max. axial force ^{c)}	F_{2AMax}	N	3350							
		lb _f	754							
Max. lateral force ^{c)}	F_{2QMMax}	N	4200							
		lb _f	945							
Max. tilting moment	M_{2KMMax}	Nm	236							
		in.lb	2089							
Efficiency at full load	η	%	97							
Service life	L_n	h	> 20000							
Weight (incl. standard adapter plate)	m	kg	3.6							
		lb _m	8							
Operating noise (at reference ratio and reference speed – ratio-specific values available in cymex [®])	L_{PA}	dB(A)	≤ 61							
Max. permitted housing temperature		°C	+90							
		°F	+194							
Ambient temperature		°C	-15 to +40							
		°F	+5 to +104							
Lubrication			Lubricated for life							
Direction of rotation			In- and output same direction							
Protection class			IP 65							
Elastomer coupling (recommended product type – validate sizing with cymex [®])			ELC-0060BA022.000-X							
Bore diameter of coupling on the application side		mm	X = 012.000 - 032.000							
Mass moment of inertia (relates to the drive) Clamping hub diameter [mm]	C	14	J_1	kgcm ²	0.58	0.47	0.38	0.3	0.28	0.26
				10 ⁻³ in.lb.s ²	0.51	0.42	0.34	0.27	0.25	0.23
	D	16	J_1	kgcm ²	0.73	0.62	0.53	0.43	0.42	0.4
				10 ⁻³ in.lb.s ²	0.65	0.55	0.47	0.38	0.37	0.35
	E	19	J_1	kgcm ²	0.81	0.71	0.61	0.53	0.51	0.49
				10 ⁻³ in.lb.s ²	0.72	0.63	0.54	0.47	0.45	0.43
	G	24	J_1	kgcm ²	1.8	1.7	1.6	1.6	1.5	1.5
				10 ⁻³ in.lb.s ²	1.6	1.5	1.4	1.4	1.3	1.3
	H	28	J_1	kgcm ²	1.6	1.4	1.4	1.3	1.3	1.2
				10 ⁻³ in.lb.s ²	1.4	1.2	1.2	1.2	1.2	1.1

Please use our sizing software cymex[®] for a detailed sizing – www.wittenstein-cymex.com

^{a)} Valid for torque transmission only

^{b)} Valid for standard clamping hub diameter

^{c)} Refers to center of the output shaft or flange

^{d)} Please reduce input speed at higher ambient temperatures

^{e)} Valid for: Smooth shaft

1-stage

up to 19⁴⁾ (E)⁵⁾
clamping hub
diameter

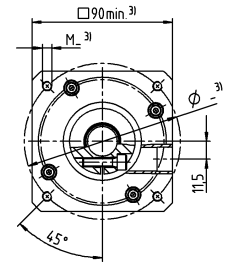
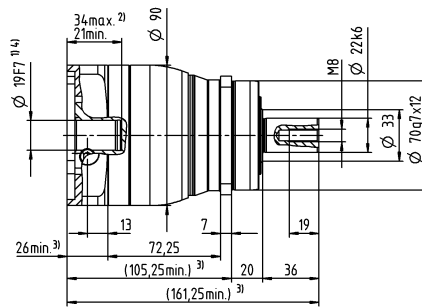
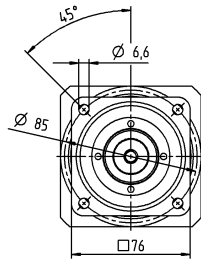

Motor shaft diameter [mm]

up to 28⁴⁾ (H)
clamping hub
diameter

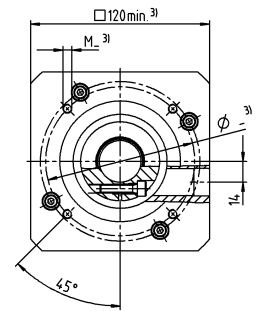
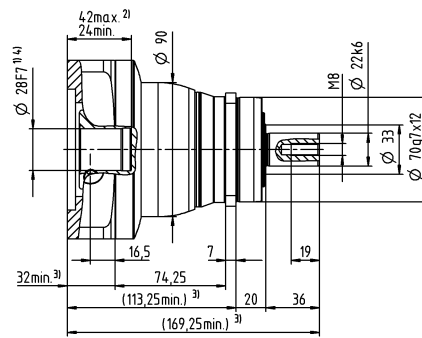
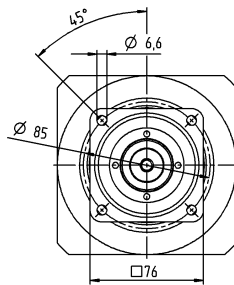

Other output variants

Shaft with key

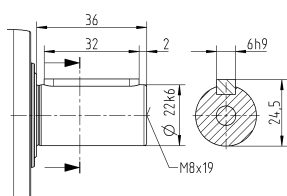

Splined shaft (DIN 5480)

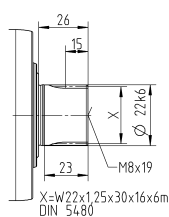

Non-tolerated dimensions are nominal dimensions

¹⁾ Check motor shaft fit

²⁾ Min. / Max. permissible motor shaft length

Longer motor shafts are possible, please contact alpha

³⁾ The dimensions depend on the motor

⁴⁾ Smaller motor shaft diameter is compensated

by a bushing with a minimum wall thickness of 1 mm

⁵⁾ Standard clamping hub diameter

NPS 025 MF 2-stage

			2-stage														
Ratio	i		9	12	15	16	20	25	28	30	32	35	40	50	64	70	100
Max. torque ^{a) b) e)}	T_{2a}	Nm	128	128	128	152	152	160	152	128	144	160	152	160	144	160	144
		in.lb	1133	1133	1133	1345	1345	1416	1345	1133	1275	1416	1345	1416	1275	1416	1275
Max. acceleration torque ^{e)} (max. 1000 cycles per hour)	T_{2B}	Nm	80	80	80	95	95	100	95	80	90	100	95	100	90	100	90
		in.lb	708	708	708	841	841	885	841	708	797	885	841	885	797	885	797
Emergency stop torque ^{a) b) e)} (permitted 1000 times during the service life of the gearbox)	T_{2Not}	Nm	190	190	190	190	190	190	190	190	190	190	190	190	190	190	190
		in.lb	1682	1682	1682	1682	1682	1682	1682	1682	1682	1682	1682	1682	1682	1682	1682
Permitted average input speed ^{d)} (at T_{2N} and 20 °C ambient temperature)	n_{1N}	rpm	2900	3500	3700	3500	3700	3700	4000	4300	4100	4000	4300	4300	4100	4300	4300
Max. input speed	n_{1Max}	rpm	8000	8000	8000	8000	8000	8000	8000	8000	8000	8000	8000	8000	8000	8000	8000
Mean no load running torque ^{b)} (at $n_1=3000$ rpm and 20 °C gearbox temperature)	T_{012}	Nm	0.67	0.55	0.47	0.46	0.4	0.36	0.34	0.33	0.32	0.31	0.29	0.27	0.25	0.25	0.23
		in.lb	5.9	4.9	4.2	4.1	3.5	3.2	3	2.9	2.8	2.7	2.6	2.4	2.2	2.2	2
Max. backlash	j_t	arcmin	≤ 10														
Torsional rigidity ^{b)}	C_{t21}	Nm/arcmin	10	10	10	10	10	9.5	10	10	10	9.5	10	9.5	8.5	9.5	8.5
		in.lb/arcmin	89	89	89	89	89	84	89	89	89	84	89	84	75	84	75
Max. axial force ^{c)}	F_{2AMax}	N	3350														
		lb _f	754														
Max. lateral force ^{c)}	F_{2QMMax}	N	4200														
		lb _f	945														
Max. tilting moment	M_{2KMMax}	Nm	236														
		in.lb	2089														
Efficiency at full load	η	%	95														
Service life	L_n	h	> 20000														
Weight (incl. standard adapter plate)	m	kg	3.9														
		lb _m	8.6														
Operating noise (at reference ratio and reference speed – ratio-specific values available in cymex [®])	L_{PA}	dB(A)	≤ 59														
Max. permitted housing temperature		°C	+90														
		°F	+194														
Ambient temperature		°C	-15 to +40														
		°F	+5 to +104														
Lubrication			Lubricated for life														
Direction of rotation			In- and output same direction														
Protection class			IP 65														
Elastomer coupling (recommended product type – validate sizing with cymex [®])			ELC-0060BA022.000-X														
Bore diameter of coupling on the application side		mm	X = 012.000 - 032.000														
Mass moment of inertia (relates to the drive) Clamping hub diameter [mm]	A	9	J_t	kgcm ²	0.26	0.22	0.21	0.21	0.2	0.2	0.19	0.19	0.19	0.19	0.19	0.19	0.19
				10 ⁻³ in.lb.s ²	0.23	0.19	0.19	0.19	0.18	0.18	0.17	0.17	0.17	0.17	0.17	0.17	0.17
	B	11	J_t	kgcm ²	0.28	0.24	0.23	0.23	0.22	0.22	0.21	0.21	0.21	0.21	0.21	0.21	0.21
				10 ⁻³ in.lb.s ²	0.25	0.21	0.2	0.2	0.19	0.19	0.19	0.19	0.19	0.19	0.19	0.19	0.19
	C	14	J_t	kgcm ²	0.35	0.31	0.3	0.3	0.3	0.29	0.29	0.28	0.28	0.28	0.28	0.28	0.28
				10 ⁻³ in.lb.s ²	0.31	0.27	0.27	0.27	0.27	0.26	0.26	0.25	0.25	0.25	0.25	0.25	0.25
	D	16	J_t	kgcm ²	0.48	0.44	0.43	0.43	0.42	0.42	0.41	0.41	0.41	0.41	0.41	0.41	0.41
				10 ⁻³ in.lb.s ²	0.42	0.39	0.38	0.38	0.37	0.37	0.36	0.36	0.36	0.36	0.36	0.36	0.36
	E	19	J_t	kgcm ²	0.56	0.52	0.51	0.52	0.51	0.5	0.5	0.5	0.5	0.5	0.49	0.49	0.49
				10 ⁻³ in.lb.s ²	0.5	0.46	0.45	0.46	0.45	0.44	0.44	0.44	0.44	0.44	0.43	0.43	0.43

Please use our sizing software cymex[®] for a detailed sizing – www.wittenstein-cymex.com

^{a)} Valid for torque transmission only

^{b)} Valid for standard clamping hub diameter

^{c)} Refers to center of the output shaft or flange

^{d)} Please reduce input speed at higher ambient temperatures

^{e)} Valid for: Smooth shaft

2-stage

Motor shaft diameter [mm]

up to 14⁴⁾ (C)⁵⁾
clamping hub diameter

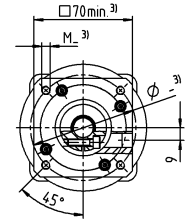
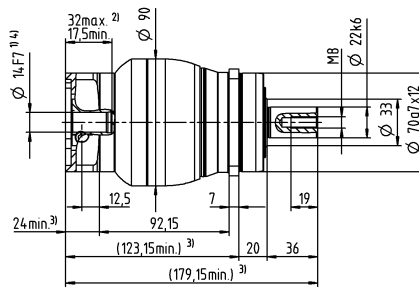
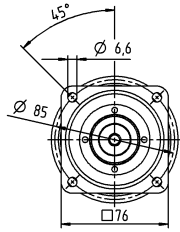

up to 19⁴⁾ (E)
clamping hub diameter

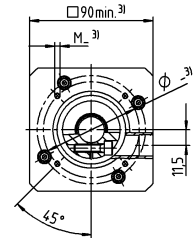
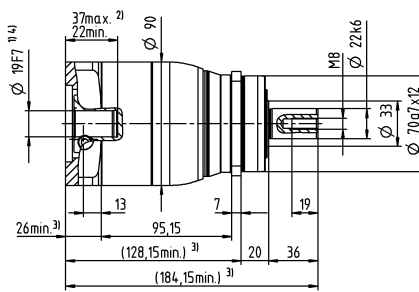
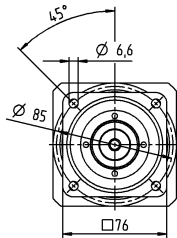

Planetary Gearboxes
Value Line

Other output variants

Shaft with key

Splined shaft (DIN 5480)

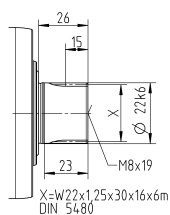
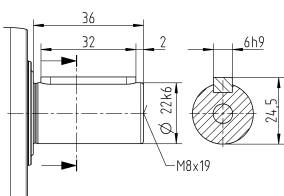

Non-tolerated dimensions are nominal dimensions

¹⁾ Check motor shaft fit

²⁾ Min. / Max. permissible motor shaft length

Longer motor shafts are possible, please contact alpha

³⁾ The dimensions depend on the motor

⁴⁾ Smaller motor shaft diameter is compensated

by a bushing with a minimum wall thickness of 1 mm

⁵⁾ Standard clamping hub diameter

NPS 035 MF 1-stage

			1-stage							
Ratio	i		3	4	5	7	8	10		
Max. torque ^{a) b) e)}	T_{2a}	Nm	320	408	400	400	352	352		
		in.lb	2832	3611	3540	3540	3115	3115		
Max. acceleration torque ^{e)} (max. 1000 cycles per hour)	T_{2B}	Nm	200	255	250	250	220	220		
		in.lb	1770	2257	2213	2213	1947	1947		
Emergency stop torque ^{a) b) e)} (permitted 1000 times during the service life of the gearbox)	T_{2Not}	Nm	500	500	500	500	500	500		
		in.lb	4425	4425	4425	4425	4425	4425		
Permitted average input speed ^{d)} (at T_{2a} and 20 °C ambient temperature)	n_{1N}	rpm	2000	2200	2300	2500	2600	2700		
Max. input speed	n_{1Max}	rpm	6000	6000	6000	6000	6000	6000		
Mean no load running torque ^{b)} (at $n_1=3000$ rpm and 20 °C gearbox temperature)	T_{012}	Nm	3.3	2.7	2.3	1.9	1.7	1.5		
		in.lb	29	24	20	17	15	13		
Max. backlash	j_l	arcmin	≤ 8							
Torsional rigidity ^{b)}	C_{t21}	Nm/arcmin	25	25	25	25	22	22		
		in.lb/arcmin	221	221	221	221	195	195		
Max. axial force ^{c)}	F_{2AMax}	N	5650							
		lb _f	1271							
Max. lateral force ^{c)}	F_{2QMMax}	N	6600							
		lb _f	1485							
Max. tilting moment	M_{2KMMax}	Nm	487							
		in.lb	4310							
Efficiency at full load	η	%	97							
Service life	L_n	h	> 20000							
Weight (incl. standard adapter plate)	m	kg	8.4							
		lb _m	19							
Operating noise (at reference ratio and reference speed – ratio-specific values available in cymex [®])	L_{PA}	dB(A)	≤ 65							
Max. permitted housing temperature		°C	+90							
		°F	+194							
Ambient temperature		°C	-15 to +40							
		°F	+5 to +104							
Lubrication			Lubricated for life							
Direction of rotation			In- and output same direction							
Protection class			IP 65							
Elastomer coupling (recommended product type – validate sizing with cymex [®])			ELC-0150BA032.000-X							
Bore diameter of coupling on the application side		mm	X = 019.000 - 036.000							
Mass moment of inertia (relates to the drive) Clamping hub diameter [mm]	E	19	J_1	kgcm ²	2.5	1.7	1.3	1	0.94	0.87
				10 ⁻³ in.lb.s ²	2.2	1.5	1.2	0.89	0.83	0.77
	G	24	J_1	kgcm ²	3.3	2.4	2.1	1.8	1.7	1.6
				10 ⁻³ in.lb.s ²	2.9	2.1	1.9	1.6	1.5	1.4
	H	28	J_1	kgcm ²	3	2.2	1.8	1.5	1.4	1.4
				10 ⁻³ in.lb.s ²	2.7	1.9	1.6	1.3	1.2	1.2
	I	32	J_1	kgcm ²	7.1	6.2	5.9	5.6	5.5	5.4
				10 ⁻³ in.lb.s ²	6.3	5.5	5.2	5	4.9	4.8
	K	38	J_1	kgcm ²	8.3	7.4	7.1	6.7	6.6	6.6
				10 ⁻³ in.lb.s ²	7.3	6.5	6.3	5.9	5.8	5.8

Please use our sizing software cymex[®] for a detailed sizing – www.wittenstein-cymex.com

^{a)} Valid for torque transmission only

^{b)} Valid for standard clamping hub diameter

^{c)} Refers to center of the output shaft or flange

^{d)} Please reduce input speed at higher ambient temperatures

^{e)} Valid for: Smooth shaft

1-stage

up to 24/28⁴⁾
(G⁵⁾/H)
clamping hub
diameter

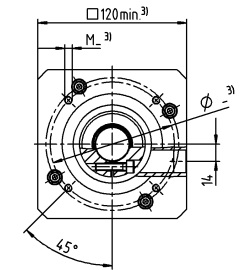
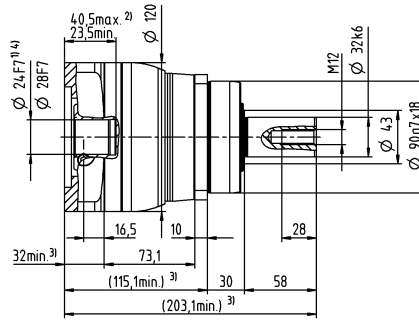
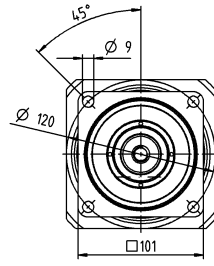

Motor shaft diameter [mm]

1-stage

up to 38⁴⁾ (K)
clamping hub
diameter

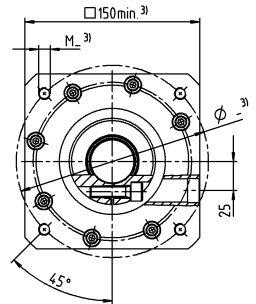
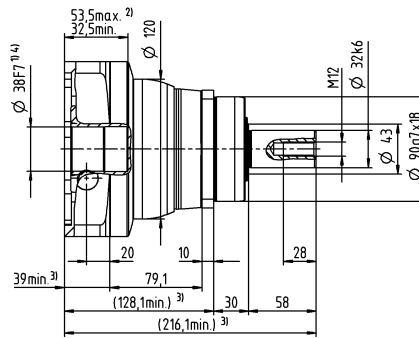
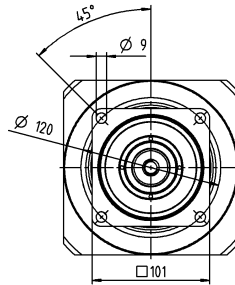

Planetary Gearboxes
Value Line

Other output variants

Shaft with key

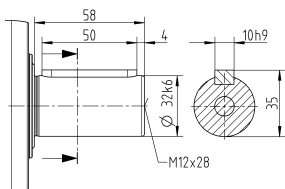

Splined shaft (DIN 5480)

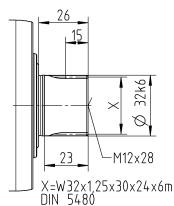

Non-tolerated dimensions are nominal dimensions

¹⁾ Check motor shaft fit

²⁾ Min. / Max. permissible motor shaft length

Longer motor shafts are possible, please contact alpha

³⁾ The dimensions depend on the motor

⁴⁾ Smaller motor shaft diameter is compensated by a bushing with a minimum wall thickness of 1 mm

⁵⁾ Standard clamping hub diameter

NPS 035 MF 2-stage

			2-stage																
Ratio	i		9	12	15	16	20	25	28	30	32	35	40	50	64	70	100		
Max. torque ^{a) b) e)}	T_{2a}	Nm	320	320	320	408	408	400	408	320	408	400	408	400	352	400	352		
		in.lb	2832	2832	2832	3611	3611	3540	3611	2832	3611	3540	3611	3540	3115	3540	3115		
Max. acceleration torque ^{e)} (max. 1000 cycles per hour)	T_{2B}	Nm	200	200	200	255	255	250	255	200	255	250	255	250	220	250	220		
		in.lb	1770	1770	1770	2257	2257	2213	2257	1770	2257	2213	2257	2213	1947	2213	1947		
Emergency stop torque ^{a) b) e)} (permitted 1000 times during the service life of the gearbox)	T_{2Not}	Nm	500	500	500	500	500	500	500	500	500	500	500	500	500	500	500		
		in.lb	4425	4425	4425	4425	4425	4425	4425	4425	4425	4425	4425	4425	4425	4425	4425		
Permitted average input speed ^{d)} (at T_{2a} and 20 °C ambient temperature)	n_{1N}	rpm	2700	3300	3400	3300	3400	3400	3600	3900	3700	3600	3900	3900	3700	3900	3900		
Max. input speed	n_{1Max}	rpm	7000	7000	7000	7000	7000	7000	7000	7000	7000	7000	7000	7000	7000	7000	7000		
Mean no load running torque ^{b)} (at $n_1=3000$ rpm and 20 °C gearbox temperature)	T_{012}	Nm	1.7	1.4	1.2	1.2	1.1	1	0.93	0.88	0.88	0.87	0.81	0.77	0.75	0.72	0.68		
		in.lb	15	12	11	11	9.7	8.9	8.2	7.8	7.8	7.7	7.2	6.8	6.6	6.4	6		
Max. backlash	j_l	arcmin	≤ 10																
Torsional rigidity ^{b)}	C_{t21}	Nm/arcmin	25	25	25	25	25	25	25	25	25	25	25	25	22	25	22		
		in.lb/arcmin	221	221	221	221	221	221	221	221	221	221	221	221	195	221	195		
Max. axial force ^{c)}	F_{2AMax}	N	5650																
		lb _f	1271																
Max. lateral force ^{c)}	F_{2QMMax}	N	6600																
		lb _f	1485																
Max. tilting moment	M_{2KMMax}	Nm	487																
		in.lb	4310																
Efficiency at full load	η	%	95																
Service life	L_n	h	> 20000																
Weight (incl. standard adapter plate)	m	kg	8.8																
		lb _m	19																
Operating noise (at reference ratio and reference speed – ratio-specific values available in cymex [®])	L_{PA}	dB(A)	≤ 61																
Max. permitted housing temperature		°C	+90																
		°F	+194																
Ambient temperature		°C	-15 to +40																
		°F	+5 to +104																
Lubrication			Lubricated for life																
Direction of rotation			In- and output same direction																
Protection class			IP 65																
Elastomer coupling (recommended product type – validate sizing with cymex [®])			ELC-0150BA032.000-X																
Bore diameter of coupling on the application side		mm	X = 019.000 - 036.000																
Mass moment of inertia (relates to the drive) Clamping hub diameter [mm]	C	14	J_1	kgcm ²	0.6	0.59	0.6	0.43	0.42	0.36	0.37	0.52	0.38	0.32	0.36	0.31	0.26	0.27	0.24
				10 ⁻³ in.lb.s ²	0.53	0.52	0.53	0.38	0.37	0.32	0.33	0.46	0.34	0.28	0.32	0.27	0.23	0.24	0.21
	D	16	J_1	kgcm ²	0.75	0.74	0.74	0.58	0.57	0.5	0.5	0.67	0.52	0.45	0.51	0.46	0.4	0.41	0.39
				10 ⁻³ in.lb.s ²	0.66	0.65	0.65	0.51	0.5	0.44	0.44	0.59	0.46	0.4	0.45	0.41	0.35	0.36	0.35
	E	19	J_1	kgcm ²	0.84	0.83	0.83	0.66	0.65	0.59	0.6	0.75	0.61	0.55	0.6	0.54	0.49	0.5	0.48
				10 ⁻³ in.lb.s ²	0.74	0.73	0.73	0.58	0.58	0.52	0.53	0.66	0.54	0.49	0.53	0.48	0.43	0.44	0.42
	G	24	J_1	kgcm ²	1.9	1.9	1.9	1.7	1.7	1.6	1.6	1.8	1.6	1.6	1.6	1.6	1.5	1.5	1.5
				10 ⁻³ in.lb.s ²	1.7	1.6	1.7	1.5	1.5	1.4	1.5	1.6	1.5	1.4	1.4	1.4	1.4	1.3	1.4
	H	28	J_1	kgcm ²	1.6	1.6	1.6	1.4	1.4	1.3	1.3	1.5	1.4	1.3	1.3	1.3	1.2	1.2	1.2
				10 ⁻³ in.lb.s ²	1.4	1.4	1.4	1.2	1.2	1.2	1.2	1.3	1.2	1.1	1.2	1.1	1.1	1.1	1.1

Please use our sizing software cymex[®] for a detailed sizing – www.wittenstein-cymex.com

^{a)} Valid for torque transmission only

^{b)} Valid for standard clamping hub diameter

^{c)} Refers to center of the output shaft or flange

^{d)} Please reduce input speed at higher ambient temperatures

^{e)} Valid for: Smooth shaft

2-stage

Motor shaft diameter [mm]

up to 19⁴⁾ (E)⁵⁾
clamping hub diameter

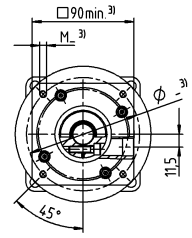
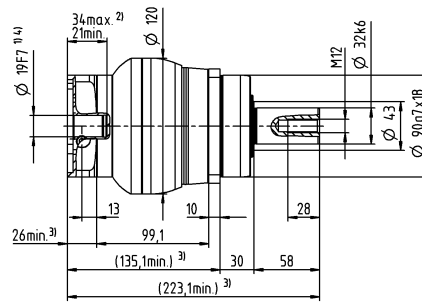
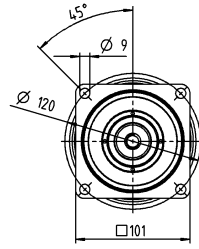

up to 28⁴⁾ (H)
clamping hub diameter

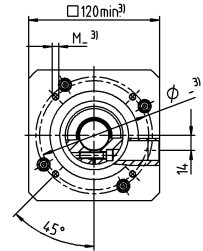
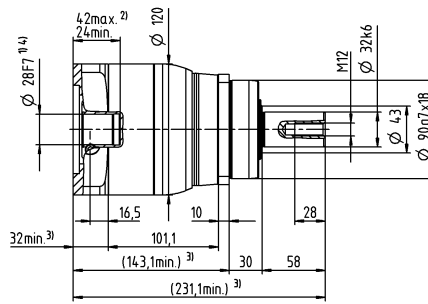
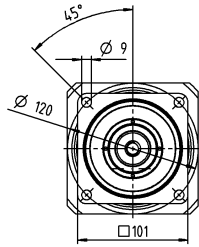

Other output variants

Shaft with key

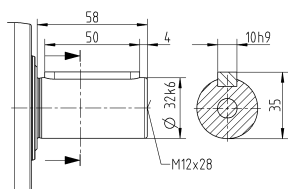

Splined shaft (DIN 5480)

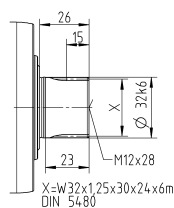

Non-tolerated dimensions are nominal dimensions

¹⁾ Check motor shaft fit

²⁾ Min. / Max. permissible motor shaft length

Longer motor shafts are possible, please contact alpha

³⁾ The dimensions depend on the motor

⁴⁾ Smaller motor shaft diameter is compensated by a bushing with a minimum wall thickness of 1 mm

⁵⁾ Standard clamping hub diameter

NPS 045 MF 1-/2-stage

			1-stage			2-stage						
Ratio	i		5	8	10	25	32	50	64	100		
Max. torque ^{a) b) e)}	T_{2a}	Nm	800	640	640	700	640	700	640	640		
		in.lb	7081	5665	5665	6196	5665	6196	5665	5665		
Max. acceleration torque ^{e)} (max. 1000 cycles per hour)	T_{2B}	Nm	500	400	400	500	400	500	400	400		
		in.lb	4425	3540	3540	4425	3540	4425	3540	3540		
Emergency stop torque ^{a) b) e)} (permitted 1000 times during the service life of the gearbox)	T_{2Not}	Nm	1000	1000	1000	1000	1000	1000	1000	1000		
		in.lb	8851	8851	8851	8851	8851	8851	8851	8851		
Permitted average input speed ^{d)} (at T_{2a} and 20 °C ambient temperature)	n_{1N}	rpm	1800	1900	2000	2600	2500	3000	2900	3000		
Max. input speed	n_{1Max}	rpm	4000	4000	4000	6000	6000	6000	6000	6000		
Mean no load running torque ^{b)} (at $n_1=3000$ rpm and 20 °C gearbox temperature)	T_{012}	Nm	4.2	3	2.6	1.6	1.5	1.2	1.1	0.97		
		in.lb	37	27	23	14	13	11	9.7	8.6		
Max. backlash	j_l	arcmin	≤ 8			≤ 10						
Torsional rigidity ^{b)}	C_{i21}	Nm/arcmin	55	44	44	55	44	55	44	44		
		in.lb/arcmin	487	389	389	487	389	487	389	389		
Max. axial force ^{c)}	F_{2AMax}	N	9870			9870						
		lb _f	2221			2221						
Max. lateral force ^{c)}	F_{2QMMax}	N	9900			9900						
		lb _f	2228			2228						
Max. tilting moment	M_{2KMMax}	Nm	952			952						
		in.lb	8426			8426						
Efficiency at full load	η	%	97			95						
Service life	L_n	h	> 20000			> 20000						
Weight (incl. standard adapter plate)	m	kg	19			19						
		lb _m	42			42						
Operating noise (at reference ratio and reference speed – ratio-specific values available in cymex [®])	L_{PA}	dB(A)	≤ 68			≤ 65						
Max. permitted housing temperature		°C	+90			+90						
		°F	+194			+194						
Ambient temperature		°C	-15 to +40			-15 to +40						
		°F	+5 to +104			+5 to +104						
Lubrication			Lubricated for life									
Direction of rotation			In- and output same direction									
Protection class			IP 65									
Elastomer coupling (recommended product type – validate sizing with cymex [®])			ELC-0300BA040.000-X									
Bore diameter of coupling on the application side		mm	X = 020.000 - 045.000									
Mass moment of inertia (relates to the drive) Clamping hub diameter [mm]	E	19	J_1	kgcm ²	-	-	-	1.2	1.1	1	0.88	0.82
				10 ⁻³ in.lb.s ²	-	-	-	1.1	0.97	0.89	0.78	0.73
	G	24	J_1	kgcm ²	-	-	-	2	1.9	1.8	1.7	1.6
				10 ⁻³ in.lb.s ²	-	-	-	1.8	1.7	1.6	1.5	1.4
	H	28	J_1	kgcm ²	-	-	-	1.7	1.6	1.5	1.4	1.3
				10 ⁻³ in.lb.s ²	-	-	-	1.5	1.4	1.3	1.2	1.2
	I	32	J_1	kgcm ²	-	-	-	5.8	5.7	5.6	5.4	5.4
				10 ⁻³ in.lb.s ²	-	-	-	5.1	5	5	4.8	4.8
	K	38	J_1	kgcm ²	8.7	7.3	7.2	7	6.9	6.8	6.6	6.5
				10 ⁻³ in.lb.s ²	7.7	6.5	6.4	6.2	6.1	6	5.8	5.8

Please use our sizing software cymex[®] for a detailed sizing – www.wittenstein-cymex.com

^{a)} Valid for torque transmission only

^{b)} Valid for standard clamping hub diameter

^{c)} Refers to center of the output shaft or flange

^{d)} Please reduce input speed at higher ambient temperatures

^{e)} Valid for: Smooth shaft

1-stage

up to 38⁴⁾ (K)⁵⁾
clamping hub
diameter

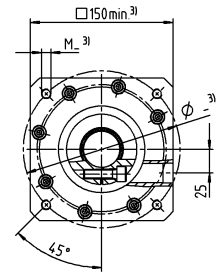
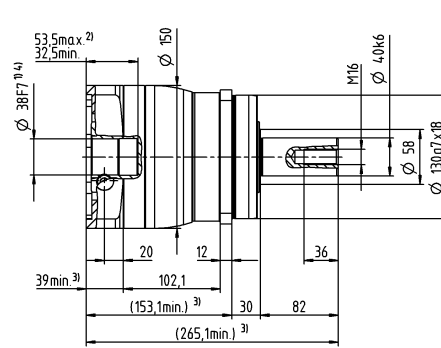
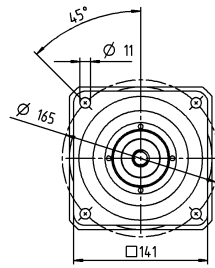

2-stage

up to 28⁴⁾ (H)⁵⁾
clamping hub
diameter

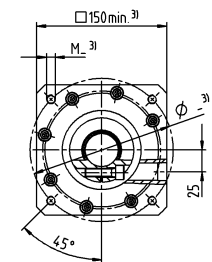
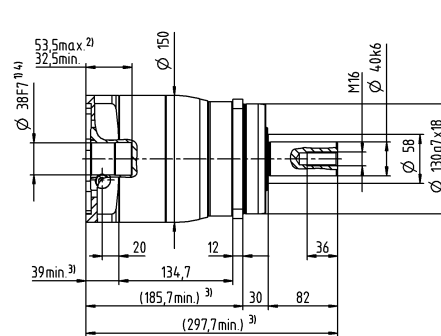
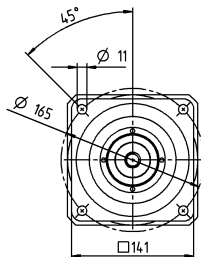
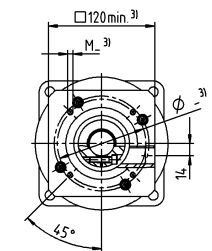
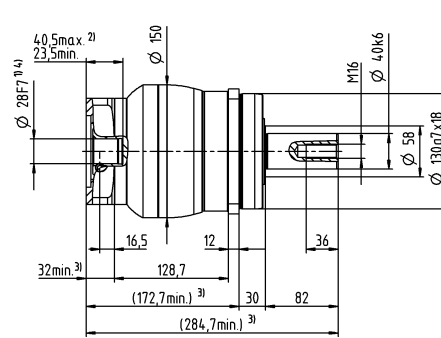
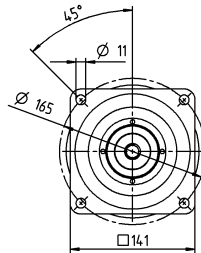

Motor shaft diameter [mm]

up to 38⁴⁾ (K)
clamping hub
diameter

Planetary Gearboxes
Value Line

Other output variants

Shaft with key

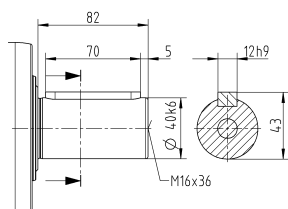

Splined shaft (DIN 5480)

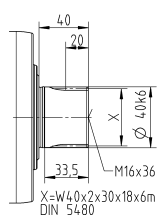

Non-tolerated dimensions are nominal dimensions

¹⁾ Check motor shaft fit

²⁾ Min. / Max. permissible motor shaft length

Longer motor shafts are possible, please contact alpha

³⁾ The dimensions depend on the motor

⁴⁾ Smaller motor shaft diameter is compensated

by a bushing with a minimum wall thickness of 1 mm

⁵⁾ Standard clamping hub diameter

NPS 015 MA 1-/2-stage

			1-stage		2-stage							
Ratio	i		3	4	12	15	16	20	28	30	40	
Max. torque ^{a) b) e)}	T_{2a}	Nm	80	67	62	67	67	67	67	62	67	
		in.lb	708	593	549	593	593	593	593	593	549	593
Max. acceleration torque ^{e)} (max. 1000 cycles per hour)	T_{2B}	Nm	55	42	39	42	42	42	42	42	39	42
		in.lb	487	372	345	372	372	372	372	372	345	372
Emergency stop torque ^{a) b) e)} (permitted 1000 times during the service life of the gearbox)	T_{2Not}	Nm	80	80	80	80	80	80	80	80	80	80
		in.lb	708	708	708	708	708	708	708	708	708	708
Permitted average input speed ^{d)} (at T_{2m} and 20 °C ambient temperature)	n_{1N}	rpm	2900	3100	3800	4000	3800	4000	4300	4600	4600	
Max. input speed	n_{1Max}	rpm	8000	8000	10000	10000	10000	10000	10000	10000	10000	
Mean no load running torque ^{b)} (at $n_1=3000$ rpm and 20 °C gearbox temperature)	T_{012}	Nm	0.92	0.74	0.34	0.29	0.29	0.25	0.21	0.21	0.19	
		in.lb	8.1	6.5	3	2.6	2.6	2.2	1.9	1.9	1.7	
Max. backlash	j_l	arcmin	≤ 8		≤ 10							
Torsional rigidity ^{b)}	C_{i21}	Nm/arcmin	4	4	4	4	4	4	4	4	4	
		in.lb/arcmin	35	35	35	35	35	35	35	35	35	
Max. axial force ^{c)}	F_{2AMax}	N	2400		2400							
		lb _f	540		540							
Max. lateral force ^{c)}	F_{2QMMax}	N	2800		2800							
		lb _f	630		630							
Max. tilting moment	M_{2KMMax}	Nm	152		152							
		in.lb	1345		1345							
Efficiency at full load	η	%	97		95							
Service life	L_n	h	> 20000		> 20000							
Weight (incl. standard adapter plate)	m	kg	1.8		1.9							
		lb _m	4		4.2							
Operating noise (at reference ratio and reference speed – ratio-specific values available in cymex®)	L_{PA}	dB(A)	≤ 59		≤ 58							
Max. permitted housing temperature		°C	+90		+90							
		°F	+194		+194							
Ambient temperature		°C	-15 to +40		-15 to +40							
		°F	+5 to +104		+5 to +104							
Lubrication			Lubricated for life									
Direction of rotation			In- and output same direction									
Protection class			IP 65									
Elastomer coupling (recommended product type – validate sizing with cymex®)			ELC-0060BA016.000-X									
Bore diameter of coupling on the application side		mm	X = 012.000 - 032.000									
Mass moment of inertia (relates to the drive) Clamping hub diameter [mm]	Z	8	J_1	kgcm ²	-	-	0.04	0.04	0.03	0.03	0.03	0.03
				10 ⁻³ in.lb.s ²	-	-	0.04	0.04	0.03	0.03	0.03	0.03
	A	9	J_1	kgcm ²	0.25	0.19	0.04	0.04	0.03	0.03	0.03	0.03
				10 ⁻³ in.lb.s ²	0.22	0.17	0.04	0.04	0.03	0.03	0.03	0.03
	B	11	J_1	kgcm ²	0.26	0.21	0.06	0.06	0.05	0.05	0.05	0.05
				10 ⁻³ in.lb.s ²	0.23	0.19	0.05	0.05	0.04	0.04	0.04	0.04
	C	14	J_1	kgcm ²	0.34	0.28	0.14	0.14	0.14	0.13	0.13	0.14
				10 ⁻³ in.lb.s ²	0.3	0.25	0.12	0.12	0.12	0.12	0.12	0.12
	D	16	J_1	kgcm ²	0.47	0.41	-	-	-	-	-	-
				10 ⁻³ in.lb.s ²	0.42	0.36	-	-	-	-	-	-
	E	19	J_1	kgcm ²	0.55	0.49	-	-	-	-	-	-
				10 ⁻³ in.lb.s ²	0.49	0.43	-	-	-	-	-	-

Please use our sizing software cymex® for a detailed sizing – www.wittenstein-cymex.com

^{a)} Valid for torque transmission only

^{b)} Valid for standard clamping hub diameter

^{c)} Refers to center of the output shaft or flange

^{d)} Please reduce input speed at higher ambient temperatures

^{e)} Valid for: Smooth shaft

1-stage

up to 14⁴⁾ (C)⁵⁾
clamping hub diameter

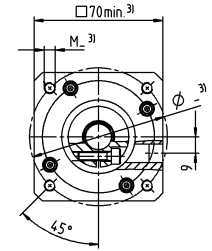
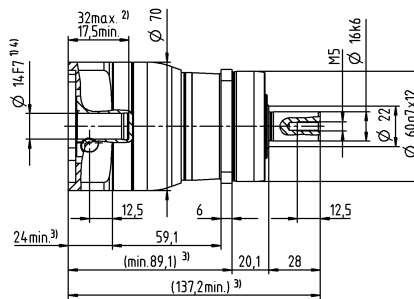
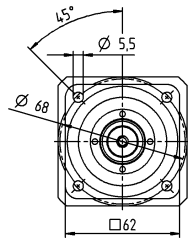

up to 19⁴⁾ (E)
clamping hub diameter

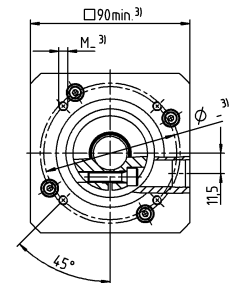
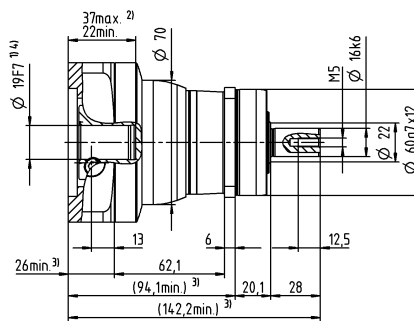
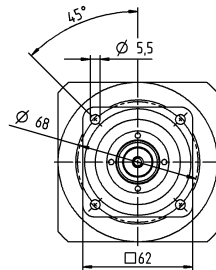

2-stage

up to 11⁴⁾ (B)⁵⁾
clamping hub diameter

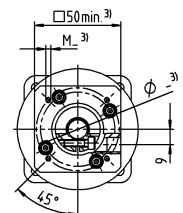
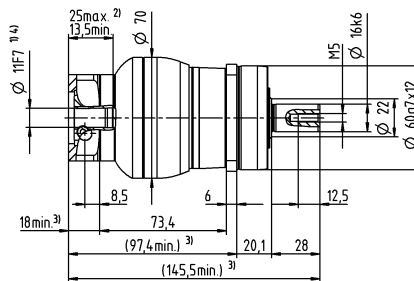
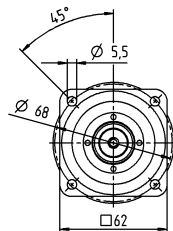

up to 14⁴⁾ (C)
clamping hub diameter

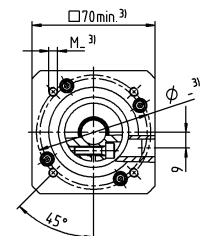
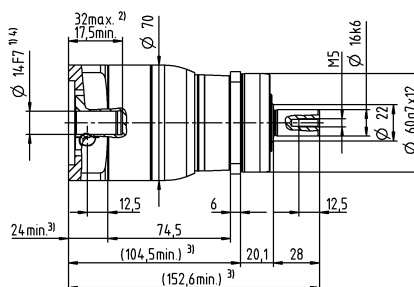
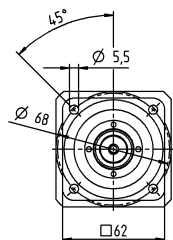

Motor shaft diameter [mm]

Other output variants

Shaft with key

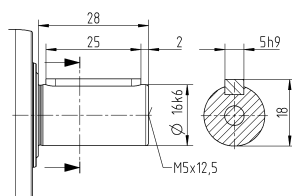

Splined shaft (DIN 5480)

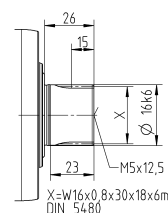

Non-tolerated dimensions are nominal dimensions

¹⁾ Check motor shaft fit

²⁾ Min. / Max. permissible motor shaft length

Longer motor shafts are possible, please contact alpha

³⁾ The dimensions depend on the motor

⁴⁾ Smaller motor shaft diameter is compensated by a bushing with a minimum wall thickness of 1 mm

⁵⁾ Standard clamping hub diameter

NPS 025 MA 1-/2-stage

			1-stage		2-stage									
Ratio	i		3	4	9	12	15	16	20	28	30	40		
Max. torque ^{a) b) e)}	T_{2a}	Nm	185	185	185	185	185	185	185	185	168	185		
		in.lb	1637	1637	1637	1637	1637	1637	1637	1637	1637	1487	1637	
Max. acceleration torque ^{e)} (max. 1000 cycles per hour)	T_{2B}	Nm	125	115	125	125	120	115	115	115	105	115		
		in.lb	1106	1018	1106	1106	1062	1018	1018	1018	929	1018		
Emergency stop torque ^{a) b) e)} (permitted 1000 times during the service life of the gearbox)	T_{2Not}	Nm	190	190	190	190	190	190	190	190	190	190		
		in.lb	1682	1682	1682	1682	1682	1682	1682	1682	1682	1682		
Permitted average input speed ^{d)} (at T_{2a} and 20 °C ambient temperature)	n_{1N}	rpm	2700	2900	2900	3500	3700	3500	3700	4000	4300	4300		
Max. input speed	n_{1Max}	rpm	7000	7000	8000	8000	8000	8000	8000	8000	8000	8000		
Mean no load running torque ^{b)} (at $n_1=3000$ rpm and 20 °C gearbox temperature)	T_{012}	Nm	1.8	1.5	0.67	0.55	0.47	0.46	0.4	0.34	0.33	0.29		
		in.lb	16	13	5.9	4.9	4.2	4.1	3.5	3	2.9	2.6		
Max. backlash	j_l	arcmin	≤ 8		≤ 10									
Torsional rigidity ^{b)}	C_{i21}	Nm/arcmin	12	12	12	12	12	12	12	12	12	12		
		in.lb/arcmin	106	106	106	106	106	106	106	106	106	106		
Max. axial force ^{c)}	F_{2AMax}	N	3350				3350							
		lb _f	754				754							
Max. lateral force ^{c)}	F_{2QMMax}	N	4200				4200							
		lb _f	945				945							
Max. tilting moment	M_{2KMMax}	Nm	236				236							
		in.lb	2089				2089							
Efficiency at full load	η	%	97				95							
Service life	L_n	h	> 20000				> 20000							
Weight (incl. standard adapter plate)	m	kg	3.6				3.9							
		lb _m	8				8.6							
Operating noise (at reference ratio and reference speed – ratio-specific values available in cymex®)	L_{PA}	dB(A)	≤ 61				≤ 59							
			°C				°C							
Max. permitted housing temperature			+90				+90							
			°F				°F							
Ambient temperature			-15 to +40				-15 to +40							
			°F				°F							
Lubrication		Lubricated for life												
Direction of rotation		In- and output same direction												
Protection class		IP 65												
Elastomer coupling (recommended product type – validate sizing with cymex®)		ELC-0060BA022.000-X												
Bore diameter of coupling on the application side		mm	X = 012.000 - 032.000											
Mass moment of inertia (relates to the drive) Clamping hub diameter [mm]	A	9	J_1	kgcm ²	-	-	0.26	0.22	0.21	0.21	0.2	0.19	0.19	0.19
				10 ⁻³ in.lb.s ²	-	-	0.23	0.19	0.19	0.19	0.18	0.17	0.17	0.17
	B	11	J_1	kgcm ²	-	-	0.28	0.24	0.23	0.23	0.22	0.21	0.21	0.21
				10 ⁻³ in.lb.s ²	-	-	0.25	0.21	0.2	0.2	0.19	0.19	0.19	0.19
	C	14	J_1	kgcm ²	0.58	0.47	0.35	0.31	0.3	0.3	0.3	0.29	0.28	0.28
				10 ⁻³ in.lb.s ²	0.51	0.42	0.31	0.27	0.27	0.27	0.27	0.26	0.25	0.25
	D	16	J_1	kgcm ²	0.73	0.62	0.48	0.44	0.43	0.43	0.42	0.41	0.41	0.41
				10 ⁻³ in.lb.s ²	0.65	0.55	0.42	0.39	0.38	0.38	0.37	0.36	0.36	0.36
	E	19	J_1	kgcm ²	0.81	0.71	0.56	0.52	0.51	0.52	0.51	0.5	0.5	0.49
				10 ⁻³ in.lb.s ²	0.72	0.63	0.5	0.46	0.45	0.46	0.45	0.44	0.44	0.43
	G	24	J_1	kgcm ²	1.8	1.7	-	-	-	-	-	-	-	-
				10 ⁻³ in.lb.s ²	1.6	1.5	-	-	-	-	-	-	-	-
	H	28	J_1	kgcm ²	1.6	1.4	-	-	-	-	-	-	-	-
				10 ⁻³ in.lb.s ²	1.4	1.2	-	-	-	-	-	-	-	-

Please use our sizing software cymex® for a detailed sizing – www.wittenstein-cymex.com

^{a)} Valid for torque transmission only

^{b)} Valid for standard clamping hub diameter

^{c)} Refers to center of the output shaft or flange

^{d)} Please reduce input speed at higher ambient temperatures

^{e)} Valid for: Smooth shaft

1-stage

up to 19⁴⁾ (E)⁵⁾
clamping hub diameter

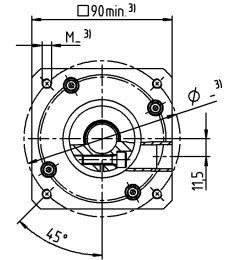
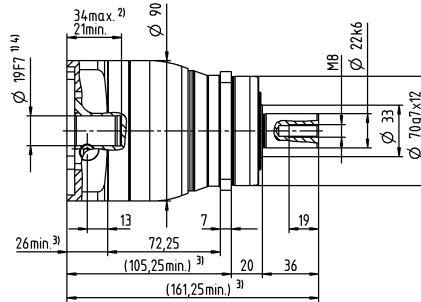
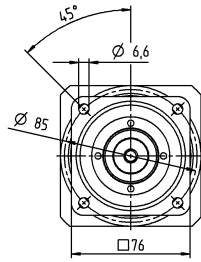

up to 28⁴⁾ (H)
clamping hub diameter

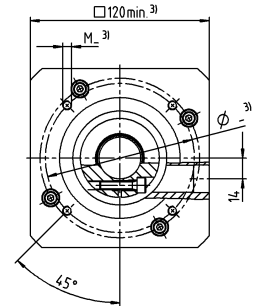
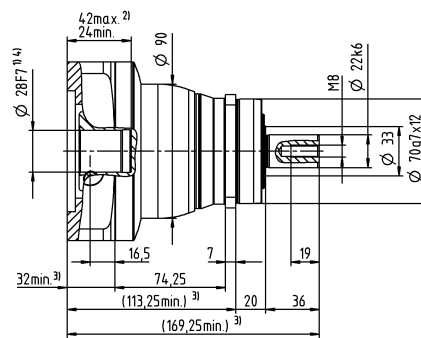
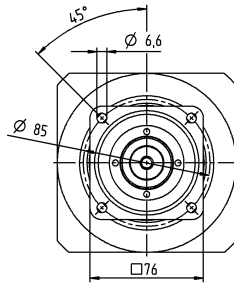

2-stage

up to 14⁴⁾ (C)⁵⁾
clamping hub diameter

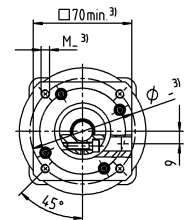
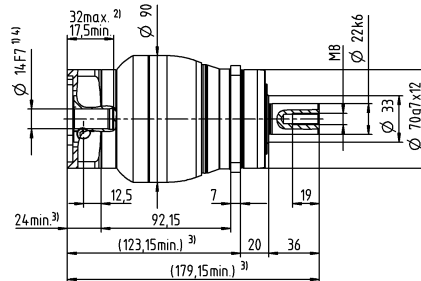
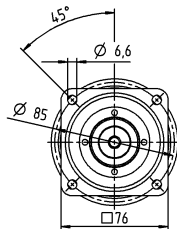

up to 19⁴⁾ (E)
clamping hub diameter

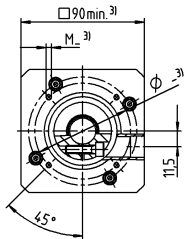
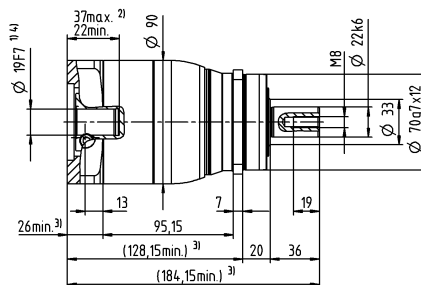
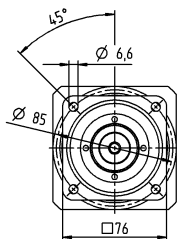

Motor shaft diameter [mm]

Other output variants

Shaft with key

Splined shaft (DIN 5480)

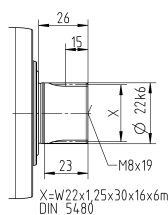
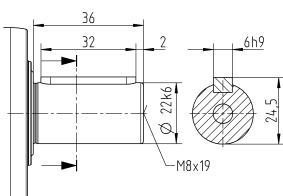

Non-tolerated dimensions are nominal dimensions

¹⁾ Check motor shaft fit

²⁾ Min. / Max. permissible motor shaft length

Longer motor shafts are possible, please contact alpha

³⁾ The dimensions depend on the motor

⁴⁾ Smaller motor shaft diameter is compensated

by a bushing with a minimum wall thickness of 1 mm

⁵⁾ Standard clamping hub diameter

NPS 035 MA 1-/2-stage

			1-stage		2-stage									
Ratio	i		3	4	9	12	15	16	20	28	30	40		
Max. torque ^{a) b) e)}	T_{2a}	Nm	480	480	480	480	480	480	480	480	432	480		
		in.lb	4248	4248	4248	4248	4248	4248	4248	4248	4248	3824	4248	
Max. acceleration torque ^{e)} (max. 1000 cycles per hour)	T_{2B}	Nm	305	305	305	305	300	305	305	305	270	305		
		in.lb	2699	2699	2699	2699	2655	2699	2699	2699	2390	2699		
Emergency stop torque ^{a) b) e)} (permitted 1000 times during the service life of the gearbox)	T_{2Not}	Nm	500	500	500	500	500	500	500	500	500	500		
		in.lb	4425	4425	4425	4425	4425	4425	4425	4425	4425	4425		
Permitted average input speed ^{d)} (at T_{2N} and 20 °C ambient temperature)	n_{1N}	rpm	2000	2200	2700	3300	3400	3300	3400	3600	3900	3900		
Max. input speed	n_{1Max}	rpm	6000	6000	7000	7000	7000	7000	7000	7000	7000	7000		
Mean no load running torque ^{b)} (at $n_1=3000$ rpm and 20 °C gearbox temperature)	T_{012}	Nm	3.3	2.7	1.7	1.4	1.2	1.2	1.1	0.93	0.88	0.81		
		in.lb	29	24	15	12	11	11	9.7	8.2	7.8	7.2		
Max. backlash	j_l	arcmin	≤ 8		≤ 10									
Torsional rigidity ^{b)}	C_{i21}	Nm/arcmin	30	30	30	30	30	30	30	30	30	30		
		in.lb/arcmin	266	266	266	266	266	266	266	266	266	266		
Max. axial force ^{c)}	F_{2AMax}	N	5650		5650									
		lb _f	1271		1271									
Max. lateral force ^{c)}	F_{2QMMax}	N	6600		6600									
		lb _f	1485		1485									
Max. tilting moment	M_{2KMMax}	Nm	487		487									
		in.lb	4310		4310									
Efficiency at full load	η	%	97		95									
Service life	L_n	h	> 20000		> 20000									
Weight (incl. standard adapter plate)	m	kg	8.4		8.8									
		lb _m	19		19									
Operating noise (at reference ratio and reference speed – ratio-specific values available in cymex®)	L_{PA}	dB(A)	≤ 65		≤ 61									
		°C	+90		+90									
Max. permitted housing temperature		°F	+194		+194									
		°C	-15 to +40		-15 to +40									
Ambient temperature		°F	+5 to +104		+5 to +104									
			Lubricated for life											
Direction of rotation			In- and output same direction											
Protection class			IP 65											
Elastomer coupling (recommended product type – validate sizing with cymex®)			ELC-0150BA032.000-X											
Bore diameter of coupling on the application side		mm	X = 019.000 - 036.000											
Mass moment of inertia (relates to the drive) Clamping hub diameter [mm]	C	14	J_1	kgcm ²	-	-	0.6	0.59	0.6	0.43	0.42	0.37	0.52	0.36
				10 ⁻³ in.lb.s ²	-	-	0.53	0.52	0.53	0.38	0.37	0.33	0.46	0.32
	D	16	J_1	kgcm ²	-	-	0.75	0.74	0.74	0.58	0.57	0.5	0.67	0.51
				10 ⁻³ in.lb.s ²	-	-	0.66	0.65	0.65	0.51	0.5	0.44	0.59	0.45
	E	19	J_1	kgcm ²	2.5	1.7	0.84	0.83	0.83	0.66	0.65	0.6	0.75	0.6
				10 ⁻³ in.lb.s ²	2.2	1.5	0.74	0.73	0.73	0.58	0.58	0.53	0.66	0.53
	G	24	J_1	kgcm ²	3.3	2.4	1.9	1.9	1.9	1.7	1.7	1.6	1.8	1.6
				10 ⁻³ in.lb.s ²	2.9	2.1	1.7	1.6	1.7	1.5	1.5	1.5	1.6	1.4
	H	28	J_1	kgcm ²	3	2.2	1.6	1.6	1.6	1.4	1.4	1.3	1.5	1.3
				10 ⁻³ in.lb.s ²	2.7	1.9	1.4	1.4	1.4	1.2	1.2	1.2	1.3	1.2
	I	32	J_1	kgcm ²	7.1	6.2	-	-	-	-	-	-	-	-
				10 ⁻³ in.lb.s ²	6.3	5.5	-	-	-	-	-	-	-	-
K	38	J_1	kgcm ²	8.3	7.4	-	-	-	-	-	-	-	-	
			10 ⁻³ in.lb.s ²	7.3	6.5	-	-	-	-	-	-	-	-	

Please use our sizing software cymex® for a detailed sizing – www.wittenstein-cymex.com

^{a)} Valid for torque transmission only

^{b)} Valid for standard clamping hub diameter

^{c)} Refers to center of the output shaft or flange

^{d)} Please reduce input speed at higher ambient temperatures

^{e)} Valid for: Smooth shaft

1-stage

up to 24⁴⁾ (G⁵⁾/H)
clamping hub diameter

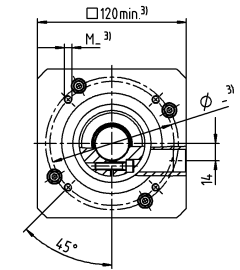
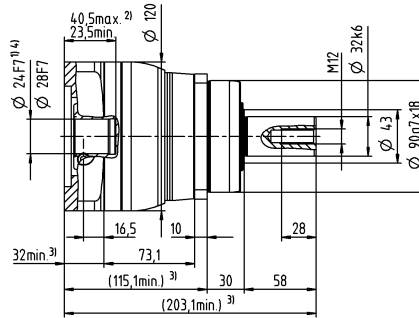
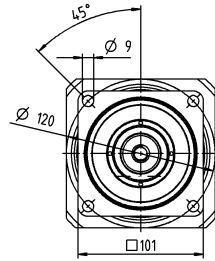

up to 38⁴⁾ (K)
clamping hub diameter

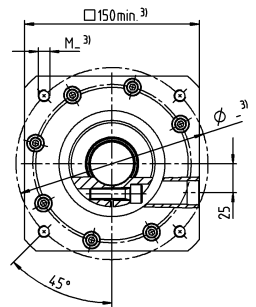
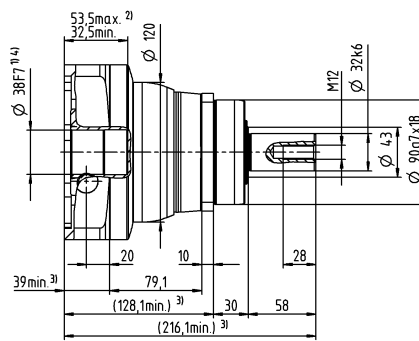
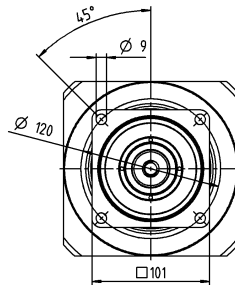

2-stage

up to 19⁴⁾ (E)⁵⁾
clamping hub diameter

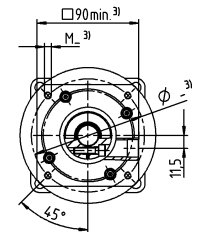
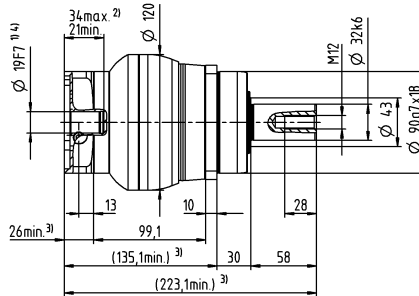
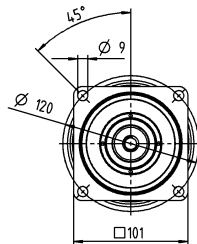

up to 28⁴⁾ (H)
clamping hub diameter

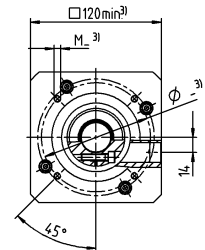
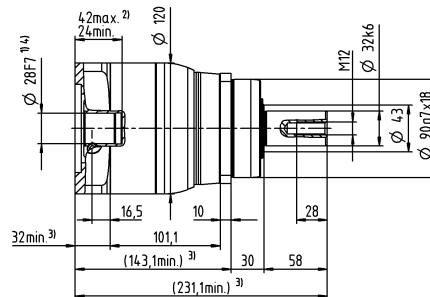
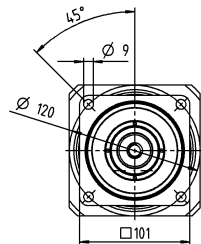

Motor shaft diameter [mm]

Other output variants

Shaft with key

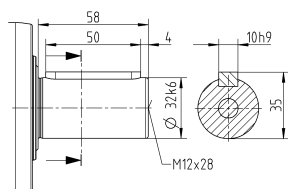

Splined shaft (DIN 5480)

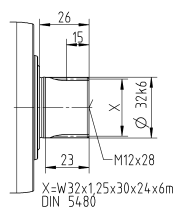

Non-tolerated dimensions are nominal dimensions

¹⁾ Check motor shaft fit

²⁾ Min. / Max. permissible motor shaft length

Longer motor shafts are possible, please contact alpha

³⁾ The dimensions depend on the motor

⁴⁾ Smaller motor shaft diameter is compensated

by a bushing with a minimum wall thickness of 1 mm

⁵⁾ Standard clamping hub diameter

NPT 005 MF 1-stage

			1-stage						
Ratio	i		4	5	7	8	10		
Max. torque ^{a) b)}	T_{2a}	Nm	18	22	22	21	21		
		in.lb	159	195	195	186	186		
Max. acceleration torque (max. 1000 cycles per hour)	T_{2B}	Nm	11	14	14	13	13		
		in.lb	97	124	124	115	115		
Emergency stop torque ^{a) b)} (permitted 1000 times during the service life of the gearbox)	T_{2Not}	Nm	26	26	26	26	26		
		in.lb	230	230	230	230	230		
Permitted average input speed ^{d)} (at T_{2a} and 20 °C ambient temperature)	n_{1N}	rpm	3800	4000	4300	4400	4600		
Max. input speed	n_{1Max}	rpm	10000	10000	10000	10000	10000		
Mean no load running torque ^{b)} (at $n_1=3000$ rpm and 20 °C gearbox temperature)	T_{012}	Nm	0.08	0.07	0.05	0.05	0.05		
		in.lb	0.71	0.62	0.44	0.44	0.44		
Max. backlash	j_t	arcmin	≤ 10						
Torsional rigidity ^{b)}	C_{t21}	Nm/arcmin	1.2	1.2	1.2	0.85	0.85		
		in.lb/arcmin	11	11	11	7.5	7.5		
Max. axial force ^{c)}	F_{2AMax}	N	600						
		lb _f	135						
Max. tilting moment	M_{2KMax}	Nm	17						
		in.lb	150						
Efficiency at full load	η	%	97						
Service life	L_n	h	> 20000						
Weight (incl. standard adapter plate)	m	kg	0.9						
		lb _m	2						
Operating noise (at reference ratio and reference speed – ratio-specific values available in cymex [®])	L_{PA}	dB(A)	≤ 58						
Max. permitted housing temperature		°C	+90						
		°F	+194						
Ambient temperature		°C	-15 to +40						
		°F	+5 to +104						
Lubrication			Lubricated for life						
Direction of rotation			In- and output same direction						
Protection class			IP 64						
Elastomer coupling (recommended product type – validate sizing with cymex [®])			ELT-00020BAX-025.00						
Bore diameter of coupling on the application side		mm	X = 008.000 - 025.000						
Mass moment of inertia (relates to the drive) Clamping hub diameter [mm]	Z	8	J_1	kgcm ²	0.04	0.03	0.03	0.03	0.02
				10 ⁻³ in.lb.s ²	0.04	0.03	0.03	0.03	0.02
	A	9	J_1	kgcm ²	0.04	0.03	0.03	0.03	0.02
				10 ⁻³ in.lb.s ²	0.04	0.03	0.03	0.03	0.02
	B	11	J_1	kgcm ²	0.06	0.05	0.05	0.04	0.04
				10 ⁻³ in.lb.s ²	0.05	0.04	0.04	0.04	0.04
	C	14	J_1	kgcm ²	0.14	0.14	0.13	0.13	0.13
				10 ⁻³ in.lb.s ²	0.12	0.12	0.12	0.12	0.12

Please use our sizing software cymex[®] for a detailed sizing – www.wittenstein-cymex.com

^{a)} Valid for torque transmission only

^{b)} Valid for standard clamping hub diameter

^{c)} Refers to center of the output shaft or flange

^{d)} Please reduce input speed at higher ambient temperatures

1-stage

up to 11⁴⁾ (B)⁵⁾
clamping hub
diameter

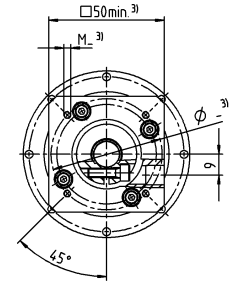
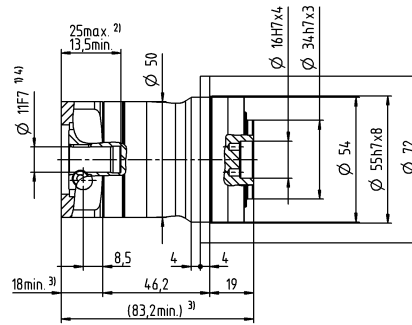
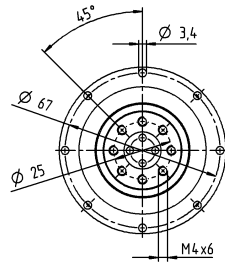

Motor shaft diameter [mm]

up to 14⁴⁾ (C)
clamping hub
diameter

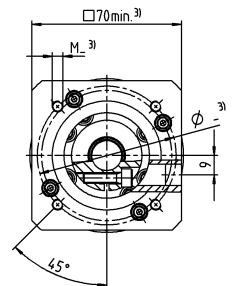
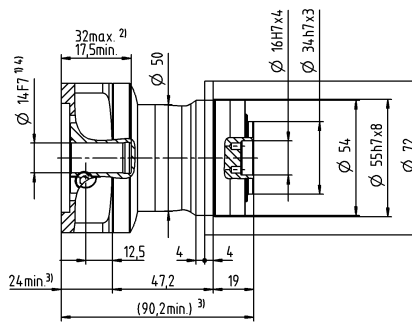
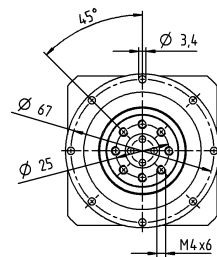

Non-tolerated dimensions are nominal dimensions

¹⁾ Check motor shaft fit

²⁾ Min. / Max. permissible motor shaft length

Longer motor shafts are possible, please contact alpha

³⁾ The dimensions depend on the motor

⁴⁾ Smaller motor shaft diameter is compensated by a bushing with a minimum wall thickness of 1 mm

⁵⁾ Standard clamping hub diameter

NPT 005 MF 2-stage

			2-stage											
Ratio	i		16	20	25	28	35	40	50	64	70	100		
Max. torque ^{a) b)}	T_{2a}	Nm	18	18	22	18	22	18	22	21	22	21		
		in.lb	159	159	195	159	195	159	195	186	195	186		
Max. acceleration torque (max. 1000 cycles per hour)	T_{2B}	Nm	11	11	14	11	14	11	14	13	14	13		
		in.lb	97	97	124	97	124	97	124	115	124	115		
Emergency stop torque ^{a) b)} (permitted 1000 times during the service life of the gearbox)	T_{2Not}	Nm	26	26	26	26	26	26	26	26	26	26		
		in.lb	230	230	230	230	230	230	230	230	230	230		
Permitted average input speed ^{d)} (at T_{2N} and 20 °C ambient temperature)	n_{1N}	rpm	4000	4000	4000	4300	4300	4600	4600	4400	4600	4600		
Max. input speed	n_{1Max}	rpm	10000	10000	10000	10000	10000	10000	10000	10000	10000	10000		
Mean no load running torque ^{b)} (at $n_1=3000$ rpm and 20 °C gearbox temperature)	T_{012}	Nm	0.04	0.04	0.03	0.03	0.03	0.03	0.03	0.03	0.03	0.03		
		in.lb	0.35	0.35	0.27	0.27	0.27	0.27	0.27	0.27	0.27	0.27		
Max. backlash	j_t	arcmin	≤ 13											
Torsional rigidity ^{b)}	C_{t21}	Nm/arcmin	1.2	1.2	1.2	1.2	1.2	1.2	1.2	0.85	1.2	0.85		
		in.lb/arcmin	11	11	11	11	11	11	11	7.5	11	7.5		
Max. axial force ^{c)}	F_{2AMax}	N	600											
		lb _f	135											
Max. tilting moment	M_{2KMMax}	Nm	17											
		in.lb	150											
Efficiency at full load	η	%	95											
Service life	L_n	h	> 20000											
Weight (incl. standard adapter plate)	m	kg	1.1											
		lb _m	2.4											
Operating noise (at reference ratio and reference speed – ratio-specific values available in cymex®)	L_{PA}	dB(A)	≤ 58											
Max. permitted housing temperature		°C	+90											
		°F	+194											
Ambient temperature		°C	-15 to +40											
		°F	+5 to +104											
Lubrication			Lubricated for life											
Direction of rotation			In- and output same direction											
Protection class			IP 64											
Elastomer coupling (recommended product type – validate sizing with cymex®)			ELT-00020BAX-025.00											
Bore diameter of coupling on the application side		mm	X = 008.000 - 025.000											
Mass moment of inertia (relates to the drive) Clamping hub diameter [mm]	Z	8	J_1	kgcm ²	0.03	0.03	0.03	0.03	0.03	0.02	0.02	0.02	0.02	0.03
				10 ⁻³ in.lb.s ²	0.03	0.03	0.03	0.03	0.03	0.02	0.02	0.02	0.02	0.02
	A	9	J_1	kgcm ²	0.03	0.03	0.03	0.03	0.03	0.02	0.02	0.02	0.02	0.03
				10 ⁻³ in.lb.s ²	0.03	0.03	0.03	0.03	0.03	0.02	0.02	0.02	0.02	0.03
	B	11	J_1	kgcm ²	0.05	0.05	0.04	0.05	0.04	0.04	0.04	0.04	0.04	0.05
				10 ⁻³ in.lb.s ²	0.04	0.04	0.04	0.04	0.04	0.04	0.04	0.04	0.04	0.04
	C	14	J_1	kgcm ²	0.13	0.13	0.13	0.13	0.13	0.13	0.13	0.13	0.13	0.13
				10 ⁻³ in.lb.s ²	0.12	0.12	0.12	0.12	0.12	0.12	0.12	0.12	0.12	0.12

Please use our sizing software cymex® for a detailed sizing – www.wittenstein-cymex.com

^{a)} Valid for torque transmission only

^{b)} Valid for standard clamping hub diameter

^{c)} Refers to center of the output shaft or flange

^{d)} Please reduce input speed at higher ambient temperatures

2-stage

Motor shaft diameter [mm]

up to 11⁴⁾ (B)⁵⁾
clamping hub diameter

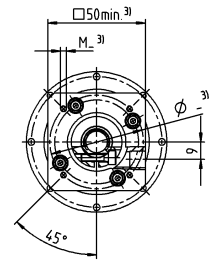
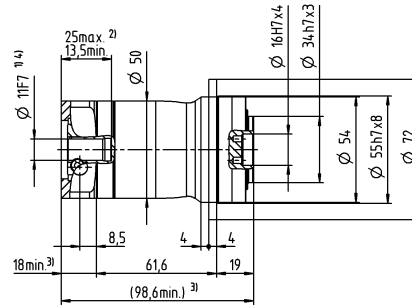
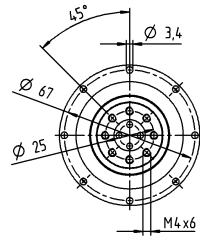

up to 14⁴⁾ (C)
clamping hub diameter

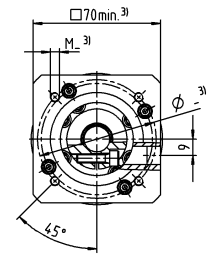
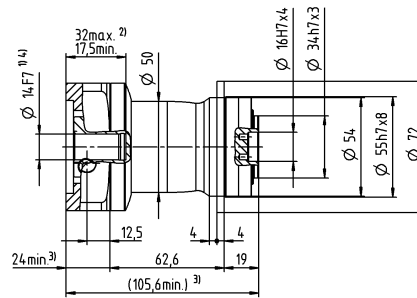
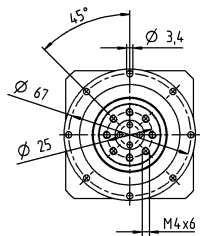

Non-tolerated dimensions are nominal dimensions

¹⁾ Check motor shaft fit

²⁾ Min. / Max. permissible motor shaft length

Longer motor shafts are possible, please contact alpha

³⁾ The dimensions depend on the motor

⁴⁾ Smaller motor shaft diameter is compensated by a bushing with a minimum wall thickness of 1 mm

⁵⁾ Standard clamping hub diameter

NPT 015 MF 1-stage

			1-stage							
Ratio	i		3	4	5	7	8	10		
Max. torque ^{a) b)}	T_{2a}	Nm	51	56	60	60	56	56		
		in.lb	451	496	531	531	496	496		
Max. acceleration torque (max. 1000 cycles per hour)	T_{2B}	Nm	32	35	40	40	35	35		
		in.lb	283	310	354	354	310	310		
Emergency stop torque ^{a) b)} (permitted 1000 times during the service life of the gearbox)	T_{2Not}	Nm	75	75	75	75	75	75		
		in.lb	664	664	664	664	664	664		
Permitted average input speed ^{d)} (at T_{2N} and 20 °C ambient temperature)	n_{1N}	rpm	3300	3500	3700	4000	4100	4300		
Max. input speed	n_{1Max}	rpm	8000	8000	8000	8000	8000	8000		
Mean no load running torque ^{b)} (at $n_1=3000$ rpm and 20 °C gearbox temperature)	T_{012}	Nm	0.25	0.2	0.17	0.14	0.13	0.11		
		in.lb	2.2	1.8	1.5	1.2	1.2	0.97		
Max. backlash	j_t	arcmin	≤ 8							
Torsional rigidity ^{b)}	C_{t21}	Nm/arcmin	3.3	3.3	3.3	3.3	2.8	2.8		
		in.lb/arcmin	29	29	29	29	25	25		
Max. axial force ^{c)}	F_{2AMax}	N	1380							
		lb _f	311							
Max. tilting moment	M_{2KMMax}	Nm	42							
		in.lb	372							
Efficiency at full load	η	%	97							
Service life	L_n	h	> 20000							
Weight (incl. standard adapter plate)	m	kg	2							
		lb _m	4.4							
Operating noise (at reference ratio and reference speed – ratio-specific values available in cymex®)	L_{PA}	dB(A)	≤ 59							
Max. permitted housing temperature		°C	+90							
		°F	+194							
Ambient temperature		°C	-15 to +40							
		°F	+5 to +104							
Lubrication			Lubricated for life							
Direction of rotation			In- and output same direction							
Protection class			IP 64							
Elastomer coupling (recommended product type – validate sizing with cymex®)			ELT-00060BAX-031.50							
Bore diameter of coupling on the application side		mm	X = 018.000 - 032.000							
Mass moment of inertia (relates to the drive) Clamping hub diameter [mm]	A	9	J_1	kgcm ²	0.31	0.23	0.19	0.16	0.15	0.14
				10 ⁻³ in.lb.s ²	0.27	0.2	0.17	0.14	0.13	0.12
	B	11	J_1	kgcm ²	0.33	0.24	0.21	0.17	0.17	0.16
				10 ⁻³ in.lb.s ²	0.29	0.21	0.19	0.15	0.15	0.14
	C	14	J_1	kgcm ²	0.41	0.32	0.28	0.25	0.24	0.23
				10 ⁻³ in.lb.s ²	0.36	0.28	0.25	0.22	0.21	0.2
	D	16	J_1	kgcm ²	0.53	0.45	0.41	0.38	0.37	0.36
				10 ⁻³ in.lb.s ²	0.47	0.4	0.36	0.34	0.33	0.32
	E	19	J_1	kgcm ²	0.62	0.53	0.49	0.46	0.45	0.44
				10 ⁻³ in.lb.s ²	0.55	0.47	0.43	0.41	0.4	0.39

Please use our sizing software cymex® for a detailed sizing – www.wittenstein-cymex.com

^{a)} Valid for torque transmission only

^{b)} Valid for standard clamping hub diameter

^{c)} Refers to center of the output shaft or flange

^{d)} Please reduce input speed at higher ambient temperatures

1-stage

Motor shaft diameter [mm]

up to 14⁴⁾ (C)⁵⁾
clamping hub diameter

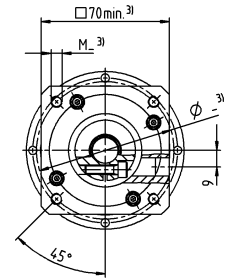
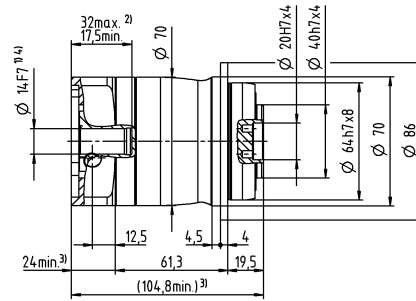
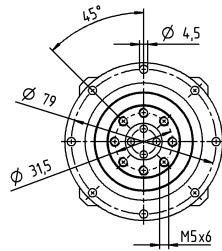

up to 19⁴⁾ (E)
clamping hub diameter

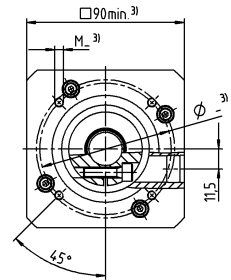
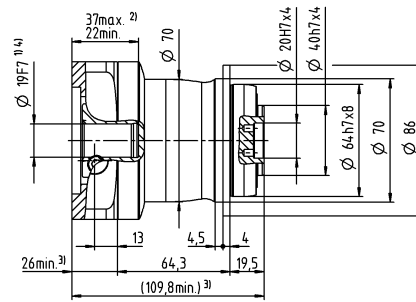
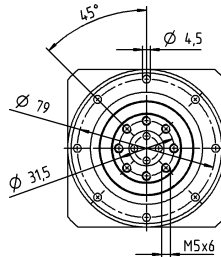

Non-tolerated dimensions are nominal dimensions

¹⁾ Check motor shaft fit

²⁾ Min. / Max. permissible motor shaft length

Longer motor shafts are possible, please contact alpha

³⁾ The dimensions depend on the motor

⁴⁾ Smaller motor shaft diameter is compensated by a bushing with a minimum wall thickness of 1 mm

⁵⁾ Standard clamping hub diameter

NPT 015 MF 2-stage

			2-stage															
Ratio	i		12	15	16	20	25	28	30	32	35	40	50	64	70	100		
Max. torque ^{a) b)}	T_{2a}	Nm	51	51	56	56	60	56	51	56	60	56	60	56	60	56		
		in.lb	451	451	496	496	531	496	451	496	531	496	531	496	531	496	531	
Max. acceleration torque (max. 1000 cycles per hour)	T_{2B}	Nm	32	32	35	35	40	35	32	35	40	35	40	35	40	35		
		in.lb	283	283	310	310	354	310	283	310	354	310	354	310	354	310		
Emergency stop torque ^{a) b)} (permitted 1000 times during the service life of the gearbox)	T_{2Not}	Nm	75	75	75	75	75	75	75	75	75	75	75	75	75	75		
		in.lb	664	664	664	664	664	664	664	664	664	664	664	664	664	664		
Permitted average input speed ^{d)} (at T_{2N} and 20 °C ambient temperature)	n_{1N}	rpm	3800	4000	3800	4000	4000	4300	4600	4400	4300	4600	4600	4400	4600	4600		
Max. input speed	n_{1Max}	rpm	10000	10000	10000	10000	10000	10000	10000	10000	10000	10000	10000	10000	10000	10000		
Mean no load running torque ^{b)} (at $n_1=3000$ rpm and 20 °C gearbox temperature)	T_{012}	Nm	0.08	0.07	0.06	0.06	0.05	0.05	0.05	0.04	0.04	0.04	0.04	0.03	0.03	0.03		
		in.lb	0.71	0.62	0.53	0.53	0.44	0.44	0.44	0.35	0.35	0.35	0.35	0.35	0.27	0.27		
Max. backlash	j_t	arcmin	≤ 10															
Torsional rigidity ^{b)}	C_{t21}	Nm/arcmin	3.3	3.3	3.3	3.3	3.3	3.3	3.3	3.3	3.3	3.3	3.3	2.8	3.3	2.8		
		in.lb/arcmin	29	29	29	29	29	29	29	29	29	29	29	29	25	29	25	
Max. axial force ^{c)}	F_{2AMax}	N	1380															
		lb _f	311															
Max. tilting moment	M_{2KMMax}	Nm	42															
		in.lb	372															
Efficiency at full load	η	%	95															
Service life	L_n	h	> 20000															
Weight (incl. standard adapter plate)	m	kg	2.1															
		lb _m	4.6															
Operating noise (at reference ratio and reference speed – ratio-specific values available in cymex®)	L_{PA}	dB(A)	≤ 58															
Max. permitted housing temperature		°C	+90															
		°F	+194															
Ambient temperature		°C	-15 to +40															
		°F	+5 to +104															
Lubrication			Lubricated for life															
Direction of rotation			In- and output same direction															
Protection class			IP 64															
Elastomer coupling (recommended product type – validate sizing with cymex®)			ELT-00060BAX-031.50															
Bore diameter of coupling on the application side		mm	X = 018.000 - 032.000															
Mass moment of inertia (relates to the drive) Clamping hub diameter [mm]	Z	8	J_1	kgcm ²	0.04	0.04	0.03	0.03	0.03	0.03	0.03	0.03	0.03	0.03	0.02	0.02	0.02	
				10 ⁻³ in.lb.s ²	0.04	0.04	0.03	0.03	0.03	0.03	0.03	0.03	0.03	0.03	0.03	0.03	0.02	0.02
	A	9	J_1	kgcm ²	0.04	0.04	0.03	0.03	0.03	0.03	0.03	0.03	0.03	0.03	0.03	0.02	0.02	0.02
				10 ⁻³ in.lb.s ²	0.04	0.04	0.03	0.03	0.03	0.03	0.03	0.03	0.03	0.03	0.03	0.03	0.02	0.02
	B	11	J_1	kgcm ²	0.06	0.06	0.05	0.05	0.05	0.05	0.05	0.05	0.05	0.05	0.04	0.04	0.04	0.04
				10 ⁻³ in.lb.s ²	0.05	0.05	0.04	0.04	0.04	0.04	0.04	0.04	0.04	0.04	0.04	0.04	0.04	0.04
	C	14	J_1	kgcm ²	0.15	0.14	0.14	0.14	0.13	0.13	0.14	0.13	0.13	0.13	0.13	0.13	0.13	0.13
				10 ⁻³ in.lb.s ²	0.13	0.12	0.12	0.12	0.12	0.12	0.12	0.12	0.12	0.12	0.12	0.12	0.12	0.12

Please use our sizing software cymex® for a detailed sizing – www.wittenstein-cymex.com

^{a)} Valid for torque transmission only

^{b)} Valid for standard clamping hub diameter

^{c)} Refers to center of the output shaft or flange

^{d)} Please reduce input speed at higher ambient temperatures

2-stage

Motor shaft diameter [mm]

up to 11⁴⁾ (B)⁵⁾
clamping hub diameter

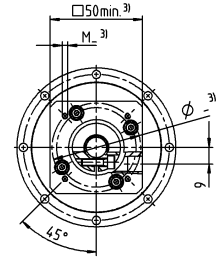
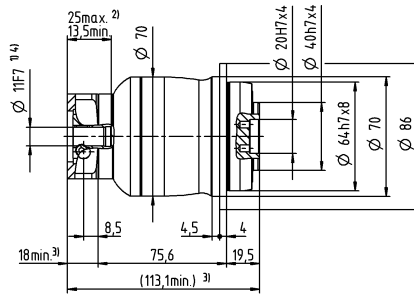
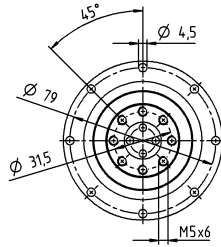

up to 14⁴⁾ (C)
clamping hub diameter

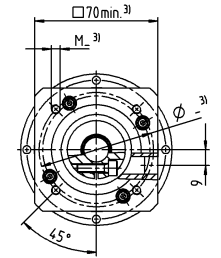
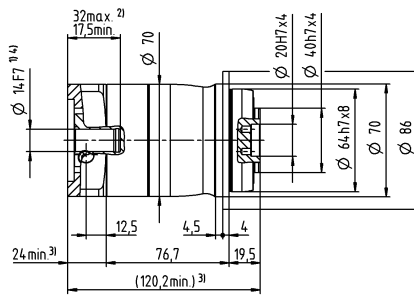
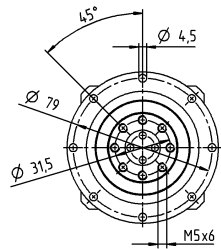

Non-tolerated dimensions are nominal dimensions

¹⁾ Check motor shaft fit

²⁾ Min. / Max. permissible motor shaft length

Longer motor shafts are possible, please contact alpha

³⁾ The dimensions depend on the motor

⁴⁾ Smaller motor shaft diameter is compensated by a bushing with a minimum wall thickness of 1 mm

⁵⁾ Standard clamping hub diameter

NPT 025 MF 1-stage

			1-stage							
Ratio	i		3	4	5	7	8	10		
Max. torque ^{a) b)}	T_{2a}	Nm	128	152	160	160	144	144		
		in.lb	1133	1345	1416	1416	1275	1275		
Max. acceleration torque (max. 1000 cycles per hour)	T_{2B}	Nm	80	95	100	100	90	90		
		in.lb	708	841	885	885	797	797		
Emergency stop torque ^{a) b)} (permitted 1000 times during the service life of the gearbox)	T_{2Not}	Nm	190	190	190	190	190	190		
		in.lb	1682	1682	1682	1682	1682	1682		
Permitted average input speed ^{d)} (at T_{2N} and 20 °C ambient temperature)	n_{1N}	rpm	3100	3300	3400	3600	3700	3900		
Max. input speed	n_{1Max}	rpm	7000	7000	7000	7000	7000	7000		
Mean no load running torque ^{b)} (at $n_1=3000$ rpm and 20 °C gearbox temperature)	T_{012}	Nm	0.43	0.35	0.3	0.24	0.23	0.2		
		in.lb	3.8	3.1	2.7	2.1	2	1.8		
Max. backlash	j_t	arcmin	≤ 8							
Torsional rigidity ^{b)}	C_{t21}	Nm/arcmin	9.5	9.5	9.5	9.5	8.5	8.5		
		in.lb/arcmin	84	84	84	84	75	75		
Max. axial force ^{c)}	F_{2AMax}	N	1900							
		lb _f	428							
Max. tilting moment	M_{2KMMax}	Nm	79							
		in.lb	699							
Efficiency at full load	η	%	97							
Service life	L_n	h	> 20000							
Weight (incl. standard adapter plate)	m	kg	4.4							
		lb _m	9.7							
Operating noise (at reference ratio and reference speed – ratio-specific values available in cymex®)	L_{PA}	dB(A)	≤ 61							
Max. permitted housing temperature		°C	+90							
		°F	+194							
Ambient temperature		°C	-15 to +40							
		°F	+5 to +104							
Lubrication			Lubricated for life							
Direction of rotation			In- and output same direction							
Protection class			IP 64							
Elastomer coupling (recommended product type – validate sizing with cymex®)			ELT-00150BAX-050.00							
Bore diameter of coupling on the application side		mm	X = 024.000 - 036.000							
Mass moment of inertia (relates to the drive) Clamping hub diameter [mm]	C	14	J_1	kgcm ²	0.75	0.57	0.44	0.33	0.3	0.27
				10 ⁻³ in.lb.s ²	0.66	0.5	0.39	0.29	0.27	0.24
	D	16	J_1	kgcm ²	0.9	0.72	0.59	0.46	0.45	0.42
				10 ⁻³ in.lb.s ²	0.8	0.64	0.52	0.41	0.4	0.37
	E	19	J_1	kgcm ²	0.99	0.8	0.67	0.56	0.53	0.5
				10 ⁻³ in.lb.s ²	0.88	0.71	0.59	0.5	0.47	0.44
	G	24	J_1	kgcm ²	2	1.8	1.7	1.6	1.6	1.5
				10 ⁻³ in.lb.s ²	1.8	1.6	1.5	1.4	1.4	1.3
	H	28	J_1	kgcm ²	1.7	1.5	1.4	1.3	1.3	1.2
				10 ⁻³ in.lb.s ²	1.5	1.3	1.2	1.2	1.2	1.1

Please use our sizing software cymex® for a detailed sizing – www.wittenstein-cymex.com

^{a)} Valid for torque transmission only

^{b)} Valid for standard clamping hub diameter

^{c)} Refers to center of the output shaft or flange

^{d)} Please reduce input speed at higher ambient temperatures

1-stage

up to 19⁴⁾ (E)⁵⁾
clamping hub
diameter

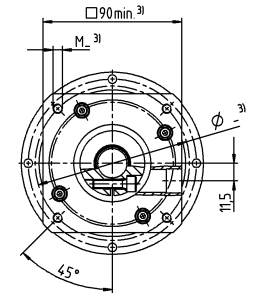
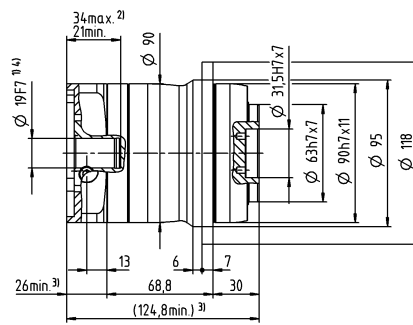
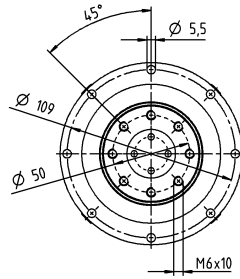

Motor shaft diameter [mm]

up to 28⁴⁾ (H)
clamping hub
diameter

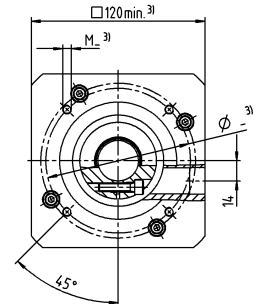
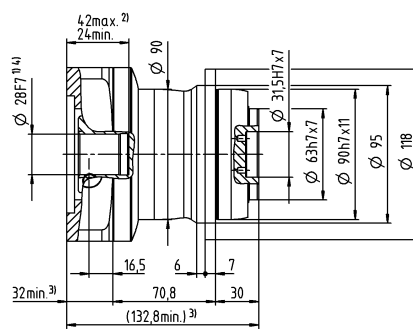
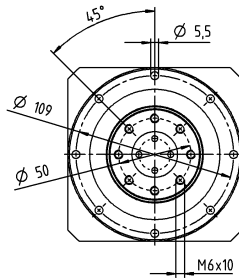

Non-tolerated dimensions are nominal dimensions

¹⁾ Check motor shaft fit

²⁾ Min. / Max. permissible motor shaft length

Longer motor shafts are possible, please contact alpha

³⁾ The dimensions depend on the motor

⁴⁾ Smaller motor shaft diameter is compensated by a bushing with a minimum wall thickness of 1 mm

⁵⁾ Standard clamping hub diameter

NPT 025 MF 2-stage

			2-stage														
Ratio	i		9	12	15	16	20	25	28	30	32	35	40	50	64	70	100
Max. torque ^{a) b)}	T_{2a}	Nm	128	128	128	152	152	160	152	128	152	160	152	160	144	160	144
		in.lb	1133	1133	1133	1345	1345	1416	1345	1133	1345	1416	1345	1416	1275	1416	1275
Max. acceleration torque (max. 1000 cycles per hour)	T_{2B}	Nm	80	80	80	95	95	100	95	80	95	100	95	100	90	100	90
		in.lb	708	708	708	841	841	885	841	708	841	885	841	885	797	885	797
Emergency stop torque ^{a) b)} (permitted 1000 times during the service life of the gearbox)	T_{2Not}	Nm	190	190	190	190	190	190	190	190	190	190	190	190	190	190	190
		in.lb	1682	1682	1682	1682	1682	1682	1682	1682	1682	1682	1682	1682	1682	1682	1682
Permitted average input speed ^{d)} (at T_{2N} and 20 °C ambient temperature)	n_{1N}	rpm	3300	3500	3700	3500	3700	3700	4000	4300	4100	4000	4300	4300	4100	4300	4300
Max. input speed	n_{1Max}	rpm	8000	8000	8000	8000	8000	8000	8000	8000	8000	8000	8000	8000	8000	8000	8000
Mean no load running torque ^{b)} (at $n_1=3000$ rpm and 20 °C gearbox temperature)	T_{012}	Nm	0.16	0.13	0.12	0.11	0.1	0.09	0.09	0.08	0.08	0.08	0.08	0.07	0.07	0.06	0.06
		in.lb	1.4	1.2	1.1	0.97	0.89	0.8	0.8	0.71	0.71	0.71	0.71	0.62	0.62	0.53	0.53
Max. backlash	j_t	arcmin	≤ 10														
Torsional rigidity ^{b)}	C_{t21}	Nm/arcmin	10	10	10	10	10	9.5	10	10	10	9.5	10	9.5	8.5	9.5	8.5
		in.lb/arcmin	89	89	89	89	89	84	89	89	89	84	89	84	75	84	75
Max. axial force ^{c)}	F_{2AMax}	N	1900														
		lb _f	428														
Max. tilting moment	M_{2KMMax}	Nm	79														
		in.lb	699														
Efficiency at full load	η	%	95														
Service life	L_n	h	> 20000														
Weight (incl. standard adapter plate)	m	kg	4.7														
		lb _m	10														
Operating noise (at reference ratio and reference speed – ratio-specific values available in cymex®)	L_{PA}	dB(A)	≤ 59														
Max. permitted housing temperature		°C	+90														
		°F	+194														
Ambient temperature		°C	-15 to +40														
		°F	+5 to +104														
Lubrication			Lubricated for life														
Direction of rotation			In- and output same direction														
Protection class			IP 64														
Elastomer coupling (recommended product type – validate sizing with cymex®)			ELT-00150BAX-050.00														
Bore diameter of coupling on the application side		mm	X = 024.000 - 036.000														
Mass moment of inertia (relates to the drive) Clamping hub diameter [mm]	A	9	J_1	kgcm ²	0.28	0.23	0.22	0.22	0.21	0.2	0.2	0.19	0.19	0.19	0.19	0.19	0.19
				10 ⁻³ in.lb.s ²	0.25	0.2	0.19	0.19	0.19	0.18	0.18	0.17	0.17	0.17	0.17	0.17	0.17
	B	11	J_1	kgcm ²	0.3	0.25	0.23	0.24	0.23	0.22	0.21	0.21	0.21	0.21	0.21	0.21	0.21
				10 ⁻³ in.lb.s ²	0.27	0.22	0.2	0.21	0.2	0.19	0.19	0.19	0.19	0.19	0.19	0.19	0.19
	C	14	J_1	kgcm ²	0.37	0.32	0.31	0.31	0.3	0.29	0.29	0.29	0.29	0.28	0.28	0.28	0.28
				10 ⁻³ in.lb.s ²	0.33	0.28	0.27	0.27	0.27	0.26	0.26	0.26	0.26	0.26	0.25	0.25	0.25
	D	16	J_1	kgcm ²	0.5	0.45	0.44	0.44	0.43	0.42	0.42	0.41	0.41	0.41	0.41	0.41	0.41
				10 ⁻³ in.lb.s ²	0.44	0.4	0.39	0.39	0.38	0.37	0.37	0.36	0.36	0.36	0.36	0.36	0.36
	E	19	J_1	kgcm ²	0.58	0.53	0.52	0.52	0.51	0.51	0.5	0.5	0.5	0.5	0.49	0.49	0.49
				10 ⁻³ in.lb.s ²	0.51	0.47	0.46	0.46	0.45	0.45	0.44	0.44	0.44	0.44	0.43	0.43	0.43

Please use our sizing software cymex® for a detailed sizing – www.wittenstein-cymex.com

^{a)} Valid for torque transmission only

^{b)} Valid for standard clamping hub diameter

^{c)} Refers to center of the output shaft or flange

^{d)} Please reduce input speed at higher ambient temperatures

2-stage

up to 14⁴⁾ (C)⁵⁾
clamping hub
diameter

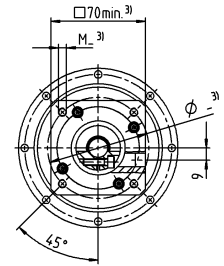
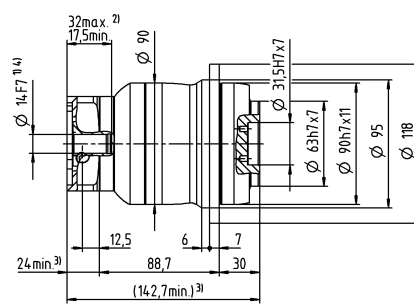
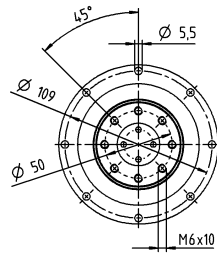

Motor shaft diameter [mm]

up to 19⁴⁾ (E)
clamping hub
diameter

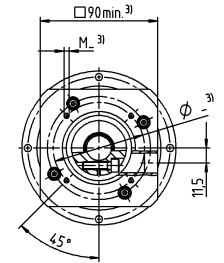
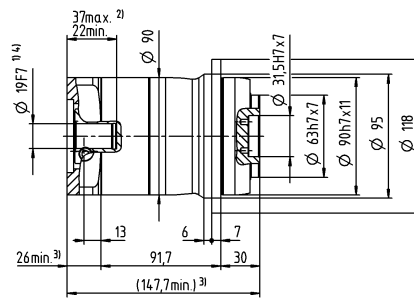
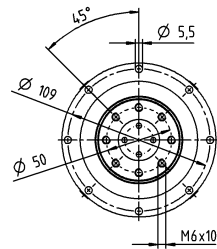

Non-tolerated dimensions are nominal dimensions

¹⁾ Check motor shaft fit

²⁾ Min. / Max. permissible motor shaft length

Longer motor shafts are possible, please contact alpha

³⁾ The dimensions depend on the motor

⁴⁾ Smaller motor shaft diameter is compensated by a bushing with a minimum wall thickness of 1 mm

⁵⁾ Standard clamping hub diameter

NPT 035 MF 1-stage

			1-stage							
Ratio	i		3	4	5	7	8	10		
Max. torque ^{a) b)}	T_{2a}	Nm	320	365	365	365	352	352		
		in.lb	2832	3231	3231	3231	3115	3115		
Max. acceleration torque (max. 1000 cycles per hour)	T_{2B}	Nm	200	255	250	250	220	220		
		in.lb	1770	2257	2213	2213	1947	1947		
Emergency stop torque ^{a) b)} (permitted 1000 times during the service life of the gearbox)	T_{2Not}	Nm	480	480	480	480	480	480		
		in.lb	4248	4248	4248	4248	4248	4248		
Permitted average input speed ^{d)} (at T_{2N} and 20 °C ambient temperature)	n_{1N}	rpm	2300	2500	2600	2800	2900	3000		
Max. input speed	n_{1Max}	rpm	6000	6000	6000	6000	6000	6000		
Mean no load running torque ^{b)} (at $n_1=3000$ rpm and 20 °C gearbox temperature)	T_{012}	Nm	1.7	1.3	1.1	0.79	0.71	0.6		
		in.lb	15	12	9.7	7	6.3	5.3		
Max. backlash	j_t	arcmin	≤ 8							
Torsional rigidity ^{b)}	C_{t21}	Nm/arcmin	25	25	25	25	22	22		
		in.lb/arcmin	221	221	221	221	195	195		
Max. axial force ^{c)}	F_{2AMax}	N	3500							
		lb _f	788							
Max. tilting moment	M_{2KMMax}	Nm	134							
		in.lb	1186							
Efficiency at full load	η	%	97							
Service life	L_n	h	> 20000							
Weight (incl. standard adapter plate)	m	kg	9.4							
		lb _m	21							
Operating noise (at reference ratio and reference speed – ratio-specific values available in cymex®)	L_{PA}	dB(A)	≤ 65							
Max. permitted housing temperature		°C	+90							
		°F	+194							
Ambient temperature		°C	-15 to +40							
		°F	+5 to +104							
Lubrication			Lubricated for life							
Direction of rotation			In- and output same direction							
Protection class			IP 64							
Elastomer coupling (recommended product type – validate sizing with cymex®)			ELT-00300BAX-063.00							
Bore diameter of coupling on the application side		mm	X = 035.000 - 045.000							
Mass moment of inertia (relates to the drive) Clamping hub diameter [mm]	E	19	J_1	kgcm ²	3.2	2	1.6	1.2	1	0.93
				10 ⁻³ in.lb.s ²	2.8	1.8	1.4	1.1	0.89	0.82
	G	24	J_1	kgcm ²	4	2.8	2.4	1.9	1.8	1.7
				10 ⁻³ in.lb.s ²	3.5	2.5	2.1	1.7	1.6	1.5
	H	28	J_1	kgcm ²	3.7	2.5	2.1	1.6	1.5	1.4
				10 ⁻³ in.lb.s ²	3.3	2.2	1.9	1.4	1.3	1.2
	I	32	J_1	kgcm ²	7.7	6.6	6.1	5.7	5.6	5.5
				10 ⁻³ in.lb.s ²	6.8	5.8	5.4	5	5	4.9
	K	38	J_1	kgcm ²	8.9	7.8	7.3	6.9	6.7	6.6
				10 ⁻³ in.lb.s ²	7.9	6.9	6.5	6.1	5.9	5.8

Please use our sizing software cymex® for a detailed sizing – www.wittenstein-cymex.com

^{a)} Valid for torque transmission only

^{b)} Valid for standard clamping hub diameter

^{c)} Refers to center of the output shaft or flange

^{d)} Please reduce input speed at higher ambient temperatures

1-stage

up to 24/28⁴⁾
(G⁵⁾/H)
clamping hub diameter

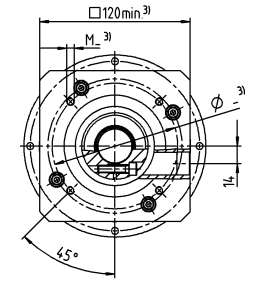
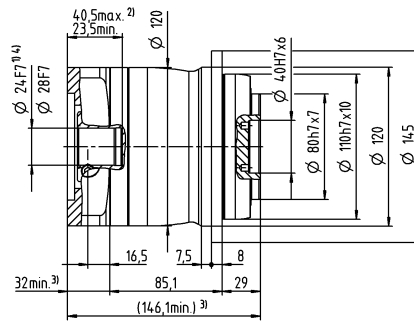
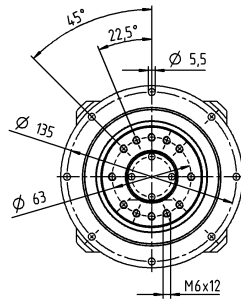

Motor shaft diameter [mm]

up to 38⁴⁾ (K)
clamping hub diameter

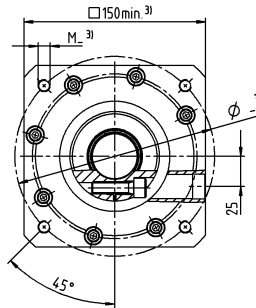
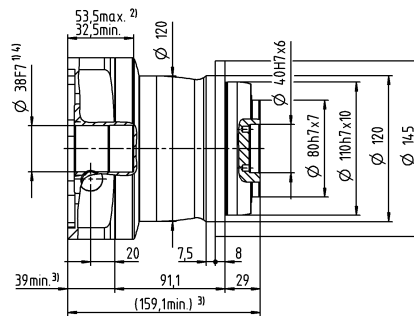
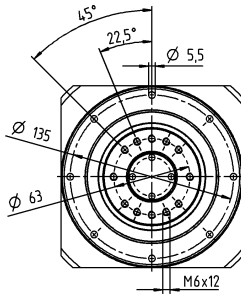

Non-tolerated dimensions are nominal dimensions

¹⁾ Check motor shaft fit

²⁾ Min. / Max. permissible motor shaft length

Longer motor shafts are possible, please contact alpha

³⁾ The dimensions depend on the motor

⁴⁾ Smaller motor shaft diameter is compensated by a bushing with a minimum wall thickness of 1 mm

⁵⁾ Standard clamping hub diameter

NPT 035 MF 2-stage

			2-stage																
Ratio	i		9	12	15	16	20	25	28	30	32	35	40	50	64	70	100		
Max. torque ^{a) b)}	T_{2a}	Nm	320	320	320	365	365	365	365	320	365	365	365	365	352	365	352		
		in.lb	2832	2832	2832	3231	3231	3231	3231	2832	3231	3231	3231	3231	3115	3231	3115		
Max. acceleration torque (max. 1000 cycles per hour)	T_{2B}	Nm	200	200	200	255	255	250	255	200	255	250	255	250	220	250	220		
		in.lb	1770	1770	1770	2257	2257	2213	2257	1770	2257	2213	2257	2213	1947	2213	1947		
Emergency stop torque ^{a) b)} (permitted 1000 times during the service life of the gearbox)	T_{2Not}	Nm	480	480	480	480	480	480	480	480	480	480	480	480	480	480	480		
		in.lb	4248	4248	4248	4248	4248	4248	4248	4248	4248	4248	4248	4248	4248	4248	4248		
Permitted average input speed ^{d)} (at T_{2N} and 20 °C ambient temperature)	n_{1N}	rpm	3100	3300	3400	3300	3400	3400	3600	3900	3700	3600	3900	3900	3700	3900	3900		
Max. input speed	n_{1Max}	rpm	7000	7000	7000	7000	7000	7000	7000	7000	7000	7000	7000	7000	7000	7000	7000		
Mean no load running torque ^{b)} (at $n_1=3000$ rpm and 20 °C gearbox temperature)	T_{012}	Nm	0.6	0.48	0.4	0.38	0.33	0.28	0.26	0.25	0.24	0.23	0.21	0.19	0.17	0.16	0.15		
		in.lb	5.3	4.2	3.5	3.4	2.9	2.5	2.3	2.2	2.1	2	1.9	1.7	1.5	1.4	1.3		
Max. backlash	j_t	arcmin	≤ 10																
Torsional rigidity ^{b)}	C_{t21}	Nm/arcmin	25	25	25	25	25	25	25	25	25	25	25	25	22	25	22		
		in.lb/arcmin	221	221	221	221	221	221	221	221	221	221	221	221	195	221	195		
Max. axial force ^{c)}	F_{2AMax}	N	3500																
		lb _f	788																
Max. tilting moment	M_{2KMMax}	Nm	134																
		in.lb	1186																
Efficiency at full load	η	%	95																
Service life	L_n	h	> 20000																
Weight (incl. standard adapter plate)	m	kg	9.8																
		lb _m	22																
Operating noise (at reference ratio and reference speed – ratio-specific values available in cymex®)	L_{PA}	dB(A)	≤ 61																
Max. permitted housing temperature		°C	+90																
		°F	+194																
Ambient temperature		°C	-15 to +40																
		°F	+5 to +104																
Lubrication			Lubricated for life																
Direction of rotation			In- and output same direction																
Protection class			IP 64																
Elastomer coupling (recommended product type – validate sizing with cymex®)			ELT-00300BAX-063.00																
Bore diameter of coupling on the application side		mm	X = 035.000 - 045.000																
Mass moment of inertia (relates to the drive) Clamping hub diameter [mm]	C	14	J_1	kgcm ²	0.68	0.63	0.62	0.45	0.44	0.37	0.38	0.52	0.38	0.32	0.37	0.31	0.26	0.27	0.24
				10 ⁻³ in.lb.s ²	0.6	0.56	0.55	0.4	0.39	0.33	0.34	0.46	0.34	0.28	0.33	0.27	0.23	0.24	0.21
	D	16	J_1	kgcm ²	0.82	0.78	0.77	0.6	0.58	0.51	0.51	0.67	0.53	0.45	0.52	0.46	0.4	0.41	0.39
				10 ⁻³ in.lb.s ²	0.73	0.69	0.68	0.53	0.51	0.45	0.45	0.59	0.47	0.4	0.46	0.41	0.35	0.36	0.35
	E	19	J_1	kgcm ²	0.91	0.87	0.86	0.69	0.67	0.6	0.61	0.76	0.61	0.55	0.6	0.55	0.49	0.5	0.48
				10 ⁻³ in.lb.s ²	0.81	0.77	0.76	0.61	0.59	0.53	0.54	0.67	0.54	0.49	0.53	0.49	0.43	0.44	0.42
	G	24	J_1	kgcm ²	1.9	1.9	1.9	1.7	1.7	1.6	1.6	1.8	1.7	1.6	1.6	1.5	1.5	1.5	
				10 ⁻³ in.lb.s ²	1.7	1.7	1.7	1.5	1.5	1.4	1.4	1.6	1.5	1.4	1.4	1.4	1.3	1.3	1.3
	H	28	J_1	kgcm ²	1.7	1.6	1.6	1.4	1.4	1.3	1.4	1.5	1.4	1.3	1.3	1.3	1.2	1.2	1.2
				10 ⁻³ in.lb.s ²	1.5	1.4	1.4	1.2	1.2	1.2	1.2	1.3	1.2	1.2	1.2	1.2	1.1	1.1	1.1

Please use our sizing software cymex® for a detailed sizing – www.wittenstein-cymex.com

^{a)} Valid for torque transmission only

^{b)} Valid for standard clamping hub diameter

^{c)} Refers to center of the output shaft or flange

^{d)} Please reduce input speed at higher ambient temperatures

2-stage

Motor shaft diameter [mm]

up to 19⁴⁾ (E)⁵⁾
clamping hub diameter

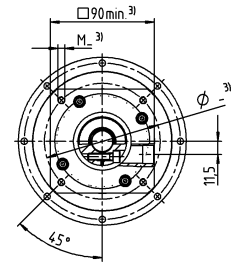
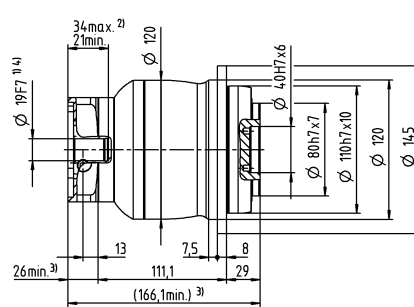
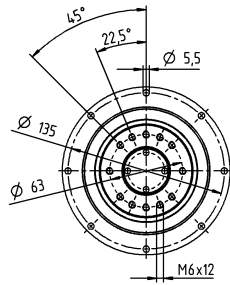

up to 28⁴⁾ (H)
clamping hub diameter

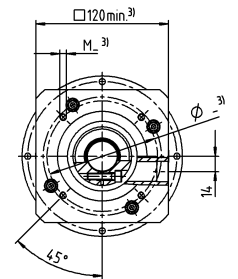
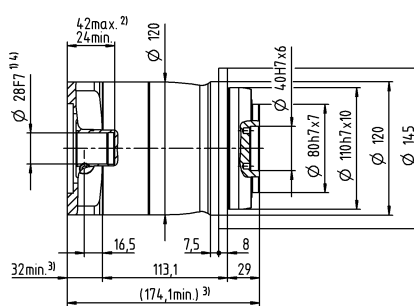
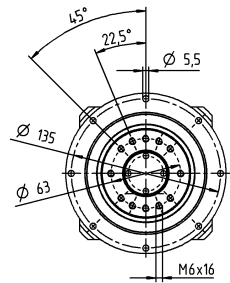

Non-tolerated dimensions are nominal dimensions

¹⁾ Check motor shaft fit

²⁾ Min. / Max. permissible motor shaft length

Longer motor shafts are possible, please contact alpha

³⁾ The dimensions depend on the motor

⁴⁾ Smaller motor shaft diameter is compensated by a bushing with a minimum wall thickness of 1 mm

⁵⁾ Standard clamping hub diameter

NPT 045 MF 1-/2-stage

			1-stage			2-stage						
Ratio	i		5	8	10	25	32	50	64	100		
Max. torque ^{a) b)}	T_{2a}	Nm	700	640	640	700	640	700	640	640		
		in.lb	6196	5665	5665	6196	5665	6196	5665	5665		
Max. acceleration torque (max. 1000 cycles per hour)	T_{2B}	Nm	500	400	400	500	400	500	400	400		
		in.lb	4425	3540	3540	4425	3540	4425	3540	3540		
Emergency stop torque ^{a) b)} (permitted 1000 times during the service life of the gearbox)	T_{2Not}	Nm	1000	1000	1000	1000	1000	1000	1000	1000		
		in.lb	8851	8851	8851	8851	8851	8851	8851	8851		
Permitted average input speed ^{d)} (at T_{2N} and 20 °C ambient temperature)	n_{1N}	rpm	2000	2200	2300	2600	2500	3000	2900	3000		
Max. input speed	n_{1Max}	rpm	4000	4000	4000	6000	6000	6000	6000	6000		
Mean no load running torque ^{b)} (at $n_1=3000$ rpm and 20 °C gearbox temperature)	T_{012}	Nm	1.5	1.1	0.9	0.39	0.34	0.27	0.24	0.21		
		in.lb	13	9.7	8	3.5	3	2.4	2.1	1.9		
Max. backlash	j_t	arcmin	≤ 8			≤ 10						
Torsional rigidity ^{b)}	C_{t21}	Nm/arcmin	55	44	44	55	44	55	44	44		
		in.lb/arcmin	487	389	389	487	389	487	389	389		
Max. axial force ^{c)}	F_{2AMax}	N	3800			3800						
		lb _f	855			855						
Max. tilting moment	M_{2KMax}	Nm	256			256						
		in.lb	2266			2266						
Efficiency at full load	η	%	97			95						
Service life	L_n	h	> 20000			> 20000						
Weight (incl. standard adapter plate)	m	kg	19			20						
		lb _m	42			44						
Operating noise (at reference ratio and reference speed – ratio-specific values available in cymex®)	L_{PA}	dB(A)	≤ 68			≤ 65						
Max. permitted housing temperature		°C	+90			+90						
		°F	+194			+194						
Ambient temperature		°C	-15 to +40			-15 to +40						
		°F	+5 to +104			+5 to +104						
Lubrication			Lubricated for life									
Direction of rotation			In- and output same direction									
Protection class			IP 64									
Elastomer coupling (recommended product type – validate sizing with cymex®)			ELT-00450BAX-080.00									
Bore diameter of coupling on the application side		mm	X = 042.000 - 060.000									
Mass moment of inertia (relates to the drive) Clamping hub diameter [mm]	E	19	J_1	kgcm ²	-	-	-	1.3	1.1	1.1	0.88	0.83
				10 ⁻³ in.lb.s ²	-	-	-	1.2	0.97	0.97	0.78	0.73
	G	24	J_1	kgcm ²	-	-	-	2	1.9	1.8	1.7	1.6
				10 ⁻³ in.lb.s ²	-	-	-	1.8	1.7	1.6	1.5	1.4
	H	28	J_1	kgcm ²	-	-	-	1.8	1.6	1.6	1.4	1.3
				10 ⁻³ in.lb.s ²	-	-	-	1.6	1.4	1.4	1.2	1.2
	I	32	J_1	kgcm ²	-	-	-	5.8	5.7	5.6	5.4	5.4
				10 ⁻³ in.lb.s ²	-	-	-	5.1	5	5	4.8	4.8
	K	38	J_1	kgcm ²	9.8	7.8	7.4	7	6.9	6.8	6.6	6.5
				10 ⁻³ in.lb.s ²	8.7	6.9	6.5	6.2	6.1	6	5.8	5.8

Please use our sizing software cymex® for a detailed sizing – www.wittenstein-cymex.com

^{a)} Valid for torque transmission only

^{b)} Valid for standard clamping hub diameter

^{c)} Refers to center of the output shaft or flange

^{d)} Please reduce input speed at higher ambient temperatures

1-stage

up to 38⁴⁾ (K)⁵⁾
clamping hub diameter

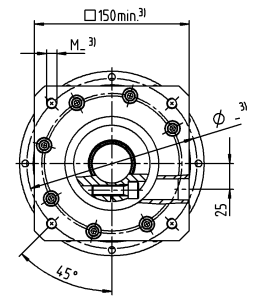
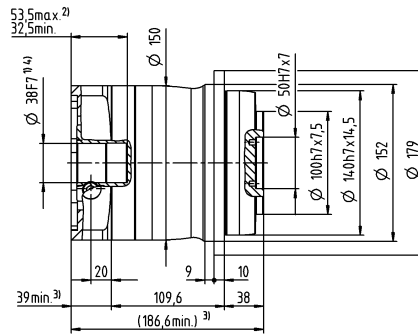
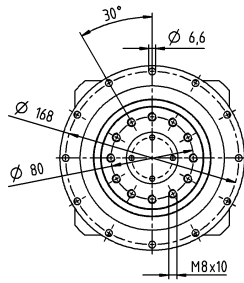

2-stage

up to 28⁴⁾ (H)⁵⁾
clamping hub diameter

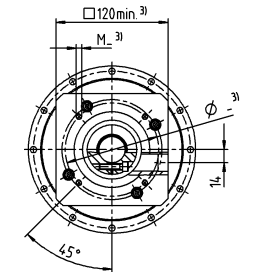
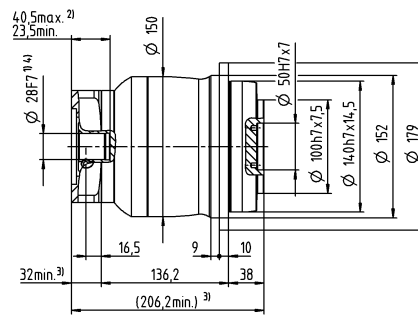
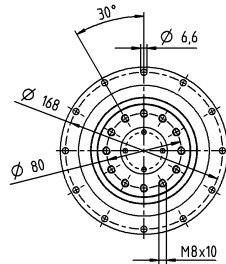

Motor shaft diameter [mm]

up to 38⁴⁾ (K)
clamping hub diameter

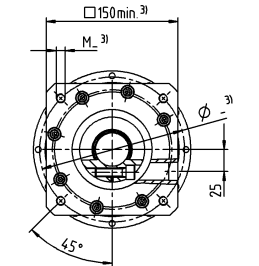
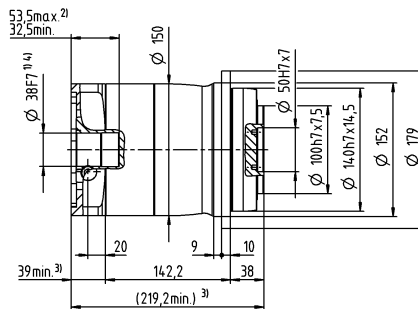
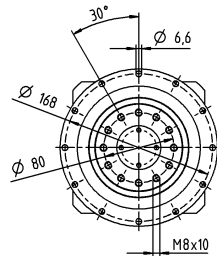

Non-tolerated dimensions are nominal dimensions

¹⁾ Check motor shaft fit

²⁾ Min. / Max. permissible motor shaft length

Longer motor shafts are possible, please contact alpha

³⁾ The dimensions depend on the motor

⁴⁾ Smaller motor shaft diameter is compensated

by a bushing with a minimum wall thickness of 1 mm

⁵⁾ Standard clamping hub diameter

NPT 015 MA 1-/2-stage

			1-stage		2-stage							
Ratio	i		3	4	12	15	16	20	28	30	40	
Max. torque ^{a) b)}	T_{2a}	Nm	62	62	62	62	62	62	62	62	62	
		in.lb	549	549	549	549	549	549	549	549	549	
Max. acceleration torque (max. 1000 cycles per hour)	T_{2B}	Nm	55	42	39	42	42	42	42	42	39	42
		in.lb	487	372	345	372	372	372	372	372	345	372
Emergency stop torque ^{a) b)} (permitted 1000 times during the service life of the gearbox)	T_{2Not}	Nm	75	75	75	75	75	75	75	75	75	
		in.lb	664	664	664	664	664	664	664	664	664	
Permitted average input speed ^{d)} (at T_{2N} and 20 °C ambient temperature)	n_{1N}	rpm	3300	3500	3800	4000	3800	4000	4300	4600	4600	
Max. input speed	n_{1Max}	rpm	8000	8000	10000	10000	10000	10000	10000	10000	10000	
Mean no load running torque ^{b)} (at $n_1=3000$ rpm and 20 °C gearbox temperature)	T_{012}	Nm	0.25	0.2	0.08	0.07	0.06	0.06	0.05	0.05	0.04	
		in.lb	2.2	1.8	0.71	0.62	0.53	0.53	0.44	0.44	0.35	
Max. backlash	j_t	arcmin	≤ 8		≤ 10							
Torsional rigidity ^{b)}	C_{t21}	Nm/arcmin	4	4	4	4	4	4	4	4	4	
		in.lb/arcmin	35	35	35	35	35	35	35	35	35	
Max. axial force ^{c)}	F_{2AMax}	N	1380				1380					
		lb _f	311				311					
Max. tilting moment	M_{2KMMax}	Nm	42				42					
		in.lb	372				372					
Efficiency at full load	η	%	97				95					
Service life	L_n	h	> 20000				> 20000					
Weight (incl. standard adapter plate)	m	kg	2				2.1					
		lb _m	4.4				4.6					
Operating noise (at reference ratio and reference speed – ratio-specific values available in cymex®)	L_{PA}	dB(A)	≤ 59				≤ 58					
Max. permitted housing temperature		°C	+90				+90					
		°F	+194				+194					
Ambient temperature		°C	-15 to +40				-15 to +40					
		°F	+5 to +104				+5 to +104					
Lubrication			Lubricated for life									
Direction of rotation			In- and output same direction									
Protection class			IP 64									
Elastomer coupling (recommended product type – validate sizing with cymex®)			ELT-00060BAX-031.50									
Bore diameter of coupling on the application side		mm	X = 018.000 - 032.000									
Mass moment of inertia (relates to the drive) Clamping hub diameter [mm]	Z	8	J_1	kgcm ²	–	–	0.04	0.04	0.03	0.03	0.03	0.03
				10 ⁻³ in.lb.s ²	–	–	0.04	0.04	0.03	0.03	0.03	0.03
	A	9	J_1	kgcm ²	0.31	0.23	0.04	0.04	0.03	0.03	0.03	0.03
				10 ⁻³ in.lb.s ²	0.27	0.2	0.04	0.04	0.03	0.03	0.03	0.03
	B	11	J_1	kgcm ²	0.33	0.24	0.06	0.06	0.05	0.05	0.05	0.05
				10 ⁻³ in.lb.s ²	0.29	0.21	0.05	0.05	0.04	0.04	0.04	0.04
	C	14	J_1	kgcm ²	0.41	0.32	0.15	0.14	0.14	0.14	0.13	0.14
				10 ⁻³ in.lb.s ²	0.36	0.28	0.13	0.12	0.12	0.12	0.12	0.12
	D	16	J_1	kgcm ²	0.53	0.45	–	–	–	–	–	–
				10 ⁻³ in.lb.s ²	0.47	0.4	–	–	–	–	–	–
	E	19	J_1	kgcm ²	0.62	0.53	–	–	–	–	–	–
				10 ⁻³ in.lb.s ²	0.55	0.47	–	–	–	–	–	–

Please use our sizing software cymex® for a detailed sizing – www.wittenstein-cymex.com

^{a)} Valid for torque transmission only

^{b)} Valid for standard clamping hub diameter

^{c)} Refers to center of the output shaft or flange

^{d)} Please reduce input speed at higher ambient temperatures

1-stage

up to 14⁴⁾ (C)⁵⁾
clamping hub diameter

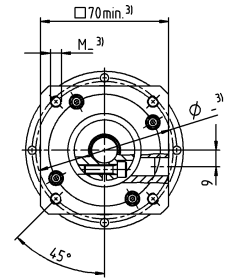
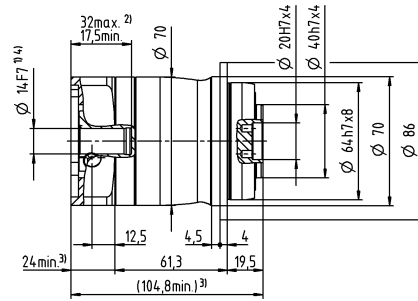
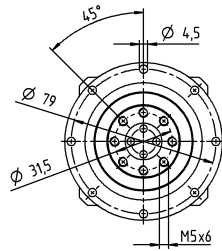

up to 19⁴⁾ (E)
clamping hub diameter

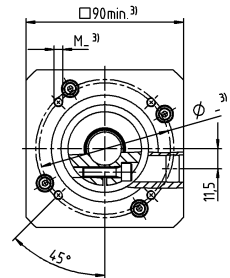
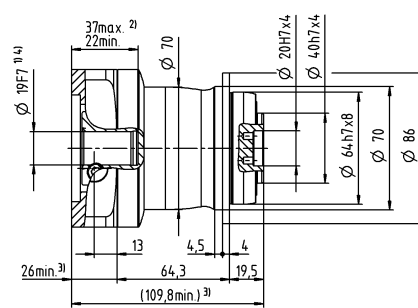
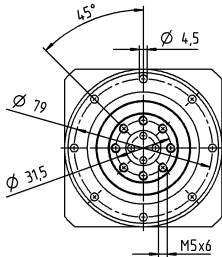

2-stage

up to 11⁴⁾ (B)⁵⁾
clamping hub diameter

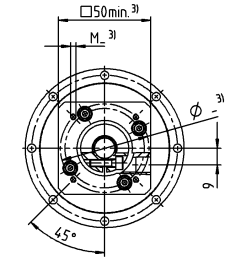
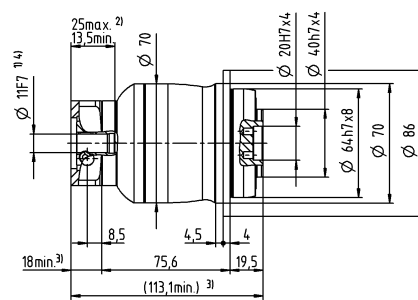
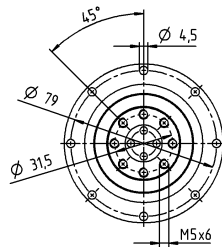

up to 14⁴⁾ (C)
clamping hub diameter

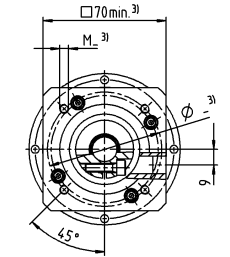
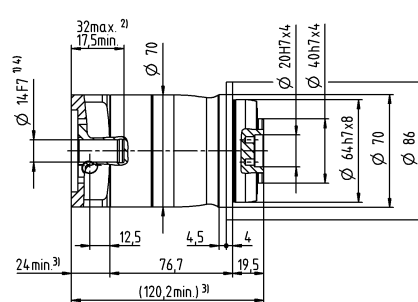
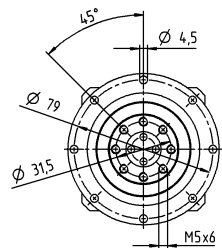

Motor shaft diameter [mm]

Non-tolerated dimensions are nominal dimensions

¹⁾ Check motor shaft fit

²⁾ Min. / Max. permissible motor shaft length

Longer motor shafts are possible, please contact alpha

³⁾ The dimensions depend on the motor

⁴⁾ Smaller motor shaft diameter is compensated

by a bushing with a minimum wall thickness of 1 mm

⁵⁾ Standard clamping hub diameter

NPT 025 MA 1-/2-stage

			1-stage		2-stage									
Ratio	i		3	4	9	12	15	16	20	28	30	40		
Max. torque ^{a) b)}	T_{2a}	Nm	185	185	185	185	185	185	185	185	168	185		
		in.lb	1637	1637	1637	1637	1637	1637	1637	1637	1637	1487	1637	
Max. acceleration torque (max. 1000 cycles per hour)	T_{2B}	Nm	125	115	125	125	120	115	115	115	105	115		
		in.lb	1106	1018	1106	1106	1062	1018	1018	1018	929	1018		
Emergency stop torque ^{a) b)} (permitted 1000 times during the service life of the gearbox)	T_{2Not}	Nm	190	190	190	190	190	190	190	190	190	190		
		in.lb	1682	1682	1682	1682	1682	1682	1682	1682	1682	1682		
Permitted average input speed ^{d)} (at T_{2N} and 20 °C ambient temperature)	n_{1N}	rpm	3100	3300	3300	3500	3700	3500	3700	4000	4300	4300		
Max. input speed	n_{1Max}	rpm	7000	7000	8000	8000	8000	8000	8000	8000	8000	8000		
Mean no load running torque ^{b)} (at $n_1=3000$ rpm and 20 °C gearbox temperature)	T_{012}	Nm	0.43	0.35	0.16	0.13	0.12	0.11	0.1	0.09	0.08	0.08		
		in.lb	3.8	3.1	1.4	1.2	1.1	0.97	0.89	0.8	0.71	0.71		
Max. backlash	j_t	arcmin	≤ 8		≤ 10									
Torsional rigidity ^{b)}	C_{t21}	Nm/arcmin	12	12	12	12	12	12	12	12	12	12		
		in.lb/arcmin	106	106	106	106	106	106	106	106	106	106		
Max. axial force ^{c)}	F_{2AMax}	N	1900				1900							
		lb _f	428				428							
Max. tilting moment	M_{2KMax}	Nm	79				79							
		in.lb	699				699							
Efficiency at full load	η	%	97				95							
Service life	L_n	h	> 20000				> 20000							
Weight (incl. standard adapter plate)	m	kg	4.4				4.7							
		lb _m	9.7				10							
Operating noise (at reference ratio and reference speed – ratio-specific values available in cymex®)	L_{PA}	dB(A)	≤ 61				≤ 59							
Max. permitted housing temperature		°C	+90				+90							
		°F	+194				+194							
Ambient temperature		°C	-15 to +40				-15 to +40							
		°F	+5 to +104				+5 to +104							
Lubrication			Lubricated for life											
Direction of rotation			In- and output same direction											
Protection class			IP 64											
Elastomer coupling (recommended product type – validate sizing with cymex®)			ELT-00150BAX-050.00											
Bore diameter of coupling on the application side		mm	X = 024.000 - 036.000											
Mass moment of inertia (relates to the drive) Clamping hub diameter [mm]	A	9	J_1	kgcm ²	–	–	0.28	0.23	0.22	0.22	0.21	0.20	0.19	0.19
				10 ⁻³ in.lb.s ²	–	–	0.25	0.2	0.19	0.19	0.19	0.18	0.17	0.17
	B	11	J_1	kgcm ²	–	–	0.3	0.25	0.23	0.24	0.23	0.21	0.21	0.21
				10 ⁻³ in.lb.s ²	–	–	0.27	0.22	0.2	0.21	0.2	0.19	0.19	0.19
	C	14	J_1	kgcm ²	0.75	0.57	0.37	0.32	0.31	0.31	0.3	0.29	0.29	0.28
				10 ⁻³ in.lb.s ²	0.66	0.5	0.33	0.28	0.27	0.27	0.27	0.26	0.26	0.25
	D	16	J_1	kgcm ²	0.9	0.72	0.5	0.45	0.44	0.44	0.43	0.42	0.41	0.41
				10 ⁻³ in.lb.s ²	0.8	0.64	0.44	0.4	0.39	0.39	0.38	0.37	0.36	0.36
	E	19	J_1	kgcm ²	0.99	0.8	0.58	0.53	0.52	0.52	0.51	0.5	0.5	0.49
				10 ⁻³ in.lb.s ²	0.88	0.71	0.51	0.47	0.46	0.46	0.45	0.44	0.44	0.43
	G	24	J_1	kgcm ²	2	1.8	–	–	–	–	–	–	–	–
				10 ⁻³ in.lb.s ²	1.8	1.6	–	–	–	–	–	–	–	–
	H	28	J_1	kgcm ²	1.7	1.5	–	–	–	–	–	–	–	–
				10 ⁻³ in.lb.s ²	1.5	1.3	–	–	–	–	–	–	–	–

Please use our sizing software cymex® for a detailed sizing – www.wittenstein-cymex.com

^{a)} Valid for torque transmission only

^{b)} Valid for standard clamping hub diameter

^{c)} Refers to center of the output shaft or flange

^{d)} Please reduce input speed at higher ambient temperatures

1-stage

up to 19⁴⁾ (E)⁵⁾
clamping hub
diameter

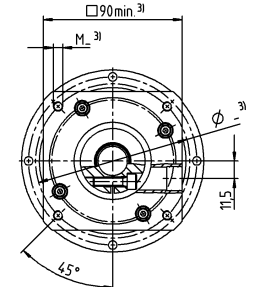
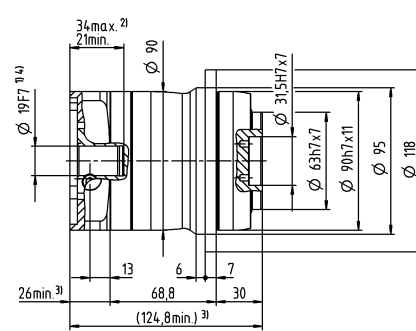
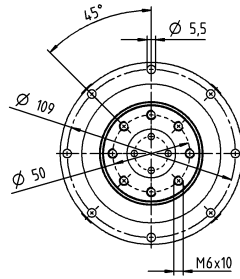

up to 28⁴⁾ (H)
clamping hub
diameter

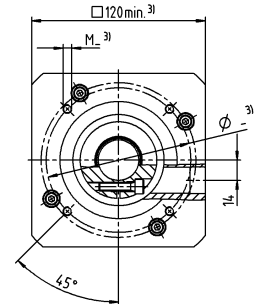
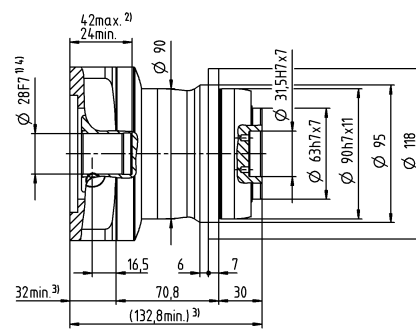
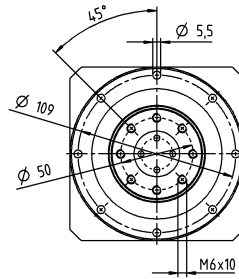

2-stage

up to 14⁴⁾ (C)⁵⁾
clamping hub
diameter

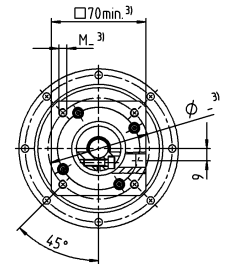
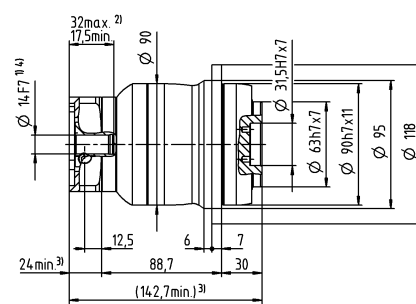
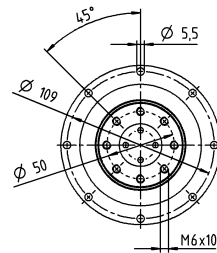

up to 19⁴⁾ (E)
clamping hub
diameter

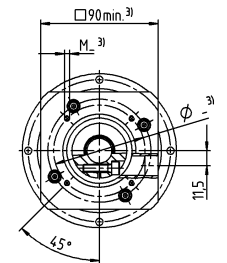
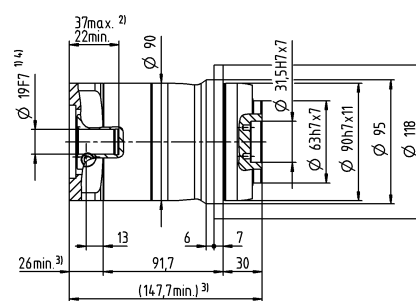
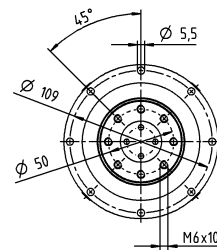

Motor shaft diameter [mm]

Non-tolerated dimensions are nominal dimensions

¹⁾ Check motor shaft fit

²⁾ Min. / Max. permissible motor shaft length

Longer motor shafts are possible, please contact alpha

³⁾ The dimensions depend on the motor

⁴⁾ Smaller motor shaft diameter is compensated

by a bushing with a minimum wall thickness of 1 mm

⁵⁾ Standard clamping hub diameter

NPT 035 MA 1-/2-stage

			1-stage		2-stage									
Ratio	i		3	4	9	12	15	16	20	28	30	40		
Max. torque ^{a) b)}	T_{2a}	Nm	380	380	380	380	380	380	380	380	370	380		
		in.lb	3363	3363	3363	3363	3363	3363	3363	3363	3363	3275	3363	
Max. acceleration torque (max. 1000 cycles per hour)	T_{2B}	Nm	305	305	305	305	300	305	305	305	270	305		
		in.lb	2699	2699	2699	2699	2655	2699	2699	2699	2390	2699		
Emergency stop torque ^{a) b)} (permitted 1000 times during the service life of the gearbox)	T_{2Not}	Nm	480	480	480	480	480	480	480	480	480	480		
		in.lb	4248	4248	4248	4248	4248	4248	4248	4248	4248	4248		
Permitted average input speed ^{d)} (at T_{2N} and 20 °C ambient temperature)	n_{1N}	rpm	2300	2500	3100	3300	3400	3300	3400	3600	3900	3900		
Max. input speed	n_{1Max}	rpm	6000	6000	7000	7000	7000	7000	7000	7000	7000	7000		
Mean no load running torque ^{b)} (at $n_1=3000$ rpm and 20 °C gearbox temperature)	T_{012}	Nm	1.7	1.3	0.6	0.48	0.4	0.38	0.33	0.26	0.25	0.21		
		in.lb	15	12	5.3	4.2	3.5	3.4	2.9	2.3	2.2	1.9		
Max. backlash	j_t	arcmin	≤ 8		≤ 10									
Torsional rigidity ^{b)}	C_{t21}	Nm/arcmin	30	30	30	30	30	30	30	30	30	30		
		in.lb/arcmin	266	266	266	266	266	266	266	266	266	266		
Max. axial force ^{c)}	F_{2AMax}	N	3500				3500							
		lb _f	788				788							
Max. tilting moment	M_{2KMax}	Nm	134				134							
		in.lb	1186				1186							
Efficiency at full load	η	%	97				95							
Service life	L_n	h	> 20000				> 20000							
Weight (incl. standard adapter plate)	m	kg	9.4				9.8							
		lb _m	21				22							
Operating noise (at reference ratio and reference speed – ratio-specific values available in cymex®)	L_{PA}	dB(A)	≤ 65				≤ 61							
Max. permitted housing temperature		°C	+90				+90							
		°F	+194				+194							
Ambient temperature		°C	-15 to +40				-15 to +40							
		°F	+5 to +104				+5 to +104							
Lubrication			Lubricated for life											
Direction of rotation			In- and output same direction											
Protection class			IP 64											
Elastomer coupling (recommended product type – validate sizing with cymex®)			ELT-00300BAX-063.00											
Bore diameter of coupling on the application side		mm	X = 035.000 - 045.000											
Mass moment of inertia (relates to the drive) Clamping hub diameter [mm]	C	14	J_1	kgcm ²	–	–	0.68	0.63	0.62	0.45	0.44	0.38	0.52	0.37
				10 ⁻³ in.lb.s ²	–	–	0.6	0.56	0.55	0.4	0.39	0.34	0.46	0.33
	D	16	J_1	kgcm ²	–	–	0.82	0.78	0.77	0.6	0.58	0.51	0.67	0.52
				10 ⁻³ in.lb.s ²	–	–	0.73	0.69	0.68	0.53	0.51	0.45	0.59	0.46
	E	19	J_1	kgcm ²	3.2	2	0.91	0.87	0.86	0.69	0.67	0.61	0.76	0.6
				10 ⁻³ in.lb.s ²	2.8	1.8	0.81	0.77	0.76	0.61	0.59	0.54	0.67	0.53
	G	24	J_1	kgcm ²	4	2.8	1.9	1.9	1.9	1.7	1.7	1.6	1.8	1.6
				10 ⁻³ in.lb.s ²	3.5	2.5	1.7	1.7	1.7	1.5	1.5	1.4	1.6	1.4
	H	28	J_1	kgcm ²	3.7	2.5	1.7	1.6	1.6	1.4	1.4	1.4	1.5	1.3
				10 ⁻³ in.lb.s ²	3.3	2.2	1.5	1.4	1.4	1.2	1.2	1.2	1.3	1.2
	I	32	J_1	kgcm ²	7.7	6.6	–	–	–	–	–	–	–	–
				10 ⁻³ in.lb.s ²	6.8	5.8	–	–	–	–	–	–	–	–
	K	38	J_1	kgcm ²	8.9	7.8	–	–	–	–	–	–	–	–
				10 ⁻³ in.lb.s ²	7.9	6.9	–	–	–	–	–	–	–	–

Please use our sizing software cymex® for a detailed sizing – www.wittenstein-cymex.com

^{a)} Valid for torque transmission only

^{b)} Valid for standard clamping hub diameter

^{c)} Refers to center of the output shaft or flange

^{d)} Please reduce input speed at higher ambient temperatures

1-stage

up to 24/28⁴⁾
(G⁵⁾/H)
clamping hub
diameter

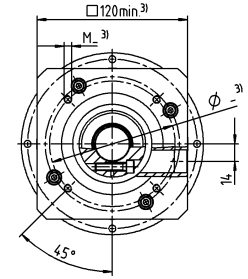
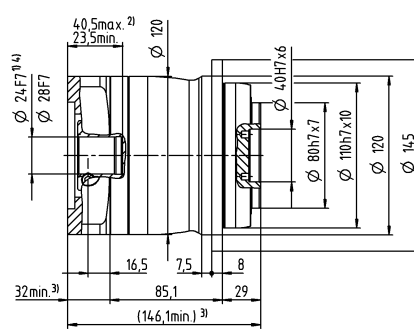
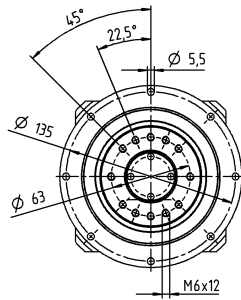

up to 38⁴⁾ (K)
clamping hub
diameter

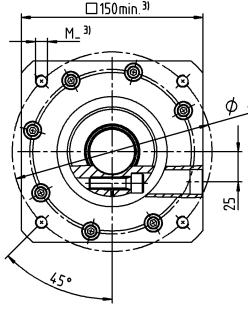
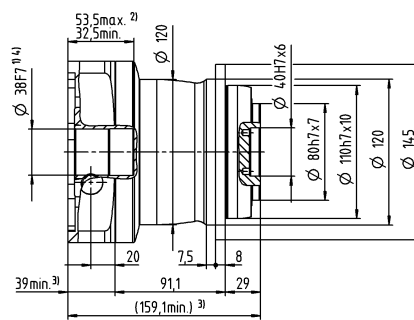
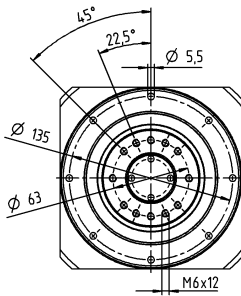

2-stage

up to 19⁴⁾ (E)⁵⁾
clamping hub
diameter

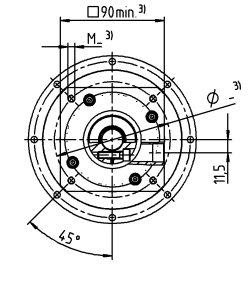
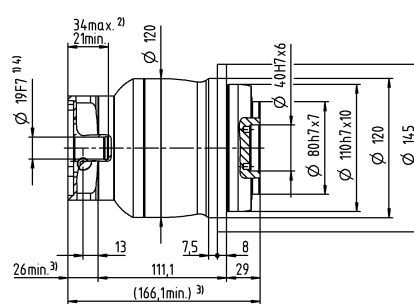
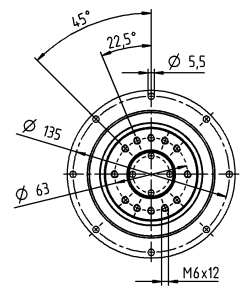

up to 28⁴⁾ (H)
clamping hub
diameter

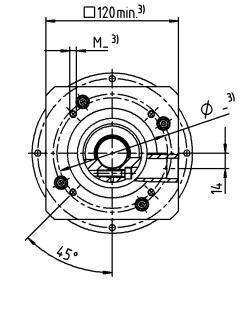
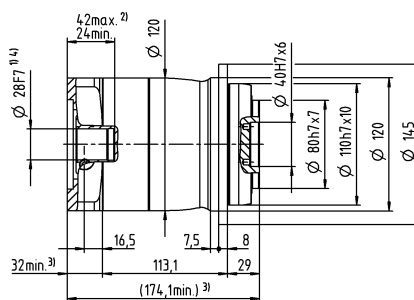
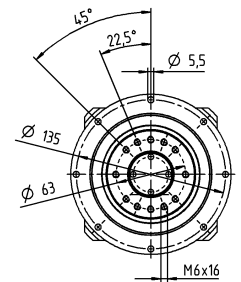

Motor shaft diameter [mm]

Non-tolerated dimensions are nominal dimensions

¹⁾ Check motor shaft fit

²⁾ Min. / Max. permissible motor shaft length

Longer motor shafts are possible, please contact alpha

³⁾ The dimensions depend on the motor

⁴⁾ Smaller motor shaft diameter is compensated

by a bushing with a minimum wall thickness of 1 mm

⁵⁾ Standard clamping hub diameter

NPR 015 MF 1-stage

			1-stage							
Ratio	i		3	4	5	7	8	10		
Max. torque ^{a) b) e)}	T_{2a}	Nm	51	56	64	64	56	56		
		in.lb	451	496	566	566	496	496		
Max. acceleration torque ^{e)} (max. 1000 cycles per hour)	T_{2B}	Nm	32	35	40	40	35	35		
		in.lb	283	310	354	354	310	310		
Emergency stop torque ^{a) b) e)} (permitted 1000 times during the service life of the gearbox)	T_{2Not}	Nm	80	80	80	80	80	80		
		in.lb	708	708	708	708	708	708		
Permitted average input speed ^{d)} (at T_{2a} and 20 °C ambient temperature)	n_{1N}	rpm	2600	2800	2900	3400	3400	3600		
Max. input speed	n_{1Max}	rpm	8000	8000	8000	8000	8000	8000		
Mean no load running torque ^{b)} (at $n_1=3000$ rpm and 20 °C gearbox temperature)	T_{012}	Nm	0.98	0.78	0.66	0.52	0.48	0.42		
		in.lb	8.7	6.9	5.8	4.6	4.2	3.7		
Max. backlash	j_l	arcmin	≤ 8							
Torsional rigidity ^{b)}	C_{i21}	Nm/arcmin	3.3	3.3	3.3	3.3	2.8	2.8		
		in.lb/arcmin	29	29	29	29	25	25		
Max. axial force ^{c)}	F_{2AMax}	N	2400							
		lb _f	540							
Max. lateral force ^{c)}	F_{2QMMax}	N	2800							
		lb _f	630							
Max. tilting moment	M_{2KMMax}	Nm	152							
		in.lb	1345							
Efficiency at full load	η	%	97							
Service life	L_n	h	> 20000							
Weight (incl. standard adapter plate)	m	kg	1.9							
		lb _m	4.2							
Operating noise (at reference ratio and reference speed – ratio-specific values available in cymex [®])	L_{PA}	dB(A)	≤ 59							
Max. permitted housing temperature		°C	+90							
		°F	+194							
Ambient temperature		°C	-15 to +40							
		°F	+5 to +104							
Lubrication			Lubricated for life							
Direction of rotation			In- and output same direction							
Protection class			IP 65							
Elastomer coupling (recommended product type – validate sizing with cymex [®])			ELC-0060BA016.000-X							
Bore diameter of coupling on the application side		mm	X = 012.000 - 032.000							
Mass moment of inertia (relates to the drive) Clamping hub diameter [mm]	A	9	J_1	kgcm ²	0.25	0.19	0.17	0.14	0.14	0.13
				10 ⁻³ in.lb.s ²	0.22	0.17	0.15	0.12	0.12	0.12
	B	11	J_1	kgcm ²	0.26	0.21	0.18	0.16	0.16	0.15
				10 ⁻³ in.lb.s ²	0.23	0.19	0.16	0.14	0.14	0.13
	C	14	J_1	kgcm ²	0.34	0.28	0.26	0.24	0.23	0.23
				10 ⁻³ in.lb.s ²	0.3	0.25	0.23	0.21	0.2	0.2
	D	16	J_1	kgcm ²	0.47	0.41	0.39	0.36	0.36	0.35
				10 ⁻³ in.lb.s ²	0.42	0.36	0.35	0.32	0.32	0.31
	E	19	J_1	kgcm ²	0.55	0.49	0.47	0.45	0.44	0.44
				10 ⁻³ in.lb.s ²	0.49	0.43	0.42	0.4	0.39	0.39

Please use our sizing software cymex[®] for a detailed sizing – www.wittenstein-cymex.com

^{a)} Valid for torque transmission only

^{b)} Valid for standard clamping hub diameter

^{c)} Refers to center of the output shaft or flange

^{d)} Please reduce input speed at higher ambient temperatures

^{e)} Valid for: Smooth shaft

1-stage

Motor shaft diameter [mm]

up to 14⁴⁾ (C)⁵⁾
clamping hub diameter

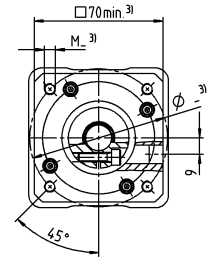
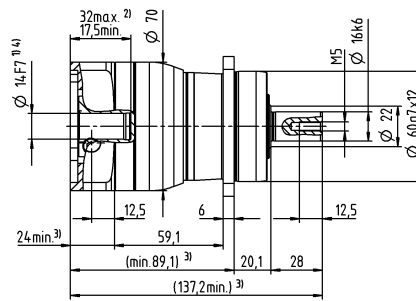
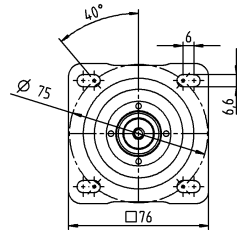

up to 19⁴⁾ (E)
clamping hub diameter

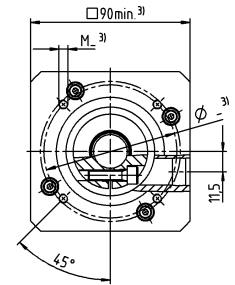
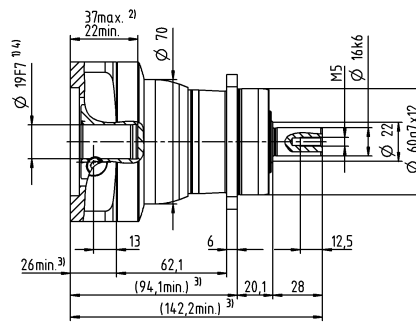
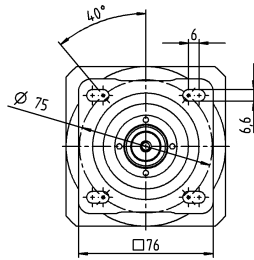

Other output variants

Shaft with key

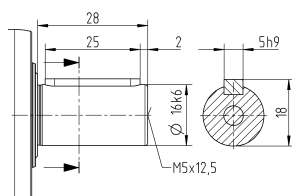

Splined shaft (DIN 5480)

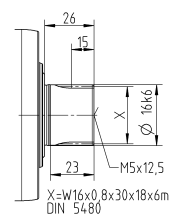

Non-tolerated dimensions are nominal dimensions

¹⁾ Check motor shaft fit

²⁾ Min. / Max. permissible motor shaft length

Longer motor shafts are possible, please contact alpha

³⁾ The dimensions depend on the motor

⁴⁾ Smaller motor shaft diameter is compensated by a bushing with a minimum wall thickness of 1 mm

⁵⁾ Standard clamping hub diameter

NPR 015 MF 2-stage

			2-stage														
Ratio	i		12	15	16	20	25	28	30	32	35	40	50	64	70	100	
Max. torque ^{a) b) e)}	T_{2a}	Nm	51	51	56	56	64	56	51	56	64	56	64	56	64	56	
		in.lb	451	451	496	496	566	496	451	496	566	496	566	496	566	496	566
Max. acceleration torque ^{e)} (max. 1000 cycles per hour)	T_{2B}	Nm	32	32	35	35	40	35	32	35	40	35	40	35	40	35	
		in.lb	283	283	310	310	354	310	283	310	354	310	354	310	354	310	
Emergency stop torque ^{a) b) e)} (permitted 1000 times during the service life of the gearbox)	T_{2Not}	Nm	80	80	80	80	80	80	80	80	80	80	80	80	80	80	
		in.lb	708	708	708	708	708	708	708	708	708	708	708	708	708	708	
Permitted average input speed ^{d)} (at T_{2a} and 20 °C ambient temperature)	n_{1N}	rpm	3800	4000	3800	4000	4000	4300	4600	4400	4300	4600	4600	4400	4600	4600	
Max. input speed	n_{1Max}	rpm	10000	10000	10000	10000	10000	10000	10000	10000	10000	10000	10000	10000	10000	10000	
Mean no load running torque ^{b)} (at $n_1=3000$ rpm and 20 °C gearbox temperature)	T_{012}	Nm	0.34	0.29	0.29	0.25	0.23	0.21	0.21	0.2	0.2	0.19	0.17	0.17	0.16	0.15	
		in.lb	3	2.6	2.6	2.2	2	1.9	1.9	1.8	1.8	1.7	1.5	1.5	1.4	1.3	
Max. backlash	j_l	arcmin	≤ 10														
Torsional rigidity ^{b)}	C_{i21}	Nm/arcmin	3.3	3.3	3.3	3.3	3.3	3.3	3.3	3.3	3.3	3.3	3.3	2.8	3.3	2.8	
		in.lb/arcmin	29	29	29	29	29	29	29	29	29	29	29	25	29	25	
Max. axial force ^{c)}	F_{2AMax}	N	2400														
		lb _f	540														
Max. lateral force ^{c)}	F_{2QMMax}	N	2800														
		lb _f	630														
Max. tilting moment	M_{2KMMax}	Nm	152														
		in.lb	1345														
Efficiency at full load	η	%	95														
Service life	L_n	h	> 20000														
Weight (incl. standard adapter plate)	m	kg	2														
		lb _m	4.4														
Operating noise (at reference ratio and reference speed – ratio-specific values available in cymex [®])	L_{PA}	dB(A)	≤ 58														
Max. permitted housing temperature		°C	+90														
		°F	+194														
Ambient temperature		°C	-15 to +40														
		°F	+5 to +104														
Lubrication			Lubricated for life														
Direction of rotation			In- and output same direction														
Protection class			IP 65														
Elastomer coupling (recommended product type – validate sizing with cymex [®])			ELC-0060BA016.000-X														
Bore diameter of coupling on the application side		mm	X = 012.000 - 032.000														
Mass moment of inertia (relates to the drive) Clamping hub diameter [mm]	Z	8	J_1	kgcm ²	0.04	0.04	0.03	0.03	0.03	0.03	0.03	0.03	0.03	0.02	0.02	0.02	0.02
				10 ⁻³ in.lb.s ²	0.04	0.04	0.03	0.03	0.03	0.03	0.03	0.03	0.03	0.03	0.02	0.02	0.02
	A	9	J_1	kgcm ²	0.04	0.04	0.03	0.03	0.03	0.03	0.03	0.03	0.03	0.02	0.02	0.02	0.02
				10 ⁻³ in.lb.s ²	0.04	0.04	0.03	0.03	0.03	0.03	0.03	0.03	0.03	0.02	0.02	0.02	0.02
	B	11	J_1	kgcm ²	0.06	0.06	0.05	0.05	0.05	0.05	0.05	0.04	0.05	0.04	0.04	0.04	
				10 ⁻³ in.lb.s ²	0.05	0.05	0.04	0.04	0.04	0.04	0.04	0.04	0.04	0.04	0.04	0.04	
	C	14	J_1	kgcm ²	0.14	0.14	0.14	0.13	0.13	0.13	0.14	0.13	0.13	0.13	0.13	0.13	
				10 ⁻³ in.lb.s ²	0.12	0.12	0.12	0.12	0.12	0.12	0.12	0.12	0.12	0.12	0.12	0.12	

Please use our sizing software cymex[®] for a detailed sizing – www.wittenstein-cymex.com

^{a)} Valid for torque transmission only

^{b)} Valid for standard clamping hub diameter

^{c)} Refers to center of the output shaft or flange

^{d)} Please reduce input speed at higher ambient temperatures

^{e)} Valid for: Smooth shaft

2-stage

Motor shaft diameter [mm]

up to 11⁴⁾ (B)⁵⁾
clamping hub diameter

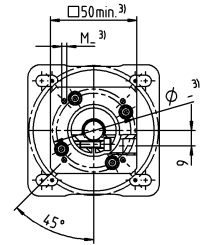
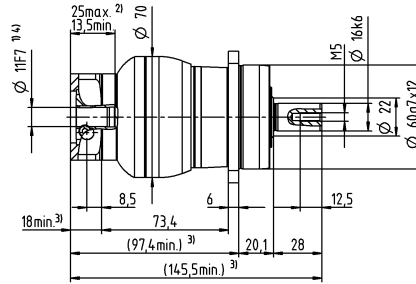
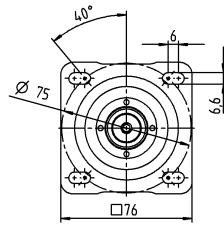

up to 14⁴⁾ (C)
clamping hub diameter

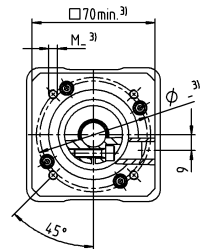
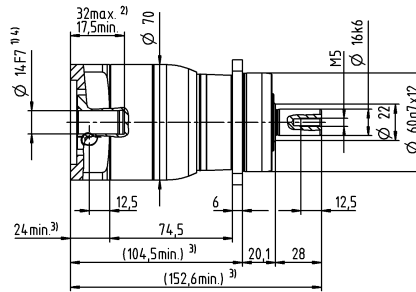
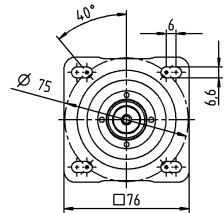

Planetary Gearboxes
Value Line

Other output variants

Shaft with key

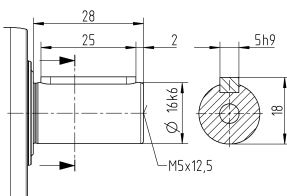

Splined shaft (DIN 5480)

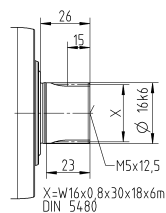

Non-tolerated dimensions are nominal dimensions

¹⁾ Check motor shaft fit

²⁾ Min. / Max. permissible motor shaft length

Longer motor shafts are possible, please contact alpha

³⁾ The dimensions depend on the motor

⁴⁾ Smaller motor shaft diameter is compensated by a bushing with a minimum wall thickness of 1 mm

⁵⁾ Standard clamping hub diameter

NPR 025 MF 1-stage

			1-stage							
Ratio	i		3	4	5	7	8	10		
Max. torque ^{a) b) e)}	T_{2a}	Nm	128	152	160	160	144	144		
		in.lb	1133	1345	1416	1416	1275	1275		
Max. acceleration torque ^{e)} (max. 1000 cycles per hour)	T_{2B}	Nm	80	95	100	100	90	90		
		in.lb	708	841	885	885	797	797		
Emergency stop torque ^{a) b) e)} (permitted 1000 times during the service life of the gearbox)	T_{2Not}	Nm	190	190	190	190	190	190		
		in.lb	1682	1682	1682	1682	1682	1682		
Permitted average input speed ^{d)} (at T_{2N} and 20 °C ambient temperature)	n_{1N}	rpm	2400	2600	2700	3000	3100	3300		
Max. input speed	n_{1Max}	rpm	7000	7000	7000	7000	7000	7000		
Mean no load running torque ^{b)} (at $n_1=3000$ rpm and 20 °C gearbox temperature)	T_{012}	Nm	1.9	1.6	1.4	1.1	1.1	0.96		
		in.lb	17	14	12	9.7	9.7	8.5		
Max. backlash	j_l	arcmin	≤ 8							
Torsional rigidity ^{b)}	C_{i21}	Nm/arcmin	9.5	9.5	9.5	9.5	8.5	8.5		
		in.lb/arcmin	84	84	84	84	75	75		
Max. axial force ^{c)}	F_{2AMax}	N	3350							
		lb _f	754							
Max. lateral force ^{c)}	F_{2QMMax}	N	4200							
		lb _f	945							
Max. tilting moment	M_{2KMMax}	Nm	236							
		in.lb	2089							
Efficiency at full load	η	%	97							
Service life	L_n	h	> 20000							
Weight (incl. standard adapter plate)	m	kg	3.7							
		lb _m	8.2							
Operating noise (at reference ratio and reference speed – ratio-specific values available in cymex [®])	L_{PA}	dB(A)	≤ 61							
Max. permitted housing temperature		°C	+90							
		°F	+194							
Ambient temperature		°C	-15 to +40							
		°F	+5 to +104							
Lubrication			Lubricated for life							
Direction of rotation			In- and output same direction							
Protection class			IP 65							
Elastomer coupling (recommended product type – validate sizing with cymex [®])			ELC-0060BA022.000-X							
Bore diameter of coupling on the application side		mm	X = 012.000 - 032.000							
Mass moment of inertia (relates to the drive) Clamping hub diameter [mm]	C	14	J_1	kgcm ²	0.58	0.47	0.38	0.3	0.28	0.26
				10 ⁻³ in.lb.s ²	0.51	0.42	0.34	0.27	0.25	0.23
	D	16	J_1	kgcm ²	0.73	0.62	0.53	0.43	0.42	0.4
				10 ⁻³ in.lb.s ²	0.65	0.55	0.47	0.38	0.37	0.35
	E	19	J_1	kgcm ²	0.81	0.71	0.61	0.53	0.51	0.49
				10 ⁻³ in.lb.s ²	0.72	0.63	0.54	0.47	0.45	0.43
	G	24	J_1	kgcm ²	1.8	1.7	1.6	1.6	1.5	1.5
				10 ⁻³ in.lb.s ²	1.6	1.5	1.4	1.4	1.3	1.3
	H	28	J_1	kgcm ²	1.6	1.4	1.4	1.3	1.3	1.2
				10 ⁻³ in.lb.s ²	1.4	1.2	1.2	1.2	1.2	1.1

Please use our sizing software cymex[®] for a detailed sizing – www.wittenstein-cymex.com

^{a)} Valid for torque transmission only

^{b)} Valid for standard clamping hub diameter

^{c)} Refers to center of the output shaft or flange

^{d)} Please reduce input speed at higher ambient temperatures

^{e)} Valid for: Smooth shaft

1-stage

up to 19⁴⁾ (E)⁵⁾
clamping hub
diameter

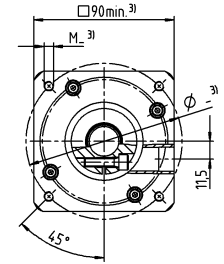
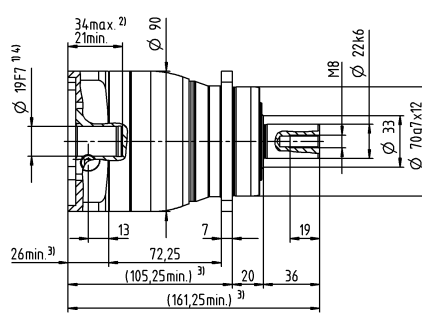
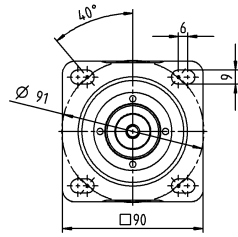

Motor shaft diameter [mm]

up to 28⁴⁾ (H)
clamping hub
diameter

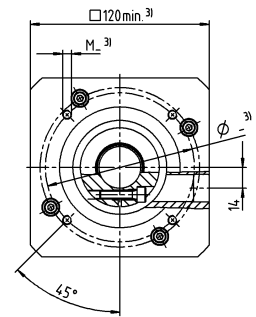
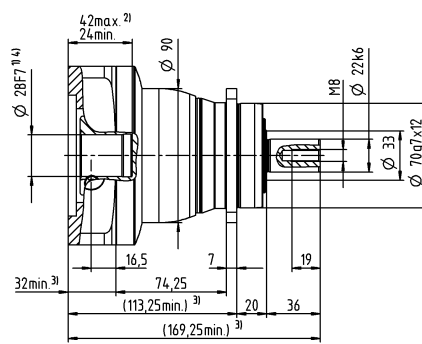
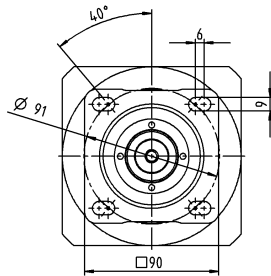

Planetary Gearboxes
Value Line

Other output variants

Shaft with key

Splined shaft (DIN 5480)

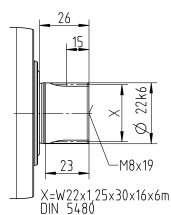
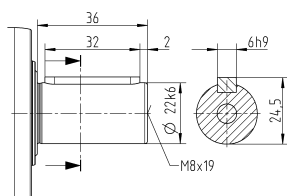

Non-tolerated dimensions are nominal dimensions

¹⁾ Check motor shaft fit

²⁾ Min. / Max. permissible motor shaft length

Longer motor shafts are possible, please contact alpha

³⁾ The dimensions depend on the motor

⁴⁾ Smaller motor shaft diameter is compensated

by a bushing with a minimum wall thickness of 1 mm

⁵⁾ Standard clamping hub diameter

NPR 025 MF 2-stage

			2-stage														
Ratio	i		9	12	15	16	20	25	28	30	32	35	40	50	64	70	100
Max. torque ^{a) b) e)}	T_{2a}	Nm	128	128	128	152	152	160	152	128	144	160	152	160	144	160	144
		in.lb	1133	1133	1133	1345	1345	1416	1345	1133	1275	1416	1345	1416	1275	1416	1275
Max. acceleration torque ^{e)} (max. 1000 cycles per hour)	T_{2B}	Nm	80	80	80	95	95	100	95	80	90	100	95	100	90	100	90
		in.lb	708	708	708	841	841	885	841	708	797	885	841	885	797	885	797
Emergency stop torque ^{a) b) e)} (permitted 1000 times during the service life of the gearbox)	T_{2Not}	Nm	190	190	190	190	190	190	190	190	190	190	190	190	190	190	190
		in.lb	1682	1682	1682	1682	1682	1682	1682	1682	1682	1682	1682	1682	1682	1682	1682
Permitted average input speed ^{d)} (at T_{2N} and 20 °C ambient temperature)	n_{1N}	rpm	2800	3500	3700	3500	3700	3700	4000	4300	4100	4000	4300	4300	4100	4300	4300
Max. input speed	n_{1Max}	rpm	8000	8000	8000	8000	8000	8000	8000	8000	8000	8000	8000	8000	8000	8000	8000
Mean no load running torque ^{b)} (at $n_1=3000$ rpm and 20 °C gearbox temperature)	T_{012}	Nm	0.67	0.55	0.47	0.46	0.4	0.36	0.34	0.33	0.32	0.31	0.29	0.27	0.25	0.25	0.23
		in.lb	5.9	4.9	4.2	4.1	3.5	3.2	3	2.9	2.8	2.7	2.6	2.4	2.2	2.2	2
Max. backlash	j_l	arcmin	≤ 10														
Torsional rigidity ^{b)}	C_{121}	Nm/arcmin	10	10	10	10	10	9.5	10	10	10	9.5	10	9.5	8.5	9.5	8.5
		in.lb/arcmin	89	89	89	89	89	84	89	89	89	84	89	84	75	84	75
Max. axial force ^{c)}	F_{2AMax}	N	3350														
		lb _f	754														
Max. lateral force ^{c)}	F_{2QMMax}	N	4200														
		lb _f	945														
Max. tilting moment	M_{2KMMax}	Nm	236														
		in.lb	2089														
Efficiency at full load	η	%	95														
Service life	L_n	h	> 20000														
Weight (incl. standard adapter plate)	m	kg	4														
		lb _m	8.8														
Operating noise (at reference ratio and reference speed – ratio-specific values available in cymex [®])	L_{PA}	dB(A)	≤ 59														
Max. permitted housing temperature		°C	+90														
		°F	+194														
Ambient temperature		°C	-15 to +40														
		°F	+5 to +104														
Lubrication			Lubricated for life														
Direction of rotation			In- and output same direction														
Protection class			IP 65														
Elastomer coupling (recommended product type – validate sizing with cymex [®])			ELC-0060BA022.000-X														
Bore diameter of coupling on the application side		mm	X = 012.000 - 032.000														
Mass moment of inertia (relates to the drive) Clamping hub diameter [mm]	A	9	J_1	kgcm ²	0.26	0.22	0.21	0.21	0.2	0.2	0.19	0.19	0.19	0.19	0.19	0.19	0.19
				10 ⁻³ in.lb.s ²	0.23	0.19	0.19	0.19	0.18	0.18	0.17	0.17	0.17	0.17	0.17	0.17	0.17
	B	11	J_1	kgcm ²	0.28	0.24	0.23	0.23	0.22	0.22	0.21	0.21	0.21	0.21	0.21	0.21	0.21
				10 ⁻³ in.lb.s ²	0.25	0.21	0.2	0.2	0.19	0.19	0.19	0.19	0.19	0.19	0.19	0.19	0.19
	C	14	J_1	kgcm ²	0.35	0.31	0.3	0.3	0.3	0.29	0.29	0.28	0.28	0.28	0.28	0.28	0.28
				10 ⁻³ in.lb.s ²	0.31	0.27	0.27	0.27	0.27	0.26	0.26	0.25	0.25	0.25	0.25	0.25	0.25
	D	16	J_1	kgcm ²	0.48	0.44	0.43	0.43	0.42	0.42	0.41	0.41	0.41	0.41	0.41	0.41	0.41
				10 ⁻³ in.lb.s ²	0.42	0.39	0.38	0.38	0.37	0.37	0.36	0.36	0.36	0.36	0.36	0.36	0.36
	E	19	J_1	kgcm ²	0.56	0.52	0.51	0.52	0.51	0.5	0.5	0.5	0.5	0.5	0.49	0.49	0.49
				10 ⁻³ in.lb.s ²	0.5	0.46	0.45	0.46	0.45	0.44	0.44	0.44	0.44	0.44	0.43	0.43	0.43

Please use our sizing software cymex[®] for a detailed sizing – www.wittenstein-cymex.com

^{a)} Valid for torque transmission only

^{b)} Valid for standard clamping hub diameter

^{c)} Refers to center of the output shaft or flange

^{d)} Please reduce input speed at higher ambient temperatures

^{e)} Valid for: Smooth shaft

2-stage

Motor shaft diameter [mm]

up to 14⁴⁾ (C)⁵⁾
clamping hub diameter

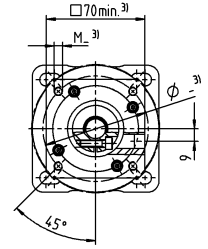
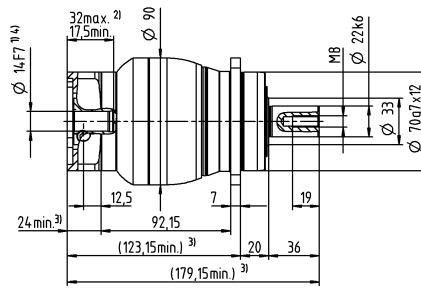
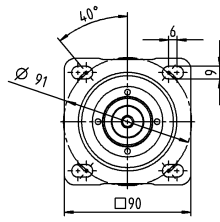

up to 19⁴⁾ (E)
clamping hub diameter

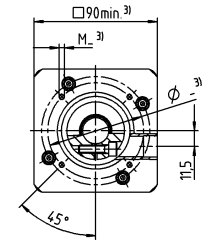
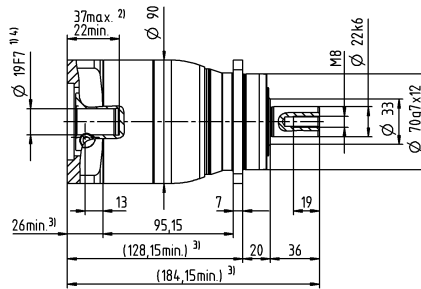
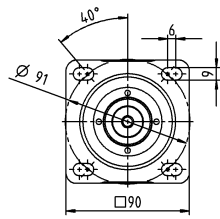

Planetary Gearboxes
Value Line

Other output variants

Shaft with key

Splined shaft (DIN 5480)

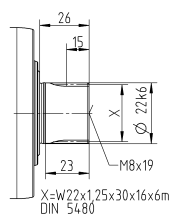
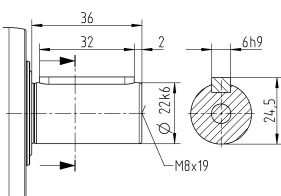

Non-tolerated dimensions are nominal dimensions

¹⁾ Check motor shaft fit

²⁾ Min. / Max. permissible motor shaft length

Longer motor shafts are possible, please contact alpha

³⁾ The dimensions depend on the motor

⁴⁾ Smaller motor shaft diameter is compensated by a bushing with a minimum wall thickness of 1 mm

⁵⁾ Standard clamping hub diameter

NPR 035 MF 1-stage

			1-stage							
Ratio	i		3	4	5	7	8	10		
Max. torque ^{a) b) e)}	T_{2a}	Nm	320	408	400	400	352	352		
		in.lb	2832	3611	3540	3540	3115	3115		
Max. acceleration torque ^{e)} (max. 1000 cycles per hour)	T_{2B}	Nm	200	255	250	250	220	220		
		in.lb	1770	2257	2213	2213	1947	1947		
Emergency stop torque ^{a) b) e)} (permitted 1000 times during the service life of the gearbox)	T_{2Not}	Nm	500	500	500	500	500	500		
		in.lb	4425	4425	4425	4425	4425	4425		
Permitted average input speed ^{d)} (at T_{2a} and 20 °C ambient temperature)	n_{1N}	rpm	1800	2000	2000	2300	2400	2500		
Max. input speed	n_{1Max}	rpm	6000	6000	6000	6000	6000	6000		
Mean no load running torque ^{b)} (at $n_1=3000$ rpm and 20 °C gearbox temperature)	T_{012}	Nm	3.5	2.8	2.4	1.9	1.8	1.6		
		in.lb	31	25	21	17	16	14		
Max. backlash	j_l	arcmin	≤ 8							
Torsional rigidity ^{b)}	C_{t21}	Nm/arcmin	25	25	25	25	22	22		
		in.lb/arcmin	221	221	221	221	195	195		
Max. axial force ^{c)}	F_{2AMax}	N	5650							
		lb _f	1271							
Max. lateral force ^{c)}	F_{2QMMax}	N	6600							
		lb _f	1485							
Max. tilting moment	M_{2KMMax}	Nm	487							
		in.lb	4310							
Efficiency at full load	η	%	97							
Service life	L_n	h	> 20000							
Weight (incl. standard adapter plate)	m	kg	8.6							
		lb _m	19							
Operating noise (at reference ratio and reference speed – ratio-specific values available in cymex [®])	L_{PA}	dB(A)	≤ 65							
Max. permitted housing temperature		°C	+90							
		°F	+194							
Ambient temperature		°C	-15 to +40							
		°F	+5 to +104							
Lubrication			Lubricated for life							
Direction of rotation			In- and output same direction							
Protection class			IP 65							
Elastomer coupling (recommended product type – validate sizing with cymex [®])			ELC-0150BA032.000-X							
Bore diameter of coupling on the application side		mm	X = 019.000 - 036.000							
Mass moment of inertia (relates to the drive) Clamping hub diameter [mm]	E	19	J_1	kgcm ²	2.5	1.7	1.3	1	0.94	0.87
				10 ⁻³ in.lb.s ²	2.2	1.5	1.2	0.89	0.83	0.77
	G	24	J_1	kgcm ²	3.3	2.4	2.1	1.8	1.7	1.6
				10 ⁻³ in.lb.s ²	2.9	2.1	1.9	1.6	1.5	1.4
	H	28	J_1	kgcm ²	3	2.2	1.8	1.5	1.4	1.4
				10 ⁻³ in.lb.s ²	2.7	1.9	1.6	1.3	1.2	1.2
	I	32	J_1	kgcm ²	7.1	6.2	5.9	5.6	5.5	5.4
				10 ⁻³ in.lb.s ²	6.3	5.5	5.2	5	4.9	4.8
	K	38	J_1	kgcm ²	8.3	7.4	7.1	6.7	6.6	6.6
				10 ⁻³ in.lb.s ²	7.3	6.5	6.3	5.9	5.8	5.8

Please use our sizing software cymex[®] for a detailed sizing – www.wittenstein-cymex.com

^{a)} Valid for torque transmission only

^{b)} Valid for standard clamping hub diameter

^{c)} Refers to center of the output shaft or flange

^{d)} Please reduce input speed at higher ambient temperatures

^{e)} Valid for: Smooth shaft

1-stage

Motor shaft diameter [mm]

up to 24/28⁴⁾
(G⁵⁾/H)
clamping hub diameter

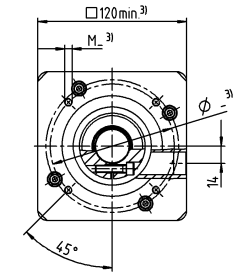
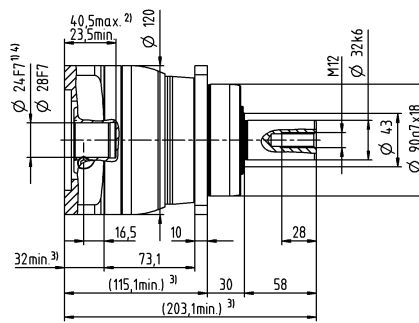
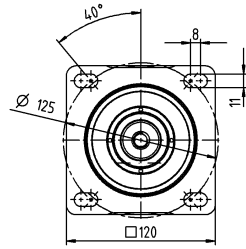

up to 38⁴⁾ (K)
clamping hub diameter

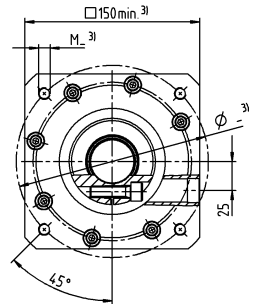
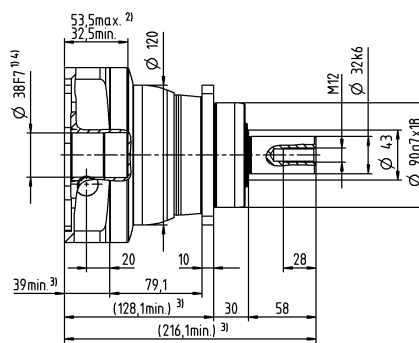
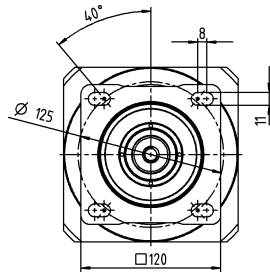

Other output variants

Shaft with key

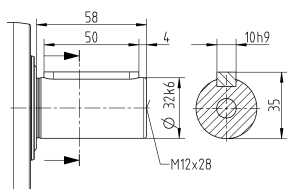

Splined shaft (DIN 5480)

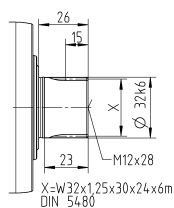

Non-tolerated dimensions are nominal dimensions

¹⁾ Check motor shaft fit

²⁾ Min. / Max. permissible motor shaft length

Longer motor shafts are possible, please contact alpha

³⁾ The dimensions depend on the motor

⁴⁾ Smaller motor shaft diameter is compensated

by a bushing with a minimum wall thickness of 1 mm

⁵⁾ Standard clamping hub diameter

NPR 035 MF 2-stage

			2-stage																
Ratio	i		9	12	15	16	20	25	28	30	32	35	40	50	64	70	100		
Max. torque ^{a) b) e)}	T_{2a}	Nm	320	320	320	408	408	400	408	320	408	400	408	400	352	400	352		
		in.lb	2832	2832	2832	3611	3611	3540	3611	2832	3611	3540	3611	3540	3115	3540	3115		
Max. acceleration torque ^{e)} (max. 1000 cycles per hour)	T_{2B}	Nm	200	200	200	255	255	250	255	200	255	250	255	250	220	250	220		
		in.lb	1770	1770	1770	2257	2257	2213	2257	1770	2257	2213	2257	2213	1947	2213	1947		
Emergency stop torque ^{a) b) e)} (permitted 1000 times during the service life of the gearbox)	T_{2Not}	Nm	500	500	500	500	500	500	500	500	500	500	500	500	500	500	500		
		in.lb	4425	4425	4425	4425	4425	4425	4425	4425	4425	4425	4425	4425	4425	4425	4425		
Permitted average input speed ^{d)} (at T_{2a} and 20 °C ambient temperature)	n_{1N}	rpm	2600	3300	3400	3300	3400	3400	3600	3900	3700	3600	3900	3900	3700	3900	3900		
Max. input speed	n_{1Max}	rpm	7000	7000	7000	7000	7000	7000	7000	7000	7000	7000	7000	7000	7000	7000	7000		
Mean no load running torque ^{b)} (at $n_1=3000$ rpm and 20 °C gearbox temperature)	T_{012}	Nm	1.7	1.4	1.2	1.2	1.1	1	0.93	0.88	0.88	0.87	0.81	0.77	0.75	0.72	0.68		
		in.lb	15	12	11	11	9.7	8.9	8.2	7.8	7.8	7.7	7.2	6.8	6.6	6.4	6		
Max. backlash	j_l	arcmin	≤ 10																
Torsional rigidity ^{b)}	C_{i21}	Nm/arcmin	25	25	25	25	25	25	25	25	25	25	25	25	22	25	22		
		in.lb/arcmin	221	221	221	221	221	221	221	221	221	221	221	221	195	221	195		
Max. axial force ^{c)}	F_{2AMax}	N	5650																
		lb _f	1271																
Max. lateral force ^{c)}	F_{2QMMax}	N	6600																
		lb _f	1485																
Max. tilting moment	M_{2KMMax}	Nm	487																
		in.lb	4310																
Efficiency at full load	η	%	95																
Service life	L_n	h	> 20000																
Weight (incl. standard adapter plate)	m	kg	9																
		lb _m	20																
Operating noise (at reference ratio and reference speed – ratio-specific values available in cymex [®])	L_{PA}	dB(A)	≤ 61																
Max. permitted housing temperature		°C	+90																
		°F	+194																
Ambient temperature		°C	-15 to +40																
		°F	+5 to +104																
Lubrication			Lubricated for life																
Direction of rotation			In- and output same direction																
Protection class			IP 65																
Elastomer coupling (recommended product type – validate sizing with cymex [®])			ELC-0150BA032.000-X																
Bore diameter of coupling on the application side		mm	X = 019.000 - 036.000																
Mass moment of inertia (relates to the drive) Clamping hub diameter [mm]	C	14	J_1	kgcm ²	0.6	0.59	0.6	0.43	0.42	0.36	0.37	0.52	0.38	0.32	0.36	0.31	0.26	0.27	0.24
				10 ⁻³ in.lb.s ²	0.53	0.52	0.53	0.38	0.37	0.32	0.33	0.46	0.34	0.28	0.32	0.27	0.23	0.24	0.21
	D	16	J_1	kgcm ²	0.75	0.74	0.74	0.58	0.57	0.5	0.5	0.67	0.52	0.45	0.51	0.46	0.4	0.41	0.39
				10 ⁻³ in.lb.s ²	0.66	0.65	0.65	0.51	0.5	0.44	0.44	0.59	0.46	0.4	0.45	0.41	0.35	0.36	0.35
	E	19	J_1	kgcm ²	0.84	0.83	0.83	0.66	0.65	0.59	0.6	0.75	0.61	0.55	0.6	0.54	0.49	0.5	0.48
				10 ⁻³ in.lb.s ²	0.74	0.73	0.73	0.58	0.58	0.52	0.53	0.66	0.54	0.49	0.53	0.48	0.43	0.44	0.42
	G	24	J_1	kgcm ²	1.9	1.9	1.9	1.7	1.7	1.6	1.6	1.8	1.6	1.6	1.6	1.6	1.5	1.5	1.5
				10 ⁻³ in.lb.s ²	1.7	1.6	1.7	1.5	1.5	1.4	1.5	1.6	1.5	1.4	1.4	1.4	1.4	1.3	1.4
	H	28	J_1	kgcm ²	1.6	1.6	1.6	1.4	1.4	1.3	1.3	1.5	1.4	1.3	1.3	1.3	1.2	1.2	1.2
				10 ⁻³ in.lb.s ²	1.4	1.4	1.4	1.2	1.2	1.2	1.2	1.3	1.2	1.1	1.2	1.1	1.1	1.1	1.1

Please use our sizing software cymex[®] for a detailed sizing – www.wittenstein-cymex.com

^{a)} Valid for torque transmission only

^{b)} Valid for standard clamping hub diameter

^{c)} Refers to center of the output shaft or flange

^{d)} Please reduce input speed at higher ambient temperatures

^{e)} Valid for: Smooth shaft

2-stage

up to 19⁴⁾ (E)⁵⁾
clamping hub
diameter

Motor shaft diameter [mm]

up to 28⁴⁾ (H)
clamping hub
diameter

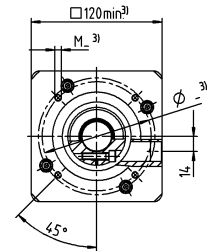
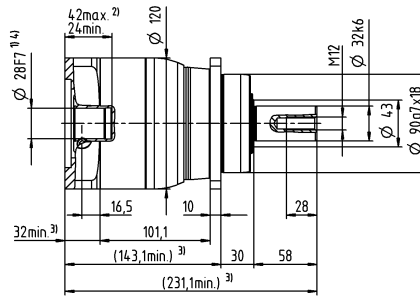
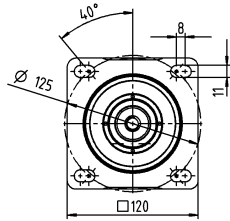
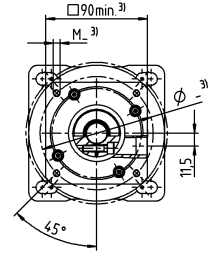
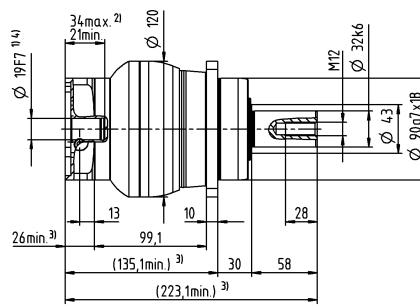
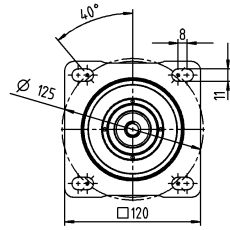

Planetary Gearboxes
Value Line

Other output variants

Shaft with key

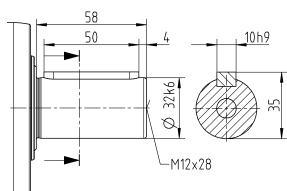

Splined shaft (DIN 5480)

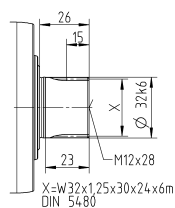

Non-tolerated dimensions are nominal dimensions

¹⁾ Check motor shaft fit

²⁾ Min. / Max. permissible motor shaft length

Longer motor shafts are possible, please contact alpha

³⁾ The dimensions depend on the motor

⁴⁾ Smaller motor shaft diameter is compensated

by a bushing with a minimum wall thickness of 1 mm

⁵⁾ Standard clamping hub diameter

NPR 045 MF 1-/2-stage

			1-stage			2-stage						
Ratio	i		5	8	10	25	32	50	64	100		
Max. torque ^{a) b) e)}	T_{2a}	Nm	800	640	640	700	640	700	640	640		
		in.lb	7081	5665	5665	6196	5665	6196	5665	5665		
Max. acceleration torque ^{e)} (max. 1000 cycles per hour)	T_{2B}	Nm	500	400	400	500	400	500	400	400		
		in.lb	4425	3540	3540	4425	3540	4425	3540	3540		
Emergency stop torque ^{a) b) e)} (permitted 1000 times during the service life of the gearbox)	T_{2Not}	Nm	1000	1000	1000	1000	1000	1000	1000	1000		
		in.lb	8851	8851	8851	8851	8851	8851	8851	8851		
Permitted average input speed ^{d)} (at T_{2a} and 20 °C ambient temperature)	n_{1N}	rpm	1600	1800	1900	2600	2500	3000	2900	3000		
Max. input speed	n_{1Max}	rpm	4000	4000	4000	6000	6000	6000	6000	6000		
Mean no load running torque ^{b)} (at $n_i=3000$ rpm and 20 °C gearbox temperature)	T_{012}	Nm	4.6	3.1	2.6	1.6	1.5	1.2	1.1	0.97		
		in.lb	41	27	23	14	13	11	9.7	8.6		
Max. backlash	j_l	arcmin	≤ 8			≤ 10						
Torsional rigidity ^{b)}	C_{i21}	Nm/arcmin	55	44	44	55	44	55	44	44		
		in.lb/arcmin	487	389	389	487	389	487	389	389		
Max. axial force ^{c)}	F_{2AMax}	N	9870			9870						
		lb _f	2221			2221						
Max. lateral force ^{c)}	F_{2QMMax}	N	9900			9900						
		lb _f	2228			2228						
Max. tilting moment	M_{2KMMax}	Nm	952			952						
		in.lb	8426			8426						
Efficiency at full load	η	%	97			95						
Service life	L_n	h	> 20000			> 20000						
Weight (incl. standard adapter plate)	m	kg	19			20						
		lb _m	42			44						
Operating noise (at reference ratio and reference speed – ratio-specific values available in cymex [®])	L_{PA}	dB(A)	≤ 68			≤ 65						
Max. permitted housing temperature		°C	+90			+90						
		°F	+194			+194						
Ambient temperature		°C	-15 to +40			-15 to +40						
		°F	+5 to +104			+5 to +104						
Lubrication			Lubricated for life									
Direction of rotation			In- and output same direction									
Protection class			IP 65									
Elastomer coupling (recommended product type – validate sizing with cymex [®])			ELC-0300BA040.000-X									
Bore diameter of coupling on the application side		mm	X = 020.000 - 045.000									
Mass moment of inertia (relates to the drive) Clamping hub diameter [mm]	E	19	J_i	kgcm ²	-	-	-	1.2	1.1	1	0.88	0.82
				10 ⁻³ in.lb.s ²	-	-	-	1.1	0.97	0.89	0.78	0.73
	G	24	J_i	kgcm ²	-	-	-	2	1.9	1.8	1.7	1.6
				10 ⁻³ in.lb.s ²	-	-	-	1.8	1.7	1.6	1.5	1.4
	H	28	J_i	kgcm ²	-	-	-	1.7	1.6	1.5	1.4	1.3
				10 ⁻³ in.lb.s ²	-	-	-	1.5	1.4	1.3	1.2	1.2
	I	32	J_i	kgcm ²	-	-	-	5.8	5.7	5.6	5.4	5.4
				10 ⁻³ in.lb.s ²	-	-	-	5.1	5	5	4.8	4.8
	K	38	J_i	kgcm ²	8.7	7.3	7.2	7	6.9	6.8	6.6	6.5
				10 ⁻³ in.lb.s ²	7.7	6.5	6.4	6.2	6.1	6	5.8	5.8

Please use our sizing software cymex[®] for a detailed sizing – www.wittenstein-cymex.com

^{a)} Valid for torque transmission only

^{b)} Valid for standard clamping hub diameter

^{c)} Refers to center of the output shaft or flange

^{d)} Please reduce input speed at higher ambient temperatures

^{e)} Valid for: Smooth shaft

1-stage

up to 38⁴⁾ (K)⁵⁾
clamping hub
diameter

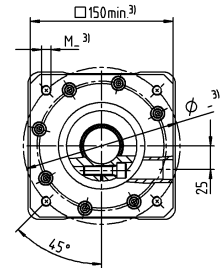
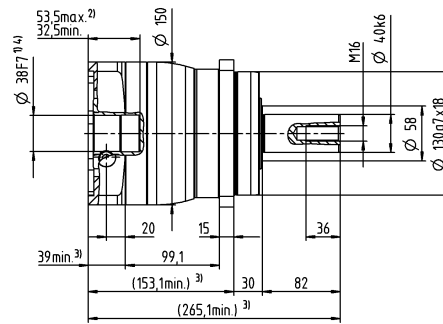
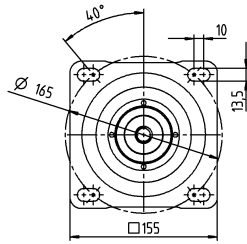

2-stage

up to 28⁴⁾ (H)⁵⁾
clamping hub
diameter

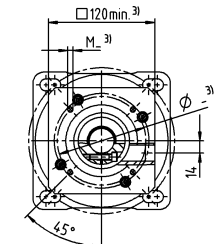
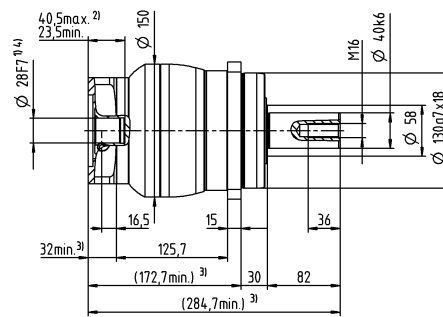
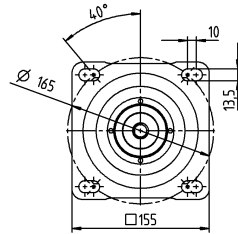

Motor shaft diameter [mm]

up to 38⁴⁾ (K)
clamping hub
diameter

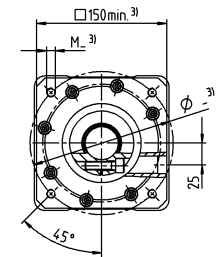
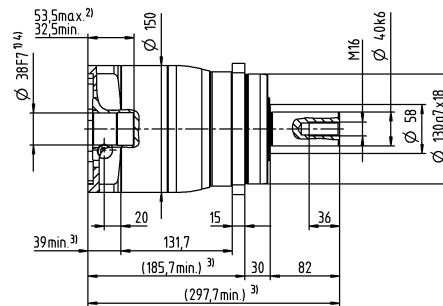
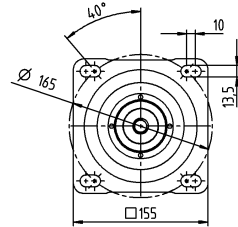

Other output variants

Shaft with key

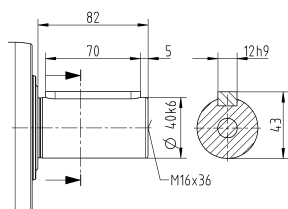

Splined shaft (DIN 5480)

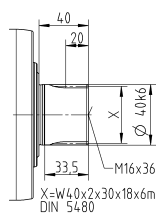

Non-tolerated dimensions are nominal dimensions

¹⁾ Check motor shaft fit

²⁾ Min. / Max. permissible motor shaft length

Longer motor shafts are possible, please contact alpha

³⁾ The dimensions depend on the motor

⁴⁾ Smaller motor shaft diameter is compensated

by a bushing with a minimum wall thickness of 1 mm

⁵⁾ Standard clamping hub diameter

NPR 015 MA 1-/2-stage

			1-stage		2-stage							
Ratio	i		3	4	12	15	16	20	28	30	40	
Max. torque ^{a) b) e)}	T_{2a}	Nm	80	67	62	67	67	67	67	62	67	
		in.lb	708	593	549	593	593	593	593	593	549	593
Max. acceleration torque ^{e)} (max. 1000 cycles per hour)	T_{2B}	Nm	55	42	39	42	42	42	42	39	42	
		in.lb	487	372	345	372	372	372	372	372	345	372
Emergency stop torque ^{a) b) e)} (permitted 1000 times during the service life of the gearbox)	T_{2Not}	Nm	80	80	80	80	80	80	80	80	80	
		in.lb	708	708	708	708	708	708	708	708	708	708
Permitted average input speed ^{d)} (at T_{2N} and 20 °C ambient temperature)	n_{1N}	rpm	2600	2800	3800	4000	3800	4000	4300	4600	4600	
Max. input speed	n_{1Max}	rpm	8000	8000	10000	10000	10000	10000	10000	10000	10000	
Mean no load running torque ^{b)} (at $n_1=3000$ rpm and 20 °C gearbox temperature)	T_{012}	Nm	0.98	0.78	0.34	0.29	0.29	0.25	0.21	0.21	0.19	
		in.lb	8.7	6.9	3	2.6	2.6	2.2	1.9	1.9	1.7	
Max. backlash	j_l	arcmin	≤ 8		≤ 10							
Torsional rigidity ^{b)}	C_{i21}	Nm/arcmin	4	4	4	4	4	4	4	4	4	
		in.lb/arcmin	35	35	35	35	35	35	35	35	35	
Max. axial force ^{c)}	F_{2AMax}	N	2400		2400							
		lb _f	540		540							
Max. lateral force ^{c)}	F_{2QMMax}	N	2800		2800							
		lb _f	630		630							
Max. tilting moment	M_{2KMMax}	Nm	152		152							
		in.lb	1345		1345							
Efficiency at full load	η	%	97		95							
Service life	L_h	h	> 20000		> 20000							
Weight (incl. standard adapter plate)	m	kg	1.9		2							
		lb _m	4.2		4.4							
Operating noise (at reference ratio and reference speed – ratio-specific values available in cymex®)	L_{PA}	dB(A)	≤ 59		≤ 58							
		°C	+90		+90							
Max. permitted housing temperature		°F	+194		+194							
		°C	-15 to +40		-15 to +40							
Ambient temperature		°F	+5 to +104		+5 to +104							
Lubrication			Lubricated for life									
Direction of rotation			In- and output same direction									
Protection class			IP 65									
Elastomer coupling (recommended product type – validate sizing with cymex®)			ELC-0060BA016.000-X									
Bore diameter of coupling on the application side		mm	X = 012.000 - 032.000									
Mass moment of inertia (relates to the drive) Clamping hub diameter [mm]	Z	8	J_1	kgcm ²	-	-	0.04	0.04	0.03	0.03	0.03	0.03
				10 ⁻³ in.lb.s ²	-	-	0.04	0.04	0.03	0.03	0.03	0.03
	A	9	J_1	kgcm ²	0.25	0.19	0.04	0.04	0.03	0.03	0.03	0.03
				10 ⁻³ in.lb.s ²	0.22	0.17	0.04	0.04	0.03	0.03	0.03	0.03
	B	11	J_1	kgcm ²	0.26	0.21	0.06	0.06	0.05	0.05	0.05	0.05
				10 ⁻³ in.lb.s ²	0.23	0.19	0.05	0.05	0.04	0.04	0.04	0.04
	C	14	J_1	kgcm ²	0.34	0.28	0.14	0.14	0.14	0.13	0.13	0.14
				10 ⁻³ in.lb.s ²	0.3	0.25	0.12	0.12	0.12	0.12	0.12	0.12
	D	16	J_1	kgcm ²	0.47	0.41	-	-	-	-	-	-
				10 ⁻³ in.lb.s ²	0.42	0.36	-	-	-	-	-	-
	E	19	J_1	kgcm ²	0.55	0.49	-	-	-	-	-	-
				10 ⁻³ in.lb.s ²	0.49	0.43	-	-	-	-	-	-

Please use our sizing software cymex® for a detailed sizing – www.wittenstein-cymex.com

^{a)} Valid for torque transmission only

^{b)} Valid for standard clamping hub diameter

^{c)} Refers to center of the output shaft or flange

^{d)} Please reduce input speed at higher ambient temperatures

^{e)} Valid for: Smooth shaft

1-stage

up to 14⁴⁾ (C)⁵⁾
clamping hub diameter

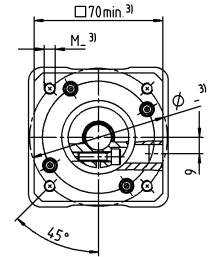
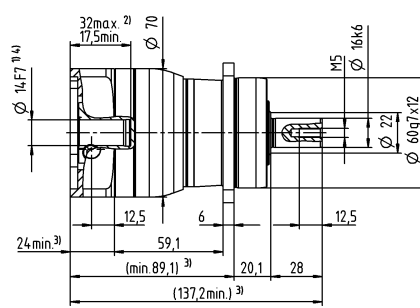
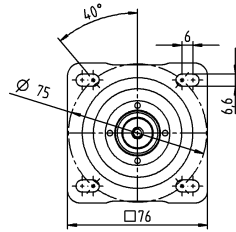

up to 19⁴⁾ (E)
clamping hub diameter

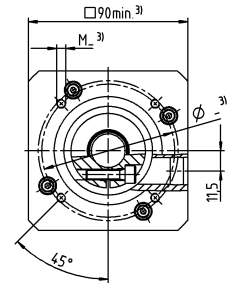
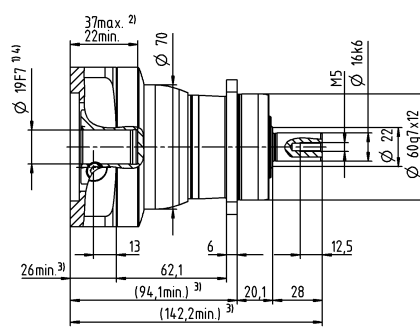
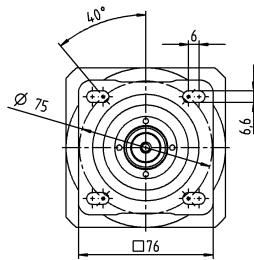

2-stage

up to 11⁴⁾ (B)⁵⁾
clamping hub diameter

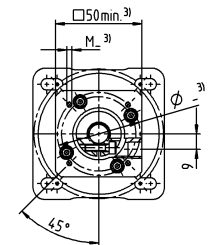
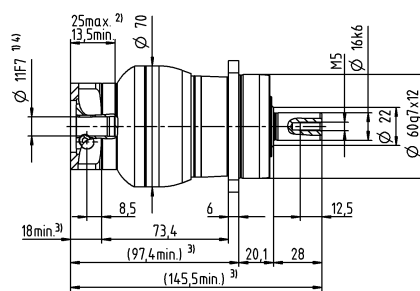
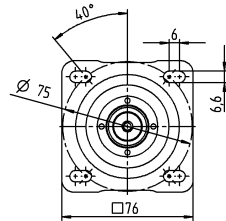

up to 14⁴⁾ (C)
clamping hub diameter

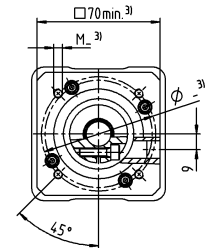
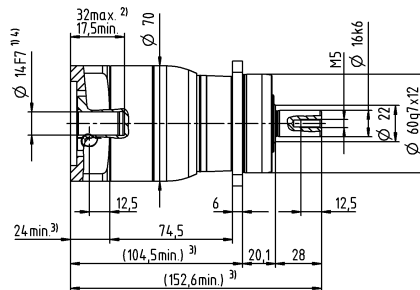
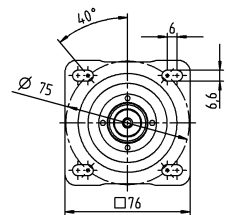

Motor shaft diameter [mm]

Other output variants

Shaft with key

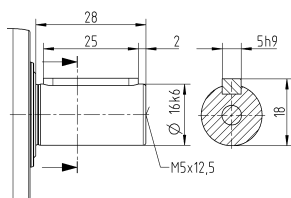

Splined shaft (DIN 5480)

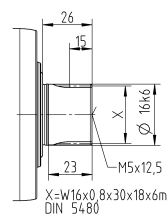

Non-tolerated dimensions are nominal dimensions

¹⁾ Check motor shaft fit

²⁾ Min. / Max. permissible motor shaft length

Longer motor shafts are possible, please contact alpha

³⁾ The dimensions depend on the motor

⁴⁾ Smaller motor shaft diameter is compensated

by a bushing with a minimum wall thickness of 1 mm

⁵⁾ Standard clamping hub diameter

NPR 025 MA 1-/2-stage

			1-stage		2-stage								
Ratio	i		3	4	9	12	15	16	20	28	30	40	
Max. torque ^{a) b) e)}	T_{2a}	Nm	185	185	185	185	185	185	185	185	168	185	
		in.lb	1637	1637	1637	1637	1637	1637	1637	1637	1637	1487	1637
Max. acceleration torque ^{e)} (max. 1000 cycles per hour)	T_{2B}	Nm	125	115	125	125	120	115	115	115	105	115	
		in.lb	1106	1018	1106	1106	1062	1018	1018	1018	929	1018	
Emergency stop torque ^{a) b) e)} (permitted 1000 times during the service life of the gearbox)	T_{2Not}	Nm	190	190	190	190	190	190	190	190	190	190	
		in.lb	1682	1682	1682	1682	1682	1682	1682	1682	1682	1682	
Permitted average input speed ^{d)} (at T_{2m} and 20 °C ambient temperature)	n_{1N}	rpm	2400	2600	2800	3500	3700	3500	3700	4000	4300	4300	
Max. input speed	n_{1Max}	rpm	7000	7000	8000	8000	8000	8000	8000	8000	8000	8000	
Mean no load running torque ^{b)} (at $n_1=3000$ rpm and 20 °C gearbox temperature)	T_{012}	Nm	1.8	1.5	0.67	0.55	0.47	0.46	0.4	0.34	0.33	0.29	
		in.lb	16	13	5.9	4.9	4.2	4.1	3.5	3	2.9	2.6	
Max. backlash	j_l	arcmin	≤ 8		≤ 10								
Torsional rigidity ^{b)}	C_{i21}	Nm/arcmin	12	12	12	12	12	12	12	12	12	12	
		in.lb/arcmin	106	106	106	106	106	106	106	106	106	106	
Max. axial force ^{c)}	F_{2AMax}	N	3350		3350								
		lb _f	754		754								
Max. lateral force ^{c)}	F_{2QMMax}	N	4200		4200								
		lb _f	945		945								
Max. tilting moment	M_{2KMMax}	Nm	236		236								
		in.lb	2089		2089								
Efficiency at full load	η	%	97		95								
Service life	L_n	h	> 20000		> 20000								
Weight (incl. standard adapter plate)	m	kg	3.7		4								
		lb _m	8.2		8.8								
Operating noise (at reference ratio and reference speed – ratio-specific values available in cymex®)	L_{PA}	dB(A)	≤ 61		≤ 59								
		°C	+90		+90								
Max. permitted housing temperature		°F	+194		+194								
		°C	-15 to +40		-15 to +40								
Ambient temperature		°F	+5 to +104		+5 to +104								
			Lubricated for life										
Direction of rotation			In- and output same direction										
Protection class			IP 65										
Elastomer coupling (recommended product type – validate sizing with cymex®)			ELC-0060BA022.000-X										
Bore diameter of coupling on the application side		mm	X = 012.000 - 032.000										
Mass moment of inertia (relates to the drive) Clamping hub diameter [mm]	A	9	J_1	kgcm ²	-	-	0.26	0.22	0.21	0.21	0.2	0.19	0.19
				10 ⁻³ in.lb.s ²	-	-	0.23	0.19	0.19	0.19	0.18	0.17	0.17
	B	11	J_1	kgcm ²	-	-	0.28	0.24	0.23	0.23	0.22	0.21	0.21
				10 ⁻³ in.lb.s ²	-	-	0.25	0.21	0.2	0.2	0.19	0.19	0.19
	C	14	J_1	kgcm ²	0.58	0.47	0.35	0.31	0.3	0.3	0.3	0.29	0.28
				10 ⁻³ in.lb.s ²	0.51	0.42	0.31	0.27	0.27	0.27	0.27	0.26	0.25
	D	16	J_1	kgcm ²	0.73	0.62	0.48	0.44	0.43	0.43	0.42	0.41	0.41
				10 ⁻³ in.lb.s ²	0.65	0.55	0.42	0.39	0.38	0.38	0.37	0.36	0.36
	E	19	J_1	kgcm ²	0.81	0.71	0.56	0.52	0.51	0.52	0.51	0.5	0.5
				10 ⁻³ in.lb.s ²	0.72	0.63	0.5	0.46	0.45	0.46	0.45	0.44	0.44
	G	24	J_1	kgcm ²	1.8	1.7	-	-	-	-	-	-	-
				10 ⁻³ in.lb.s ²	1.6	1.5	-	-	-	-	-	-	-
	H	28	J_1	kgcm ²	1.6	1.4	-	-	-	-	-	-	-
				10 ⁻³ in.lb.s ²	1.4	1.2	-	-	-	-	-	-	-

Please use our sizing software cymex® for a detailed sizing – www.wittenstein-cymex.com

^{a)} Valid for torque transmission only

^{b)} Valid for standard clamping hub diameter

^{c)} Refers to center of the output shaft or flange

^{d)} Please reduce input speed at higher ambient temperatures

^{e)} Valid for: Smooth shaft

1-stage

up to 19⁴⁾ (E)⁵⁾
clamping hub diameter

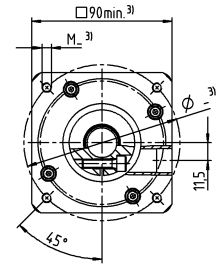
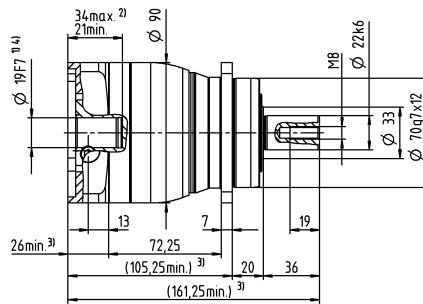
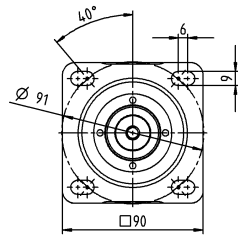

up to 28⁴⁾ (H)
clamping hub diameter

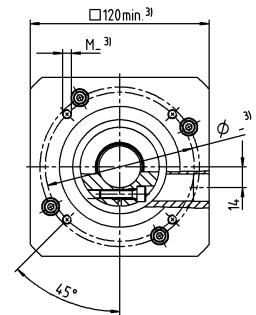
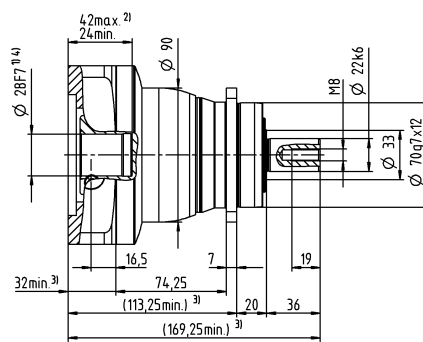
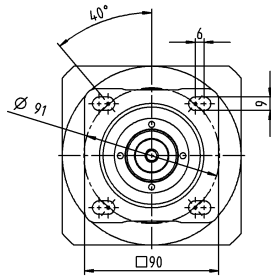

2-stage

up to 14⁴⁾ (C)⁵⁾
clamping hub diameter

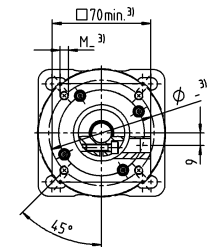
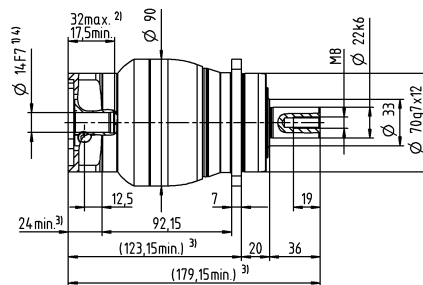
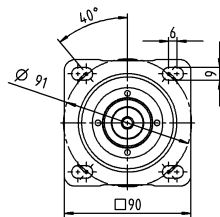

up to 19⁴⁾ (E)
clamping hub diameter

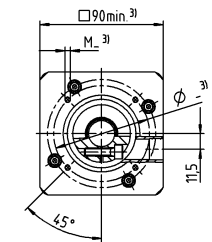
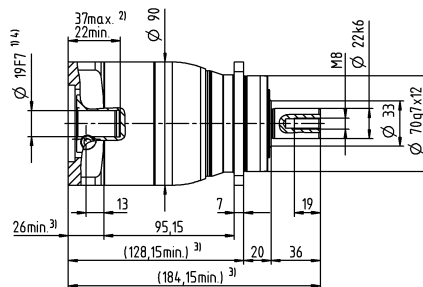
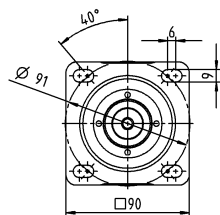

Motor shaft diameter [mm]

Other output variants

Shaft with key

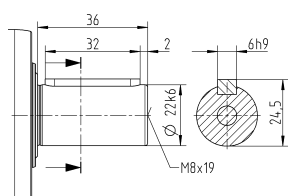

Splined shaft (DIN 5480)

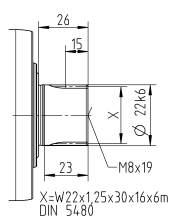

Non-tolerated dimensions are nominal dimensions

¹⁾ Check motor shaft fit

²⁾ Min. / Max. permissible motor shaft length

Longer motor shafts are possible, please contact alpha

³⁾ The dimensions depend on the motor

⁴⁾ Smaller motor shaft diameter is compensated

by a bushing with a minimum wall thickness of 1 mm

⁵⁾ Standard clamping hub diameter

NPR 035 MA 1-/2-stage

			1-stage		2-stage									
Ratio	i		3	4	9	12	15	16	20	28	30	40		
Max. torque ^{a) b) e)}	T_{2a}	Nm	480	480	480	480	480	480	480	480	432	480		
		in.lb	4248	4248	4248	4248	4248	4248	4248	4248	4248	3824	4248	
Max. acceleration torque ^{e)} (max. 1000 cycles per hour)	T_{2B}	Nm	305	305	305	305	300	305	305	305	270	305		
		in.lb	2699	2699	2699	2699	2655	2699	2699	2699	2390	2699		
Emergency stop torque ^{a) b) e)} (permitted 1000 times during the service life of the gearbox)	T_{2Not}	Nm	500	500	500	500	500	500	500	500	500	500		
		in.lb	4425	4425	4425	4425	4425	4425	4425	4425	4425	4425		
Permitted average input speed ^{d)} (at T_{2N} and 20 °C ambient temperature)	n_{1N}	rpm	1800	2000	2600	3300	3400	3300	3400	3600	3900	3900		
Max. input speed	n_{1Max}	rpm	6000	6000	7000	7000	7000	7000	7000	7000	7000	7000		
Mean no load running torque ^{b)} (at $n_1=3000$ rpm and 20 °C gearbox temperature)	T_{012}	Nm	3.5	2.8	1.7	1.4	1.2	1.2	1.1	0.93	0.88	0.81		
		in.lb	31	25	15	12	11	11	9.7	8.2	7.8	7.2		
Max. backlash	j_l	arcmin	≤ 8		≤ 10									
Torsional rigidity ^{b)}	C_{i21}	Nm/arcmin	30	30	30	30	30	30	30	30	30	30		
		in.lb/arcmin	266	266	266	266	266	266	266	266	266	266		
Max. axial force ^{c)}	F_{2AMax}	N	5650		5650									
		lb _f	1271		1271									
Max. lateral force ^{c)}	F_{2QMMax}	N	6600		6600									
		lb _f	1485		1485									
Max. tilting moment	M_{2KMMax}	Nm	487		487									
		in.lb	4310		4310									
Efficiency at full load	η	%	97		95									
Service life	L_n	h	> 20000		> 20000									
Weight (incl. standard adapter plate)	m	kg	8.6		9									
		lb _m	19		20									
Operating noise (at reference ratio and reference speed – ratio-specific values available in cymex®)	L_{PA}	dB(A)	≤ 65		≤ 61									
		°C	+90		+90									
Max. permitted housing temperature		°F	+194		+194									
		°C	-15 to +40		-15 to +40									
Ambient temperature		°F	+5 to +104		+5 to +104									
			Lubricated for life											
Direction of rotation			In- and output same direction											
Protection class			IP 65											
Elastomer coupling (recommended product type – validate sizing with cymex®)			ELC-0150BA032.000-X											
Bore diameter of coupling on the application side		mm	X = 019.000 - 036.000											
Mass moment of inertia (relates to the drive) Clamping hub diameter [mm]	C	14	J_1	kgcm ²	-	-	0.6	0.59	0.6	0.43	0.42	0.37	0.52	0.36
				10 ⁻³ in.lb.s ²	-	-	0.53	0.52	0.53	0.38	0.37	0.33	0.46	0.32
	D	16	J_1	kgcm ²	-	-	0.75	0.74	0.74	0.58	0.57	0.5	0.67	0.51
				10 ⁻³ in.lb.s ²	-	-	0.66	0.65	0.65	0.51	0.5	0.44	0.59	0.45
	E	19	J_1	kgcm ²	2.5	1.7	0.84	0.83	0.83	0.66	0.65	0.6	0.75	0.6
				10 ⁻³ in.lb.s ²	2.2	1.5	0.74	0.73	0.73	0.58	0.58	0.53	0.66	0.53
	G	24	J_1	kgcm ²	3.3	2.4	1.9	1.9	1.9	1.7	1.7	1.6	1.8	1.6
				10 ⁻³ in.lb.s ²	2.9	2.1	1.7	1.6	1.7	1.5	1.5	1.5	1.6	1.4
	H	28	J_1	kgcm ²	3	2.2	1.6	1.6	1.6	1.4	1.4	1.3	1.5	1.3
				10 ⁻³ in.lb.s ²	2.7	1.9	1.4	1.4	1.4	1.2	1.2	1.2	1.3	1.2
	I	32	J_1	kgcm ²	7.1	6.2	-	-	-	-	-	-	-	-
				10 ⁻³ in.lb.s ²	6.3	5.5	-	-	-	-	-	-	-	-
K	38	J_1	kgcm ²	8.3	7.4	-	-	-	-	-	-	-	-	
			10 ⁻³ in.lb.s ²	7.3	6.5	-	-	-	-	-	-	-	-	

Please use our sizing software cymex® for a detailed sizing – www.wittenstein-cymex.com

^{a)} Valid for torque transmission only

^{b)} Valid for standard clamping hub diameter

^{c)} Refers to center of the output shaft or flange

^{d)} Please reduce input speed at higher ambient temperatures

^{e)} Valid for: Smooth shaft

1-stage

up to 24/28⁴⁾
(G⁵⁾/H)
clamping hub
diameter

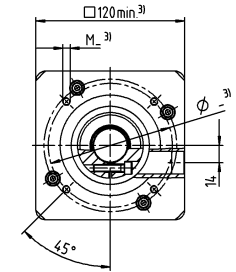
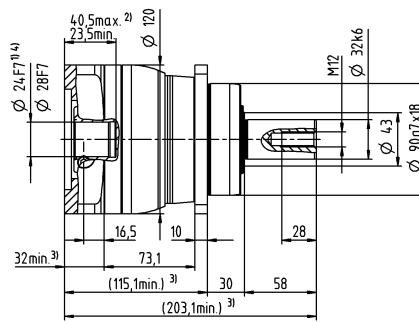
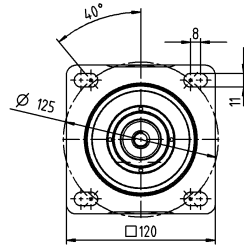

up to 38⁴⁾ (K)
clamping hub
diameter

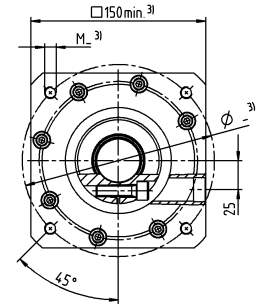
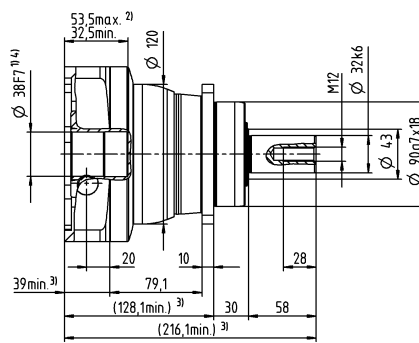
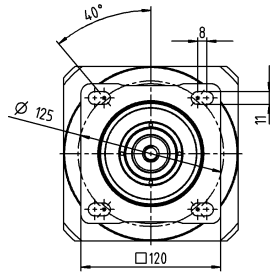

2-stage

up to 19⁴⁾ (E)⁵⁾
clamping hub
diameter

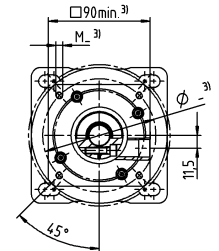
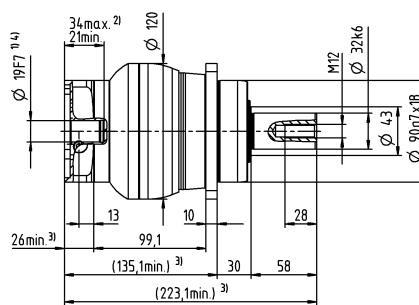
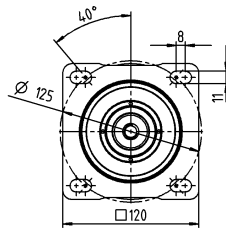

up to 28⁴⁾ (H)
clamping hub
diameter

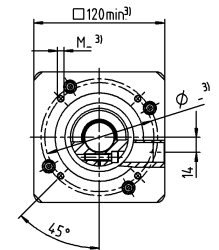
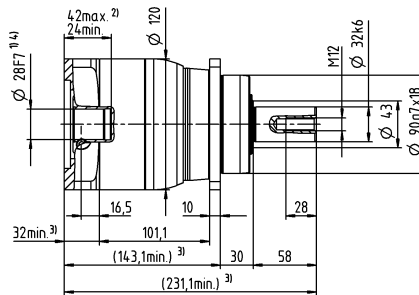
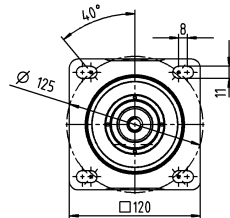

Motor shaft diameter [mm]

Other output variants

Shaft with key

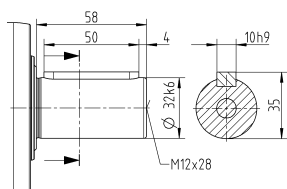

Splined shaft (DIN 5480)

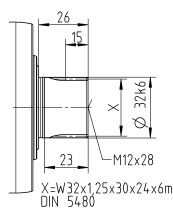

Non-tolerated dimensions are nominal dimensions

¹⁾ Check motor shaft fit

²⁾ Min. / Max. permissible motor shaft length

Longer motor shafts are possible, please contact alpha

³⁾ The dimensions depend on the motor

⁴⁾ Smaller motor shaft diameter is compensated

by a bushing with a minimum wall thickness of 1 mm

⁵⁾ Standard clamping hub diameter

NTP 015 MQ 1-stage

			1-stage					
Ratio	i		4	5	7	10		
Max. torque ^{a) b)}	T_{2a}	Nm	56	64	64	56		
		in.lb	496	566	566	496		
Max. acceleration torque (max. 1000 cycles per hour)	T_{2B}	Nm	35	40	40	35		
		in.lb	310	354	354	310		
Emergency stop torque ^{a) b)} (permitted 1000 times during the service life of the gearbox)	T_{2Not}	Nm	80	80	80	80		
		in.lb	708	708	708	708		
Permitted average input speed ^{d)} (at T_{2N} and 20 °C ambient temperature)	n_{1N}	rpm	3100	3300	3600	3800		
Max. input speed	n_{1Max}	rpm	8000	8000	8000	8000		
Mean no load running torque ^{b)} (at $n_1=3000$ rpm and 20 °C gearbox temperature)	T_{012}	Nm	0.78	0.66	0.52	0.42		
		in.lb	6.9	5.8	4.6	3.7		
Max. backlash	j_t	arcmin	≤ 7					
Torsional rigidity ^{b)}	C_{t21}	Nm/arcmin	7	7	7	5.5		
		in.lb/arcmin	62	62	62	49		
Max. axial force ^{c)}	F_{2AMax}	N	1900					
		lb _f	428					
Max. tilting moment	M_{2KMmax}	Nm	91					
		in.lb	805					
Efficiency at full load	η	%	97					
Service life	L_n	h	> 20000					
Weight (incl. standard adapter plate)	m	kg	1.6					
		lb _m	3.5					
Operating noise (at reference ratio and reference speed – ratio-specific values available in cymex®)	L_{PA}	dB(A)	≤ 58					
Max. permitted housing temperature		°C	+90					
		°F	+194					
Ambient temperature		°C	-15 to +40					
		°F	+5 to +104					
Lubrication			Lubricated for life					
Direction of rotation			In- and output same direction					
Protection class			IP 65					
Elastomer coupling (recommended product type – validate sizing with cymex®)			ELT-00060BAX-031.50					
Bore diameter of coupling on the application side		mm	X = 018.000 - 032.000					
Mass moment of inertia (relates to the drive) Clamping hub diameter [mm]	A	9	J_1	kgcm ²	0.22	0.19	0.15	0.14
				10 ⁻³ in.lb.s ²	0.19	0.17	0.13	0.12
	B	11	J_1	kgcm ²	0.24	0.20	0.17	0.16
				10 ⁻³ in.lb.s ²	0.21	0.18	0.15	0.14
	C	14	J_1	kgcm ²	0.31	0.28	0.25	0.23
				10 ⁻³ in.lb.s ²	0.27	0.25	0.22	0.20

Please use our sizing software cymex® for a detailed sizing – www.wittenstein-cymex.com

^{a)} Valid for torque transmission only

^{b)} Valid for standard clamping hub diameter

^{c)} Refers to center of the output shaft or flange

^{d)} Please reduce input speed at higher ambient temperatures

Motor shaft diameter [mm]

1-stage

up to 14⁴⁾ (C)⁵⁾
clamping hub diameter

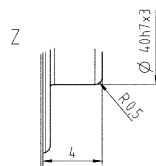
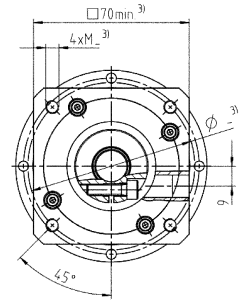
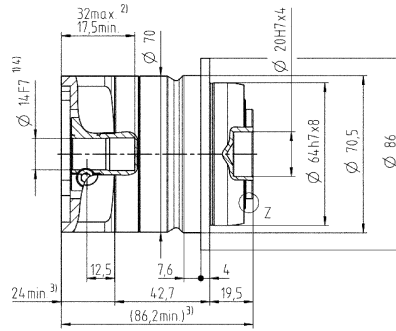
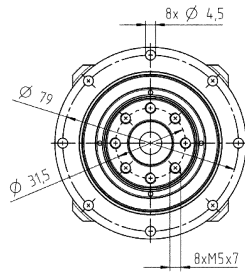

Non-tolerated dimensions are nominal dimensions

¹⁾ Check motor shaft fit

²⁾ Min. / Max. permissible motor shaft length

Longer motor shafts are possible, please contact alpha

³⁾ The dimensions depend on the motor

⁴⁾ Smaller motor shaft diameter is compensated

by a bushing with a minimum wall thickness of 1 mm

⁵⁾ Standard clamping hub diameter

NTP 015J MQ 2-stage

			2-stage										
Ratio	i		16	20	25	28	35	40	50	70	100		
Max. torque ^{a) b)}	T_{2a}	Nm	56	56	64	56	64	56	64	64	56		
		in.lb	496	496	566	496	566	496	566	566	496		
Max. acceleration torque (max. 1000 cycles per hour)	T_{2B}	Nm	35	35	40	35	40	35	40	40	35		
		in.lb	310	310	354	310	354	310	354	354	310		
Emergency stop torque ^{a) b)} (permitted 1000 times during the service life of the gearbox)	T_{2Not}	Nm	80	80	80	80	80	80	80	80	80		
		in.lb	708	708	708	708	708	708	708	708	708		
Permitted average input speed ^{d)} (at T_{2N} and 20 °C ambient temperature)	n_{1N}	rpm	3100	3300	3300	3600	3300	3800	3800	3800	3800		
Max. input speed	n_{1Max}	rpm	8000	8000	8000	8000	8000	8000	8000	8000	8000		
Mean no load running torque ^{b)} (at $n_1=3000$ rpm and 20 °C gearbox temperature)	T_{012}	Nm	0.35	0.31	0.29	0.27	0.26	0.25	0.23	0.22	0.21		
		in.lb	3.1	2.7	2.6	2.4	2.3	2.2	2.0	1.9	1.9		
Max. backlash	j_t	arcmin	≤ 8										
Torsional rigidity ^{b)}	C_{t21}	Nm/arcmin	7	7	7	7	7	7	7	7	5.5		
		in.lb/arcmin	62	62	62	62	62	62	62	62	49		
Max. axial force ^{c)}	F_{2AMax}	N	1900										
		lb _f	428										
Max. tilting moment	M_{2KMMax}	Nm	91										
		in.lb	805										
Efficiency at full load	η	%	95										
Service life	L_n	h	> 20000										
Weight (incl. standard adapter plate)	m	kg	2.1										
		lb _m	4.6										
Operating noise (at reference ratio and reference speed – ratio-specific values available in cymex®)	L_{PA}	dB(A)	≤ 58										
Max. permitted housing temperature		°C	+90										
		°F	+194										
Ambient temperature		°C	-15 to +40										
		°F	+5 to +104										
Lubrication			Lubricated for life										
Direction of rotation			In- and output same direction										
Protection class			IP 65										
Elastomer coupling (recommended product type – validate sizing with cymex®)			ELT-00060BAX-031.50										
Bore diameter of coupling on the application side		mm	X = 018.000 - 032.000										
Mass moment of inertia (relates to the drive) Clamping hub diameter [mm]	A	9	J_1	kgcm ²	0.17	0.17	0.15	0.16	0.15	0.16	0.14	0.13	0.13
				10 ⁻³ in.lb.s ²	0.15	0.15	0.13	0.14	0.13	0.14	0.12	0.12	0.12
	B	11	J_1	kgcm ²	0.19	0.18	0.17	0.18	0.16	0.17	0.16	0.15	0.15
				10 ⁻³ in.lb.s ²	0.17	0.16	0.15	0.16	0.14	0.15	0.14	0.13	0.13
	C	14	J_1	kgcm ²	0.26	0.26	0.25	0.25	0.24	0.25	0.24	0.23	0.22
				10 ⁻³ in.lb.s ²	0.23	0.23	0.22	0.22	0.21	0.22	0.21	0.20	0.19

Please use our sizing software cymex® for a detailed sizing – www.wittenstein-cymex.com

^{a)} Valid for torque transmission only

^{b)} Valid for standard clamping hub diameter

^{c)} Refers to center of the output shaft or flange

^{d)} Please reduce input speed at higher ambient temperatures

Motor shaft diameter [mm]

2-stage

up to 14⁴⁾ (C)
clamping hub diameter

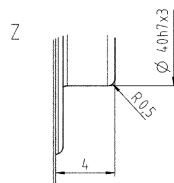
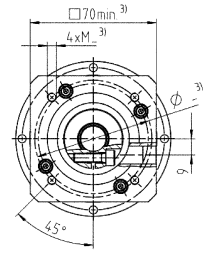
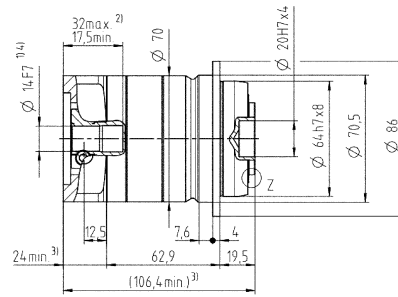
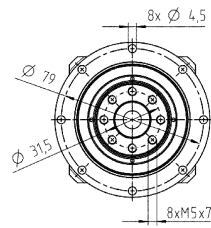

Non-tolerated dimensions are nominal dimensions

¹⁾ Check motor shaft fit

²⁾ Min. / Max. permissible motor shaft length

Longer motor shafts are possible, please contact alpha

³⁾ The dimensions depend on the motor

⁴⁾ Smaller motor shaft diameter is compensated by a bushing with a minimum wall thickness of 1 mm

⁵⁾ Standard clamping hub diameter

NTP 025 MQ 1-stage

			1-stage					
Ratio	i		4	5	7	10		
Max. torque ^{a) b)}	T_{2a}	Nm	152	160	160	144		
		in.lb	1345	1416	1416	1275		
Max. acceleration torque (max. 1000 cycles per hour)	T_{2B}	Nm	95	100	100	90		
		in.lb	841	885	885	797		
Emergency stop torque ^{a) b)} (permitted 1000 times during the service life of the gearbox)	T_{2Not}	Nm	190	190	190	190		
		in.lb	1682	1682	1682	1682		
Permitted average input speed ^{d)} (at T_{2N} and 20 °C ambient temperature)	n_{1N}	rpm	2900	3000	3200	3500		
Max. input speed	n_{1Max}	rpm	7000	7000	7000	7000		
Mean no load running torque ^{b)} (at $n_1=3000$ rpm and 20 °C gearbox temperature)	T_{012}	Nm	1.6	1.4	1.1	0.96		
		in.lb	14	12	9.7	8.5		
Max. backlash	j_t	arcmin	≤ 6					
Torsional rigidity ^{b)}	C_{t21}	Nm/arcmin	18	18	18	14		
		in.lb/arcmin	159	159	159	124		
Max. axial force ^{c)}	F_{2AMax}	N	2500					
		lb _f	563					
Max. tilting moment	M_{2KMMax}	Nm	220					
		in.lb	1947					
Efficiency at full load	η	%	97					
Service life	L_n	h	> 20000					
Weight (incl. standard adapter plate)	m	kg	3.7					
		lb _m	8.2					
Operating noise (at reference ratio and reference speed – ratio-specific values available in cymex®)	L_{PA}	dB(A)	≤ 61					
Max. permitted housing temperature		°C	+90					
		°F	+194					
Ambient temperature		°C	-15 to +40					
		°F	+5 to +104					
Lubrication			Lubricated for life					
Direction of rotation			In- and output same direction					
Protection class			IP 65					
Elastomer coupling (recommended product type – validate sizing with cymex®)			ELT-00150BAX-050.00					
Bore diameter of coupling on the application side		mm	X = 024.000 - 036.000					
Mass moment of inertia (relates to the drive) Clamping hub diameter [mm]	C	14	J_1	kgcm ²	0.68	0.51	0.4	0.29
				10 ⁻³ in.lb.s ²	0.6	0.45	0.35	0.26
	D	16	J_1	kgcm ²	0.82	0.66	0.5	0.4
				10 ⁻³ in.lb.s ²	0.73	0.58	0.44	0.35
	E	19	J_1	kgcm ²	0.91	0.74	0.6	0.52
				10 ⁻³ in.lb.s ²	0.81	0.65	0.53	0.46
	G	24	J_1	kgcm ²	1.9	1.8	1.6	1.6
				10 ⁻³ in.lb.s ²	1.7	1.6	1.4	1.4
	H	28	J_1	kgcm ²	1.7	1.5	1.3	1.3
				10 ⁻³ in.lb.s ²	1.5	1.3	1.2	1.2

Please use our sizing software cymex® for a detailed sizing – www.wittenstein-cymex.com

^{a)} Valid for torque transmission only

^{b)} Valid for standard clamping hub diameter

^{c)} Refers to center of the output shaft or flange

^{d)} Please reduce input speed at higher ambient temperatures

1-stage

up to 19⁴⁾ (E)⁵⁾
clamping hub
diameter

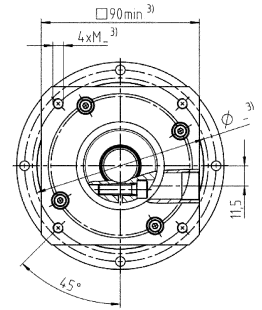
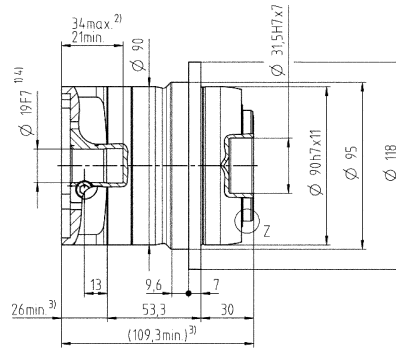
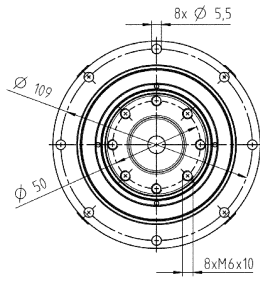

Motor shaft diameter [mm]

up to 28⁴⁾ (H)
clamping hub
diameter

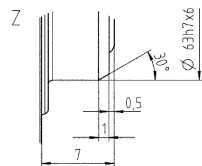
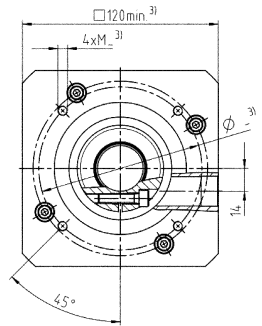
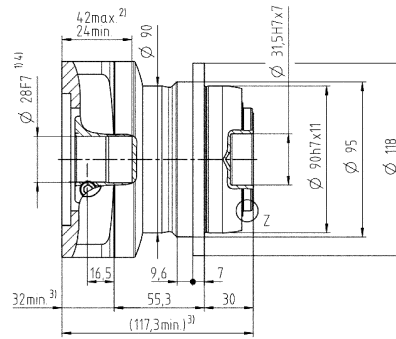
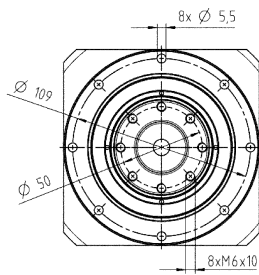

Non-tolerated dimensions are nominal dimensions

¹⁾ Check motor shaft fit

²⁾ Min. / Max. permissible motor shaft length

Longer motor shafts are possible, please contact alpha

³⁾ The dimensions depend on the motor

⁴⁾ Smaller motor shaft diameter is compensated

by a bushing with a minimum wall thickness of 1 mm

⁵⁾ Standard clamping hub diameter

NTP 025 MQ 2-stage

			2-stage										
Ratio	i		16	20	25	28	35	40	50	70	100		
Max. torque ^{a) b)}	T_{2a}	Nm	152	152	160	152	160	152	160	160	144		
		in.lb	1345	1345	1416	1345	1416	1345	1416	1416	1275		
Max. acceleration torque (max. 1000 cycles per hour)	T_{2B}	Nm	95	95	100	95	100	95	100	100	90		
		in.lb	841	841	885	841	885	841	885	885	797		
Emergency stop torque ^{a) b)} (permitted 1000 times during the service life of the gearbox)	T_{2Not}	Nm	190	190	190	190	190	190	190	190	190		
		in.lb	1682	1682	1682	1682	1682	1682	1682	1682	1682		
Permitted average input speed ^{d)} (at T_{2N} and 20 °C ambient temperature)	n_{1N}	rpm	3500	3700	3700	4000	4000	4300	4300	4300	4300		
Max. input speed	n_{1Max}	rpm	8000	8000	8000	8000	8000	8000	8000	8000	8000		
Mean no load running torque ^{b)} (at $n_1=3000$ rpm and 20 °C gearbox temperature)	T_{012}	Nm	0.46	0.4	0.36	0.34	0.31	0.29	0.27	0.25	0.23		
		in.lb	4.1	3.5	3.2	3.0	2.7	2.6	2.4	2.2	2.0		
Max. backlash	j_t	arcmin	≤ 7										
Torsional rigidity ^{b)}	C_{t21}	Nm/arcmin	18	18	18	18	18	18	18	18	14		
		in.lb/arcmin	159	159	159	159	159	159	159	159	124		
Max. axial force ^{c)}	F_{2AMax}	N	2500										
		lb _f	563										
Max. tilting moment	M_{2KMMax}	Nm	220										
		in.lb	1947										
Efficiency at full load	η	%	95										
Service life	L_n	h	> 20000										
Weight (incl. standard adapter plate)	m	kg	4										
		lb _m	8.8										
Operating noise (at reference ratio and reference speed – ratio-specific values available in cymex®)	L_{PA}	dB(A)	≤ 58										
Max. permitted housing temperature		°C	+90										
		°F	+194										
Ambient temperature		°C	-15 to +40										
		°F	+5 to +104										
Lubrication			Lubricated for life										
Direction of rotation			In- and output same direction										
Protection class			IP 65										
Elastomer coupling (recommended product type – validate sizing with cymex®)			ELT-00150BAX-050.00										
Bore diameter of coupling on the application side		mm	X = 024.000 - 036.000										
Mass moment of inertia (relates to the drive) Clamping hub diameter [mm]	A	9	J_1	kgcm ²	0.22	0.2	0.2	0.2	0.19	0.19	0.19	0.19	0.19
				10 ⁻³ in.lb.s ²	0.19	0.18	0.18	0.18	0.17	0.17	0.17	0.17	0.17
	B	11	J_1	kgcm ²	0.24	0.23	0.22	0.22	0.21	0.21	0.21	0.21	0.21
				10 ⁻³ in.lb.s ²	0.21	0.2	0.19	0.19	0.19	0.19	0.19	0.19	0.19
	C	14	J_1	kgcm ²	0.3	0.3	0.3	0.29	0.29	0.29	0.28	0.28	0.28
				10 ⁻³ in.lb.s ²	0.27	0.27	0.27	0.26	0.26	0.26	0.25	0.25	0.25
	D	16	J_1	kgcm ²	0.45	0.43	0.43	0.42	0.41	0.41	0.41	0.41	0.41
				10 ⁻³ in.lb.s ²	0.4	0.38	0.38	0.37	0.36	0.36	0.36	0.36	0.36
	E	19	J_1	kgcm ²	0.53	0.51	0.5	0.5	0.5	0.5	0.49	0.49	0.49
				10 ⁻³ in.lb.s ²	0.47	0.45	0.44	0.44	0.44	0.44	0.43	0.43	0.43

Please use our sizing software cymex® for a detailed sizing – www.wittenstein-cymex.com

^{a)} Valid for torque transmission only

^{b)} Valid for standard clamping hub diameter

^{c)} Refers to center of the output shaft or flange

^{d)} Please reduce input speed at higher ambient temperatures

2-stage

Motor shaft diameter [mm]

up to 14⁴⁾ (C)⁵⁾
clamping hub diameter

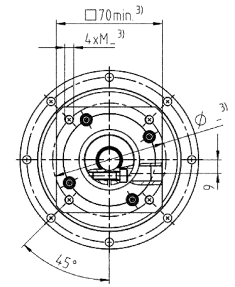
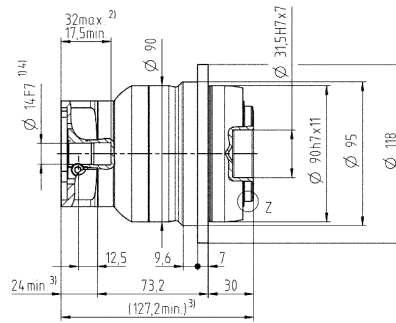
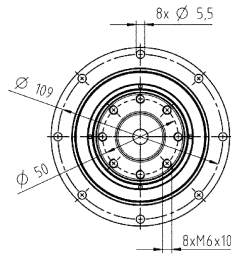

up to 19⁴⁾ (E)
clamping hub diameter

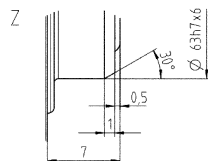
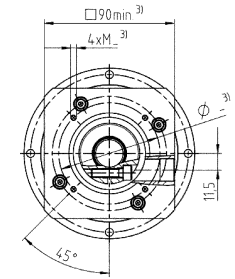
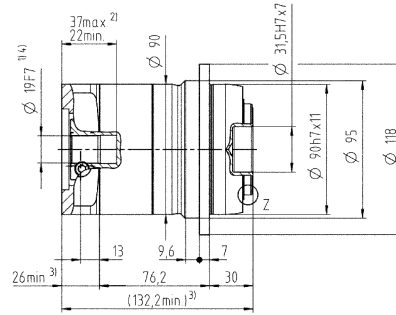
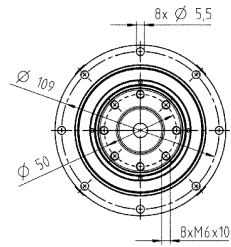

Non-tolerated dimensions are nominal dimensions

¹⁾ Check motor shaft fit

²⁾ Min. / Max. permissible motor shaft length

Longer motor shafts are possible, please contact alpha

³⁾ The dimensions depend on the motor

⁴⁾ Smaller motor shaft diameter is compensated by a bushing with a minimum wall thickness of 1 mm

⁵⁾ Standard clamping hub diameter

NTP 035 MQ 1-stage

			1-stage					
Ratio	i		4	5	7	10		
Max. torque ^{a) b)}	T_{2a}	Nm	408	400	400	352		
		in.lb	3611	3540	3540	3115		
Max. acceleration torque (max. 1000 cycles per hour)	T_{2B}	Nm	255	250	250	220		
		in.lb	2257	2213	2213	1947		
Emergency stop torque ^{a) b)} (permitted 1000 times during the service life of the gearbox)	T_{2Not}	Nm	500	500	500	500		
		in.lb	4425	4425	4425	4425		
Permitted average input speed ^{d)} (at T_{2N} and 20 °C ambient temperature)	n_{1N}	rpm	2200	2300	2500	2700		
Max. input speed	n_{1Max}	rpm	6000	6000	6000	6000		
Mean no load running torque ^{b)} (at $n_1=3000$ rpm and 20 °C gearbox temperature)	T_{012}	Nm	2.8	2.4	1.9	1.6		
		in.lb	25	21	17	14		
Max. backlash	j_t	arcmin	≤ 5					
Torsional rigidity ^{b)}	C_{t21}	Nm/arcmin	40	40	40	30		
		in.lb/arcmin	354	354	354	266		
Max. axial force ^{c)}	F_{2AMax}	N	4300					
		lb _f	968					
Max. tilting moment	M_{2KMMax}	Nm	360					
		in.lb	3186					
Efficiency at full load	η	%	97					
Service life	L_n	h	> 20000					
Weight (incl. standard adapter plate)	m	kg	7.8					
		lb _m	17					
Operating noise (at reference ratio and reference speed – ratio-specific values available in cymex [®])	L_{PA}	dB(A)	≤ 64					
Max. permitted housing temperature		°C	+90					
		°F	+194					
Ambient temperature		°C	-15 to +40					
		°F	+5 to +104					
Lubrication			Lubricated for life					
Direction of rotation			In- and output same direction					
Protection class			IP 65					
Elastomer coupling (recommended product type – validate sizing with cymex [®])			ELT-00300BAX-063.00					
Bore diameter of coupling on the application side		mm	X = 035.000 - 045.000					
Mass moment of inertia (relates to the drive) Clamping hub diameter [mm]	E	19	J_1	kgcm ²	2.3	1.7	1.0	0.97
				10 ⁻³ in.lb.s ²	2.0	1.5	0.89	0.86
	G	24	J_1	kgcm ²	3.1	2.5	2.0	1.7
				10 ⁻³ in.lb.s ²	2.7	2.2	1.8	1.5
	H	28	J_1	kgcm ²	2.8	2.2	1.7	1.5
				10 ⁻³ in.lb.s ²	2.5	1.9	1.5	1.3
	I	32	J_1	kgcm ²	6.9	6.3	5.8	5.5
				10 ⁻³ in.lb.s ²	6.1	5.6	5.1	4.9
	K	38	J_1	kgcm ²	8.0	7.5	6.9	6.7
				10 ⁻³ in.lb.s ²	7.1	6.6	6.1	5.9

Please use our sizing software cymex[®] for a detailed sizing – www.wittenstein-cymex.com

^{a)} Valid for torque transmission only

^{b)} Valid for standard clamping hub diameter

^{c)} Refers to center of the output shaft or flange

^{d)} Please reduce input speed at higher ambient temperatures

1-stage

up to 24/28⁴⁾
(G⁵⁾/H)
clamping hub diameter

Motor shaft diameter [mm]

up to 38⁴⁾ (K)
clamping hub diameter

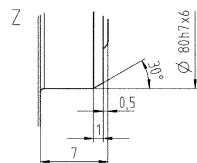
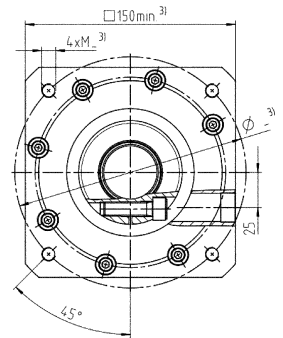
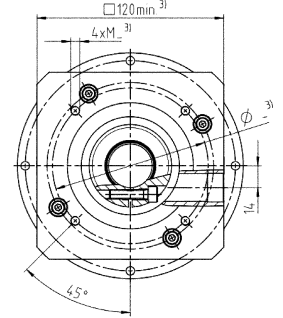
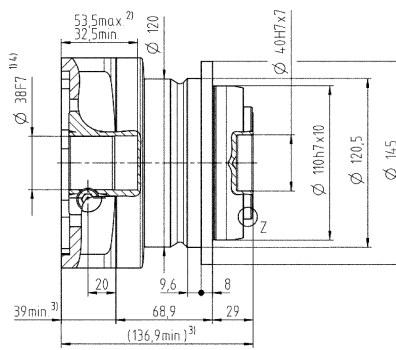
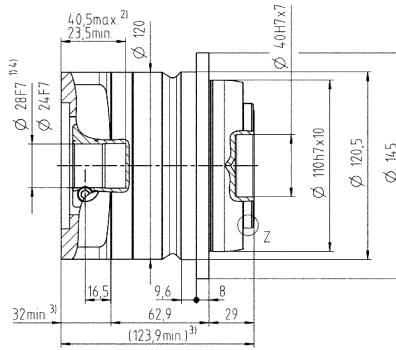
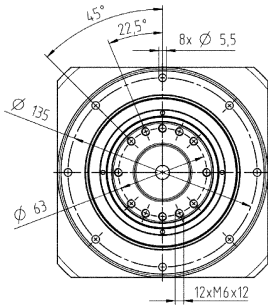
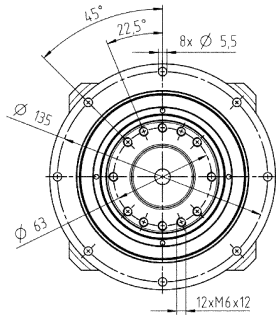

Non-tolerated dimensions are nominal dimensions

¹⁾ Check motor shaft fit

²⁾ Min. / Max. permissible motor shaft length

Longer motor shafts are possible, please contact alpha

³⁾ The dimensions depend on the motor

⁴⁾ Smaller motor shaft diameter is compensated by a bushing with a minimum wall thickness of 1 mm

⁵⁾ Standard clamping hub diameter

NTP 035 MQ 2-stage

			2-stage										
Ratio	i		16	20	25	28	35	40	50	70	100		
Max. torque ^{a) b)}	T_{2a}	Nm	408	408	400	408	400	408	400	400	352		
		in.lb	3611	3611	3540	3611	3540	3611	3540	3540	3115		
Max. acceleration torque (max. 1000 cycles per hour)	T_{2B}	Nm	255	255	250	255	250	255	250	250	220		
		in.lb	2257	2257	2213	2257	2213	2257	2213	2213	1947		
Emergency stop torque ^{a) b)} (permitted 1000 times during the service life of the gearbox)	T_{2Not}	Nm	500	500	500	500	500	500	500	500	500		
		in.lb	4425	4425	4425	4425	4425	4425	4425	4425	4425		
Permitted average input speed ^{d)} (at T_{2N} and 20 °C ambient temperature)	n_{1N}	rpm	3300	3400	3400	3600	3600	3900	3900	3900	3900		
Max. input speed	n_{1Max}	rpm	7000	7000	7000	7000	7000	7000	7000	7000	7000		
Mean no load running torque ^{b)} (at $n_1=3000$ rpm and 20 °C gearbox temperature)	T_{012}	Nm	1.2	1.1	1	0.93	0.87	0.81	0.77	0.72	0.68		
		in.lb	11	9.7	8.9	8.2	7.7	7.2	6.8	6.4	6.0		
Max. backlash	j_t	arcmin	≤ 6										
Torsional rigidity ^{b)}	C_{t21}	Nm/arcmin	40	40	40	40	40	40	40	40	30		
		in.lb/arcmin	354	354	354	354	354	354	354	354	266		
Max. axial force ^{c)}	F_{2AMax}	N	4300										
		lb _f	968										
Max. tilting moment	M_{2KMmax}	Nm	360										
		in.lb	3186										
Efficiency at full load	η	%	95										
Service life	L_n	h	> 20000										
Weight (incl. standard adapter plate)	m	kg	8.2										
		lb _m	18										
Operating noise (at reference ratio and reference speed – ratio-specific values available in cymex®)	L_{PA}	dB(A)	≤ 60										
Max. permitted housing temperature		°C	+90										
		°F	+194										
Ambient temperature		°C	-15 to +40										
		°F	+5 to +104										
Lubrication			Lubricated for life										
Direction of rotation			In- and output same direction										
Protection class			IP 65										
Elastomer coupling (recommended product type – validate sizing with cymex®)			ELT-00300BAX-063.00										
Bore diameter of coupling on the application side		mm	X = 035.000 - 045.000										
Mass moment of inertia (relates to the drive) Clamping hub diameter [mm]	C	14	J_1	kgcm ²	0.47	0.45	0.37	0.38	0.32	0.37	0.31	0.27	0.24
				10 ⁻³ in.lb.s ²	0.42	0.4	0.33	0.34	0.28	0.33	0.27	0.24	0.21
	D	16	J_1	kgcm ²	0.62	0.59	0.5	0.5	0.46	0.52	0.46	0.42	0.39
				10 ⁻³ in.lb.s ²	0.55	0.52	0.44	0.44	0.41	0.46	0.41	0.37	0.35
	E	19	J_1	kgcm ²	0.7	0.68	0.61	0.6	0.56	0.6	0.55	0.5	0.48
				10 ⁻³ in.lb.s ²	0.62	0.6	0.54	0.53	0.5	0.53	0.49	0.44	0.42
	G	24	J_1	kgcm ²	1.7	1.7	1.6	1.7	1.6	1.6	1.6	1.5	1.5
				10 ⁻³ in.lb.s ²	1.5	1.5	1.4	1.5	1.4	1.4	1.4	1.3	1.3
	H	28	J_1	kgcm ²	1.4	1.4	1.3	1.4	1.3	1.3	1.3	1.2	1.2
				10 ⁻³ in.lb.s ²	1.2	1.2	1.2	1.2	1.2	1.2	1.2	1.1	1.1

Please use our sizing software cymex® for a detailed sizing – www.wittenstein-cymex.com

^{a)} Valid for torque transmission only

^{b)} Valid for standard clamping hub diameter

^{c)} Refers to center of the output shaft or flange

^{d)} Please reduce input speed at higher ambient temperatures

2-stage

Motor shaft diameter [mm]

up to 19⁴⁾ (E)⁵⁾
clamping hub diameter

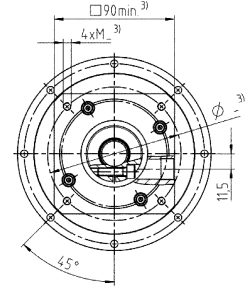
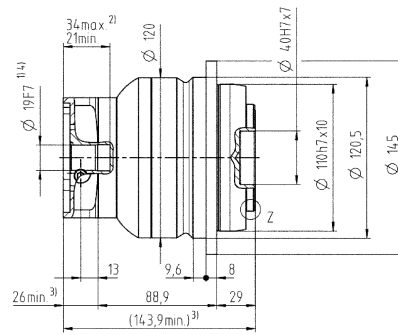
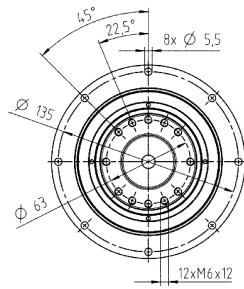

up to 28⁴⁾ (H)
clamping hub diameter

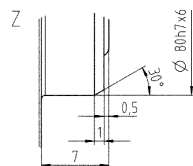
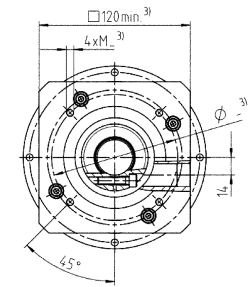
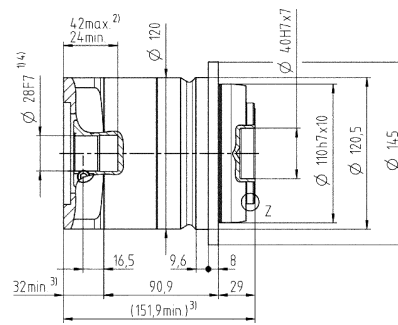
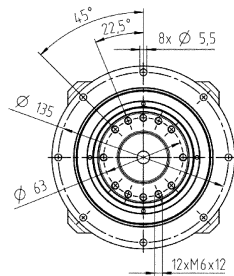

Non-tolerated dimensions are nominal dimensions

¹⁾ Check motor shaft fit

²⁾ Min. / Max. permissible motor shaft length

Longer motor shafts are possible, please contact alpha

³⁾ The dimensions depend on the motor

⁴⁾ Smaller motor shaft diameter is compensated by a bushing with a minimum wall thickness of 1 mm

⁵⁾ Standard clamping hub diameter

NTP 045 MQ 1-stage

			1-stage					
Ratio	i		4	5	7	10		
Max. torque ^{a) b)}	T_{2a}	Nm	800	800	800	640		
		in.lb	7081	7081	7081	5665		
Max. acceleration torque (max. 1000 cycles per hour)	T_{2B}	Nm	500	500	500	400		
		in.lb	4425	4425	4425	3540		
Emergency stop torque ^{a) b)} (permitted 1000 times during the service life of the gearbox)	T_{2Not}	Nm	1000	1000	1000	1000		
		in.lb	8851	8851	8851	8851		
Permitted average input speed ^{d)} (at T_{2N} and 20 °C ambient temperature)	n_{1N}	rpm	1800	1800	1800	2000		
Max. input speed	n_{1Max}	rpm	4000	4000	4000	4000		
Mean no load running torque ^{b)} (at $n_1=3000$ rpm and 20 °C gearbox temperature)	T_{012}	Nm	5.5	4.6	3.5	2.6		
		in.lb	49	41	31	23		
Max. backlash	j_t	arcmin	≤ 5					
Torsional rigidity ^{b)}	C_{t21}	Nm/arcmin	110	110	110	80		
		in.lb/arcmin	974	974	974	708		
Max. axial force ^{c)}	F_{2AMax}	N	5500					
		lb _f	1238					
Max. tilting moment	M_{2KMMax}	Nm	1070					
		in.lb	9470					
Efficiency at full load	η	%	97					
Service life	L_n	h	> 20000					
Weight (incl. standard adapter plate)	m	kg	16					
		lb _m	35					
Operating noise (at reference ratio and reference speed – ratio-specific values available in cymex®)	L_{PA}	dB(A)	≤ 67					
Max. permitted housing temperature		°C	+90					
		°F	+194					
Ambient temperature		°C	-15 to +40					
		°F	+5 to +104					
Lubrication			Lubricated for life					
Direction of rotation			In- and output same direction					
Protection class			IP 65					
Elastomer coupling (recommended product type – validate sizing with cymex®)			ELT-00450BAX-080.00					
Bore diameter of coupling on the application side		mm	X = 042.000 - 060.000					
Mass moment of inertia (relates to the drive) Clamping hub diameter [mm]	K	38	J_1	kgcm ²	11.2	9.8	8.2	7.4
				10 ⁻³ in.lb.s ²	9.9	8.7	7.3	6.5

Please use our sizing software cymex® for a detailed sizing – www.wittenstein-cymex.com

^{a)} Valid for torque transmission only

^{b)} Valid for standard clamping hub diameter

^{c)} Refers to center of the output shaft or flange

^{d)} Please reduce input speed at higher ambient temperatures

Motor shaft diameter [mm]

1-stage

up to 38⁴⁾ (K)
clamping hub diameter

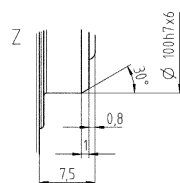
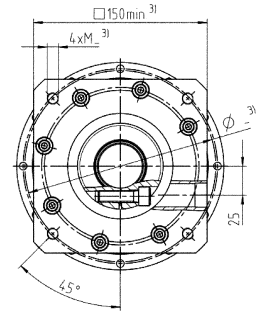
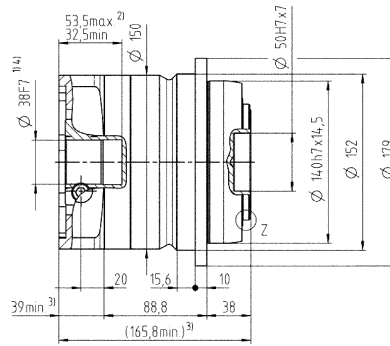
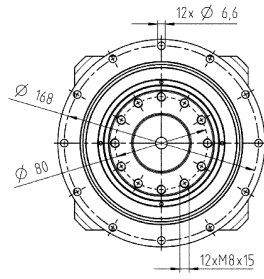

Non-tolerated dimensions are nominal dimensions

¹⁾ Check motor shaft fit

²⁾ Min. / Max. permissible motor shaft length

Longer motor shafts are possible, please contact alpha

³⁾ The dimensions depend on the motor

⁴⁾ Smaller motor shaft diameter is compensated by a bushing with a minimum wall thickness of 1 mm

⁵⁾ Standard clamping hub diameter

NTP 045 MQ 2-stage

			2-stage										
Ratio	i		16	20	25	28	35	40	50	70	100		
Max. torque ^{a) b)}	T_{2a}	Nm	700	700	700	700	700	700	700	700	640		
		in.lb	6196	6196	6196	6196	6196	6196	6196	6196	5665		
Max. acceleration torque (max. 1000 cycles per hour)	T_{2B}	Nm	500	500	500	500	500	500	500	500	400		
		in.lb	4425	4425	4425	4425	4425	4425	4425	4425	3540		
Emergency stop torque ^{a) b)} (permitted 1000 times during the service life of the gearbox)	T_{2Not}	Nm	1000	1000	1000	1000	1000	1000	1000	1000	1000		
		in.lb	8851	8851	8851	8851	8851	8851	8851	8851	8851		
Permitted average input speed ^{d)} (at T_{2N} and 20 °C ambient temperature)	n_{1N}	rpm	2500	2600	2600	2800	2800	3000	3000	3000	3000		
Max. input speed	n_{1Max}	rpm	6000	6000	6000	6000	6000	6000	6000	6000	6000		
Mean no load running torque ^{b)} (at $n_1=3000$ rpm and 20 °C gearbox temperature)	T_{012}	Nm	2.1	1.8	1.6	1.5	1.4	1.3	1.2	1.1	0.97		
		in.lb	19	16	14	13	12	12	11	9.7	8.6		
Max. backlash	j_t	arcmin	≤ 6										
Torsional rigidity ^{b)}	C_{t21}	Nm/arcmin	110	110	110	110	110	110	110	110	80		
		in.lb/arcmin	974	974	974	974	974	974	974	974	708		
Max. axial force ^{c)}	F_{2AMax}	N	5500										
		lb _f	1238										
Max. tilting moment	M_{2KMmax}	Nm	1070										
		in.lb	9470										
Efficiency at full load	η	%	95										
Service life	L_n	h	> 20000										
Weight (incl. standard adapter plate)	m	kg	17										
		lb _m	38										
Operating noise (at reference ratio and reference speed – ratio-specific values available in cymex®)	L_{PA}	dB(A)	≤ 64										
Max. permitted housing temperature		°C	+90										
		°F	+194										
Ambient temperature		°C	-15 to +40										
		°F	+5 to +104										
Lubrication			Lubricated for life										
Direction of rotation			In- and output same direction										
Protection class			IP 65										
Elastomer coupling (recommended product type – validate sizing with cymex®)			ELT-00450BAX-080.00										
Bore diameter of coupling on the application side		mm	X = 042.000 - 060.000										
Mass moment of inertia (relates to the drive) Clamping hub diameter [mm]	E	19	J_1	kgcm ²	1.6	1.5	1.4	1.3	1.1	1.2	1.0	0.87	0.83
				10 ⁻³ in.lb.s ²	1.4	1.3	1.2	1.2	0.97	1.1	0.89	0.77	0.73
	G	24	J_1	kgcm ²	2.4	2.3	2.0	2.0	1.9	2.0	2.1	1.6	1.6
				10 ⁻³ in.lb.s ²	2.1	2.0	1.8	1.8	1.7	1.8	1.9	1.4	1.4
	H	28	J_1	kgcm ²	2.1	2.0	1.9	1.8	1.6	1.7	1.8	1.4	1.3
				10 ⁻³ in.lb.s ²	1.9	1.8	1.7	1.6	1.4	1.5	1.6	1.2	1.2
	I	32	J_1	kgcm ²	6.2	6.0	6.0	5.9	5.7	5.8	5.9	5.4	5.4
				10 ⁻³ in.lb.s ²	5.5	5.3	5.3	5.2	5.0	5.1	5.2	4.8	4.8
	K	38	J_1	kgcm ²	7.4	7.2	7.0	7.0	6.8	6.9	7.0	6.6	6.5
				10 ⁻³ in.lb.s ²	6.5	6.4	6.2	6.2	6.0	6.1	6.2	5.8	5.8

Please use our sizing software cymex® for a detailed sizing – www.wittenstein-cymex.com

^{a)} Valid for torque transmission only

^{b)} Valid for standard clamping hub diameter

^{c)} Refers to center of the output shaft or flange

^{d)} Please reduce input speed at higher ambient temperatures

2-stage

Motor shaft diameter [mm]

up to 28⁴⁾ (H)⁵⁾
clamping hub diameter

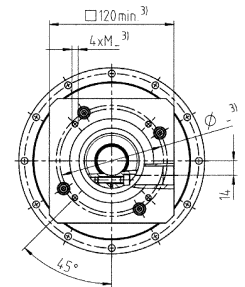
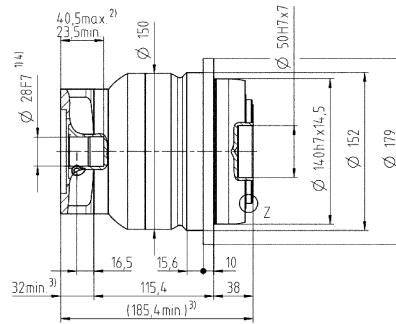
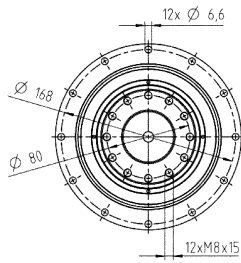

up to 38⁴⁾ (K)
clamping hub diameter

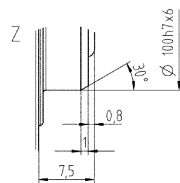
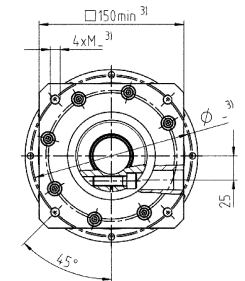
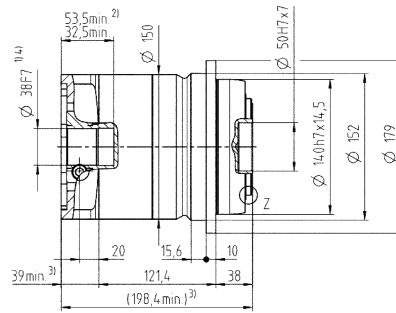
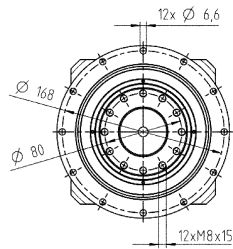

Non-tolerated dimensions are nominal dimensions

¹⁾ Check motor shaft fit

²⁾ Min. / Max. permissible motor shaft length

Longer motor shafts are possible, please contact alpha

³⁾ The dimensions depend on the motor

⁴⁾ Smaller motor shaft diameter is compensated by a bushing with a minimum wall thickness of 1 mm

⁵⁾ Standard clamping hub diameter

alpha Value Line

BEVEL GEARBOXES

NPK / NPLK / NPSK / NPTK / NPRK

The bevel gears of the alpha Value Line are the fitting solution for situations with limited mounting space. The flexible output shapes and gear ratios in combination with the extremely compact angle section offer comprehensive design freedom.

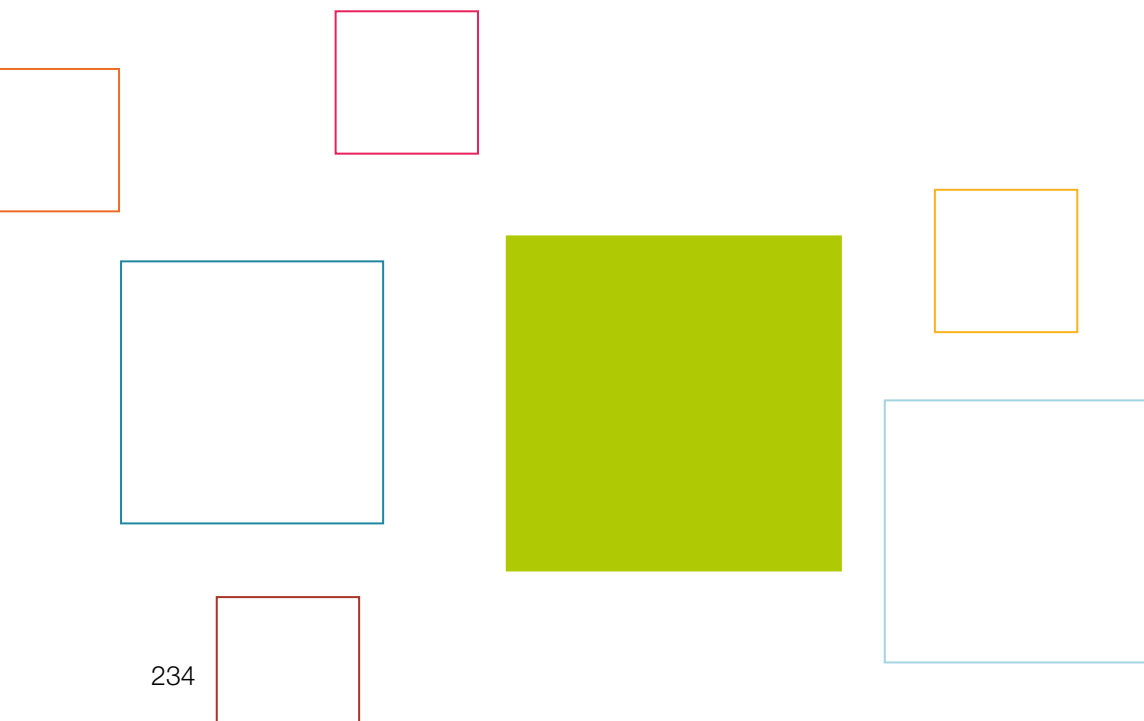



Bevel Gearboxes
Value Line

NPK / NPLK / NPSK / NPTK / NPRK

– Individual Talents

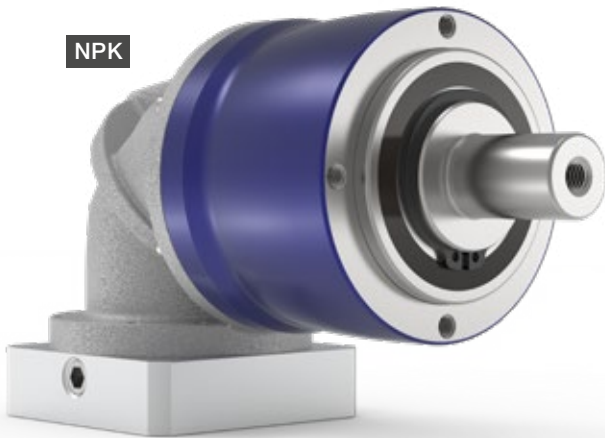

PRODUCT HIGHLIGHTS

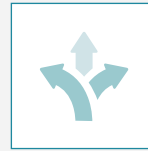

High flexibility

Various output versions offer design freedom tailored to individual requirements.



High economy

The gearboxes of the alpha Value Line are very economical to purchase, unbeatably efficient in operation, and maintenance free over their entire service life.



Fast sizing

Efficient and innovative online sizing within seconds in cymex® select based on technical and economic suitability.

Total flexibility, even in limited space. The bevel gearboxes of the alpha Value Line combine the variety of the NP series with a compact and powerful bevel gear stage. This permits maximum flexibility through the configuration of five different output versions.

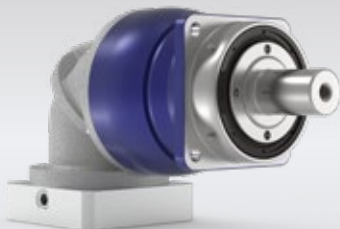

NPSK – bevel gearbox with SP+ output geometry

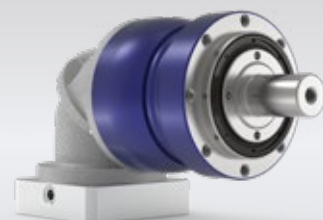

NPLK – bevel gearbox with reinforced bearings and B14 output geometry



More information about the alpha Value Line: simply scan the QR code using your smartphone.

alpha.wittenstein.de/en-en/alpha-value-line

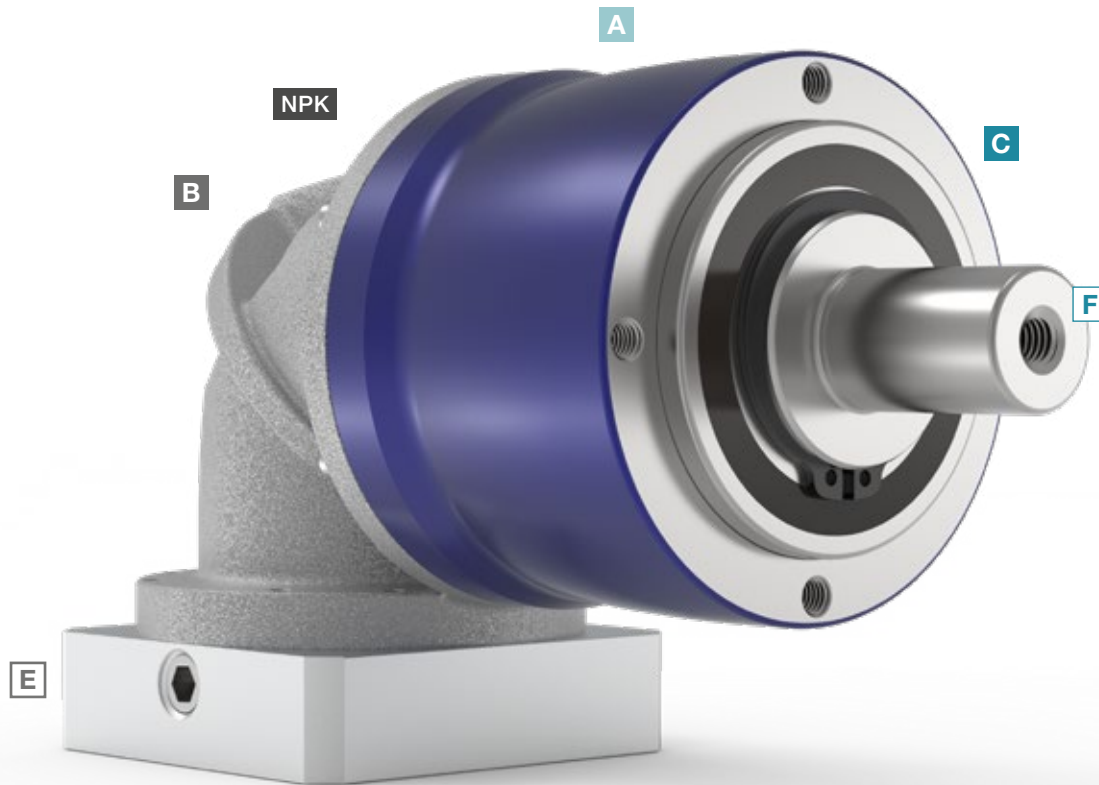

Bevel Gearboxes
Value Line

A

Design

- The elegant design underlines the dynamics of the gearbox and sets new standards on the market

B

Compactness

- The extremely compact design of the angle section enables use in very confined installation spaces

C

Various output shapes

- Five output variants of the NPK series available: including B5 flange mounting, output flange, etc.
- Higher external forces possible with NPLK, NPSK, and NPRK

D

High ratio variation

- Large number of ratios ($i=3$ to $i=100$)
- Available in the common binary ratios

E

Flexible motor connection

- Mounting of all common servo motors by means of a flexible and screw-fastened adapter plate
- Large number of motor shaft diameters connectable

F

Multiple output configurations for greater flexibility

- Smooth shaft
- Shaft with key
- Splined shaft (DIN 5480)
- Flange

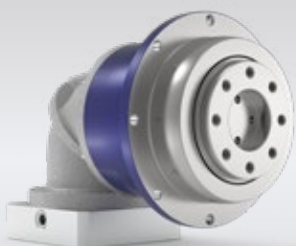

NPTK – bevel gearbox with TP+ output geometry



NPRK – bevel gearbox with slot holes for optimal rack and pinion mounting

NPK 005 MF 2-/3-stage

			2-stage					3-stage									
Ratio	i		4	5	7	8	10	16	20	25	28	35	40	50	64	70	100
Max. torque ^{a) b) e)}	T_{2a}	Nm	14	17	22	21	21	18	18	22	18	22	18	22	21	22	21
		in.lb	124	150	195	186	186	159	159	195	159	195	159	195	186	195	186
Max. acceleration torque ^{e)} (max. 1000 cycles per hour)	T_{2B}	Nm	6.8	8.5	12	13	13	11	11	13	11	13	11	13	13	13	13
		in.lb	60	75	106	115	115	97	97	115	97	115	97	115	115	115	115
Emergency stop torque ^{a) b) e)} (permitted 1000 times during the service life of the gearbox)	T_{2Not}	Nm	17	21	26	26	26	26	26	26	26	26	26	26	26	26	26
		in.lb	150	186	230	230	230	230	230	230	230	230	230	230	230	230	230
Permitted average input speed ^{d)} (at T_{2N} and 20 °C ambient temperature)	n_{1N}	rpm	3800	3800	3800	3800	3800	3800	3800	3800	3800	3800	3800	3800	3800	3800	3800
Max. input speed	n_{1Max}	rpm	5000	5000	5000	5000	5000	5000	5000	5000	5000	5000	5000	5000	5000	5000	5000
Mean no load running torque ^{b)} (at $n_1=3000$ rpm and 20 °C gearbox temperature)	T_{012}	Nm	0.28	0.28	0.28	0.28	0.28	0.29	0.29	0.29	0.29	0.29	0.29	0.29	0.29	0.29	0.29
		in.lb	2.5	2.5	2.5	2.5	2.5	2.6	2.6	2.6	2.6	2.6	2.6	2.6	2.6	2.6	2.6
Max. backlash	j_i	arcmin	≤ 15					≤ 15									
Torsional rigidity ^{b)}	C_{t21}	Nm/arcmin	0.9	0.9	0.9	0.9	0.9	1.2	1.2	1.2	1.2	1.2	1.2	1.2	1.2	1.2	1.2
		in.lb/arcmin	8	8	8	8	8	11	11	11	11	11	11	11	11	11	11
Max. axial force ^{c)}	F_{2AMax}	N	700					700									
		lb _f	158					158									
Max. lateral force ^{c)}	F_{2QMMax}	N	800					800									
		lb _f	180					180									
Max. tilting moment	M_{2KMMax}	Nm	23					23									
		in.lb	204					204									
Efficiency at full load	η	%	95					94									
Service life	L_n	h	> 20000					> 20000									
Weight (incl. standard adapter plate)	m	kg	1.1					1.3									
		lb _m	2.4					2.9									
Operating noise (at reference ratio and reference speed – ratio-specific values available in cymex®)	L_{PA}	dB(A)	≤ 68					≤ 68									
Max. permitted housing temperature		°C	+90					+90									
		°F	+194					+194									
Ambient temperature		°C	0 to +40					0 to +40									
		°F	+32 to +104					+32 to +104									
Lubrication			Lubricated for life														
Direction of rotation			In- and output same direction														
Protection class			IP 64														
Elastomer coupling (recommended product type – validate sizing with cymex®)			ELC-0005BA012.000-X														
Bore diameter of coupling on the application side		mm	X = 004.000 - 012.700														
Mass moment of inertia (relates to the drive) Clamping hub diameter [mm]	B	11	J_1	kgcm ²	0.1	0.1	0.1	0.1	0.1	0.11	0.11	0.11	0.11	0.11	0.11	0.11	0.11
				10 ⁻³ in.lb.s ²	0.09	0.09	0.09	0.09	0.09	0.1	0.1	0.1	0.1	0.1	0.1	0.1	0.1

Please use our sizing software cymex® for a detailed sizing – www.wittenstein-cymex.com
Please consider the maximal tilting moment caused by the motor M_{1KMot} – see sizing

- ^{a)} Valid for torque transmission only
- ^{b)} Valid for standard clamping hub diameter
- ^{c)} Refers to center of the output shaft or flange
- ^{d)} Please reduce input speed at higher ambient temperatures
- ^{e)} Valid for: Smooth shaft

2-stage

up to 11⁴⁾ (B)⁵⁾
clamping hub
diameter

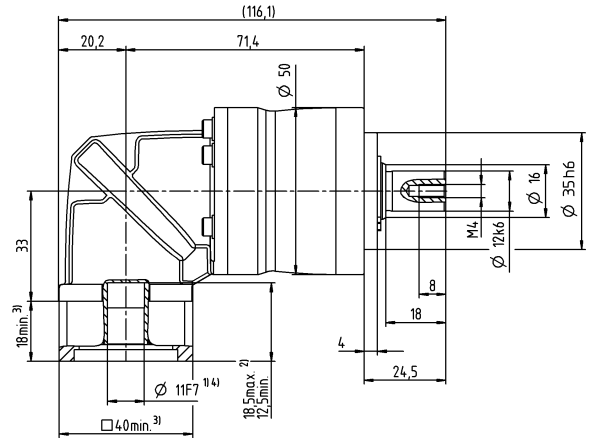
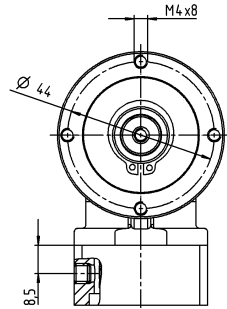

3-stage

up to 11⁴⁾ (B)⁵⁾
clamping hub
diameter

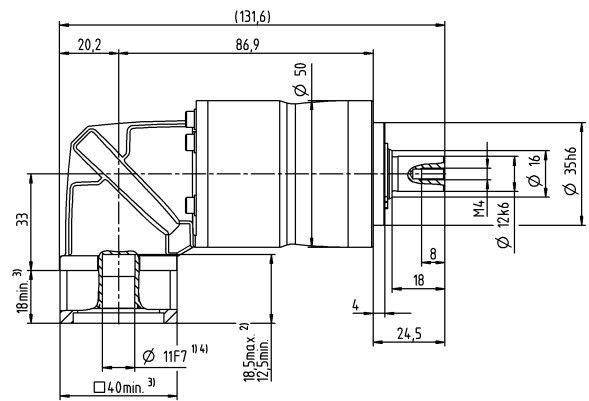
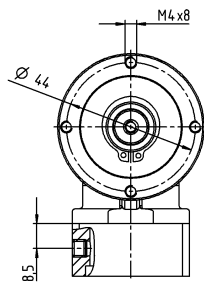

Motor shaft diameter [mm]

Other output variants

Shaft with key

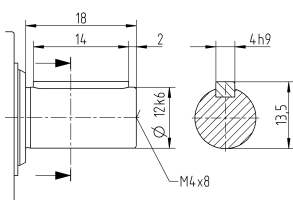

Non-tolerated dimensions are nominal dimensions

¹⁾ Check motor shaft fit

²⁾ Min. / Max. permissible motor shaft length

Longer motor shafts are possible, please contact alpha

³⁾ The dimensions depend on the motor

⁴⁾ Smaller motor shaft diameter is compensated

by a bushing with a minimum wall thickness of 1 mm

⁵⁾ Standard clamping hub diameter

NPK 015 MF 2-stage

			2-stage							
Ratio	i		3	4	5	7	8	10		
Max. torque ^{a) b) e)}	T_{2a}	Nm	33	44	55	64	56	56		
		in.lb	292	389	487	566	496	496		
Max. acceleration torque ^{b)} (max. 1000 cycles per hour)	T_{2B}	Nm	16	21	27	37	35	35		
		in.lb	142	186	239	327	310	310		
Emergency stop torque ^{a) b) e)} (permitted 1000 times during the service life of the gearbox)	T_{2Not}	Nm	41	55	69	80	80	80		
		in.lb	363	487	611	708	708	708		
Permitted average input speed ^{d)} (at T_{2a} and 20 °C ambient temperature)	n_{1N}	rpm	3300	3300	3300	3300	3300	3300		
Max. input speed	n_{1Max}	rpm	5000	5000	5000	5000	5000	5000		
Mean no load running torque ^{b)} (at $n_1=3000$ rpm and 20 °C gearbox temperature)	T_{012}	Nm	0.54	0.54	0.54	0.54	0.54	0.54		
		in.lb	4.8	4.8	4.8	4.8	4.8	4.8		
Max. backlash	j_t	arcmin	≤ 15							
Torsional rigidity ^{b)}	C_{t21}	Nm/arcmin	2.4	2.4	2.4	2.4	2.4	2.4		
		in.lb/arcmin	21	21	21	21	21	21		
Max. axial force ^{c)}	F_{2AMax}	N	1550							
		lb _f	349							
Max. lateral force ^{c)}	F_{2OMax}	N	1700							
		lb _f	383							
Max. tilting moment	M_{2KMMax}	Nm	72							
		in.lb	637							
Efficiency at full load	η	%	95							
Service life	L_h	h	> 20000							
Weight (incl. standard adapter plate)	m	kg	2.3							
		lb _m	5.1							
Operating noise (at reference ratio and reference speed – ratio-specific values available in cymex®)	L_{PA}	dB(A)	≤ 70							
Max. permitted housing temperature		°C	+90							
		°F	+194							
Ambient temperature		°C	0 to +40							
		°F	+32 to +104							
Lubrication			Lubricated for life							
Direction of rotation			In- and output same direction							
Protection class			IP 64							
Elastomer coupling (recommended product type – validate sizing with cymex®)			ELC-0060BA016.000-X							
Bore diameter of coupling on the application side		mm	X = 012.000 - 032.000							
Mass moment of inertia (relates to the drive) Clamping hub diameter [mm]	C	14	J_1	kgcm ²	0.31	0.31	0.31	0.31	0.31	0.31
				10 ⁻³ in.lb.s ²	0.27	0.27	0.27	0.27	0.27	0.27

Please use our sizing software cymex® for a detailed sizing – www.wittenstein-cymex.com
Please consider the maximal tilting moment caused by the motor M_{1KMot} – see sizing

^{a)} Valid for torque transmission only

^{b)} Valid for standard clamping hub diameter

^{c)} Refers to center of the output shaft or flange

^{d)} Please reduce input speed at higher ambient temperatures

^{e)} Valid for: Smooth shaft

Motor shaft diameter [mm]

2-stage

up to 14⁴⁾ (C)⁵⁾
clamping hub diameter

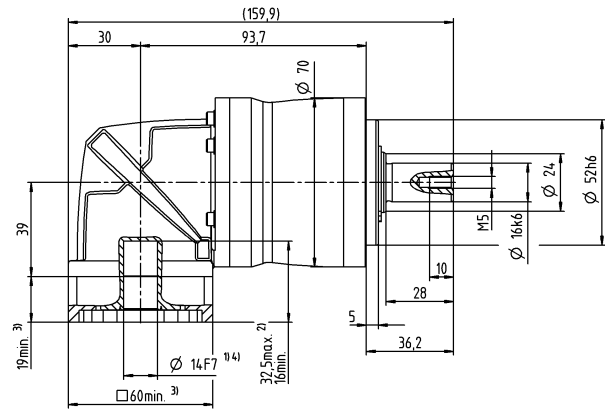
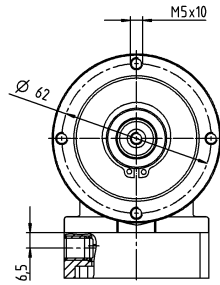

Other output variants

Shaft with key

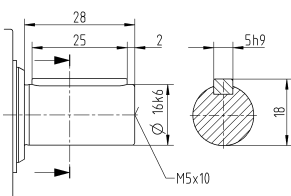

Non-tolerated dimensions are nominal dimensions

¹⁾ Check motor shaft fit

²⁾ Min. / Max. permissible motor shaft length

Longer motor shafts are possible, please contact alpha

³⁾ The dimensions depend on the motor

⁴⁾ Smaller motor shaft diameter is compensated

by a bushing with a minimum wall thickness of 1 mm

⁵⁾ Standard clamping hub diameter

NPK 015 MF 3-stage

			3-stage														
Ratio	i		12	15	16	20	25	28	30	32	35	40	50	64	70	100	
Max. torque ^{a) b) e)}	T_{2a}	Nm	42	51	56	56	64	56	51	56	64	56	64	56	64	56	
		in.lb	372	451	496	496	566	496	451	496	566	496	566	496	566	496	496
Max. acceleration torque ^{b)} (max. 1000 cycles per hour)	T_{2B}	Nm	20	25	27	34	40	35	31	35	40	35	40	35	40	35	
		in.lb	177	221	239	301	354	310	274	310	354	310	354	310	354	310	310
Emergency stop torque ^{a) b) e)} (permitted 1000 times during the service life of the gearbox)	T_{2Not}	Nm	52	65	70	80	80	80	80	80	80	80	80	80	80	80	
		in.lb	460	575	620	708	708	708	708	708	708	708	708	708	708	708	708
Permitted average input speed ^{d)} (at T_{2a} and 20 °C ambient temperature)	n_{1N}	rpm	3800	3800	3800	3800	3800	3800	3800	3800	3800	3800	3800	3800	3800	3800	
Max. input speed	n_{1Max}	rpm	5000	5000	5000	5000	5000	5000	5000	5000	5000	5000	5000	5000	5000	5000	
Mean no load running torque ^{b)} (at $n_1=3000$ rpm and 20 °C gearbox temperature)	T_{012}	Nm	0.31	0.31	0.31	0.31	0.31	0.31	0.31	0.31	0.31	0.31	0.31	0.31	0.31	0.31	
		in.lb	2.7	2.7	2.7	2.7	2.7	2.7	2.7	2.7	2.7	2.7	2.7	2.7	2.7	2.7	2.7
Max. backlash	j_t	arcmin	≤ 12														
Torsional rigidity ^{b)}	C_{t21}	Nm/arcmin	3	3	3	3	3	3	3	3	3	3	3	3	3	3	
		in.lb/arcmin	27	27	27	27	27	27	27	27	27	27	27	27	27	27	27
Max. axial force ^{c)}	F_{2AMax}	N	1550														
		lb _f	349														
Max. lateral force ^{c)}	F_{2OMax}	N	1700														
		lb _f	383														
Max. tilting moment	M_{2KMMax}	Nm	72														
		in.lb	637														
Efficiency at full load	η	%	94														
Service life	L_h	h	> 20000														
Weight (incl. standard adapter plate)	m	kg	2.3														
		lb _m	5.1														
Operating noise (at reference ratio and reference speed – ratio-specific values available in cymex®)	L_{PA}	dB(A)	≤ 68														
Max. permitted housing temperature		°C	+90														
		°F	+194														
Ambient temperature		°C	0 to +40														
		°F	+32 to +104														
Lubrication			Lubricated for life														
Direction of rotation			In- and output same direction														
Protection class			IP 64														
Elastomer coupling (recommended product type – validate sizing with cymex®)			ELC-0060BA016.000-X														
Bore diameter of coupling on the application side		mm	X = 012.000 - 032.000														
Mass moment of inertia (relates to the drive) Clamping hub diameter [mm]	B	11	J_1	kgcm ²	0.13	0.13	0.13	0.13	0.13	0.13	0.13	0.13	0.13	0.13	0.13	0.13	0.13
				10 ⁻³ in.lb.s ²	0.12	0.12	0.12	0.12	0.12	0.12	0.12	0.12	0.12	0.12	0.12	0.12	0.12

Please use our sizing software cymex® for a detailed sizing – www.wittenstein-cymex.com
Please consider the maximal tilting moment caused by the motor M_{1KMot} – see sizing

^{a)} Valid for torque transmission only

^{b)} Valid for standard clamping hub diameter

^{c)} Refers to center of the output shaft or flange

^{d)} Please reduce input speed at higher ambient temperatures

^{e)} Valid for: Smooth shaft

Motor shaft diameter [mm]

3-stage

up to 11⁴⁾ (B)⁵⁾
clamping hub diameter

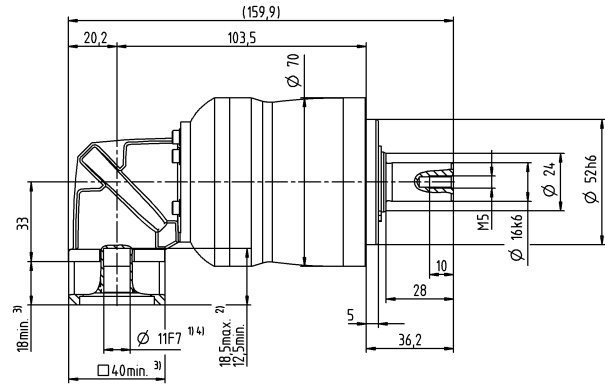
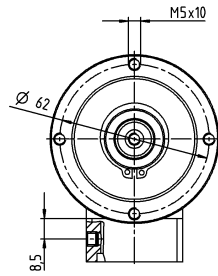

Other output variants

Shaft with key

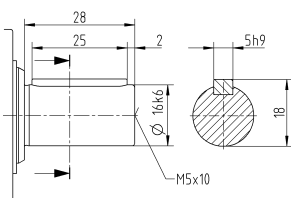

Non-tolerated dimensions are nominal dimensions

¹⁾ Check motor shaft fit

²⁾ Min. / Max. permissible motor shaft length

Longer motor shafts are possible, please contact alpha

³⁾ The dimensions depend on the motor

⁴⁾ Smaller motor shaft diameter is compensated

by a bushing with a minimum wall thickness of 1 mm

⁵⁾ Standard clamping hub diameter

NPK 025 MF 2-stage

			2-stage						
Ratio	i		3	4	5	7	8	10	
Max. torque ^{a) b) e)}	T_{2a}	Nm	60	80	100	140	144	144	
		in.lb	531	708	885	1239	1275	1275	
Max. acceleration torque ^{b)} (max. 1000 cycles per hour)	T_{2B}	Nm	35	47	58	82	90	90	
		in.lb	310	416	513	726	797	797	
Emergency stop torque ^{a) b) e)} (permitted 1000 times during the service life of the gearbox)	T_{2Not}	Nm	90	120	150	190	190	190	
		in.lb	797	1062	1328	1682	1682	1682	
Permitted average input speed ^{d)} (at T_{2a} and 20 °C ambient temperature)	n_{1N}	rpm	3000	3000	3000	3000	3000	3000	
Max. input speed	n_{1Max}	rpm	5000	5000	5000	5000	5000	5000	
Mean no load running torque ^{b)} (at $n_1=3000$ rpm and 20 °C gearbox temperature)	T_{012}	Nm	0.98	0.98	0.98	0.98	0.98	0.98	
		in.lb	8.7	8.7	8.7	8.7	8.7	8.7	
Max. backlash	j_t	arcmin	≤ 15						
Torsional rigidity ^{b)}	C_{t21}	Nm/arcmin	6.2	6.2	6.2	6.2	6.2	6.2	
		in.lb/arcmin	55	55	55	55	55	55	
Max. axial force ^{c)}	F_{2AMax}	N	1900						
		lb _f	428						
Max. lateral force ^{c)}	F_{2OMax}	N	2800						
		lb _f	630						
Max. tilting moment	M_{2KMMax}	Nm	137						
		in.lb	1213						
Efficiency at full load	η	%	95						
Service life	L_h	h	> 20000						
Weight (incl. standard adapter plate)	m	kg	4.9						
		lb _m	11						
Operating noise (at reference ratio and reference speed – ratio-specific values available in cymex®)	L_{PA}	dB(A)	≤ 73						
Max. permitted housing temperature		°C	+90						
		°F	+194						
Ambient temperature		°C	0 to +40						
		°F	+32 to +104						
Lubrication			Lubricated for life						
Direction of rotation			In- and output same direction						
Protection class			IP 64						
Elastomer coupling (recommended product type – validate sizing with cymex®)			ELC-0060BA022.000-X						
Bore diameter of coupling on the application side		mm	X = 012.000 - 032.000						
Mass moment of inertia (relates to the drive) Clamping hub diameter [mm]	E 19	J_1	kgcm ²	1.2	1.2	1.2	1.2	1.2	1.2
			10 ⁻³ in.lb.s ²	1.1	1.1	1.1	1.1	1.1	1.1

Please use our sizing software cymex® for a detailed sizing – www.wittenstein-cymex.com
Please consider the maximal tilting moment caused by the motor M_{1KMot} – see sizing

^{a)} Valid for torque transmission only

^{b)} Valid for standard clamping hub diameter

^{c)} Refers to center of the output shaft or flange

^{d)} Please reduce input speed at higher ambient temperatures

^{e)} Valid for: Smooth shaft

Motor shaft diameter [mm]

2-stage

up to 19⁴⁾ (E)⁵⁾
clamping hub diameter

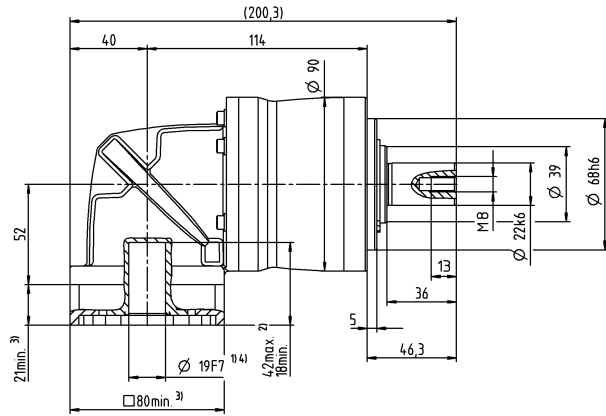
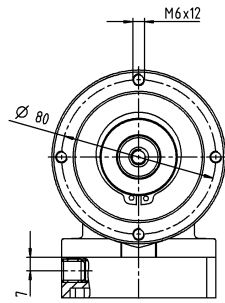

Other output variants

Shaft with key

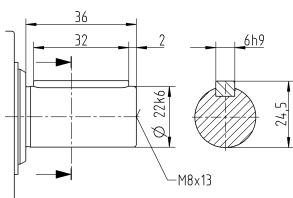

Non-tolerated dimensions are nominal dimensions

¹⁾ Check motor shaft fit

²⁾ Min. / Max. permissible motor shaft length

Longer motor shafts are possible, please contact alpha

³⁾ The dimensions depend on the motor

⁴⁾ Smaller motor shaft diameter is compensated by a bushing with a minimum wall thickness of 1 mm

⁵⁾ Standard clamping hub diameter

NPK 025 MF 3-stage

			3-stage														
Ratio	i		9	12	15	16	20	25	28	30	32	35	40	50	64	70	100
Max. torque ^{a) b) e)}	T_{2a}	Nm	99	128	128	152	152	160	152	128	152	160	152	160	144	160	144
		in.lb	876	1133	1133	1345	1345	1416	1345	1133	1345	1416	1345	1416	1275	1416	1275
Max. acceleration torque ^{b)} (max. 1000 cycles per hour)	T_{2B}	Nm	48	65	80	86	95	100	95	80	95	100	95	100	90	100	90
		in.lb	425	575	708	761	841	885	841	708	841	885	841	885	797	885	797
Emergency stop torque ^{a) b) e)} (permitted 1000 times during the service life of the gearbox)	T_{2Not}	Nm	124	166	190	190	190	190	190	190	190	190	190	190	190	190	190
		in.lb	1097	1469	1682	1682	1682	1682	1682	1682	1682	1682	1682	1682	1682	1682	1682
Permitted average input speed ^{d)} (at T_{2a} and 20 °C ambient temperature)	n_{1N}	rpm	3300	3300	3300	3300	3300	3300	3300	3300	3300	3300	3300	3300	3300	3300	3300
Max. input speed	n_{1Max}	rpm	5000	5000	5000	5000	5000	5000	5000	5000	5000	5000	5000	5000	5000	5000	5000
Mean no load running torque ^{b)} (at $n_1=3000$ rpm and 20 °C gearbox temperature)	T_{012}	Nm	0.52	0.52	0.52	0.52	0.52	0.52	0.52	0.52	0.52	0.52	0.52	0.52	0.52	0.52	0.52
		in.lb	4.6	4.6	4.6	4.6	4.6	4.6	4.6	4.6	4.6	4.6	4.6	4.6	4.6	4.6	4.6
Max. backlash	j_t	arcmin	≤ 13														
Torsional rigidity ^{b)}	C_{t21}	Nm/arcmin	8.4	8.4	8.4	8.4	8.4	8.4	8.4	8.4	8.4	8.4	8.4	8.4	8.4	8.4	8.4
		in.lb/arcmin	74	74	74	74	74	74	74	74	74	74	74	74	74	74	74
Max. axial force ^{c)}	F_{2AMax}	N	1900														
		lb _f	428														
Max. lateral force ^{c)}	F_{2OMax}	N	2800														
		lb _f	630														
Max. tilting moment	M_{2KMMax}	Nm	137														
		in.lb	1213														
Efficiency at full load	η	%	94														
Service life	L_h	h	> 20000														
Weight (incl. standard adapter plate)	m	kg	4.5														
		lb _m	9.9														
Operating noise (at reference ratio and reference speed – ratio-specific values available in cymex®)	L_{PA}	dB(A)	≤ 70														
Max. permitted housing temperature		°C	+90														
		°F	+194														
Ambient temperature		°C	0 to +40														
		°F	+32 to +104														
Lubrication			Lubricated for life														
Direction of rotation			In- and output same direction														
Protection class			IP 64														
Elastomer coupling (recommended product type – validate sizing with cymex®)			ELC-0060BA022.000-X														
Bore diameter of coupling on the application side		mm	X = 012.000 - 032.000														
Mass moment of inertia (relates to the drive) Clamping hub diameter [mm]	C	14	J_1	kgcm ²	0.45	0.45	0.45	0.45	0.45	0.45	0.45	0.45	0.45	0.45	0.45	0.45	0.45
				10 ⁻³ in.lb.s ²	0.4	0.4	0.4	0.4	0.4	0.4	0.4	0.4	0.4	0.4	0.4	0.4	0.4

Please use our sizing software cymex® for a detailed sizing – www.wittenstein-cymex.com
Please consider the maximal tilting moment caused by the motor M_{1KMot} – see sizing

^{a)} Valid for torque transmission only

^{b)} Valid for standard clamping hub diameter

^{c)} Refers to center of the output shaft or flange

^{d)} Please reduce input speed at higher ambient temperatures

^{e)} Valid for: Smooth shaft

Motor shaft diameter [mm]

3-stage

up to 14⁴⁾ (C)⁵⁾
clamping hub diameter

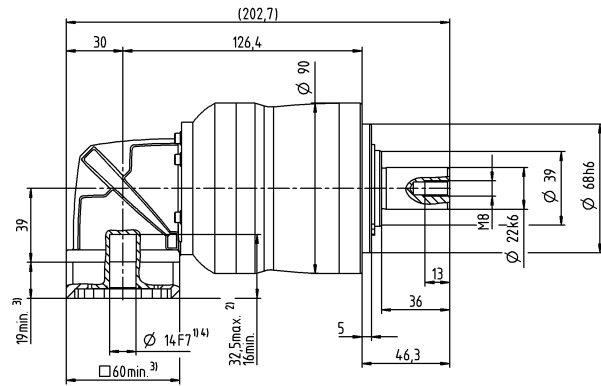
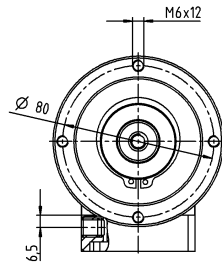

Other output variants

Shaft with key

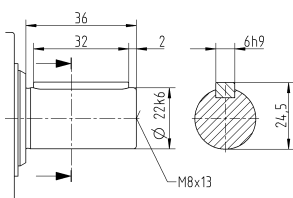

Non-tolerated dimensions are nominal dimensions

¹⁾ Check motor shaft fit

²⁾ Min. / Max. permissible motor shaft length

Longer motor shafts are possible, please contact alpha

³⁾ The dimensions depend on the motor

⁴⁾ Smaller motor shaft diameter is compensated

by a bushing with a minimum wall thickness of 1 mm

⁵⁾ Standard clamping hub diameter

NPK 035 MF 2-stage

			2-stage						
Ratio	i		3	4	5	7	8	10	
Max. torque ^{a) b) e)}	T_{2a}	Nm	150	200	250	350	352	352	
		in.lb	1328	1770	2213	3098	3115	3115	
Max. acceleration torque ^{b)} (max. 1000 cycles per hour)	T_{2B}	Nm	93	124	155	217	220	220	
		in.lb	823	1097	1372	1921	1947	1947	
Emergency stop torque ^{a) b) e)} (permitted 1000 times during the service life of the gearbox)	T_{2Not}	Nm	238	318	397	500	500	500	
		in.lb	2106	2815	3514	4425	4425	4425	
Permitted average input speed ^{d)} (at T_{2a} and 20 °C ambient temperature)	n_{1N}	rpm	2000	2000	2000	2000	2000	2000	
Max. input speed	n_{1Max}	rpm	4500	4500	4500	4500	4500	4500	
Mean no load running torque ^{b)} (at $n_1=3000$ rpm and 20 °C gearbox temperature)	T_{012}	Nm	3.5	3.5	3.5	3.5	3.5	3.5	
		in.lb	31	31	31	31	31	31	
Max. backlash	j_t	arcmin	≤ 13						
Torsional rigidity ^{b)}	C_{t21}	Nm/arcmin	16	16	16	16	16	16	
		in.lb/arcmin	142	142	142	142	142	142	
Max. axial force ^{c)}	F_{2AMax}	N	4000						
		lb _f	900						
Max. lateral force ^{c)}	F_{2OMax}	N	5000						
		lb _f	1125						
Max. tilting moment	M_{2KMMax}	Nm	345						
		in.lb	3054						
Efficiency at full load	η	%	95						
Service life	L_h	h	> 20000						
Weight (incl. standard adapter plate)	m	kg	11						
		lb _m	24						
Operating noise (at reference ratio and reference speed – ratio-specific values available in cymex®)	L_{PA}	dB(A)	≤ 74						
Max. permitted housing temperature		°C	+90						
		°F	+194						
Ambient temperature		°C	0 to +40						
		°F	+32 to +104						
Lubrication			Lubricated for life						
Direction of rotation			In- and output same direction						
Protection class			IP 64						
Elastomer coupling (recommended product type – validate sizing with cymex®)			ELC-0150BA032.000-X						
Bore diameter of coupling on the application side		mm	X = 019.000 - 036.000						
Mass moment of inertia (relates to the drive) Clamping hub diameter [mm]	H 28	J_1	kgcm ²	5.3	5.3	5.3	5.3	5.3	5.3
			10 ⁻³ in.lb.s ²	4.7	4.7	4.7	4.7	4.7	4.7

Please use our sizing software cymex® for a detailed sizing – www.wittenstein-cymex.com
Please consider the maximal tilting moment caused by the motor M_{1KMot} – see sizing

^{a)} Valid for torque transmission only

^{b)} Valid for standard clamping hub diameter

^{c)} Refers to center of the output shaft or flange

^{d)} Please reduce input speed at higher ambient temperatures

^{e)} Valid for: Smooth shaft

Motor shaft diameter [mm]

2-stage

up to 28⁴⁾ (H)⁵⁾
clamping hub diameter

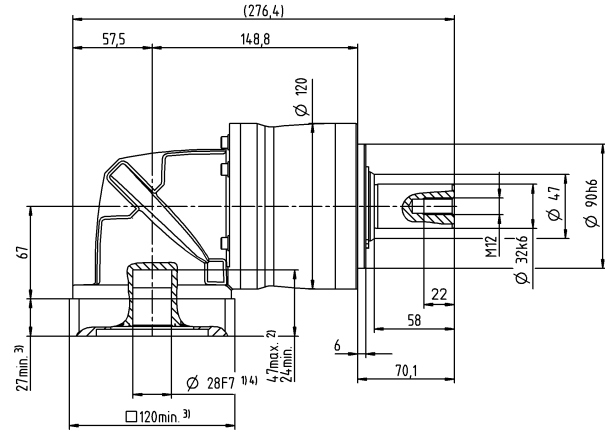
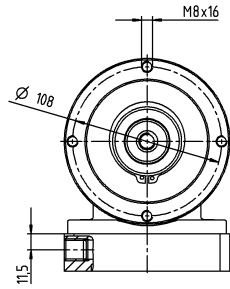

Other output variants

Shaft with key

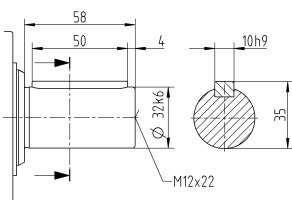

Non-tolerated dimensions are nominal dimensions

¹⁾ Check motor shaft fit

²⁾ Min. / Max. permissible motor shaft length

Longer motor shafts are possible, please contact alpha

³⁾ The dimensions depend on the motor

⁴⁾ Smaller motor shaft diameter is compensated

by a bushing with a minimum wall thickness of 1 mm

⁵⁾ Standard clamping hub diameter

NPK 035 MF 3-stage

			3-stage														
Ratio	i		9	12	15	16	20	25	28	30	32	35	40	50	64	70	100
Max. torque ^{a) b) e)}	T_{2a}	Nm	180	240	300	320	400	400	408	320	408	400	408	400	352	400	352
		in.lb	1593	2124	2655	2832	3540	3540	3611	2832	3611	3540	3611	3540	3115	3540	3115
Max. acceleration torque ^{b)} (max. 1000 cycles per hour)	T_{2B}	Nm	105	141	176	188	235	250	255	200	255	250	255	250	220	250	220
		in.lb	929	1248	1558	1664	2080	2213	2257	1770	2257	2213	2257	2213	1947	2213	1947
Emergency stop torque ^{a) b) e)} (permitted 1000 times during the service life of the gearbox)	T_{2Not}	Nm	270	361	451	481	500	500	500	500	500	500	500	500	500	500	500
		in.lb	2390	3195	3992	4257	4425	4425	4425	4425	4425	4425	4425	4425	4425	4425	4425
Permitted average input speed ^{d)} (at T_{2a} and 20 °C ambient temperature)	n_{1N}	rpm	3000	3000	3000	3000	3000	3000	3000	3000	3000	3000	3000	3000	3000	3000	3000
Max. input speed	n_{1Max}	rpm	5000	5000	5000	5000	5000	5000	5000	5000	5000	5000	5000	5000	5000	5000	5000
Mean no load running torque ^{b)} (at $n_1=3000$ rpm and 20 °C gearbox temperature)	T_{012}	Nm	1	1	1	1	1	1	1	1	1	1	1	1	1	1	1
		in.lb	8.9	8.9	8.9	8.9	8.9	8.9	8.9	8.9	8.9	8.9	8.9	8.9	8.9	8.9	8.9
Max. backlash	j_t	arcmin	≤ 13														
Torsional rigidity ^{b)}	C_{121}	Nm/arcmin	19	19	19	19	19	19	19	19	19	19	19	19	19	19	19
		in.lb/arcmin	168	168	168	168	168	168	168	168	168	168	168	168	168	168	168
Max. axial force ^{c)}	F_{2AMax}	N	4000														
		lb _f	900														
Max. lateral force ^{c)}	F_{2OMax}	N	5000														
		lb _f	1125														
Max. tilting moment	M_{2KMax}	Nm	345														
		in.lb	3054														
Efficiency at full load	η	%	94														
Service life	L_h	h	> 20000														
Weight (incl. standard adapter plate)	m	kg	11														
		lb _m	24														
Operating noise (at reference ratio and reference speed – ratio-specific values available in cymex®)	L_{PA}	dB(A)	≤ 73														
Max. permitted housing temperature		°C	+90														
		°F	+194														
Ambient temperature		°C	0 to +40														
		°F	+32 to +104														
Lubrication			Lubricated for life														
Direction of rotation			In- and output same direction														
Protection class			IP 64														
Elastomer coupling (recommended product type – validate sizing with cymex®)			ELC-0150BA032.000-X														
Bore diameter of coupling on the application side		mm	X = 019.000 - 036.000														
Mass moment of inertia (relates to the drive) Clamping hub diameter [mm]	E	19	J_1	kgcm ²	1.7	1.7	1.7	1.7	1.7	1.7	1.7	1.7	1.7	1.7	1.7	1.7	1.7
				10 ⁻³ in.lb.s ²	1.5	1.5	1.5	1.5	1.5	1.5	1.5	1.5	1.5	1.5	1.5	1.5	1.5

Please use our sizing software cymex® for a detailed sizing – www.wittenstein-cymex.com
Please consider the maximal tilting moment caused by the motor M_{1KMot} – see sizing

^{a)} Valid for torque transmission only

^{b)} Valid for standard clamping hub diameter

^{c)} Refers to center of the output shaft or flange

^{d)} Please reduce input speed at higher ambient temperatures

^{e)} Valid for: Smooth shaft

Motor shaft diameter [mm]

3-stage

up to 19⁴⁾ (E)⁵⁾
clamping hub
diameter

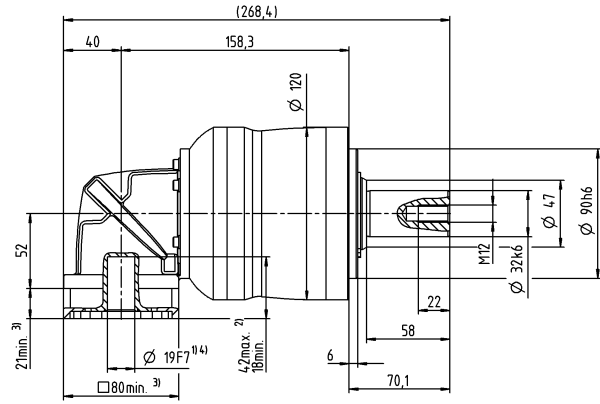
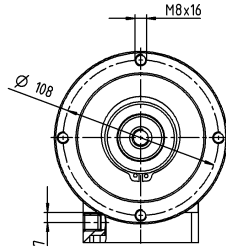

Other output variants

Shaft with key

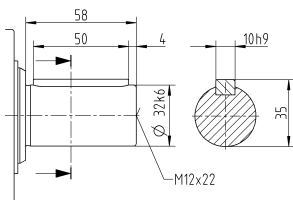

Non-tolerated dimensions are nominal dimensions

¹⁾ Check motor shaft fit

²⁾ Min. / Max. permissible motor shaft length

Longer motor shafts are possible, please contact alpha

³⁾ The dimensions depend on the motor

⁴⁾ Smaller motor shaft diameter is compensated by a bushing with a minimum wall thickness of 1 mm

⁵⁾ Standard clamping hub diameter

NPK 045 MF 3-stage

			3-stage					
Ratio	i		25	32	50	64	100	
Max. torque ^{a) b) e)}	T_{2a}	Nm	700	640	700	640	640	
		in.lb	6196	5665	6196	5665	5665	
Max. acceleration torque ^{e)} (max. 1000 cycles per hour)	T_{2B}	Nm	500	400	500	400	400	
		in.lb	4425	3540	4425	3540	3540	
Emergency stop torque ^{a) b) e)} (permitted 1000 times during the service life of the gearbox)	T_{2Not}	Nm	1000	1000	1000	1000	1000	
		in.lb	8851	8851	8851	8851	8851	
Permitted average input speed ^{d)} (at T_{2N} and 20 °C ambient temperature)	n_{1N}	rpm	2000	2000	2000	2000	2000	
Max. input speed	n_{1Max}	rpm	4500	4500	4500	4500	4500	
Mean no load running torque ^{b)} (at $n_1=3000$ rpm and 20 °C gearbox temperature)	T_{012}	Nm	3.6	3.6	3.6	3.6	3.6	
		in.lb	32	32	32	32	32	
Max. backlash	j_i	arcmin	≤ 11					
Torsional rigidity ^{b)}	C_{121}	Nm/arcmin	54	54	54	54	54	
		in.lb/arcmin	478	478	478	478	478	
Max. axial force ^{c)}	F_{2AMax}	N	6000					
		lb _f	1350					
Max. lateral force ^{c)}	F_{2QMMax}	N	8000					
		lb _f	1800					
Max. tilting moment	M_{2KMMax}	Nm	704					
		in.lb	6231					
Efficiency at full load	η	%	94					
Service life	L_n	h	> 20000					
Weight (incl. standard adapter plate)	m	kg	21					
		lb _m	46					
Operating noise (at reference ratio and reference speed – ratio-specific values available in cymex®)	L_{PA}	dB(A)	≤ 74					
Max. permitted housing temperature		°C	+90					
		°F	+194					
Ambient temperature		°C	0 to +40					
		°F	+32 to +104					
Lubrication			Lubricated for life					
Direction of rotation			In- and output same direction					
Protection class			IP 64					
Elastomer coupling (recommended product type – validate sizing with cymex®)			ELC-0300BA040.000-X					
Bore diameter of coupling on the application side		mm	X = 020.000 - 045.000					
Mass moment of inertia (relates to the drive) Clamping hub diameter [mm]	H 28	J_1	kgcm ²	6.8	6.8	6.8	6.8	6.8
			10 ⁻³ in.lb.s ²	6	6	6	6	6

Please use our sizing software cymex® for a detailed sizing – www.wittenstein-cymex.com
Please consider the maximal tilting moment caused by the motor M_{1KMot} – see sizing

^{a)} Valid for torque transmission only

^{b)} Valid for standard clamping hub diameter

^{c)} Refers to center of the output shaft or flange

^{d)} Please reduce input speed at higher ambient temperatures

^{e)} Valid for: Smooth shaft

Motor shaft diameter [mm]

3-stage

up to 28⁴⁾ (H)⁵⁾
clamping hub diameter

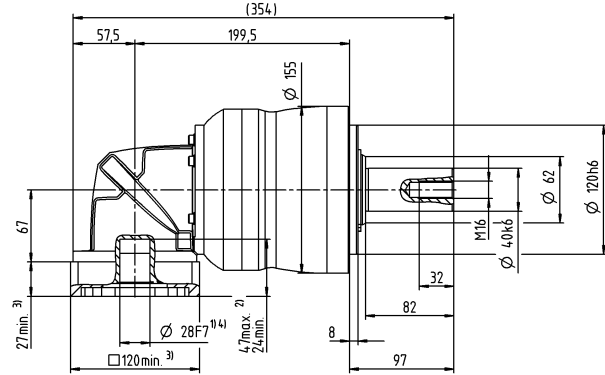
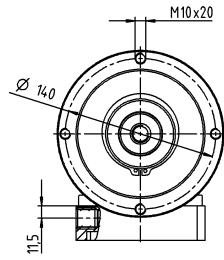

Other output variants

Shaft with key

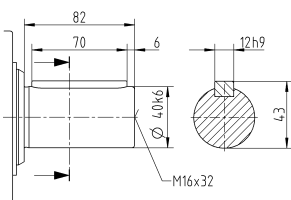

Non-tolerated dimensions are nominal dimensions

¹⁾ Check motor shaft fit

²⁾ Min. / Max. permissible motor shaft length

Longer motor shafts are possible, please contact alpha

³⁾ The dimensions depend on the motor

⁴⁾ Smaller motor shaft diameter is compensated by a bushing with a minimum wall thickness of 1 mm

⁵⁾ Standard clamping hub diameter

NPLK 015 MF 2-stage

			2-stage							
Ratio	i		3	4	5	7	8	10		
Max. torque ^{a) b) e)}	T_{2a}	Nm	33	44	55	64	56	56		
		in.lb	292	389	487	566	496	496		
Max. acceleration torque ^{b)} (max. 1000 cycles per hour)	T_{2B}	Nm	16	21	27	37	35	35		
		in.lb	142	186	239	327	310	310		
Emergency stop torque ^{a) b) e)} (permitted 1000 times during the service life of the gearbox)	T_{2Not}	Nm	41	55	69	80	80	80		
		in.lb	363	487	611	708	708	708		
Permitted average input speed ^{d)} (at T_{2a} and 20 °C ambient temperature)	n_{1N}	rpm	2900	3100	3300	3300	3300	3300		
Max. input speed	n_{1Max}	rpm	5000	5000	5000	5000	5000	5000		
Mean no load running torque ^{b)} (at $n_1=3000$ rpm and 20 °C gearbox temperature)	T_{012}	Nm	1.2	1.2	1.2	1.2	1.2	1.2		
		in.lb	11	11	11	11	11	11		
Max. backlash	j_t	arcmin	≤ 15							
Torsional rigidity ^{b)}	C_{t21}	Nm/arcmin	2.4	2.4	2.4	2.4	2.4	2.4		
		in.lb/arcmin	21	21	21	21	21	21		
Max. axial force ^{c)}	F_{2AMax}	N	2400							
		lb _f	540							
Max. lateral force ^{c)}	F_{2OMax}	N	2800							
		lb _f	630							
Max. tilting moment	M_{2KMMax}	Nm	152							
		in.lb	1345							
Efficiency at full load	η	%	95							
Service life	L_h	h	> 20000							
Weight (incl. standard adapter plate)	m	kg	2.3							
		lb _m	5.1							
Operating noise (at reference ratio and reference speed – ratio-specific values available in cymex®)	L_{PA}	dB(A)	≤ 70							
Max. permitted housing temperature		°C	+90							
		°F	+194							
Ambient temperature		°C	0 to +40							
		°F	+32 to +104							
Lubrication			Lubricated for life							
Direction of rotation			In- and output same direction							
Protection class			IP 64							
Elastomer coupling (recommended product type – validate sizing with cymex®)			ELC-0060BA016.000-X							
Bore diameter of coupling on the application side		mm	X = 012.000 - 032.000							
Mass moment of inertia (relates to the drive) Clamping hub diameter [mm]	C	14	J_1	kgcm ²	0.32	0.32	0.32	0.32	0.32	0.32
				10 ⁻³ in.lb.s ²	0.28	0.28	0.28	0.28	0.28	0.28

Please use our sizing software cymex® for a detailed sizing – www.wittenstein-cymex.com
Please consider the maximal tilting moment caused by the motor M_{1KMot} – see sizing

^{a)} Valid for torque transmission only

^{b)} Valid for standard clamping hub diameter

^{c)} Refers to center of the output shaft or flange

^{d)} Please reduce input speed at higher ambient temperatures

^{e)} Valid for: Smooth shaft

Motor shaft diameter [mm]

2-stage

up to 14⁴⁾ (C)⁵⁾
clamping hub diameter

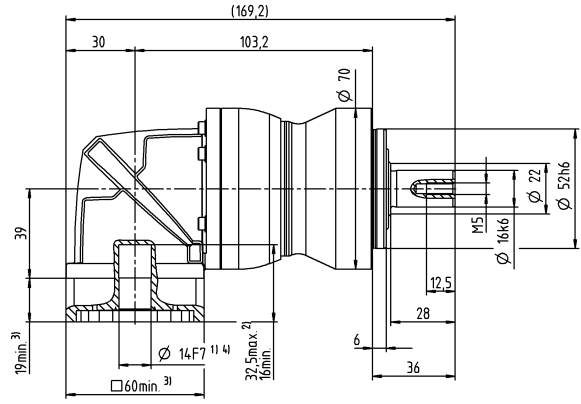
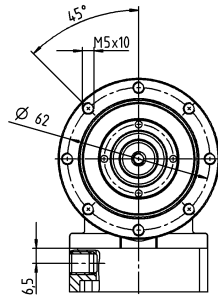

Other output variants

Shaft with key

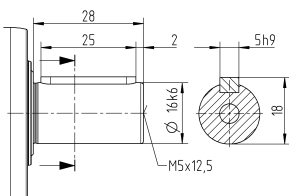

Splined shaft (DIN 5480)

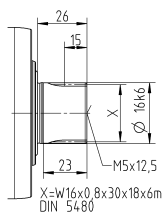

Non-tolerated dimensions are nominal dimensions

¹⁾ Check motor shaft fit

²⁾ Min. / Max. permissible motor shaft length

Longer motor shafts are possible, please contact alpha

³⁾ The dimensions depend on the motor

⁴⁾ Smaller motor shaft diameter is compensated

by a bushing with a minimum wall thickness of 1 mm

⁵⁾ Standard clamping hub diameter

NPLK 015 MF 3-stage

			3-stage														
Ratio	i		12	15	16	20	25	28	30	32	35	40	50	64	70	100	
Max. torque ^{a) b) e)}	T_{2a}	Nm	42	51	56	56	64	56	51	56	64	56	64	56	64	56	
		in.lb	372	451	496	496	566	496	451	496	566	496	566	496	566	496	
Max. acceleration torque ^{b)} (max. 1000 cycles per hour)	T_{2B}	Nm	20	25	27	34	40	35	31	35	40	35	40	35	40	35	
		in.lb	177	221	239	301	354	310	274	310	354	310	354	310	354	310	
Emergency stop torque ^{a) b) e)} (permitted 1000 times during the service life of the gearbox)	T_{2Not}	Nm	52	65	70	80	80	80	80	80	80	80	80	80	80	80	
		in.lb	460	575	620	708	708	708	708	708	708	708	708	708	708	708	
Permitted average input speed ^{d)} (at T_{2a} and 20 °C ambient temperature)	n_{1N}	rpm	3800	3800	3800	3800	3800	3800	3800	3800	3800	3800	3800	3800	3800	3800	
Max. input speed	n_{1Max}	rpm	5000	5000	5000	5000	5000	5000	5000	5000	5000	5000	5000	5000	5000	5000	
Mean no load running torque ^{b)} (at $n_1 = 3000$ rpm and 20 °C gearbox temperature)	T_{012}	Nm	0.52	0.52	0.52	0.52	0.52	0.52	0.52	0.52	0.52	0.52	0.52	0.52	0.52	0.52	
		in.lb	4.6	4.6	4.6	4.6	4.6	4.6	4.6	4.6	4.6	4.6	4.6	4.6	4.6	4.6	
Max. backlash	j_t	arcmin	≤ 12														
Torsional rigidity ^{b)}	C_{t21}	Nm/arcmin	3	3	3	3	3	3	3	3	3	3	3	3	3	3	
		in.lb/arcmin	27	27	27	27	27	27	27	27	27	27	27	27	27	27	
Max. axial force ^{c)}	F_{2AMax}	N	2400														
		lb _f	540														
Max. lateral force ^{c)}	F_{2OMax}	N	2800														
		lb _f	630														
Max. tilting moment	M_{2KMMax}	Nm	152														
		in.lb	1345														
Efficiency at full load	η	%	94														
Service life	L_h	h	> 20000														
Weight (incl. standard adapter plate)	m	kg	2.4														
		lb _m	5.3														
Operating noise (at reference ratio and reference speed – ratio-specific values available in cymex®)	L_{PA}	dB(A)	≤ 68														
Max. permitted housing temperature		°C	+90														
		°F	+194														
Ambient temperature		°C	0 to +40														
		°F	+32 to +104														
Lubrication			Lubricated for life														
Direction of rotation			In- and output same direction														
Protection class			IP 64														
Elastomer coupling (recommended product type – validate sizing with cymex®)			ELC-0060BA016.000-X														
Bore diameter of coupling on the application side		mm	X = 012.000 - 032.000														
Mass moment of inertia (relates to the drive) Clamping hub diameter [mm]	B	11	J_1	kgcm ²	0.14	0.14	0.14	0.14	0.14	0.14	0.14	0.14	0.14	0.14	0.14	0.14	0.14
				10 ⁻³ in.lb.s ²	0.12	0.12	0.12	0.12	0.12	0.12	0.12	0.12	0.12	0.12	0.12	0.12	0.12

Please use our sizing software cymex® for a detailed sizing – www.wittenstein-cymex.com
Please consider the maximal tilting moment caused by the motor M_{1KMot} – see sizing

^{a)} Valid for torque transmission only

^{b)} Valid for standard clamping hub diameter

^{c)} Refers to center of the output shaft or flange

^{d)} Please reduce input speed at higher ambient temperatures

^{e)} Valid for: Smooth shaft

Motor shaft diameter [mm]

3-stage

up to 11⁴⁾ (B)⁵⁾
clamping hub diameter

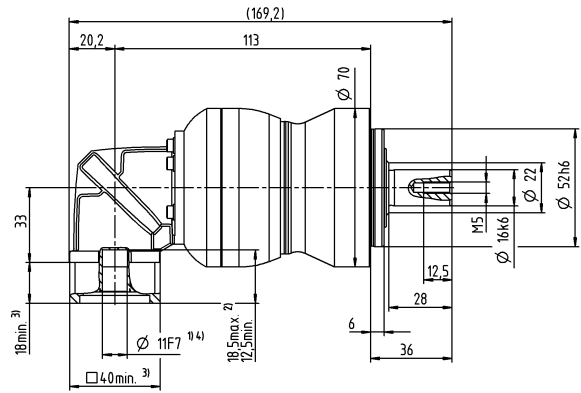
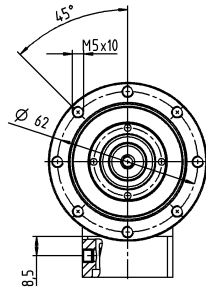

Other output variants

Shaft with key

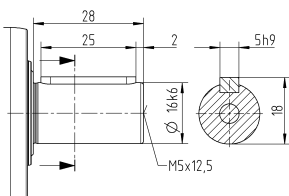

Splined shaft (DIN 5480)

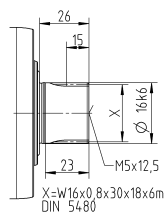

Non-tolerated dimensions are nominal dimensions

¹⁾ Check motor shaft fit

²⁾ Min. / Max. permissible motor shaft length

Longer motor shafts are possible, please contact alpha

³⁾ The dimensions depend on the motor

⁴⁾ Smaller motor shaft diameter is compensated

by a bushing with a minimum wall thickness of 1 mm

⁵⁾ Standard clamping hub diameter

NPLK 025 MF 2-stage

			2-stage						
Ratio	i		3	4	5	7	8	10	
Max. torque ^{a) b) e)}	T_{2a}	Nm	60	80	100	140	144	144	
		in.lb	531	708	885	1239	1275	1275	
Max. acceleration torque ^{b)} (max. 1000 cycles per hour)	T_{2B}	Nm	35	47	58	82	90	90	
		in.lb	310	416	513	726	797	797	
Emergency stop torque ^{a) b) e)} (permitted 1000 times during the service life of the gearbox)	T_{2Not}	Nm	90	120	150	190	190	190	
		in.lb	797	1062	1328	1682	1682	1682	
Permitted average input speed ^{d)} (at T_{2a} and 20 °C ambient temperature)	n_{1N}	rpm	2700	2900	3000	3000	3000	3000	
Max. input speed	n_{1Max}	rpm	5000	5000	5000	5000	5000	5000	
Mean no load running torque ^{b)} (at $n_1=3000$ rpm and 20 °C gearbox temperature)	T_{012}	Nm	2.4	2.4	2.4	2.4	2.4	2.4	
		in.lb	21	21	21	21	21	21	
Max. backlash	j_t	arcmin	≤ 15						
Torsional rigidity ^{b)}	C_{t21}	Nm/arcmin	6.2	6.2	6.2	6.2	6.2	6.2	
		in.lb/arcmin	55	55	55	55	55	55	
Max. axial force ^{c)}	F_{2AMax}	N	3350						
		lb _f	754						
Max. lateral force ^{c)}	F_{2OMax}	N	4200						
		lb _f	945						
Max. tilting moment	M_{2KMMax}	Nm	236						
		in.lb	2089						
Efficiency at full load	η	%	95						
Service life	L_h	h	> 20000						
Weight (incl. standard adapter plate)	m	kg	5						
		lb _m	11						
Operating noise (at reference ratio and reference speed – ratio-specific values available in cymex®)	L_{PA}	dB(A)	≤ 73						
Max. permitted housing temperature		°C	+90						
		°F	+194						
Ambient temperature		°C	0 to +40						
		°F	+32 to +104						
Lubrication			Lubricated for life						
Direction of rotation			In- and output same direction						
Protection class			IP 64						
Elastomer coupling (recommended product type – validate sizing with cymex®)			ELC-0060BA022.000-X						
Bore diameter of coupling on the application side		mm	X = 012.000 - 032.000						
Mass moment of inertia (relates to the drive) Clamping hub diameter [mm]	E 19	J_1	kgcm ²	1.2	1.2	1.2	1.2	1.2	1.2
			10 ⁻³ in.lb.s ²	1.1	1.1	1.1	1.1	1.1	1.1

Please use our sizing software cymex® for a detailed sizing – www.wittenstein-cymex.com
Please consider the maximal tilting moment caused by the motor M_{1KMot} – see sizing

^{a)} Valid for torque transmission only

^{b)} Valid for standard clamping hub diameter

^{c)} Refers to center of the output shaft or flange

^{d)} Please reduce input speed at higher ambient temperatures

^{e)} Valid for: Smooth shaft

Motor shaft diameter [mm]

2-stage

up to 19⁴⁾ (E)⁵⁾
clamping hub diameter

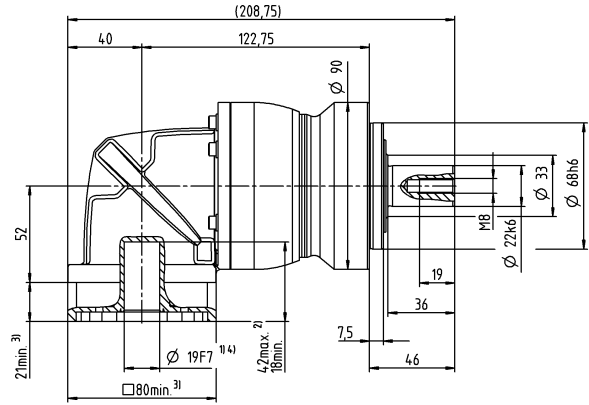
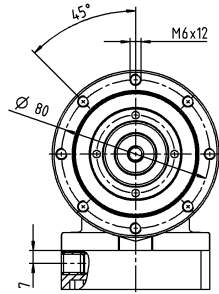

Other output variants

Shaft with key

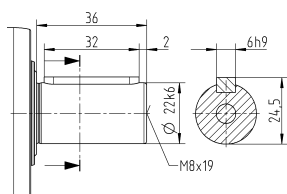

Splined shaft (DIN 5480)

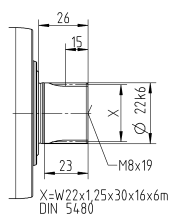

Non-tolerated dimensions are nominal dimensions

¹⁾ Check motor shaft fit

²⁾ Min. / Max. permissible motor shaft length

Longer motor shafts are possible, please contact alpha

³⁾ The dimensions depend on the motor

⁴⁾ Smaller motor shaft diameter is compensated

by a bushing with a minimum wall thickness of 1 mm

⁵⁾ Standard clamping hub diameter

NPLK 025 MF 3-stage

			3-stage														
Ratio	i		9	12	15	16	20	25	28	30	32	35	40	50	64	70	100
Max. torque ^{a) b) e)}	T_{2a}	Nm	99	128	128	152	152	160	152	128	152	160	152	160	144	160	144
		in.lb	876	1133	1133	1345	1345	1416	1345	1133	1345	1416	1345	1416	1275	1416	1275
Max. acceleration torque ^{b)} (max. 1000 cycles per hour)	T_{2B}	Nm	48	65	80	86	95	100	95	80	95	100	95	100	90	100	90
		in.lb	425	575	708	761	841	885	841	708	841	885	841	885	797	885	797
Emergency stop torque ^{a) b) e)} (permitted 1000 times during the service life of the gearbox)	T_{2Not}	Nm	124	166	190	190	190	190	190	190	190	190	190	190	190	190	190
		in.lb	1097	1469	1682	1682	1682	1682	1682	1682	1682	1682	1682	1682	1682	1682	1682
Permitted average input speed ^{d)} (at T_{2a} and 20 °C ambient temperature)	n_{1N}	rpm	2900	3300	3300	3300	3300	3300	3300	3300	3300	3300	3300	3300	3300	3300	
Max. input speed	n_{1Max}	rpm	5000	5000	5000	5000	5000	5000	5000	5000	5000	5000	5000	5000	5000	5000	
Mean no load running torque ^{b)} (at $n_1=3000$ rpm and 20 °C gearbox temperature)	T_{012}	Nm	0.97	0.97	0.97	0.97	0.97	0.97	0.97	0.97	0.97	0.97	0.97	0.97	0.97	0.97	
		in.lb	8.6	8.6	8.6	8.6	8.6	8.6	8.6	8.6	8.6	8.6	8.6	8.6	8.6	8.6	
Max. backlash	j_t	arcmin	≤ 13														
Torsional rigidity ^{b)}	C_{121}	Nm/arcmin	8.4	8.4	8.4	8.4	8.4	8.4	8.4	8.4	8.4	8.4	8.4	8.4	8.4	8.4	
		in.lb/arcmin	74	74	74	74	74	74	74	74	74	74	74	74	74	74	
Max. axial force ^{c)}	F_{2AMax}	N	3350														
		lb _f	754														
Max. lateral force ^{c)}	F_{2OMax}	N	4200														
		lb _f	945														
Max. tilting moment	M_{2KMMax}	Nm	236														
		in.lb	2089														
Efficiency at full load	η	%	94														
Service life	L_h	h	> 20000														
Weight (incl. standard adapter plate)	m	kg	4.6														
		lb _m	10														
Operating noise (at reference ratio and reference speed – ratio-specific values available in cymex®)	L_{PA}	dB(A)	≤ 73														
Max. permitted housing temperature		°C	+90														
		°F	+194														
Ambient temperature		°C	0 to +40														
		°F	+32 to +104														
Lubrication			Lubricated for life														
Direction of rotation			In- and output same direction														
Protection class			IP 64														
Elastomer coupling (recommended product type – validate sizing with cymex®)			ELC-0060BA022.000-X														
Bore diameter of coupling on the application side		mm	X = 012.000 - 032.000														
Mass moment of inertia (relates to the drive) Clamping hub diameter [mm]	C	14	J_1	kgcm ²	0.45	0.45	0.45	0.45	0.45	0.45	0.45	0.45	0.45	0.45	0.45	0.45	0.45
				10 ⁻³ in.lb.s ²	0.4	0.4	0.4	0.4	0.4	0.4	0.4	0.4	0.4	0.4	0.4	0.4	0.4

Please use our sizing software cymex® for a detailed sizing – www.wittenstein-cymex.com
Please consider the maximal tilting moment caused by the motor M_{1KMot} – see sizing

^{a)} Valid for torque transmission only

^{b)} Valid for standard clamping hub diameter

^{c)} Refers to center of the output shaft or flange

^{d)} Please reduce input speed at higher ambient temperatures

^{e)} Valid for: Smooth shaft

Motor shaft diameter [mm]

3-stage

up to 14⁴⁾ (C)⁵⁾
clamping hub diameter

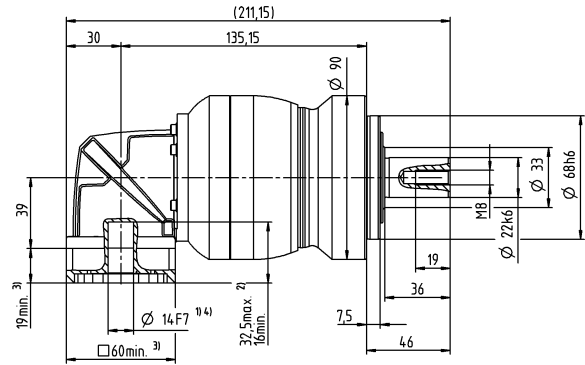
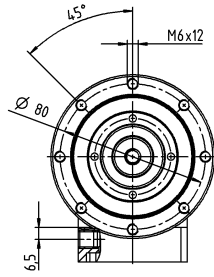

Other output variants

Shaft with key

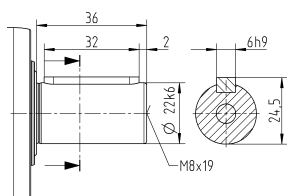

Splined shaft (DIN 5480)

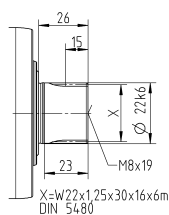

Non-tolerated dimensions are nominal dimensions

¹⁾ Check motor shaft fit

²⁾ Min. / Max. permissible motor shaft length

Longer motor shafts are possible, please contact alpha

³⁾ The dimensions depend on the motor

⁴⁾ Smaller motor shaft diameter is compensated

by a bushing with a minimum wall thickness of 1 mm

⁵⁾ Standard clamping hub diameter

NPLK 035 MF 2-stage

			2-stage						
Ratio	i		3	4	5	7	8	10	
Max. torque ^{a) b) e)}	T_{2a}	Nm	150	200	250	350	352	352	
		in.lb	1328	1770	2213	3098	3115	3115	
Max. acceleration torque ^{b)} (max. 1000 cycles per hour)	T_{2B}	Nm	93	124	155	217	220	220	
		in.lb	823	1097	1372	1921	1947	1947	
Emergency stop torque ^{a) b) e)} (permitted 1000 times during the service life of the gearbox)	T_{2Not}	Nm	238	318	397	500	500	500	
		in.lb	2106	2815	3514	4425	4425	4425	
Permitted average input speed ^{d)} (at T_{2a} and 20 °C ambient temperature)	n_{1N}	rpm	2000	2000	2000	2000	2000	2000	
Max. input speed	n_{1Max}	rpm	4500	4500	4500	4500	4500	4500	
Mean no load running torque ^{b)} (at $n_1=3000$ rpm and 20 °C gearbox temperature)	T_{012}	Nm	5.8	5.8	5.8	5.8	5.8	5.8	
		in.lb	51	51	51	51	51	51	
Max. backlash	j_t	arcmin	≤ 13						
Torsional rigidity ^{b)}	C_{121}	Nm/arcmin	16	16	16	16	16	16	
		in.lb/arcmin	142	142	142	142	142	142	
Max. axial force ^{c)}	F_{2AMax}	N	5650						
		lb _f	1271						
Max. lateral force ^{c)}	F_{2OMax}	N	6600						
		lb _f	1485						
Max. tilting moment	M_{2KMMax}	Nm	487						
		in.lb	4310						
Efficiency at full load	η	%	95						
Service life	L_h	h	> 20000						
Weight (incl. standard adapter plate)	m	kg	11						
		lb _m	24						
Operating noise (at reference ratio and reference speed – ratio-specific values available in cymex®)	L_{PA}	dB(A)	≤ 74						
Max. permitted housing temperature		°C	+90						
		°F	+194						
Ambient temperature		°C	0 to +40						
		°F	+32 to +104						
Lubrication			Lubricated for life						
Direction of rotation			In- and output same direction						
Protection class			IP 64						
Elastomer coupling (recommended product type – validate sizing with cymex®)			ELC-0150BA032.000-X						
Bore diameter of coupling on the application side		mm	X = 019.000 - 036.000						
Mass moment of inertia (relates to the drive) Clamping hub diameter [mm]	H 28	J_1	kgcm ²	5.2	5.2	5.2	5.2	5.2	5.2
			10 ⁻³ in.lb.s ²	4.6	4.6	4.6	4.6	4.6	4.6

Please use our sizing software cymex® for a detailed sizing – www.wittenstein-cymex.com
Please consider the maximal tilting moment caused by the motor M_{1KMot} – see sizing

^{a)} Valid for torque transmission only

^{b)} Valid for standard clamping hub diameter

^{c)} Refers to center of the output shaft or flange

^{d)} Please reduce input speed at higher ambient temperatures

^{e)} Valid for: Smooth shaft

Motor shaft diameter [mm]

2-stage

up to 28⁴⁾ (H)⁵⁾
clamping hub diameter

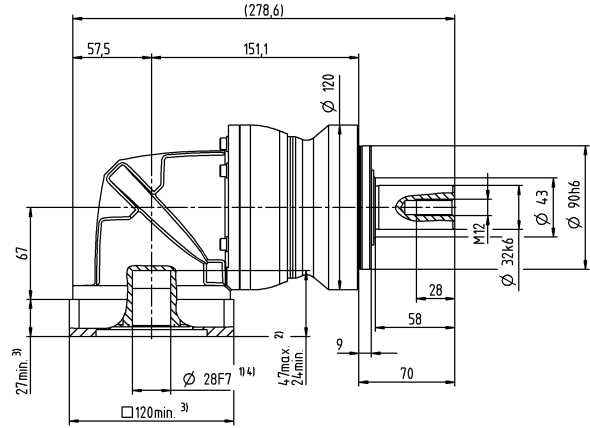
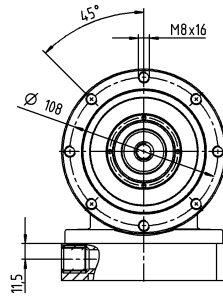

Other output variants

Shaft with key

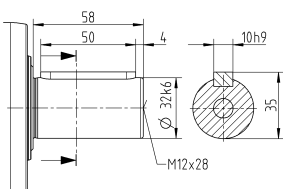

Splined shaft (DIN 5480)

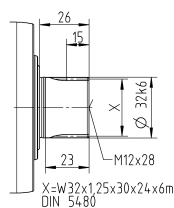

Non-tolerated dimensions are nominal dimensions

¹⁾ Check motor shaft fit

²⁾ Min. / Max. permissible motor shaft length

Longer motor shafts are possible, please contact alpha

³⁾ The dimensions depend on the motor

⁴⁾ Smaller motor shaft diameter is compensated

by a bushing with a minimum wall thickness of 1 mm

⁵⁾ Standard clamping hub diameter

NPLK 035 MF 3-stage

			3-stage														
Ratio	i		9	12	15	16	20	25	28	30	32	35	40	50	64	70	100
Max. torque ^{a) b) e)}	T_{2a}	Nm	180	240	300	320	400	400	408	320	408	400	408	400	352	400	352
		in.lb	1593	2124	2655	2832	3540	3540	3611	2832	3611	3540	3611	3540	3115	3540	3115
Max. acceleration torque ^{b)} (max. 1000 cycles per hour)	T_{2B}	Nm	105	141	176	188	235	250	255	200	255	250	255	250	220	250	220
		in.lb	929	1248	1558	1664	2080	2213	2257	1770	2257	2213	2257	2213	1947	2213	1947
Emergency stop torque ^{a) b) e)} (permitted 1000 times during the service life of the gearbox)	T_{2Not}	Nm	270	361	451	481	500	500	500	500	500	500	500	500	500	500	500
		in.lb	2390	3195	3992	4257	4425	4425	4425	4425	4425	4425	4425	4425	4425	4425	4425
Permitted average input speed ^{d)} (at T_{2a} and 20 °C ambient temperature)	n_{1N}	rpm	2700	3000	3000	3000	3000	3000	3000	3000	3000	3000	3000	3000	3000	3000	3000
Max. input speed	n_{1Max}	rpm	5000	5000	5000	5000	5000	5000	5000	5000	5000	5000	5000	5000	5000	5000	5000
Mean no load running torque ^{b)} (at $n_1=3000$ rpm and 20 °C gearbox temperature)	T_{012}	Nm	2.3	2.3	2.3	2.3	2.3	2.3	2.3	2.3	2.3	2.3	2.3	2.3	2.3	2.3	2.3
		in.lb	20	20	20	20	20	20	20	20	20	20	20	20	20	20	20
Max. backlash	j_t	arcmin	≤ 13														
Torsional rigidity ^{b)}	C_{t21}	Nm/arcmin	19	19	19	19	19	19	19	19	19	19	19	19	19	19	19
		in.lb/arcmin	168	168	168	168	168	168	168	168	168	168	168	168	168	168	168
Max. axial force ^{c)}	F_{2AMax}	N	5650														
		lb _f	1271														
Max. lateral force ^{c)}	F_{2OMax}	N	6600														
		lb _f	1485														
Max. tilting moment	M_{2KMax}	Nm	487														
		in.lb	4310														
Efficiency at full load	η	%	94														
Service life	L_h	h	> 20000														
Weight (incl. standard adapter plate)	m	kg	11														
		lb _m	24														
Operating noise (at reference ratio and reference speed – ratio-specific values available in cymex®)	L_{PA}	dB(A)	≤ 73														
Max. permitted housing temperature		°C	+90														
		°F	+194														
Ambient temperature		°C	0 to +40														
		°F	+32 to +104														
Lubrication			Lubricated for life														
Direction of rotation			In- and output same direction														
Protection class			IP 64														
Elastomer coupling (recommended product type – validate sizing with cymex®)			ELC-0150BA032.000-X														
Bore diameter of coupling on the application side		mm	X = 019.000 - 036.000														
Mass moment of inertia (relates to the drive) Clamping hub diameter [mm]	E	19	J_1	kgcm ²	1.7	1.7	1.7	1.7	1.7	1.7	1.7	1.7	1.7	1.7	1.7	1.7	1.7
				10 ⁻³ in.lb.s ²	1.5	1.5	1.5	1.5	1.5	1.5	1.5	1.5	1.5	1.5	1.5	1.5	1.5

Please use our sizing software cymex® for a detailed sizing – www.wittenstein-cymex.com
Please consider the maximal tilting moment caused by the motor M_{1KMot} – see sizing

- ^{a)} Valid for torque transmission only
- ^{b)} Valid for standard clamping hub diameter
- ^{c)} Refers to center of the output shaft or flange
- ^{d)} Please reduce input speed at higher ambient temperatures
- ^{e)} Valid for: Smooth shaft

Motor shaft diameter [mm]

3-stage

up to 19⁴⁾ (E)⁵⁾
clamping hub diameter

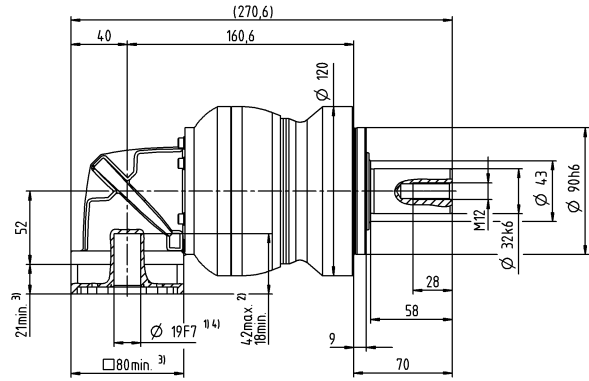
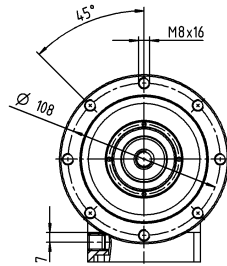

Other output variants

Shaft with key

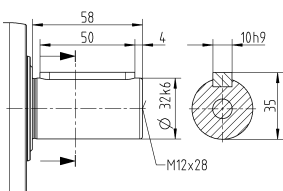

Splined shaft (DIN 5480)

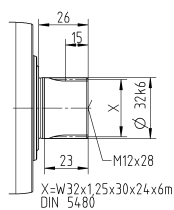

Non-tolerated dimensions are nominal dimensions

¹⁾ Check motor shaft fit

²⁾ Min. / Max. permissible motor shaft length

Longer motor shafts are possible, please contact alpha

³⁾ The dimensions depend on the motor

⁴⁾ Smaller motor shaft diameter is compensated

by a bushing with a minimum wall thickness of 1 mm

⁵⁾ Standard clamping hub diameter

NPLK 045 MF 3-stage

			3-stage					
Ratio	i		25	32	50	64	100	
Max. torque ^{a) b) e)}	T_{2a}	Nm	700	640	700	640	640	
		in.lb	6196	5665	6196	5665	5665	
Max. acceleration torque ^{e)} (max. 1000 cycles per hour)	T_{2B}	Nm	500	400	500	400	400	
		in.lb	4425	3540	4425	3540	3540	
Emergency stop torque ^{a) b) e)} (permitted 1000 times during the service life of the gearbox)	T_{2Not}	Nm	1000	1000	1000	1000	1000	
		in.lb	8851	8851	8851	8851	8851	
Permitted average input speed ^{d)} (at T_{2N} and 20 °C ambient temperature)	n_{1N}	rpm	2000	2000	2000	2000	2000	
Max. input speed	n_{1Max}	rpm	4500	4500	4500	4500	4500	
Mean no load running torque ^{b)} (at $n_1=3000$ rpm and 20 °C gearbox temperature)	T_{012}	Nm	4.7	4.7	4.7	4.7	4.7	
		in.lb	42	42	42	42	42	
Max. backlash	j_l	arcmin	≤ 11					
Torsional rigidity ^{b)}	C_{t21}	Nm/arcmin	54	54	54	54	54	
		in.lb/arcmin	478	478	478	478	478	
Max. axial force ^{c)}	F_{2AMax}	N	9870					
		lb _f	2221					
Max. lateral force ^{c)}	F_{2QMMax}	N	9900					
		lb _f	2228					
Max. tilting moment	M_{2KMMax}	Nm	952					
		in.lb	8426					
Efficiency at full load	η	%	94					
Service life	L_n	h	> 20000					
Weight (incl. standard adapter plate)	m	kg	22					
		lb _m	49					
Operating noise (at reference ratio and reference speed – ratio-specific values available in cymex®)	L_{PA}	dB(A)	≤ 74					
Max. permitted housing temperature		°C	+90					
		°F	+194					
Ambient temperature		°C	0 to +40					
		°F	+32 to +104					
Lubrication			Lubricated for life					
Direction of rotation			In- and output same direction					
Protection class			IP 64					
Elastomer coupling (recommended product type – validate sizing with cymex®)			ELC-0300BA040.000-X					
Bore diameter of coupling on the application side		mm	X = 020.000 - 045.000					
Mass moment of inertia (relates to the drive) Clamping hub diameter [mm]	H 28	J_1	kgcm ²	6.7	6.7	6.7	6.7	6.7
			10 ⁻³ in.lb.s ²	5.9	5.9	5.9	5.9	5.9

Please use our sizing software cymex® for a detailed sizing – www.wittenstein-cymex.com
Please consider the maximal tilting moment caused by the motor M_{1KMot} – see sizing

^{a)} Valid for torque transmission only

^{b)} Valid for standard clamping hub diameter

^{c)} Refers to center of the output shaft or flange

^{d)} Please reduce input speed at higher ambient temperatures

^{e)} Valid for: Smooth shaft

Motor shaft diameter [mm]

3-stage

up to 28⁴⁾ (H)⁵⁾
clamping hub
diameter

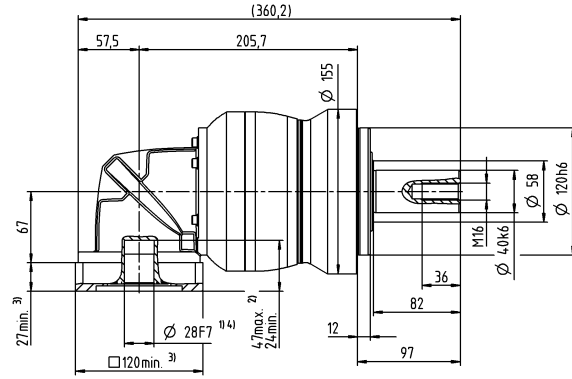
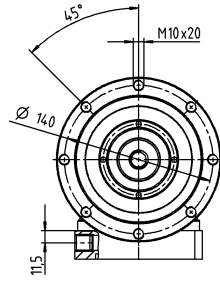

Other output variants

Shaft with key

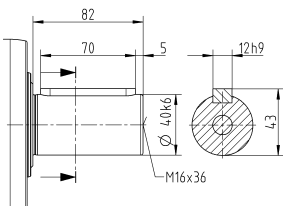

Splined shaft (DIN 5480)

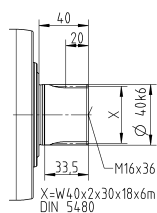

Non-tolerated dimensions are nominal dimensions

¹⁾ Check motor shaft fit

²⁾ Min. / Max. permissible motor shaft length

Longer motor shafts are possible, please contact alpha

³⁾ The dimensions depend on the motor

⁴⁾ Smaller motor shaft diameter is compensated by a bushing with a minimum wall thickness of 1 mm

⁵⁾ Standard clamping hub diameter

NPSK 015 MF 2-stage

			2-stage							
Ratio	i		3	4	5	7	8	10		
Max. torque ^{a) b) e)}	T_{2a}	Nm	33	44	55	64	56	56		
		in.lb	292	389	487	566	496	496		
Max. acceleration torque ^{b)} (max. 1000 cycles per hour)	T_{2B}	Nm	16	21	27	37	35	35		
		in.lb	142	186	239	327	310	310		
Emergency stop torque ^{a) b) e)} (permitted 1000 times during the service life of the gearbox)	T_{2Not}	Nm	41	55	69	80	80	80		
		in.lb	363	487	611	708	708	708		
Permitted average input speed ^{d)} (at T_{2a} and 20 °C ambient temperature)	n_{1N}	rpm	2900	3100	3300	3300	3300	3300		
Max. input speed	n_{1Max}	rpm	5000	5000	5000	5000	5000	5000		
Mean no load running torque ^{b)} (at $n_1=3000$ rpm and 20 °C gearbox temperature)	T_{012}	Nm	1.2	1.2	1.2	1.2	1.2	1.2		
		in.lb	11	11	11	11	11	11		
Max. backlash	j_t	arcmin	≤ 15							
Torsional rigidity ^{b)}	C_{t21}	Nm/arcmin	2.4	2.4	2.4	2.4	2.4	2.4		
		in.lb/arcmin	21	21	21	21	21	21		
Max. axial force ^{c)}	F_{2AMax}	N	2400							
		lb _f	540							
Max. lateral force ^{c)}	F_{2OMax}	N	2800							
		lb _f	630							
Max. tilting moment	M_{2KMMax}	Nm	152							
		in.lb	1345							
Efficiency at full load	η	%	95							
Service life	L_h	h	> 20000							
Weight (incl. standard adapter plate)	m	kg	2.2							
		lb _m	4.9							
Operating noise (at reference ratio and reference speed – ratio-specific values available in cymex®)	L_{PA}	dB(A)	≤ 70							
Max. permitted housing temperature		°C	+90							
		°F	+194							
Ambient temperature		°C	0 to +40							
		°F	+32 to +104							
Lubrication			Lubricated for life							
Direction of rotation			In- and output same direction							
Protection class			IP 64							
Elastomer coupling (recommended product type – validate sizing with cymex®)			ELC-0060BA016.000-X							
Bore diameter of coupling on the application side		mm	X = 012.000 - 032.000							
Mass moment of inertia (relates to the drive) Clamping hub diameter [mm]	C	14	J_1	kgcm ²	0.32	0.32	0.32	0.32	0.32	0.32
				10 ⁻³ in.lb.s ²	0.28	0.28	0.28	0.28	0.28	0.28

Please use our sizing software cymex® for a detailed sizing – www.wittenstein-cymex.com
Please consider the maximal tilting moment caused by the motor M_{1KMot} – see sizing

^{a)} Valid for torque transmission only

^{b)} Valid for standard clamping hub diameter

^{c)} Refers to center of the output shaft or flange

^{d)} Please reduce input speed at higher ambient temperatures

^{e)} Valid for: Smooth shaft

Motor shaft diameter [mm]

2-stage

up to 14⁴⁾ (C)⁵⁾
clamping hub
diameter

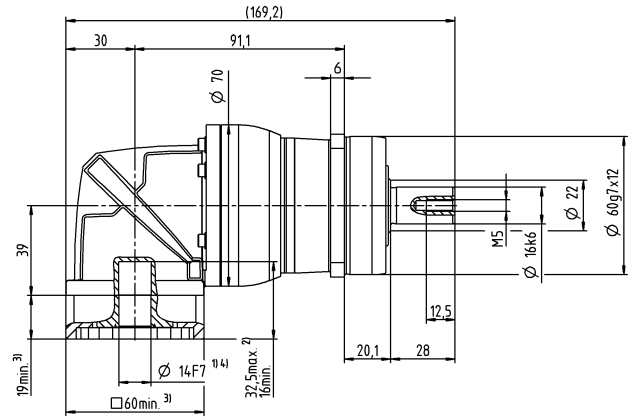
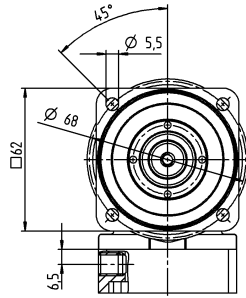

Other output variants

Shaft with key

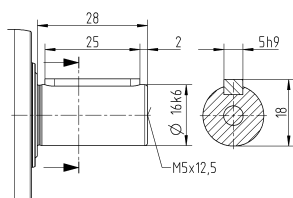

Splined shaft (DIN 5480)

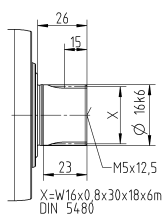

Non-tolerated dimensions are nominal dimensions

¹⁾ Check motor shaft fit

²⁾ Min. / Max. permissible motor shaft length

Longer motor shafts are possible, please contact alpha

³⁾ The dimensions depend on the motor

⁴⁾ Smaller motor shaft diameter is compensated

by a bushing with a minimum wall thickness of 1 mm

⁵⁾ Standard clamping hub diameter

NPSK 015 MF 3-stage

			3-stage													
Ratio	i		12	15	16	20	25	28	30	32	35	40	50	64	70	100
Max. torque ^{a) b) e)}	T_{2a}	Nm	42	51	56	56	64	56	51	56	64	56	64	56	64	56
		in.lb	372	451	496	496	566	496	451	496	566	496	566	496	566	496
Max. acceleration torque ^{b)} (max. 1000 cycles per hour)	T_{2B}	Nm	20	25	27	34	40	35	31	35	40	35	40	35	40	35
		in.lb	177	221	239	301	354	310	274	310	354	310	354	310	354	310
Emergency stop torque ^{a) b) e)} (permitted 1000 times during the service life of the gearbox)	T_{2Not}	Nm	52	65	70	80	80	80	80	80	80	80	80	80	80	80
		in.lb	460	575	620	708	708	708	708	708	708	708	708	708	708	708
Permitted average input speed ^{d)} (at T_{2a} and 20 °C ambient temperature)	n_{1N}	rpm	3800	3800	3800	3800	3800	3800	3800	3800	3800	3800	3800	3800	3800	3800
Max. input speed	n_{1Max}	rpm	5000	5000	5000	5000	5000	5000	5000	5000	5000	5000	5000	5000	5000	5000
Mean no load running torque ^{b)} (at $n_1 = 3000$ rpm and 20 °C gearbox temperature)	T_{012}	Nm	0.52	0.52	0.52	0.52	0.52	0.52	0.52	0.52	0.52	0.52	0.52	0.52	0.52	0.52
		in.lb	4.6	4.6	4.6	4.6	4.6	4.6	4.6	4.6	4.6	4.6	4.6	4.6	4.6	4.6
Max. backlash	j_t	arcmin	≤ 12													
Torsional rigidity ^{b)}	C_{t21}	Nm/arcmin	3	3	3	3	3	3	3	3	3	3	3	3	3	3
		in.lb/arcmin	27	27	27	27	27	27	27	27	27	27	27	27	27	27
Max. axial force ^{c)}	F_{2AMax}	N	2400													
		lb _f	540													
Max. lateral force ^{c)}	F_{2OMax}	N	2800													
		lb _f	630													
Max. tilting moment	M_{2KMMax}	Nm	152													
		in.lb	1345													
Efficiency at full load	η	%	94													
Service life	L_h	h	> 20000													
Weight (incl. standard adapter plate)	m	kg	2.3													
		lb _m	5.1													
Operating noise (at reference ratio and reference speed – ratio-specific values available in cymex®)	L_{PA}	dB(A)	≤ 68													
Max. permitted housing temperature		°C	+90													
		°F	+194													
Ambient temperature		°C	0 to +40													
		°F	+32 to +104													
Lubrication			Lubricated for life													
Direction of rotation			In- and output same direction													
Protection class			IP 64													
Elastomer coupling (recommended product type – validate sizing with cymex®)			ELC-0060BA016.000-X													
Bore diameter of coupling on the application side		mm	X = 012.000 - 032.000													
Mass moment of inertia (relates to the drive) Clamping hub diameter [mm]	B	11	J_1	kgcm ²	0.14	0.14	0.14	0.14	0.14	0.14	0.14	0.14	0.14	0.14	0.14	0.14
				10 ⁻³ in.lb.s ²	0.12	0.12	0.12	0.12	0.12	0.12	0.12	0.12	0.12	0.12	0.12	0.12

Please use our sizing software cymex® for a detailed sizing – www.wittenstein-cymex.com
Please consider the maximal tilting moment caused by the motor M_{1KMot} – see sizing

^{a)} Valid for torque transmission only

^{b)} Valid for standard clamping hub diameter

^{c)} Refers to center of the output shaft or flange

^{d)} Please reduce input speed at higher ambient temperatures

^{e)} Valid for: Smooth shaft

Motor shaft diameter [mm]

3-stage

up to 11⁴⁾ (B)⁵⁾
clamping hub diameter

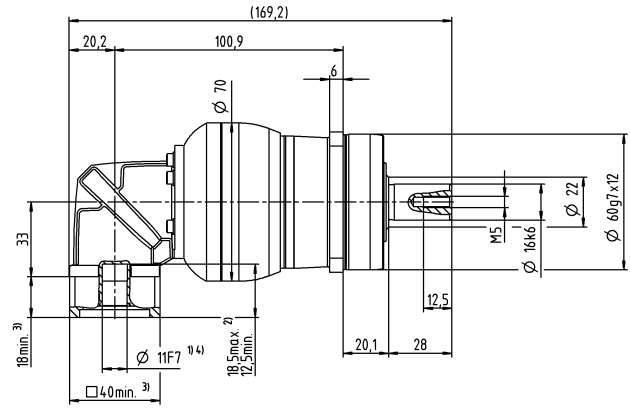
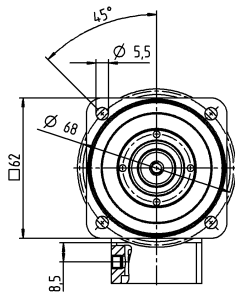

Other output variants

Shaft with key

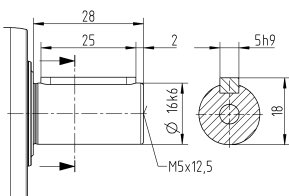

Splined shaft (DIN 5480)

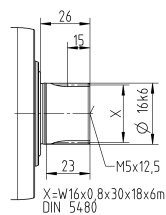

Non-tolerated dimensions are nominal dimensions

¹⁾ Check motor shaft fit

²⁾ Min. / Max. permissible motor shaft length

Longer motor shafts are possible, please contact alpha

³⁾ The dimensions depend on the motor

⁴⁾ Smaller motor shaft diameter is compensated

by a bushing with a minimum wall thickness of 1 mm

⁵⁾ Standard clamping hub diameter

NPSK 025 MF 2-stage

			2-stage						
Ratio	i		3	4	5	7	8	10	
Max. torque ^{a) b) e)}	T_{2a}	Nm	60	80	100	140	144	144	
		in.lb	531	708	885	1239	1275	1275	
Max. acceleration torque ^{b)} (max. 1000 cycles per hour)	T_{2B}	Nm	35	47	58	82	90	90	
		in.lb	310	416	513	726	797	797	
Emergency stop torque ^{a) b) e)} (permitted 1000 times during the service life of the gearbox)	T_{2Not}	Nm	90	120	150	190	190	190	
		in.lb	797	1062	1328	1682	1682	1682	
Permitted average input speed ^{d)} (at T_{2a} and 20 °C ambient temperature)	n_{1N}	rpm	2700	2900	3000	3000	3000	3000	
Max. input speed	n_{1Max}	rpm	5000	5000	5000	5000	5000	5000	
Mean no load running torque ^{b)} (at $n_1=3000$ rpm and 20 °C gearbox temperature)	T_{012}	Nm	2.4	2.4	2.4	2.4	2.4	2.4	
		in.lb	21	21	21	21	21	21	
Max. backlash	j_t	arcmin	≤ 15						
Torsional rigidity ^{b)}	C_{t21}	Nm/arcmin	6.2	6.2	6.2	6.2	6.2	6.2	
		in.lb/arcmin	55	55	55	55	55	55	
Max. axial force ^{c)}	F_{2AMax}	N	3350						
		lb _f	754						
Max. lateral force ^{c)}	F_{2OMax}	N	4200						
		lb _f	945						
Max. tilting moment	M_{2KMMax}	Nm	236						
		in.lb	2089						
Efficiency at full load	η	%	95						
Service life	L_h	h	> 20000						
Weight (incl. standard adapter plate)	m	kg	4.7						
		lb _m	10						
Operating noise (at reference ratio and reference speed – ratio-specific values available in cymex®)	L_{PA}	dB(A)	≤ 73						
Max. permitted housing temperature		°C	+90						
		°F	+194						
Ambient temperature		°C	0 to +40						
		°F	+32 to +104						
Lubrication			Lubricated for life						
Direction of rotation			In- and output same direction						
Protection class			IP 64						
Elastomer coupling (recommended product type – validate sizing with cymex®)			ELC-0060BA022.000-X						
Bore diameter of coupling on the application side		mm	X = 012.000 - 032.000						
Mass moment of inertia (relates to the drive) Clamping hub diameter [mm]	E 19	J_1	kgcm ²	1.2	1.2	1.2	1.2	1.2	1.2
			10 ⁻³ in.lb.s ²	1.1	1.1	1.1	1.1	1.1	1.1

Please use our sizing software cymex® for a detailed sizing – www.wittenstein-cymex.com
Please consider the maximal tilting moment caused by the motor M_{1KMot} – see sizing

^{a)} Valid for torque transmission only

^{b)} Valid for standard clamping hub diameter

^{c)} Refers to center of the output shaft or flange

^{d)} Please reduce input speed at higher ambient temperatures

^{e)} Valid for: Smooth shaft

Motor shaft diameter [mm]

2-stage

up to 19⁴⁾ (E)⁵⁾
clamping hub diameter

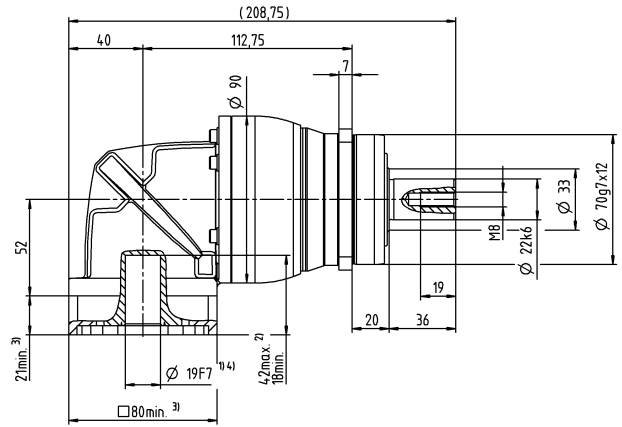
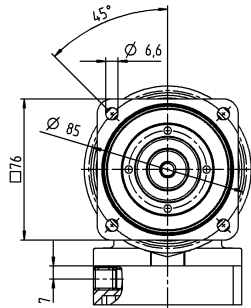

Other output variants

Shaft with key

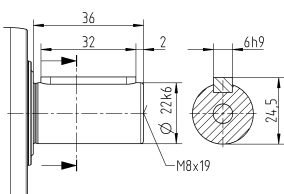

Splined shaft (DIN 5480)

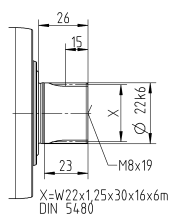

Non-tolerated dimensions are nominal dimensions

¹⁾ Check motor shaft fit

²⁾ Min. / Max. permissible motor shaft length

Longer motor shafts are possible, please contact alpha

³⁾ The dimensions depend on the motor

⁴⁾ Smaller motor shaft diameter is compensated by a bushing with a minimum wall thickness of 1 mm

⁵⁾ Standard clamping hub diameter

NPSK 025 MF 3-stage

			3-stage														
Ratio	i		9	12	15	16	20	25	28	30	32	35	40	50	64	70	100
Max. torque ^{a) b) e)}	T_{2a}	Nm	99	128	128	152	152	160	152	128	152	160	152	160	144	160	144
		in.lb	876	1133	1133	1345	1345	1416	1345	1133	1345	1416	1345	1416	1275	1416	1275
Max. acceleration torque ^{b)} (max. 1000 cycles per hour)	T_{2B}	Nm	48	65	80	86	95	100	95	80	95	100	95	100	90	100	90
		in.lb	425	575	708	761	841	885	841	708	841	885	841	885	797	885	797
Emergency stop torque ^{a) b) e)} (permitted 1000 times during the service life of the gearbox)	T_{2Not}	Nm	124	166	190	190	190	190	190	190	190	190	190	190	190	190	190
		in.lb	1097	1469	1682	1682	1682	1682	1682	1682	1682	1682	1682	1682	1682	1682	1682
Permitted average input speed ^{d)} (at T_{2a} and 20 °C ambient temperature)	n_{1N}	rpm	2900	3300	3300	3300	3300	3300	3300	3300	3300	3300	3300	3300	3300	3300	3300
Max. input speed	n_{1Max}	rpm	5000	5000	5000	5000	5000	5000	5000	5000	5000	5000	5000	5000	5000	5000	5000
Mean no load running torque ^{b)} (at $n_1=3000$ rpm and 20 °C gearbox temperature)	T_{012}	Nm	0.97	0.97	0.97	0.97	0.97	0.97	0.97	0.97	0.97	0.97	0.97	0.97	0.97	0.97	0.97
		in.lb	8.6	8.6	8.6	8.6	8.6	8.6	8.6	8.6	8.6	8.6	8.6	8.6	8.6	8.6	8.6
Max. backlash	j_t	arcmin	≤ 13														
Torsional rigidity ^{b)}	C_{121}	Nm/arcmin	8.4	8.4	8.4	8.4	8.4	8.4	8.4	8.4	8.4	8.4	8.4	8.4	8.4	8.4	8.4
		in.lb/arcmin	74	74	74	74	74	74	74	74	74	74	74	74	74	74	74
Max. axial force ^{c)}	F_{2AMax}	N	3350														
		lb _f	754														
Max. lateral force ^{c)}	F_{2OMax}	N	4200														
		lb _f	945														
Max. tilting moment	M_{2KMMax}	Nm	236														
		in.lb	2089														
Efficiency at full load	η	%	94														
Service life	L_h	h	> 20000														
Weight (incl. standard adapter plate)	m	kg	4.3														
		lb _m	9.5														
Operating noise (at reference ratio and reference speed – ratio-specific values available in cymex®)	L_{PA}	dB(A)	≤ 70														
Max. permitted housing temperature		°C	+90														
		°F	+194														
Ambient temperature		°C	0 to +40														
		°F	+32 to +104														
Lubrication			Lubricated for life														
Direction of rotation			In- and output same direction														
Protection class			IP 64														
Elastomer coupling (recommended product type – validate sizing with cymex®)			ELC-0060BA022.000-X														
Bore diameter of coupling on the application side		mm	X = 012.000 - 032.000														
Mass moment of inertia (relates to the drive) Clamping hub diameter [mm]	C	14	J_1	kgcm ²	0.45	0.45	0.45	0.45	0.45	0.45	0.45	0.45	0.45	0.45	0.45	0.45	0.45
				10 ⁻³ in.lb.s ²	0.4	0.4	0.4	0.4	0.4	0.4	0.4	0.4	0.4	0.4	0.4	0.4	0.4

Please use our sizing software cymex® for a detailed sizing – www.wittenstein-cymex.com
Please consider the maximal tilting moment caused by the motor M_{1KMot} – see sizing

^{a)} Valid for torque transmission only

^{b)} Valid for standard clamping hub diameter

^{c)} Refers to center of the output shaft or flange

^{d)} Please reduce input speed at higher ambient temperatures

^{e)} Valid for: Smooth shaft

Motor shaft diameter [mm]

3-stage

up to 14⁴⁾ (C)⁵⁾
clamping hub
diameter

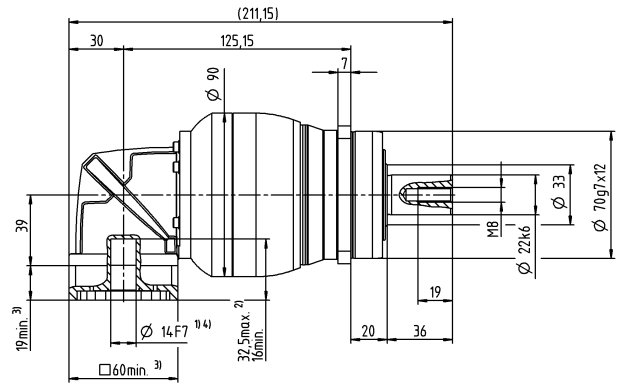
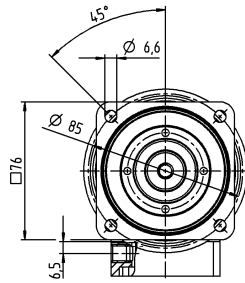

Other output variants

Shaft with key

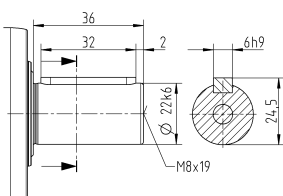

Splined shaft (DIN 5480)

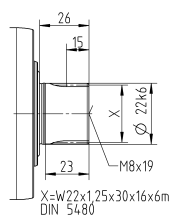

Non-tolerated dimensions are nominal dimensions

¹⁾ Check motor shaft fit

²⁾ Min. / Max. permissible motor shaft length

Longer motor shafts are possible, please contact alpha

³⁾ The dimensions depend on the motor

⁴⁾ Smaller motor shaft diameter is compensated

by a bushing with a minimum wall thickness of 1 mm

⁵⁾ Standard clamping hub diameter

NPSK 035 MF 2-stage

			2-stage						
Ratio	i		3	4	5	7	8	10	
Max. torque ^{a) b) e)}	T_{2a}	Nm	150	200	250	350	352	352	
		in.lb	1328	1770	2213	3098	3115	3115	
Max. acceleration torque ^{b)} (max. 1000 cycles per hour)	T_{2B}	Nm	93	124	155	217	220	220	
		in.lb	823	1097	1372	1921	1947	1947	
Emergency stop torque ^{a) b) e)} (permitted 1000 times during the service life of the gearbox)	T_{2Not}	Nm	238	318	397	500	500	500	
		in.lb	2106	2815	3514	4425	4425	4425	
Permitted average input speed ^{d)} (at T_{2a} and 20 °C ambient temperature)	n_{1N}	rpm	2000	2000	2000	2000	2000	2000	
Max. input speed	n_{1Max}	rpm	4500	4500	4500	4500	4500	4500	
Mean no load running torque ^{b)} (at $n_1=3000$ rpm and 20 °C gearbox temperature)	T_{012}	Nm	5.8	5.8	5.8	5.8	5.8	5.8	
		in.lb	51	51	51	51	51	51	
Max. backlash	j_t	arcmin	≤ 13						
Torsional rigidity ^{b)}	C_{t21}	Nm/arcmin	16	16	16	16	16	16	
		in.lb/arcmin	142	142	142	142	142	142	
Max. axial force ^{c)}	F_{2AMax}	N	5650						
		lb _f	1271						
Max. lateral force ^{c)}	F_{2OMax}	N	6600						
		lb _f	1485						
Max. tilting moment	M_{2KMMax}	Nm	487						
		in.lb	4310						
Efficiency at full load	η	%	95						
Service life	L_h	h	> 20000						
Weight (incl. standard adapter plate)	m	kg	10						
		lb _m	22						
Operating noise (at reference ratio and reference speed – ratio-specific values available in cymex®)	L_{PA}	dB(A)	≤ 74						
Max. permitted housing temperature		°C	+90						
		°F	+194						
Ambient temperature		°C	0 to +40						
		°F	+32 to +104						
Lubrication			Lubricated for life						
Direction of rotation			In- and output same direction						
Protection class			IP 64						
Elastomer coupling (recommended product type – validate sizing with cymex®)			ELC-0150BA032.000-X						
Bore diameter of coupling on the application side		mm	X = 019.000 - 036.000						
Mass moment of inertia (relates to the drive) Clamping hub diameter [mm]	H 28	J_1	kgcm ²	5.2	5.2	5.2	5.2	5.2	5.2
			10 ⁻³ in.lb.s ²	4.6	4.6	4.6	4.6	4.6	4.6

Please use our sizing software cymex® for a detailed sizing – www.wittenstein-cymex.com
Please consider the maximal tilting moment caused by the motor M_{1KMot} – see sizing

^{a)} Valid for torque transmission only

^{b)} Valid for standard clamping hub diameter

^{c)} Refers to center of the output shaft or flange

^{d)} Please reduce input speed at higher ambient temperatures

^{e)} Valid for: Smooth shaft

Motor shaft diameter [mm]

2-stage

up to 28⁴⁾ (H)⁵⁾
clamping hub diameter

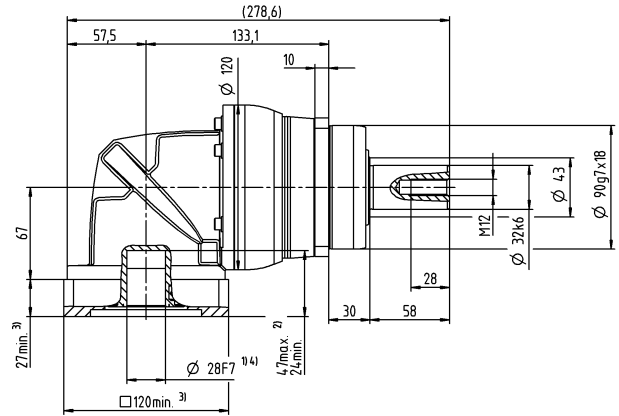
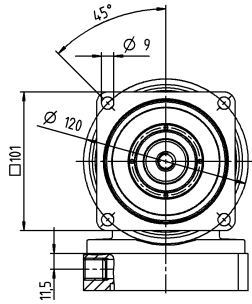

Other output variants

Shaft with key

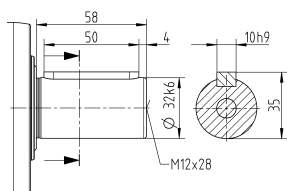

Splined shaft (DIN 5480)

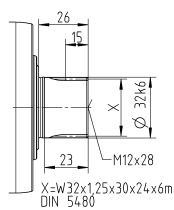

Non-tolerated dimensions are nominal dimensions

¹⁾ Check motor shaft fit

²⁾ Min. / Max. permissible motor shaft length

Longer motor shafts are possible, please contact alpha

³⁾ The dimensions depend on the motor

⁴⁾ Smaller motor shaft diameter is compensated

by a bushing with a minimum wall thickness of 1 mm

⁵⁾ Standard clamping hub diameter

NPSK 035 MF 3-stage

			3-stage														
Ratio	i		9	12	15	16	20	25	28	30	32	35	40	50	64	70	100
Max. torque ^{a) b) e)}	T_{2a}	Nm	180	240	300	320	400	400	408	320	408	400	408	400	352	400	352
		in.lb	1593	2124	2655	2832	3540	3540	3611	2832	3611	3540	3611	3540	3115	3540	3115
Max. acceleration torque ^{b)} (max. 1000 cycles per hour)	T_{2B}	Nm	105	141	176	188	235	250	255	200	255	250	255	250	220	250	220
		in.lb	929	1248	1558	1664	2080	2213	2257	1770	2257	2213	2257	2213	1947	2213	1947
Emergency stop torque ^{a) b) e)} (permitted 1000 times during the service life of the gearbox)	T_{2Not}	Nm	270	361	451	481	500	500	500	500	500	500	500	500	500	500	500
		in.lb	2390	3195	3992	4257	4425	4425	4425	4425	4425	4425	4425	4425	4425	4425	4425
Permitted average input speed ^{d)} (at T_{2a} and 20 °C ambient temperature)	n_{1N}	rpm	2700	3000	3000	3000	3000	3000	3000	3000	3000	3000	3000	3000	3000	3000	3000
Max. input speed	n_{1Max}	rpm	5000	5000	5000	5000	5000	5000	5000	5000	5000	5000	5000	5000	5000	5000	5000
Mean no load running torque ^{b)} (at $n_1=3000$ rpm and 20 °C gearbox temperature)	T_{012}	Nm	2.3	2.3	2.3	2.3	2.3	2.3	2.3	2.3	2.3	2.3	2.3	2.3	2.3	2.3	2.3
		in.lb	20	20	20	20	20	20	20	20	20	20	20	20	20	20	20
Max. backlash	j_t	arcmin	≤ 13														
Torsional rigidity ^{b)}	C_{21}	Nm/arcmin	19	19	19	19	19	19	19	19	19	19	19	19	19	19	19
		in.lb/arcmin	168	168	168	168	168	168	168	168	168	168	168	168	168	168	168
Max. axial force ^{c)}	F_{2AMax}	N	5650														
		lb _f	1271														
Max. lateral force ^{c)}	F_{2OMax}	N	6600														
		lb _f	1485														
Max. tilting moment	M_{2KMax}	Nm	487														
		in.lb	4310														
Efficiency at full load	η	%	94														
Service life	L_h	h	> 20000														
Weight (incl. standard adapter plate)	m	kg	10														
		lb _m	22														
Operating noise (at reference ratio and reference speed – ratio-specific values available in cymex®)	L_{PA}	dB(A)	≤ 73														
Max. permitted housing temperature		°C	+90														
		°F	+194														
Ambient temperature		°C	0 to +40														
		°F	+32 to +104														
Lubrication			Lubricated for life														
Direction of rotation			In- and output same direction														
Protection class			IP 64														
Elastomer coupling (recommended product type – validate sizing with cymex®)			ELC-0150BA032.000-X														
Bore diameter of coupling on the application side		mm	X = 019.000 - 036.000														
Mass moment of inertia (relates to the drive) Clamping hub diameter [mm]	E	19	J_1	kgcm ²	1.7	1.7	1.7	1.7	1.7	1.7	1.7	1.7	1.7	1.7	1.7	1.7	1.7
				10 ⁻³ in.lb.s ²	1.5	1.5	1.5	1.5	1.5	1.5	1.5	1.5	1.5	1.5	1.5	1.5	1.5

Please use our sizing software cymex® for a detailed sizing – www.wittenstein-cymex.com
Please consider the maximal tilting moment caused by the motor M_{1KMot} – see sizing

^{a)} Valid for torque transmission only

^{b)} Valid for standard clamping hub diameter

^{c)} Refers to center of the output shaft or flange

^{d)} Please reduce input speed at higher ambient temperatures

^{e)} Valid for: Smooth shaft

Motor shaft diameter [mm]

3-stage

up to 19⁴⁾ (E)⁵⁾
clamping hub diameter

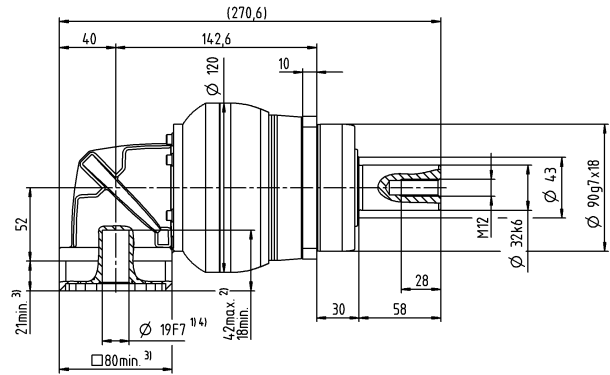
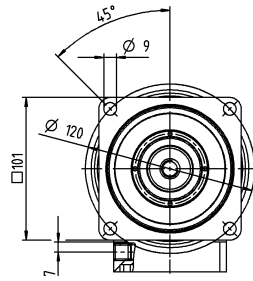

Other output variants

Shaft with key

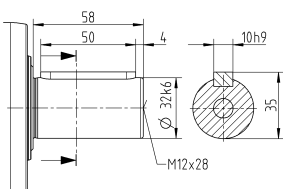

Splined shaft (DIN 5480)

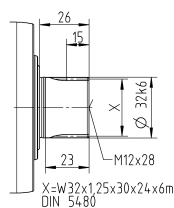

Non-tolerated dimensions are nominal dimensions

¹⁾ Check motor shaft fit

²⁾ Min. / Max. permissible motor shaft length

Longer motor shafts are possible, please contact alpha

³⁾ The dimensions depend on the motor

⁴⁾ Smaller motor shaft diameter is compensated by a bushing with a minimum wall thickness of 1 mm

⁵⁾ Standard clamping hub diameter

NPSK 045 MF 3-stage

			3-stage					
Ratio	i		25	32	50	64	100	
Max. torque ^{a) b) e)}	T_{2a}	Nm	700	640	700	640	640	
		in.lb	6196	5665	6196	5665	5665	
Max. acceleration torque ^{e)} (max. 1000 cycles per hour)	T_{2B}	Nm	500	400	500	400	400	
		in.lb	4425	3540	4425	3540	3540	
Emergency stop torque ^{a) b) e)} (permitted 1000 times during the service life of the gearbox)	T_{2Not}	Nm	1000	1000	1000	1000	1000	
		in.lb	8851	8851	8851	8851	8851	
Permitted average input speed ^{d)} (at T_{2N} and 20 °C ambient temperature)	n_{1N}	rpm	2000	2000	2000	2000	2000	
Max. input speed	n_{1Max}	rpm	4500	4500	4500	4500	4500	
Mean no load running torque ^{b)} (at $n_1=3000$ rpm and 20 °C gearbox temperature)	T_{012}	Nm	4.7	4.7	4.7	4.7	4.7	
		in.lb	42	42	42	42	42	
Max. backlash	j_l	arcmin	≤ 11					
Torsional rigidity ^{b)}	C_{121}	Nm/arcmin	54	54	54	54	54	
		in.lb/arcmin	478	478	478	478	478	
Max. axial force ^{c)}	F_{2AMax}	N	9870					
		lb _f	2221					
Max. lateral force ^{c)}	F_{2QMMax}	N	9900					
		lb _f	2228					
Max. tilting moment	M_{2KMMax}	Nm	952					
		in.lb	8426					
Efficiency at full load	η	%	94					
Service life	L_n	h	> 20000					
Weight (incl. standard adapter plate)	m	kg	21					
		lb _m	46					
Operating noise (at reference ratio and reference speed – ratio-specific values available in cymex®)	L_{PA}	dB(A)	≤ 74					
Max. permitted housing temperature		°C	+90					
		°F	+194					
Ambient temperature		°C	0 to +40					
		°F	+32 to +104					
Lubrication			Lubricated for life					
Direction of rotation			In- and output same direction					
Protection class			IP 64					
Elastomer coupling (recommended product type – validate sizing with cymex®)			ELC-0300BA040.000-X					
Bore diameter of coupling on the application side		mm	X = 020.000 - 045.000					
Mass moment of inertia (relates to the drive) Clamping hub diameter [mm]	H 28	J_1	kgcm ²	6.7	6.7	6.7	6.7	6.7
			10 ⁻³ in.lb.s ²	5.9	5.9	5.9	5.9	5.9

Please use our sizing software cymex® for a detailed sizing – www.wittenstein-cymex.com
Please consider the maximal tilting moment caused by the motor M_{1KMot} – see sizing

^{a)} Valid for torque transmission only

^{b)} Valid for standard clamping hub diameter

^{c)} Refers to center of the output shaft or flange

^{d)} Please reduce input speed at higher ambient temperatures

^{e)} Valid for: Smooth shaft

Motor shaft diameter [mm]

3-stage

up to 28⁴⁾ (H)⁵⁾
clamping hub
diameter

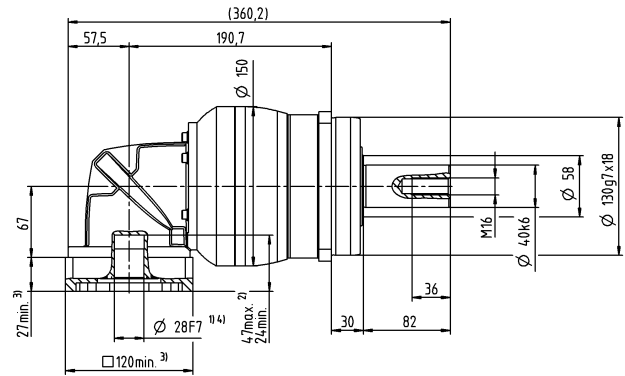
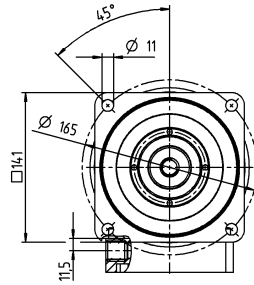

Other output variants

Shaft with key

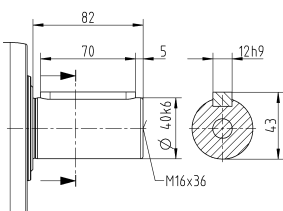

Splined shaft (DIN 5480)

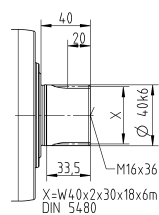

Non-tolerated dimensions are nominal dimensions

¹⁾ Check motor shaft fit

²⁾ Min. / Max. permissible motor shaft length

Longer motor shafts are possible, please contact alpha

³⁾ The dimensions depend on the motor

⁴⁾ Smaller motor shaft diameter is compensated by a bushing with a minimum wall thickness of 1 mm

⁵⁾ Standard clamping hub diameter

NPTK 005 MF 2- / 3-stage

			2-stage					3-stage									
Ratio	i		4	5	7	8	10	16	20	25	28	35	40	50	64	70	100
Max. torque ^{a) b)}	T_{2a}	Nm	14	17	22	21	21	18	18	22	18	22	18	22	21	22	21
		in.lb	124	150	195	186	186	159	159	195	159	195	159	195	186	195	186
Max. acceleration torque (max. 1000 cycles per hour)	T_{2B}	Nm	6.8	8.5	12	13	13	11	11	13	11	13	11	13	13	13	13
		in.lb	60	75	106	115	115	97	97	115	97	115	97	115	115	115	115
Emergency stop torque ^{a) b)} (permitted 1000 times during the service life of the gearbox)	T_{2Not}	Nm	17	21	26	26	26	26	26	26	26	26	26	26	26	26	26
		in.lb	150	186	230	230	230	230	230	230	230	230	230	230	230	230	230
Permitted average input speed ^{d)} (at T_{2N} and 20 °C ambient temperature)	n_{1N}	rpm	3800	3800	3800	3800	3800	3800	3800	3800	3800	3800	3800	3800	3800	3800	3800
Max. input speed	n_{1Max}	rpm	5000	5000	5000	5000	5000	5000	5000	5000	5000	5000	5000	5000	5000	5000	5000
Mean no load running torque ^{b)} (at $n_1=3000$ rpm and 20 °C gearbox temperature)	T_{012}	Nm	0.26	0.26	0.26	0.26	0.26	0.22	0.22	0.22	0.22	0.22	0.22	0.22	0.22	0.22	0.22
		in.lb	2.3	2.3	2.3	2.3	2.3	1.9	1.9	1.9	1.9	1.9	1.9	1.9	1.9	1.9	1.9
Max. backlash	j_i	arcmin	≤ 15					≤ 15									
Torsional rigidity ^{b)}	C_{i21}	Nm/arcmin	0.9	0.9	0.9	0.9	0.9	1.2	1.2	1.2	1.2	1.2	1.2	1.2	1.2	1.2	1.2
		in.lb/arcmin	8	8	8	8	8	11	11	11	11	11	11	11	11	11	11
Max. axial force ^{c)}	F_{2AMax}	N	600					600									
		lb _f	135					135									
Max. tilting moment	M_{2KMax}	Nm	17					17									
		in.lb	150					150									
Efficiency at full load	η	%	95					94									
Service life	L_h	h	> 20000					> 20000									
Weight (incl. standard adapter plate)	m	kg	1.3					1.7									
		lb _m	2.9					3.8									
Operating noise (at reference ratio and reference speed – ratio-specific values available in cymex®)	L_{pA}	dB(A)	≤ 68					≤ 68									
Max. permitted housing temperature		°C	+90					+90									
		°F	+194					+194									
Ambient temperature		°C	0 to +40					0 to +40									
		°F	+32 to +104					+32 to +104									
Lubrication			Lubricated for life														
Direction of rotation			In- and output same direction														
Protection class			IP 64														
Elastomer coupling (recommended product type – validate sizing with cymex®)			ELT-00020BAX-025.00														
Bore diameter of coupling on the application side		mm	X = 008.000 - 025.000														
Mass moment of inertia (relates to the drive) Clamping hub diameter [mm]	B	11	J_1	kgcm ²	0.11	0.11	0.11	0.11	0.11	0.11	0.11	0.11	0.11	0.11	0.11	0.11	0.11
				10 ⁻³ in.lb.s ²	0.1	0.1	0.1	0.1	0.1	0.1	0.1	0.1	0.1	0.1	0.1	0.1	0.1

Please use our sizing software cymex® for a detailed sizing – www.wittenstein-cymex.com
Please consider the maximal tilting moment caused by the motor M_{1KMot} – see sizing

^{a)} Valid for torque transmission only

^{b)} Valid for standard clamping hub diameter

^{c)} Refers to center of the output shaft or flange

^{d)} Please reduce input speed at higher ambient temperatures

2-stage

up to 11⁴⁾ (B)⁵⁾
clamping hub
diameter

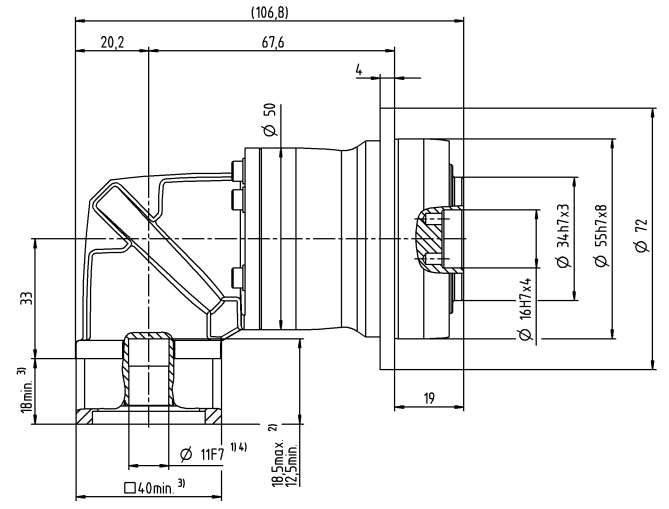
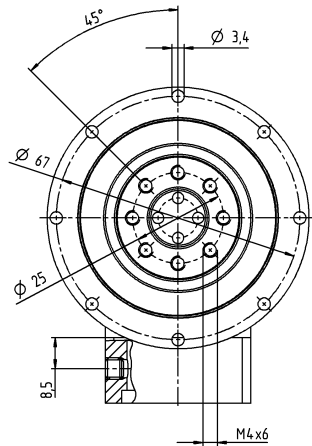

3-stage

up to 11⁴⁾ (B)⁵⁾
clamping hub
diameter

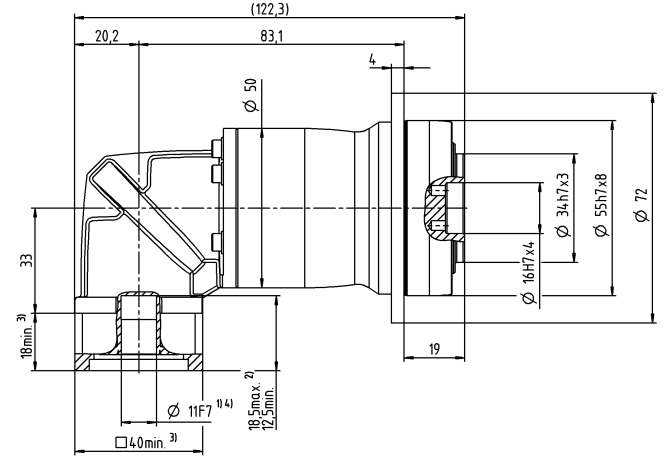
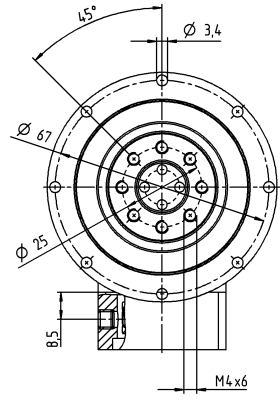

Motor shaft diameter [mm]

Non-tolerated dimensions are nominal dimensions
¹⁾ Check motor shaft fit
²⁾ Min. / Max. permissible motor shaft length
 Longer motor shafts are possible, please contact alpha
³⁾ The dimensions depend on the motor
⁴⁾ Smaller motor shaft diameter is compensated
 by a bushing with a minimum wall thickness of 1 mm
⁵⁾ Standard clamping hub diameter

Bevel Gearboxes
Value Line

NPTK 015 MF 2-stage

			2-stage							
Ratio	i		3	4	5	7	8	10		
Max. torque ^{a) b)}	T_{2a}	Nm	33	44	55	60	56	56		
		in.lb	292	389	487	531	496	496		
Max. acceleration torque (max. 1000 cycles per hour)	T_{2B}	Nm	16	21	27	37	35	35		
		in.lb	142	186	239	327	310	310		
Emergency stop torque ^{a) b)} (permitted 1000 times during the service life of the gearbox)	T_{2Not}	Nm	41	55	69	75	75	75		
		in.lb	363	487	611	664	664	664		
Permitted average input speed ^{d)} (at T_{2a} and 20 °C ambient temperature)	n_{1N}	rpm	3300	3300	3300	3300	3300	3300		
Max. input speed	n_{1Max}	rpm	5000	5000	5000	5000	5000	5000		
Mean no load running torque ^{b)} (at $n_1=3000$ rpm and 20 °C gearbox temperature)	T_{012}	Nm	0.55	0.55	0.55	0.55	0.55	0.55		
		in.lb	4.9	4.9	4.9	4.9	4.9	4.9		
Max. backlash	j_t	arcmin	≤ 15							
Torsional rigidity ^{b)}	C_{t21}	Nm/arcmin	2.4	2.4	2.4	2.4	2.4	2.4		
		in.lb/arcmin	21	21	21	21	21	21		
Max. axial force ^{c)}	F_{2AMax}	N	1380							
		lb _f	311							
Max. tilting moment	M_{2KMax}	Nm	42							
		in.lb	372							
Efficiency at full load	η	%	95							
Service life	L_n	h	> 20000							
Weight (incl. standard adapter plate)	m	kg	2.4							
		lb _m	5.3							
Operating noise (at reference ratio and reference speed – ratio-specific values available in cymex [®])	L_{PA}	dB(A)	≤ 70							
Max. permitted housing temperature		°C	+90							
		°F	+194							
Ambient temperature		°C	0 to +40							
		°F	+32 to +104							
Lubrication			Lubricated for life							
Direction of rotation			In- and output same direction							
Protection class			IP 64							
Elastomer coupling (recommended product type – validate sizing with cymex [®])			ELT-00060BAX-031.50							
Bore diameter of coupling on the application side		mm	X = 018.000 - 032.000							
Mass moment of inertia (relates to the drive) Clamping hub diameter [mm]	C	14	J_1	kgcm ²	0.34	0.34	0.34	0.34	0.34	0.34
				10 ⁻³ in.lb.s ²	0.3	0.3	0.3	0.3	0.3	0.3

Please use our sizing software cymex[®] for a detailed sizing – www.wittenstein-cymex.com
Please consider the maximal tilting moment caused by the motor M_{1KMot} – see sizing

^{a)} Valid for torque transmission only

^{b)} Valid for standard clamping hub diameter

^{c)} Refers to center of the output shaft or flange

^{d)} Please reduce input speed at higher ambient temperatures

Motor shaft diameter [mm]

2-stage

up to 14⁴⁾ (C)⁵⁾
clamping hub
diameter

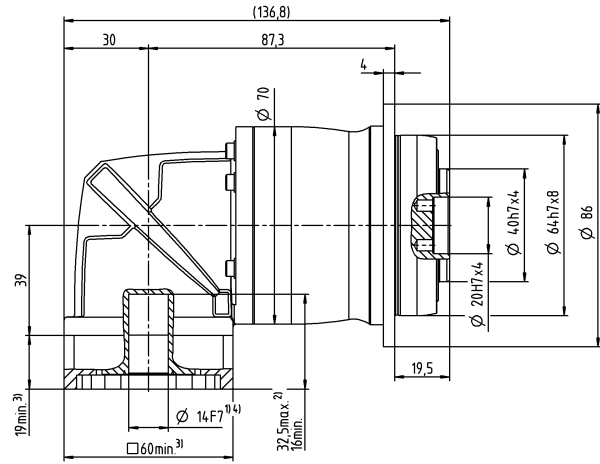
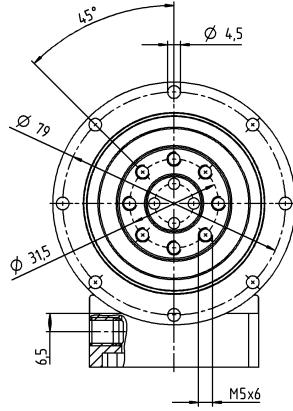

Non-tolerated dimensions are nominal dimensions

¹⁾ Check motor shaft fit

²⁾ Min. / Max. permissible motor shaft length

Longer motor shafts are possible, please contact alpha

³⁾ The dimensions depend on the motor

⁴⁾ Smaller motor shaft diameter is compensated by a bushing with a minimum wall thickness of 1 mm

⁵⁾ Standard clamping hub diameter

NPTK 015 MF 3-stage

			3-stage														
Ratio	i		12	15	16	20	25	28	30	32	35	40	50	64	70	100	
Max. torque ^{a) b)}	T_{2a}	Nm	42	51	56	56	60	56	51	56	60	56	60	56	60	56	
		in.lb	372	451	496	496	531	496	451	496	531	496	531	496	531	496	496
Max. acceleration torque (max. 1000 cycles per hour)	T_{2B}	Nm	20	25	27	34	40	35	31	35	40	35	40	35	40	35	
		in.lb	177	221	239	301	354	310	274	310	354	310	354	310	354	310	310
Emergency stop torque ^{a) b)} (permitted 1000 times during the service life of the gearbox)	T_{2Not}	Nm	52	65	70	75	75	75	75	75	75	75	75	75	75	75	
		in.lb	460	575	620	664	664	664	664	664	664	664	664	664	664	664	664
Permitted average input speed ^{d)} (at T_{2a} and 20 °C ambient temperature)	n_{1N}	rpm	3800	3800	3800	3800	3800	3800	3800	3800	3800	3800	3800	3800	3800	3800	
Max. input speed	n_{1Max}	rpm	5000	5000	5000	5000	5000	5000	5000	5000	5000	5000	5000	5000	5000	5000	
Mean no load running torque ^{b)} (at $n_1=3000$ rpm and 20 °C gearbox temperature)	T_{012}	Nm	0.26	0.26	0.26	0.26	0.26	0.26	0.26	0.26	0.26	0.26	0.26	0.26	0.26	0.26	
		in.lb	2.3	2.3	2.3	2.3	2.3	2.3	2.3	2.3	2.3	2.3	2.3	2.3	2.3	2.3	2.3
Max. backlash	j_t	arcmin	≤ 12														
Torsional rigidity ^{b)}	C_{121}	Nm/arcmin	3	3	3	3	3	3	3	3	3	3	3	3	3	3	
		in.lb/arcmin	27	27	27	27	27	27	27	27	27	27	27	27	27	27	27
Max. axial force ^{c)}	F_{2AMax}	N	1380														
		lb _f	311														
Max. tilting moment	M_{2KMax}	Nm	42														
		in.lb	372														
Efficiency at full load	η	%	94														
Service life	L_n	h	> 20000														
Weight (incl. standard adapter plate)	m	kg	2.5														
		lb _m	5.5														
Operating noise (at reference ratio and reference speed – ratio-specific values available in cymex®)	L_{PA}	dB(A)	≤ 68														
Max. permitted housing temperature		°C	+90														
		°F	+194														
Ambient temperature		°C	0 to +40														
		°F	+32 to +104														
Lubrication			Lubricated for life														
Direction of rotation			In- and output same direction														
Protection class			IP 64														
Elastomer coupling (recommended product type – validate sizing with cymex®)			ELT-00060BAX-031.50														
Bore diameter of coupling on the application side		mm	X = 018.000 - 032.000														
Mass moment of inertia (relates to the drive) Clamping hub diameter [mm]	B	11	J_1	kgcm ²	0.16	0.16	0.16	0.16	0.16	0.16	0.16	0.16	0.16	0.16	0.16	0.16	0.16
				10 ⁻³ in.lb.s ²	0.14	0.14	0.14	0.14	0.14	0.14	0.14	0.14	0.14	0.14	0.14	0.14	0.14

Please use our sizing software cymex® for a detailed sizing – www.wittenstein-cymex.com
Please consider the maximal tilting moment caused by the motor M_{1KMot} – see sizing

^{a)} Valid for torque transmission only

^{b)} Valid for standard clamping hub diameter

^{c)} Refers to center of the output shaft or flange

^{d)} Please reduce input speed at higher ambient temperatures

Motor shaft diameter [mm]

3-stage

up to 11⁴⁾ (B)⁵⁾
clamping hub diameter

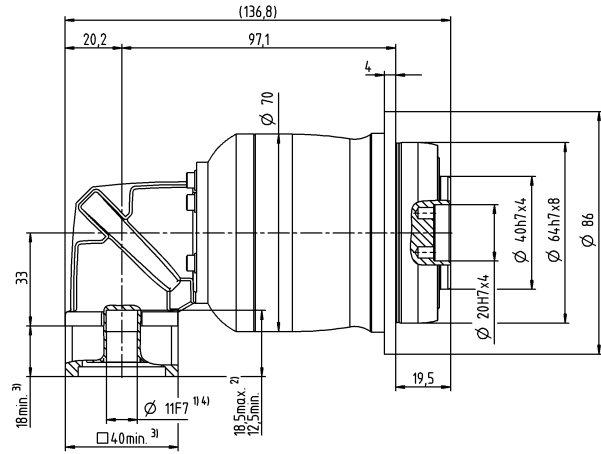
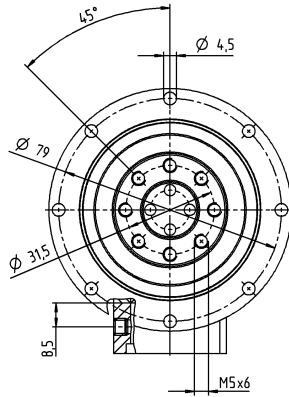

Non-tolerated dimensions are nominal dimensions

¹⁾ Check motor shaft fit

²⁾ Min. / Max. permissible motor shaft length

Longer motor shafts are possible, please contact alpha

³⁾ The dimensions depend on the motor

⁴⁾ Smaller motor shaft diameter is compensated by a bushing with a minimum wall thickness of 1 mm

⁵⁾ Standard clamping hub diameter

NPTK 025 MF 2-stage

			2-stage						
Ratio	i		3	4	5	7	8	10	
Max. torque ^{a) b)}	T_{2a}	Nm	60	80	100	140	144	144	
		in.lb	531	708	885	1239	1275	1275	
Max. acceleration torque (max. 1000 cycles per hour)	T_{2B}	Nm	35	47	58	82	90	90	
		in.lb	310	416	513	726	797	797	
Emergency stop torque ^{a) b)} (permitted 1000 times during the service life of the gearbox)	T_{2Not}	Nm	90	120	150	190	190	190	
		in.lb	797	1062	1328	1682	1682	1682	
Permitted average input speed ^{d)} (at T_{2a} and 20 °C ambient temperature)	n_{1N}	rpm	3000	3000	3000	3000	3000	3000	
Max. input speed	n_{1Max}	rpm	5000	5000	5000	5000	5000	5000	
Mean no load running torque ^{b)} (at $n_1=3000$ rpm and 20 °C gearbox temperature)	T_{012}	Nm	1	1	1	1	1	1	
		in.lb	8.9	8.9	8.9	8.9	8.9	8.9	
Max. backlash	j_t	arcmin	≤ 15						
Torsional rigidity ^{b)}	C_{t21}	Nm/arcmin	6.2	6.2	6.2	6.2	6.2	6.2	
		in.lb/arcmin	55	55	55	55	55	55	
Max. axial force ^{c)}	F_{2AMax}	N	1900						
		lb _f	428						
Max. tilting moment	M_{2KMax}	Nm	79						
		in.lb	699						
Efficiency at full load	η	%	95						
Service life	L_n	h	> 20000						
Weight (incl. standard adapter plate)	m	kg	5.5						
		lb _m	12						
Operating noise (at reference ratio and reference speed – ratio-specific values available in cymex [®])	L_{PA}	dB(A)	≤ 73						
Max. permitted housing temperature		°C	+90						
		°F	+194						
Ambient temperature		°C	0 to +40						
		°F	+32 to +104						
Lubrication			Lubricated for life						
Direction of rotation			In- and output same direction						
Protection class			IP 64						
Elastomer coupling (recommended product type – validate sizing with cymex [®])			ELT-00150BAX-050.00						
Bore diameter of coupling on the application side		mm	X = 024.000 - 036.000						
Mass moment of inertia (relates to the drive) Clamping hub diameter [mm]	E 19	J_1	kgcm ²	1.3	1.3	1.3	1.3	1.3	1.3
			10 ⁻³ in.lb.s ²	1.2	1.2	1.2	1.2	1.2	1.2

Please use our sizing software cymex[®] for a detailed sizing – www.wittenstein-cymex.com
Please consider the maximal tilting moment caused by the motor M_{1KMot} – see sizing

^{a)} Valid for torque transmission only

^{b)} Valid for standard clamping hub diameter

^{c)} Refers to center of the output shaft or flange

^{d)} Please reduce input speed at higher ambient temperatures

Motor shaft diameter [mm]

2-stage

up to 19⁴⁾ (E)⁵⁾
clamping hub diameter

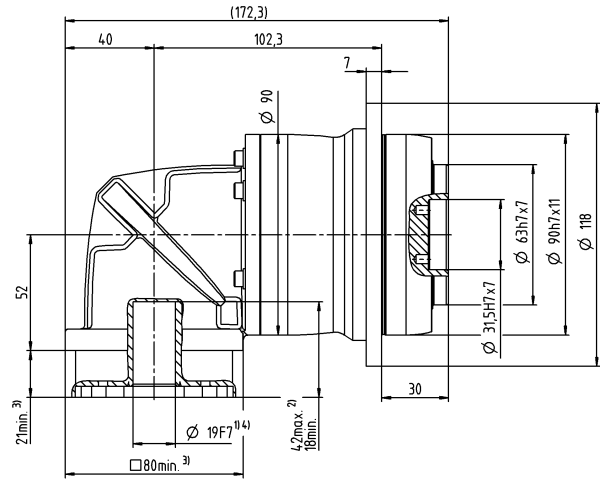
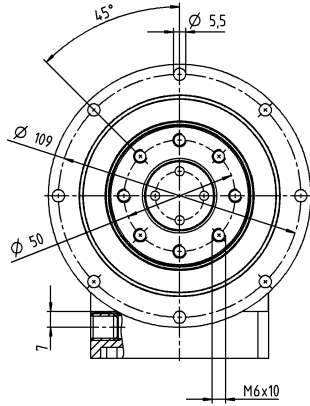

Non-tolerated dimensions are nominal dimensions

¹⁾ Check motor shaft fit

²⁾ Min. / Max. permissible motor shaft length

Longer motor shafts are possible, please contact alpha

³⁾ The dimensions depend on the motor

⁴⁾ Smaller motor shaft diameter is compensated by a bushing with a minimum wall thickness of 1 mm

⁵⁾ Standard clamping hub diameter

NPTK 025 MF 3-stage

			3-stage														
Ratio	i		9	12	15	16	20	25	28	30	32	35	40	50	64	70	100
Max. torque ^{a) b)}	T_{2a}	Nm	99	128	128	152	152	160	152	128	152	160	152	160	144	160	144
		in.lb	876	1133	1133	1345	1345	1416	1345	1133	1345	1416	1345	1416	1275	1416	1275
Max. acceleration torque (max. 1000 cycles per hour)	T_{2B}	Nm	48	65	80	86	95	100	95	80	95	100	95	100	90	100	90
		in.lb	425	575	708	761	841	885	841	708	841	885	841	885	797	885	797
Emergency stop torque ^{a) b)} (permitted 1000 times during the service life of the gearbox)	T_{2Not}	Nm	124	166	190	190	190	190	190	190	190	190	190	190	190	190	190
		in.lb	1097	1469	1682	1682	1682	1682	1682	1682	1682	1682	1682	1682	1682	1682	1682
Permitted average input speed ^{d)} (at T_{2a} and 20 °C ambient temperature)	n_{1N}	rpm	3300	3300	3300	3300	3300	3300	3300	3300	3300	3300	3300	3300	3300	3300	3300
Max. input speed	n_{1Max}	rpm	5000	5000	5000	5000	5000	5000	5000	5000	5000	5000	5000	5000	5000	5000	5000
Mean no load running torque ^{b)} (at $n_1 = 3000$ rpm and 20 °C gearbox temperature)	T_{012}	Nm	0.46	0.46	0.46	0.46	0.46	0.46	0.46	0.46	0.46	0.46	0.46	0.46	0.46	0.46	0.46
		in.lb	4.1	4.1	4.1	4.1	4.1	4.1	4.1	4.1	4.1	4.1	4.1	4.1	4.1	4.1	4.1
Max. backlash	j_t	arcmin	≤ 13														
Torsional rigidity ^{b)}	C_{t21}	Nm/arcmin	8.4	8.4	8.4	8.4	8.4	8.4	8.4	8.4	8.4	8.4	8.4	8.4	8.4	8.4	8.4
		in.lb/arcmin	74	74	74	74	74	74	74	74	74	74	74	74	74	74	74
Max. axial force ^{c)}	F_{2AMax}	N	1900														
		lb _f	428														
Max. tilting moment	M_{2KMax}	Nm	79														
		in.lb	699														
Efficiency at full load	η	%	94														
Service life	L_n	h	> 20000														
Weight (incl. standard adapter plate)	m	kg	5.1														
		lb _m	11														
Operating noise (at reference ratio and reference speed – ratio-specific values available in cymex®)	L_{PA}	dB(A)	≤ 70														
Max. permitted housing temperature		°C	+90														
		°F	+194														
Ambient temperature		°C	0 to +40														
		°F	+32 to +104														
Lubrication			Lubricated for life														
Direction of rotation			In- and output same direction														
Protection class			IP 64														
Elastomer coupling (recommended product type – validate sizing with cymex®)			ELT-00150BAX-050.00														
Bore diameter of coupling on the application side		mm	X = 024.000 - 036.000														
Mass moment of inertia (relates to the drive) Clamping hub diameter [mm]	C	14	J_1	kgcm ²	0.52	0.52	0.52	0.52	0.52	0.52	0.52	0.52	0.52	0.52	0.52	0.52	0.52
				10 ⁻³ in.lb.s ²	0.46	0.46	0.46	0.46	0.46	0.46	0.46	0.46	0.46	0.46	0.46	0.46	0.46

Please use our sizing software cymex® for a detailed sizing – www.wittenstein-cymex.com
Please consider the maximal tilting moment caused by the motor M_{1KMot} – see sizing

^{a)} Valid for torque transmission only

^{b)} Valid for standard clamping hub diameter

^{c)} Refers to center of the output shaft or flange

^{d)} Please reduce input speed at higher ambient temperatures

Motor shaft diameter [mm]

3-stage

up to 14⁴⁾ (C)⁵⁾
clamping hub
diameter

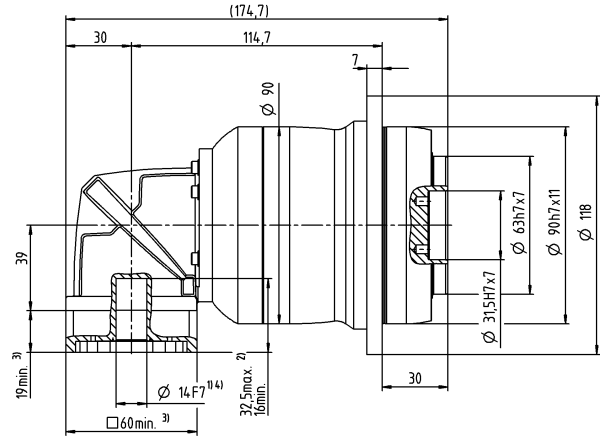
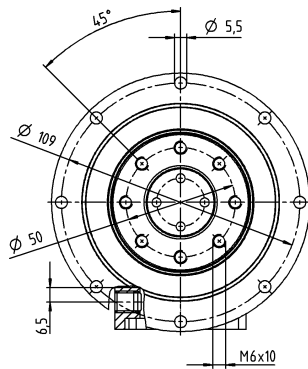

Non-tolerated dimensions are nominal dimensions

¹⁾ Check motor shaft fit

²⁾ Min. / Max. permissible motor shaft length

Longer motor shafts are possible, please contact alpha

³⁾ The dimensions depend on the motor

⁴⁾ Smaller motor shaft diameter is compensated by a bushing with a minimum wall thickness of 1 mm

⁵⁾ Standard clamping hub diameter

NPTK 035 MF 2-stage

			2-stage							
Ratio	i		3	4	5	7	8	10		
Max. torque ^{a) b)}	T_{2a}	Nm	150	200	250	350	352	352		
		in.lb	1328	1770	2213	3098	3115	3115		
Max. acceleration torque (max. 1000 cycles per hour)	T_{2B}	Nm	93	124	155	217	220	220		
		in.lb	823	1097	1372	1921	1947	1947		
Emergency stop torque ^{a) b)} (permitted 1000 times during the service life of the gearbox)	T_{2Not}	Nm	238	318	397	480	480	480		
		in.lb	2106	2815	3514	4248	4248	4248		
Permitted average input speed ^{d)} (at T_{2a} and 20 °C ambient temperature)	n_{1N}	rpm	2000	2000	2000	2000	2000	2000		
Max. input speed	n_{1Max}	rpm	4500	4500	4500	4500	4500	4500		
Mean no load running torque ^{b)} (at $n_1=3000$ rpm and 20 °C gearbox temperature)	T_{012}	Nm	4.2	4.2	4.2	4.2	4.2	4.2		
		in.lb	37	37	37	37	37	37		
Max. backlash	j_t	arcmin	≤ 13							
Torsional rigidity ^{b)}	C_{t21}	Nm/arcmin	16	16	16	16	16	16		
		in.lb/arcmin	142	142	142	142	142	142		
Max. axial force ^{c)}	F_{2AMax}	N	3500							
		lb _f	788							
Max. tilting moment	M_{2KMax}	Nm	134							
		in.lb	1186							
Efficiency at full load	η	%	95							
Service life	L_n	h	> 20000							
Weight (incl. standard adapter plate)	m	kg	11							
		lb _m	24							
Operating noise (at reference ratio and reference speed – ratio-specific values available in cymex®)	L_{PA}	dB(A)	≤ 74							
Max. permitted housing temperature		°C	+90							
		°F	+194							
Ambient temperature		°C	0 to +40							
		°F	+32 to +104							
Lubrication			Lubricated for life							
Direction of rotation			In- and output same direction							
Protection class			IP 64							
Elastomer coupling (recommended product type – validate sizing with cymex®)			ELT-00300BAX-063.00							
Bore diameter of coupling on the application side		mm	X = 035.000 - 045.000							
Mass moment of inertia (relates to the drive) Clamping hub diameter [mm]	H	28	J_1	kgcm ²	5.5	5.5	5.5	5.5	5.5	5.5
				10 ⁻³ in.lb.s ²	4.9	4.9	4.9	4.9	4.9	4.9

Please use our sizing software cymex® for a detailed sizing – www.wittenstein-cymex.com
Please consider the maximal tilting moment caused by the motor M_{1KMot} – see sizing

^{a)} Valid for torque transmission only

^{b)} Valid for standard clamping hub diameter

^{c)} Refers to center of the output shaft or flange

^{d)} Please reduce input speed at higher ambient temperatures

Motor shaft diameter [mm]

2-stage

up to 28⁴⁾ (H)⁵⁾
clamping hub diameter

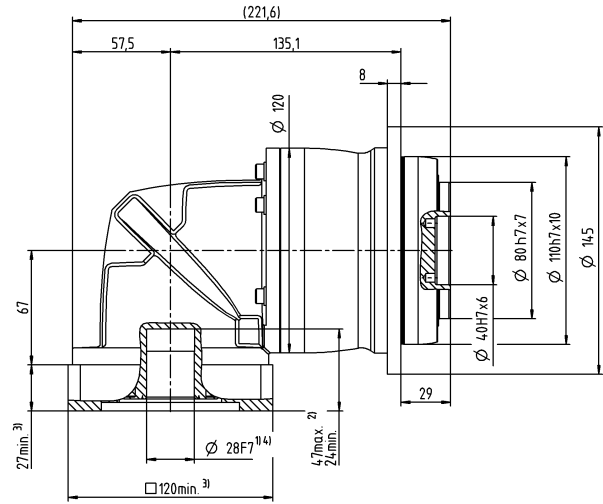
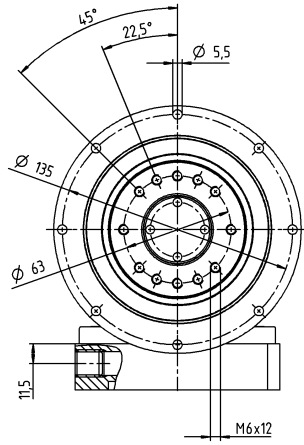

Non-tolerated dimensions are nominal dimensions

¹⁾ Check motor shaft fit

²⁾ Min. / Max. permissible motor shaft length

Longer motor shafts are possible, please contact alpha

³⁾ The dimensions depend on the motor

⁴⁾ Smaller motor shaft diameter is compensated by a bushing with a minimum wall thickness of 1 mm

⁵⁾ Standard clamping hub diameter

NPTK 035 MF 3-stage

			3-stage															
Ratio	i		9	12	15	16	20	25	28	30	32	35	40	50	64	70	100	
Max. torque ^{a) b)}	T_{2a}	Nm	180	240	300	320	365	365	365	320	365	365	365	365	352	365	352	
		in.lb	1593	2124	2655	2832	3231	3231	3231	2832	3231	3231	3231	3231	3115	3231	3115	
Max. acceleration torque (max. 1000 cycles per hour)	T_{2B}	Nm	105	141	176	188	235	250	255	200	255	250	255	250	220	250	220	
		in.lb	929	1248	1558	1664	2080	2213	2257	1770	2257	2213	2257	2213	1947	2213	1947	
Emergency stop torque ^{a) b)} (permitted 1000 times during the service life of the gearbox)	T_{2Not}	Nm	270	361	451	480	480	480	480	480	480	480	480	480	480	480	480	480
		in.lb	2390	3195	3992	4248	4248	4248	4248	4248	4248	4248	4248	4248	4248	4248	4248	4248
Permitted average input speed ^{d)} (at T_{2a} and 20 °C ambient temperature)	n_{1N}	rpm	3000	3000	3000	3000	3000	3000	3000	3000	3000	3000	3000	3000	3000	3000	3000	
Max. input speed	n_{1Max}	rpm	5000	5000	5000	5000	5000	5000	5000	5000	5000	5000	5000	5000	5000	5000	5000	
Mean no load running torque ^{b)} (at $n_1=3000$ rpm and 20 °C gearbox temperature)	T_{012}	Nm	1.2	1.2	1.2	1.2	1.2	1.2	1.2	1.2	1.2	1.2	1.2	1.2	1.2	1.2	1.2	
		in.lb	11	11	11	11	11	11	11	11	11	11	11	11	11	11	11	11
Max. backlash	j_t	arcmin	≤ 13															
Torsional rigidity ^{b)}	C_{21}	Nm/arcmin	19	19	19	19	19	19	19	19	19	19	19	19	19	19	19	
		in.lb/arcmin	168	168	168	168	168	168	168	168	168	168	168	168	168	168	168	168
Max. axial force ^{c)}	F_{2AMax}	N	3500															
		lb _f	788															
Max. tilting moment	M_{2KMax}	Nm	134															
		in.lb	1186															
Efficiency at full load	η	%	94															
Service life	L_n	h	> 20000															
Weight (incl. standard adapter plate)	m	kg	11															
		lb _m	24															
Operating noise (at reference ratio and reference speed – ratio-specific values available in cymex®)	L_{PA}	dB(A)	≤ 73															
Max. permitted housing temperature		°C	+90															
		°F	+194															
Ambient temperature		°C	0 to +40															
		°F	+32 to +104															
Lubrication			Lubricated for life															
Direction of rotation			In- and output same direction															
Protection class			IP 64															
Elastomer coupling (recommended product type – validate sizing with cymex®)			ELT-00300BAX-063.00															
Bore diameter of coupling on the application side		mm	X = 035.000 - 045.000															
Mass moment of inertia (relates to the drive) Clamping hub diameter [mm]	E	19	J_1	kgcm ²	1.9	1.9	1.9	1.9	1.9	1.9	1.9	1.9	1.9	1.9	1.9	1.9	1.9	
				10 ⁻³ in.lb.s ²	1.7	1.7	1.7	1.7	1.7	1.7	1.7	1.7	1.7	1.7	1.7	1.7	1.7	1.7

Please use our sizing software cymex® for a detailed sizing – www.wittenstein-cymex.com
Please consider the maximal tilting moment caused by the motor M_{1KMot} – see sizing

^{a)} Valid for torque transmission only

^{b)} Valid for standard clamping hub diameter

^{c)} Refers to center of the output shaft or flange

^{d)} Please reduce input speed at higher ambient temperatures

Motor shaft diameter [mm]

3-stage

up to 19⁴⁾ (E)⁵⁾
clamping hub diameter

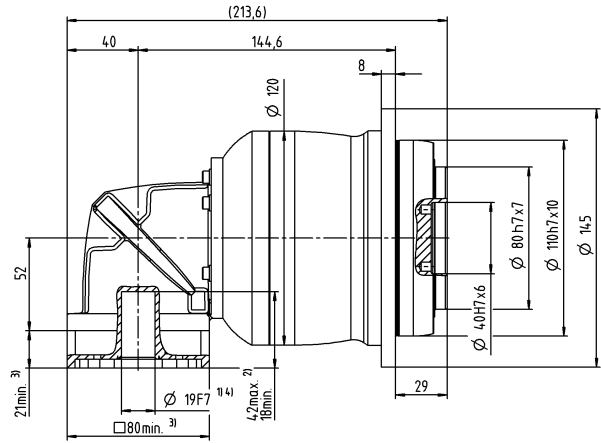
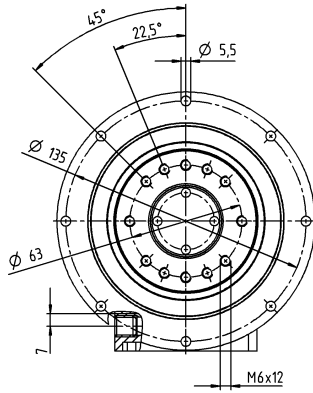

Non-tolerated dimensions are nominal dimensions

¹⁾ Check motor shaft fit

²⁾ Min. / Max. permissible motor shaft length

Longer motor shafts are possible, please contact alpha

³⁾ The dimensions depend on the motor

⁴⁾ Smaller motor shaft diameter is compensated

by a bushing with a minimum wall thickness of 1 mm

⁵⁾ Standard clamping hub diameter

NPTK 045 MF 3-stage

			3-stage					
Ratio	i		25	32	50	64	100	
Max. torque ^{a) b)}	T_{2a}	Nm	700	640	700	640	640	
		in.lb	6196	5665	6196	5665	5665	
Max. acceleration torque (max. 1000 cycles per hour)	T_{2B}	Nm	500	400	500	400	400	
		in.lb	4425	3540	4425	3540	3540	
Emergency stop torque ^{a) b)} (permitted 1000 times during the service life of the gearbox)	T_{2Not}	Nm	1000	1000	1000	1000	1000	
		in.lb	8851	8851	8851	8851	8851	
Permitted average input speed ^{d)} (at T_{2N} and 20 °C ambient temperature)	n_{1N}	rpm	2000	2000	2000	2000	2000	
Max. input speed	n_{1Max}	rpm	4500	4500	4500	4500	4500	
Mean no load running torque ^{b)} (at $n_1 = 3000$ rpm and 20 °C gearbox temperature)	T_{012}	Nm	3.1	3.1	3.1	3.1	3.1	
		in.lb	27	27	27	27	27	
Max. backlash	j_l	arcmin	≤ 11					
Torsional rigidity ^{b)}	C_{t21}	Nm/arcmin	54	54	54	54	54	
		in.lb/arcmin	478	478	478	478	478	
Max. axial force ^{c)}	F_{2AMax}	N	3800					
		lb _f	855					
Max. tilting moment	M_{2KMax}	Nm	256					
		in.lb	2266					
Efficiency at full load	η	%	94					
Service life	L_h	h	> 20000					
Weight (incl. standard adapter plate)	m	kg	21					
		lb _m	46					
Operating noise (at reference ratio and reference speed – ratio-specific values available in cymex®)	L_{pA}	dB(A)	≤ 74					
Max. permitted housing temperature		°C	+90					
		°F	+194					
Ambient temperature		°C	0 to +40					
		°F	+32 to +104					
Lubrication			Lubricated for life					
Direction of rotation			In- and output same direction					
Protection class			IP 64					
Elastomer coupling (recommended product type – validate sizing with cymex®)			ELT-00450BAX-080.00					
Bore diameter of coupling on the application side		mm	X = 042.000 - 060.000					
Mass moment of inertia (relates to the drive) Clamping hub diameter [mm]	H 28	J_1	kgcm ²	7.8	7.8	7.8	7.8	7.8
			10 ⁻³ in.lb.s ²	6.9	6.9	6.9	6.9	6.9

Please use our sizing software cymex® for a detailed sizing – www.wittenstein-cymex.com
Please consider the maximal tilting moment caused by the motor M_{1KMot} – see sizing

^{a)} Valid for torque transmission only

^{b)} Valid for standard clamping hub diameter

^{c)} Refers to center of the output shaft or flange

^{d)} Please reduce input speed at higher ambient temperatures

Motor shaft diameter [mm]

3-stage

up to 28⁴⁾ (H)⁵⁾
clamping hub diameter

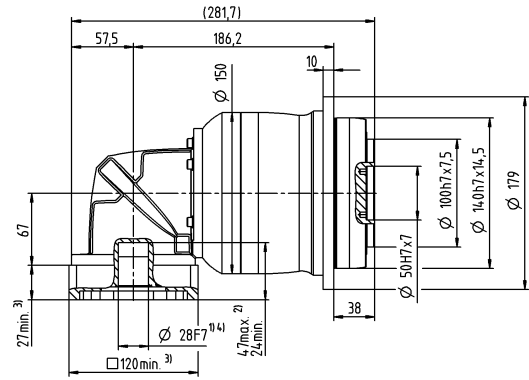
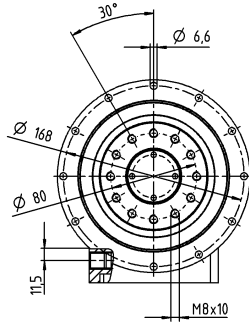

Non-tolerated dimensions are nominal dimensions

¹⁾ Check motor shaft fit

²⁾ Min. / Max. permissible motor shaft length

Longer motor shafts are possible, please contact alpha

³⁾ The dimensions depend on the motor

⁴⁾ Smaller motor shaft diameter is compensated by a bushing with a minimum wall thickness of 1 mm

⁵⁾ Standard clamping hub diameter

NPRK 015 MF 2-stage

			2-stage							
Ratio	i		3	4	5	7	8	10		
Max. torque ^{a) b) e)}	T_{2a}	Nm	33	44	55	64	56	56		
		in.lb	292	389	487	566	496	496		
Max. acceleration torque ^{b)} (max. 1000 cycles per hour)	T_{2B}	Nm	16	21	27	37	35	35		
		in.lb	142	186	239	327	310	310		
Emergency stop torque ^{a) b) e)} (permitted 1000 times during the service life of the gearbox)	T_{2Not}	Nm	41	55	69	80	80	80		
		in.lb	363	487	611	708	708	708		
Permitted average input speed ^{d)} (at T_{2a} and 20 °C ambient temperature)	n_{1N}	rpm	2600	2800	2900	3300	3300	3300		
Max. input speed	n_{1Max}	rpm	5000	5000	5000	5000	5000	5000		
Mean no load running torque ^{b)} (at $n_1=3000$ rpm and 20 °C gearbox temperature)	T_{012}	Nm	1.2	1.2	1.2	1.2	1.2	1.2		
		in.lb	11	11	11	11	11	11		
Max. backlash	j_t	arcmin	≤ 15							
Torsional rigidity ^{b)}	C_{t21}	Nm/arcmin	2.4	2.4	2.4	2.4	2.4	2.4		
		in.lb/arcmin	21	21	21	21	21	21		
Max. axial force ^{c)}	F_{2AMax}	N	2400							
		lb _f	540							
Max. lateral force ^{c)}	F_{2OMax}	N	2800							
		lb _f	630							
Max. tilting moment	M_{2KMMax}	Nm	152							
		in.lb	1345							
Efficiency at full load	η	%	95							
Service life	L_h	h	> 20000							
Weight (incl. standard adapter plate)	m	kg	2.3							
		lb _m	5.1							
Operating noise (at reference ratio and reference speed – ratio-specific values available in cymex®)	L_{PA}	dB(A)	≤ 70							
Max. permitted housing temperature		°C	+90							
		°F	+194							
Ambient temperature		°C	0 to +40							
		°F	+32 to +104							
Lubrication			Lubricated for life							
Direction of rotation			In- and output same direction							
Protection class			IP 64							
Elastomer coupling (recommended product type – validate sizing with cymex®)			ELC-0060BA016.000-X							
Bore diameter of coupling on the application side		mm	X = 012.000 - 032.000							
Mass moment of inertia (relates to the drive) Clamping hub diameter [mm]	C	14	J_1	kgcm ²	0.32	0.32	0.32	0.32	0.32	0.32
				10 ⁻³ in.lb.s ²	0.28	0.28	0.28	0.28	0.28	0.28

Please use our sizing software cymex® for a detailed sizing – www.wittenstein-cymex.com
Please consider the maximal tilting moment caused by the motor M_{1KMot} – see sizing

^{a)} Valid for torque transmission only

^{b)} Valid for standard clamping hub diameter

^{c)} Refers to center of the output shaft or flange

^{d)} Please reduce input speed at higher ambient temperatures

^{e)} Valid for: Smooth shaft

Motor shaft diameter [mm]

2-stage

up to 14⁴⁾ (C)⁵⁾
clamping hub
diameter

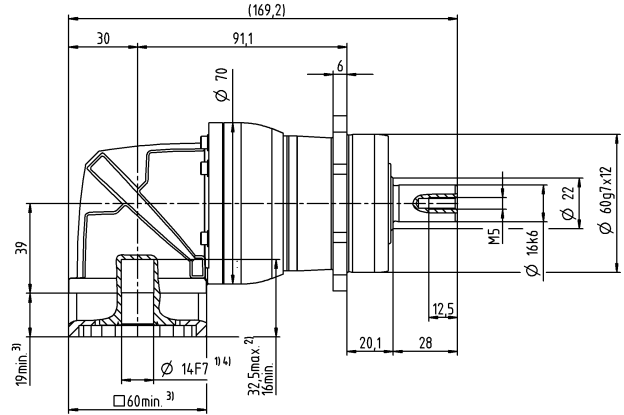
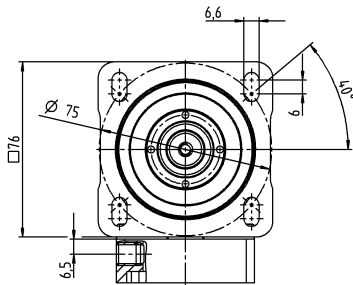

Other output variants

Shaft with key

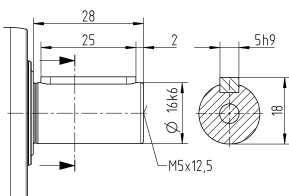

Splined shaft (DIN 5480)

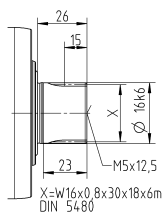

Non-tolerated dimensions are nominal dimensions

¹⁾ Check motor shaft fit

²⁾ Min. / Max. permissible motor shaft length

Longer motor shafts are possible, please contact alpha

³⁾ The dimensions depend on the motor

⁴⁾ Smaller motor shaft diameter is compensated

by a bushing with a minimum wall thickness of 1 mm

⁵⁾ Standard clamping hub diameter

NPRK 015 MF 3-stage

			3-stage													
Ratio	i		12	15	16	20	25	28	30	32	35	40	50	64	70	100
Max. torque ^{a) b) e)}	T_{2a}	Nm	42	51	56	56	64	56	51	56	64	56	64	56	64	56
		in.lb	372	451	496	496	566	496	451	496	566	496	566	496	566	496
Max. acceleration torque ^{b)} (max. 1000 cycles per hour)	T_{2B}	Nm	20	25	27	34	40	35	31	35	40	35	40	35	40	35
		in.lb	177	221	239	301	354	310	274	310	354	310	354	310	354	310
Emergency stop torque ^{a) b) e)} (permitted 1000 times during the service life of the gearbox)	T_{2Not}	Nm	52	65	70	80	80	80	80	80	80	80	80	80	80	80
		in.lb	460	575	620	708	708	708	708	708	708	708	708	708	708	708
Permitted average input speed ^{d)} (at T_{2a} and 20 °C ambient temperature)	n_{1N}	rpm	3800	3800	3800	3800	3800	3800	3800	3800	3800	3800	3800	3800	3800	3800
Max. input speed	n_{1Max}	rpm	5000	5000	5000	5000	5000	5000	5000	5000	5000	5000	5000	5000	5000	5000
Mean no load running torque ^{b)} (at $n_1 = 3000$ rpm and 20 °C gearbox temperature)	T_{012}	Nm	0.52	0.52	0.52	0.52	0.52	0.52	0.52	0.52	0.52	0.52	0.52	0.52	0.52	0.52
		in.lb	4.6	4.6	4.6	4.6	4.6	4.6	4.6	4.6	4.6	4.6	4.6	4.6	4.6	4.6
Max. backlash	j_t	arcmin	≤ 12													
Torsional rigidity ^{b)}	C_{t21}	Nm/arcmin	3	3	3	3	3	3	3	3	3	3	3	3	3	3
		in.lb/arcmin	27	27	27	27	27	27	27	27	27	27	27	27	27	27
Max. axial force ^{c)}	F_{2AMax}	N	2400													
		lb _f	540													
Max. lateral force ^{c)}	F_{2OMax}	N	2800													
		lb _f	630													
Max. tilting moment	M_{2KMMax}	Nm	152													
		in.lb	1345													
Efficiency at full load	η	%	94													
Service life	L_h	h	> 20000													
Weight (incl. standard adapter plate)	m	kg	2.4													
		lb _m	5.3													
Operating noise (at reference ratio and reference speed – ratio-specific values available in cymex®)	L_{PA}	dB(A)	≤ 68													
Max. permitted housing temperature		°C	+90													
		°F	+194													
Ambient temperature		°C	0 to +40													
		°F	+32 to +104													
Lubrication			Lubricated for life													
Direction of rotation			In- and output same direction													
Protection class			IP 64													
Elastomer coupling (recommended product type – validate sizing with cymex®)			ELC-0060BA016.000-X													
Bore diameter of coupling on the application side		mm	X = 012.000 - 032.000													
Mass moment of inertia (relates to the drive) Clamping hub diameter [mm]	B	11	J_1	kgcm ²	0.14	0.14	0.14	0.14	0.14	0.14	0.14	0.14	0.14	0.14	0.14	0.14
				10 ⁻³ in.lb.s ²	0.12	0.12	0.12	0.12	0.12	0.12	0.12	0.12	0.12	0.12	0.12	0.12

Please use our sizing software cymex® for a detailed sizing – www.wittenstein-cymex.com
Please consider the maximal tilting moment caused by the motor M_{1KMot} – see sizing

^{a)} Valid for torque transmission only

^{b)} Valid for standard clamping hub diameter

^{c)} Refers to center of the output shaft or flange

^{d)} Please reduce input speed at higher ambient temperatures

^{e)} Valid for: Smooth shaft

Motor shaft diameter [mm]

3-stage

up to 11⁴⁾ (B)⁵⁾
clamping hub
diameter

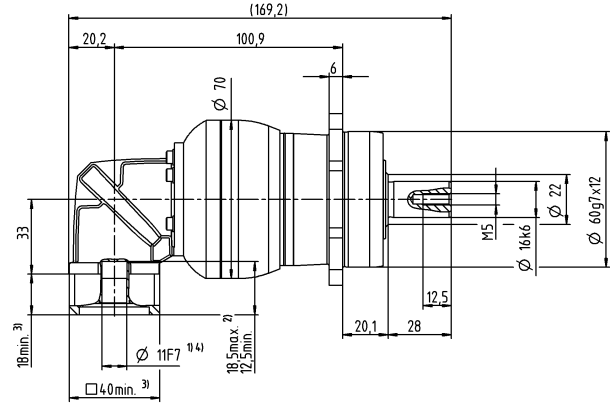
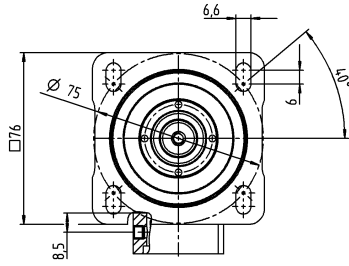

Other output variants

Shaft with key

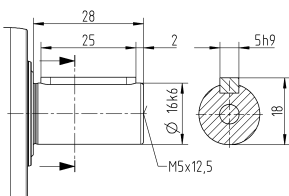

Splined shaft (DIN 5480)

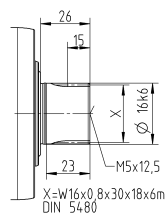

Non-tolerated dimensions are nominal dimensions

¹⁾ Check motor shaft fit

²⁾ Min. / Max. permissible motor shaft length

Longer motor shafts are possible, please contact alpha

³⁾ The dimensions depend on the motor

⁴⁾ Smaller motor shaft diameter is compensated

by a bushing with a minimum wall thickness of 1 mm

⁵⁾ Standard clamping hub diameter

NPRK 025 MF 2-stage

			2-stage						
Ratio	i		3	4	5	7	8	10	
Max. torque ^{a) b) e)}	T_{2a}	Nm	60	80	100	140	144	144	
		in.lb	531	708	885	1239	1275	1275	
Max. acceleration torque ^{b)} (max. 1000 cycles per hour)	T_{2B}	Nm	35	47	58	82	90	90	
		in.lb	310	416	513	726	797	797	
Emergency stop torque ^{a) b) e)} (permitted 1000 times during the service life of the gearbox)	T_{2Not}	Nm	90	120	150	190	190	190	
		in.lb	797	1062	1328	1682	1682	1682	
Permitted average input speed ^{d)} (at T_{2a} and 20 °C ambient temperature)	n_{1N}	rpm	2400	2600	2700	3000	3000	3000	
Max. input speed	n_{1Max}	rpm	5000	5000	5000	5000	5000	5000	
Mean no load running torque ^{b)} (at $n_1=3000$ rpm and 20 °C gearbox temperature)	T_{012}	Nm	2.4	2.4	2.4	2.4	2.4	2.4	
		in.lb	21	21	21	21	21	21	
Max. backlash	j_t	arcmin	≤ 15						
Torsional rigidity ^{b)}	C_{t21}	Nm/arcmin	6.2	6.2	6.2	6.2	6.2	6.2	
		in.lb/arcmin	55	55	55	55	55	55	
Max. axial force ^{c)}	F_{2AMax}	N	3350						
		lb _f	754						
Max. lateral force ^{c)}	F_{2OMax}	N	4200						
		lb _f	945						
Max. tilting moment	M_{2KMMax}	Nm	236						
		in.lb	2089						
Efficiency at full load	η	%	95						
Service life	L_h	h	> 20000						
Weight (incl. standard adapter plate)	m	kg	4.8						
		lb _m	11						
Operating noise (at reference ratio and reference speed – ratio-specific values available in cymex®)	L_{PA}	dB(A)	≤ 73						
Max. permitted housing temperature		°C	+90						
		°F	+194						
Ambient temperature		°C	0 to +40						
		°F	+32 to +104						
Lubrication			Lubricated for life						
Direction of rotation			In- and output same direction						
Protection class			IP 64						
Elastomer coupling (recommended product type – validate sizing with cymex®)			ELC-0060BA022.000-X						
Bore diameter of coupling on the application side		mm	X = 012.000 - 032.000						
Mass moment of inertia (relates to the drive) Clamping hub diameter [mm]	E 19	J_1	kgcm ²	1.2	1.2	1.2	1.2	1.2	1.2
			10 ⁻³ in.lb.s ²	1.1	1.1	1.1	1.1	1.1	1.1

Please use our sizing software cymex® for a detailed sizing – www.wittenstein-cymex.com
Please consider the maximal tilting moment caused by the motor M_{1KMot} – see sizing

^{a)} Valid for torque transmission only

^{b)} Valid for standard clamping hub diameter

^{c)} Refers to center of the output shaft or flange

^{d)} Please reduce input speed at higher ambient temperatures

^{e)} Valid for: Smooth shaft

Motor shaft diameter [mm]

2-stage

up to 19⁴⁾ (E)⁵⁾
clamping hub diameter

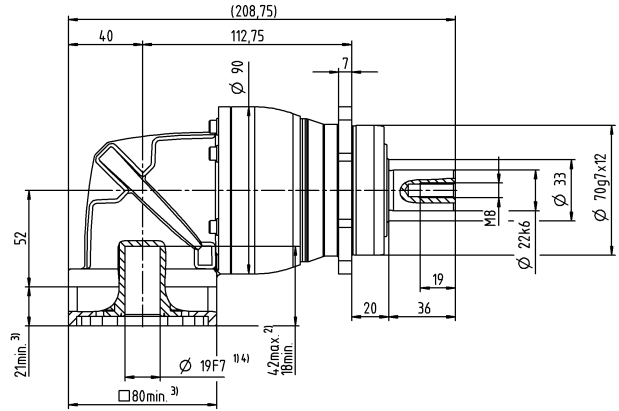
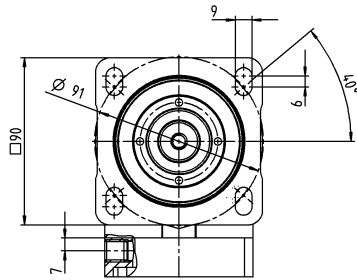

Other output variants

Shaft with key

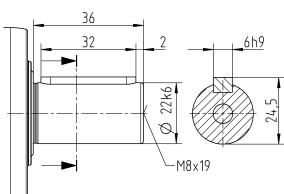

Splined shaft (DIN 5480)

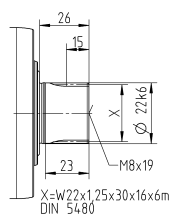

Non-tolerated dimensions are nominal dimensions

¹⁾ Check motor shaft fit

²⁾ Min. / Max. permissible motor shaft length

Longer motor shafts are possible, please contact alpha

³⁾ The dimensions depend on the motor

⁴⁾ Smaller motor shaft diameter is compensated by a bushing with a minimum wall thickness of 1 mm

⁵⁾ Standard clamping hub diameter

NPRK 025 MF 3-stage

			3-stage														
Ratio	i		9	12	15	16	20	25	28	30	32	35	40	50	64	70	100
Max. torque ^{a) b) e)}	T_{2a}	Nm	99	128	128	152	152	160	152	128	152	160	152	160	144	160	144
		in.lb	876	1133	1133	1345	1345	1416	1345	1133	1345	1416	1345	1416	1275	1416	1275
Max. acceleration torque ^{b)} (max. 1000 cycles per hour)	T_{2B}	Nm	48	65	80	86	95	100	95	80	95	100	95	100	90	100	90
		in.lb	425	575	708	761	841	885	841	708	841	885	841	885	797	885	797
Emergency stop torque ^{a) b) e)} (permitted 1000 times during the service life of the gearbox)	T_{2Not}	Nm	124	166	190	190	190	190	190	190	190	190	190	190	190	190	190
		in.lb	1097	1469	1682	1682	1682	1682	1682	1682	1682	1682	1682	1682	1682	1682	1682
Permitted average input speed ^{d)} (at T_{2a} and 20 °C ambient temperature)	n_{1N}	rpm	2800	3300	3300	3300	3300	3300	3300	3300	3300	3300	3300	3300	3300	3300	
Max. input speed	n_{1Max}	rpm	5000	5000	5000	5000	5000	5000	5000	5000	5000	5000	5000	5000	5000	5000	
Mean no load running torque ^{b)} (at $n_1=3000$ rpm and 20 °C gearbox temperature)	T_{012}	Nm	0.97	0.97	0.97	0.97	0.97	0.97	0.97	0.97	0.97	0.97	0.97	0.97	0.97	0.97	
		in.lb	8.6	8.6	8.6	8.6	8.6	8.6	8.6	8.6	8.6	8.6	8.6	8.6	8.6	8.6	
Max. backlash	j_t	arcmin	≤ 13														
Torsional rigidity ^{b)}	C_{121}	Nm/arcmin	8.4	8.4	8.4	8.4	8.4	8.4	8.4	8.4	8.4	8.4	8.4	8.4	8.4	8.4	
		in.lb/arcmin	74	74	74	74	74	74	74	74	74	74	74	74	74	74	
Max. axial force ^{c)}	F_{2AMax}	N	3350														
		lb _f	754														
Max. lateral force ^{c)}	F_{2OMax}	N	4200														
		lb _f	945														
Max. tilting moment	M_{2KMMax}	Nm	236														
		in.lb	2089														
Efficiency at full load	η	%	94														
Service life	L_h	h	> 20000														
Weight (incl. standard adapter plate)	m	kg	4.4														
		lb _m	9.7														
Operating noise (at reference ratio and reference speed – ratio-specific values available in cymex®)	L_{PA}	dB(A)	≤ 70														
Max. permitted housing temperature		°C	+90														
		°F	+194														
Ambient temperature		°C	0 to +40														
		°F	+32 to +104														
Lubrication			Lubricated for life														
Direction of rotation			In- and output same direction														
Protection class			IP 64														
Elastomer coupling (recommended product type – validate sizing with cymex®)			ELC-0060BA022.000-X														
Bore diameter of coupling on the application side		mm	X = 012.000 - 032.000														
Mass moment of inertia (relates to the drive) Clamping hub diameter [mm]	C	14	J_1	kgcm ²	0.45	0.45	0.45	0.45	0.45	0.45	0.45	0.45	0.45	0.45	0.45	0.45	0.45
				10 ⁻³ in.lb.s ²	0.4	0.4	0.4	0.4	0.4	0.4	0.4	0.4	0.4	0.4	0.4	0.4	0.4

Please use our sizing software cymex® for a detailed sizing – www.wittenstein-cymex.com
Please consider the maximal tilting moment caused by the motor M_{1KMot} – see sizing

^{a)} Valid for torque transmission only

^{b)} Valid for standard clamping hub diameter

^{c)} Refers to center of the output shaft or flange

^{d)} Please reduce input speed at higher ambient temperatures

^{e)} Valid for: Smooth shaft

Motor shaft diameter [mm]

3-stage

up to 14⁴⁾ (C)⁵⁾
clamping hub
diameter

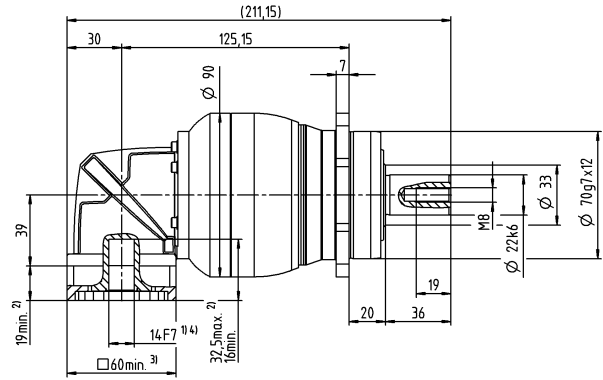
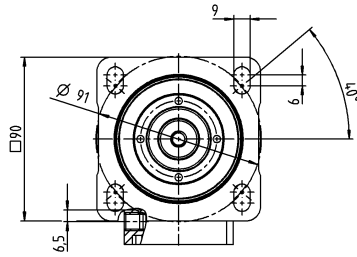

Other output variants

Shaft with key

Splined shaft (DIN 5480)

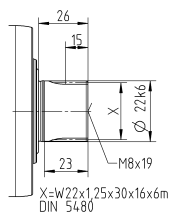
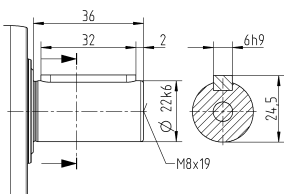

Non-tolerated dimensions are nominal dimensions

¹⁾ Check motor shaft fit

²⁾ Min. / Max. permissible motor shaft length

Longer motor shafts are possible, please contact alpha

³⁾ The dimensions depend on the motor

⁴⁾ Smaller motor shaft diameter is compensated

by a bushing with a minimum wall thickness of 1 mm

⁵⁾ Standard clamping hub diameter

NPRK 035 MF 2-stage

			2-stage						
Ratio	i		3	4	5	7	8	10	
Max. torque ^{a) b) e)}	T_{2a}	Nm	150	200	250	350	352	352	
		in.lb	1328	1770	2213	3098	3115	3115	
Max. acceleration torque ^{b)} (max. 1000 cycles per hour)	T_{2B}	Nm	93	124	155	217	220	220	
		in.lb	823	1097	1372	1921	1947	1947	
Emergency stop torque ^{a) b) e)} (permitted 1000 times during the service life of the gearbox)	T_{2Not}	Nm	238	318	397	500	500	500	
		in.lb	2106	2815	3514	4425	4425	4425	
Permitted average input speed ^{d)} (at T_{2a} and 20 °C ambient temperature)	n_{1N}	rpm	1800	2000	2000	2000	2000	2000	
Max. input speed	n_{1Max}	rpm	4500	4500	4500	4500	4500	4500	
Mean no load running torque ^{b)} (at $n_1=3000$ rpm and 20 °C gearbox temperature)	T_{012}	Nm	5.8	5.8	5.8	5.8	5.8	5.8	
		in.lb	51	51	51	51	51	51	
Max. backlash	j_t	arcmin	≤ 13						
Torsional rigidity ^{b)}	C_{t21}	Nm/arcmin	16	16	16	16	16	16	
		in.lb/arcmin	142	142	142	142	142	142	
Max. axial force ^{c)}	F_{2AMax}	N	5650						
		lb _f	1271						
Max. lateral force ^{c)}	F_{2OMax}	N	6600						
		lb _f	1485						
Max. tilting moment	M_{2KMMax}	Nm	487						
		in.lb	4310						
Efficiency at full load	η	%	95						
Service life	L_h	h	> 20000						
Weight (incl. standard adapter plate)	m	kg	10						
		lb _m	22						
Operating noise (at reference ratio and reference speed – ratio-specific values available in cymex®)	L_{PA}	dB(A)	≤ 74						
Max. permitted housing temperature		°C	+90						
		°F	+194						
Ambient temperature		°C	0 to +40						
		°F	+32 to +104						
Lubrication			Lubricated for life						
Direction of rotation			In- and output same direction						
Protection class			IP 64						
Elastomer coupling (recommended product type – validate sizing with cymex®)			ELC-0150BA032.000-X						
Bore diameter of coupling on the application side		mm	X = 019.000 - 036.000						
Mass moment of inertia (relates to the drive) Clamping hub diameter [mm]	H 28	J_1	kgcm ²	5.2	5.2	5.2	5.2	5.2	5.2
			10 ⁻³ in.lb.s ²	4.6	4.6	4.6	4.6	4.6	4.6

Please use our sizing software cymex® for a detailed sizing – www.wittenstein-cymex.com
Please consider the maximal tilting moment caused by the motor M_{1KMot} – see sizing

^{a)} Valid for torque transmission only

^{b)} Valid for standard clamping hub diameter

^{c)} Refers to center of the output shaft or flange

^{d)} Please reduce input speed at higher ambient temperatures

^{e)} Valid for: Smooth shaft

Motor shaft diameter [mm]

2-stage

up to 28⁴⁾ (H)⁵⁾
clamping hub diameter

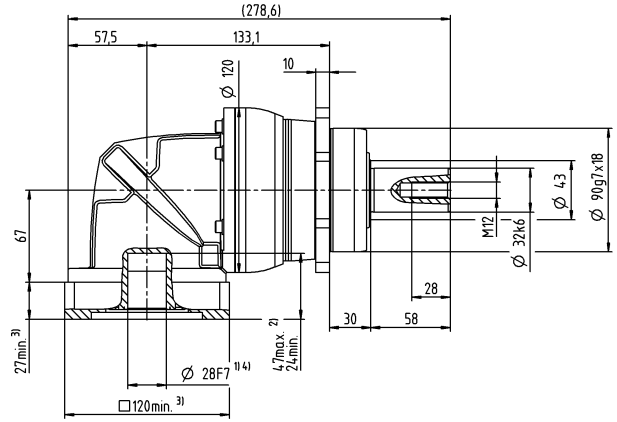
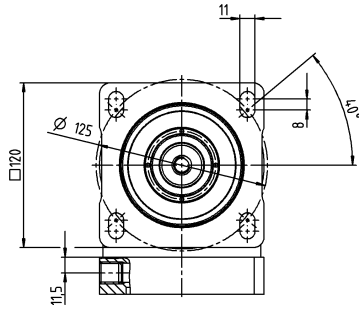

Bevel Gearboxes
Value Line

Other output variants

Shaft with key

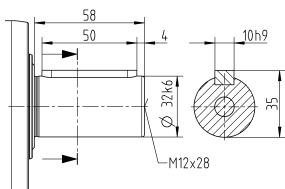

Splined shaft (DIN 5480)

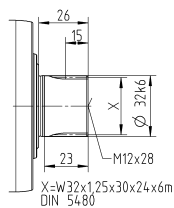

Non-tolerated dimensions are nominal dimensions

- ¹⁾ Check motor shaft fit
- ²⁾ Min. / Max. permissible motor shaft length
Longer motor shafts are possible, please contact alpha
- ³⁾ The dimensions depend on the motor
- ⁴⁾ Smaller motor shaft diameter is compensated by a bushing with a minimum wall thickness of 1 mm
- ⁵⁾ Standard clamping hub diameter

NPRK 035 MF 3-stage

			3-stage														
Ratio	i		9	12	15	16	20	25	28	30	32	35	40	50	64	70	100
Max. torque ^{a) b) e)}	T_{2a}	Nm	180	240	300	320	400	400	408	320	408	400	408	400	352	400	352
		in.lb	1593	2124	2655	2832	3540	3540	3611	2832	3611	3540	3611	3540	3115	3540	3115
Max. acceleration torque ^{b)} (max. 1000 cycles per hour)	T_{2B}	Nm	105	141	176	188	235	250	255	200	255	250	255	250	220	250	220
		in.lb	929	1248	1558	1664	2080	2213	2257	1770	2257	2213	2257	2213	1947	2213	1947
Emergency stop torque ^{a) b) e)} (permitted 1000 times during the service life of the gearbox)	T_{2Not}	Nm	270	361	451	481	500	500	500	500	500	500	500	500	500	500	500
		in.lb	2390	3195	3992	4257	4425	4425	4425	4425	4425	4425	4425	4425	4425	4425	4425
Permitted average input speed ^{d)} (at T_{2a} and 20 °C ambient temperature)	n_{1N}	rpm	2600	3000	3000	3000	3000	3000	3000	3000	3000	3000	3000	3000	3000	3000	3000
Max. input speed	n_{1Max}	rpm	5000	5000	5000	5000	5000	5000	5000	5000	5000	5000	5000	5000	5000	5000	5000
Mean no load running torque ^{b)} (at $n_1=3000$ rpm and 20 °C gearbox temperature)	T_{012}	Nm	2.3	2.3	2.3	2.3	2.3	2.3	2.3	2.3	2.3	2.3	2.3	2.3	2.3	2.3	2.3
		in.lb	20	20	20	20	20	20	20	20	20	20	20	20	20	20	20
Max. backlash	j_t	arcmin	≤ 13														
Torsional rigidity ^{b)}	C_{t21}	Nm/arcmin	19	19	19	19	19	19	19	19	19	19	19	19	19	19	19
		in.lb/arcmin	168	168	168	168	168	168	168	168	168	168	168	168	168	168	168
Max. axial force ^{c)}	F_{2AMax}	N	5650														
		lb _f	1271														
Max. lateral force ^{c)}	F_{2OMax}	N	6600														
		lb _f	1485														
Max. tilting moment	M_{2KMax}	Nm	487														
		in.lb	4310														
Efficiency at full load	η	%	94														
Service life	L_h	h	> 20000														
Weight (incl. standard adapter plate)	m	kg	10														
		lb _m	22														
Operating noise (at reference ratio and reference speed – ratio-specific values available in cymex®)	L_{PA}	dB(A)	≤ 73														
Max. permitted housing temperature		°C	+90														
		°F	+194														
Ambient temperature		°C	0 to +40														
		°F	+32 to +104														
Lubrication			Lubricated for life														
Direction of rotation			In- and output same direction														
Protection class			IP 64														
Elastomer coupling (recommended product type – validate sizing with cymex®)			ELC-0150BA032.000-X														
Bore diameter of coupling on the application side		mm	X = 019.000 - 036.000														
Mass moment of inertia (relates to the drive) Clamping hub diameter [mm]	E	19	J_1	kgcm ²	1.7	1.7	1.7	1.7	1.7	1.7	1.7	1.7	1.7	1.7	1.7	1.7	1.7
				10 ⁻³ in.lb.s ²	1.5	1.5	1.5	1.5	1.5	1.5	1.5	1.5	1.5	1.5	1.5	1.5	1.5

Please use our sizing software cymex® for a detailed sizing – www.wittenstein-cymex.com
Please consider the maximal tilting moment caused by the motor M_{1KMot} – see sizing

^{a)} Valid for torque transmission only

^{b)} Valid for standard clamping hub diameter

^{c)} Refers to center of the output shaft or flange

^{d)} Please reduce input speed at higher ambient temperatures

^{e)} Valid for: Smooth shaft

Motor shaft diameter [mm]

3-stage

up to 19⁴⁾ (E)⁵⁾
clamping hub diameter

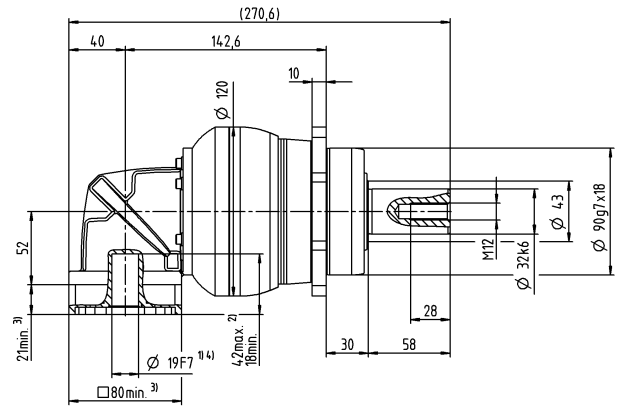
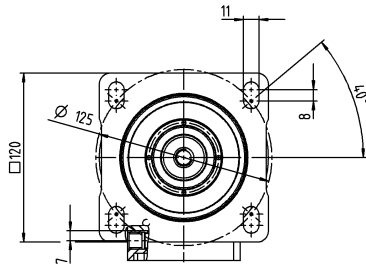

Other output variants

Shaft with key

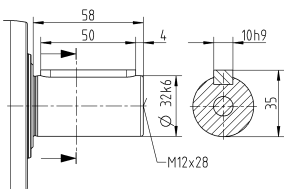

Splined shaft (DIN 5480)

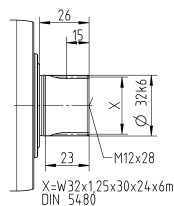

Non-tolerated dimensions are nominal dimensions

¹⁾ Check motor shaft fit

²⁾ Min. / Max. permissible motor shaft length

Longer motor shafts are possible, please contact alpha

³⁾ The dimensions depend on the motor

⁴⁾ Smaller motor shaft diameter is compensated by a bushing with a minimum wall thickness of 1 mm

⁵⁾ Standard clamping hub diameter

NPRK 045 MF 3-stage

			3-stage					
Ratio	i		25	32	50	64	100	
Max. torque ^{a) b) e)}	T_{2a}	Nm	700	640	700	640	640	
		in.lb	6196	5665	6196	5665	5665	
Max. acceleration torque ^{e)} (max. 1000 cycles per hour)	T_{2B}	Nm	500	400	500	400	400	
		in.lb	4425	3540	4425	3540	3540	
Emergency stop torque ^{a) b) e)} (permitted 1000 times during the service life of the gearbox)	T_{2Not}	Nm	1000	1000	1000	1000	1000	
		in.lb	8851	8851	8851	8851	8851	
Permitted average input speed ^{d)} (at T_{2N} and 20 °C ambient temperature)	n_{1N}	rpm	2000	2000	2000	2000	2000	
Max. input speed	n_{1Max}	rpm	4500	4500	4500	4500	4500	
Mean no load running torque ^{b)} (at $n_1=3000$ rpm and 20 °C gearbox temperature)	T_{012}	Nm	4.7	4.7	4.7	4.7	4.7	
		in.lb	42	42	42	42	42	
Max. backlash	j_l	arcmin	≤ 11					
Torsional rigidity ^{b)}	C_{121}	Nm/arcmin	54	54	54	54	54	
		in.lb/arcmin	478	478	478	478	478	
Max. axial force ^{c)}	F_{2AMax}	N	9870					
		lb _f	2221					
Max. lateral force ^{c)}	F_{2QMMax}	N	9900					
		lb _f	2228					
Max. tilting moment	M_{2KMMax}	Nm	952					
		in.lb	8426					
Efficiency at full load	η	%	94					
Service life	L_n	h	> 20000					
Weight (incl. standard adapter plate)	m	kg	21					
		lb _m	46					
Operating noise (at reference ratio and reference speed – ratio-specific values available in cymex®)	L_{PA}	dB(A)	≤ 74					
Max. permitted housing temperature		°C	+90					
		°F	+194					
Ambient temperature		°C	0 to +40					
		°F	+32 to +104					
Lubrication			Lubricated for life					
Direction of rotation			In- and output same direction					
Protection class			IP 64					
Elastomer coupling (recommended product type – validate sizing with cymex®)			ELC-0300BA040.000-X					
Bore diameter of coupling on the application side		mm	X = 020.000 - 045.000					
Mass moment of inertia (relates to the drive) Clamping hub diameter [mm]	H 28	J_1	kgcm ²	6.7	6.7	6.7	6.7	6.7
			10 ⁻³ in.lb.s ²	5.9	5.9	5.9	5.9	5.9

Please use our sizing software cymex® for a detailed sizing – www.wittenstein-cymex.com
Please consider the maximal tilting moment caused by the motor M_{1KMot} – see sizing

^{a)} Valid for torque transmission only

^{b)} Valid for standard clamping hub diameter

^{c)} Refers to center of the output shaft or flange

^{d)} Please reduce input speed at higher ambient temperatures

^{e)} Valid for: Smooth shaft

Motor shaft diameter [mm]

3-stage

up to 28⁴⁾ (H)⁵⁾
clamping hub diameter

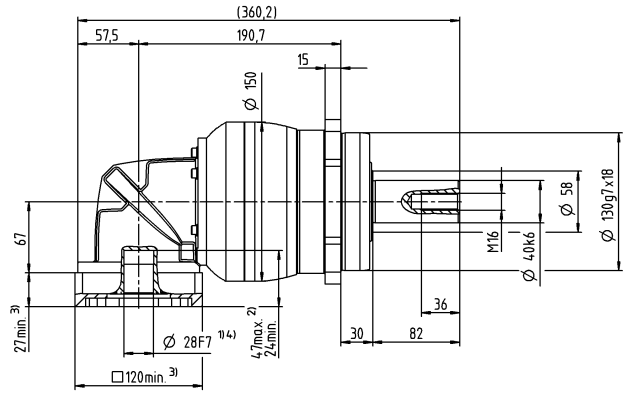
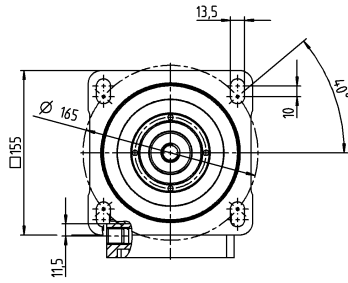

Other output variants

Shaft with key

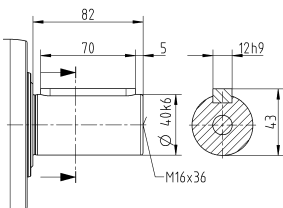

Splined shaft (DIN 5480)

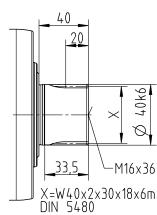

Non-tolerated dimensions are nominal dimensions

¹⁾ Check motor shaft fit

²⁾ Min. / Max. permissible motor shaft length

Longer motor shafts are possible, please contact alpha

³⁾ The dimensions depend on the motor

⁴⁾ Smaller motor shaft diameter is compensated

by a bushing with a minimum wall thickness of 1 mm

⁵⁾ Standard clamping hub diameter

alpha Value Line

WORM GEARBOXES NVH / NVS

This product line is characterized by high power density, medium backlash over the entire service life, and supreme running smoothness. The gearboxes are also ideal for use in continuous operation thanks to their low temperature development.

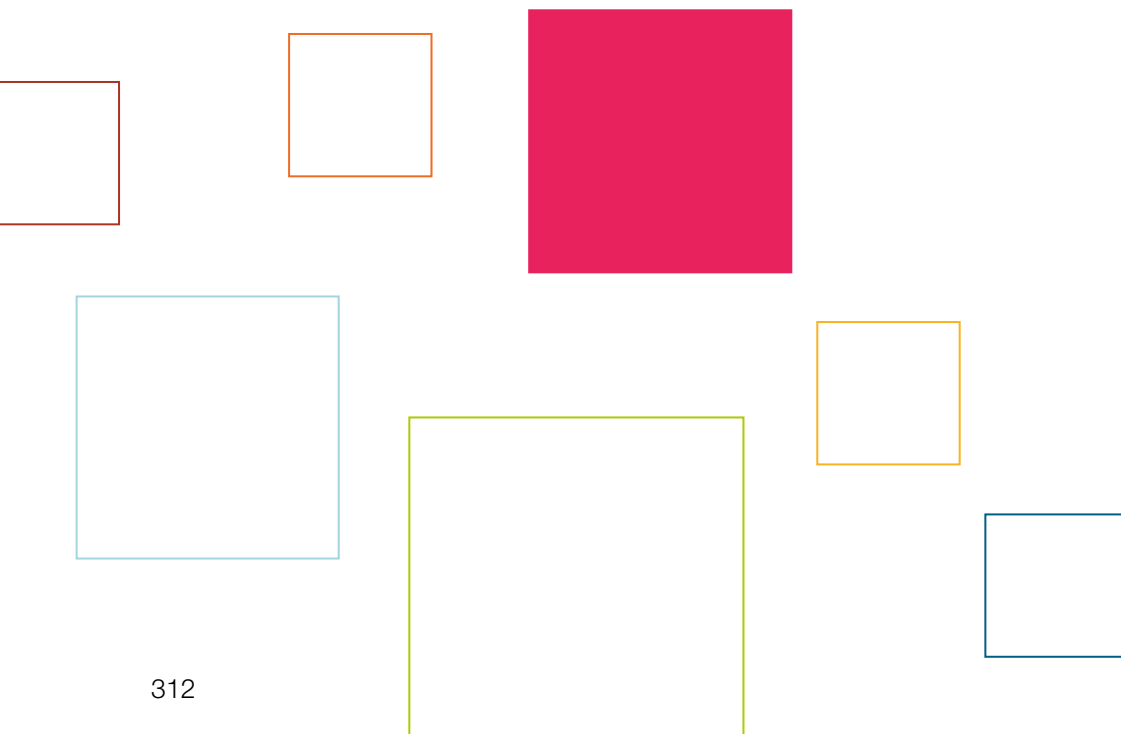

NVH

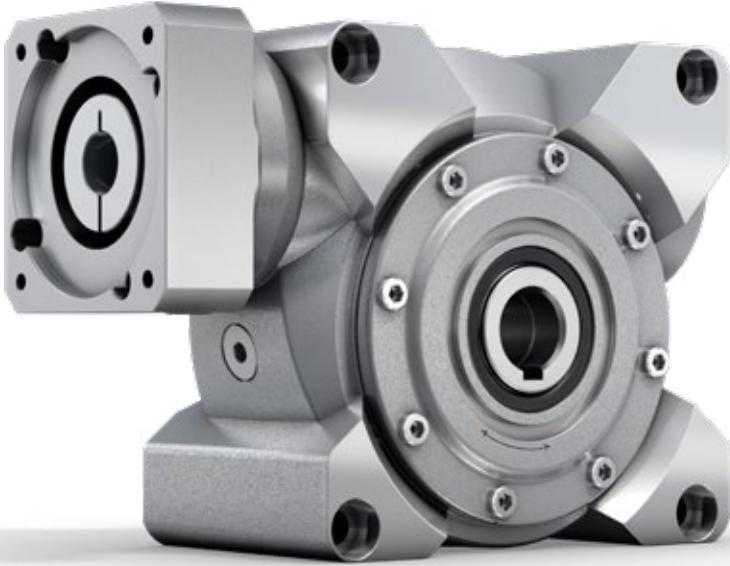

NVS

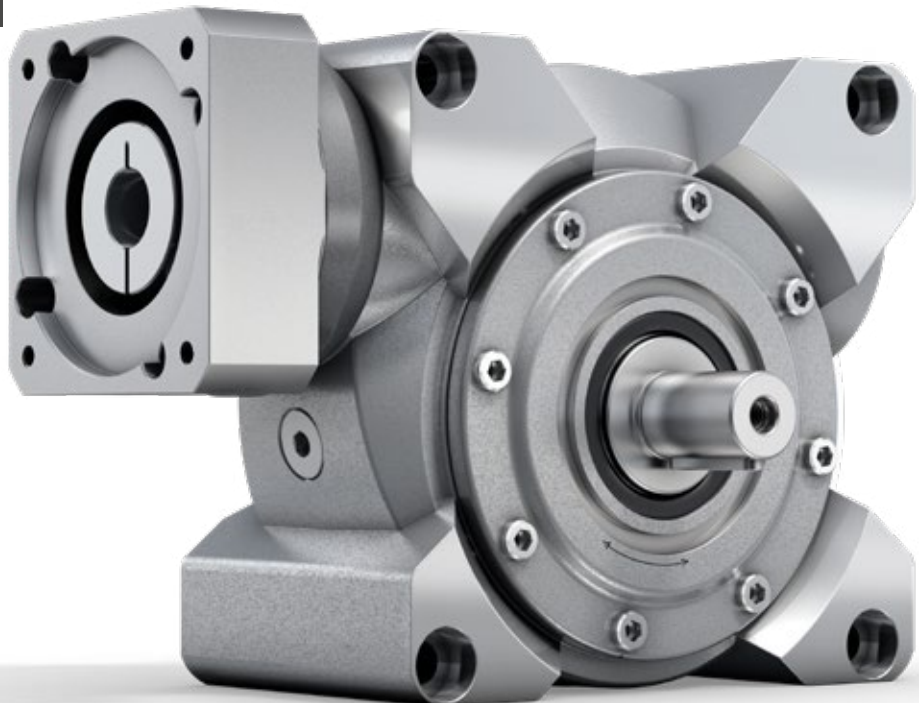

NVH / NVS – We drive the Performance

NVH

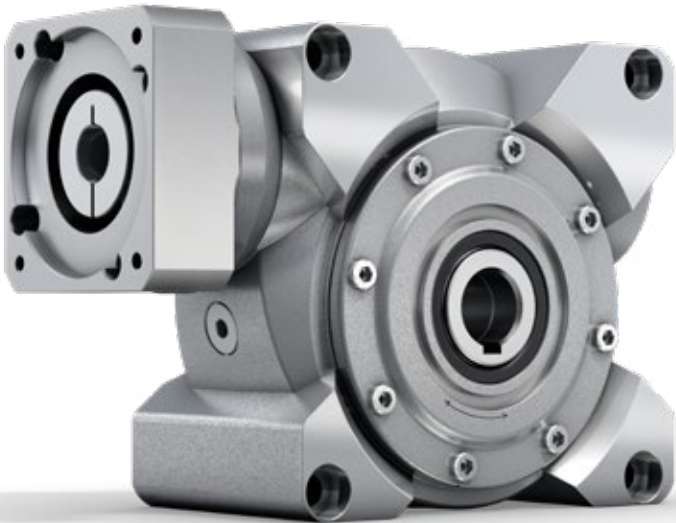

The servo worm gearboxes with hollow shaft and output shaft impress with high power density combined with medium backlash. The V-Drive Value are especially suitable for economical applications in continuous operation.

PRODUCT HIGHLIGHTS



Strong performance

The V-Drive Value convinces with a strong performance in economical standard applications in cyclic and continuous operation.

High power density is achieved with medium backlash over the entire service life.



No stick-slip effect

The stick-slip effect is not an issue in applications with the V-Drive Value thanks to the perfected hollow-flank toothing.

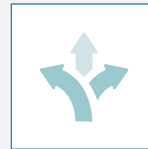

High flexibility

In addition to the hollow shaft and shaft output shapes, the worm gearboxes are also available in a corrosion-resistant design.



Constant low backlash

Constant low backlash over the entire service life affords consistent high quality with high positioning accuracy.



NVH – worm gearbox in corrosion-resistant design



NVS – worm gearbox with integrated planetary input stage

NVS

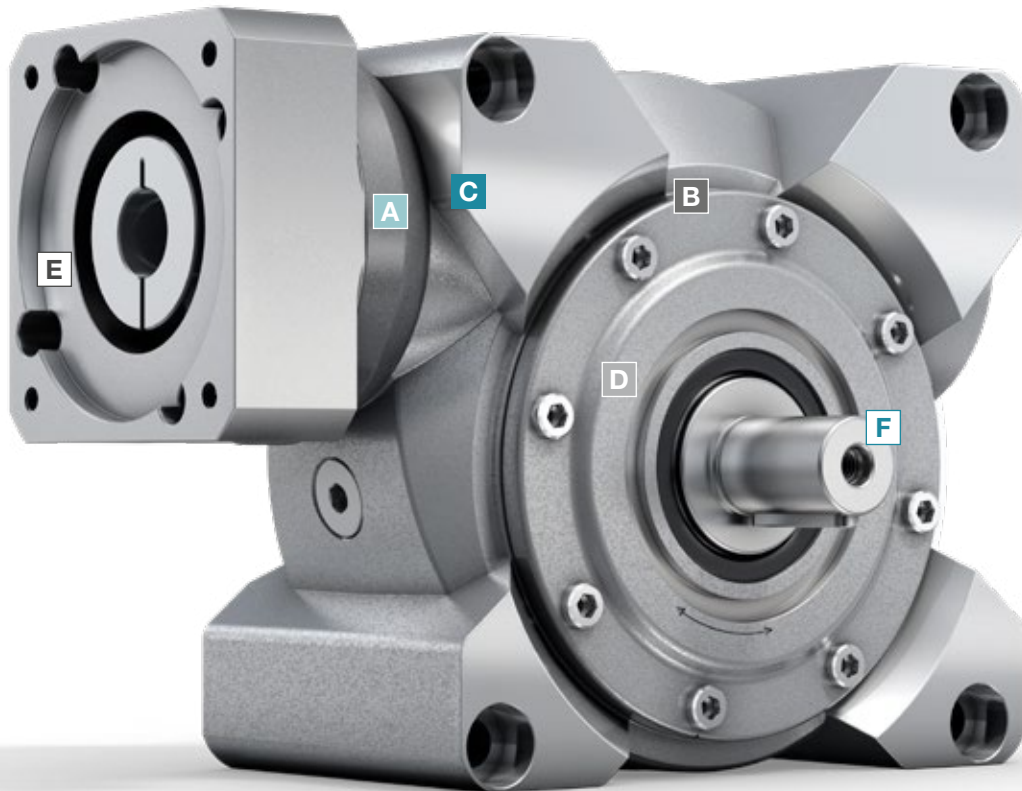

- A Radial shaft seal**
- Very long service life
 - Optimized for continuous operation

- B Hollow-flank toothing**
- Medium torsional backlash accuracy over the entire service life
 - High efficiency
 - High power density

- C Input bearing**
- Bearing package to absorb axial and radial forces
 - Very well suited to high input speeds

- D Output bearing**
- High overload capacity to absorb axial and radial forces

- E Metal bellows coupling**
- Completely backlash free
 - Lifetime durable and maintenance free
 - Easy assembly
 - Protects the motor through thermal linear expansion compensation

- F Multiple output configurations for greater flexibility**
- Hollow shaft interface
 - Keyed hollow shaft
 - Output on both sides
 - Smooth shaft
 - Shaft with key



NVS – worm gearbox with elastomer coupling ELC



NVS – worm gearbox with rack and pinion

NVH 040 MF 1-/2-stage

			1-stage						2-stage								
Ratio	<i>i</i>		4	7	10	16	28	40	50	70	100	140	200	280	400		
Max. torque ^{a) b)} (at $n_1 = 500$ rpm)	T_{2a}	Nm	74	82	91	94	98	91	91	82	91	98	91	98	91		
		in.lb	655	726	805	832	867	805	805	726	805	867	805	867	805		
Emergency stop torque ^{a) b)} (permitted 1000 times during the service life of the gearbox)	T_{2Not}	Nm	118	126	125	129	134	122	125	126	125	134	122	134	122		
		in.lb	1044	1115	1106	1142	1186	1080	1106	1115	1106	1186	1080	1186	1080		
Permitted average input speed ^{d)} (at 20 °C ambient temperature)	n_{1N}	rpm	4000						4400								
Max. input speed	n_{1Max}	rpm	6000														
Mean no load running torque ^{b)} (at $n_1 = 3000$ rpm and 20 °C gearbox temperature)	T_{012}	Nm	0.8	0.7	0.6	0.5	0.4	0.4	0.4	0.2	0.2	0.4	0.4	0.3	0.2		
		in.lb	7.1	6.2	5.3	4.4	3.5	3.5	3.5	1.8	1.8	3.5	3.5	2.7	1.8		
Max. backlash	j_t	arcmin	≤ 6						≤ 7								
Torsional rigidity ^{b)}	C_{t21}	Nm/arcmin	4.5	4.5	4.5	4.5	4.5	4.5	4.5	4.5	4.5	4.5	4.5	4.5	4.5		
		in.lb/arcmin	40	40	40	40	40	40	40	40	40	40	40	40	40		
Max. axial force ^{c)}	F_{2AMax}	N	3000														
		lb _f	675														
Max. lateral force ^{b)}	F_{2OMax}	N	2400														
		lb _f	540														
Max. tilting moment	M_{2KMax}	Nm	205														
		in.lb	1814														
Efficiency at full load (at $n_1 = 500$ rpm)	η	%	93	90	88	82	73	67	86	88	86	71	65	71	65		
Service life	L_n	h	> 20000														
Weight (incl. standard adapter plate)	m	kg	5						5.6								
		lb _m	11.1						12								
Operating noise (at reference ratio and reference speed – ratio-specific values available in cymex [®])	L_{PA}	dB(A)	< 54						< 58								
Max. permitted housing temperature		°C	+90														
		°F	+194														
Ambient temperature		°C	-15 to +40														
		°F	+5 to +104														
Lubrication			Lubricated for life														
Direction of rotation			See drawing														
Protection class			IP 65														
Shrink disc (Standard Version)			SD 024x050 S2														
Max. torque (without axial force)	T_{max}	Nm	250														
		in.lb	2213														
Mass moment of inertia (relates to the drive)	C	14	J_1	kgcm ²	0.56	0.42	0.39	0.37	0.36	0.35	0.16	0.15	0.15	0.16	0.16	0.15	0.15
				10 ⁻³ in.lb.s ²	0.5	0.37	0.35	0.33	0.32	0.31	0.14	0.13	0.13	0.14	0.14	0.13	0.13
Clamping hub diameter [mm]	E	19	J_1	kgcm ²	0.88	0.74	0.7	0.68	0.68	0.67	0.53	0.52	0.52	0.53	0.53	0.52	0.52
				10 ⁻³ in.lb.s ²	0.78	0.65	0.62	0.6	0.6	0.59	0.47	0.46	0.46	0.47	0.47	0.46	0.46

Please use our sizing software cymex[®] for a detailed sizing – www.wittenstein-cymex.com

^{a)} At max. 10 % F_{2OMax}

^{b)} Valid for standard clamping hub diameter

^{c)} Refers to center of the output shaft or flange

^{d)} Please reduce input speed at higher ambient temperatures

1-stage

up to 14/19⁴⁾ (C⁶⁾/E)
clamping hub diameter

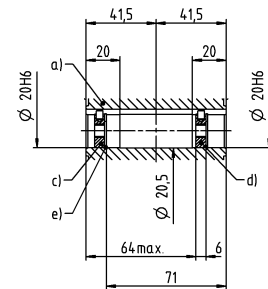
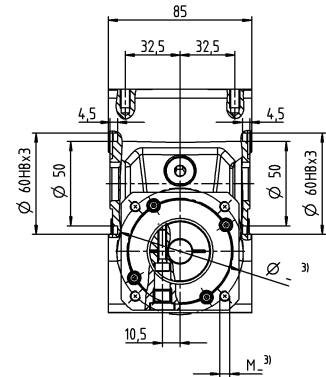
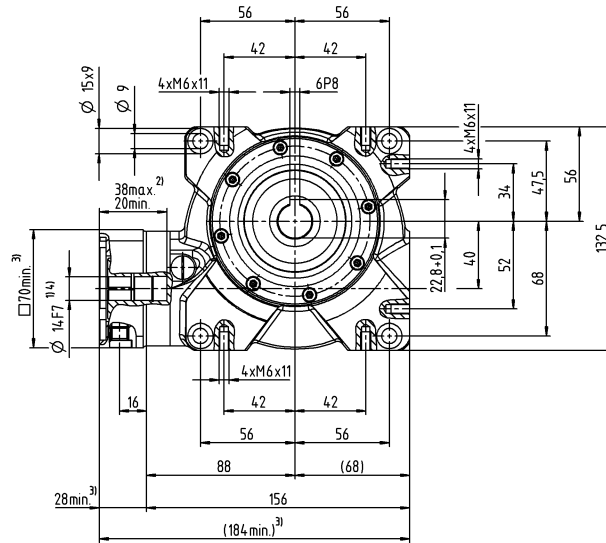

Motor shaft diameter [mm]

2-stage

up to 14/19⁴⁾ (C⁶⁾/E)
clamping hub diameter

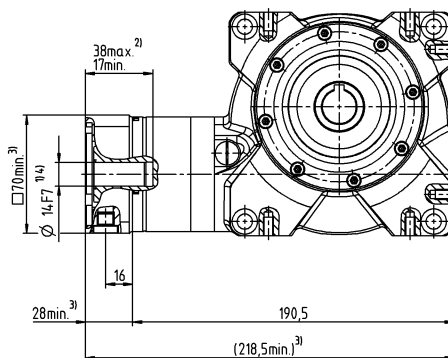

Other output variants

Hollow shaft interfaces on both sides

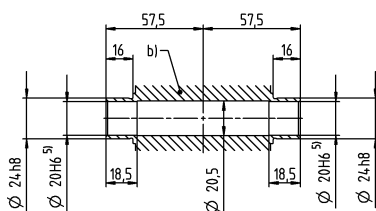

- a) Hollow shaft, keyed on both sides
- b) Hollow shaft interfaces on both sides
- c) End disc for screw M6 (on request)
- d) End disc as forcing washer for screw M8 (on request)
- e) Locking ring – DIN 472 (on request)

See technical data sheet for available clamping hub diameters (mass moment of inertia). Dimensions available on request.

Non-tolerated dimensions are nominal dimensions

- ¹⁾ Check motor shaft fit
- ²⁾ Min./Max. permissible motor shaft length
Longer motor shafts are adaptable, please contact us
- ³⁾ The dimensions depend on the motor
- ⁴⁾ Smaller motor shaft diameter is compensated by a bushing with a minimum wall thickness of 1 mm
- ⁵⁾ Tolerance h6 for mounted shaft
- ⁶⁾ Standard clamping hub diameter

NVH 050 MF 1-/2-stage

			1-stage						2-stage								
Ratio	i		4	7	10	16	28	40	50	70	100	140	200	280	400		
Max. torque ^{a) b)} (at $n_1 = 500$ rpm)	T_{2a}	Nm	130	150	153	157	167	141	153	150	153	167	141	167	141		
		in.lb	1151	1328	1354	1389	1478	1248	1354	1328	1354	1478	1248	1478	1248		
Emergency stop torque ^{a) b)} (permitted 1000 times during the service life of the gearbox)	T_{2Not}	Nm	230	242	242	250	262	236	242	242	242	262	236	262	236		
		in.lb	2036	2142	2142	2213	2319	2089	2142	2142	2142	2319	2089	2319	2089		
Permitted average input speed ^{d)} (at 20 °C ambient temperature)	n_{1N}	rpm	4000						3500								
Max. input speed	n_{1Max}	rpm	6000														
Mean no load running torque ^{b)} (at $n_1 = 3000$ rpm and 20 °C gearbox temperature)	T_{012}	Nm	2.3	2.2	1.6	1.5	1.2	1.1	0.7	0.5	0.4	0.6	0.6	0.4	0.4		
		in.lb	20.4	19.5	14.2	13.3	10.6	9.7	6.2	4.4	3.5	5.3	5.3	3.5	3.5		
Max. backlash	j_t	arcmin	≤ 6						≤ 7								
Torsional rigidity ^{b)}	C_{t21}	Nm/arcmin	8	8	8	8	8	8	8	8	8	8	8	8	8		
		in.lb/arcmin	71	71	71	71	71	71	71	71	71	71	71	71	71		
Max. axial force ^{c)}	F_{2AMax}	N	5000														
		lb _f	1125														
Max. lateral force ^{b)}	F_{2QMMax}	N	3800														
		lb _f	855														
Max. tilting moment	M_{2KMMax}	Nm	409														
		in.lb	3620														
Efficiency at full load (at $n_1 = 500$ rpm)	η	%	92	89	86	82	72	64	84	87	84	70	62	70	62		
Service life	L_n	h	> 20000														
Weight (incl. standard adapter plate)	m	kg	8						8.7								
		lb _m	17.7						19								
Operating noise (at reference ratio and reference speed – ratio-specific values available in cymex [®])	L_{PA}	dB(A)	≤ 62														
Max. permitted housing temperature		°C	+90														
		°F	+194														
Ambient temperature		°C	-15 to +40														
		°F	+5 to +104														
Lubrication			Lubricated for life														
Direction of rotation			See drawing														
Protection class			IP 65														
Shrink disc (Standard Version)			SD 030x060 S2V														
Max. torque (without axial force)	T_{max}	Nm	550														
		in.lb	4868														
Mass moment of inertia (relates to the drive) Clamping hub diameter [mm]	C	14	J_1	kgcm ²	-	-	-	-	-	-	0.21	0.16	0.16	0.2	0.21	0.16	0.16
				10 ⁻³ in.lb.s ²	-	-	-	-	-	-	0.19	0.14	0.14	0.18	0.19	0.14	0.14
	E	19	J_1	kgcm ²	1.5	1.2	1.1	1.0	0.97	1.0	0.57	0.53	0.53	0.57	0.57	0.53	0.53
				10 ⁻³ in.lb.s ²	1.3	1.1	0.97	0.89	0.86	0.89	0.5	0.47	0.47	0.5	0.5	0.47	0.47
	G	24	J_1	kgcm ²	1.6	1.3	1.2	1.1	1.1	1.2	-	-	-	-	-	-	-
				10 ⁻³ in.lb.s ²	1.4	1.2	1.1	0.97	0.97	1.1	-	-	-	-	-	-	-

Please use our sizing software cymex[®] for a detailed sizing – www.wittenstein-cymex.com

^{a)} At max. 10 % F_{2QMax}

^{b)} Valid for standard clamping hub diameter

^{c)} Refers to center of the output shaft or flange

^{d)} Please reduce input speed at higher ambient temperatures

1-stage

up to 19⁴⁾/24 (E⁶⁾/G)
clamping hub diameter

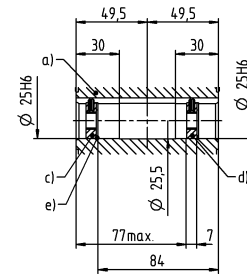
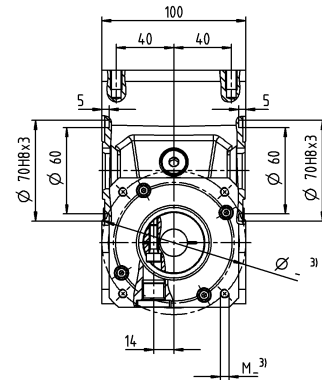
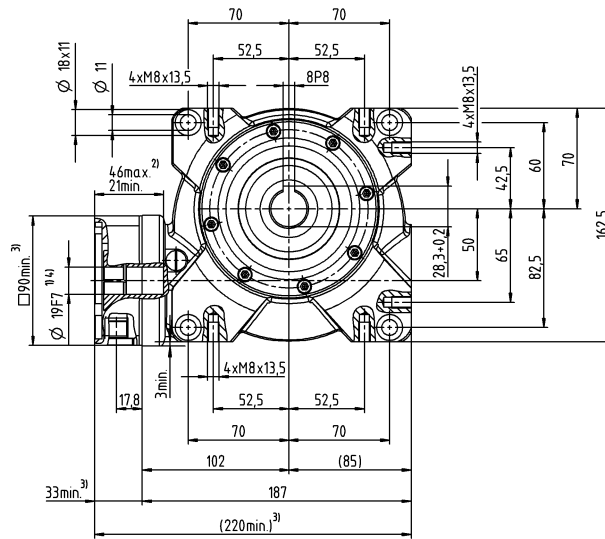

Motor shaft diameter [mm]

2-stage

up to 14/19⁴⁾ (C⁶⁾/E)
clamping hub diameter

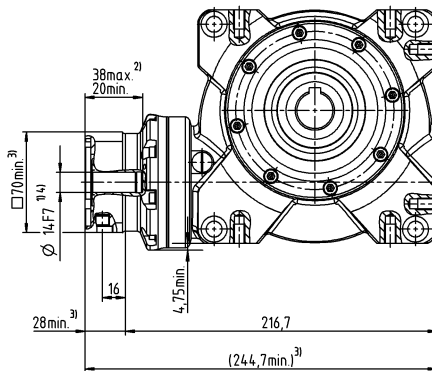

Other output variants

Hollow shaft interfaces on both sides

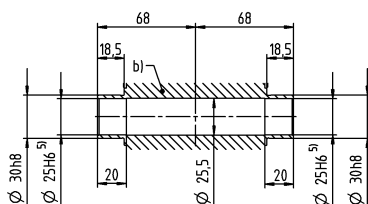

- a) Hollow shaft, keyed on both sides
- b) Hollow shaft interfaces on both sides
- c) End disc for screw M10 (on request)
- d) End disc as forcing washer for screw M12 (on request)
- e) Locking ring – DIN 472 (on request)

See technical data sheet for available clamping hub diameters (mass moment of inertia). Dimensions available on request.

Non-tolerated dimensions are nominal dimensions

- ¹⁾ Check motor shaft fit
- ²⁾ Min./Max. permissible motor shaft length
Longer motor shafts are adaptable, please contact us
- ³⁾ The dimensions depend on the motor
- ⁴⁾ Smaller motor shaft diameter is compensated by a bushing with a minimum wall thickness of 1 mm
- ⁵⁾ Tolerance h6 for mounted shaft
- ⁶⁾ Standard clamping hub diameter

NVH 063 MF 1-/2-stage

			1-stage						2-stage									
Ratio	<i>i</i>		4	7	10	16	28	40	50	70	100	140	200	280	400			
Max. torque ^{a) b)} (at $n_1 = 500$ rpm)	T_{2a}	Nm	250	303	319	331	365	321	319	303	319	365	321	365	321			
		in.lb	2213	2682	2823	2929	3230	2841	2823	2682	2823	3230	2841	3230	2841			
Emergency stop torque ^{a) b)} (permitted 1000 times during the service life of the gearbox)	T_{2Not}	Nm	460	484	491	494	518	447	491	484	494	518	447	518	447			
		in.lb	4071	4283	4345	4372	4584	3956	4345	4283	4372	4584	3956	4584	3956			
Permitted average input speed ^{d)} (at 20 °C ambient temperature)	n_{1N}	rpm	4000						3100									
Max. input speed	n_{1Max}	rpm	4500															
Mean no load running torque ^{b)} (at $n_1 = 3000$ rpm and 20 °C gearbox temperature)	T_{012}	Nm	4.2	3.1	3	2.4	2.3	2.2	1.2	0.7	0.7	1.1	1.1	0.8	0.6			
		in.lb	37.2	27.4	26.6	21.2	20.4	19.5	10.6	6.2	6.2	9.7	9.7	7.1	5.3			
Max. backlash	j_t	arcmin	≤ 6						≤ 7									
Torsional rigidity ^{b)}	C_{t21}	Nm/arcmin	28	28	28	28	28	28	28	28	28	28	28	28	28			
		in.lb/arcmin	248	248	248	248	248	248	248	248	248	248	248	248	248			
Max. axial force ^{c)}	F_{2AMax}	N	8250															
		lb _f	1856															
Max. lateral force ^{b)}	F_{2OMax}	N	6000															
		lb _f	1350															
Max. tilting moment	M_{2KMax}	Nm	843															
		in.lb	7461															
Efficiency at full load (at $n_1 = 500$ rpm)	η	%	93	91	88	83	74	68	86	89	86	72	66	72	66			
Service life	L_n	h	> 20000															
Weight (incl. standard adapter plate)	m	kg	13						13.7									
		lb _m	28.7						30									
Operating noise (at reference ratio and reference speed – ratio-specific values available in cymex [®])	L_{PA}	dB(A)	≤ 64															
Max. permitted housing temperature		°C	+90															
		°F	+194															
Ambient temperature		°C	-15 to +40															
		°F	+5 to +104															
Lubrication			Lubricated for life															
Direction of rotation			See drawing															
Protection class			IP 65															
Shrink disc (Standard Version)			SD 036x072 S2V															
Max. torque (without axial force)	T_{max}	Nm	640															
		in.lb	5664															
Mass moment of inertia (relates to the drive) Clamping hub diameter [mm]	E	19	J_1	kgcm ²	-	-	-	-	-	-	0.75	0.59	0.58	0.75	0.75	0.58	0.58	
				10 ⁻³ in.lb.s ²	-	-	-	-	-	-	0.66	0.52	0.51	0.66	0.66	0.51	0.51	
	G	24	J_1	kgcm ²	-	-	-	-	-	-	2.3	2.2	2.2	2.3	2.3	2.2	2.2	2.2
				10 ⁻³ in.lb.s ²	-	-	-	-	-	-	2.0	1.9	1.9	2.0	2.0	1.9	1.9	
	H	28	J_1	kgcm ²	4.9	4.0	3.8	3.7	3.6	3.6	-	-	-	-	-	-	-	-
				10 ⁻³ in.lb.s ²	4.3	3.5	3.4	3.3	3.2	3.2	-	-	-	-	-	-	-	-

Please use our sizing software cymex[®] for a detailed sizing – www.wittenstein-cymex.com

^{a)} At max. 10 % F_{2OMax}

^{b)} Valid for standard clamping hub diameter

^{c)} Refers to center of the output shaft or flange

^{d)} Please reduce input speed at higher ambient temperatures

1-stage

up to 28⁴⁾ (H)⁶⁾
clamping hub diameter

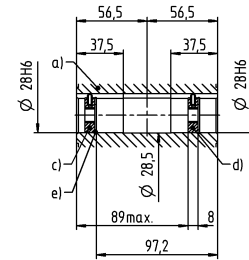
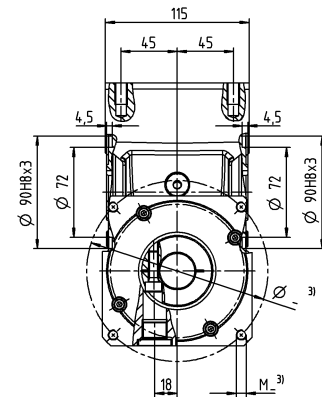
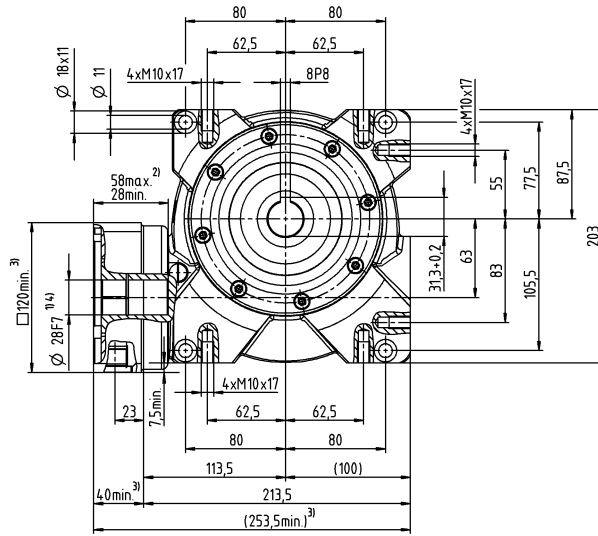

Motor shaft diameter [mm]

2-stage

up to 19/24⁴⁾ (E⁶⁾/G)⁶⁾
clamping hub diameter

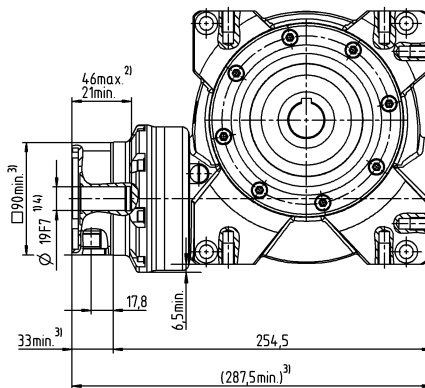

Other output variants

Hollow shaft interfaces on both sides

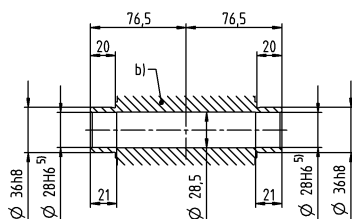

- a) Hollow shaft, keyed on both sides
- b) Hollow shaft interfaces on both sides
- c) End disc for screw M10 (on request)
- d) End disc as forcing washer for screw M12 (on request)
- e) Locking ring – DIN 472 (on request)

See technical data sheet for available clamping hub diameters (mass moment of inertia). Dimensions available on request.

Non-tolerated dimensions are nominal dimensions

- ¹⁾ Check motor shaft fit
- ²⁾ Min. /Max. permissible motor shaft length
Longer motor shafts are adaptable, please contact us
- ³⁾ The dimensions depend on the motor
- ⁴⁾ Smaller motor shaft diameter is compensated by a bushing with a minimum wall thickness of 1 mm
- ⁵⁾ Tolerance h6 for mounted shaft
- ⁶⁾ Standard clamping hub diameter

NVS 040 MF 1-/2-stage

			1-stage						2-stage								
Ratio	<i>i</i>		4	7	10	16	28	40	50	70	100	140	200	280	400		
Max. torque ^{a) b) e)} (at $n_1 = 500$ rpm)	T_{2a}	Nm	63	73	87	89	96	84	91	82	91	98	91	98	91		
		in.lb	558	646	770	788	850	743	805	726	805	867	805	867	805		
Emergency stop torque ^{a) b) e)} (permitted 1000 times during the service life of the gearbox)	T_{2Not}	Nm	118	126	125	129	134	122	125	126	125	134	122	134	122		
		in.lb	1044	1115	1106	1142	1186	1080	1106	1115	1106	1186	1080	1186	1080		
Permitted average input speed ^{d)} (at 20 °C ambient temperature)	n_{1N}	rpm	4000						4400								
Max. input speed	n_{1Max}	rpm	6000														
Mean no load running torque ^{b)} (at $n_1 = 3000$ rpm and 20 °C gearbox temperature)	T_{012}	Nm	0.8	0.7	0.6	0.5	0.4	0.4	0.4	0.2	0.2	0.4	0.4	0.3	0.2		
		in.lb	7.1	6.2	5.3	4.4	3.5	3.5	3.5	1.8	1.8	3.5	3.5	2.7	1.8		
Max. backlash	j_t	arcmin	≤ 6						≤ 7								
Torsional rigidity ^{b)}	C_{t21}	Nm/arcmin	4.5	4.5	4.5	4.5	4.5	4.5	4.5	4.5	4.5	4.5	4.5	4.5	4.5		
		in.lb/arcmin	40	40	40	40	40	40	40	40	40	40	40	40	40		
Max. axial force ^{c)}	F_{2AMax}	N	3000														
		lb _f	675														
Max. lateral force ^{b)}	F_{2OMax}	N	2400														
		lb _f	540														
Max. tilting moment	M_{2KMax}	Nm	205														
		in.lb	1814														
Efficiency at full load (at $n_1 = 500$ rpm)	η	%	93	90	88	82	73	67	86	88	86	71	65	71	65		
Service life	L_n	h	> 20000														
Weight (incl. standard adapter plate)	m	kg	5						5.6								
		lb _m	11.1						12								
Operating noise (at reference ratio and reference speed – ratio-specific values available in cymex [®])	L_{PA}	dB(A)	≤ 54						≤ 58								
Max. permitted housing temperature		°C	+90														
		°F	+194														
Ambient temperature		°C	-15 to +40														
		°F	+5 to +104														
Lubrication			Lubricated for life														
Direction of rotation			See drawing														
Protection class			IP 65														
Elastomer coupling (recommended product type – validate sizing with cymex [®])			ELC-00060B-016.000-X														
Bore diameter of coupling on the application side		mm	X = 016.000 - 032.000														
Mass moment of inertia (relates to the drive)	C	14	J_1	kgcm ²	0.56	0.42	0.39	0.37	0.36	0.35	0.16	0.15	0.15	0.16	0.16	0.15	0.15
				10 ⁻³ in.lb.s ²	0.5	0.37	0.35	0.33	0.32	0.31	0.14	0.13	0.13	0.14	0.14	0.13	0.13
Clamping hub diameter [mm]	E	19	J_1	kgcm ²	0.88	0.74	0.7	0.68	0.68	0.67	0.53	0.52	0.52	0.53	0.53	0.52	0.52
				10 ⁻³ in.lb.s ²	0.78	0.65	0.62	0.6	0.6	0.59	0.47	0.46	0.46	0.47	0.47	0.46	0.46

Please use our sizing software cymex[®] for a detailed sizing – www.wittenstein-cymex.com

- ^{a)} At max. 10 % F_{2OMax}
- ^{b)} Valid for standard clamping hub diameter
- ^{c)} Refers to center of the output shaft or flange
- ^{d)} Please reduce input speed at higher ambient temperatures
- ^{e)} Valid for: Smooth shaft

1-stage

up to 14/19⁴⁾ (C⁶⁾/E)
clamping hub diameter

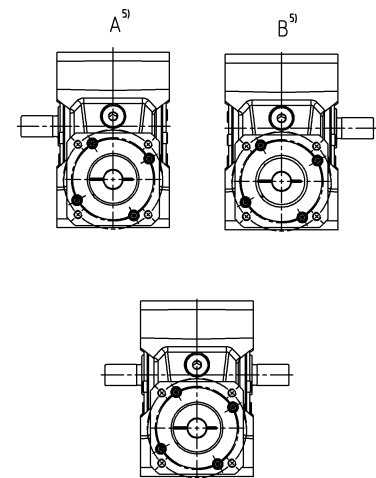
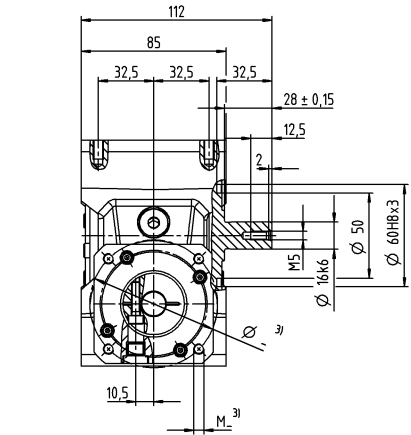
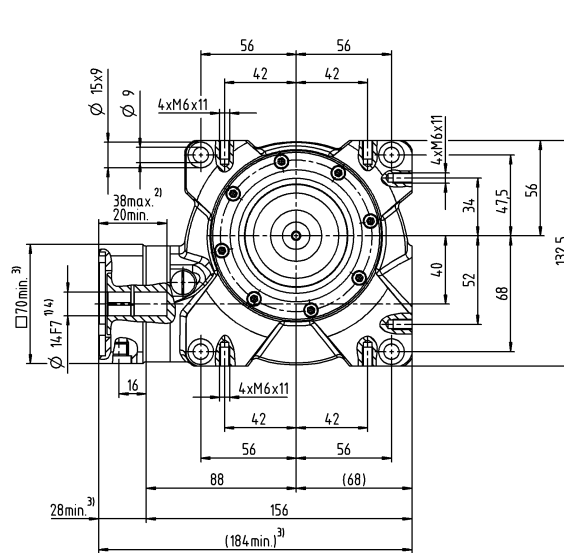

Optional dual-shaft output. Drawings available on request.
Involute gearing is not possible.

Motor shaft diameter [mm]

2-stage

up to 14/19⁴⁾ (C⁶⁾/E)
clamping hub diameter

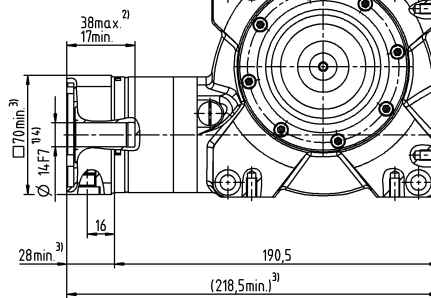

Other output variants

Shaft with key

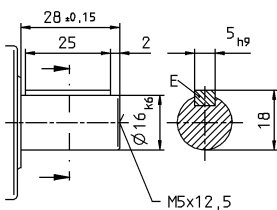

See technical data sheet for available clamping hub diameters (mass moment of inertia). Dimensions available on request.

Non-tolerated dimensions are nominal dimensions

¹⁾ Check motor shaft fit

²⁾ Min. / Max. permissible motor shaft length

Longer motor shafts are adaptable, please contact us

³⁾ The dimensions depend on the motor

⁴⁾ Smaller motor shaft diameter is compensated by a

bushing with a minimum wall thickness of 1 mm

⁵⁾ Output side

⁶⁾ Standard clamping hub diameter

NVS 050 MF 1-/2-stage

			1-stage						2-stage								
Ratio	i		4	7	10	16	28	40	50	70	100	140	200	280	400		
Max. torque ^{a) b) e)} (at $n_1 = 500$ rpm)	T_{2a}	Nm	130	150	153	157	167	141	153	150	153	167	141	167	141		
		in.lb	1151	1328	1354	1389	1478	1248	1354	1328	1354	1478	1248	1478	1248		
Emergency stop torque ^{a) b) e)} (permitted 1000 times during the service life of the gearbox)	T_{2Not}	Nm	230	242	242	250	262	236	242	242	242	262	236	262	236		
		in.lb	2036	2142	2142	2213	2319	2089	2142	2142	2142	2319	2089	2319	2089		
Permitted average input speed ^{d)} (at 20 °C ambient temperature)	n_{1N}	rpm	4000						3500								
Max. input speed	n_{1Max}	rpm	6000														
Mean no load running torque ^{b)} (at $n_1 = 3000$ rpm and 20 °C gearbox temperature)	T_{012}	Nm	2.3	2.2	1.6	1.5	1.2	1.1	0.7	0.5	0.4	0.6	0.6	0.4	0.4		
		in.lb	20.4	19.5	14.2	13.3	10.6	9.7	6.2	4.4	3.5	5.3	5.3	3.5	3.5		
Max. backlash	j_t	arcmin	≤ 6						≤ 7								
Torsional rigidity ^{b)}	C_{t21}	Nm/arcmin	8	8	8	8	8	8	8	8	8	8	8	8	8		
		in.lb/arcmin	71	71	71	71	71	71	71	71	71	71	71	71	71		
Max. axial force ^{c)}	F_{2AMax}	N	5000														
		lb _f	1125														
Max. lateral force ^{b)}	F_{2QMMax}	N	3800														
		lb _f	855														
Max. tilting moment	M_{2KMMax}	Nm	409														
		in.lb	3620														
Efficiency at full load (at $n_1 = 500$ rpm)	η	%	92	89	86	82	72	64	84	87	84	70	62	70	62		
Service life	L_n	h	> 20000														
Weight (incl. standard adapter plate)	m	kg	8						8.7								
		lb _m	17.7						19								
Operating noise (at reference ratio and reference speed – ratio-specific values available in cymex [®])	L_{PA}	dB(A)	≤ 62														
Max. permitted housing temperature		°C	+90														
		°F	+194														
Ambient temperature		°C	-15 to +40														
		°F	+5 to +104														
Lubrication			Lubricated for life														
Direction of rotation			See drawing														
Protection class			IP 65														
Elastomer coupling (recommended product type – validate sizing with cymex [®])			ELC-00150B-022.000-X														
Bore diameter of coupling on the application side		mm	X = 022.000 - 036.000														
Mass moment of inertia (relates to the drive) Clamping hub diameter [mm]	C	14	J_1	kgcm ²	-	-	-	-	-	-	0.21	0.16	0.16	0.2	0.21	0.16	0.16
				10 ⁻³ in.lb.s ²	-	-	-	-	-	-	0.19	0.14	0.14	0.18	0.19	0.14	0.14
	E	19	J_1	kgcm ²	1.5	1.2	1.1	1.0	0.97	1.0	0.57	0.53	0.53	0.57	0.57	0.53	0.53
				10 ⁻³ in.lb.s ²	1.3	1.1	0.97	0.89	0.86	0.89	0.5	0.47	0.47	0.5	0.5	0.47	0.47
G	24	J_1	kgcm ²	1.6	1.3	1.2	1.1	1.1	1.2	-	-	-	-	-	-	-	
			10 ⁻³ in.lb.s ²	1.4	1.2	1.1	0.97	0.97	1.1	-	-	-	-	-	-	-	

Please use our sizing software cymex[®] for a detailed sizing – www.wittenstein-cymex.com

^{a)} At max. 10 % F_{2QMMax}

^{b)} Valid for standard clamping hub diameter

^{c)} Refers to center of the output shaft or flange

^{d)} Please reduce input speed at higher ambient temperatures

^{e)} Valid for: Smooth shaft

1-stage

up to 19⁴⁾/24 (E⁶⁾/G)
clamping hub
diameter

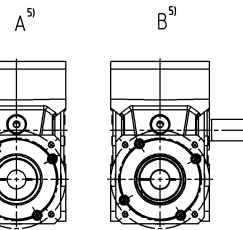
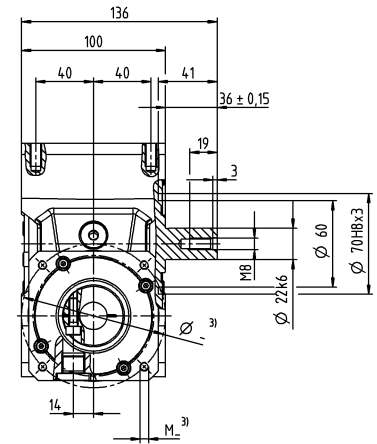
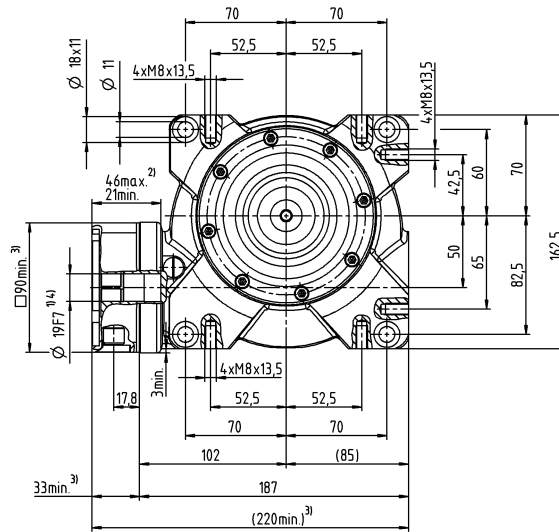

2-stage

up to 14/19⁴⁾ (C⁶⁾/E)
clamping hub
diameter

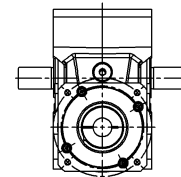
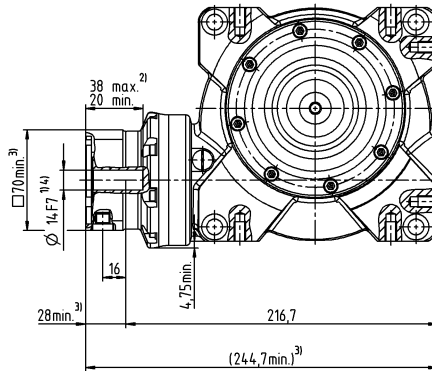

Motor shaft diameter [mm]

Optional dual-shaft output. Drawings available on request.
Involute gearing is not possible.

Worm Gearboxes
Value Line

Other output variants

Shaft with key

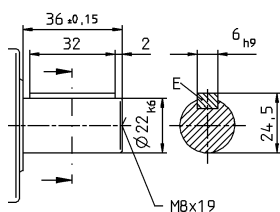

See technical data sheet for available clamping hub diameters
(mass moment of inertia). Dimensions available on request.

Non-tolerated dimensions are nominal dimensions

- ¹⁾ Check motor shaft fit
- ²⁾ Min./Max. permissible motor shaft length
Longer motor shafts are adaptable, please contact us
- ³⁾ The dimensions depend on the motor
- ⁴⁾ Smaller motor shaft diameter is compensated by a
bushing with a minimum wall thickness of 1 mm
- ⁵⁾ Output side
- ⁶⁾ Standard clamping hub diameter

NVS 063 MF 1-/2-stage

			1-stage						2-stage								
Ratio	i		4	7	10	16	28	40	50	70	100	140	200	280	400		
Max. torque ^{a) b) e)} (at $n_1 = 500$ rpm)	T_{2a}	Nm	250	303	319	331	365	321	319	303	319	365	321	365	321		
		in.lb	2213	2682	2823	2929	3230	2841	2823	2682	2823	3230	2841	3230	2841		
Emergency stop torque ^{a) b) e)} (permitted 1000 times during the service life of the gearbox)	T_{2Not}	Nm	460	484	491	494	518	447	491	484	494	518	447	518	447		
		in.lb	4071	4283	4345	4372	4584	3956	4345	4283	4372	4584	3956	4584	3956		
Permitted average input speed ^{d)} (at 20 °C ambient temperature)	n_{1N}	rpm	4000						3100								
Max. input speed	n_{1Max}	rpm	4500														
Mean no load running torque ^{b)} (at $n_1 = 3000$ rpm and 20 °C gearbox temperature)	T_{012}	Nm	4.2	3.1	3	2.4	2.3	2.2	1.2	0.7	0.7	1.1	1.1	0.8	0.6		
		in.lb	37.2	27.4	26.6	21.2	20.4	19.5	10.6	6.2	6.2	9.7	9.7	7.1	5.3		
Max. backlash	j_t	arcmin	≤ 6						≤ 7								
Torsional rigidity ^{b)}	C_{t21}	Nm/arcmin	28	28	28	28	28	28	28	28	28	28	28	28	28		
		in.lb/arcmin	248	248	248	248	248	248	248	248	248	248	248	248	248		
Max. axial force ^{c)}	F_{2AMax}	N	8250														
		lb _f	1856														
Max. lateral force ^{b)}	F_{2OMax}	N	6000														
		lb _f	1350														
Max. tilting moment	M_{2KMax}	Nm	843														
		in.lb	7461														
Efficiency at full load (at $n_1 = 500$ rpm)	η	%	93	91	88	83	74	68	86	89	86	72	66	72	66		
Service life	L_n	h	> 20000														
Weight (incl. standard adapter plate)	m	kg	13						13.7								
		lb _m	28.7						30								
Operating noise (at reference ratio and reference speed – ratio-specific values available in cymex [®])	L_{PA}	dB(A)	≤ 64														
Max. permitted housing temperature		°C	+90														
		°F	+194														
Ambient temperature		°C	-15 to +40														
		°F	+5 to +104														
Lubrication			Lubricated for life														
Direction of rotation			See drawing														
Protection class			IP 65														
Elastomer coupling (recommended product type – validate sizing with cymex [®])			ELC-00300B-032.000-X														
Bore diameter of coupling on the application side		mm	X = 032.000 - 045.000														
Mass moment of inertia (relates to the drive) Clamping hub diameter [mm]	E	19	J_1	kgcm ²	-	-	-	-	-	-	0.75	0.59	0.58	0.75	0.75	0.58	0.58
				10 ⁻³ in.lb.s ²	-	-	-	-	-	-	0.66	0.52	0.51	0.66	0.66	0.51	0.51
	G	24	J_1	kgcm ²	-	-	-	-	-	-	2.3	2.2	2.2	2.3	2.3	2.2	2.2
				10 ⁻³ in.lb.s ²	-	-	-	-	-	-	2.0	1.9	1.9	2.0	2.0	1.9	1.9
H	28	J_1	kgcm ²	4.9	4.0	3.8	3.7	3.6	3.6	-	-	-	-	-	-		
			10 ⁻³ in.lb.s ²	4.3	3.5	3.4	3.3	3.2	3.2	-	-	-	-	-	-		

Please use our sizing software cymex[®] for a detailed sizing – www.wittenstein-cymex.com

- ^{a)} At max. 10 % F_{2OMax}
- ^{b)} Valid for standard clamping hub diameter
- ^{c)} Refers to center of the output shaft or flange
- ^{d)} Please reduce input speed at higher ambient temperatures
- ^{e)} Valid for: Smooth shaft

1-stage

up to 28⁴⁾ (H)⁶⁾
clamping hub
diameter

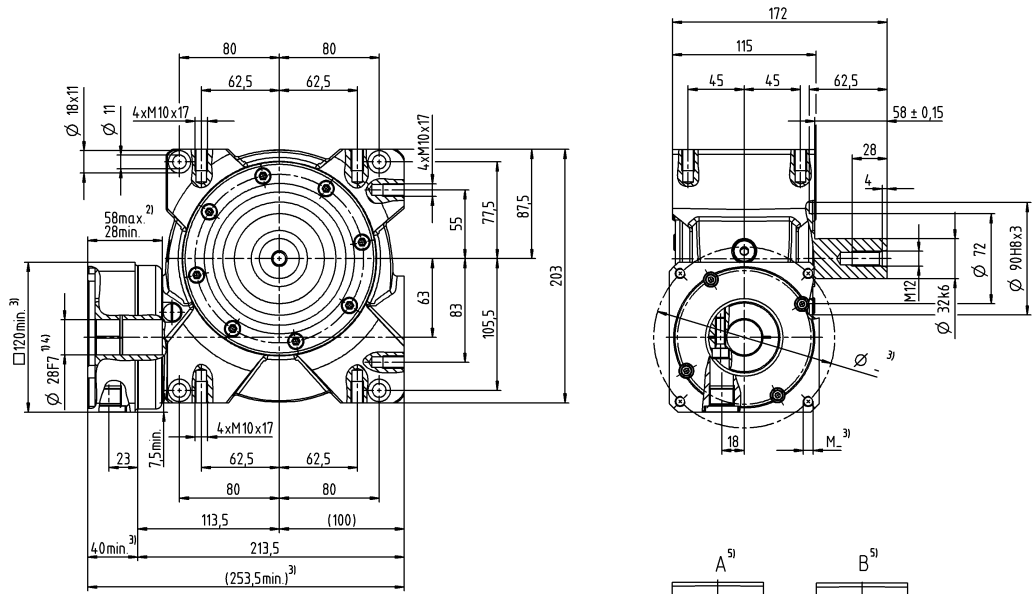

2-stage

up to 19/24⁴⁾ (E⁶⁾/G)
clamping hub
diameter

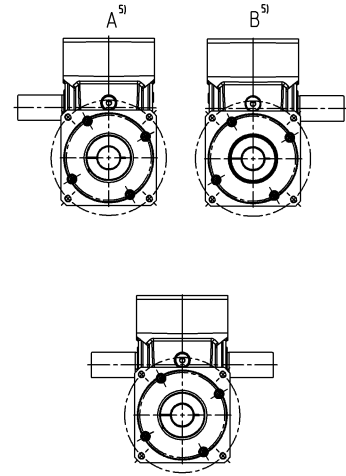
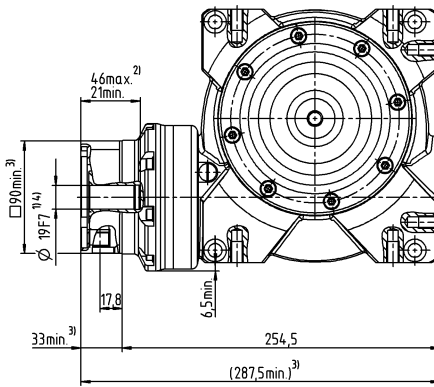

Motor shaft diameter [mm]

Optional dual-shaft output. Drawings available on request.
Involute gearing is not possible.

Other output variants

Shaft with key

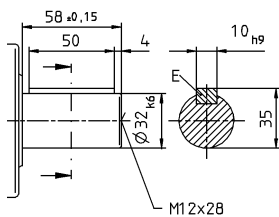

See technical data sheet for available clamping hub diameters (mass moment of inertia). Dimensions available on request.

Non-tolerated dimensions are nominal dimensions

¹⁾ Check motor shaft fit

²⁾ Min. / Max. permissible motor shaft length

Longer motor shafts are adaptable, please contact us

³⁾ The dimensions depend on the motor

⁴⁾ Smaller motor shaft diameter is compensated by a

bushing with a minimum wall thickness of 1 mm

⁵⁾ Output side

⁶⁾ Standard clamping hub diameter

Application-specific solutions

HYGIENIC DESIGN HDV

Our Hygienic Design products are specially developed for unusual fields of application in food processing. They are made with highly resistant stainless steel and ideally suited for cleaning with aggressive cleaning agents and disinfectants. Direct process integration allows new design freedom and an open machine concept without encasings.

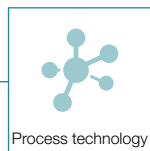
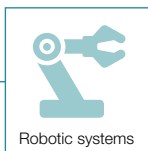

AREAS OF APPLICATION

Application-specific solutions

HDV – Reliably Clean



HDV

Aseptic, highly dynamic and outstanding positioning accuracy – the HDV was developed in accordance with EHEDG guidelines and meets the strict hygiene requirements of production and packaging facilities. The gearbox in hygienic design not only offers you maximum safety against contamination-related product and process risks, but also guarantees maximum plant availability and productivity of the equipment.

PRODUCT HIGHLIGHTS



New design freedom

Direct process integration opens up new design options.



Resistance

Resistant against chemical cleaning agents and disinfectants.



Cleaning

Fast, efficient, and safe cleaning, also suitable for CIP processes.



Max. achievable impermeability

IP69X (max. 30 bar).
Relating to DIN 60529:2014-09



Pharmaceuticals – bottling plant for liquid pharmaceutical products



Cosmetics – bottling plant for creams



More information about the HDV: simply scan the QR code using your smartphone. www.wittenstein.de/en-en/hygienic-design



- A Certification**
- FDA certified
 - NSF certified

- B Surface texture**
- Smooth-rolled surface made of hygienic steel 1.4404
 - Electropolished surface also optionally possible

- C Cavity-free housing design**
- No undercuts
 - Large radii
 - No horizontal surfaces

- D Maximum safety**
- Triple sealing concept
 - Seals resistant to cleaning agents
 - IP69X (max. 30 bar)

- E Available output types**
- Smooth shaft
 - Shaft with key



Sweet goods – packaging plant for cookies

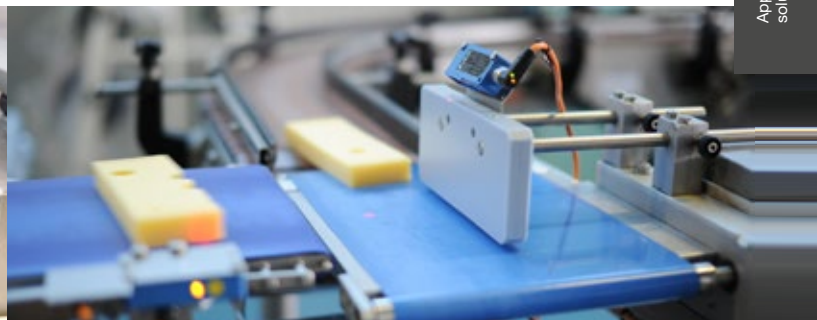

Milk products – cheese processing plant

HDV 015 MF 1-/2-stage

			1-stage				2-stage							
Ratio	i		4	5	7	10	16	20	25	35	50	70	100	
Max. torque ^{a) b) e)}	T_{2a}	Nm	51	51	51	46	51	51	51	51	51	51	46	
		in.lb	451	451	451	407	451	451	451	451	451	451	407	
Max. acceleration torque ^{e)} (max. 1000 cycles per hour)	T_{2B}	Nm	32	32	32	29	32	32	32	32	32	32	29	
		in.lb	283	283	283	257	283	283	283	283	283	283	257	
Emergency stop torque ^{a) b) e)} (permitted 1000 times during the service life of the gearbox)	T_{2Not}	Nm	75	75	75	75	75	75	75	75	75	75	75	
		in.lb	664	664	664	664	664	664	664	664	664	664	664	
Permitted average input speed ^{d)} (at T_{2N} and 20 °C ambient temperature)	n_{1N}	rpm	3000	3000	3000	3000	3700	3700	3700	3700	3700	3700	3700	
Max. input speed	n_{1Max}	rpm	6000	6000	6000	6000	6000	6000	6000	6000	6000	6000	6000	
Mean no load running torque ^{b)} (at $n_1=3000$ rpm and 20 °C gearbox temperature)	T_{012}	Nm	0.15	0.15	0.15	0.15	0.15	0.15	0.15	0.15	0.15	0.15	0.15	
		in.lb	1.3	1.3	1.3	1.3	1.3	1.3	1.3	1.3	1.3	1.3	1.3	
Max. backlash	j_t	arcmin	≤ 10				≤ 15							
Torsional rigidity ^{b)}	C_{t21}	Nm/arcmin	2.3	2.3	2.3	2	2.3	2.3	2.3	2.3	2.3	2.3	2	
		in.lb/arcmin	20	20	20	18	20	20	20	20	20	20	18	
Max. axial force ^{c)} (Standard / HIGH FORCES)	F_{2AMax}	N	500 / 1000				500 / 1000							
		lb _f	113 / 225				113 / 225							
Max. lateral force ^{c)} (Standard / HIGH FORCES)	F_{2QMax}	N	350 / 1600				350 / 1600							
		lb _f	79 / 360				79 / 360							
Max. tilting moment (Standard / HIGH FORCES)	M_{2KMax}	Nm	20 / 105				20 / 105							
		in.lb	177 / 929				177 / 929							
Efficiency at full load	η	%	97				95							
Service life	L_n	h	> 20000				> 20000							
Weight (incl. standard adapter plate)	m	kg	3.2				3.8							
		lb _m	7.1				8.4							
Operating noise (at reference ratio and reference speed – ratio-specific values available in cymex®)	L_{pA}	dB(A)	≤ 60				≤ 60							
Max. permitted housing temperature		°C	+90				+90							
		°F	+194				+194							
Ambient temperature		°C	-25 to +40				-25 to +40							
		°F	-13 to +104				-13 to +104							
Lubrication			Lubricated for life											
Direction of rotation			In- and output same direction											
Protection class ^{g)}			IP69K (max. 30 bar)											
Elastomer coupling (recommended product type – validate sizing with cymex®)			-											
Bore diameter of coupling on the application side		mm	-											
Mass moment of inertia (relates to the drive) Clamping hub diameter [mm]	C	14	J_1	kgcm ²	0.18	0.17	0.15	0.15	0.17	0.16	0.16	0.15	0.15	0.15
				10 ⁻³ in.lb.s ²	0.16	0.15	0.13	0.13	0.15	0.14	0.14	0.13	0.13	0.13

Please use our sizing software cymex® for a detailed sizing – www.wittenstein-cymex.com

^{a)} Valid for torque transmission only

^{b)} Valid for standard clamping hub diameter

^{c)} Refers to center of the output shaft or flange

^{d)} Please reduce input speed at higher ambient temperatures

^{e)} Valid for: Smooth shaft

^{g)} Applies at standstill, for details see operating instructions

1-stage

up to 14⁴⁾ (C)⁵⁾
clamping hub
diameter

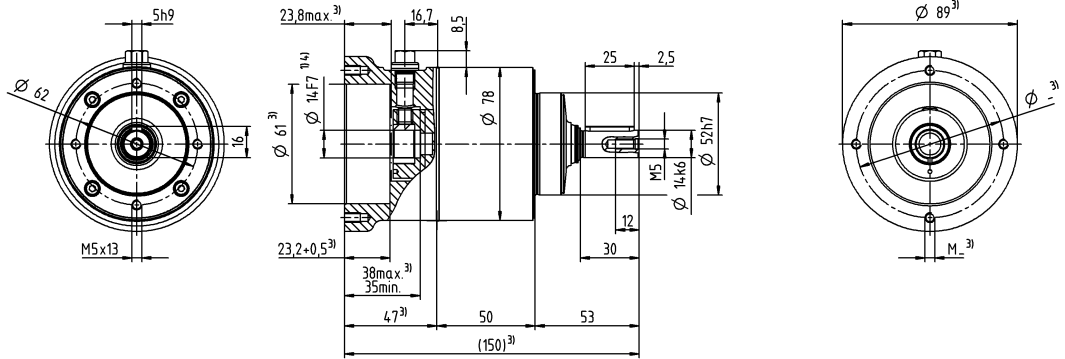

2-stage

up to 14⁴⁾ (C)⁵⁾
clamping hub
diameter

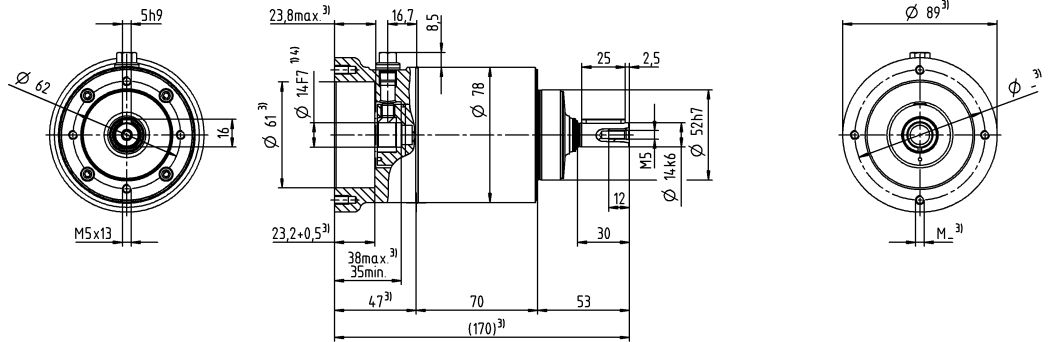

Motor shaft diameter [mm]

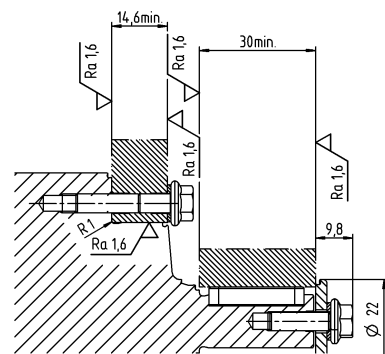

Other output variants

Smooth shaft

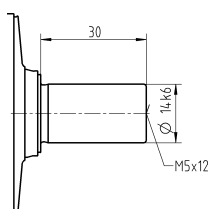

Mounting accessories:

Mounting kit comprising stainless steel screws, washers, seals and O-rings available as an option.

Non-tolerated dimensions are nominal dimensions

¹⁾ Check motor shaft fit

²⁾ Min. / Max. permissible motor shaft length

Longer motor shafts are possible, please contact alpha

³⁾ The dimensions depend on the motor

⁴⁾ Smaller motor shaft diameter is compensated by a bushing with a minimum wall thickness of 1 mm

⁵⁾ Standard clamping hub diameter

HDV 025 MF 1-/2-stage

			1-stage				2-stage								
Ratio	i		4	5	7	10	16	20	25	35	50	70	100		
Max. torque ^{a) b) e)}	T_{2a}	Nm	128	128	128	115	128	128	128	128	128	128	115		
		in.lb	1133	1133	1133	1018	1133	1133	1133	1133	1133	1133	1018		
Max. acceleration torque ^{e)} (max. 1000 cycles per hour)	T_{2B}	Nm	80	80	80	72	80	80	80	80	80	80	72		
		in.lb	708	708	708	637	708	708	708	708	708	708	637		
Emergency stop torque ^{a) b) e)} (permitted 1000 times during the service life of the gearbox)	T_{2Not}	Nm	190	190	190	190	190	190	190	190	190	190	190		
		in.lb	1682	1682	1682	1682	1682	1682	1682	1682	1682	1682	1682		
Permitted average input speed ^{d)} (at T_{2N} and 20 °C ambient temperature)	n_{1N}	rpm	2700	2700	2700	2700	3400	3400	3400	3400	3400	3400	3400		
Max. input speed	n_{1Max}	rpm	6000	6000	6000	6000	6000	6000	6000	6000	6000	6000	6000		
Mean no load running torque ^{b)} (at $n_1=3000$ rpm and 20 °C gearbox temperature)	T_{012}	Nm	0.3	0.3	0.3	0.3	0.3	0.3	0.3	0.3	0.3	0.3	0.3		
		in.lb	2.7	2.7	2.7	2.7	2.7	2.7	2.7	2.7	2.7	2.7	2.7		
Max. backlash	j_t	arcmin	≤ 10				≤ 15								
Torsional rigidity ^{b)}	C_{t21}	Nm/arcmin	7.5	7.5	7.5	5.5	7.5	7.5	7.5	7.5	7.5	7.5	7.5	5.5	
		in.lb/arcmin	66	66	66	49	66	66	66	66	66	66	66	49	
Max. axial force ^{c)} (Standard / HIGH FORCES)	F_{2AMax}	N	500 / 1500				500 / 1500								
		lb _f	113 / 338				113 / 338								
Max. lateral force ^{c)} (Standard / HIGH FORCES)	F_{2QMMax}	N	500 / 2500				500 / 2500								
		lb _f	113 / 563				113 / 563								
Max. tilting moment (Standard / HIGH FORCES)	M_{2KMMax}	Nm	31 / 185				31 / 185								
		in.lb	274 / 1637				274 / 1637								
Efficiency at full load	η	%	97				95								
Service life	L_n	h	> 20000				> 20000								
Weight (incl. standard adapter plate)	m	kg	5.2				6.5								
		lb _m	11				14								
Operating noise (at reference ratio and reference speed – ratio-specific values available in cymex®)	L_{pA}	dB(A)	≤ 63				≤ 63								
Max. permitted housing temperature		°C	+90				+90								
		°F	+194				+194								
Ambient temperature		°C	-25 to +40				-25 to +40								
		°F	-13 to +104				-13 to +104								
Lubrication			Lubricated for life												
Direction of rotation			In- and output same direction												
Protection class ^{g)}			IP69K (max. 30 bar)												
Elastomer coupling (recommended product type – validate sizing with cymex®)			-												
Bore diameter of coupling on the application side		mm	-												
Mass moment of inertia (relates to the drive) Clamping hub diameter [mm]	E	19	J_1	kgcm ²	0.63	0.54	0.52	0.46	0.6	0.52	0.54	0.5	0.52	0.52	0.46
				10 ⁻³ in.lb.s ²	0.56	0.48	0.46	0.41	0.53	0.46	0.48	0.44	0.46	0.46	0.41

Please use our sizing software cymex® for a detailed sizing – www.wittenstein-cymex.com

^{a)} Valid for torque transmission only

^{b)} Valid for standard clamping hub diameter

^{c)} Refers to center of the output shaft or flange

^{d)} Please reduce input speed at higher ambient temperatures

^{e)} Valid for: Smooth shaft

^{g)} Applies at standstill, for details see operating instructions

1-stage

up to 19⁴⁾ (E⁵⁾
clamping hub diameter

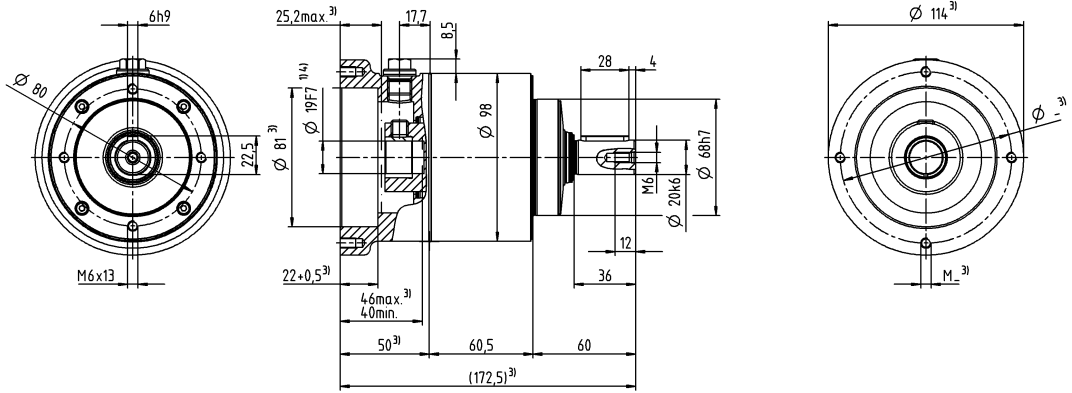

2-stage

up to 19⁴⁾ (E⁵⁾
clamping hub diameter

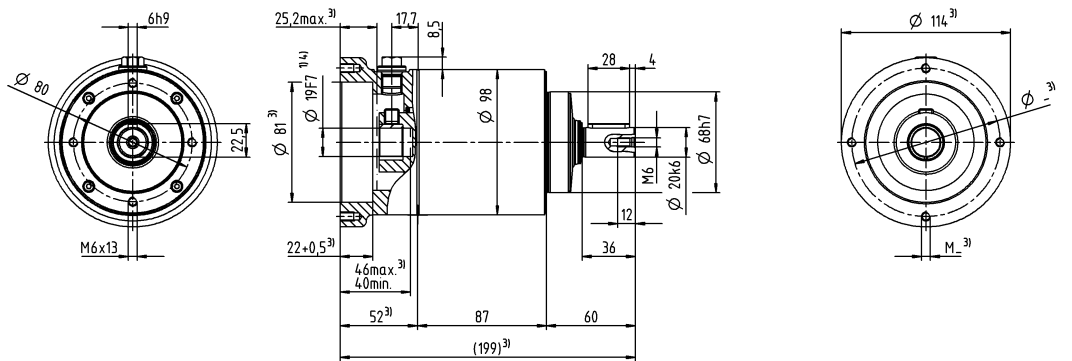

Motor shaft diameter [mm]

Other output variants

Smooth shaft

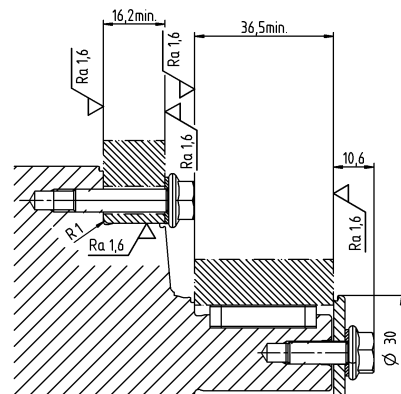
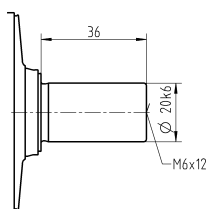

Mounting accessories:
Mounting kit comprising stainless steel screws, washers, seals and O-rings available as an option.

- Non-tolerated dimensions are nominal dimensions
- ¹⁾ Check motor shaft fit
- ²⁾ Min. / Max. permissible motor shaft length
Longer motor shafts are possible, please contact alpha
- ³⁾ The dimensions depend on the motor
- ⁴⁾ Smaller motor shaft diameter is compensated by a bushing with a minimum wall thickness of 1 mm
- ⁵⁾ Standard clamping hub diameter

Application-specific solutions

HDV 035 MF 1-/2-stage

			1-stage				2-stage								
Ratio	i		4	5	7	10	16	20	25	35	50	70	100		
Max. torque ^{a) b) e)}	T_{2a}	Nm	320	320	320	288	320	320	320	320	320	320	288		
		in.lb	2832	2832	2832	2549	2832	2832	2832	2832	2832	2832	2832	2549	
Max. acceleration torque ^{e)} (max. 1000 cycles per hour)	T_{2B}	Nm	200	200	200	180	200	200	200	200	200	200	180		
		in.lb	1770	1770	1770	1593	1770	1770	1770	1770	1770	1770	1593		
Emergency stop torque ^{a) b) e)} (permitted 1000 times during the service life of the gearbox)	T_{2Not}	Nm	480	480	480	480	480	480	480	480	480	480	480		
		in.lb	4248	4248	4248	4248	4248	4248	4248	4248	4248	4248	4248		
Permitted average input speed ^{d)} (at T_{2N} and 20 °C ambient temperature)	n_{1N}	rpm	2000	2000	2000	2000	2600	2600	2600	2600	2600	2600	2600		
Max. input speed	n_{1Max}	rpm	4800	4800	4800	4800	4800	4800	4800	4800	4800	4800	4800		
Mean no load running torque ^{b)} (at $n_1=3000$ rpm and 20 °C gearbox temperature)	T_{012}	Nm	0.5	0.5	0.5	0.5	0.5	0.5	0.5	0.5	0.5	0.5	0.5		
		in.lb	4.4	4.4	4.4	4.4	4.4	4.4	4.4	4.4	4.4	4.4	4.4		
Max. backlash	j_t	arcmin	≤ 10				≤ 15								
Torsional rigidity ^{b)}	C_{t21}	Nm/arcmin	24	24	24	22	24	24	24	24	24	24	22		
		in.lb/arcmin	212	212	212	195	212	212	212	212	212	212	195		
Max. axial force ^{c)} (Standard / HIGH FORCES)	F_{2AMax}	N	1700 / 3000				1700 / 3000								
		lb _f	383 / 675				383 / 675								
Max. lateral force ^{c)} (Standard / HIGH FORCES)	F_{2QMax}	N	1200 / 4250				1200 / 4250								
		lb _f	270 / 956				270 / 956								
Max. tilting moment (Standard / HIGH FORCES)	M_{2KMax}	Nm	95 / 407				95 / 407								
		in.lb	841 / 3602				841 / 3602								
Efficiency at full load	η	%	97				95								
Service life	L_n	h	> 20000				> 20000								
Weight (incl. standard adapter plate)	m	kg	13.6				16.6								
		lb _m	30				37								
Operating noise (at reference ratio and reference speed – ratio-specific values available in cymex®)	L_{pA}	dB(A)	≤ 68				≤ 68								
Max. permitted housing temperature		°C	+90				+90								
		°F	+194				+194								
Ambient temperature		°C	-25 to +40				-25 to +40								
		°F	-13 to +104				-13 to +104								
Lubrication			Lubricated for life												
Direction of rotation			In- and output same direction												
Protection class ^{g)}			IP69K (max. 30 bar)												
Elastomer coupling (recommended product type – validate sizing with cymex®)			-												
Bore diameter of coupling on the application side		mm	-												
Mass moment of inertia (relates to the drive) Clamping hub diameter [mm]	G	24	J_1	kgcm ²	2.6	2.3	2	1.8	2.3	2.1	2.1	1.9	1.8	1.8	1.8
				10 ⁻³ in.lb.s ²	2.3	2	1.8	1.6	2	1.9	1.9	1.7	1.6	1.6	1.6

Please use our sizing software cymex® for a detailed sizing – www.wittenstein-cymex.com

^{a)} Valid for torque transmission only

^{b)} Valid for standard clamping hub diameter

^{c)} Refers to center of the output shaft or flange

^{d)} Please reduce input speed at higher ambient temperatures

^{e)} Valid for: Smooth shaft

^{g)} Applies at standstill, for details see operating instructions

1-stage

up to 24⁴⁾ (G)⁵⁾
clamping hub diameter

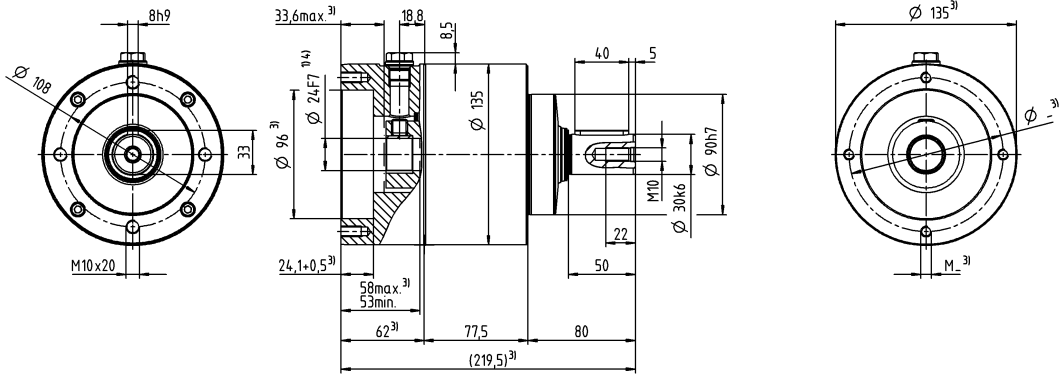

2-stage

up to 24⁴⁾ (G)⁵⁾
clamping hub diameter

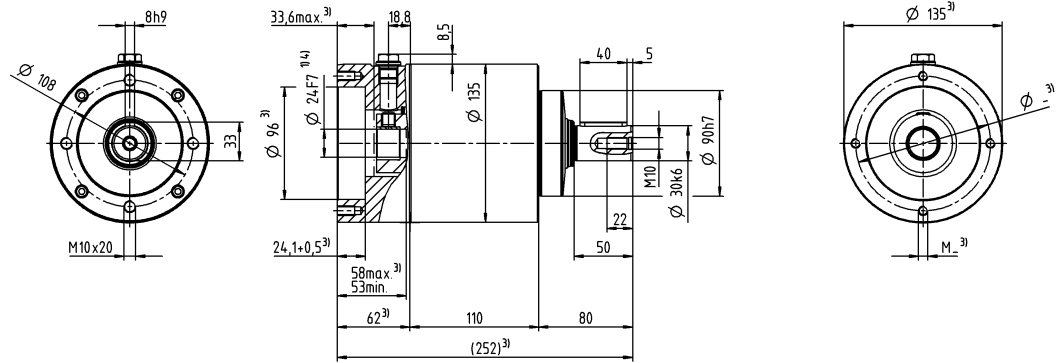

Motor shaft diameter [mm]

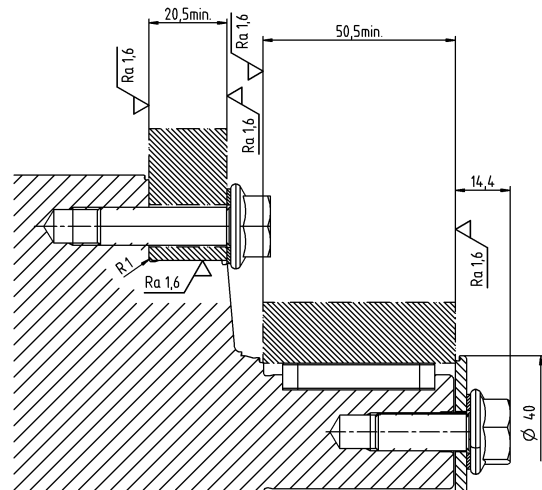

Other output variants

Smooth shaft

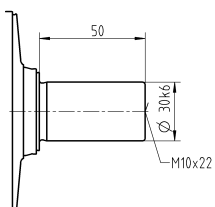

Mounting accessories:

Mounting kit comprising stainless steel screws, washers, seals and O-rings available as an option.

Non-tolerated dimensions are nominal dimensions

¹⁾ Check motor shaft fit

²⁾ Min. / Max. permissible motor shaft length

Longer motor shafts are possible, please contact alpha

³⁾ The dimensions depend on the motor

⁴⁾ Smaller motor shaft diameter is compensated by a bushing with a minimum wall thickness of 1 mm

⁵⁾ Standard clamping hub diameter

Basic Line gearbox overview



Product type		CP	CPS	CPK	CPSK	CVH	CVS
Version		MF	MF	MF	MF	MF / MT	MF / MT
Catalog pages		22	40	56	74	92	98
Ratio ^{c)}	min. $i =$	3	3	3	3	7	7
	max. $i =$	100	100	100	100	40	40
Max. torsional backlash [arcmin] ^{c)}	Standard	≤ 12	≤ 12	≤ 15	≤ 15	≤ 15	≤ 15
	Reduced	–	–	–	–	–	–
Output type							
Smooth shaft		x	x	x	x	–	x
Shaft with key ^{d)}		x	x	x	x	–	x
Splined shaft (DIN 5480)		–	–	–	–	–	–
Blind hollow shaft		–	–	–	–	–	–
Hollow shaft interface		–	–	–	–	x	–
Keyed hollow shaft		–	–	–	–	x	–
Flanged hollow shaft		–	–	–	–	–	–
Flange		–	–	–	–	–	–
System output		–	–	–	–	–	–
Output on both sides		–	–	–	–	x	x
Input type							
Motor-mounted		x	x	x	x	x	x
Self-contained version ^{b)}		–	–	–	–	–	–
Characteristic							
Flange with slotted holes		–	–	–	–	–	–
ATEX ^{a)}		–	–	–	–	–	–
Food-grade lubrication ^{a) b)}		x	x	x	x	x	x
Corrosion resistant ^{a) b)}		–	–	–	–	–	–
Optimized mass inertia ^{a)}		–	–	–	–	–	–
System solutions							
Linear system (rack/pinion)		–	–	–	–	–	–
Servo actuator		–	–	–	–	–	–
Accessories (please refer to the product pages for further options)							
Coupling		x	x	x	x	–	x
Shrink disc		–	–	–	–	x	–

^{a)} Power reduction: technical data available on request

^{b)} Please contact WITTENSTEIN alpha

^{c)} In relation to reference sizes

^{d)} Power reduction: Please use our sizing software cymex® for a detailed sizing – www.wittenstein-cymex.com

Value Line gearbox overview



Product type		NP	NPL	NPS	NPT	NPR	NTP	NPK	NPLK	NPSK	NPTK	NPRK	NVH	NVS	HDV
Version		MF/MA	MF/MA	MF/MA	MF/MA	MF/MA	MQ	MF	MF	MF	MF	MF	MF	MF	MF/MT
Catalog pages		110	134	154	174	198	218	238	254	268	282	298	316	322	332
Ratio ^{d)}	min. $i =$	3	3	3	3	3	4	3	3	3	3	3	4	4	4
	max. $i =$	100	100	100	100	100	100	100	100	100	100	100	400	400	400
Max. torsional backlash [arcmin] ^{e)}	Standard	≤ 8	≤ 8	≤ 8	≤ 8	≤ 8	≤ 5	≤ 11	≤ 11	≤ 11	≤ 11	≤ 11	≤ 6	≤ 6	≤ 10
	Reduced	-	-	-	-	-	-	-	-	-	-	-	-	-	-
Output type															
Smooth shaft		x	x	x	-	x	-	x	x	x	-	x	-	x	x
Shaft with key ^{d)}		x	x	x	-	x	-	x	x	x	-	x	-	x	x
Splined shaft (DIN 5480)		-	x	x	-	x	-	-	x	x	-	x	-	-	-
Blind hollow shaft		-	-	-	-	-	-	-	-	-	-	-	-	-	-
Hollow shaft interface		-	-	-	-	-	-	-	-	-	-	-	x	-	-
Keyed hollow shaft		-	-	-	-	-	-	-	-	-	-	-	x	-	-
Flanged hollow shaft		-	-	-	-	-	-	-	-	-	-	-	-	-	-
Flange		-	-	-	x	-	x	-	-	-	x	-	-	-	-
System output		-	-	-	-	-	-	-	-	-	-	-	-	-	-
Output on both sides		-	-	-	-	-	-	-	-	-	-	-	x	x	-
Input type															
Motor-mounted		x	x	x	x	x	x	x	x	x	x	x	x	x	x
Self-contained version ^{b)}		-	-	-	-	-	-	-	-	-	-	-	-	-	-
Characteristic															
Flange with slotted holes		-	-	-	-	x	-	-	-	-	-	x	-	-	-
ATEX ^{a)}		-	-	-	-	-	-	-	-	-	-	-	-	-	-
Food-grade lubrication ^{a) b)}		x	x	x	x	x	x	x	x	x	x	x	x	x	x
Corrosion resistant ^{a) b)}		-	-	-	-	-	-	-	-	-	-	-	x	x	x
Optimized mass inertia ^{a)}		-	-	-	-	-	-	-	-	-	-	-	-	-	-
System solutions															
Linear system (rack/pinion)		x	x	x	-	x	-	x	x	x	-	x	-	x	-
Servo actuator		-	-	-	-	-	-	-	-	-	-	-	-	-	x
Accessories (please refer to the product pages for further options)															
Coupling		x	x	x	x	x	x	x	x	x	-	x	-	x	-
Shrink disc		-	-	-	-	-	-	-	-	-	-	-	x	-	-

^{a)} Power reduction: technical data available on request

^{b)} Please contact WITTENSTEIN alpha

^{c)} In relation to reference sizes

^{d)} Power reduction: Please use our sizing software cymex® for a detailed sizing – www.wittenstein-cymex.com

Advanced Line gearbox overview



Product type		SP+	SP+ HIGH SPEED	SP+ HIGH SPEED friction optimized	TP+	TP+ HIGH TORQUE	HG+	SK+	SPK+
Version		MF	MC	MC-L	MF	MA	MF	MF	MF
Ratio ^{c)}	min. $i =$	3	3	3	4	22	3	3	12
	max. $i =$	100	100	10	100	302.5	100	100	10000
Max. torsional backlash [arcmin] ^{c)}	Standard	≤ 3	≤ 4	≤ 4	≤ 3	≤ 1	≤ 4	≤ 4	≤ 4
	Reduced	≤ 1	≤ 2	≤ 2	≤ 1	–	–	–	≤ 2
Output type									
Smooth shaft		x	x	x	–	–	–	x	x
Shaft with key ^{d)}		x	x	x	–	–	–	x	x
Splined shaft (DIN 5480)		x	x	x	–	–	–	x	x
Blind hollow shaft		x	x	x	–	–	–	–	x
Hollow shaft interface		–	–	–	–	–	x	–	–
Keyed hollow shaft		–	–	–	–	–	–	–	–
Flanged hollow shaft		–	–	–	–	–	–	–	–
Flange		–	–	–	x	x	–	–	–
System output		–	–	–	x	x	–	–	–
Output on both sides		–	–	–	–	–	x	x	x
Input type									
Motor-mounted		x	x	x	x	x	x	x	x
Self-contained version ^{b)}		x	–	–	x	–	–	–	–
Characteristic									
Flange with slotted holes		x	–	–	–	–	–	–	–
ATEX ^{a)}		x	x	–	–	–	x	x	–
Food-grade lubrication ^{a) b)}		x	x	x	x	x	x	x	x
Corrosion resistant ^{a) b)}		x	x	x	x	x	x	x	x
Optimized mass inertia ^{a)}		x	x	x	x	x	–	–	–
System solutions									
Linear system (rack/pinion)		x	x	–	x	x	–	x	x
Servo actuator		x	–	–	x	x	–	–	–
Accessories (please refer to the product pages for further options)									
Coupling		x	x	x	x	x	–	x	x
Shrink disc		x	x	x	–	–	x	–	x

^{a)} Power reduction: technical data available on request

^{b)} Please contact WITTENSTEIN alpha

^{c)} In relation to reference sizes

^{d)} Power reduction: Please use our sizing software cymex[®] for a detailed sizing – www.wittenstein-cymex.com



TK+	TPK+	TPK+ HIGH TORQUE	SC+	SPC+	TPC+	VH+	VS+	VT+	DP+	HDP+
MF	MF	MA	MF	MF	MF	MF	MF	MF	MF / MA	MA
3	12	66	1	4	4	4	4	4	16	22
100	10000	5500	2	20	20	400	400	400	55	55
≤ 4	≤ 4	≤ 1.3	≤ 4	≤ 4	≤ 4	≤ 3	≤ 3	≤ 3	≤ 3	≤ 1
-	≤ 2	-	-	≤ 2	≤ 2	≤ 2	≤ 2	≤ 2	≤ 1	-

-	-	-	x	x	-	-	x	-	-	-
-	-	-	x	x	-	-	x	-	-	-
-	-	-	-	x	-	-	x	-	-	-
-	-	-	-	x	-	-	-	-	-	-
-	-	-	-	-	-	x	-	-	-	-
-	-	-	-	-	-	x	-	-	-	-
x	-	-	-	-	-	-	-	x	-	-
-	x	x	-	-	x	-	-	-	x	x
-	x	x	-	-	x	-	-	-	-	-
x	x	x	-	-	-	x	x	-	-	-

x	x	x	x	x	x	x	x	x	x	x
-	-	-	-	-	-	-	-	-	-	-

-	-	-	-	-	-	-	-	-	-	-
x	-	-	-	-	-	-	-	-	-	-
x	x	x	x	x	x	x	x	x	x	x
x	x	x	-	-	-	x	x	x	x	x
-	-	-	-	-	-	-	-	-	x	x

x	x	x	x	x	x	-	x	x	-	-
-	-	-	-	-	-	-	-	-	-	-

x	x	x	x	x	x	-	x	x	-	-
-	-	-	-	x	-	x	-	-	-	-

Premium Line gearbox overview



Product type		XP+	XP+ HIGH TORQUE	XP+ HIGH SPEED	RP+	RP+ HIGH TORQUE	XPK+	RPK+	XPC+	RPC+
Version		MF	MA	MC	MF	MA	MF	MA	MF	MA
Ratio ^{c)}	min. $i =$	3	5.5	3	4	5.5	12	48	4	22
	max. $i =$	100	55	100	10	220	1000	5500	20	55
Max. torsional backlash [arcmin] ^{c)}	Standard	≤ 3	≤ 1	≤ 4	≤ 3	≤ 1	≤ 4	≤ 1.3	≤ 4	≤ 1.3
	Reduced	≤ 1	–	≤ 2	≤ 1	–	≤ 2	–	≤ 2	–
Output shape										
Smooth shaft		x	x	x	–	–	x	–	x	–
Shaft with key ^{d)}		x	–	x	–	–	x	–	x	–
Splined shaft (DIN 5480)		x	x	x	–	–	x	–	x	–
Blind hollow shaft		x	x	x	–	–	x	–	x	–
Hollow shaft interface		–	–	–	–	–	–	–	–	–
Keyed hollow shaft		–	–	–	–	–	–	–	–	–
Flanged hollow shaft		–	–	–	–	–	–	–	–	–
Flange		–	–	–	x	x	–	x	–	x
System output		x	x	x	x	x	x	x	x	x
Output on both sides		–	–	–	–	–	–	–	–	–
Input type										
Motor-mounted		x	x	x	x	x	x	x	x	x
Self-contained version ^{b)}		x	–	–	–	–	–	–	–	–
Characteristic										
Flange with slotted holes		x	x	x	x	x	x	x	x	x
ATEX ^{a)}		–	–	–	–	–	–	–	–	–
Food-grade lubrication ^{a) b)}		x	x	x	x	x	x	x	x	x
Corrosion resistant ^{a) b)}		–	–	–	–	–	–	–	–	–
Optimized mass inertia ^{a)}		x	–	x	x	x	–	–	–	–
System solutions										
Linear system (rack / pinion)		x	x	x	x	x	x	x	x	x
Servo actuator		x	–	–	x	x	–	–	–	–
Accessories (please refer to the product pages for further options)										
Coupling		x	x	x	–	–	x	–	x	–
Shrink disc		x	x	x	–	–	x	–	x	–

^{a)} Power reduction: technical data available on request

^{b)} Please contact WITTENSTEIN alpha

^{c)} In relation to reference sizes

^{d)} Power reduction: Please use our sizing software cymex® for a detailed sizing – www.wittenstein-cymex.com

Servo actuator overview



Product type		PBG	PAG	PHG	RPM ^a	TPM ⁺ DYNAMIC	TPM ⁺ HIGH TORQUE	TPM ⁺ POWER	AVF
Version		Standard	Standard	Standard	Customer specific	Standard	Standard	Standard	Standard
Ratio ^c	min. $i =$	16	16	16	22	16	22	4	10
	max. $i =$	100	100	100	220	91	220	100	25
Max. torsional backlash ^c [arcmin]	Standard	≤ 5	≤ 3	≤ 4	≤ 1	≤ 3	≤ 1	≤ 3	≤ 10
	Reduced	≤ 3	≤ 1	≤ 2	–	≤ 1	≤ 1	≤ 1	–
Output shape									
Smooth shaft		x	–	x	–	–	–	–	x
Shaft with key ^d		x	–	x	–	–	–	–	x
Splined shaft (DIN 5480)		x	–	x	–	–	–	–	–
Blind hollow shaft		–	–	–	–	–	–	–	–
Hollow shaft interface		–	–	–	–	–	–	–	–
Keyed hollow shaft		–	–	–	–	–	–	–	–
Flanged hollow shaft		–	–	–	–	–	–	–	–
Flange		–	x	–	x	x	x	x	–
System output		–	x	x	x	x	x	x	–
Output on both sides		–	–	–	–	–	–	–	–
Input type									
Motor-mounted		–	–	–	–	–	–	–	–
Self-contained version		–	–	–	–	–	–	–	–
Characteristic									
Flange with slotted holes		–	–	x	x	–	–	–	–
ATEX ^{a)}		–	–	–	–	–	–	–	–
Food-grade lubrication ^{a) b)}		x	x	x	x	x	x	x	x
Corrosion resistant ^{a) b)}		–	–	–	–	x	x	x	x
Optimized mass Inertia ^{a)}		–	–	–	–	–	–	–	–
System solutions									
Linear system (rack / pinion)		x	x	x	x	x	x	x	–
Accessories (please refer to the product pages for further options)									
Coupling		x	x	–	–	x	x	x	–
Shrink disc		x	–	x	–	–	–	–	–
Power cable, signal cable, hybrid cable		x	x	x	x	x	x	x	x

^{a)} Power reduction: technical data available on request

^{b)} Please contact WITTENSTEIN alpha

^{c)} In relation to reference sizes

^{d)} Power reduction: Please use our sizing software cymex[®] for a detailed sizing – www.wittenstein-cymex.com

Overview of output interfaces

Rotative output interfaces



Smooth shaft

- Friction contact torque transmission via a clamp connection (e.g. in connection with a coupling)
- Simple connection of the gearbox to the application
- Consistently high transmittable torques even with highly cyclical changing loads
- Classic output interface for the shaft gears in the alpha Advanced Line and alpha Premium Line



Shaft with key

- Form fit torque transmission via the key in the cylindrical gearbox output¹
- Easy to assemble and disassemble
- Cost-efficient solution for connecting the gearbox to the application
- Form fit locking of the shaft against slipping
- Danger of deflection with highly cyclical changing loads
- Not suitable for applications with high requirements in terms of repeatability
- Common output interface for the shaft gears in the alpha Basic Line and alpha Value Line



Splined shaft (DIN 5480)

- Form fit torque transmission via the tooth flanks of the output shaft
- Easy to assemble and disassemble
- Consistently high transmittable torques even with highly cyclical changing loads
- Requires little space
- Higher demands on design and production
- Used for connecting RMS pinions to the gearbox (see the alpha Linear Systems product catalog)



Flange output

- Friction contact torque transmission by screwing the application to the face of the gearbox output²
- Maximum torsional rigidity and torque transmission even with highly cyclical changing loads
- Simple and space-saving mounting base



Blind hollow shaft⁴

- Friction contact torque transmission via a hollow-shaft-like interface on the gearbox output for connecting the application to a shrink disc³
- Reduced space requirement due to elimination of connecting elements (e.g. couplings)



System output as the basis for RMW pinions (see alpha Linear Systems product catalog)

- Cohesive connection of the output flange with a pinion
- Highly flexible interface for connecting different pinion variants and geometries
- Maximum linear rigidity through the direct connection of pinions with a small reference pitch diameter
- Maximum safety and reliability
- Compact design



Flanged hollow shaft

- Friction contact torque transmission by screwing the application to the face of the gearbox output²
- Combination of flange output and hollow shaft for maximum use of space for feeding through e.g. cable harnesses or a shaft
- Maximum torsional rigidity and torque transmission even with highly cyclical changing loads
- Simple and space-saving mounting base



Hollow shaft interface⁴

- Friction contact torque transmission via cylindrical shoulder on the gearbox output for connecting the application to a shrink disc
- Hollow shaft for feeding through e.g. cable harnesses or a shaft
- Requires little space
- Complex mechanical calculation in the event of tilting moments or lateral forces



Keyed hollow shaft⁴

- Form fit torque transmission via the combination of the hollow shaft and a feather keyway¹
- Hollow shaft for feeding through e.g. cable harnesses or a shaft
- Easy to assemble and disassemble
- Form fit safeguard of the shaft against slipping
- Requires little space
- Danger of deflection with highly cyclical changing loads
- Not suitable for applications with high requirements in terms of repeatability



Output on both sides

- Version of the gearbox with a second, rear output
- Use as input for an additional mounting base
- No reduction in the permitted speeds and torques on both output sides, except in gearboxes with additional planetary output stages (e.g. SPK+, TPK+); these gearboxes also have higher speeds at the rear output.
- Reduced absorption of axial and lateral forces on the rear output

¹⁾ The cymex® 5 sizing software performs standard calculations in this regard. Assistance from WITTENSTEIN is possible if required.

²⁾ The reliability of the screws depends largely on the screws used, the screw tightening procedure, and the cleaning procedure for the screws during assembly. Recommendations in this regard are included in the operating manual.

³⁾ For radial loads, a case-by-case check by WITTENSTEIN is recommended.

⁴⁾ To prevent overdetermination of the system, a torque support is recommended.

Value Linear Systems

System solutions count

The Value Linear Systems are adapted to linear applications in the Value Segment with comparatively low requirements in terms of smooth running, positioning accuracy, and feed force. The systems are typically used in woodworking machinery, plasma cutting systems, and automation.

High-end technology – the R-flange

The R-flange adapted from the Premium Segment allows greater design freedom in the Value Segment. The gearbox flange with integrated slots enables easy positioning of the gearbox with mounted pinion in relation to the rack. Cumber- some solutions with complicated designs featuring intermedi- ate plates are therefore not required.

The alpha preferred Linear System

Our preferred Linear Systems in the Value Segment are the ideal combination of gearbox, pinion, rack, and lubrica- tion system. The systems have been optimized to achieve the required feed force, feed speed, stiffness, and deg- ree of utilization of the individual components. They cover a feed force range of up to 8,000 N. Feed speeds of up to 400 m/min are possible.

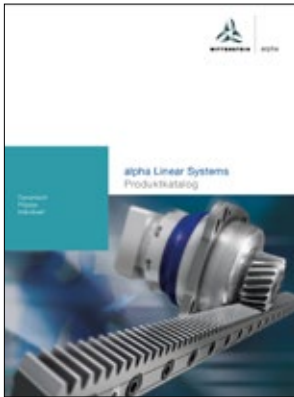

Refer to our alpha Linear Systems catalog and the website for more information on the Value, Advanced, and Premium Linear System.

www.wittenstein-alpha.com/linear-systems

For a wide range of applications

alpha Linear Systems are suitable for a wide range of applica- tions and industries. New standards are being set in the fol- lowing areas:

- Smooth running
- Positioning accuracy
- Feed force
- Power density
- Rigidity
- Ease of installation
- Structural design
- Scalability

Paired with a comprehensive range of services, we support you from the constructional draft to sizing, assembly, and commis- sioning. We will also ensure a consistent supply of spare parts.

The benefits of the alpha Linear Systems for you

- Perfectly matched components
- Maximum efficiency and power density
- Exceptional Linear System rigidity for even greater dynamics and precision
- Simple mounting and perfect integration in the drive train
- Available in different sizes, power categories, and segments

Consultation and quality – everything from a single source!



premo – servo actuators by WITTENSTEIN alpha

premo is the new, powerful servo actuator platform that combines absolute precision with perfect movement. The central idea behind this first fully scalable servo actuator platform is uncompromising flexibility from the viewpoint of the user: motors and gearboxes with application-related graduated performance characteristics can be configured modularly into individual servo actuators. The result is a highly versatile modular system with customizable power, designed for a wide range of applications. The core of the servo actuator is a torsionally rigid precision gearbox with low backlash and excellent torque density combined with the equally powerful, permanent magnet servo motor with an evenly distributed winding that guarantees low cogging and high speed constancy.

Typical areas of application and industry solutions

- Delta robot (axes 1–3, swivel axis)
- Handling gantry (Z-axis, swivel/rotating axis)
- Machine tool milling (rotating axes A–C, tool changer)
- Fill and seal machine (incl. jaw stroke, sealing jaw, blade)
- Folding carton packaging (incl. assembly/folding, filling valve)
- Plastic thermoform (tool axis)

premo application examples

premo PRODUCT HIGHLIGHTS

- Optimized power density for greater energy efficiency and productivity
- Flexible mechanical and electrical interfaces for high scalability
- Individual upgrading of the basic configuration through a variety of options



Handling gantry
premo SP Line

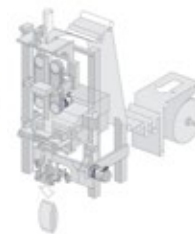

Fill and seal machine
premo TP Line



Milling head of a
machining center
premo XP Line

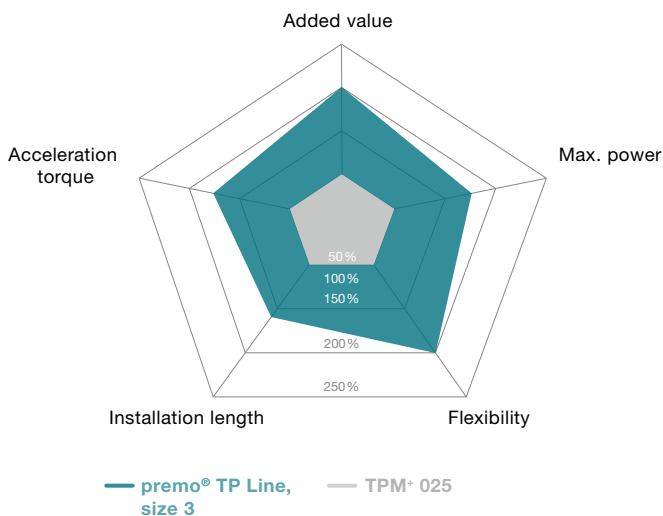

premo SP Line

premo TP Line

premo XP Line

cynapse® – It's new. It's connective. The smart feature.

Cybertronic drive systems that can independently acquire and communicate information are an essential prerequisite for IIoT. WITTENSTEIN alpha is the first component manufacturer to offer smart gearboxes as standard – gearboxes with cynapse®. They have an integrated sensor module that makes Industry 4.0 connectivity possible.

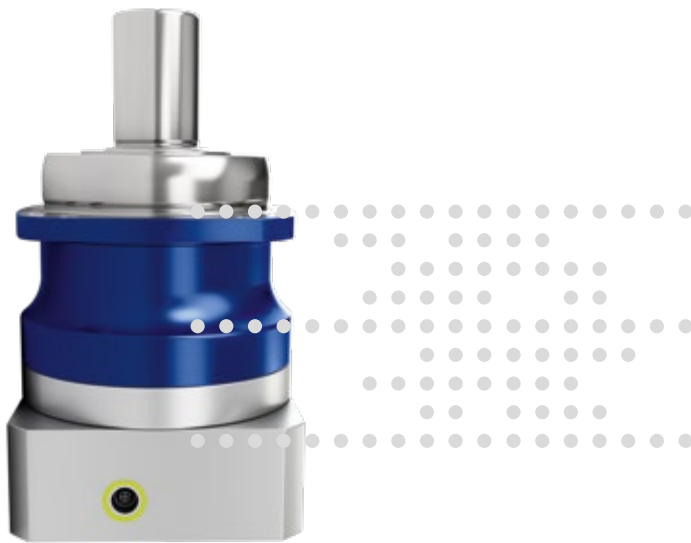

cynapse®
play IIoT

cynapse® – how it works

cynapse® ensures the gearbox can be easily integrated into the digital world. The cynapse® feature is integrated into the existing installation space and is connected via an IO-Link interface. As a result, measured data such as the gearbox's **temperature, vibration, operating time, acceleration, and product-specific information** can be accessed.

cynapse® wins customers over with:

- Sensor module integrated into the installation space
- Simple connection by IO-Link interface
- Gearbox threshold monitoring
- Quick product identification thanks to digital name plate

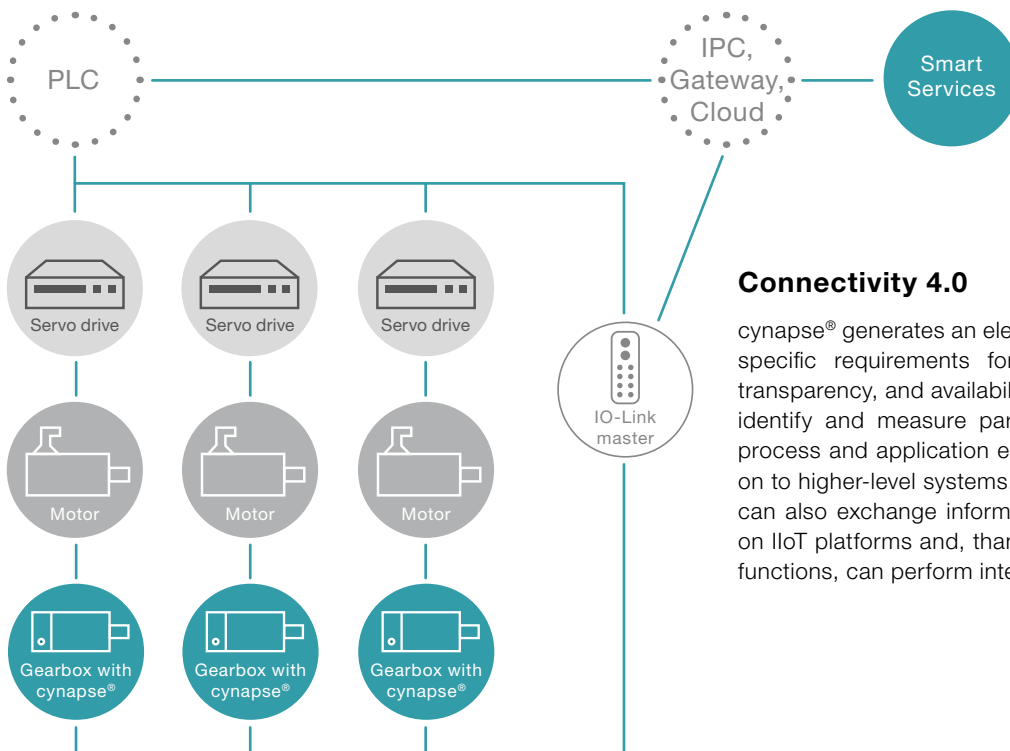

Connectivity 4.0

cynapse® generates an electronic “fingerprint” of your specific requirements for performance, efficiency, transparency, and availability. The smart gearbox can identify and measure parameters directly from the process and application environment and pass them on to higher-level systems. Gearboxes with cynapse® can also exchange information with the applications on IIoT platforms and, thanks to their integrated logic functions, can perform intelligent monitoring tasks.

Smart Services – the perfect complement

The Smart Services expand the functional scope of the cynapse® feature. The basic functions comprise data processing, visualization, and analysis. The specific expertise, which WITTENSTEIN has gathered over more than 40 years of developing low-backlash planetary gearboxes, is used in combination with the operating data to establish and display the status of the gearbox in the Smart Services.

Your benefits at a glance

- Visualization of the operating data
- Simple and convenient integration
- Determination and monitoring of critical threshold values
- Early identification of problematic statuses
- Avoidance of machine downtimes and associated costs
- Transparency for drive axis

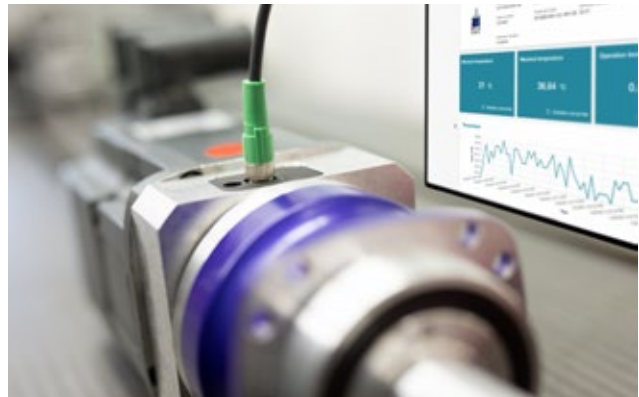

cynapse® Connect

cynapse® Connect enables integration and routing of data, which is a fundamental prerequisite for condition monitoring. The Smart Service makes the recorded data available in a structured format. It can obtain this data from various source systems via IO-Link or OPC UA and utilizes it for digital services from WITTENSTEIN. cynapse® Connect thus greatly simplifies the integration of smart gearboxes into the relevant machine infrastructure.



cynapse® Monitor

cynapse® Monitor builds upon the Smart Service cynapse® Connect and enables straightforward evaluation and visualization of operating data. Since manufacturers and operators do not have to develop their own solutions, development requirements are massively reduced. In addition, the data of the cynapse® Monitor service can be used to monitor threshold values of selected parameters. Deviations and critical states in the behavior of gearboxes or in the relevant process can therefore be identified at an early stage.



cynapse® Analyze

cynapse® Analyze is an ever-growing portfolio of smart features. The focus of this service is the detection of anomalies or wear. The Anomaly-Check, for example, detects changes in the belt tension in packaging machine drives. The Health Index displays the gearbox condition simply and intuitively by means of a traffic light, which can be used to establish the recommended course of action. These features help to prevent unplanned downtimes as well as the associated breakdown and repair costs. Machine operators can thus take the necessary action before any damage occurs.



Accessories – smart additions for intelligent performance

Gearboxes, accessories and consulting from a single source

Optimization of your added value chain
Use the combination of gearbox and accessories in a complete package to streamline your internal processes.

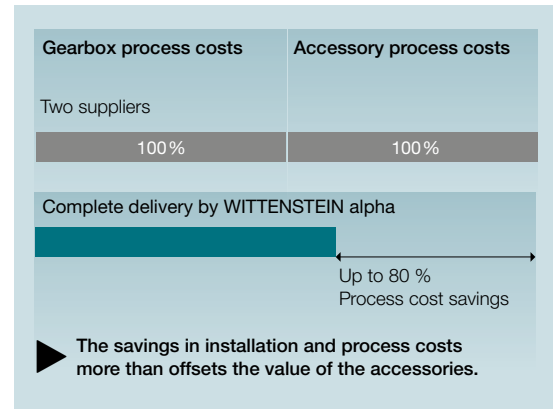
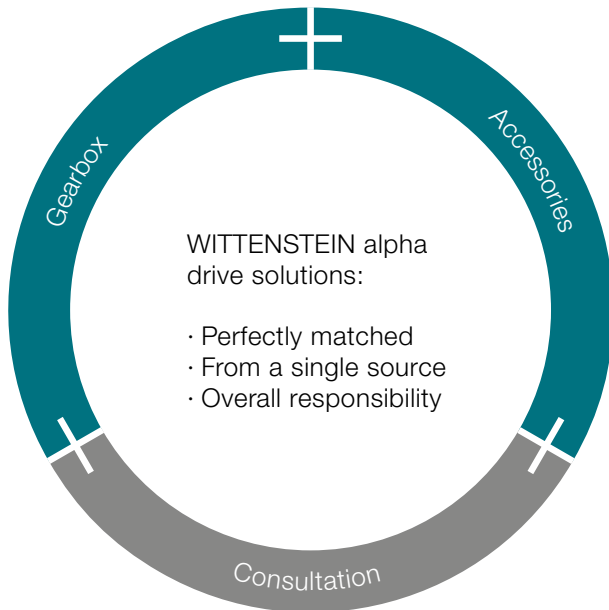

Quick selection

PRODUCTS	COUPLING	SHRINK DISC
Basic Line		
CP / CPK	ELC	
CPS / CPSK	ELC	
CVH		SD
CVS	ELC	
Value Line		
NP / NPK	ELC	
NPL / NPLK	ELC	
NPS / NPSK	ELC	
NPT / NPTK / NTP	ELT	
NPR / NPRK	ELC	
NVH		SD
NVS	ELC	

PRODUCTS	COUPLING	SHRINK DISC
Advanced Line		
SP ⁺ / SPK ⁺ / SPC ⁺	BC2	SD
TP ⁺ / TPK ⁺ / TPC ⁺	BCT	
TP ⁺ / TPK ⁺ HIGH TORQUE	BCT	
HG ⁺		SD
SK ⁺	BC2	
TK ⁺	BCT	SD
SC ⁺	BC2	
VH ⁺		SD
VS ⁺	BC3	
VT ⁺	BCT	
premo [®] SP Line	BC2	
premo [®] TP Line	BCT	
TPM ⁺ DYNAMIC		
TPM ⁺ HIGH TORQUE	BCT	
TPM ⁺ POWER		

Premium Line		
XP ⁺ / XPK ⁺ / XPC ⁺	BC3	
premo [®] XP Line	BC3	

Couplings

Couplings are used for compensating misalignment during assembly and material-related heat expansion

Compensation for shaft misalignment

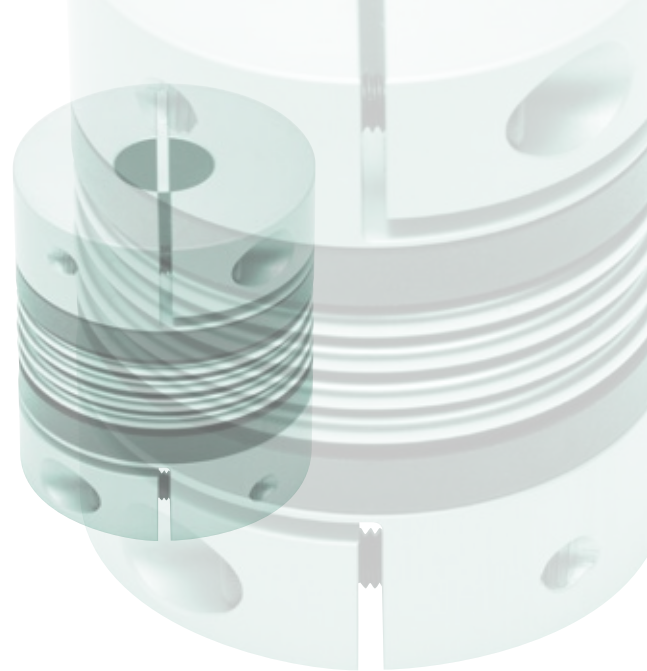
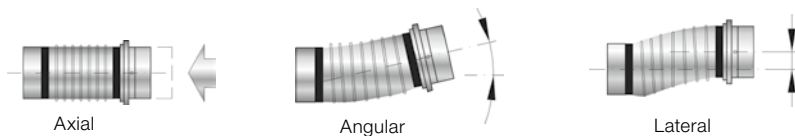

Metal bellows coupling

- Compensation for shaft misalignment
- Completely backlash free
- Corrosion resistant version available as an option (BC2, BC3, BCT)
- High torsional rigidity



Elastomer coupling

- Compensation for shaft misalignment
- Completely backlash free
- Selectable torsional rigidity/damping
- Compact design
- Extremely simple installation (plug-in)



Torque limiter

- Compensation for shaft misalignment
- Completely backlash free
- Precise, preset overload protection (switch-off in 1 – 3 ms)
- Precise repeat accuracy
- Just one protection element per axis

Preferred coupling series

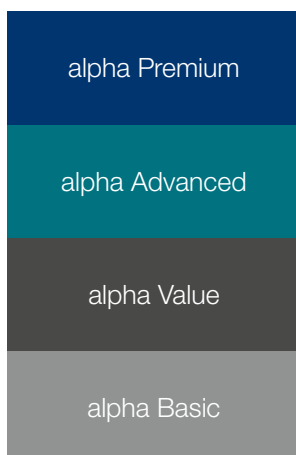

Preferred series are defined for the relevant gearbox segments to make selection easier. Preferred couplings are defined based on the maximum torque that the gearbox can transmit. Standard industrial conditions for the number of cycles (1000/h) and ambient temperature were adopted.

Please note that the coupling load is based on the torque that the gearbox can transmit and not the torque in your application. We recommend using our cymex® 5 design software to create a more detailed design. (www.wittenstein-cymex.com)

For more coupling types, please visit www.wittenstein-alpha.com

Shrink disks

Shrink disks are frictional hub / shaft connections. Together with our hollow shaft or mounted shaft gearboxes for mounting directly on load shafts, machines can be designed to take up a minimal installation space.

The benefits:

- Simple mounting and removal
- Quick selection, easy and convenient
- Optional: corrosion resistant version

Preferred shrink disk series

To view a wide range of nickel-plated, stainless steel and other shrink disks as well as all the relevant technical data and dimensions, visit our homepage

www.wittenstein-alpha.com



Quick shrink disc selection

Gearbox		Version			Geometry					
		Standard	Nickel-plated	Stainless steel	d	D	A	H*	H2*	J [kgcm ²]
HG ⁺ / SP ⁺ / SPC ⁺ 060	Ordering code	SD 018x044 S2	SD 018x044 N2	SD 018x044 E2	18	44	30	15	19	0.252
	Material number	20000744	20048496	20048491						
	T _{2Max} [Nm]	100	51	51						
HG ⁺ / SP ⁺ / SPK ⁺ / SPC ⁺ 075	Ordering code	SD 024x050 S2	SD 024x050 N2	SD 024x050 E2	24	50	36	18	22	0.729
	Material number	20001389	20047957	20043198						
	T _{2Max} [Nm]	250	136	136						
HG ⁺ / SP ⁺ / SPK ⁺ / SPC ⁺ 100	Ordering code	SD 036x072 S2	SD 036x072 N2	SD 036x072 E2	36	72	52	22	27.5	3.94
	Material number	20001391	20048497	20035055						
	T _{2Max} [Nm]	650	575	450						
HG ⁺ / SP ⁺ / SPK ⁺ / SPC ⁺ 140	Ordering code	SD 050x090 S2	SD 050x090 N2	SD 050x090 E2	50	90	68	26	31.5	11.1
	Material number	20001394	20048498	20047937						
	T _{2Max} [Nm]	1320	1015	770						
HG ⁺ / SP ⁺ / SPK ⁺ / SPC ⁺ 180	Ordering code	SD 068x115 S2	SD 068x115 N2	SD 068x115 E2	68	115	86	29	34.5	31.1
	Material number	20001396	20048499	20048492						
	T _{2Max} [Nm]	2450	1820	1500						
VH ⁺ / NVH / CVH 040	Ordering code	SD 024x050 S2	SD 024x050 N2	SD 024x050 E2	24	50	36	18	22	0.729
	Material number	20001389	20047957	20043198						
	T _{2Max} [Nm]	250	136	136						
VH ⁺ / NVH / CVH 050	Ordering code	SD 030x060 S2V	SD 030x060 N2	SD 030x060 E2	30	60	44	20	24	1.82
	Material number	20020687	20047934	20047885						
	T _{2Max} [Nm]	550	375	230						
VH ⁺ / NVH / CVH 063	Ordering code	SD 036x072 S2V	SD 036x072 N2V	SD 036x072 E2	36	72	52	22	27.5	3.94
	Material number	20020688	20047530	20035055						
	T _{2Max} [Nm]	640	560	450						
VH ⁺ 080	Ordering code	SD 050x090 S2V	SD 050x090 N2V	SD 050x090 E2	50	90	68	26	31.5	11.1
	Material number	20020689	20047935	20047937						
	T _{2Max} [Nm]	1400	950	900						
VH ⁺ 100	Ordering code	SD 062x110 S2V	SD 062x110 N2	SD 062x110 E2	62	110	80	29	34.5	27
	Material number	20020690	20047927	20047860						
	T _{2Max} [Nm]	2300	1540	1000						

*Applicable to the unclamped condition. ** Maximum torque without axial forces. Shrink discs suitable for XP⁺ gearboxes upon request

One shrink disk per gearhead is sufficient.

Refer to the operating manual for information on correct shrink disc installation and additional cleaning instructions, particularly for stainless steel shrink disks.

The instructions are enclosed with the order.

Mounting/operating manual at www.wittenstein-alpha.de/en/

Recommendation for the load shaft:

Tolerance h6

Surface roughness ≤ Rz 16

Minimum yield strength (standard) Rp 0.2 ≥ 385 N/mm²

Minimum yield strength (nickel-plated) Rp 0.2 ≥ 260 N/mm²

Minimum yield strength (stainless steel) Rp 0.2 ≥ 260 N/mm²

The shrink disc is not included in the scope of delivery of the gearhead. Therefore, it must be ordered separately.

Support at each interaction stage

With the WITTENSTEIN alpha service concept, we are also setting new standards in the field of customer support.

DESIGN



We offer the right sizing methodology for every requirement. Whether easy downloading of CAD data, quick and easy calculation, or precise sizing of the drive train.

STARTUP



Our service experts are happy to support you in the installation and startup of complex mechatronic systems, guaranteeing maximum availability of your plant.

SERVICING



WITTENSTEIN alpha guarantees fast repairs of the highest quality and precision. In addition, we will provide you with information about various measurements, material analyses, and condition monitoring inspections.



Consultation

- Personal contact on site
- Competent application calculations and drive sizing

Engineering

Catalog gearboxes:

- Advanced software tools for accurate calculation, simulation, and analysis of the drive train
- Optimization of your productivity

Special gearboxes:

- Development and production of customized gearboxes
- Gearing design and development
- Inquiries: sondergetriebe@wittenstein.de



CAD POINT
YOUR SMART CATALOG



cymex[®] select
BEST SOLUTION WITHIN SECONDS



cymex[®] 5
CALCULATE ON THE BEST

See pages 12–15 for more information about the software tools



speedline[®] delivery

Tel. +49 7931 493-10444

- Delivery of standard product range in 24 or 48 hours ex works*
- Fast deliveries at short notice

Installation on site

- Professional installation
- Optimal application integration
- Introduction to the operation of the drive

Operating and installation instructions

- Detail description of how to use the product
- Installation and motor mounting videos

* Non-binding delivery time depending on part availability



WITTENSTEIN Service Portal
One gate. All support.

WITTENSTEIN Service Portal

- Instant Access to Product Information
- Quick Installation and Commissioning for example Tutorial-Videos

Pick-up & return service

- Minimization of downtimes
- Professional logistics organization
- Reduction of transport risks



24 h service hotline

Tel. +49 7931 493-12900

Maintenance and inspection

- Documentation regarding condition and expected service life
- Customer-specific maintenance schedules

Repairs

- Repair to nominal condition
- Immediate response in time-critical situations

cymex[®] statistics

- Systematic field data acquisition
- Reliability calculations (MTBF)



WITTENSTEIN Service Portal
One gate. All support.

WITTENSTEIN Service Portal

- Fast Processing of Replacement Products
- The Right Contact for Queries
- Tailor-Made Maintenance Services

Modernization

- Professional retrofitting
- Reliable compatibility testing of existing solutions



Individual training without limits

All delivered products are perfectly matched to your application environment and immediately 100 % operational.

Our service experts support you in the commissioning of complex mechatronic systems, guaranteeing maximum availability of your plant.

Product training

Greater knowledge enables greater achievement. We will be pleased to share our expert knowledge with you: Profit from our many years of experience and learn more about the product portfolio of WITTENSTEIN alpha.

Installation training

We offer you individual training courses on-site for your system application of selected linear axes as well as professional installation.

Sizing training

Become a design expert! We will provide you with training courses on our design software, adapted to your requirements. Whether for beginners or experts, for occasional or regular users – we adapt our training course to your wishes and requirements.

Service training

Participation in a service training course is a prerequisite for sourcing spare parts at the parts list level. We offer you training courses at our premises or on-site at your plant. Moreover, we regularly host maintenance workshops at which the participants are instructed in safe handling during mounting of the motor to the gearbox as well as the independent replacement of wearing parts and gearbox assemblies.

Global presence. Personal consultation.

No matter where you need us:

A comprehensive sales and service network provides quick availability and competent support worldwide.

24 h service hotline: +49 7931 493-12900

The WITTENSTEIN group – The company and its fields of business



WITTENSTEIN

With approximately 2,800 employees worldwide, the WITTENSTEIN group stands for innovation, precision and excellence in the world of mechatronic drive technology, both nationally and internationally. The group is active in seven innovative fields of business. Furthermore, WITTENSTEIN group is represented by some 60 subsidiaries in around 40 countries in all important technology and sales markets worldwide.



Our fields of expertise

We provide know-how for a host of different sectors:

- Machine and plant construction
- Software development
- Aerospace
- Automotive & E-mobility
- Energy
- Oil & Gas Exploration and Production
- Medical technology
- Measurement and testing technology
- Nanotechnology
- Simulation

The WITTENSTEIN Group



WITTENSTEIN alpha GmbH
High-precision servo drives and linear systems



WITTENSTEIN cyber motor GmbH
Highly dynamic servo motors and drive electronics



WITTENSTEIN galaxie GmbH
Superior gearboxes and drive systems



WITTENSTEIN motion control GmbH
Drive systems for the most extreme environmental requirements

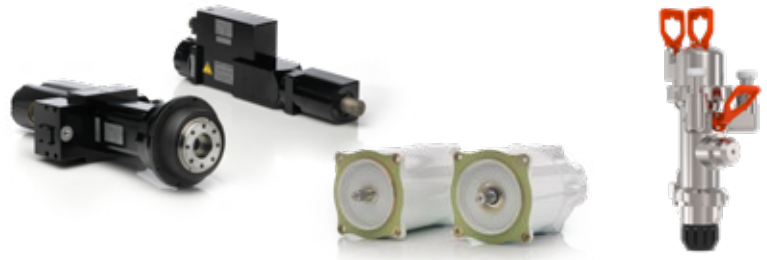

attocube systems AG
Nanoprecision drive and measurement technology solutions



baramundi software GmbH
Secure management of the IT infrastructure in offices and production



Product portfolio &
company

WITTENSTEIN – one with the future

Planetary/bevel gearbox – detailed sizing

The following diagram describes the steps involved in sizing planetary and bevel gearboxes. Please use cymex® - www.wittenstein-cymex.com - for detailed sizing.

Diagram: cyclic operation **S5** and continuous operation **S1**

Determining the duty cycle DC

$$DC = \frac{(t_b + t_c + t_d)}{(t_b + t_c + t_d + t_e)} \cdot 100$$

$$DC = t_b + t_c + t_d$$

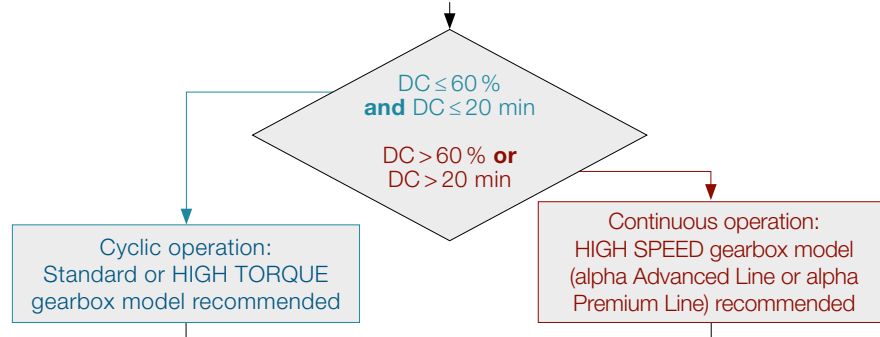

See glossary: "Continuous operation"

$$Z_n = \frac{3600}{(t_b + t_c + t_d + t_e)} \quad \text{See diagram 1}$$

f_s is dependent on Z_n See diagram 2

T_{2b} depends on the application

$$T_{2b, fs} = T_{2b} \cdot f_s$$

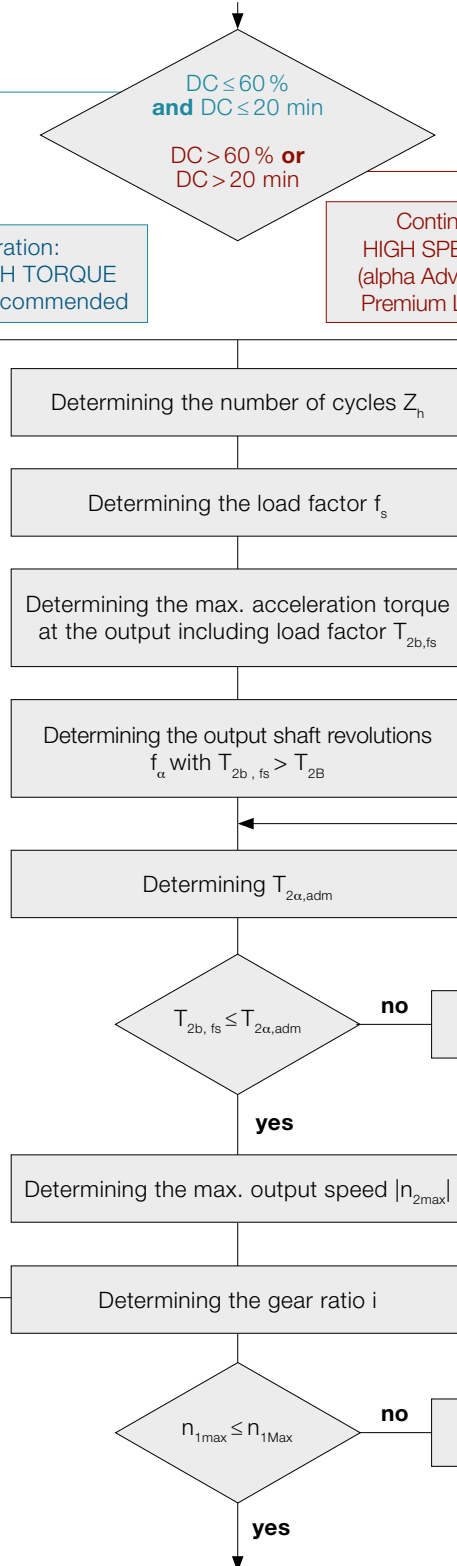

i dependent on
 - required output speed (application)
 - useful input speed (gearbox/motor)

$$n_{1max} = n_{2max} \cdot i$$

$$n_{1Mot max} \geq n_{1max}$$

T - corresponding to output and input torque

$$T_{1b} = T_{2b} \cdot \frac{1}{i} \cdot \frac{1}{\eta} + T_{012} \quad T_{Mot max} > T_{1b}$$

λ - from resulting inertia ratio
 Guide value: $1 \leq \lambda \leq 10$
 (See **alphabet** for calculation)

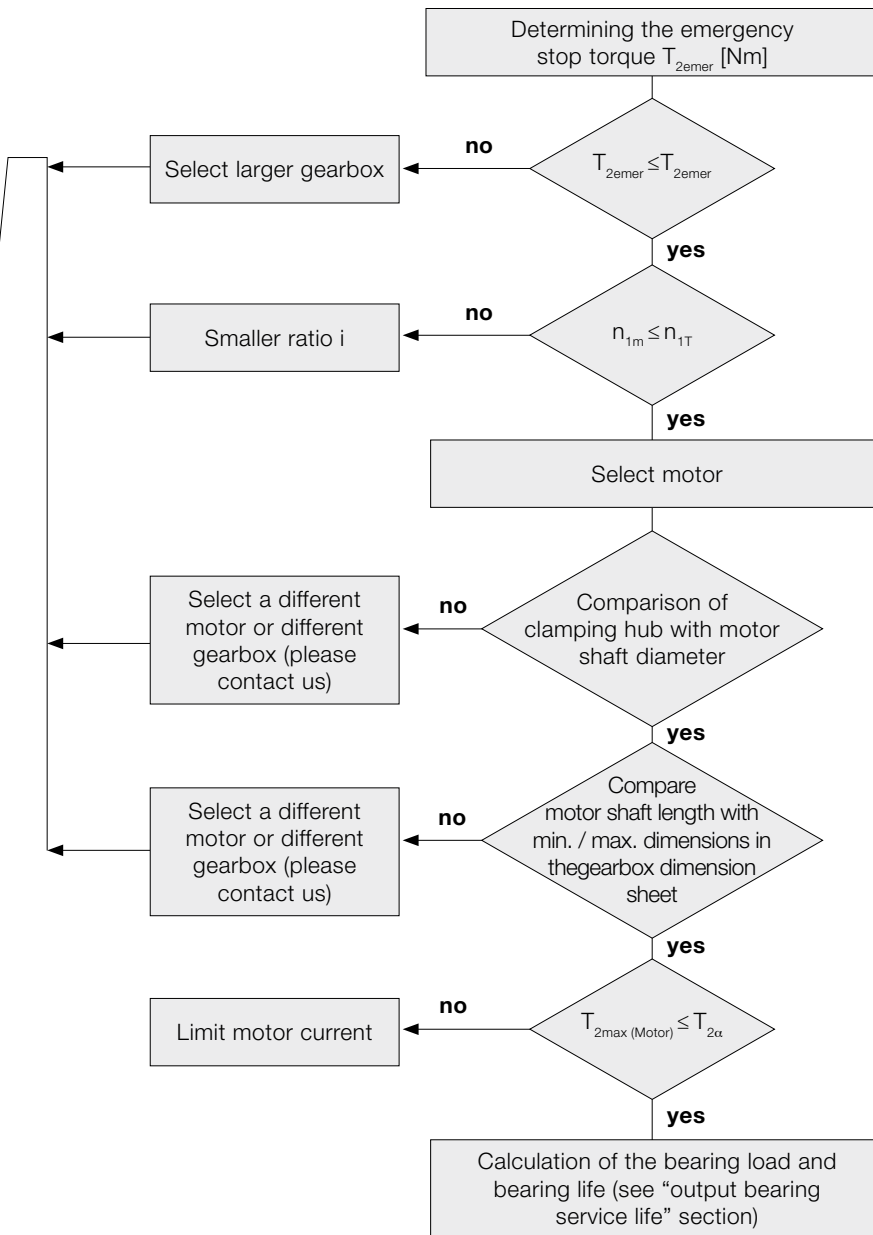

See glossary: T_{2emer}

$$n_{1m} = \frac{|n_{1,0}| \cdot t_0 + \dots + |n_{1,n}| \cdot t_n}{t_0 + \dots + t_n}$$

with $\sum_0^n t_n \leq 20$ min incl. pause time

Must be observed for any 20-minute period

$$\frac{D_{clamping\ hub}}{2} \leq D_{W, Mot} \leq D_{clamping\ hub}$$

It must be possible to insert the motor shaft into the clamping hub.

The motor shaft must protrude far enough into the clamping hub without hitting the backstop.

The gearbox must not be damaged when the motor is at full load; limit the motor current if necessary.

$$T_{2\ Mot\ max} = T_{1\ Mot\ max} \cdot i \cdot \frac{1}{\eta_{gearbox}} + T_{012}$$

Diagram 1
Usual load duty cycle at the output. At drive speeds up to the nominal speed n_{1n} or thermal speed limit n_{1T} , the gearbox does not get hotter than 90°C in average environmental conditions.

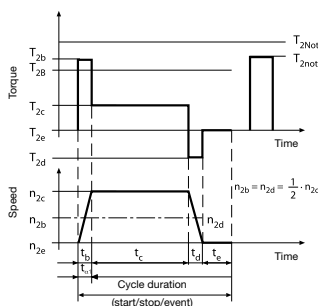

Diagram 2
High numbers of cycles in connection with shorter acceleration times can lead to oscillations in the drive train. The resulting excessive torque increases can be taken into consideration with the load factor f_s .

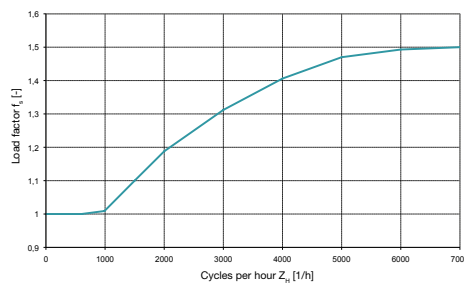
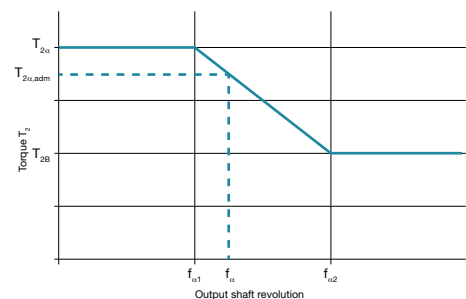

Diagram 3
The transmittable torque $T_{2u,adm}$ of the gearbox depends on the number of output shaft revolutions. In the range of low output shaft revolutions, the high cycle fatigue of the toothing can thus be utilized up to the maximum value $T_{2α}$.



Planetary/bevel gearbox – detailed sizing

Please use cymex® - www.wittenstein-cymex.com - for detailed sizing.

Output bearing service life L_{h10}

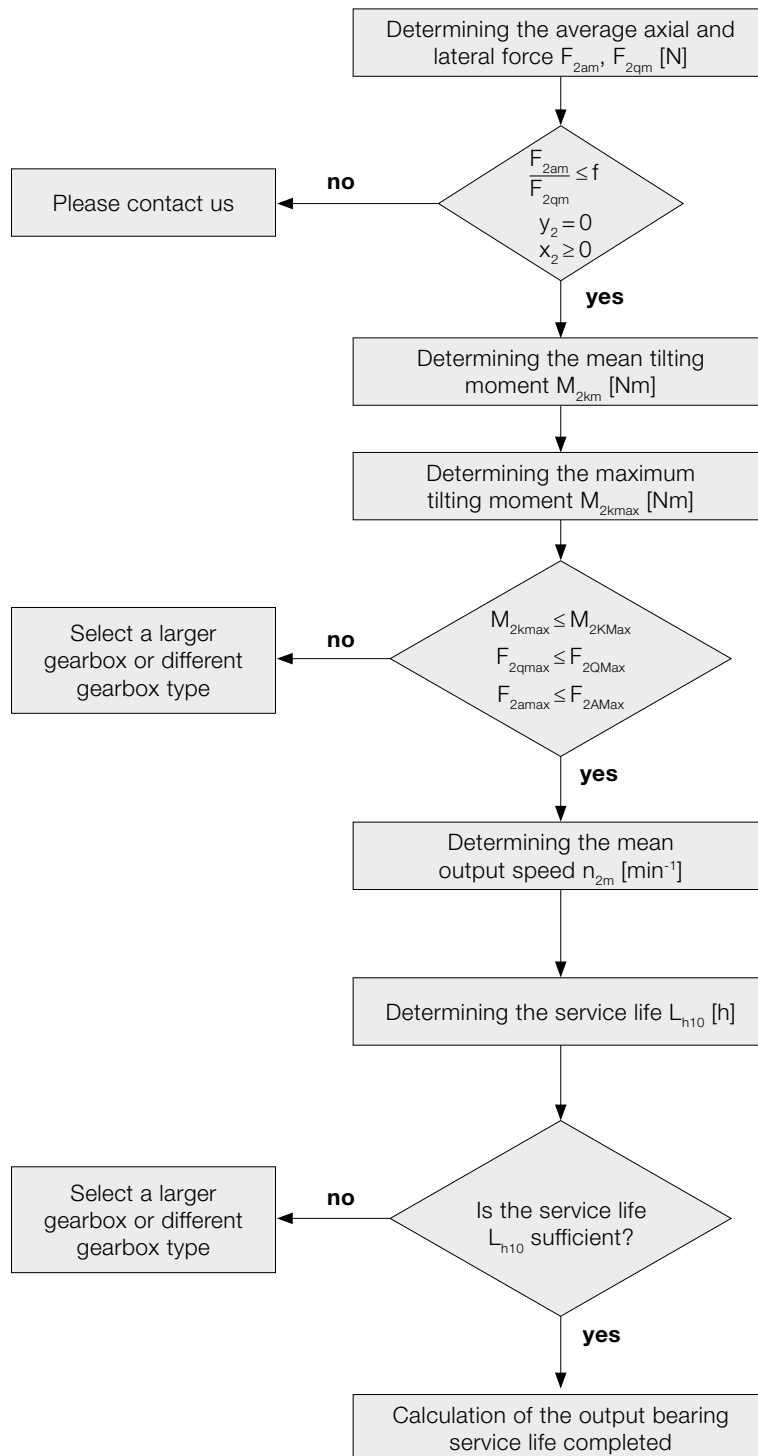

$$F_{2am} = \sqrt[3]{\frac{|n_{2b}| \cdot t_b \cdot |F_{2ab}|^3 + \dots + |n_{2n}| \cdot t_n \cdot |F_{2an}|^3}{|n_{2b}| \cdot t_b + \dots + |n_{2n}| \cdot t_n}}$$

$$F_{2qm} = \sqrt[3]{\frac{|n_{2b}| \cdot t_b \cdot |F_{2qb}|^3 + \dots + |n_{2n}| \cdot t_n \cdot |F_{2qn}|^3}{|n_{2b}| \cdot t_b + \dots + |n_{2n}| \cdot t_n}}$$

$$M_{2km} = \frac{F_{2am} \cdot y_2 + F_{2qm} \cdot (x_2 + z_2)^{a)}}{W}$$

$$M_{2kmax} = \frac{F_{2amax} \cdot y_2 + F_{2qmax} \cdot (x_2 + z_2)^{a)}}{W}$$

a) x, y, z in mm

$$n_{2m} = \frac{n_{2b} \cdot t_b + \dots + n_{2n} \cdot t_n}{t_b + \dots + t_n}$$

$$L_{h10} = \frac{16666}{n_{2m}} \cdot \left[\frac{K1_2}{M_{2km}} \right]^{p_2}$$

	metric
W	1000

	CP / CPS / NP / NPT / HDV CPK / CPSK / NPK / NPTK	NPL / NPS / NPR / NTP NPLK / NPSK / NPRK
f	0.24	0.4

CP / CPS CPK / CPSK			005	015	025	035	045
MF	Z ₂	[mm]	12.4	19.3	27.7	31.5	47
		[in]	0.49	0.76	1.1	1.2	1.9
	K _{1,2}	[Nm]	20	69	238	501	1512
		[in.lb]	177	610	2106	4433	13381
	P ₂		3	3	3	3	3

NP / NPK			005	015	025	035	045
MF / MA	Z ₂	[mm]	20	28.5	31	40	47
		[in]	0.79	1.1	1.2	1.6	1.9
	K _{1,2}	[Nm]	75	252	314	876	1728
		[in.lb]	663	2230	2778	7752	15292
	P ₂		3	3	3	3	3

NPT / NPTK			005	015	025	035	045
MF / MA	Z ₂	[mm]	27.7	34.6	39.3	44.5	58.2
		[in]	1.1	1.4	1.6	1.8	2.3
	K _{1,2}	[Nm]	136	211	310	628	995
		[in.lb]	1203	1867	2743	5557	8805
	P ₂		3	3	3	3	3

NPL / NPS / NPR NPLK / NPSK / NPRK			015	025	035	045
MF / MA	Z ₂	[mm]	42.2	44.8	50.5	63
		[in]	1.7	1.8	2	2.5
	K _{1,2}	[Nm]	795	1109	1894	3854
		[in.lb]	7035	9814	16761	34107
	P ₂		3.33	3.33	3.33	3.33

Example with output shaft and flange:

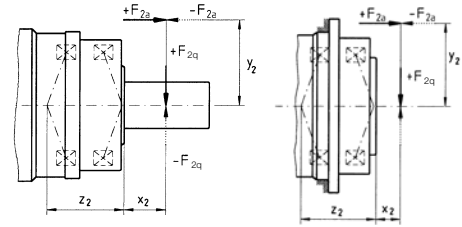

NTP			015	025	035	045
MQ	Z ₂	[mm]	51.6	73.7	85	69.7
		[in]	2.0	2.9	3.3	2.7
	K _{1,2}	[Nm]	490	1237	1809	3046
		[in]	4337	10947	16010	26957
	P ₂		3.33	3.33	3.33	3.33

HDV			015	025	035
MF	Z ₂	[mm]	41.7	45.65	57.25
		[in]	1.6	1.8	2.3
	K _{1,2}	[Nm]	84	131	406
		[in.lb]	743	1159	3593
MT	Z ₂	[mm]	53	58.65	74.75
		[in]	2.1	2.3	2.9
	K _{1,2}	[Nm]	217	452	1370
		[in.lb]	1920	4000	12125
	P ₂		3	3	3

Calculation tilting moment caused by the motor M_{1kMot}

For NPK, NPSK, NPLK, NPRK, NPTK, CPK, and CPSK

Particularly when the motor is installed in a horizontal mounting position (xx/B5)

Clamping hub diameter	-	mm	11	14	19	28	38
Max. permissible static tilting moment caused by motor	M_{1kMot}	Nm	5.5	7	18	55	130

In horizontal mounting position B5 and symmetrical weight distribution of the motor:

$$M_{1kMot} = \text{motor weight [kg]} \cdot 4,9 \cdot \text{motor length [m]}$$

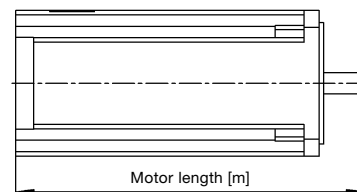

Sizing – Worm gearboxes

The following schematic shows the steps of the sizing of worm gearboxes.
Please use cymex® - www.wittenstein-cymex.com for a detailed sizing.

A: Simplified sizing for servo motors based on the maximum motor torque: $M_{max} * i \leq T_{2\alpha}$

B: Sizing based on the application

Step 1:

Determine the application data

$$T_{2b} = \text{_____ [Nm]} \quad n_{1n} = \text{_____ [rpm]}$$

Step 2:

Determine the operating mode factor $K_M = \text{_____}$

Typical applications	Cycle	Torque characteristic	Operating mode factor K_M
Format changing, e.g. in packaging machines, drives for processing equipment, actuators etc.	S5 operation: Low duty cycle Small number of cycles Low dynamics		1.0
Tool changers with low dynamics, pick & place gantry axes, tire building machines etc.	S5 operation: Medium duty cycle Small number of cycles Medium dynamics		1.6
Linear axes in plasma, laser or water jet cutters, portals, tool changers with high dynamics	S5 operation: Medium duty cycle Medium number of cycles High dynamics		1.9
Roller drives in printing presses, star drives in rackers etc.	S1 operation: High duty cycle		2.2

cymex® 5 also allows sizing calculations for other applications / cycles!

Step 3:

Determine the sizing factor f_a with the operating mode factor K_M $f_a = \text{_____}$

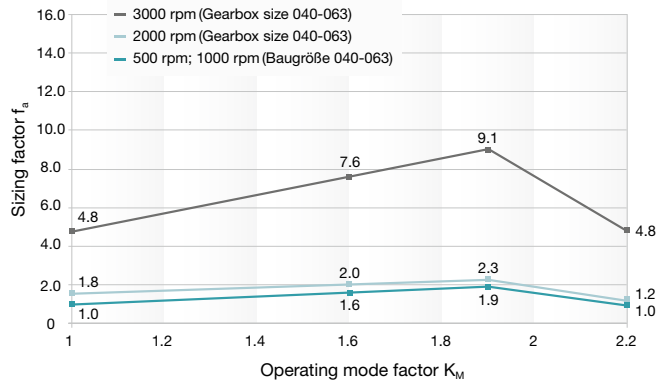

Step 4:

Compare the equivalent application torque with the maximum gearbox $T_{2\alpha}$ (see table, Step 5)

$$T_{2,eq} = f_a * T_{2b} \leq T_{2\alpha}$$

$$T_{2,eq} = \text{_____} * \text{_____} \leq T_{2\alpha}$$

$$T_{2,eq} = \text{_____ [Nm]} \leq \text{_____ [Nm]}$$

We recommend using a vent screw for duty cycles $\geq 60\%$, longer than 20 min (S1 operation) and $n1N \geq 3000$ rpm.

Step 5: Quick selection of the technical data

			V-Drive Basic			V-Drive Value		
			040	050	063	040	050	063
Ratio	i		7-40			4-400		
Max. torque ^{a)} (at $n_1 = 500$ rpm)	T_{2b}	Nm	68-82	116-140	265-301	74-98	150-167	303-365
Max. input speed	n_{1max}	rpm	6000	6000	4500	6000	6000	4500
Max. lateral force	F_{2QMmax}	N	1000 / 2400 ^{b)}	1200 / 3800 ^{b)}	2000 / 6000 ^{b)}	2400	3800	6000
Operating noise	L_{pA}	dB(A)	≤ 54	≤ 62	≤ 64	≤ 54	≤ 62	≤ 64
Max. backlash	j_1	arcmin	≤ 15	≤ 15	≤ 15	≤ 6	≤ 6	≤ 6
Service life	L_n	h	> 15000	> 15000	> 15000	> 20000	> 20000	> 20000

^{a)} The maximum torques depend on the ratio.

^{b)} Refers to center of the output shaft or flange. First value for MF-version (Standard), second value for MT-version (reinforced bearing).

Account must be taken of the lateral and axial forces at the output:

Please also carry out steps 6 and 7 if forces are present at the output (e.g. if timing belt pulleys, pinions or levers are mounted there).

Step 6 (if external forces are present):

Determine the forces acting on the output and check the boundary conditions

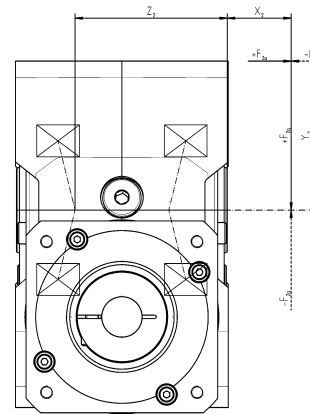

Lateral force $F_{2q} = \underline{\hspace{2cm}}$ [N]
 Lateral force distance $x_2 = \underline{\hspace{2cm}}$ [mm]
 Axial force $F_{2a} = \underline{\hspace{2cm}}$ [N]
 Axial force distance $y_2 = \underline{\hspace{2cm}}$ [mm]
 (required if F_{2a} is present)

Conditions if axial force F_{2a} is present:

1. $F_{2a} \leq 0.25 * F_{2q} \Rightarrow (\underline{\hspace{2cm}} \leq 0.25 * \underline{\hspace{2cm}})$ Met Not met: Sizing with cymex® 5
2. $y_2 \leq x_2 \Rightarrow (\underline{\hspace{2cm}} \leq \underline{\hspace{2cm}})$ Met Not met: Sizing with cymex® 5

Step 7:

Determine the maximum equivalent force acting on the output $F_{2,eq}$

$F_{2,eq} = F_{2q} + 0.25 * F_{2a} \leq F_{2QMax}$ (F_{2QMax} can be determined from the diagram below)

$F_{2,eq} = \underline{\hspace{2cm}} + 0.25 * \underline{\hspace{2cm}} \leq \underline{\hspace{2cm}}$

$F_{2,eq} = \underline{\hspace{2cm}}$ [N] \leq $\underline{\hspace{2cm}}$ [N] Met Not met: Sizing with cymex® 5

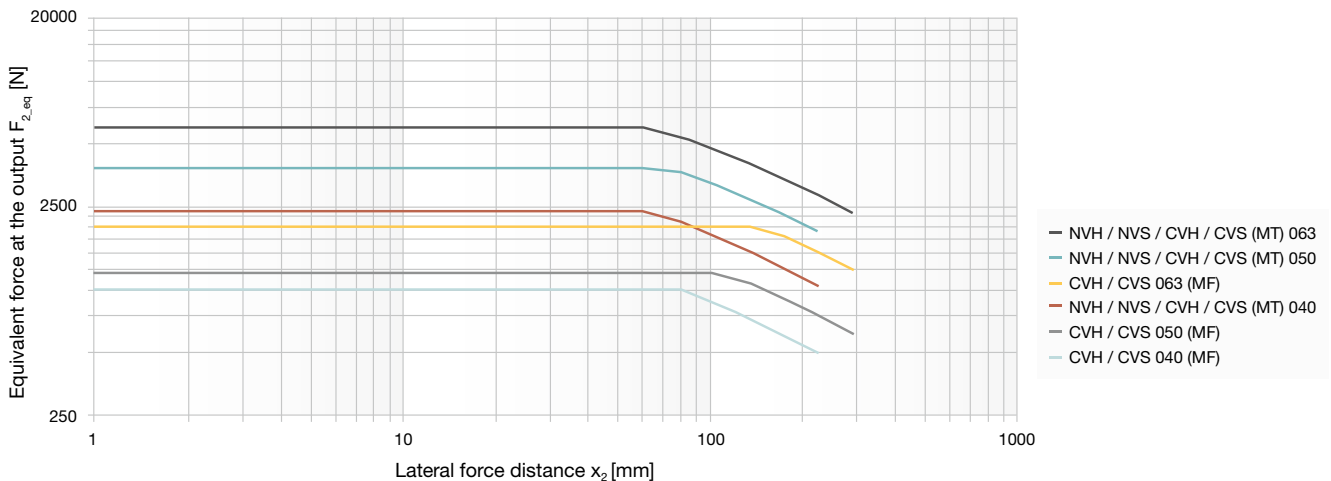

Glossary – the **alphabet**

Acceleration torque (T_{2B})

The acceleration torque T_{2B} is the torque that the gearbox toothing can permanently transmit. To calculate the acceleration torque, an \rightarrow **coefficient of impact** which is appropriate for the application must also be taken into account.

Adapter plate

WITTENSTEIN alpha uses a system of standardized adapter plates for connecting the motor and gearbox. This makes it as simple as possible to attach motors from any manufacturer to WITTENSTEIN alpha gearboxes.

Angle of rotation

Angle by which the connection element of the coupling rotates under the torque load. The admissible angle of rotation for torsionally rigid couplings is $< 0.05^\circ$ and for vibration-damping couplings $< 5^\circ$.

Angular minute

A degree is subdivided into 60 angular minutes (= 60 arcmin = $60'$).

Example:

If the backlash is $j_t = 1$ arcmin, the output may rotate by $1/60^\circ$. The impacts on the application are determined by the arc length: $b = 2 \cdot \pi \cdot r \cdot \alpha^\circ / 360^\circ$.

Example:

A pinion with a radius $r = 50$ mm mounted on a gearbox with a backlash of $j_t = 3$ arcmin can be rotated by $b = 0.04$ mm.

Angular misalignment

Angular misalignment of drive and output shaft. In most cases due to assembly. Causes an increased strain on the coupling.

Axial force (F_{2AMax})

An axial force on a gearbox runs parallel to its output shaft or perpendicular to its output flange. Under certain circumstances, it acts offset from the axis with a lever arm y_2 . In this case, it also creates a bending moment. If the axial force exceeds the permissible catalog values (max. axial force F_{2AMax}), an additional component (e.g. axial bearing) must be provided to absorb these forces.

Example with output shaft and flange:

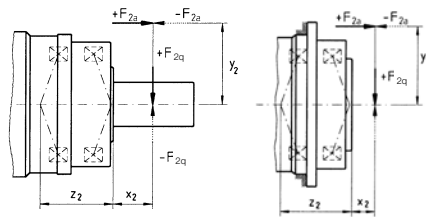

Axial misalignment

Length variation along the longitudinal axes of the drive and output shaft. Generally caused by thermal expansion.

Axial spring rigidity (C_a)

Counter-force of the coupling in the event of axial misalignment [N/mm]. This additional force should be taken into consideration in the sizing of the drive train and bearings.

Backlash-free

Changes in the rotational speed, direction of rotation or torque do not cause any backlash and thus no shocks in the coupling. However, it should be noted that an \rightarrow **angle of rotation** still occurs.

Bushing

If the diameter of the motor shaft is smaller than the \rightarrow **clamping hub**, a bushing is used to compensate for the difference in diameter. A minimum wall thickness of 1 mm and a motor shaft diameter of 2 mm difference are required.

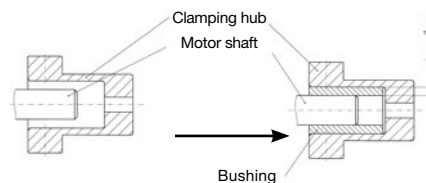

CAD POINT

Performance data, dimension sheets and CAD data for all gearboxes can be found online in our CAD POINT, including clear documentation of the selection. (www.wittenstein-cad-point.com)

Clamping hub (couplings)

The clamping hub ensures a friction contact connection between the coupling and the gearbox shaft as well as with the application. Clamping hubs are available in all motor shaft diameters; therefore, a bushing as connection piece is not required and also not recommended. Optionally, a form fit connection via a key is also possible.

Clamping hub (gearbox)

The clamping hub ensures a friction contact connection between the motor shaft and gearbox. If the diameter of the motor shaft is smaller than the diameter of the clamping hub, a \rightarrow **bushing** is used as a connection piece.

For gearboxes in the alpha Advanced Line and the alpha Premium Line, a form fit connection via a key is also possible.

Connection between the clamping hub and the metal bellows

For metal bellows couplings which transmit torques of up to 500 Nm, the stainless steel bellow is bonded onto the clamping hub. In the event of higher torques, the connection is welded.

Continuous operation (S1)

In continuous operation, it is particularly important to ensure that the maximum gearbox temperature is maintained (see temperature behavior). For optimum drive behavior in continuous operation, we recommend our HIGH SPEED gearbox model.

Cyclic operation (S5)

The cyclic operation is defined via the \rightarrow **duty cycle**. If the duty cycle is less than 60% and shorter than 20 minutes, it qualifies as cyclic operation (\rightarrow **operating modes**).

cymex®

cymex® is the calculation software developed by our company for dimensioning complete drive trains. The software enables the precise simulation of motion and load variables. The software is available to download from our website (www.wittenstein-cymex.de). We can also provide training to enable you to make full use of all the possibilities provided by the software.

cymex® select

The cymex® select quick layout tool from WITTENSTEIN alpha allows for efficient and innovative product selection in seconds and is available online.

You get suitable recommendations for your application and your motor in no time based on technical and economic suitability. (cymex-select.wittenstein-group.com)

Degrees of protection (IP)

The various degrees of protection are defined in DIN EN 60529 “Degrees of protection offered by enclosures (IP code)”. The IP degree of protection (International Protection) is represented by two digits. The first digit indicates the protection against the ingress of impurities and the second is the protection against the ingress of water.

Example:

IP65

Protection against the ingress of dust (dust-proofness)

Protection against water jets

Disengagement torque (T_{Dis})

Adjustable torque of torque limiters with which the coupling separates the drive and output side of the system.

Duty cycle (DC)

The cycle determines the duty cycle (DC). The times for acceleration (t_b), constant travel if applicable (t_c) and deceleration (t_d) combined yield the duty cycle in minutes.

The duty cycle is expressed as a percentage with inclusion of the dwell time t_e .

$$DC [\%] = \frac{t_b + t_c + t_d}{t_b + t_c + t_d + t_e} \cdot 100 \quad \frac{\text{Motion duration}}{\text{Cycle time}}$$

$$DC [\text{min}] = t_b + t_c + t_d$$

Dynamic torsional rigidity (C_{Tdyn})

Torsional rigidity with T_N

Efficiency (η)

The efficiency [%] η is the ratio of output power to input power. Power lost through friction reduces efficiency to less than 1 or 100%.

$$\eta = P_{\text{off}} / P_{\text{on}} = (P_{\text{on}} - P_{\text{loss}}) / P_{\text{on}}$$

Sample curve of the efficiency factor of a planetary gear depending on the torque

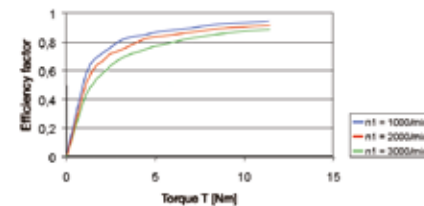

WITTENSTEIN alpha always indicates the efficiency of a gearbox during operation at full load. If the input power or torque is lower, the efficiency rating is also lower due to the constant no-load torque. Power losses do not increase as a result. A lower efficiency is also to be expected at high speeds (see figure).

Emergency stop torque (T_{2Emer})

The emergency stop torque T_{2Emer} is the maximum permissible torque at the gearbox output. It must not be reached more than 1000 times during the service life of the gearbox. It must never be exceeded! The following cases in particular should be checked: controlled emergency stop, power failure, brake application, and crash.



Ex symbol

Devices bearing the Ex symbol comply with EU Directive 94 / 9 / EC (ATEX) and are approved for use in defined explosion-hazardous zones.

Detailed information on the explosion group and category, as well as further information on the respective gearbox, is available upon request.

Food-grade lubrication (F)

These products are designed with food-grade lubrication and can therefore be used in the food industry. It is important to note the reduction in torque compared to the standard. (V-Drive excluded). See cymex® 5 or the CAD POINT for the exact torques.

HIGH SPEED (MC)

The HIGH SPEED version of our gearbox has been specifically developed for applications in continuous operation at high input speeds. It is used, for example, in the printing and the packaging industry.

HIGH TORQUE (MA)

WITTENSTEIN alpha gearboxes are also available in a HIGH TORQUE version. These gearboxes are particularly suitable for applications requiring extremely high torques and maximum rigidity.

Hysteresis curve

The hysteresis is measured to determine the torsional rigidity of a gearbox. The result of this measurement is known as the hysteresis curve.

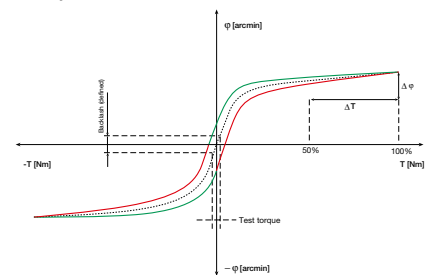

If the input shaft is locked, the gearbox is continuously loaded and relieved at the output in both directions of rotation up to a defined torque. The angle of rotation is plotted against the torque. This yields a closed curve from which the → **backlash** and → **torsional rigidity** can be calculated.

Jerk (j)

The jerk is the derivative of the acceleration with respect to time, that is, the change in acceleration in a unit of time. It is referred to as a shock if the acceleration curve shows a jump, i.e. the jerk is infinitely large.

Lateral force (F_{2QMax})

The maximum lateral force F_{2QMax} [N] is the force component that acts perpendicular to the output shaft or parallel to the output flange. It acts perpendicular to the → **axial force** and can have an axial distance x_2 to the shaft shoulder or to the shaft flange that acts as a lever arm. The lateral force creates a side load (also see → **axial force**).

→ Refer to this term for further details.

Glossary – the **alphabet**

Lateral misalignment

Parallel misalignment of the drive and output shaft. Causes an additional strain on the bearings and other components of the drive train.

Lateral spring rigidity (C_l)

Counter-force of the coupling in the event of lateral misalignment [N/mm]. This additional force should be taken into consideration in the sizing of the drive train and bearings.

Load factor (f_s) (gearbox)

The maximum admissible acceleration torque (T_{2B}) indicated in the catalog in cyclic operation applies to less than 1000 cycles/h. Greater numbers of cycles in connection with shorter acceleration times can lead to oscillations in the drive train. The resulting excessive torque increases are taken into consideration with the load factor f_s berücksichtigt.

WITTENSTEIN alpha suggests taking these unknown overloads into account using the following curve.

This determined value is multiplied by the actual acceleration torque T_{2b} before it is compared with the maximum permissible acceleration torque T_{2B} .

$$(T_{2b} \cdot f_s = T_{2b}', f_s < T_{2B})$$

The following applies to gearboxes:

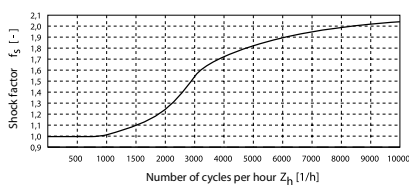

The following applies to couplings:

Number of cycles Z_h [1/h]	Metal bellow couplings and torque limiters	Elastomer couplings
< 1000	1.0	1.0
< 2000	1.1	1.2
< 3000	1.2	1.4
< 4000	1.8	1.8
> 4000	2.0	2.0

Mass moment of inertia (J)

The mass moment of inertia J [kg/cm²] is a measurement of the effort applied by an object to maintain its momentary condition (at rest or moving).

Maximum torque ($T_{2\alpha}$)

$T_{2\alpha}$ represents the maximum torque that can be transmitted by the gearbox. Depending on application-specific boundary conditions and the precise evaluation of the motion profile, the gearbox may be operated with a maximum torque $T_{2b,fs}$ above the specified maximum acceleration torque T_{2B} . (See diagram 3.) For detailed sizing, please use cymex cymex®

$$T_{2\alpha} \geq T_{2b,fs} \geq T_{2B}$$

No-load running torque (T_{012})

The no-load running torque T_{012} is the torque which must be applied to a gearbox in order to overcome the internal friction; it is therefore considered lost torque. The WITTENSTEIN alpha catalog values are determined at a speed $n_1 = 3.000 \text{ min}^{-1}$ and an ambient temperature of 20°C.

$$T_{012}: \quad 0 \quad \quad 1 \rightarrow 2$$

no load from input side toward
output side

No-load running torques decrease during operation.

NSF

Lubricants certified as grade H1 by the NSF (National Sanitation Foundation) can be used in the food sector where occasional unavoidable contact with food cannot be excluded.

Operating modes (continuous operation **S1** and cyclic operation **S5**)

Gearboxes are selected depending on whether the motion profile is characterized by frequent acceleration and deceleration phases in → **cyclic operation** (S5) as well as dwell times, or whether it is designed for → **continuous operation** (S1), i.e. with long phases of constant motion.

Operating noise (L_{PA})

The gear ratio and speed influence the operating noise. As a general rule, the higher the speed, the higher the operating noise and the higher the gear ratio, the lower the operating noise. Our catalog specifications refer to a reference gear ratio and speed. The reference speed is $n_1 = 3000 \text{ rpm}$ or $n_1 = 2000 \text{ rpm}$, depending on the size of the gearbox. Ratio-specific values can be found in cymex® - www.wittenstein-cymex.com

Output shaft revolution (f_α)

The factor f_α determines the number of service life cycles for the required service life of the gearbox. It describes the number of revolutions at the output to assess the permissible torque at the output.

Positioning accuracy

The positioning accuracy is determined by the angular deviation from the setpoint and is the sum of the load-dependent → **(torsional rigidity and torsional backlash)** and kinematic → **(synchronization)** angles of rotation that occur simultaneously in practice.

Quality control

All Premium and Advanced gearboxes at WITTENSTEIN alpha are subjected to an outgoing inspection before they leave the factory. This ensures that every gearbox is delivered within specification.

Ratio (i)

The ratio i indicates the factor by which the gearbox transforms the three relevant parameters of motion (speed, torque and mass moment of inertia).

The factor is a result of the geometry of the tooth elements (example.: $i = 10$).

$$n_1 = 3000 \text{ min}^{-1} \quad \begin{array}{l} \nearrow i \\ \searrow i \end{array} \quad \begin{array}{l} T_2 = 200 \text{ Nm} \\ n_2 = 300 \text{ min}^{-1} \end{array}$$

$$T_1 = 20 \text{ Nm} \quad \begin{array}{l} \nearrow i \\ \searrow i \end{array} \quad \begin{array}{l} J_1 = 0,10 \text{ kgm}^2 \\ J_2 = 10 \text{ kgm}^2 \end{array}$$

(Application)

Ratio of mass moment of inertia ($\lambda = \text{lambda}$)

The ratio of mass moment of inertia λ is the ratio of external inertia (application side) to internal inertia (motor and gearbox side). It is an important parameter determining the controllability of an application. Accurate control of dynamic processes becomes more difficult with increased differing mass moments of inertia and as λ becomes greater. WITTENSTEIN alpha recommends that a guideline value of $\lambda < 5$ is maintained. A gearbox reduces the external mass moment of inertia by a factor of $1/i^2$.

$$\lambda = \frac{J_{\text{external}}}{J_{\text{internal}}}$$

J'_{external} reduced to input:

$$J'_{\text{external}} = J_{\text{external}} / i^2$$

Simple applications ≤ 10
 Dynamic applications ≤ 5
 Highly dynamic applications ≤ 1

Safety instruction

For applications with special safety requirements (e.g. vertical axes, distorted gear inputs) we recommend exclusively employing our Premium and Advanced products (V-Drive excluded).

Servo actuators

In addition to a high-precision planetary gearbox, the servo actuator is equipped with a powerful, permanent magnet synchronous servo motor, which ensures high power density and a high speed stability thanks to the distributed winding. This enables even more compact and powerful linear drives to be realized. The investment costs for the drive train and the ongoing operating costs can be positively influenced by downsizing. The goal is to achieve a smaller input and therefore a smaller servo controller and lower energy consumption with the same productivity. A low mass moment of inertia combined with higher rigidity is the way to achieve this.

Shaft misalignment

One main function of the coupling is the compensation of the shaft misalignment which occurs in almost all applications between the drive and the output side. A distinction is made between \rightarrow axial, \rightarrow lateral- and \rightarrow angular misalignment. When complying with the indicated maximum misalignment, the couplings are safe for the duration of their service life.

Slipping torque

With a smaller clamping hub diameter, it is possible that the transmittable torque of the shaft-hub connection is lower than the maximum accelerating torque T_B of the coupling. In particular, this is applicable to the series BC3, BCT Standard, EL6 and ELC. More detailed information is available on request.

Speed (n)

The permitted maximum speed $n_{1\text{Max}}$ must be compared with the maximum speed $n_{1\text{max}}$ during operation. The maximum permissible speed $n_{1\text{Max}}$ must not be exceeded at any time.

The average speed n_{m} is determined as the arithmetic mean of the speeds in the cycle or over a maximum of 20 minutes. It must be below the permitted nominal speed n_{N} at all times. This applies to both cyclic and continuous operation.

$$n_{\text{m}} = \frac{|n_{1,0}| \cdot t_0 + \dots + |n_{1,n}| \cdot t_n}{t_0 + \dots + t_n} \text{ with } \sum_0^n t_n \leq 20 \text{min incl. pause time}$$

WITTENSTEIN alpha determines the thermal speed limit or thermal limit of the nominal speed in the laboratory at an ambient temperature of 20°C while maintaining a gearbox temperature of 90°C.

speedline® delivery

If required, standard series can be delivered within 24 or 48 hours ex works. Fast deliveries at short notice thanks to a high level of flexibility

Spring rigidity (C)

Counter-force of the coupling in the event of axial or lateral misalignment [N/mm]. A distinction is made between \rightarrow axial and \rightarrow lateral spring rigidity.

Static torsional rigidity (C_{Tstat})

Torsional rigidity at 50 % T_N

Synchronous run

The synchronous run refers to the measurable variation in speed between the input and output during one revolution of the output shaft. It is caused by manufacturing tolerances and results in ratio fluctuations within one revolution.

Technical data

Further technical data for our complete product portfolio is available to download from our website.

Temperature factor (f_t)

With elastomer couplings, the ambient temperature impacts the maximum admissible accelerating torque of the coupling. This is taken into consideration in the coupling design by means of the temperature factor f_t . The temperature factor depending on the elastomer insert used can be determined by means of the table.

Temperature °C	Elastomer insert			Metal bellows
	A	B	C	
> -30 to -10	1.5	1.3	1.4	1.0
> -10 to +30	1.0	1.0	1.0	1.0
> +30 to +40	1.2	1.1	1.3	1.0
> +40 to +60	1.4	1.3	1.5	1.0
> +60 to +80	1.7	1.5	1.8	1.0
> +80 to +100	2.0	1.8	2.1	1.0
> +100 to +120	-	2.4	-	1.0

\rightarrow Refer to this term for further details.

Glossary – the **alphabet**

Thermal behavior - temperature

It is necessary to measure the maximum temperature of the gearbox in the application.

The gearbox temperature is significantly influenced by the following application-specific factors:

- Load spectrum with nominal torque and nominal speed
- Motor temperature (e.g. heat input from the motor)
- Heat dissipation to the machine interface (e.g. mounting on a stainless steel structure or very thin mounting plates)
- Convection (e.g. convection prevented by installation location)
- Ambient temperature (e.g. excessively high ambient temperature of the air and the mechanical interface parts)

If the permissible gearbox temperature is exceeded, the service life of the gearbox is reduced considerably.

Tilting moment (M_{2k})

The tilting moment M_{2k} is a result of the **axial and lateral forces** applied and their respective force application points in relation to the inner radial bearing on the output side.

Tilting rigidity

The tilting rigidity C_{2k} of the gearbox is made up of the bending rigidity of the output or pinion shaft and the bearing stiffness of the output bearing. It is defined as a quotient of the tilting moment M_{2k} [Nm] and tilting angle Φ [arcmin] ($C_{2k} = M_{2k} / \Phi$).

Tooth engagement frequency (f_z)

In certain circumstances, the tooth engagement frequency can lead to vibration problems in the application, specifically if the excitation frequency corresponds to a natural frequency of the applications. For planetary gearboxes from WITTENSTEIN alpha (exception: gearboxes with ratio $i = 8$) the tooth engagement frequency can be calculated using the formula $f_z = 1,8 \cdot n_2$ [min⁻¹]. It is independent of the ratio in planetary gearboxes from Wittenstein alpha. If it does prove problematic, either the natural frequency of the system can be changed or a different gearbox (e.g. hypoid gearbox) with a different tooth engagement frequency can be chosen.

Torsional backlash (j_t)

Torsional backlash j_t [arcmin] describes the maximum angle of rotation of the output shaft in relation to the input. In simple terms, the torsional backlash describes the distance between two tooth flanks.

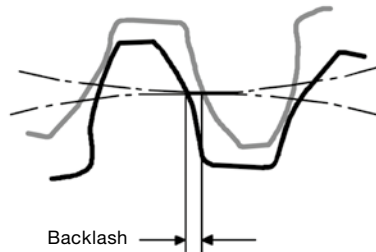

The measurement is taken with the input shaft blocked.

The output is then loaded with a defined test torque in order to overcome the internal gearbox friction. The main influence of the backlash is the flank backlash between the teeth. The low torsional backlash of the WITTENSTEIN alpha gearbox is achieved through high manufacturing precision and selective combination of the toothed wheels.

Torsional rigidity (C_{t21}) (gearbox)

The torsional rigidity [Nm/arcmin] C_{t21} is defined as the quotient of applied torque and resulting angle of rotation ($C_{t21} = \Delta T / \Delta \Phi$). It indicates the torque required to turn the output shaft by one angular minute. The torsional rigidity can be determined using the **hysteresis curve** Torsional rigidity C , angle of rotation Φ

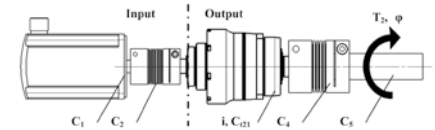

Reduce all torsional rigidity to the output:

$$C_{(n),ab} = C_{(n),an} \cdot i^2$$

with i = gearbox ratio [-]

$C_{(n)}$ = Individual rigidities [Nm/arcmin]

Note: The torsional rigidity C_{t21} for the gearbox always relates to the output.

Series connection of torsional rigidities

$$1/C_{ges} = 1/C_{1,ab} + 1/C_{2,ab} + \dots + 1/C_{(n)}$$

Angle of rotation Φ [arcmin]

$$\Phi = T_2 \cdot 1/C_{ges}$$

with T_2 = output torque [Nm]

Torsional rigidity (C_t) (couplings)

The torsional rigidity [Nm/arcmin] C_t is defined as the quotient of applied torque and resulting angle of rotation. It shows the torque required to turn the two clamping hubs against each other by one angular minute. If the maximum value is exceeded, the coupling can no longer transmit the applied torque since the **angle of rotation** of the coupling becomes too large. A distinction is made between **static** and **dynamic torsional rigidity**.

Torque ($T_{2\alpha}$)

$T_{2\alpha}$ represents the maximum torque that can be transmitted by the gearbox. This value may be reduced depending on application-specific boundary conditions and the precise evaluation of the motion profile.

→ Refer to this term for further details.



Glossary – Formulae

Formulae

Torque [Nm]	$T = J \cdot \alpha$	J = Mass moment of inertia [kgm ²] α = Angular acceleration [1/s ²]
Torque [Nm]	$T = F \cdot l$	F = Force [N] l = Lever, length [m]
Acceleration force [N]	$F_b = m \cdot a$	m = Mass [kg] a = Linear acceleration [m/s ²]
Frictional force [N]	$F_{\text{Reib}} = m \cdot g \cdot \mu$	g = Acceleration due to gravity 9.81 m/s ² μ = Coefficient of friction
Angular speed [1/s]	$\omega = 2 \cdot \pi \cdot n / 60$	n = Speed [rpm] π = PI = 3.14...
Linear speed [m/s]	$v = \omega \cdot r$	v = Linear speed [m/s] r = Radius [m]
Linear speed [m/s] (spindle)	$v_{\text{sp}} = \omega \cdot h / (2 \cdot \pi)$	h = Screw pitch [m]
Linear acceleration [m/s²]	$a = v / t_b$	t_b = Acceleration time [s]
Angular acceleration [1/s²]	$\alpha = \omega / t_b$	
Pinion path [mm]	$s = m_n \cdot z \cdot \pi / \cos \beta$	m_n = Normal module [mm] z = Number of teeth [-] β = Helix angle [°]

Conversion table

1 mm	= 0.039 in
1 Nm	= 8.85 in.lb
1 kgcm²	= 8.85 x 10 ⁻⁴ in.lb.s ²
1 N	= 0.225 lb _f
1 kg	= 2.21 lb _m

Symbol

Symbol	Unit	Designation
C	Nm/arcmin	Stiffness
ED	%, min	Duty cycle
F	N	Force
f_s	–	Load factor
f_e	–	Factor for duty cycle
i	–	Ratio
j	arcmin	Backlash
J	kgm ²	Mass moment of inertia
$K1$	Nm	Factor for bearing calculation
L	h	Service life
L_{PA}	dB(A)	Operating noise
m	kg	Mass
M	Nm	Torque
n	rpm	Speed
p	–	Exponent for bearing calculation
η	%	Efficiency
t	s	Time
T	Nm	Torque
v	m/min	Linear speed
z	1/h	Number of cycles

Index

Index	Designation
Capital letter	Permissible values
Small letter	Actual values
1	Input
2	Output
A/a	Axial
B/b	Acceleration
c	Constant
d	Deceleration
e	Pause
h	Hours
K/k	Tilting
m	Mean
Max/max	Maximum
Mot	Motor
N	Nominal
Not/not	Emergency stop
0	No load
Q/q	Lateral
t	Torsional
T	Tangential

Ordering code – planetary gearboxes

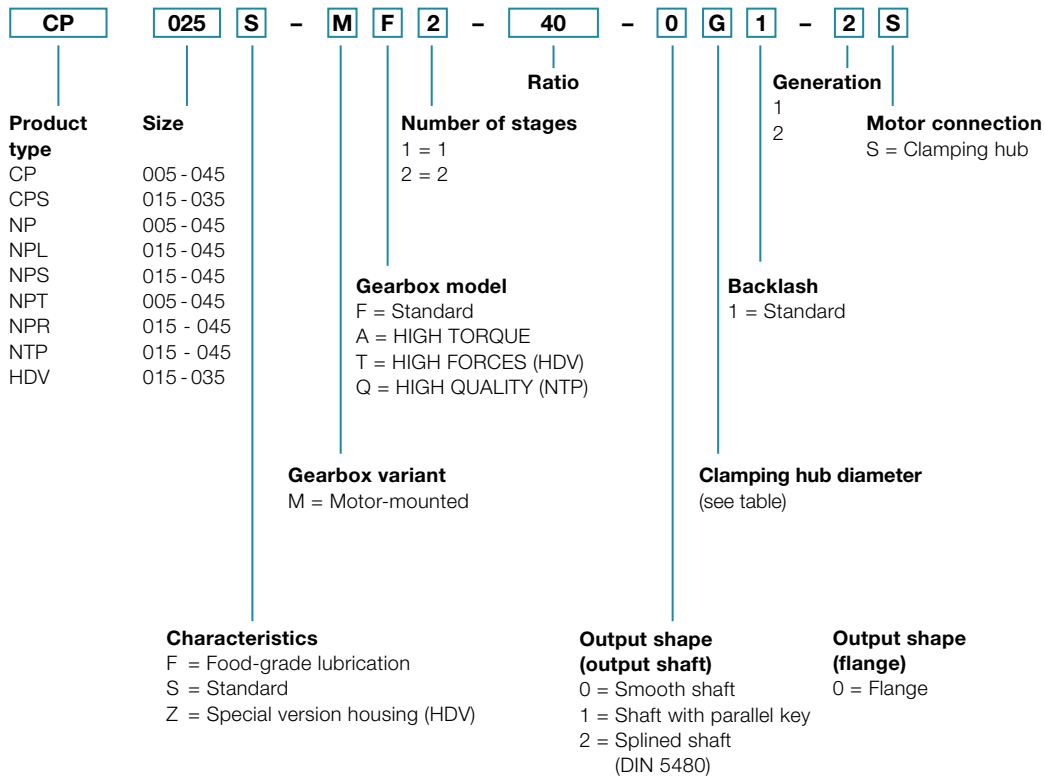

Mounting positions and clamping hub diameters

Clamping hub diameter
 (see technical data sheet for possible diameters)

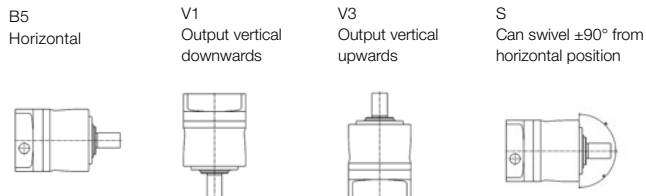

Code letter	mm	Code letter	mm
Z	8	E	19
A	9	G	24
B	11	H	28
C	14	I	32
D	16	K	38

For information purposes only – not required when placing orders!
 Please contact WITTENSTEIN alpha for deviating mounting positions.

Ordering code – bevel gearboxes

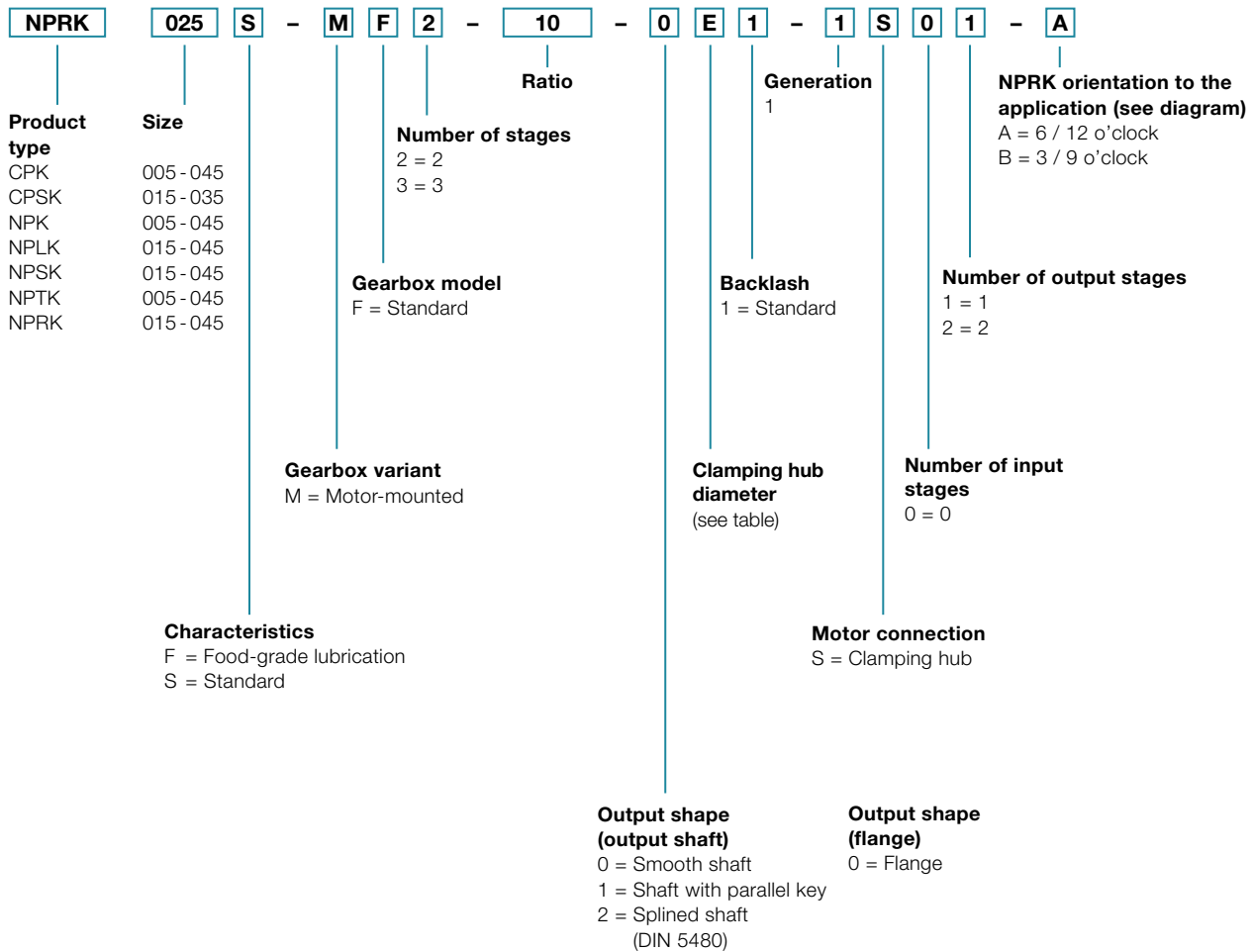

Mounting positions and clamping hub diameters

B5 / V3
 Output horizontal /
 motor shaft vertical upwards

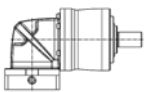

B5 / V1
 Output horizontal /
 motor shaft vertical downwards

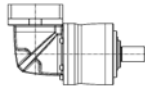

V1 / B5
 Output vertical downwards /
 motor shaft horizontal

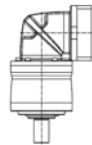

V3 / B5
 Output vertical upwards /
 motor shaft horizontal

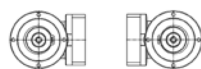
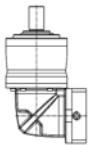

B5 / B5
 Output horizontal /
 motor shaft horizontal

Clamping hub diameter
 (see technical data sheet for possible diameters)

Code letter	mm
B	11
C	14
E	19
H	28
K	38

Orientation to the application

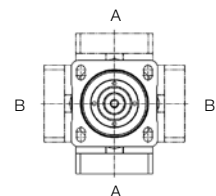

For information purposes only – not required when placing orders!
 Please contact WITTENSTEIN alpha for deviating mounting positions.

Ordering code – worm gearboxes

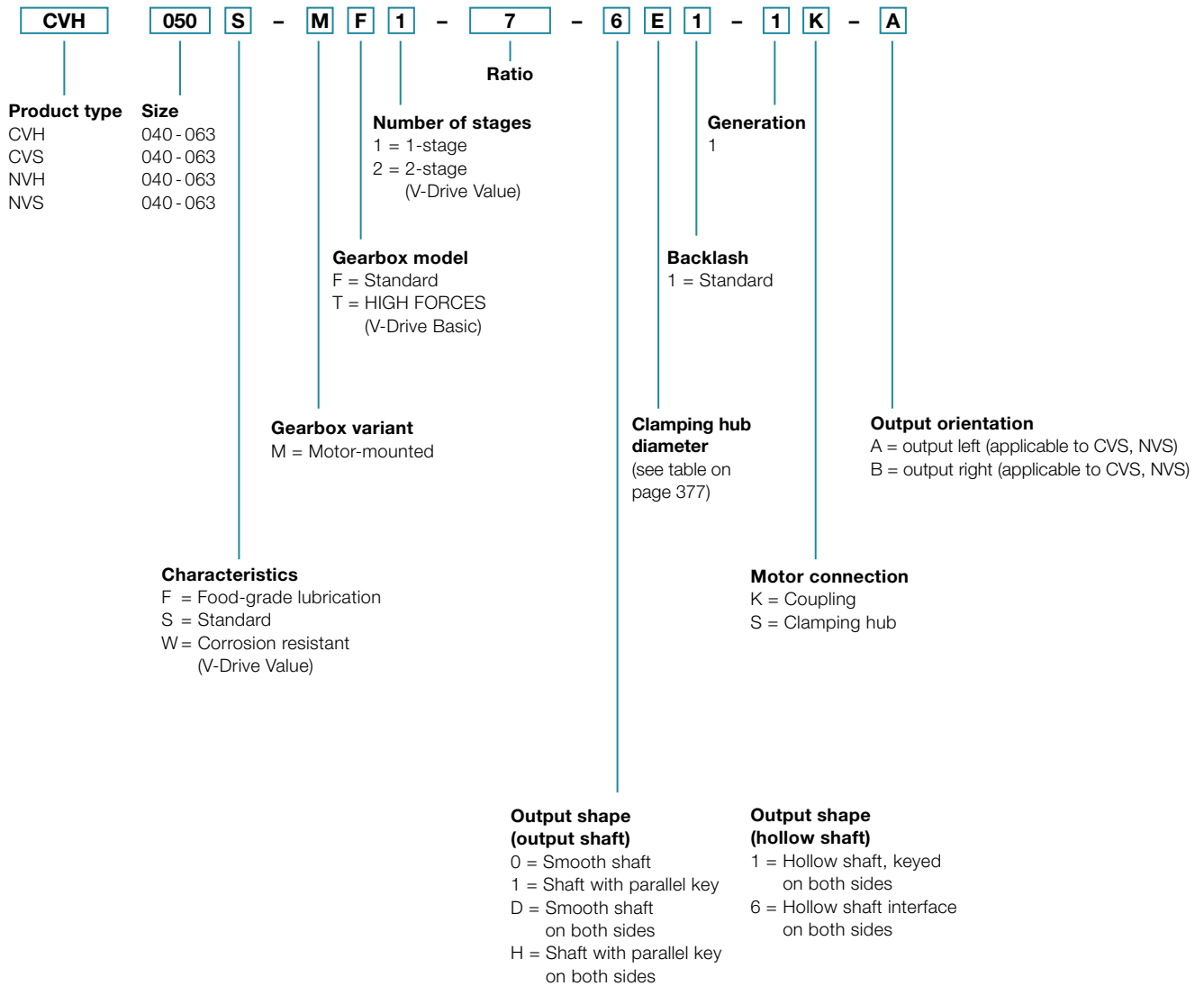

Mounting positions and clamping hub diameters

Output side A:
View of the motor connection,
output left
Only valid for CVS, NVS.

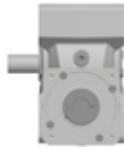

Output side B:
View of the motor connection,
output right
Only valid for CVS, NVS.

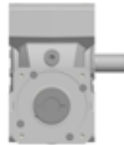

Installation position (only important for defining the bleed screw)

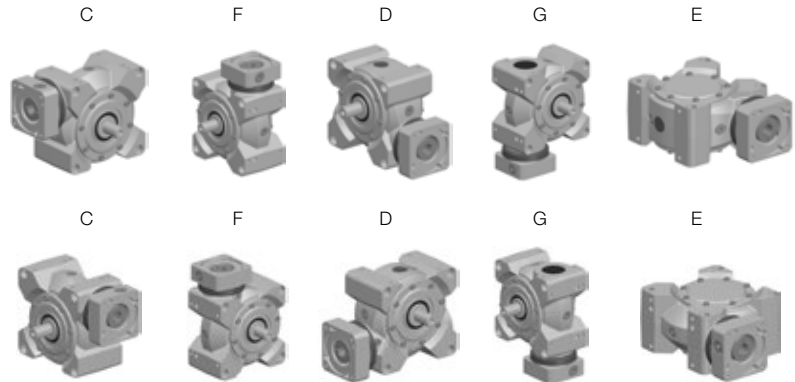

For V-Drives with dual shaft output or hollow shaft, the orientation of the output drive is not required.

Clamping hub diameter
(see technical data sheet for possible diameters)

Code letter	mm
C	14
E	19
G	24
H	28

Intermediate sizes possible using bushings
with a minimum wall thickness of 1 mm.



alpha

WITTENSTEIN alpha GmbH
Walter-Wittenstein-Straße 1
97999 Igersheim
Germany

Tel. +49 7931 493-0
24h-Service-Hotline: Tel. +49 7931 493-12900
speedline®: Tel. +49 7931 493-10444
info@wittenstein-alpha.com

Subject to technical changes. alpha Basic Line & alpha Value Line

WITTENSTEIN alpha – Intelligent drive systems

www.wittenstein-alpha.com

The entire world of drive technology – Catalogs available on request or online at www.wittenstein-alpha.com/download



alpha Premium Line. Unique, individual solutions that offer unparalleled power density.



alpha Advanced Line. Maximum power density and outstanding positioning accuracy for complex applications.



alpha Basic Line & alpha Value Line. Reliable, flexible and economical solutions for a wide range of applications.



alpha Linear Systems. Precise, dynamic system solutions for every requirement.



alpha Mechatronic Systems. Energy-efficient, versatile and flexible mechatronic drive systems.



alpha Accessories. Optimally designed and adapted for gearboxes and actuators.