

Bearings for Papermaking Machines

NSK bearings achieved the longer life and higher limiting speed under high-temperature conditions including moisture and dust environment such as papermaking machines and the productivity was enhanced dramatically.

**Choose
NSK**

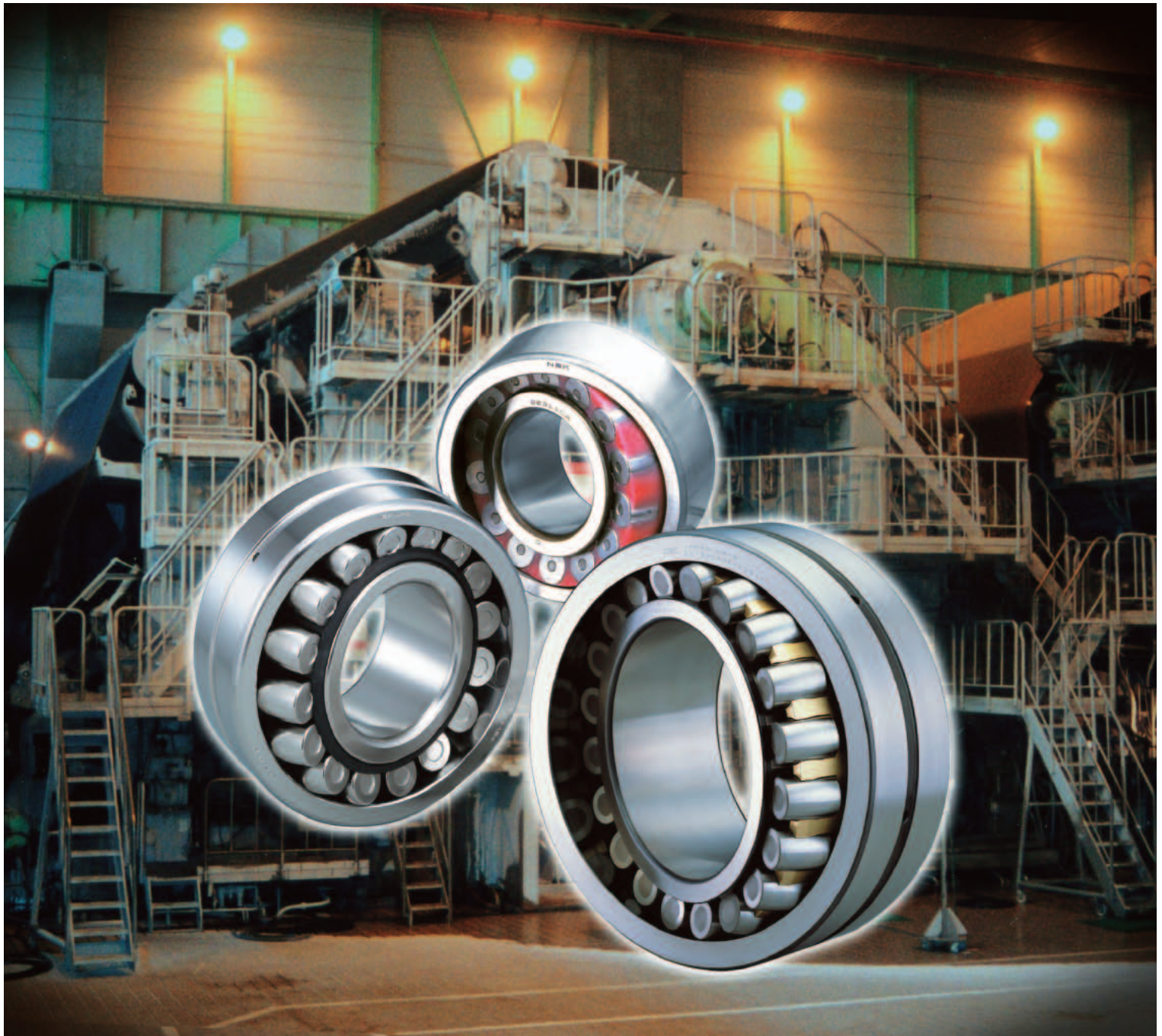

The NSK brand, recognized around the world

From home electric appliances, automobiles, and large-scale equipment to the aerospace industry—NSK bearings are used in an extensive range of fields. NSK established its global-scale enterprise on technology that has met the exacting requirements of Japanese industry. We have also established R&D systems and support services to meet the diverse needs of our customers throughout the world. As a brand recognized around the world, NSK continues to lead the industry with its technical prowess.



Solution Provider NSK

JAPAN	
Headquarters	1
Production site	22
Sales site	36
R&D center	6

THE AMERICAS		(Locations of bases)
Headquarters	1	U.S.A.
Production site	8	Canada
Sales site	20	Mexico
R&D center	2	Brazil
Representative office	1	Peru Argentina

EUROPE/AFRICA		(Locations of bases)
Headquarters	1	U.K.
Production site	9	Germany
Sales site	15	France
R&D center	3	Italy
Representative office	3	Spain Poland Russia Norway Turkey United Arab Emirates South Africa

ASIA / OCEANIA		(Locations of bases)
Headquarters	3	Singapore
Production site	25	Indonesia
Sales site	50	Thailand
R&D center	3	Malaysia
Representative office	3	Philippines Vietnam India Australia New Zealand China South Korea Taiwan

As of March 2013

The high quality and toughness of NSK bearings reduce maintenance costs in the papermaking industry.

Papermaking machine bearings operating under high-temperature conditions are vulnerable to problems such as fracturing of the inner ring, which can result in work stoppages. NSK bearings, with their long service life, superior resistance to inner ring fractures, outstanding hardness, and excellent dimensional stability under high temperatures, produce solutions for a host of paper mill applications and operating environments.

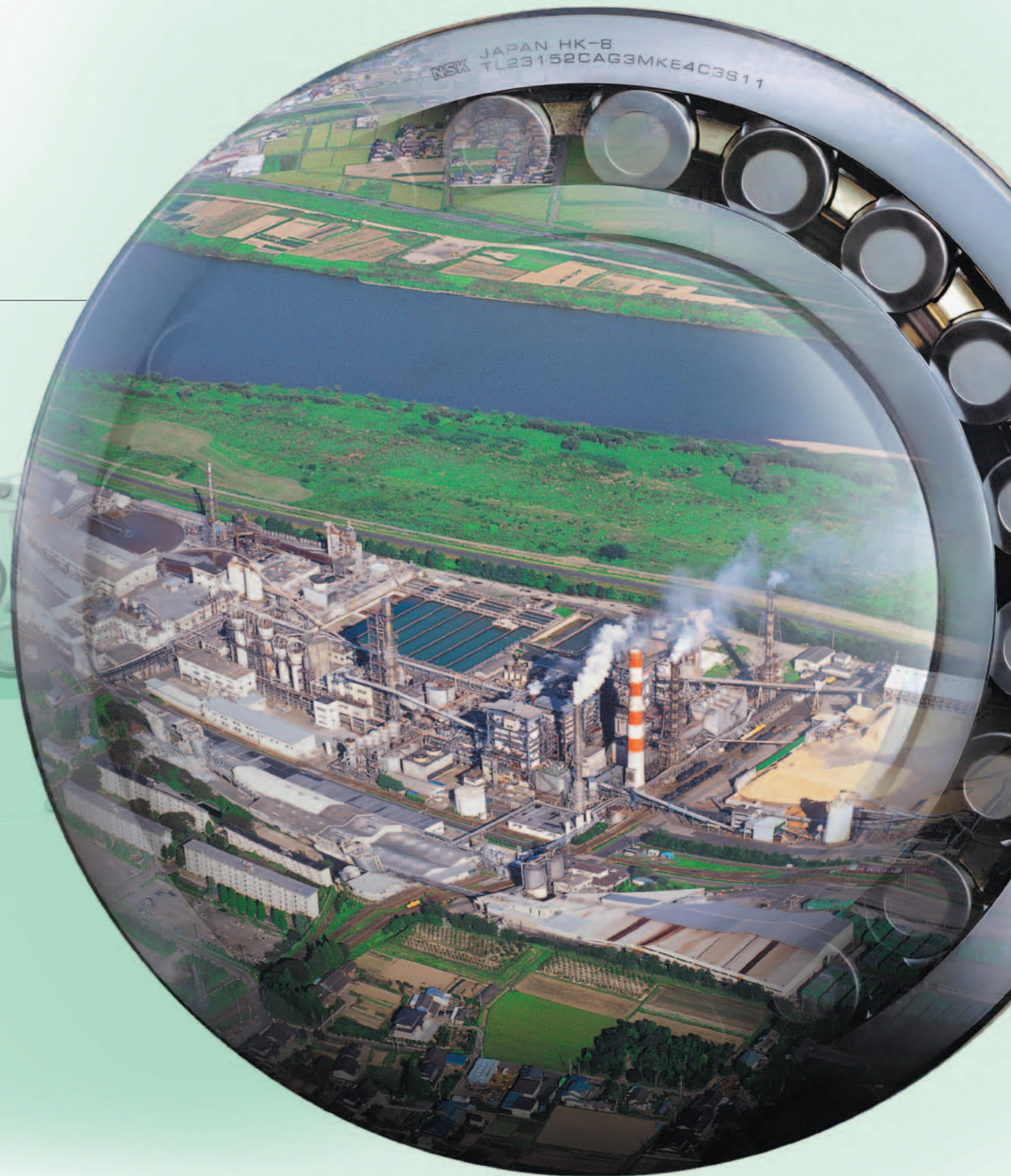

The Papermaking Process and Spherical Roller Bearing Specifications

Key to Bearing Specifications:

- ① Bearing type
SR: Spherical Roller Bearing
TR: Tapered Roller Bearing
B: Ball Bearing
- ② Bearing inner ring bore diameter
- ③ Bearing series
- ④ Internal clearance / tolerance class
- ⑤ Lubrication
- ⑥ Others

- ### Suction Couch Roll
- | Front | Back | Back-internal |
|-----------------------------------------------------------------------|----------------------------------------------------------------------|-------------------------------------------------------|
| ① SR
② 320-1000
③ 239, 230XX
④ C3 / P55
⑤ Oil circulation | ① SR
② 260-420
③ 230, 231XX
④ C3 / P55
⑤ Oil circulation | ① SR
② 100-200
③ 223XX
④ C3 / P0
⑤ Grease |

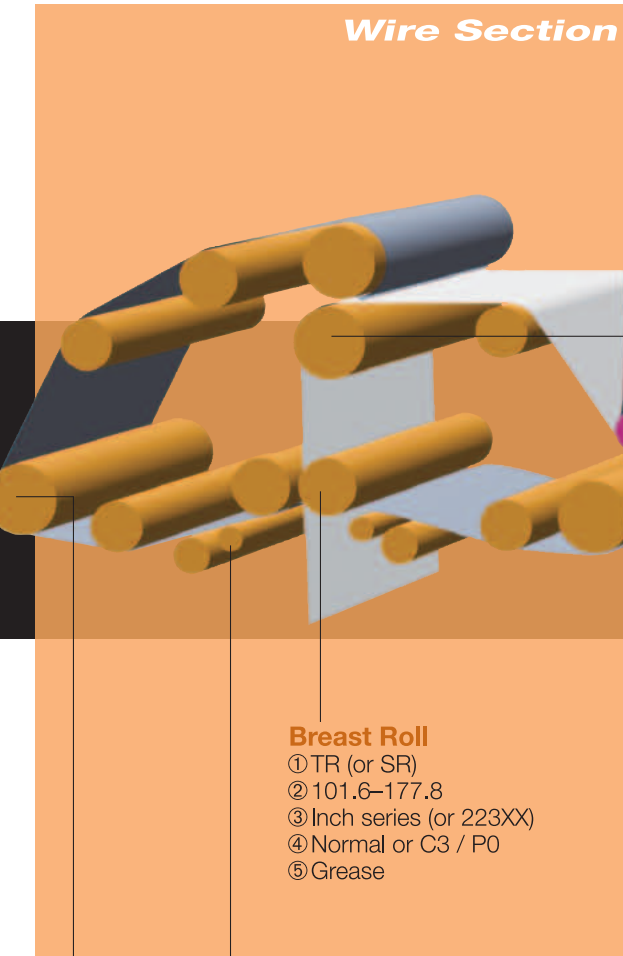

- ### Breast Roll
- ① TR (or SR)
 - ② 101.6-177.8
 - ③ Inch series (or 223XX)
 - ④ Normal or C3 / P0
 - ⑤ Grease

- ### Expander Roll
- ① B
 - ② 75-190
 - ③ 60, 62XX
 - ④ Special / P0
 - ⑤ Grease

- ### Turning Roll
- ① TR (or SR)
 - ② 101.6-177.8
 - ③ Inch series (or 223XX)
 - ④ Normal or C3 / P0
 - ⑤ Grease

- ### Felt Roll
- ① TR
 - ② 60.325-146.05
 - ③ Inch series
 - ④ Normal / P0
 - ⑤ Grease

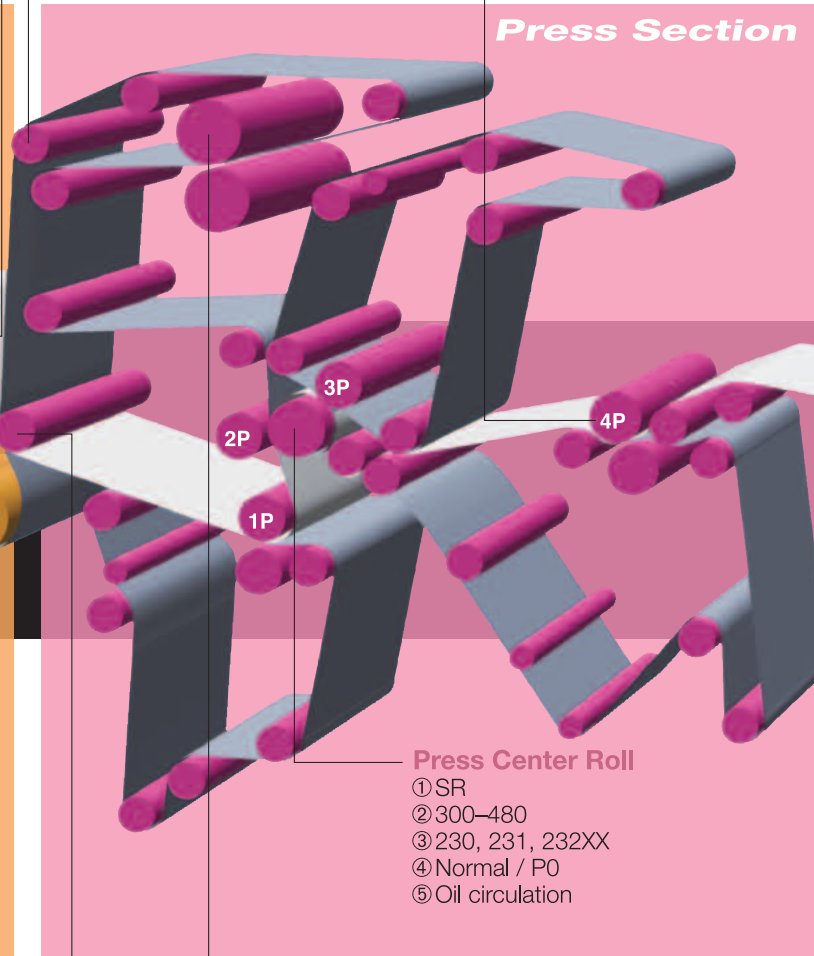

- ### Press Roll (1P-4P)
- ① SR
 - ② 300-480
 - ③ 230, 231, 232XX
 - ④ Normal / P0 or P55
 - ⑤ Grease or oil circulation
 - ⑥ CCR: Triple Ring Bearing

- ### Press Center Roll
- ① SR
 - ② 300-480
 - ③ 230, 231, 232XX
 - ④ Normal / P0
 - ⑤ Oil circulation

- ### Wringer Roll
- ① SR
 - ② 190-380
 - ③ 231, 232, 223XX
 - ④ Normal or C3 / P0
 - ⑤ Oil circulation

- ### Suction Pick-Up Roll
- | Front | Back | Back-internal |
|---------------------------------------------------------------------------|----------------------------------------------------------------------|-------------------------------------------------------|
| ① SR
② 320-480
③ 239, 230, 231XX
④ C3 / P55
⑤ Oil circulation | ① SR
② 260-400
③ 230, 231XX
④ C3 / P55
⑤ Oil circulation | ① SR
② 110-130
③ 232XX
④ C3 / P0
⑤ Grease |

- ### Canvas Roll
- ① SR
 - ② 50-110
 - ③ 223XX
 - ④ C3 / P0
 - ⑤ Oil circulation
 - ⑥ Heat treatment: TL or S11

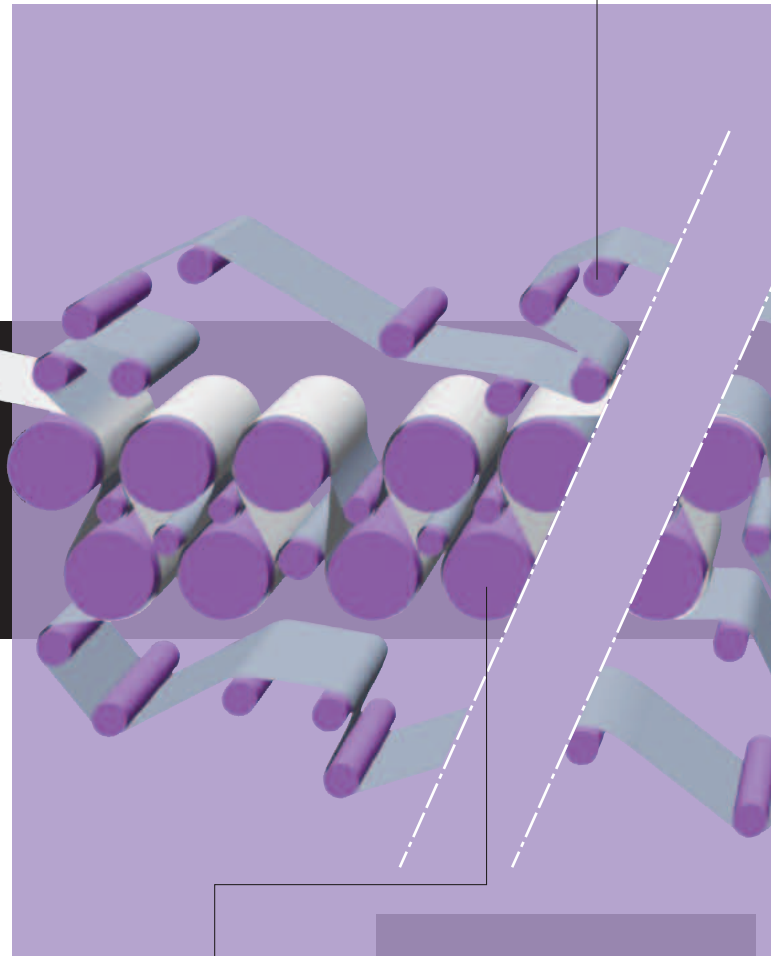

- ### Paper Roll
- ① SR
 - ② 50-70
 - ③ 223XX
 - ④ C3 / P0
 - ⑤ Oil circulation
 - ⑥ Heat treatment: TL or S11

- ### Breaker Stack Bottom Roll
- ① SR
 - ② 320
 - ③ 231XX
 - ④ C3 / P55
 - ⑤ Oil circulation
 - ⑥ Heat treatment: TL or S11

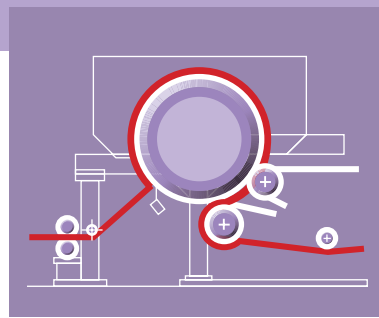

- ### Yankee Dryer
- ① SR
 - ② 400-600
 - ③ 230, 231XX
 - ④ C3 or C4 / P0
 - ⑤ Oil circulation
 - ⑥ Heat treatment: TL or S11 or carburized steel + S11

- ### Drying Cylinder
- ① SR
 - ② 160-300
 - ③ 230, 231, 222, 232XX
 - ④ C3 or C4 / P0
 - ⑤ Oil circulation
 - ⑥ Heat treatment: TL

- ### PV Roll
- ① SR
 - ② 90-380
 - ③ 239, 231, 222, 223XX
 - ④ C3 / P0
 - ⑤ Oil circulation
 - ⑥ Heat treatment: TL or S11

- ### Soft Calender
- ① SR
 - ② 400-600
 - ③ 232, 241XX
 - ④ C3 or C4 / P0 or P55
 - ⑤ Oil circulation
 - ⑥ Heat treatment: TL or S11 or carburized steel + S11

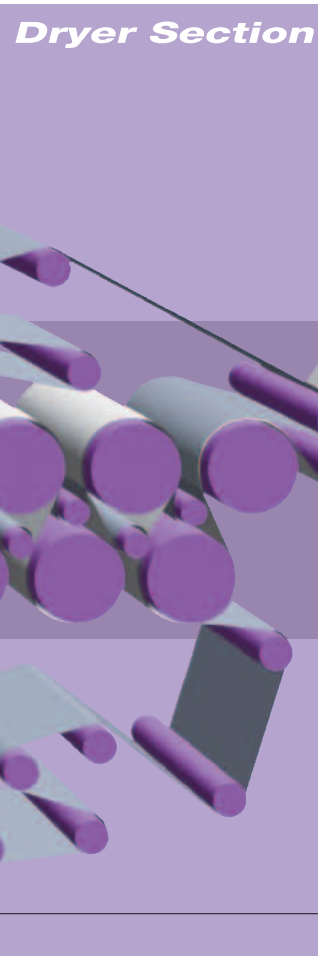
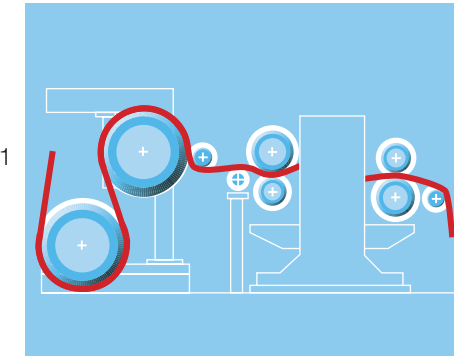

- ### Calender Queen Roll
- ① SR
 - ② 160-320
 - ③ 231XX
 - ④ C3 / P0
 - ⑤ Oil circulation

- ### Calender Bottom Roll
- ① SR
 - ② 240-530
 - ③ 232XX
 - ④ C3 / P0
 - ⑤ Oil circulation
 - CCR: Triple Ring Bearing

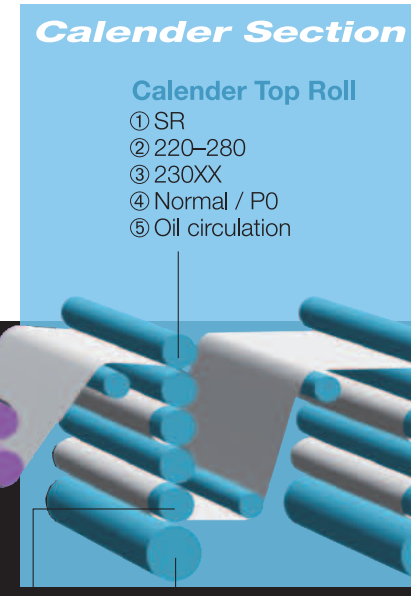

- ### Calender Top Roll
- ① SR
 - ② 220-280
 - ③ 230XX
 - ④ Normal / P0
 - ⑤ Oil circulation

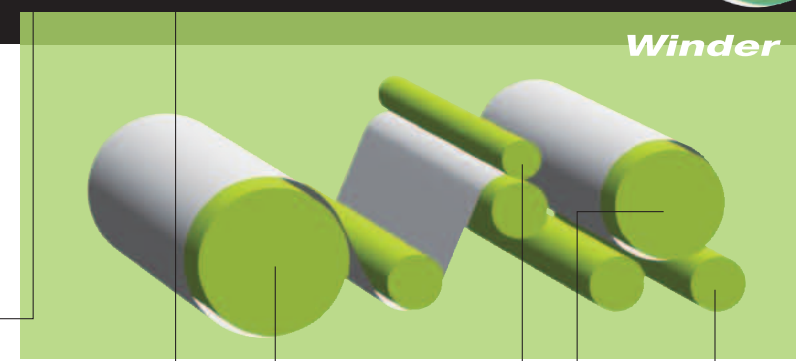

- ### Paper Roll
- ① SR
 - ② 60-95
 - ③ 223XX
 - ④ C3 / P6
 - ⑤ Oil bath or grease

- ### Unwinding Stand
- ① SR
 - ② 80-130
 - ③ 222XX
 - ④ C3 / P6 or P0
 - ⑤ Oil bath

- ### Reel Spreader Roll
- ① SR
 - ② 60-70
 - ③ 223XX
 - ④ Normal / P0
 - ⑤ Grease

- ### Reel Drum Roll
- ① SR
 - ② 190
 - ③ 222, 223XX
 - ④ C3 / P0
 - ⑤ Oil bath

- ### Reel Pool Roll
- ① TR
 - ② 130-180
 - ③ 322XX
 - ④ Normal / P0
 - ⑤ Grease

- ### Rider Roll
- ① SR
 - ② 60-80
 - ③ 222, 223XX
 - ④ C3 / P6
 - ⑤ Oil bath

- ### Winder Drum Roll
- ① SR
 - ② 130-160
 - ③ 223XX
 - ④ C3 / P6
 - ⑤ Oil bath

A Product Line that Matches Specific Applications



TL Series Spherical Roller Bearings
Ideal for high temperature equipment, with resistance to inner ring fracture. Tough, long-life TL bearings boost productivity and lower costs.
Major applications: dryer rolls, canvas rolls, PV rolls, and calender rolls



NSKHPS Spherical Roller Bearings
Next-generation standard bearings utilizing innovative materials and technologies benefit from NSK's experience and expertise to deliver longer life and higher limiting speed.
Major applications: small diameter rolls such as canvas rolls, paper rolls, felt rolls, and rider rolls



Molded-Oil™ Bearings
Excellent performance in environments exposed to moisture or paper dust, without oil leakage. Molded oil using an optimized molding method with optimal composition provides higher speed operation, is easy to handle, and safe for the environment.
Major applications: raw material conveyors, carrier rope sheaves, suction rolls



EM Series Cylindrical Roller Bearings
Bearings with integrated machined cages offer enhanced performance by combining the advantages of the conventional M series bearings and the high-load EMA1 series.
Major applications: motors and pumps



Triple Ring Bearings
Uniquely structured bearing for ease of use and no creep while offering high precision and long life.
Major applications: press rolls, breaker stack rolls



CA Series Spherical Roller Bearings
Superior radial load capacity and alignment, featuring high load capacity and excellent strength; equipped with a machined cage. This product lineup includes high running accuracy to ISO tolerance class 5.
Major applications: large diameter rolls such as suction rolls, press rolls, calender rolls and reel drum rolls.



Deep Groove Ball Bearings for High-Speed Expander Rolls
Special bearings that suppress friction torque and surface damage such as smearing and others.

NSK offers other advantageous products for various rolls and conveyors, including the HR series of high load capacity tapered roller bearings and easy-to-handle ball bearing units.

TL Series Spherical Roller Bearings

Dryer rolls are generally used under high-temperature conditions, which can lead to fracturing of the bearing inner ring, and in the worst case, result in work stoppage. NSK's solution is the TL (Tough and Long-life) bearing, which features sufficient strength to resist inner ring fractures, superior dimensional stability under high-temperature conditions, and long life due to superior hardness. All these characteristics mean improved productivity.

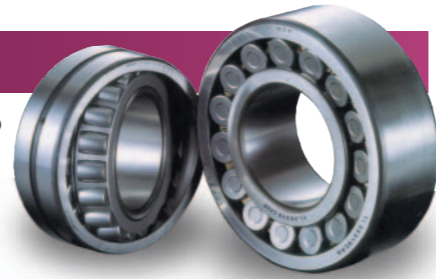

Features

Enhanced inner ring strength

Adoption of a special steel and surface hardening heat treatment, developed by NSK, dramatically enhance inner ring strength against increasing hoop stress caused by rising shaft temperature.

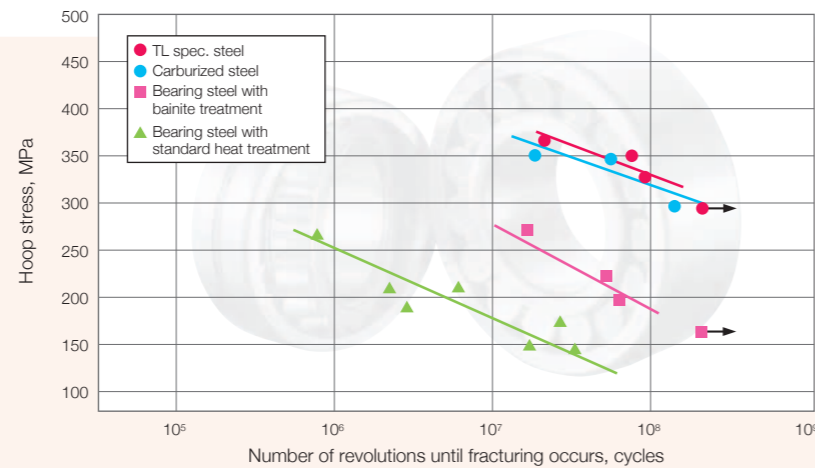

Longer life

Increased hardness of raceway surface provides longer life when foreign debris is present than that of other bearings.

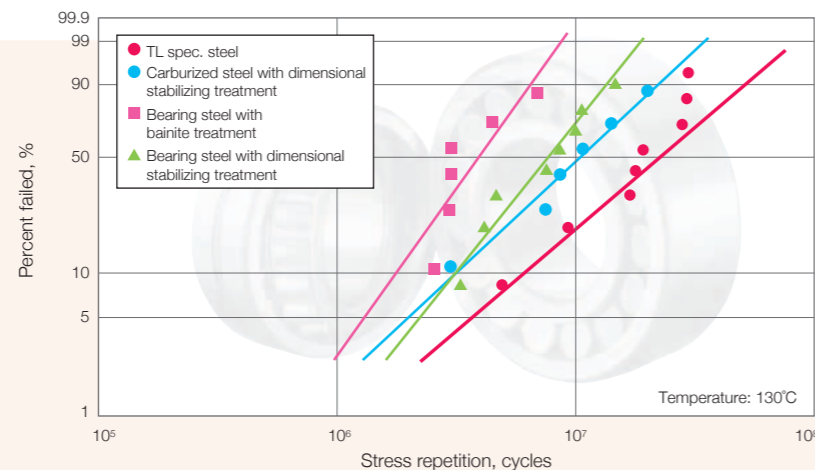

Dimensional stability under high temperatures

High-temperature dimensional stabilization of up to 200°C has been achieved through the application of NSK's proprietary material heat treatment technology.

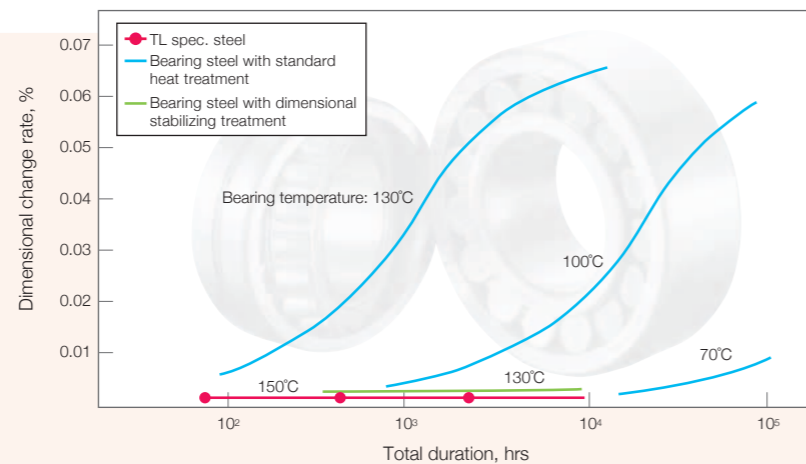

High Performance Standard Bearings for Industrial Machinery

NSKHPS, redefining the standard.

Continually developing products with greater strength and higher accuracy, NSK's new NSKHPS fully incorporate the advantages of NSK's world-class design, materials, and manufacturing technologies, setting a new standard for bearings.

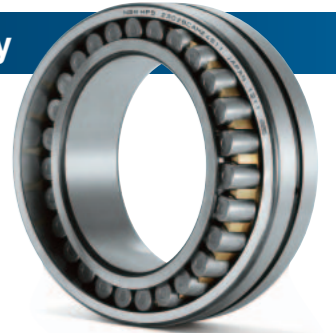

Features

Compared with conventional bearings ...

Bearing life
2
times longer
(maximum)

Limiting speed
20%
higher
(maximum)

Working temperature
up to
200°C



1. Improved reliability

Bearing life has increased by a maximum of 2 times compared with that of conventional bearings by optimization of the bearing's internal design and improved processing technology.

As a result, the NSKHPS bearings contribute to reducing maintenance costs and facilitate the downscaling of related equipment.

2. Improved limiting speed (EA type only).

Limiting speed has been increased by a maximum of 20 % compared with that of conventional bearings by improving cage wear resistance.

3. High temperature dimensional stabilizing treatment comes standard

High-temperature dimensional stabilization of up to 200°C has been achieved through the application of NSK's proprietary material heat treatment technology.

As a result, this series of bearing can be used in a wide range of applications.

CA Series Spherical Roller Bearings

CA series bearings have high load capacity, superior durability, and wear resistance featuring a brass cage for various types of large rolls such as suction rolls, press rolls, calender rolls, and reel drum rolls, etc.

The CA series is available in a wide selection of sizes and other specifications, such as bearings with a lubricant hole and groove provided in the outer ring (E4), high heat-resistant bearings capable of withstanding up to 200°C (S11), and high-precision bearings (class 5).



Deep Groove Ball Bearings for High-speed Expander Rolls

Special bearings offer low frictional torque and minimize surface damage, such as smearing and others, through optimal design of the bearing interior and the adoption of coating treatment on the inner and outer rings.

The bearings are characterized by high performance and quality of the No. 1 brand including low-noise bearings suitable for motors and pumps.

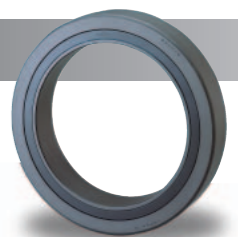

Molded-Oil™ Bearings

Molded-Oil™ bearings are lubricated with NSK's own oil-impregnated material, Molded-Oil™ consists of lubricating oil and polyolefin resin that has an affinity for oil. Oil slowly seeping from this material provides ample lubrication to the bearing for extended periods.



Features

Excellent performance in water- and dust-contaminated environments

The bearings are designed to prevent liquids such as water, which can wash out the lubricating oil, and dust from getting inside the bearings. Sealed types can be used in environments exposed to water and dust.
*Water and dust dramatically accelerate bearing damage. In order to realize stable operation, we recommend using seals to prevent water and dust from getting in the bearing.

Optimal composition and molding methods enable high-speed operation

Optimization of composition and molding method of Molded-Oil™ improves strength and enables high-speed operation.

Low torque

Packing with Molded-Oil™ after providing the bearing surface with special treatment realizes smooth rotation of rolling elements.

Environmentally friendly

The bearings are lubricated by minute quantities of oil exuded by Molded-Oil™, which consequently minimizes oil leakage.

Applications

Material processing equipment (conveyers, agitators), paper mill line equipment (support for wire part rolls), maintenance facilities (carrier rope sheave pulley), and carrier line equipment

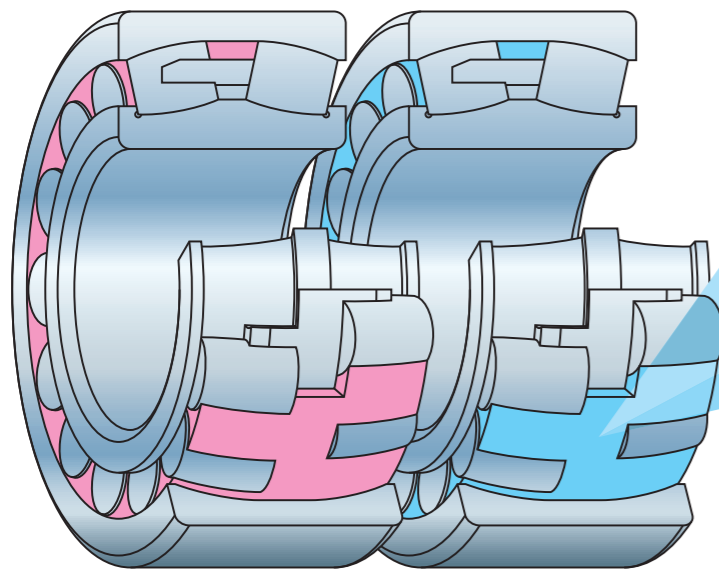

For general use

For high-speed operation

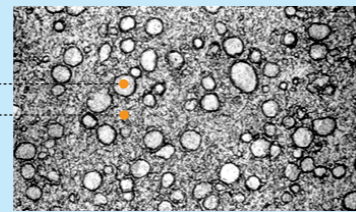

Close-up of Molded-Oil™ | 100 μm

Portion containing mostly lubricating oil
The lubricating oil is mineral oil-based.

Portion containing mostly polyolefin
Polyolefin is an environmentally sound material used for packaging food in supermarkets, replacing dioxin-generating vinyl chloride.

Be aware that this bearing has certain restrictions in regards to ambient operating temperatures and limiting speeds ($d_m n$). Refer to the NSK Molded-Oil™ Bearings catalog (Cat. No. E1216) for details. Furthermore, handling precautions for maintaining the excellent, long-term lubricating capacity of the Molded-Oil™ bearings are listed on page 3 of the same catalog.

EM Series Cylindrical Roller Bearings

The high-load capacity standard cylindrical roller bearing delivers outstanding performance across a wide range of applications. High-load capacity is achieved by using more rollers than conventional bearings based on an innovative NSK concept. We also offer standard cylindrical roller bearings for today's needs that provide longer service life and low-noise and low-vibration performance through an optimally designed one-piece cage with high rigidity and low wear.

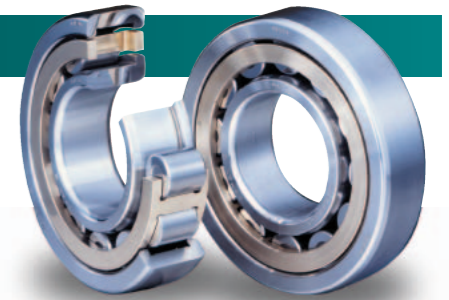

Features Series are available in bearing inner bore dimensions ranging from 25 mm to 200 mm

Compared to the conventional M Series:

Bearing life approximately **2 times**

Low vibration and noise **50% to 60% less**

Cage strength **dramatically enhanced** (generated stress cut in half)

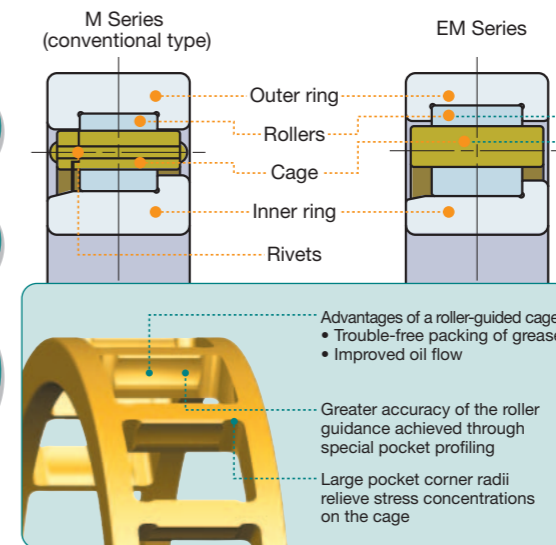

High load rating
Greater number of larger rollers

Low vibration and noise
One-piece cage provides greater accuracy. Roller-guided cage achieves lower running temperature and quieter operation

High-strength and wear-resistant cage
Well-balanced one-piece design

Catalog No. E1237

Triple Ring Bearings

Combination tapered roller bearings have typically been used for the outside of controlled crown rolls (CCR) and spherical roller bearings for the inside. Switching to high-precision, high load capacity triple ring bearings prevents creep, facilitates easier mounting, and extends operating life.



Features

High-load capacity design

Long life
(uses vacuum melted, carburized steel)

High precision
(dimensional and rotational precision)

Optimal inner ring design for lubrication

Lubrication hole and groove provided on inner and outer rings

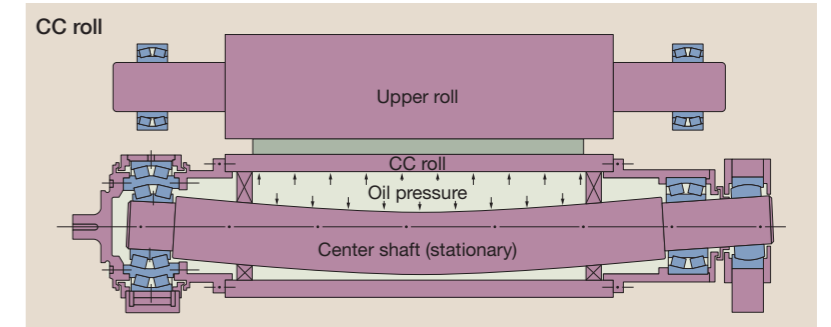

Finite element analysis of housing design for triple ring bearings.

Bearing load distribution is minimized by finite element method (FEM) analysis, thereby contributing to optimal structural design of the housing for paper machine manufacturers.

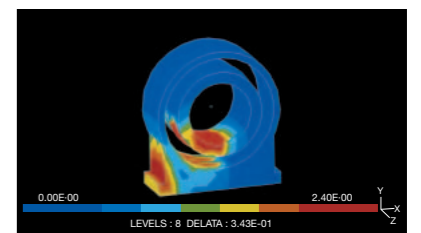

Maximum principle stress distribution

TL Series Spherical Roller Bearings

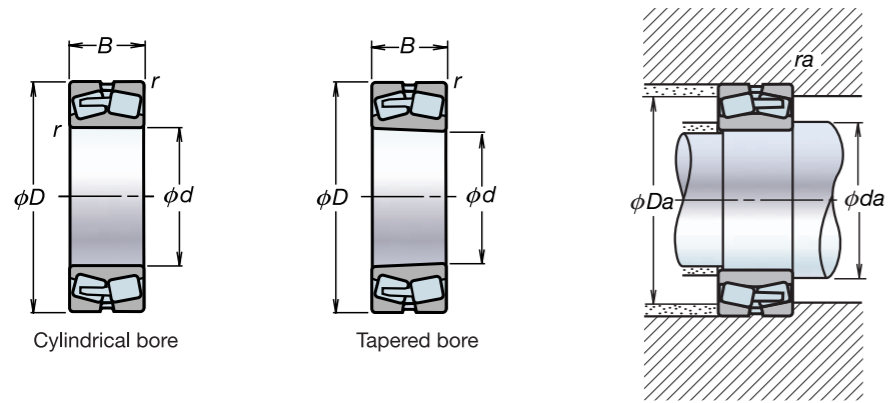

Dynamic equivalent load

$$P = X F_r + Y F_a$$

$F_a / F_r \leq e$		$F_a / F_r > e$	
X	Y	X	Y
1	Y_3	0.67	Y_2

Static equivalent load

$$P_0 = F_r + Y_0 F_a$$

The values for e , Y_2 , Y_3 and Y_0 are given in the table below.

Bearing Nomenclature

Example: **TL 23152 CA g3 M K E4 C3 S11**

Spherical roller bearings (Bearing type);
Width series 3 (Bearing series symbols);
Diameter series 1 (Bearing series symbols);
Bearing bore 260 mm (Bore number)

Machined brass cage (Cage type symbol)

Max. operating temperature: less than 200°C
(Special specification symbol)

Radial clearance C3 (Internal clearance symbol)

Outer ring with oil groove and oil holes (External features symbol)

Tapered bore (External features symbol)

TL spec. Inner ring. (Special spec, material symbol) g5: Inner and outer ring

Boundary dimensions (mm)				Basic load ratings (N)		Limiting speeds (min ⁻¹)		Bearing numbers		Abutment and fillet dimensions (mm)				Constant	Axial load factors			Mass	
<i>d</i>	<i>D</i>	<i>B</i>	<i>r</i> (min.)	<i>C_r</i>	<i>C_{or}</i>	Grease	Oil	Cylindrical bore	Tapered bore (1)	<i>d_a</i> (min.)	<i>d_a</i> (max.)	<i>D_a</i> (max.)	<i>D_a</i> (min.)	<i>r_a</i> (max.)	<i>e</i>	<i>Y₂</i>	<i>Y₃</i>	<i>Y₀</i>	(kg) approx.
65	140	48	2.1	375 000	380 000	3 200	4 000	TL22313EAE4	TL22313EAKE4	77	84	128	119	2	0.33	3.0	2.0	2.0	3.52
70	150	51	2.1	425 000	435 000	3 000	3 800	TL22314EAE4	TL22314EAKE4	82	91	138	129	2	0.33	3.0	2.0	2.0	4.28
90	190	64	3	665 000	705 000	2 400	3 000	TL22318EAE4	TL22318EAKE4	104	115	176	163	2.5	0.33	3.1	2.1	2.0	8.56
100	215	73	3	860 000	930 000	2 000	2 600	TL22320EAE4	TL22320EAKE4	114	130	201	184	2.5	0.33	3.0	2.0	2.0	12.7
110	170	45	2	293 000	465 000	2 000	2 400	TL23022CDE4	TL23022CDKE4	120	124	160	153	2	0.24	4.2	2.8	2.8	3.76
110	200	69.8	2.1	515 000	760 000	1 500	1 900	TL23222CE4	TL23222CKE4	122	130	188	170	2	0.34	3.0	2.0	1.9	9.54
110	240	80	3	825 000	1 120 000	1 700	2 200	TL22322EAE4	TL22322EAKE4	124	145	226	206	2.5	0.30	3.1	2.1	2.0	17.6
120	260	86	3	955 000	1 320 000	1 600	2 000	TL22324EAE4	TL22324EAKE4	134	157	246	222	2.5	0.32	3.1	2.1	2.0	22.2
130	280	93	4	995 000	1 350 000	1 300	1 600	TL22326CAE4	TL22326CAKE4	148	—	262	236	3	0.34	2.9	2.0	1.9	27.8
140	210	53	2	420 000	715 000	1 600	1 900	TL23028CDE4	TL23028CDKE4	150	157	200	190	2	0.22	4.5	3.0	2.9	6.49
140	250	68	3	645 000	930 000	1 400	1 700	TL22228CDE4	TL22228CDKE4	154	167	236	219	2.5	0.25	4.0	2.7	2.6	14.5
140	250	88	3	835 000	1 300 000	1 100	1 500	TL23228CE4	TL23228CKE4	154	163	236	213	2.5	0.35	2.9	1.9	1.9	18.8
150	225	56	2.1	470 000	815 000	1 400	1 800	TL23030CDE4	TL23030CDKE4	162	168	213	203	2	0.22	4.6	3.1	3.0	7.90
150	250	80	2.1	725 000	1 180 000	1 100	1 400	TL23130CAE4	TL23130CAKE4	162	—	238	218	2	0.30	3.4	2.3	2.2	15.8
150	270	73	3	765 000	1 120 000	1 300	1 600	TL22230CDE4	TL22230CDKE4	164	179	256	236	2.5	0.26	3.9	2.6	2.5	18.4
150	320	108	4	1 220 000	1 690 000	1 100	1 400	TL22330CAE4	TL22330CAKE4	168	—	302	270	3	0.35	2.9	1.9	1.9	41.5
160	240	60	2.1	540 000	955 000	1 300	1 700	TL23032CDE4	TL23032CDKE4	172	179	228	216	2	0.22	4.5	3.0	2.9	9.66
160	290	80	3	910 000	1 320 000	1 200	1 500	TL22232CDE4	TL22232CDKE4	174	190	276	255	2.5	0.26	3.8	2.6	2.5	23.1
160	290	104	3	1 100 000	1 770 000	1 000	1 300	TL23232CE4	TL23232CKE4	174	189	276	245	2.5	0.34	2.9	2.0	1.9	30.5
170	230	45	2	350 000	660 000	1 400	1 800	TL23934BCAE4	TL23934BCAKE4	180	—	220	213	2	0.17	5.8	3.9	3.8	5.38
170	260	67	2.1	640 000	1 090 000	1 200	1 600	TL23034CDE4	TL23034CDKE4	182	191	248	233	2	0.23	4.3	2.9	2.8	13.0
170	280	88	2.1	940 000	1 570 000	1 000	1 300	TL23134CAE4	TL23134CAKE4	182	—	268	245	2	0.29	3.5	2.3	2.3	21.0
170	360	120	4	1 580 000	2 110 000	1 000	1 200	TL22334CAE4	TL22334CAKE4	188	—	342	304	3	0.35	2.9	1.9	1.9	57.9
180	280	74	2.1	750 000	1 270 000	1 200	1 400	TL23036CDE4	TL23036CDKE4	192	202	268	249	2	0.24	4.2	2.8	2.8	17.1
180	320	112	4	1 300 000	2 110 000	850	1 100	TL23236CAE4	TL23236CAKE4	198	—	302	274	3	0.35	2.9	1.9	1.9	38.5
190	290	75	2.1	775 000	1 350 000	1 100	1 400	TL23038CDE4	TL23038CDKE4	202	—	278	261	2	0.24	4.2	2.8	2.8	17.6
190	320	104	3	1 190 000	2 020 000	850	1 100	TL23138CAE4	TL23138CAKE4	204	—	306	276	3.5	0.31	3.2	2.2	2.1	34.0
190	340	92	4	1 140 000	1 730 000	1 000	1 200	TL22238CAE4	TL22238CAKE4	208	—	322	296	3	0.26	3.8	2.6	2.5	35.5
190	340	120	4	1 440 000	2 350 000	800	1 100	TL23238CAE4	TL23238CAKE4	208	—	322	288	3	0.35	2.9	1.9	1.9	46.5
190	400	132	5	1 890 000	2 590 000	900	1 100	TL22338CAE4	TL22338CAKE4	212	—	378	338	4	0.34	2.9	2.0	1.9	77.6
200	310	82	2.1	940 000	1 700 000	1 000	1 300	TL23040CDE4	TL23040CDKE4	212	—	298	279	2	0.25	4.0	2.7	2.6	22.6
200	340	112	3	1 360 000	2 330 000	800	1 000	TL23140CAE4	TL23140CAKE4	214	—	326	293	2.5	0.32	3.2	2.1	2.1	41.5
200	360	98	4	1 300 000	2 010 000	950	1 200	TL22240CAE4	TL22240CAKE4	218	—	342	315	3	0.26	3.8	2.6	2.5	42.6
200	360	128	4	1 660 000	2 750 000	750	1 000	TL23240CAE4	TL23240CAKE4	218	—	342	307	3	0.35	2.9	1.9	1.9	57.0
220	340	90	3	1 090 000	1 980 000	950	1 200	TL23044CAE4	TL23044CDKE4	234	—	326	302	2.5	0.24	4.1	2.8	2.7	29.7
220	370	120	4	1 570 000	2 710 000	710	950	TL23144CAE4	TL23144CAKE4	238	—	352	320	3	0.31	3.2	2.2	2.1	52.0
220	400	108	4	1 570 000	2 430 000	850	1 000	TL22244CAE4	TL22244CAKE4	238	—	382	348	3	0.27	3.7	2.5	2.4	59.0
220	400	144	4	2 010 000	3 400 000	670	900	TL23244CAE4	TL23244CAKE4	238	—	382	337	3	0.36	2.8	1.9	1.8	79.5
220	460	145	5	2 350 000	3 400 000	750	950	TL22344CAE4	TL22344CAKE4	242	—	438	391	4	0.33	3.0	2.0	2.0	116
240	320	60	2.1	635 000	1 300 000	950	1 200	TL23948CAE4	TL23948CAKE4	252	—	308	298	2	0.17	6.0	4.0	3.9	13.3
240	360	92	3	1 160 000	2 140 000	850	1 100	TL23048CAE4	TL23048CAKE4	254	—	346	324	2.5	0.24	4.2	2.8	2.7	32.6
240	400	128	4	1 790 000	3 100 000	670	850	TL23148CAE4	TL23148CAKE4	258	—	382	347	3	0.31	3.3	2.2	2.2	64.5
240	500	155	5	2 600 000	3 800 000	670	850	TL22348CAE4	TL22348CAKE4	262	—	478	423	4	0.32	3.2	2.1	2.1	147
260	360	75	2.1	930 000	1 870 000	850	1 000	TL23952CAE4	TL23952CAKE4	272	—	348	333	2	0.19	5.4	3.6	3.5	23.0
260	400	104	4	1 430 000	2 580 000	800	950	TL23052CAE4	TL23052CAKE4	278	—	382	356	3	0.25	4.1	2.7	2.7	46.6
260	440	144	4	2 160 000	3 750 000	600	800	TL23152CAE4	TL23152CAKE4	278	—	422	380	3	0.32	3.2	2.1	2.1	88.2
280	380	75	2.1	925 000	1 950 000	800	950	TL23956CAE4	TL23956CAKE4	292	—	368	351	2	0.18	5.7	3.9	3.8	24.5
280	420	106	4	1 540 000	2 950 000	710	900	TL23056CAE4	TL23056CAKE4	298	—	402	377	3	0.24	4.2	2.8	2.7	50.5
280	460	146	5	2 230 000	4 000 000	560	750	TL23156CAE4	TL23156CAKE4	302	—	438	400	4	0.30	3.3	2.2	2.2	94.3
280	500	176	5	2 880 000	4 900 000	530	670	TL23256CAE4	TL23256CAKE4	302	—	478	425	4	0.35	2.9	1.9	1.9	147
300	420	90	3	1 230 000	2 490 000	710	900	TL23960CAE4	TL23960CAKE4	314	—	406	386	2.5	0.19	5.2	3.5	3.4	38.2
300	460	118	4	1 920 000	3 700 000	670	850	TL23060CAE4	TL23060CAKE4	318	—	442	413	3	0.24	4.2	2.8	2.7	70.5
300	500	160	5	2 670 000	4 800 000	500	670	TL23160CAE4	TL23160CAKE4	322	—	478	433	4	0.31	3.3	2.2	2.2	125
300	540	192	5	3 400 000	5 900 000	480	630	TL23260CAE4	TL23260CAKE4	322	—	518	458	4	0.35	2.9	1.9	1.9	189
320	540	176	5	3 050 000	5 500 000	480	600	TL23164CAE4	TL23164CAKE4	342	—	518	466	4	0.31	3.2	2.1	2.1	162
340	520	133	5	2 280 000	4 400 000	560	710	TL23068CAE4	TL23068CAKE4	362	—	498	465	4	0.24	4.2	2.8	2.8	101
340	580	190	5	3 600 000	6 600 000	430	560	TL23168CAE4	TL23168CAKE4	362	—	558	499	4	0.31	3.2	2.1	2.1	206
360	540	134	5	2 390 000	4 700 000	530	670	TL23072CAE4	TL23072CAKE4	382	—	518	485	4	0.24	4.2	2.8	2.8	106
380	520	106</																	

NSKHPS Spherical Roller Bearings

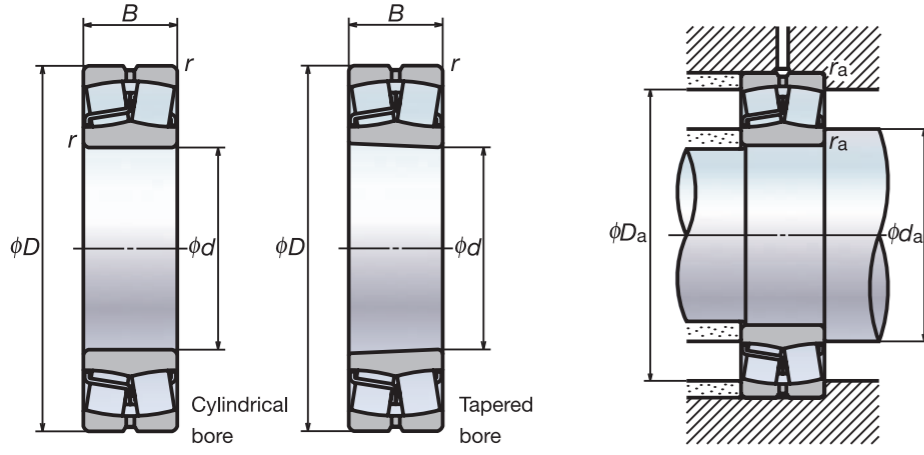

Dynamic equivalent load

$$P = X F_r + Y F_a$$

$F_a / F_r \leq e$		$F_a / F_r > e$	
X	Y	X	Y
1	Y_3	0.67	Y_2

Static equivalent load

$$P_0 = F_r + Y_0 F_a$$

The values for e , Y_2 , Y_3 and Y_0 are given in the table below.

Bearing Nomenclature

Example : **232 36 CA M K E4 C3 S11 *H***

Part of Nomenclature	Meaning
Bearing series symbol	NSKHPS symbol
Bore number	S11: Dimensional stabilizing treatment EA design is omitted (Special specification symbol)
EA, CA: high-load capacity (Internal design symbol)	Radial clearance C3 (Internal clearance symbol)
M: machined brass cage for CA design (Cage symbol)	Outer ring with oil groove and oil holes (External features symbol)
Omitted: pressed steel cage for EA design (Cage symbol)	Tapered bore (External features symbol)

Boundary dimensions (mm)				Basic load ratings (N)		Limiting speeds (min ⁻¹)		Bearing numbers		Abutment and fillet dimensions (mm)					Constant	Axial load factors		
d	D	B	r (min.)	C _r	C _{0r}	Grease	Oil	Cylindrical bore	Tapered bore (°)	d _a (min.)	d _a (max.)	D _a (max.)	D _a (min.)	r _a (max.)	e	Y2	Y3	Y ₀
40	80	23	1.1	113 000	99 500	6 700	8 500	22208EAE4	22208EAK E4	47	49	73	70	1	0.28	3.6	2.4	2.4
	90	23	1.5	118 000	111 000	6 000	7 500	21308EAE4	21308EAK E4	49	54	81	75	1.5	0.25	3.9	2.7	2.6
	90	33	1.5	170 000	153 000	5 300	6 700	22308EAE4	22308EAK E4	49	52	81	77	1.5	0.35	2.8	1.9	1.9
45	85	23	1.1	118 000	111 000	6 000	7 500	22209EAE4	22209EAK E4	52	54	78	75	1	0.25	3.9	2.7	2.6
	100	25	1.5	149 000	144 000	5 000	6 300	21309EAE4	21309EAK E4	54	65	91	89	1.5	0.23	4.3	2.9	2.8
	100	36	1.5	207 000	195 000	4 500	5 600	22309EAE4	22309EAK E4	54	59	91	86	1.5	0.34	2.9	2.0	1.9
50	90	23	1.1	124 000	119 000	5 600	7 100	22210EAE4	22210EAK E4	57	60	83	81	1	0.24	4.3	2.9	2.8
	110	27	2	178 000	175 000	4 500	5 600	21310EAE4	21310EAK E4	60	72	100	98	2	0.23	4.4	3.0	2.9
	110	40	2	246 000	234 000	4 300	5 300	22310EAE4	22310EAK E4	60	64	100	93	2	0.35	2.8	1.9	1.9
55	100	25	1.5	149 000	144 000	5 300	6 700	22211EAE4	22211EAK E4	64	65	91	89	1.5	0.23	4.3	2.9	2.8
	120	29	2	178 000	174 000	4 500	5 600	21311EAE4	21311EAK E4	65	72	110	98	2	0.23	4.4	3.0	2.9
	120	43	2	292 000	292 000	3 800	4 800	22311EAE4	22311EAK E4	65	73	110	103	2	0.34	2.9	2.0	1.9
60	110	28	1.5	178 000	174 000	4 800	6 000	22212EAE4	22212EAK E4	69	72	101	98	1.5	0.23	4.4	3.0	2.9
	130	31	2.1	238 000	244 000	3 800	4 800	21312EAE4	21312EAK E4	72	87	118	117	2	0.22	4.5	3.0	3.0
	130	46	2.1	340 000	340 000	3 600	4 500	22312EAE4	22312EAK E4	72	79	118	111	2	0.34	3.0	2.0	1.9
65	120	31	1.5	221 000	230 000	4 300	5 300	22213EAE4	22213EAK E4	74	80	111	107	1.5	0.24	4.2	2.8	2.7
	140	33	2.1	264 000	275 000	3 600	4 500	21313EAE4	21313EAK E4	77	94	128	126	2	0.22	4.6	3.1	3.0
	140	48	2.1	375 000	380 000	3 200	4 000	22313EAE4	22313EAK E4	77	84	128	119	2	0.33	3.0	2.0	2.0
70	125	31	1.5	225 000	232 000	4 000	5 300	22214EAE4	22214EAK E4	79	84	116	111	1.5	0.23	4.3	2.9	2.8
	150	35	2.1	310 000	325 000	3 200	4 000	21314EAE4	21314EAK E4	82	101	138	135	2	0.22	4.6	3.1	3.0
	150	51	2.1	425 000	435 000	3 000	3 800	22314EAE4	22314EAK E4	82	91	138	129	2	0.33	3.0	2.0	2.0
75	130	31	1.5	238 000	244 000	4 000	5 000	22215EAE4	22215EAK E4	84	87	121	117	1.5	0.22	4.5	3.0	3.0
	160	37	2.1	310 000	325 000	3 200	4 000	21315EAE4	21315EAK E4	87	101	148	134	2	0.22	4.6	3.1	3.0
	160	55	2.1	485 000	505 000	2 800	3 600	22315EAE4	22315EAK E4	87	97	148	137	2	0.33	3.0	2.0	2.0
80	140	33	2	264 000	275 000	3 600	4 500	22216EAE4	22216EAK E4	90	94	130	126	2	0.22	4.6	3.1	3.0
	170	39	2.1	355 000	375 000	3 000	3 800	21316EAE4	21316EAK E4	92	109	158	146	2	0.23	4.4	3.0	2.9
	170	58	2.1	540 000	565 000	2 600	3 400	22316EAE4	22316EAK E4	92	103	158	145	2	0.33	3.0	2.0	2.0
85	150	36	2	310 000	325 000	3 400	4 300	22217EAE4	22217EAK E4	95	101	140	135	2	0.22	4.6	3.1	3.0
	180	41	3	360 000	395 000	3 000	4 000	21317EAE4	21317EAK E4	99	108	166	142	2.5	0.24	4.3	2.9	2.8
	180	60	3	600 000	630 000	2 400	3 200	22317EAE4	22317EAK E4	99	110	166	155	2.5	0.33	3.1	2.1	2.0
90	160	40	2	360 000	395 000	3 200	4 000	22218EAE4	22218EAK E4	100	108	150	142	2	0.24	4.3	2.9	2.8
	190	43	3	415 000	450 000	2 800	3 600	21318EAE4	21318EAK E4	104	115	176	152	2.5	0.24	4.3	2.9	2.8
	190	64	3	665 000	705 000	2 400	3 000	22318EAE4	22318EAK E4	104	115	176	163	2.5	0.33	3.1	2.1	2.0
95	170	43	2.1	415 000	450 000	3 000	3 800	22219EAE4	22219EAK E4	107	115	158	152	2	0.24	4.3	2.9	2.8
	200	45	3	430 000	435 000	1 500	2 000	21319CAME4	21319CAMKE4	109	127	186	172	2.5	0.22	4.6	3.1	3.0
	200	67	3	735 000	780 000	2 200	2 800	22319EAE4	22319EAK E4	109	121	186	172	2.5	0.33	3.1	2.1	2.0
100	180	46	2.1	455 000	490 000	2 800	3 600	22220EAE4	22220EAK E4	112	119	168	160	2	0.24	4.3	2.9	2.8
	180	60.3	2.1	525 000	605 000	1 600	2 200	23220CAME4	23220CAMKE4	112	118	168	155	2	0.32	3.2	2.1	2.1
	215	47	3	495 000	485 000	1 400	1 900	21320CAME4	21320CAMKE4	114	133	201	184	2.5	0.23	4.4	3.0	2.9
	215	73	3	860 000	930 000	2 000	2 600	22320EAE4	22320EAK E4	114	130	201	184	2.5	0.33	3.0	2.0	2.0
110	180	56	2	480 000	630 000	1 600	2 000	23122CAME4	23122CAMKE4	120	127	170	158	2	0.28	3.5	2.4	2.3
	180	69	2	575 000	750 000	1 600	2 000	24122CAME4	24122CAMKE4	120	123	170	154	2	0.36	2.8	1.9	1.8
	200	53	2.1	605 000	645 000	2 600	3 200	22222EAE4	22222EAK E4	122	129	188	178	2	0.25	4.0	2.7	2.6
	200	69.8	2.1	645 000	760 000	1 500	1 900	23222CAME4	23222CAMKE4	122	130	188	170	2	0.34	3.0	2.0	1.9
	240	50	3	565 000	545 000	1 300	1 700	21322CAME4	21322CAMKE4	124	-	226	206	2.5	0.22	4.6	3.1	3.0
	240	80	3	1 030 000	1 120 000	1 900	2 400	22322EAE4	22322EAK E4	124	145	226	206	2.5	0.33	3.1	2.1	2.0
120	180	46	2	395 000	525 000	1 800	2 200	23024CAME4	23024CAMKE4	130	134	170	163	2	0.22	4.5	3.0	2.9
	180	60	2	480 000	680 000	1 500	2 000	24024CAME4	24024CAMKE4	130	131	170	158	2	0.32	3.2	2.1	2.1
	200	62	2	580 000	720 000	1 400	1 800	23124CAME4	23124CAMKE4	130	138	190	175	2	0.29	3.5	2.4	2.3
	200	80	2	695 000	905 000	1 400	1 800	24124CAME4	24124CAMKE4	130	136	190	171	2	0.37	2.7	1.8	1.8
	215	58	2.1	685 000	765 000	2 400	3 000	22224EAE4	22224EAK E4	132	142	203	190	2	0.25	3.9	2.7	2.6
	215	76	2.1	790 000	970 000	1 300	1 700	23224CAME4	23224CAMKE4	132	140	203	182	2	0.34	2.9	2.0	1.9
130	260	86	3	1 190 000	1 320 000	1 700	2 200	22324EAE4	22324EAK E4	134	157	246	222	2.5	0.32	3.1	2.1	2.0
	200	52	2	500 000	655 000	1 700	2 000	23026CAME4	23026CAMKE4	140	147	190	180	2	0.23	4.3	2.9	2.8
	200	69	2	620 000	865 000	1 400	1 800	24026CAME4	24026CAMKE4	140	143	190	175	2	0.31	3.2	2.2	2.1
	210	64	2	630 000	825 000	1 300	1 700	23126CAME4	23126CAMKE4	140	149	200	184	2	0.28	3.6	2.4	2.4
	210	80	2	735 000	1 010 000	1 300	1 700	24126CAME4	24126CAMKE4	140	146	200	180	2	0.37	2.7	1.8	1.8
	230	64	3	820 000	940 000	2 200	2 600	22226EAE4	22226EAK E4	144	152	216	204	2.5	0.26	3.8	2.6	2.5
	230	80	3	875 000	1 080 000	1 200	1 600	23226CAME4	23226CAMKE4	144	150	216	196	2.5	0.34	2.9	2.0	1.9
	280	93	4	1 240 000	1 350 000	1 300	1 600	22326CAME4	22326CAMKE4	148	166	262	236	3	0.34	2.9	2.0	1.9

Note (1) The suffix K indicates that the bearing has a tapered bore (taper 1:12).

Remarks 1. The maximum operating temperature of standard NSKHPS spherical roller bearings is 200°C.
2. The suffix E4 indicates that the bearing has an oil groove and holes

Boundary dimensions (mm)				Basic load ratings (N)		Limiting speeds (min ⁻¹)		Bearing numbers		Abutment and fillet dimensions (mm)					Constant	Axial load factors		
d	D	B	r (min.)	C _r	C _{0r}	Grease	Oil	Cylindrical bore	Tapered bore (°)	d _a (min.)	d _a (max.)	D _a (max.)	D _a (min.)	r _a (max.)	e	Y2	Y3	Y ₀
140	210	53	2	525 000	715 000													

Triple Ring Bearings

Bearing Nomenclature

Example : **2SL 180-2 UPA**

Triple ring bearings
(Spherical roller bearings)

Bearing bore 180 mm

Special accuracy (Tolerance class symbol)

Bearing numbers	Boundary dimensions (mm)					Mass (kg)
	d	D	B_i	B_e	B	
2SL180-2 UPA	180	480	140	160	215.9	175
2SL200-2 UPA	200	520	160	180	241.3	230
2SL220-2 UPA	220	600	180	200	279.4	330
2SL240-2 UPA	240	620	200	200	279.4	410
2SL260-2 UPA	260	680	218	218	317.5	490
2SL280-2 UPA	280	720	218	218	317.5	525
2SL300-2 UPA	300	780	243	250	342.9	735
2SL320-2 UPA	320	820	258	258	368.3	840
2SL340-2 UPA	340	870	280	272	393.7	1 050
2SL380-3 UPA	380	980	240	308	431.8	1 370
2PSL180-1 UPA	180	460	153	118	160	127
2PSL240-1 UPA	240	600	205	160	225	285

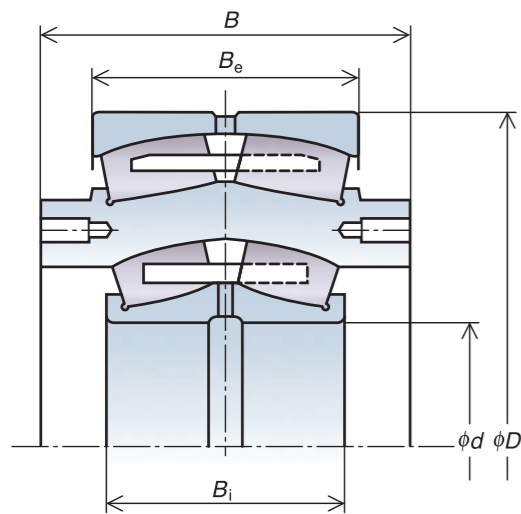

2SL

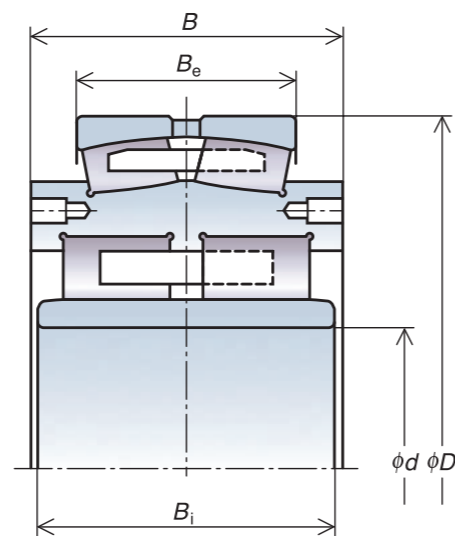

2PSL

Spherical Roller Bearings for Papermaking Machines

TL Bearings
NSKHPS Spherical Roller Bearings

Bore number	239		230		240		231		241		222		232		213		223	
	TL	NSKHPS	TL	NSKHPS	TL	NSKHPS	TL	NSKHPS	TL	NSKHPS	TL	NSKHPS	TL	NSKHPS	TL	NSKHPS	TL	NSKHPS
05																		
06																		
07																		
08																		
09																		
10																		
11																		
12																		
13																		
14																		
15																		
16																		
17																		
18																		
19																		
20																		
22																		
24																		
26																		
28																		
30																		
32																		
34																		
36																		
38																		
40																		
44																		
48																		
52																		
56																		
60																		
64																		
68																		
72																		
76																		
80																		
84																		
88																		
92																		
96																		
/500																		
/530																		
/560																		
/600																		
/630																		

Radial Clearance in Spherical Roller Bearings with Tapered Bores

Bearings with tapered bores are directly mounted onto tapered shafts or onto cylindrical shafts with adapters or withdrawal sleeves (Fig. 1).

Large bearings are often mounted using hydraulic pressure. Fig. 2 shows a bearing mounting utilizing a sleeve and hydraulic nut. Another mounting method is to drill holes in the sleeve which are used to feed oil under pressure to seat the bearing. As the bearing expands radially, the sleeve is inserted axially with adjusting bolts.

The bearing should be mounted with a suitable interference fit by checking residual clearance while measuring their radial-clearance reduction and referring to the amount of axial movement listed in Table 1. Radial clearance must be measured using clearance

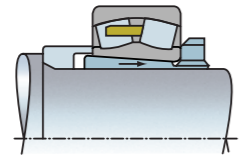

Fig. 1 Mounting with adapter

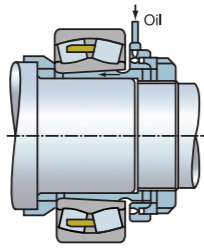

Fig. 2 Mounting with hydraulic nut

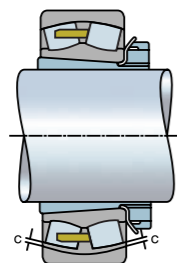

Fig. 3 Clearance measurement of spherical roller bearing

gauges. As shown in Fig 3, radial clearance for both rows of rollers must be measured simultaneously, and those two values should be kept roughly the same.

When a large bearing is mounted on a shaft, the outer ring may be deformed into an oval shape by its own weight. If radial clearance is measured at the lowest part of the deformed bearing, the measured value may be greater than the true value. If an incorrect radial internal clearance is obtained in this manner and the value in Table 1 are used, then the interference fit may become too tight and the true residual clearance may become too small. In this case, as shown in Fig. 4, one half of the total clearance at points a and b (which are on a horizontal line passing through the bearing center) and c (which is the lowest position of the bearing) may be used as the residual clearance.

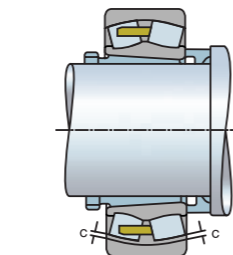
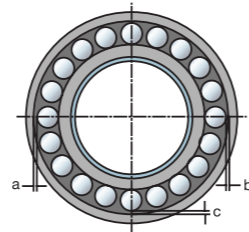

Fig. 4 Measuring clearance in large spherical roller bearing

Table 1 Radial Clearance in Spherical Roller Bearings with Tapered Bores

Unit: mm

Bearing bore diameter <i>d</i>	Clearance in bearings with tapered bores						Reduction in radial clearance		Axial movement				Minimum permissible residual clearance			
	over	incl	CN min	CN max	C3 min	C3 max	C4 min	C4 max	min	max	Taper 1:12 min	Taper 1:12 max	Taper 1:30 min	Taper 1:30 max	CN	C3
30	40	0.035	0.050	0.050	0.065	0.065	0.085	0.025	0.030	0.40	0.45	—	—	0.010	0.025	0.035
40	50	0.045	0.060	0.060	0.080	0.080	0.100	0.030	0.035	0.45	0.55	—	—	0.015	0.030	0.045
50	65	0.055	0.075	0.075	0.095	0.095	0.120	0.030	0.035	0.45	0.55	—	—	0.025	0.035	0.060
65	80	0.070	0.095	0.095	0.120	0.120	0.150	0.040	0.045	0.60	0.70	—	—	0.030	0.040	0.075
80	100	0.080	0.110	0.110	0.140	0.140	0.180	0.045	0.055	0.70	0.85	1.75	2.15	0.035	0.050	0.085
100	120	0.100	0.135	0.135	0.170	0.170	0.220	0.050	0.060	0.75	0.90	1.9	2.25	0.045	0.065	0.110
120	140	0.120	0.160	0.160	0.200	0.200	0.260	0.060	0.070	0.90	1.1	2.25	2.75	0.055	0.080	0.130
140	160	0.130	0.180	0.180	0.230	0.230	0.300	0.065	0.080	1.0	1.3	2.5	3.25	0.060	0.100	0.150
160	180	0.140	0.200	0.200	0.260	0.260	0.340	0.070	0.090	1.1	1.4	2.75	3.5	0.070	0.110	0.170
180	200	0.160	0.220	0.220	0.290	0.290	0.370	0.080	0.100	1.3	1.6	3.25	4.0	0.070	0.110	0.190
200	225	0.180	0.250	0.250	0.320	0.320	0.410	0.090	0.110	1.4	1.7	3.5	4.25	0.080	0.130	0.210
225	250	0.200	0.270	0.270	0.350	0.350	0.450	0.100	0.120	1.6	1.9	4.0	4.75	0.090	0.140	0.230
250	280	0.220	0.300	0.300	0.390	0.390	0.490	0.110	0.140	1.7	2.2	4.25	5.5	0.100	0.150	0.250
280	315	0.240	0.330	0.330	0.430	0.430	0.540	0.120	0.150	1.9	2.4	4.75	6.0	0.110	0.160	0.280
315	355	0.270	0.360	0.360	0.470	0.470	0.590	0.140	0.170	2.2	2.7	5.5	6.75	0.120	0.180	0.300
355	400	0.300	0.400	0.400	0.520	0.520	0.650	0.150	0.190	2.4	3.0	6.0	7.5	0.130	0.200	0.330
400	450	0.330	0.440	0.440	0.570	0.570	0.720	0.170	0.210	2.7	3.3	6.75	8.25	0.140	0.220	0.360
450	500	0.370	0.490	0.490	0.630	0.630	0.790	0.190	0.240	3.0	3.7	7.5	9.25	0.160	0.240	0.390
500	560	0.410	0.540	0.540	0.680	0.680	0.870	0.210	0.270	3.4	4.3	8.5	11.0	0.170	0.270	0.410
560	630	0.460	0.600	0.600	0.760	0.760	0.980	0.230	0.300	3.7	4.8	9.25	12.0	0.200	0.310	0.460
630	710	0.510	0.670	0.670	0.850	0.850	1.090	0.260	0.330	4.2	5.3	10.5	13.0	0.220	0.330	0.520
710	800	0.570	0.750	0.750	0.960	0.960	1.220	0.280	0.370	4.5	5.9	11.5	15.0	0.240	0.390	0.590
800	900	0.640	0.840	0.840	1.070	1.070	1.370	0.310	0.410	5.0	6.6	12.5	16.5	0.280	0.430	0.660
900	1 000	0.710	0.930	0.930	1.190	1.190	1.520	0.340	0.460	5.5	7.4	14.0	18.5	0.310	0.470	0.730
1 000	1 120	0.770	1.030	1.030	1.300	1.300	1.670	0.370	0.500	5.9	8.0	15.0	20.0	0.360	0.530	0.800

Bearing Maintenance and Inspection

NSK HPE

Maintenance

Bearings and operating conditions must be periodically inspected and maintained to maximize bearing life to prevent mechanical failure, ensure reliable operation, raise productivity, and enhance cost performance.

Maintenance should be performed regularly according to work standards that may vary according to machine operating conditions. Operating conditions should be monitored, lubricant replenished or changed, and the machine periodically disassembled and overhauled.

1. Inspection under operating conditions

Review lubricant properties, check operating temperatures, and inspect for any vibrations and bearing noise to determine bearing replacement periods and replenishment intervals of the lubricant.

2. Inspection of the bearing

Be sure to thoroughly examine the bearings during periodic machine inspections and part replacement. Check the raceway for any damage and confirm if the bearing can be reused or should be replaced.

Inspection points

Items to be checked while the machine is running should include bearing noise, vibrations, temperature, and lubricant condition.

1. Bearing noise

Sound detection instruments can be used during operation to ascertain the volume and characteristics of bearing rotation noise through sound patterns that are readily distinguishable, which can reveal the presence of bearing damage such as slight flaking. Three typical noise conditions are described in Table 1.

2. Bearing vibration

Bearing irregularities can be analyzed by performing a quantitative analysis of vibration amplitude and frequency using a frequency spectrum analyzer. Measured data varies depending on the operating conditions of the bearing and the location of the vibration pick-up. Therefore, this method requires the determination of evaluation standards for each measured machine.

Table 1 Bearing irregularity causes and measures

Irregularities	Possible causes	Measures	
Noise	Loud metallic sound	Abnormal load	Improve the fit, internal clearance, preload, or position of housing shoulder.
		Incorrect mounting	Improve machining accuracy, alignment accuracy or mounting accuracy of shaft and housing, or use the correct mounting method.
		Insufficient or improper lubricant	Replenish the lubricant or select another lubricant.
	Loud regular sound	Contact of rotating parts	Modify the labyrinth seal.
		Flaws, corrosion, or scratches on raceways caused by foreign particles	Replace or clean the bearing, improve sealing conditions, or use clean lubricant.
			Brinelling
Irregular sound	Flaking on raceway	Replace the bearing.	
	Excessive clearance	Improve the fit, clearance, or preload.	
	Contamination by foreign particles	Replace or clean the bearing, improve the seals, and use clean lubricant.	
Abnormal temperature rise	Excessively small clearance	Replace the bearing.	
		Excessive amount of lubricant	Reduce amount of lubricant and select stiffer grease.
		Insufficient or improper lubricant	Replenish lubricant or select a proper one.
	Abnormal load	Improve the fit, internal clearance, preload, or position of housing shoulder.	
		Incorrect mounting	Improve machining accuracy, alignment accuracy or mounting accuracy of shaft and housing, or use the correct mounting method.
		Creep on fitted surface, or excessive seal friction	Correct the seals, replace the bearing, and correct the fitting or mounting.
Vibration (Axial runout)	Brinelling	Replace the bearing, and use care when handling bearings.	
	Flaking	Replace the bearing.	
	Incorrect mounting	Correct the squareness between the shaft and housing shoulder or side of spacer.	
	Penetration of foreign particles	Replace or clean the bearing components and improve sealing.	
Leakage or discoloration of lubricant	Too much lubricant, or contamination by foreign particles or wear debris	Reduce the amount of lubricant. Select a stiffer grease. Replace the bearing or lubricant. Clean the housing and adjacent parts.	

Examples of Bearing damage and countermeasures for papermaking machines



Creep

Bearing type	Application	Cause of damage	Measures
Tapered Roller Bearing	Press CC roll	<ul style="list-style-type: none"> • Insufficient interference fit 	<ul style="list-style-type: none"> • Tighten interference fit
Spherical Roller Bearing	Dryer canvas roll	<ul style="list-style-type: none"> • Dimensional variation at high temperatures 	<ul style="list-style-type: none"> • Use TL steel • Use NSKHPS bearing • Apply high-temperature dimensional stabilizing treatment (S11)

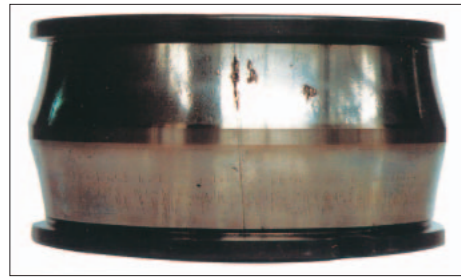

Inner ring fracture

Bearing type	Application	Cause of damage	Measures
Spherical Roller Bearing	Dryer cylinder roll	<ul style="list-style-type: none"> • Excessive force applied during mounting • Defective bore face contact • High hoop stress 	<ul style="list-style-type: none"> • Control residual clearance • Adjust with taper gauge • Use TL steel



Rust and corrosion

Bearing type	Application	Cause of damage	Measures
Spherical Roller Bearing	Wire suction roll	<ul style="list-style-type: none"> • Insufficient oil film formation due to water entry 	<ul style="list-style-type: none"> • Reinforce lubricating oil control • Improve bearing housing • Anti-rust treatment for idle periods
	Press suction roll	<ul style="list-style-type: none"> • Rust formed while stationary or being stored 	



Flaking

Bearing type	Application	Cause of damage	Measures
Spherical Roller Bearing	Wire suction roll	<ul style="list-style-type: none"> • Insufficient oil film formation due to water entry 	<ul style="list-style-type: none"> • Reinforce lubricating oil control • Improve bearing housing
	Dryer cylinder roll	<ul style="list-style-type: none"> • Insufficient oil film formation at high temperatures 	<ul style="list-style-type: none"> • Use TL steel • Increase oil viscosity • Increase volume and reinforce control of lubricating oil temperature • Use thermal insulation sleeve
	Dryer canvas roll	<ul style="list-style-type: none"> • Excessive axial loading due to expansion of outer ring on the free-end bearing 	<ul style="list-style-type: none"> • Use TL steel • Use NSKHPS bearing • Apply high temperature dimensional stabilizing treatment (S11)

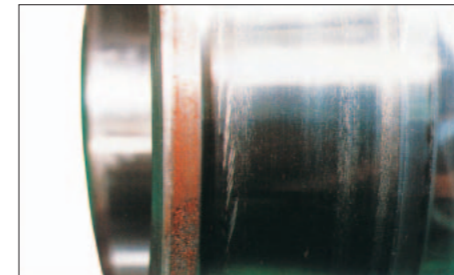

Smearing

Bearing type	Application	Cause of damage	Measures
Spherical Roller Bearing	Calender CC roll (triple ring)	<ul style="list-style-type: none"> • Insufficient oil film formation 	<ul style="list-style-type: none"> • Increase oil viscosity • Increase oil volume and reinforce control of lubricating oil temperature • Add additives to lubricating oil



Electrical corrosion

Bearing type	Application	Cause of damage	Measures
Deep Groove Ball Bearing Cylindrical Roller Bearing	Motor	<ul style="list-style-type: none"> • Sparks produced by flow of current where rolling elements contact the raceway 	<ul style="list-style-type: none"> • Design electric circuit which prevents current flow through the bearings • Insulate the bearing

Worldwide Sales Offices

P: Phone ☆: Head Office

NSK LTD. HEADQUARTERS, TOKYO JAPAN

INDUSTRIAL MACHINERY BUSINESS DIVISION-HEADQUARTERS P: +81-3-3779-7227
AUTOMOTIVE BUSINESS DIVISION-HEADQUARTERS P: +81-3-3779-7189

Africa

South Africa:

NSK SOUTH AFRICA (PTY) LTD.

JOHANNESBURG P: +27-11-458-3600

Aisia and Oceania

Australia:

NSK AUSTRALIA PTY. LTD.

MELBOURNE ☆ P: +61-3-9765-4400
SYDNEY P: +61-2-8843-8100
BRISBANE P: +61-7-3347-2600
PERTH P: +61-8-9256-5000

New Zealand:

NSK NEW ZEALAND LTD.

AUCKLAND P: +64-9-276-4992

China:

NSK HONG KONG LTD.

HONG KONG ☆ P: +852-2739-9933
SHENZHEN P: +86-755-25904886

NSK (SHANGHAI) TRADING CO., LTD.

JIANGSU P: +86-512-5796-3000

NSK (CHINA) INVESTMENT CO., LTD.

JIANGSU ☆ P: +86-512-5796-3000
BEIJING P: +86-10-6590-8161
TIAN JIN P: +86-22-8319-5030
CHANGCHUN P: +86-431-8898-8682
SHENYANG P: +86-24-2334-2868
DALIAN P: +86-411-8800-8168
NANJING P: +86-25-8472-6671
FUZHOU P: +86-591-8380-1030
WUHAN P: +86-27-8556-9630
QINGDAO P: +86-532-5568-3877
GUANGZHOU P: +86-20-3817-7800
CHANGSHA P: +86-731-8571-3100
LUOYANG P: +86-379-6069-6188
XI'AN P: +86-29-8765-1896
CHONGQING P: +86-23-6806-5310
CHENGDU P: +86-28-8528-3680

NSK CHINA SALES CO., LTD.

JIANGSU P: +86-512-5796-3000

India:

NSK INDIA SALES CO.PVT.LTD.

CHENNAI ☆ P: +91-44-2847-9600
GURGAON P: +91-124-4104-530
MUMBAI P: +91-22-2838-7787

Indonesia:

PT. NSK INDONESIA

JAKARTA P: +62-21-252-3458

Korea:

NSK KOREA CO., LTD.

SEOUL P: +82-2-3287-0300

Malaysia:

NSK BEARINGS (MALAYSIA) SDN.BHD.

SHAH ALAM ☆ P: +60-3-7803-8859
PRAI P: +60-4-3902275
JOHOR BAHRU P: +60-7-3546290
IPOH P: +60-5-2555000

Philippines:

NSK REPRESENTATIVE OFFICE

MANILA P: +63-2-893-9543

Singapore:

NSK INTERNATIONAL (SINGAPORE) PTE LTD.

SINGAPORE P: +65-6496-8000

NSK SINGAPORE (PRIVATE) LTD.

SINGAPORE P: +65-6496-8000

Taiwan:

TAIWAN NSK PRECISION CO., LTD.

TAIPEI ☆ P: +886-2-2509-3305
TAICHUNG P: +886-4-2311-7978
TAINAN P: +886-6-505-5861

TAIWAN NSK TECHNOLOGY CO., LTD.

TAIPEI ☆ P: +886-2-2509-3305
TAICHUNG P: +886-4-2358-2945
TAINAN P: +886-6-505-5861

Thailand:

NSK BEARINGS (THAILAND) CO., LTD.

BANGKOK P: +66-2320-2555

Vietnam:

NSK VIETNAM CO., LTD.

HANOI P: +84-4-3955-0159

NSK REPRESENTATIVE OFFICE

HO CHI MINH CITY P: +84-8-3822-7907

Europe

United Kingdom:

NSK EUROPE LTD. (EUROPEAN HEADQUARTERS)

MAIDENHEAD P: +44-1628-509-800

NSK UK LTD.

NEWARK P: +44-1636-605-123

France:

NSK FRANCE S.A.S.

PARIS P: +33-1-30-57-39-39

Germany:

NSK DEUTSCHLAND GMBH

DUSSELDORF ☆ P: +49-2102-4810
STUTTGART P: +49-711-79082-0
WOLFSBURG P: +49-5361-27647-10

Italy:

NSK ITALIA S.P.A.

MILANO P: +39-299-5191

Netherlands:

NSK EUROPEAN DISTRIBUTION CENTRE B.V.

TILBURG P: +31-13-4647647

Poland:

NSK REPRESENTATIVE OFFICE

WARSAW P: +48-22-645-1525

Russia:

NSK POLSKA SP. Z O.O.

SAINT-PETERSBURG P: +7-812-332-5071

Spain:

NSK SPAIN S.A.

BARCELONA P: +34-93-433-5775

Turkey:

NSK RULMANLARI ORTA DOGU TIC. LTD. STL

ISTANBUL P: +90-216-477-7111

UAE:

NSK BEARINGS GULF TRADING CO.

DUBAI P: +971-4-804-8200

North and South America

United States of America:

NSK AMERICAS, INC. (AMERICAN HEADQUARTERS)

ANN ARBOR P: +1-734-913-7500

NSK CORPORATION

ANN ARBOR P: +1-734-913-7500

NSK PRECISION AMERICA, INC.

FRANKLIN ☆ P: +1-317-738-5000
SAN JOSE P: +1-408-944-9400

NSK LATIN AMERICA, INC.

MIAMI P: +1-305-477-0605

Canada:

NSK CANADA INC.

TORONTO ☆ P: +1-905-890-0740
MONTREAL P: +1-514-633-1220
VANCOUVER P: +1-877-994-6675

Argentina:

NSK ARGENTINA SRL

BUENOS AIRES P: +54-11-4704-5100

Brazil:

NSK BRASIL LTDA.

SAO PAULO ☆ P: +55-11-3269-4786
BELO HORIZONTE P: +55-31-3274-2591
JOINVILLE P: +55-47-3422-5445
PORTO ALEGRE P: +55-51-3222-1324
RECIFE P: +55-81-3326-3781

Peru:

NSK PERU S.A.C.

LIMA P: +51-1-652-3372

Mexico:

NSK RODAMIENTOS MEXICANA, S.A. DE C.V.

MEXICO CITY ☆ P: +52-55-3682-2900
MONTERREY P: +52-81-8000-7300

<As of June 2013>

For the latest information, please refer to the NSK website.

www.nsk.com

NSK Ltd. has a basic policy not to export any products or technology designated as controlled items by export-related laws. When exporting the products in this brochure, the laws of the exporting country must be observed. Specifications are subject to change without notice and without any obligation on the part of the manufacturer. Every care has been taken to ensure the accuracy of the data contained in this brochure, but no liability can be accepted for any loss or damage suffered through errors or omissions. We will gratefully acknowledge any additions or corrections.

For more information about NSK products, please contact: _____

