

Made for Motion



Drive Technology

Couplings

Torque limiters

Clamping elements

Torque measuring systems



www.ktr.com

FUTURE WITH A SYSTEM.

KTR have consistently continued to extend their expertise in building systems over the past few decades. Today we are a leading manufacturer providing solutions with highest quality standards in the fields of drive technology, brake and cooling systems as well as hydraulic components to our global business partners.

So what would be more obvious than adapting our company name to this development? KTR Kupplungstechnik GmbH has become KTR Systems GmbH.

The change of name takes account of the growing diversity of our performance range demonstrating the global markets and our customers that we are prepared to take over just more responsibility in machines and plants.

THAT'S WHAT IT IS ALL ABOUT.

KTR has set things in motion for more than 50 years. And since you can go far if you move a lot, KTR has meanwhile become a worldwide leader in the range of drive and fluid technology for industrial applications. Every year several millions of couplings covering a weight from 5 grams to 2 tons or more come off the assembly in KTR performing reliably even under harshest conditions – on all continents of the earth.

„Innovation & tradition are the key components of our product portfolio and KTR's corporate culture“

Nicola Warning, CEO of KTR

EXPERIENCE MAKES THE DIFFERENCE.

Years of experience with applications at customer sites and additional test series in the KTR test field in Rheine enabled us to determine potentials on the one hand allowing for an increase of torques and on the other hand an increase of pressure resistance.

Pin & bush coupling: starting on page 75
REVOLEX®

Steel lamina coupling: starting on page 184
RADEX®-N

Flange couplings: starting on page 206
BoWex® FLE-PAC,
BoWex® ELASTIC®,
MONOLASTIC®



TORQUE INCREASE

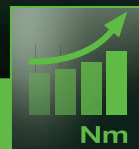

Magnetic coupling: starting on page 229
MINEX®-S

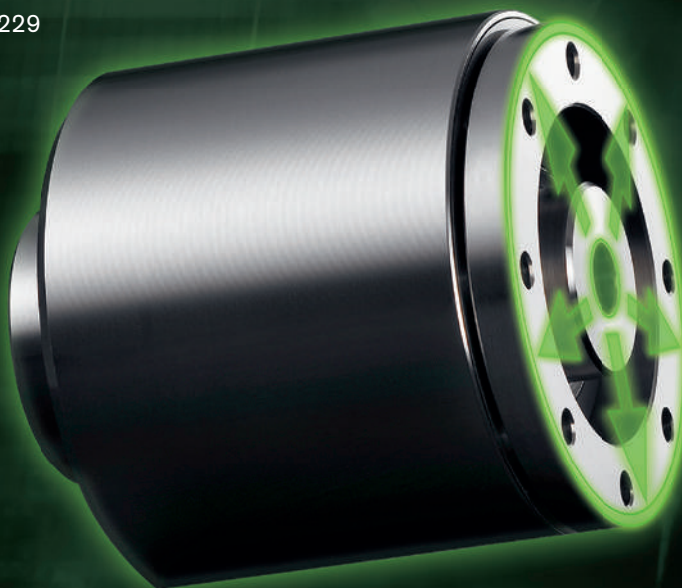

HIGHER PRESSURE RESISTANCE



Those who value KTR as a manufacturer will love us as a partner.

KTR provide the machinery and plant engineering with an extensive portfolio of high-quality drive and hydraulic components and cooling systems. We are pleased to be at your service during the designing stage to develop tailor-made solutions for you. Perfectly organized logistics, global presence via 24 subsidiary companies and more than 90 distributors along with an international network consisting of 8 production sites are the prerequisite for quick delivery. When it comes to service we ensure short distances along with competent and personal support.





**Wherever motion is essential,
we have the right answer.**



Drive technology

Mechanical components are and will remain essential in drive technology. The industry's demands on components grow continuously: energy efficiency, power density, ease of servicing and electrification. Our portfolio includes couplings and torque limiters, clamping sets and precision joints as well as torque measuring shafts.

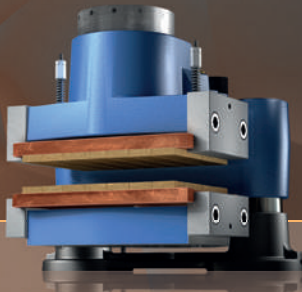

Brake systems

Our hydraulic and electromechanical brake systems are globally used in various industries. Customer preference and parameters of the application decide on the selection of the right brake.



Hydraulic components

For almost 50 years we have provided the industry with a continuously growing range of hydraulic components from our in-house development and production: accurate selection, high-quality processing, quick availability.



Cooling systems

As a customised product or standard solution, multimediuim or oil/air cooler, for mobile machines or stationary hydraulics, optionally available as a marine or ATEX version, powerful and efficient.

UNSERE BRANCHEN



Wind power



Construction and agricultural machinery



Pumps and compressors



Indoor materials handling



Machine tools



Hydraulics

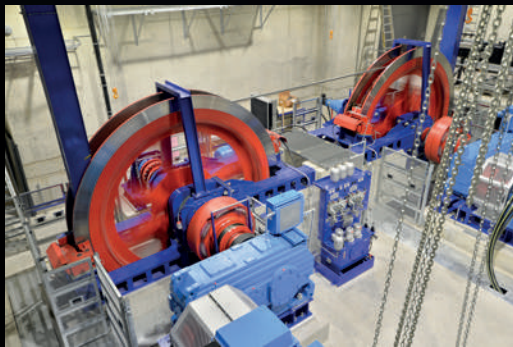

General drive technology

















Marine / shipbuilding



Stationary energy production

SUMMARY OF PRODUCTS/INDUSTRIES

WIND POWER	Gearless wind turbines	Wind turbines	Local power grids	CONSTRUCTION AND AGRICULTURAL MACHINERY	Excavators	Road rollers	Crushers	Harvesters	Tank spreaders	PUMPS AND COMPRESSORS	Compressors	Pumps	Cooling towers	INDOOR MATERIALS HANDLING	Conveying and storage	Food processing machinery	Packaging machinery
																	

COUPLINGS

Flexible jaw and pin & bush couplings

ROTEX®		■			■	■	■	■	■		■	■	■		■	■	■	■
POLY-NORM®											■	■	■					
POLY											■							
REVOLEX® KX-D							■				■							

Gear couplings

BoWex®						■					■	■				■	■	■
BoWex® HEW Compact											■	■						
GEARex®											■				■	■	■	■

Backlash-free servo couplings

ROTEX® GS	■	■	■			■									■	■	■	■
ROTEX® GS P / HP																		
KTR-STOP® NC																		
TOOLFLEX®		■													■	■	■	■
RADEX®-NC															■	■	■	■
COUNTEX®		■													■	■	■	■

Steel lamina couplings

RADEX®-N		■									■	■	■		■	■	■	■
RIGIFLEX®-N											■	■						
RIGIFLEX®-HP											■	■						

Flange couplings for I. C.-engines

Pump mounting flange						■	■	■	■						■			
BoWex® FLE-PA / FLE-PAC						■	■	■	■						■			
MONOLASTIC®						■	■	■	■						■			
BoWex-ELASTIC®						■	■	■	■		■	■						

Magnetic couplings

MINEX®-S											■	■			■	■	■	■
----------	--	--	--	--	--	--	--	--	--	--	---	---	--	--	---	---	---	---

TORQUE LIMITERS

RUFLEX®						■	■	■							■	■	■	■
KTR SI/KTR SI Compact											■	■			■	■	■	■
SYNTEX®/SYNTEX®-NC															■	■	■	■

CLAMPING SETS

CLAMPEX®		■				■	■	■	■		■	■	■		■	■	■	■
----------	--	---	--	--	--	---	---	---	---	--	---	---	---	--	---	---	---	---

TORQUE MEASURING SHAFTS

DATAFLEX®		■	■			■					■	■						■
-----------	--	---	---	--	--	---	--	--	--	--	---	---	--	--	--	--	--	---

Automation	MACHINE TOOLS	Positioning axes	Main spindle drives	Robotic drives	HYDRAULICS	Power pack production	Plastics processing industry	GENERAL DRIVE TECHNOLOGY	Industrial gears	Planetary gears	Extruders	Metering machines	Steel mills	Linear technology	SHIPBUILDING / MARINE	Cargo	Cruises	Yachts	Workboats	GENSETS	Emergency power generators	Product pages from page
					■	■		■	■	■	■	■			■	■	■	■				38
					■			■	■	■	■	■										63
								■	■													71
								■	■			■			■	■						75
					■	■		■			■											88
								■		■												102
								■	■	■		■			■	■	■	■				108
	■		■		■	■		■	■		■		■									122
		■																				136
	■				■																	150
	■		■						■		■		■									152
	■		■						■		■		■									170
	■		■										■									176
								■	■			■	■		■	■	■	■				182
																						192
																						198
																						203
																						204
																						216
																				■		220
																						232
								■	■		■	■	■									246
								■	■	■	■	■	■		■	■	■	■			■	252
	■		■					■	■	■	■	■	■			■	■	■				262
																						280
																						326

SUMMARY OF PRODUCTS / SPECIFICATIONS

Max. torque [Nm]	Max. circumfer. speed [m/s]	Max. bore diameter [mm]	Torsionally rigid	Flexible	Highly torsionally flexible	Backlash-free	Maintenance-free	Fail-safe	Shear type	Compact dimensions	Double-cardanic	Single-cardanic	High
------------------	-----------------------------	-------------------------	-------------------	----------	-----------------------------	---------------	------------------	-----------	------------	--------------------	-----------------	-----------------	------

COUPLINGS

Flexible jaw and pin & bush couplings

ROTEX®	35,000	60	200		■			■	■		■	■	■	■
POLY-NORM®	67,000	35	280		■			■	■		■		■	
POLY	6,100	35	145		■			■					■	
REVOLEX® KX-D	1,350,000	60	650		■		■	■	■		■		■	■

Gear couplings

BoWex®	2,500	30	125	■				■		■	■	■	■	
BoWex® HEW Compact	8,400		125			■		■		■	■	■	■	
GEARex®	2,750,000	-	520	■				■		■	■	■	■	■

Backlash-free servo couplings

ROTEX® GS	5,850	80	110		■		■	■	■		■	■	■	■
KTR-STOP® NC														
TOOLFLEX®	600	40	65	■			■	■		■	■	■		
RADEX®-NC	300	35	55	■			■	■		■	■	■		
COUNTEX®	1	40	14	■			■	■		■	■			

Steel lamina couplings

RADEX®-N	280,000	65	330	■			■	■		■	■	■		
RIGIFLEX®-N	280,000	100	400	■			■	■		■	■			
RIGIFLEX®-HP	330,000	200	380	■			■	■		■	■			

Flange couplings for I. C.-engines

BoWex® FLE-PA / FLE-PAC	6,600	50	125	■				■		■	■		■	
MONOLASTIC®	1,850	50	60		■			■		■	■		■	
BoWex-ELASTIC®	70,000		275			■		■		■	■		■	

Magnetic couplings

MINEX®-S	1,000		90		■			■						
----------	-------	--	----	--	---	--	--	---	--	--	--	--	--	--

TORQUE LIMITERS

RUFLEX®	12,000		140							■				■
KTR-SI	8,200		100											
KTR-SI FRE	60,000		200											
KTR-SI FRA	2,600		80											
SYNTEX®	400		50				■			■				
SYNTEX®-NC	550		60				■			■				■
KTR-SI Compact	3,100		80				■							







CLAMPING SETS

CLAMPEX®	7,394,000		1,000				■	■			■			■
----------	-----------	--	-------	--	--	--	---	---	--	--	---	--	--	---

TORQUE MEASURING SHAFTS

DATAFLEX®	50,000	-	-	■			■	■						
-----------	--------	---	---	---	--	--	---	---	--	--	--	--	--	--

For legend of certificate please refer to flapper on the cover

High power density	Axial plug-in	All-steel	Contactless	Friction coupling	Ratchet coupling	Self-centering	Not self-centering	MARINE						
														
													Coupling selection acc. to DIN 740 part II (page 10 et seqq.)	
													Coupling selection based on operating factors (page 14 et seqq.)	
													Coupling selection acc. to DIN 740 part II with spec. factors (page 18 et seqq.)	
													Product pages from page	

■							■	■	■	■	■	■	■	■	38
■							■	■					■		63
■							■	■					■		71
■							■	■	■	■	■			■	75
■							■	■	■				■		88
■							■	■					■		102
	■						■		■	■	■			■	108
■							■							■	122
															150
■	■													■	152
							■							■	170
■							■							■	176
	■						■	■	■	■	■			■	182
	■						■	■	■	■	■			■	192
	■						■	■	■	■	■			■	198
■								■	■				■		204
■								■					■		216
■							■	■	■	■	■			■	220
		■					■								232
			■												246
	■			■											252
	■				■										253
	■					■									264
						■									262
						■									270
	■					■									275
					■	■		■							282
		■													328

INDEX OF SUBJECTS

A			
Mounting flanges		192 et seqq.	
Drop-out center design coupling	48 et seqq., 72, 75, 112, 142 et seqq., 203 et seqq.		
External clamping sets		298 et seqq.	
B			
Bellow-type couplings		152 et seqq.	
Crowned gear couplings	84 et seqq., 200 et seqq.		
Basic programme		36, 90	
Coatings		43	
Curved-tooth gear couplings®	84 et seqq., 200 et seqq.		
Pin & bush couplings (torsionally flexible)		77 et seqq.	
Shear pin couplings		62	
D			
Permanent-magnetic couplings		228 et seqq.	
Distance couplings	51 et seqq., 72, 75, 112, 146 et seqq., 186 et seqq.		
Double-cardanic shaft couplings	51 et seqq., 91 et seqq., 108 et seqq., 144 et seqq., 164, 166 et seqq., 180 et seqq.		
Torsionally flexible couplings		27 et seqq.	
Shaft encoder couplings		130, 154, 176	
Torque limiters		242 et seqq.	
Torque measuring shafts		324 et seqq.	
Torsionally rigid couplings		312	
Torsionally stiff couplings	118 et seqq., 152 et seqq., 171 et seqq.		
Speed measuring shafts		324 et seqq.	
Shear type couplings		50, 51, 75	
Fail-safe shaft couplings	26 et seqq., 65, 108 et seqq., 122		
E			
Stainless steel couplings		43, 104	
Elastomer couplings	232 et seqq., 102, 118 et seqq., 214 et seqq., 222 et seqq.		
Use in potentially explosive atmospheres	11, 29, 87, 121, 181, 203, 231		
F			
Flange couplings		216 et seqq.	
Idle rotating couplings		252 - 261	
G			
All-steel gear couplings		110 et seqq.	
H			
Half shell drop-out center design couplings	48, 49, 51, 52, 100, 140, 144		
Hermetic sealing		228 et seqq.	
Highly flexible couplings	102, 216 et seqq.		
I			
Internal clamping sets		278 et seqq.	
K			
Jaw couplings	27 et seqq., 65 et seqq., 122 et seqq.		
Clamping hubs	46, 130, 132, 156, 154, 158, 171, 206		
Clamping system		150	
Taper clamping ring hubs	45, 134 et seqq., 160		
Taper clamping bushes		44, 68	
Corrosion protection	42, 43, 91, 104		
Ball ratchet couplings		252 et seqq.	
L			
Stock programme of finish bores		36, 90	
Lamina couplings		170, 182, 192	
M			
Magnetic couplings		228 et seqq.	
Metal bellow-type couplings		152 et seqq.	
Miniature couplings	42, 130 et seqq., 152 et seqq., 170, 176		
Miniature clamping sets		278 et seqq.	
N			
Flexible couplings	26 et seqq., 102, 118 et seqq., 216 et seqq., 224 et seqq.		
Cam couplings	30 et seqq., 65 et seqq., 122 et seqq.		
P			
Permanent-magnetic couplings		228 et seqq.	
Precision couplings	118 et seqq., 148 et seqq., 170 et seqq., 176 et seqq.		
Precision joints		316 et seqq.	
R			
Ratchet couplings		252 et seqq.	
Torque limiters		246 et seqq.	
S			
Shifting hubs		59, 96 et seqq., 117	
Servo couplings	118 et seqq., 152 et seqq., 170 et seqq., 176 et seqq.		
Servo lamina couplings		170 et seqq.	
Safety couplings		242 ff.	
Spacer couplings	51 et seqq., 72, 75, 112, 146 et seqq., 186 et seqq.		
Clamping sleeves		290	
Clamping nuts		315	
Clamping ring hubs	45, 134 et seqq., 160, 174		
Clamping sets		278 et seqq.	
Safety couplings with retaining elements		252 et seqq.	
Backlash-free couplings	118 et seqq., 152 et seqq., 170 et seqq., 176 et seqq., 182 et seqq., 193 et seqq.		
Steel lamina couplings		170, 182, 193	
Steel shaft couplings	108 et seqq., 156 - 159, 178 et seqq.		
Rigid shaft couplings		312	
T			
Taper clamping sleeves		44, 68	
U			
Overload couplings/Overload systems		242 et seqq.	
Universal clamping sets		278 et seqq.	
W			
Shaft-hub-connections		278 et seqq.	
Precision joints		316 et seqq.	
Shaft couplings	30 et seqq., 65 et seqq., 73 et seqq., 77 et seqq., 88 et seqq., 108 et seqq., 122 et seqq., 152 et seqq., 170-175, 182 et seqq., 193 et seqq., 232 et seqq.		
Z			
Spiders		32, 65, 123	
Spider hardness		32, 65, 123	
Gear couplings	84 et seqq., 108 et seqq., 208 et seqq.		
Intermediate shafts	55, 101, 114, 146-149, 168-169, 188		

Summary of Products

Couplings	
Flexible jaw and pin & bush couplings	26
Gear couplings	84
Backlash-free servo couplings	118
Steel lamina couplings	178
Flange couplings	200
Magnetic couplings	228
Hydraulic clamping system	
Safety clamping and brake system	150
Torque limiters	
Torque limiters	246
Overload systems	246
Backlash-free overload systems	262
Clamping elements and precision joints	
Clamping sets	278
Clamping nut	315
Precision joints	316
Torque measuring technology	
Torque measuring shafts	324



COUPLING SELECTION ACCORDING TO DIN 740 PART II

Coupling types

Flexible jaw couplings

ROTEX®



Flexible coupling (see page 28)

- Flexible
- Maintenance-free
- Fail-safe
- Compact dimensions
- Axial plug-in

POLY-NORM®



Flexible coupling (see page 28)

- Flexible
- Maintenance-free
- Fail-safe
- Compact dimensions
- Axial plug-in

POLY



Flexible, shear type coupling (see page 28)

- Flexible
- Maintenance-free
- Shear type
- Axial plug-in

Gear couplings

BoWex®



Torsionally rigid curved-tooth gear coupling* (see page 86)

- Torsionally rigid
- Maintenance-free
- Shear type
- Compact dimensions
- Single-cardanic or double-cardanic
- Axial plug-in

BoWex® HEW Compact



Highly flexible shaft coupling (see page 86)

- Highly flexible
- Maintenance-free
- Shear type
- Compact dimensions
- Single-cardanic
- Axial plug-in

Flange couplings for I. C.-engines

BoWex-ELASTIC®



Highly flexible flange coupling (see page 202)

- Flexible to highly flexible
- Maintenance-free
- Shear type
- Compact dimensions
- Single-cardanic
- Axial plug-in

MONOLASTIC®



One-piece, flexible flange coupling (see page 202)

- Flexible
- Maintenance-free
- Shear type
- Compact dimensions
- Single-cardanic
- Axial plug-in

BoWex® FLE-PA/-PAC



Torsionally rigid flange coupling (see page 202)

- Torsionally rigid
- Maintenance-free
- Shear type
- Compact dimensions
- Single-cardanic
- Axial plug-in

COUPLING SELECTION ACCORDING TO DIN 740 PART II

Terminology of coupling selection

Description	Symbol	Definition or explanation
Rated torque of coupling [Nm]	T_{KN}	Torque that can be continuously transmitted over the entire permissible speed range
Maximum torque of coupling [Nm]	$T_{K\ max}$	Torque that can be transmitted as dynamic load $\geq 10^5$ times or $5 \cdot 10^4$ as vibratory load, respectively, over the entire operating life of the coupling
Vibratory torque of coupling [Nm]	T_{KW}	Torque amplitude of the permissible periodical torque fluctuation with a frequency of 10 Hz and a basic load of T_{KN} or dynamic load up to T_{KN} , respectively
Damping power of coupling [W]	P_{KW}	Permissible damping power with an ambient temperature of +30 °C
Rated torque of machine [Nm]	T_N	Stationary rated torque on the coupling
Rated torque of driving side [Nm]	T_{AN}	on Rated torque of machine, calculated on the basis of rated power and rated speed
Rated torque of load side [Nm]	T_{LN}	Maximum figure of the load torque calculated on the basis of power and speed
Peak torque of machine [Nm]	T_S	Peak torque on the coupling
Peak torque of driving side [Nm]	T_{AS}	Peak torque with torque shock on driving side, e. g. tilting moment of the electric motor
Peak torque of load side [Nm]	T_{LS}	Peak torque with torque shock on load side, e. g. braking
Vibratory torque of machine [Nm]	T_W	Amplitude of the vibratory torque effective on the coupling

Description	Symbol	Definition or explanation
Damping power of machine [W]	P_W	Damping power which is effective on the coupling due to the load generated by the vibratory torque
Engine power [kW]	P	Rated power of drive
Speed [rpm]	n	Rated speed of engine
Rotational inertia coefficient of driving side	M_A	Factor considering the mass distribution with shocks and vibrations generated on the driving or load side
Rotational inertia coefficient of load side	M_L	
Mass moment of inertia of driving side [kgm ²]	J_A	Total of moments of inertia existing on the driving or load side referring to the coupling speed
Mass moment of inertia of load side [kgm ²]	J_L	
Mass moment of inertia of coupling [kgm ²]	J_{KA}	Mass mom. of inertia of the coupl. half on drive side
	J_{KL}	Mass mom. of inertia of the coupl. half on load side
Starting factor	S_Z	Factor considering the additional load caused by the starting frequency per minute
Shock factor on driving side	S_A	Factor considering the shocks arising depending on the application (e. g. starting shocks)
Shock factor on load side	S_L	
Temperature factor	S_t	Factor considering the lower loading capacity or larger deformation of an elastomer part under load particularly in case of increased temperatures
Operating factor	S_B	Factor considering the different demands on the coupling dependent on the application
Screw tightening torque [Nm]	T_A	Tightening torque of screw

Temperature factor S_t												
	-50 °C	-30 °C/+30 °C	≤ +40 °C	≤ +50 °C	≤ +60 °C	≤ +70 °C	≤ +80 °C	≤ +90 °C	≤ +100 °C	≤ +110 °C	≤ +120 °C	
ROTEX®												
T-PUR®	1.0	1.0	1.1	1.2	1.3	1.45	1.6	1.8	2.1	2.5	3.0	
PUR	-	1.0	1.2	1.3	1.4	1.55	1.8	2.2	-	-	-	
POLY-NORM®												
NBR 78 Shore A	-	1.0	1.2	1.3	1.4	1.6	1.8	-	-	-	-	
POLY												
NBR (cuboid)	-	1.0	1.2	1.3	1.4	1.6	1.8	-	-	-	-	
BoWex®												
PA 6.6	1.0	1.0	1.0	1.0	1.0	1.2	1.4	1.6	1.8	-	-	
PA-CF	1.0	1.0	1.0	1.0	1.0	1.1	1.2	1.4	1.6	1.9	2.2	
BoWex® HEW Compact	-	1.0	1.0	1.0	1.0	1.1	1.4	1.7	-	-	-	
BoWex-ELASTIC®												
Standard	-	1.0	1.0	1.0	1.0	1.2	1.6	-	-	-	-	
Thermally stable comp.*	-	1.0	1.0	1.0	1.0	1.1	1.4	1.7	-	-	-	
MONOLASTIC®												
Standard	-	1.0	1.0	1.0	1.0	1.2	1.6	-	-	-	-	
BoWex® FLE-PA/-PAC												
PA 6 GF	1.0	1.0	1.0	1.0	1.0	1.0	1.0	1.2	1.4	1.6	1.8	
PA-CF	1.0	1.0	1.0	1.0	1.0	1.0	1.1	1.2	1.4	1.6	1.9	

* Thermally stable compound is marked with „T“ in front of hardness (e. g. T 50 Shore).
For the selection with PEEK spider a temperature factor is not necessary.
For temperature factors for PA spiders see page 30.

Starting factor S_Z				
ROTEX®, POLY-NORM®, POLY, BoWex®, BoWex® HEW Compact				
Starting frequency per hour	< 100	< 200	< 400	< 800
S_Z	1.0	1.2	1.4	1.6
BoWex-ELASTIC®				
Starting frequency per hour	< 10	< 60	< 120	> 120
S_Z	1.0	1.5	2.0	On request

Shock factor S_A/S_L	
ROTEX®, POLY-NORM®, POLY, BoWex®, BoWex® HEW Compact, BoWex-ELASTIC®	
	S_A/S_L
Moderate shocks	1.5
Average shocks	1.8
Heavy shocks	2.5

Operating factor S_B	
Hydrostatic drives for BoWex® FLE-PA, MONOLASTIC®	
Applications	S_B
Wheel loaders	1.6
Compact loaders	1.6
Hydraulic excavators	1.4
Mobile cranes	1.6
Graders	1.5
Vibration rollers	1.4
Forklift trucks	1.6
Concrete mixer trucks	1.3
Concrete pumps	1.4
Asphalt finishers	1.4
Concrete cutters	1.4
Road milling machines	1.4

Permissible load on feather keyway of the coupling hubs

The shaft-hub-connection needs to be reviewed by the customer.

Permissible surface pressure according to DIN 6892 (method C)			
Cast iron (GJL)	225 N/mm ²	Powder metal steel	180 N/mm ²
Nodular iron (GJS)	225 N/mm ²	Aluminium diecast (Al-D)	110 N/mm ²
Steel	250 N/mm ²	Aluminium wrought products (Al-H)	200 N/mm ²
Polyamide	30 N/mm ² (up to +40 °C)	For other steel materials pperm.	0.9 • R_e ($R_{p0.2}$)

COUPLING SELECTION ACCORDING TO DIN 740 PART II

Coupling selection

The coupling selection is based on DIN 740 part 2. The coupling has to be dimensioned in a way that the permissible coupling load is not exceeded during any operating condition. For this purpose the actual loads have to be compared to the permissible parameters of the coupling. The torques specified $T_{KN}/T_{K\ max}$ refer to the couplings. The shaft-hub-connection needs to be reviewed by the customer.

1. Drives without periodical torsional vibrations

For example centrifugal pumps, fans, screw compressors, etc. The coupling selection is based on reviewing the rated torque T_{KN} and the maximum torque $T_{K\ max}$.

1.1 Loading generated by rated torque

Considering the ambient temperature the permissible rated torque T_{KN} of the coupling must at least equal the rated torque of the machine T_N .

$$T_N [Nm] = 9550 \cdot \frac{P [kW]}{n [rpm]}$$

$$T_{KN} \geq T_N \cdot S_t$$

1.2 Loading generated by torque shocks

The permissible maximum torque of the coupling $T_{K\ max}$ must at least equal the sum of the peak torque T_S and rated torque of the machine T_N taking into account the shock frequency S_Z and the ambient temperature S_t . This applies in case if the rated torque of the machine T_N is superimposed by a shock process. Knowing the mass distribution, direction and kind of shock it is possible to calculate the peak torque T_S . For drives with A. C. motors and big masses on the load side we recommend to run a calculation of the peak starting torque by our simulation program.

$$T_{K\ max} \geq T_S \cdot S_Z \cdot S_t + T_N \cdot S_t$$

$$\text{Shock on drive side} \\ T_S = T_{AS} \cdot M_A \cdot S_A$$

$$\text{Shock on load side} \\ T_S = T_{LS} \cdot M_L \cdot S_L$$

$$M_A = \frac{J_L}{(J_A + J_L)}$$

$$M_L = \frac{J_A}{(J_A + J_L)}$$

2. Drives with periodical torsional vibrations

For drives subject to torsional vibrations, e. g. diesel engines, piston compressors, piston pumps, generators etc. it is necessary to perform a torsional vibration calculation for a selection ensuring a safe operation. If requested, we will perform the torsional vibration calculation and the coupling selection in our company. For the necessary details refer to KTR standard 20004.

2.1 Loading generated by rated torque

Considering the ambient temperature the permissible rated torque T_{KN} of the coupling must at least equal the rated torque of the machine T_N .

$$T_{KN} \geq T_N \cdot S_t$$

2.2 Passing through the resonance range

Considering the temperature the peak torque T_S arising when passing through the resonance range must not exceed the maximum torque $T_{K\ max}$ of the coupling.

$$T_{K\ max} \geq T_S \cdot S_t$$

2.3 Loading generated by vibratory torque shocks

Considering the ambient temperature the permissible vibratory torque T_{KW} of the coupling must not be exceeded by the biggest periodical vibratory torque T_{W} with operating speed. With higher operating frequencies $f > 10$ Hz the heat generated by damping in the elastomer is considered as damping power P_{W} . The permissible damping power P_{KW} of the coupling depends on the ambient temperature and must not be exceeded by the damping power generated.

$$T_{KW} \geq T_W \cdot S_t$$

$$P_{KW} \geq P_W$$

With torsionally rigid couplings the damping power can be ignored.

Coupling selection of BoWex® FLE-PA and MONOLASTIC®

1 Loading generated by rated torque

For drives with small mass moments of inertia on the load side (hydrostatic drives) the selection can be simplified using operating factors.

$$T_{KN} \geq T_N \cdot S_B \cdot S_t$$

Please note:

For drives subject to torsional vibrations, e. g. diesel engines, piston compressors, piston pumps, generators etc. it is necessary to perform a torsional vibration calculation for a selection ensuring a safe operation. This applies in particular with large mass moments of inertia on the load side. If requested, we will perform the torsional vibration calculation and the coupling selection in our company.

COUPLING SELECTION ACCORDING TO DIN 740 PART II

Example of calculation

Requested: Axial plug-in coupling damping vibrations → ROTEX®
 Application: Connection of IEC standard motor and screw compressor
 → Coupling selection following page 16, item 1: Drives without periodical torsional vibrations

Given: Details of driving side

A. C. motor: Size 315 L → $S_A = 1.8$ (see page 15)
 Motor power: $P = 160$ kW
 Speed: $n = 1485$ rpm
 Moment of inertia of driving side: $J_{Motor} = 2.9$ kgm²
 Starting frequency: 6 times per hour → $S_Z = 1.0$ (see page 15)
 Ambient temperature: +70 °C → $S_t = 1.45$ using T-PUR® (see page 15)
 Peak torque (starting torque) $T_{AS} = 2 \cdot T_{AN}$

Given: Details of load side

Screw compressor
 Rated torque of load side: $T_{LN} = 930$ Nm
 Moment of inertia of load side: $J_{Compressor} = 6.8$ kgm²

Calculation

1.1 Loading generated by rated torque

- Rated torque of drive T_{AN}

$$T_{AN} = 9550 \cdot \frac{P [kW]}{n [rpm]} \rightarrow 9550 \cdot \frac{160 \text{ kW}}{1485 \text{ rpm}} = 1029 \text{ Nm}$$
- Rated torque of load side T_{LN}

$$T_{KN} \geq T_{LN} \cdot S_t \rightarrow 930 \text{ Nm} \cdot 1.45 = 1348.5 \text{ Nm} \rightarrow T_{KN} \geq 1348.5 \text{ Nm}$$
- Coupling selection
 ROTEX® size 90 - spider 92 Shore A with: Mass moments of inertia of page 63
 $T_{KN} = 2400$ Nm $J_{KA} = 0.0673$ kgm²
 $T_{K \max} = 4800$ Nm $J_{KL} = 0.0673$ kgm²

1.2 Loading generated by torque shocks

- Shock on driving side without load torque being superimposed

$$T_{K \max} \geq T_S \cdot S_Z \cdot S_t + T_N \cdot S_t \rightarrow T_N = 0$$

Shock on drive side $T_S = T_{AS} \cdot M_A \cdot S_A$

$$M_A = \frac{J_L}{(J_A + J_L)} \rightarrow \frac{6.8673 \text{ kgm}^2}{2.9673 \text{ kgm}^2 + 6.8673 \text{ kgm}^2} \rightarrow M_A = 0.7$$

$$J_A = J_{Motor} + J_{KA} \rightarrow 2.9 \text{ kgm}^2 + 0.0673 \text{ kgm}^2 \rightarrow J_A = 2.9673 \text{ kgm}^2$$

$$J_L = J_{Compressor} + J_{KL} \rightarrow 6.8 \text{ kgm}^2 + 0.0673 \text{ kgm}^2 \rightarrow J_L = 6.8673 \text{ kgm}^2$$

Starting torque $T_{AS} = 2 \cdot T_{AN} \rightarrow 2 \cdot 1029 \text{ Nm} = 2058 \text{ Nm}$

$$\rightarrow \text{Shock on drive side } T_S = 2058 \cdot 0.7 \cdot 1.8 = 2593.1 \text{ Nm}$$

$$\rightarrow T_{K \max} \geq 2593.1 \text{ Nm} \cdot 1 \cdot 1.45 = 3760 \text{ Nm}$$

$T_{K \max}$ with 4800 Nm ≥ 3760 Nm ✓

Result

The coupling is sufficiently dimensioned.

Please note:

The shaft-hub-connection has to be verified by the customer separately!

COUPLING SELECTION BASED ON OPERATING FACTORS

Coupling types

Lamina couplings

RADEX®-N Steel lamina coupling (see page 180)



- Torsionally rigid
- Backlash-free
- Maintenance-free
- Compact dimensions
- Single-cardanic or double-cardanic
- All-steel

RIGIFLEX®-N Steel lamina coupling (see page 180)



- Torsionally rigid
- Backlash-free
- Maintenance-free
- Double-cardanic
- All-steel
- Coupling in accordance with API 610, API 671 optionally

RIGIFLEX®-HP High-performance steel lamina coupling (see page 180)



- Torsionally rigid
- Backlash-free
- Maintenance-free
- Double-cardanic
- All-steel
- Coupling design as per API 671

Pin & bush couplings

REVOLEX® KX-D Flexible pin & bush coupling (see page 28)



- Flexible
- Maintenance-free
- Fail-safe
- Compact dimensions
- Axial plug-in

Gear couplings

GEARex® All-steel gear coupling (see page 86)



- Torsionally rigid
- Fail-safe
- Compact dimensions
- Double-cardanic
- High power density
- All-steel

Terminology of coupling selection

Description	Symbol	Definition or explanation
Rated torque of coupling [Nm]	T_{KN}	Torque that can be continuously transmitted over the entire permissible speed range
Maximum torque of coupling [Nm]	T_{Kmax}	Torque that can be transmitted as dynamic load $\geq 10^5$ times or $5 \cdot 10^4$ as vibratory load, respectively, over the entire operating life of the coupling
Vibratory torque of coupling [Nm]	T_{KW}	Torque amplitude of the permissible periodical torque fluctuation with a frequency of 10 Hz and a basic load of T_{KN} or dynamic load up to T_{KN} , respectively
Rated torque of machine [Nm]	T_N	Stationary rated torque on the coupling
Peak torque of machine [Nm]	T_S	Peak torque on the coupling

Description	Symbol	Definition or explanation
Engine power [kW]	P	Rated power of drive
Speed [rpm]	n	Rated speed of engine
Starting factor	S_Z	Factor considering the additional load caused by the starting frequency per hour
Direction factor	S_R	Considers the torsional direction
Temperature factor	S_t	Factor considering the lower loading capacity particularly in case of increased temperatures
Operating factor	S_B	Factor considering the different demands on the coupling dependent on the application

COUPLING SELECTION BASED ON OPERATING FACTORS

Factors

Temperature factor S_t								
	-30 °C/ +30 °C	≤ +40 °C	≤ +60 °C	≤ +80 °C	≤ +150 °C	≤ +200 °C	≤ +230 °C	≤ +270 °C
REVOLEX® KX-D	1.0	1.2	1.4	1.8	-	-	-	-
GEARex®	1.0	1.0	1.0	1.0	-	-	-	-
RADEX®-N, RIGIFLEX®-N, RIGIFLEX®-HP	1.0	1.0	1.0	1.0	1.0	1.10	1.25	1.43

Starting factor S_z				Direction factor S_R	
Starting frequency per hour	< 10	< 25	< 50	Same torsional direction	
S_z	1.0	1.2	1.4	Alternating torsional direction	
				1.0	
				1.7	

Operating factor S_B			
Application		Application	
Construction machines		Mixers	
Manoeuvre hoists	1.50 - 2.00	Constant density	1.75 - 2.25
Swing gears	1.50 - 2.00	Variable density	2.00 - 2.50
Miscellaneous winches	1.50 - 2.00	Grinders	
Filters, cable winches	1.75 - 2.25	Centrifugal mills	1.75 - 2.00
Multi-bucket excavators	1.75 - 2.25	Beater mills	1.75 - 2.00
Running gears (caterpillars)	1.75 - 2.25	Autogenous mills	1.75 - 2.00
Impellers	1.75 - 2.25	Hammer and ball mills	2.00 - 2.50
Cutter drives	2.00 - 2.50	Food industry	
Elevators	1.50 - 2.00	Sugarcane harvesters	1.25 - 1.50
Conveyors		Sugar-beet harvesters	1.25 - 1.50
Bucket elevators	1.50 - 2.00	Sugar-beet washing	1.25 - 1.50
Elevators	1.75 - 2.25	Kneading machines	1.75 - 2.00
Hauling winches	1.50 - 2.00	Sugarcane breakers	1.75 - 2.00
Apron conveyors	1.25 - 1.75	Sugarcane mills	1.75 - 2.00
Rubber belt conveyors (bulk)	1.25 - 1.75	Oil industry	
Boom plate bucket conveyors	1.25 - 1.75	Filter presses for paraffin	1.50 - 2.00
Rotary conveyors	1.50 - 1.75	Rotary furnaces	1.75 - 2.00
Steel plate conveyors	1.50 - 1.75	Paper machines	
Worm conveyors	1.25 - 1.50	Couch rolls	1.75 - 2.25
Steel belt conveyors	1.75 - 2.00	Calanders	1.75 - 2.25
Conveyors	1.75 - 2.00	Wet presses	1.75 - 2.25
Rubber belt conveyors (bulk)	1.75 - 2.00	Pumps	
Inclined lifts	1.75 - 2.00	Radial pumps	1.25 - 1.75
Shaking slides	2.00 - 2.25	Centrifugal pumps (light liquid)	1.50 - 2.00
Generators		Centrifugal pumps (viscous liquid)	2.25 - 2.50
Frequency converters	1.75 - 2.00	Gear and vane pumps	1.50 - 1.75
Generators	1.50 - 2.00	Piston pumps, plunger pumps and press pumps	2.00 - 2.50
Rubber & nylon industry		Agitators	
Rubber calanders and rolling mills	1.25 - 2.00	Light liquid	1.25 - 1.50
Mixers	1.25 - 2.00	Viscous liquid	1.50 - 1.75
Extruders	1.25 - 2.00	Liquid with constant density	1.25 - 1.50
Lifters/cranes		Liquid with variable density	1.50 - 2.00
Bridge cranes for steel industry	2.00 - 2.25	Textile industry	
Cranes (heavy load operation)	2.00 - 2.25	Winders	1.25 - 1.75
Running gears	1.75 - 2.25	Printing and dyeing machines	1.25 - 1.75
Lifting gears	1.75 - 2.25	Shredders	1.50 - 2.00
Woodworking machinery		Fans, ventilators and blowers	
Planing machines	1.50 - 1.75	Light-weight fans	1.25 - 1.75
Barking machines	1.75 - 2.00	Large fans	1.75 - 2.50
Saw frames	1.75 - 2.00	Centrifugal fans	1.25 - 1.50
Compressors		Industrial fans	1.25 - 1.50
Centrifugal compressors	1.50 - 2.00	Rotary blowers	1.25 - 1.75
Rotary compressors	1.50 - 2.00	Fans (axial/radial)	1.25 - 1.75
Turbo compressors	2.00 - 2.50	Fans for cooling towers	1.50 - 2.00
Piston compressors	2.50 - 3.00	Wastewater treatment plants	
Metal industry		Rakes	1.25 - 1.50
Wire pulls	1.25 - 1.50	Worm pumps	1.25 - 1.50
Winders	1.25 - 1.50	Concentrators	1.25 - 1.50
Winding drums	1.50 - 2.00	Mixers	1.25 - 1.75
Wire drawing machines	2.00 - 2.50	Aerators	1.75 - 2.00
Plate shears	2.00 - 2.50	Machine tools	
Block pushers	2.00 - 2.50	Scissors	1.50 - 2.00
Blooming and slabbing	2.00 - 2.50	Dressing rollers	1.50 - 2.00
De-scalers	2.00 - 2.50	Bending machines	1.50 - 2.00
Hot-rolling mills	2.00 - 2.50	Hole punching machines	1.75 - 2.50
Cold-rolling mills	2.00 - 2.50	Levelling machines	1.75 - 2.50
Billet shears	2.00 - 2.50	Hammers	1.75 - 2.50
Plugging machines	2.00 - 2.50	Presses	1.75 - 2.50
Continuous casting machines	2.00 - 2.50	Forging presses	1.75 - 2.50
Shifting devices	2.00 - 2.50	Other	
Application	2.00 - 2.50	Equipment for transport of persons	2.00 - 2.50
Roller tables (heavy-weight)	2.00 - 2.50	Rock crushers	2.50 - 3.00
Mixers		Rolling mill drives	2.00 - 2.50
Constant density	1.75 - 2.25		
Variable density	2.00 - 2.50		

COUPLING SELECTION BASED ON OPERATING FACTORS

Coupling selection

The coupling selection is based on operating factors. The coupling has to be dimensioned in a way that the permissible coupling load is not exceeded during any operating condition. For this purpose the actual loads have to be compared to the permissible parameters of the coupling. The shaft-hub-connection needs to be reviewed by the customer.

1. Drives without periodical torsional vibrations

For example centrifugal pumps, fans, screw compressors, etc. The coupling selection is based on reviewing the rated torque T_{KN} and the maximum torque $T_{K\max}$.

1.1 Loading generated by rated torque

Considering the operating factor, the ambient temperature and the torsional direction, the permissible rated torque T_{KN} of the coupling must at least equal the rated torque of the machine T_N .

$$T_N [Nm] = 9550 \cdot \frac{P [kW]}{n [rpm]}$$

$$T_{KN} \geq T_N \cdot S_B \cdot S_t \cdot S_R$$

1.2 Loading generated by torque shocks

Taking into account all relevant factors, the permissible maximum torque of the coupling $T_{K\max}$ must at least equal the sum of the peak torque T_S and rated torque of the machine T_N . This applies if the rated torque of the machine T_N is superimposed by a shock process. For drives with A. C. motors and big masses on the load side we recommend to run a calculation of the peak starting torque by our simulation program.

$$T_{K\max} \geq (T_N + T_S) \cdot S_Z \cdot S_t \cdot S_R$$

2. Drives with periodical torsional vibrations

For drives subject to torsional vibrations, e. g. diesel engines, piston compressors, piston pumps, generators etc. it is necessary to perform a torsional vibration calculation for a selection ensuring a safe operation. If requested, we will perform the torsional vibration calculation and the coupling selection in our company. For the necessary details refer to KTR standard 20004.

COUPLING SELECTION BASED ON OPERATING FACTORS

Example of calculation

Requested: Double-cardanic steel lamina coupling for bridging a shaft distance dimension → RADEX®-N
Application: Connection of IEC standard motor and radial pump
 → Coupling selection following page 20, item 1: Drives without periodical torsional vibrations

Given: Details of driving side

A. C. motor: Size 315 L
 Motor power: $P = 200 \text{ kW}$
 Speed: $n = 1500 \text{ rpm}$
 Starting frequency: 6 times per hour → $S_Z = 1.0$ (see page 19)
 Ambient temperature: $+65 \text{ °C}$ → $S_t = 1.0$ (see page 19)
 Peak torque (starting torque) $T_{AS} = 2 \cdot T_{AN}$
 Diameter of motor shaft: 80 mm

Given: Details of load side

Radial pump → $S_B = 1.5$ (see page 19)
 Rated torque of load side: $T_{LN} = 930 \text{ Nm}$
 Diameter of pump shaft: 75 mm
 Distance dimension of motor shaft - pump shaft (DBSE) = 250 mm
 Direction of torque: same → $S_R = 1.0$ (see page 19)

Calculation

1.1 Loading generated by rated torque

● Rated torque of drive T_{AN}

$$T_{AN} = 9550 \cdot \frac{P [\text{kW}]}{n [\text{rpm}]} \rightarrow 9550 \cdot \frac{200 \text{ kW}}{1500 \text{ rpm}} = \underline{1273 \text{ Nm}}$$

● Loading generated by rated torque

$$T_{KN} \geq T_{AN} \cdot S_B \cdot S_t \cdot S_R \rightarrow 1273 \text{ Nm} \cdot 1.5 \cdot 1 \cdot 1 = 1909.5 \text{ Nm} \rightarrow T_{KN} \geq \underline{1909.5 \text{ Nm}}$$

1.2 Loading generated by torque shocks

● Shock on driving side without load torque being superimposed

$$T_{K \max} \geq (T_N + T_S) \cdot S_Z \cdot S_t \cdot S_R \rightarrow T_N = 0$$

$$\rightarrow \text{Starting torque } T_{AS} = 2 \cdot T_{AN} \rightarrow 2 \cdot 930 \text{ Nm} = \underline{1860 \text{ Nm}}$$

$$\rightarrow T_{K \max} \geq 1860 \text{ Nm} \cdot 1 \cdot 1 \cdot 1 = \underline{1860 \text{ Nm}}$$

● Coupling selection

$$T_{KN} = 2400 \text{ Nm}$$

$$T_{K \max} = 4800 \text{ Nm}$$

Result

The coupling is sufficiently dimensioned.

Please note:

The shaft-hub-connection has to be verified by the customer separately!

COUPLING SELECTION ACCORDING TO DIN 740 PART II WITH SPECIFIC FACTORS

Coupling types

Backlash-free servo couplings

ROTEX® GS



Backlash-free, flexible jaw coupling (see page 120)

- Backlash-free and flexible
- Maintenance-free
- Fail-safe
- Compact dimensions, high power density
- Single-cardanic or double-cardanic
- Axial plug-in
- High speeds

TOOLFLEX®



Backlash-free, torsionally rigid metal bellow-type coupling (see page 120)

- Backlash-free and torsionally rigid
- Maintenance-free
- Shear type
- Compact dimensions
- Double-cardanic
- Axial plug-in (as an option)
- All-steel

RADEX®-NC



Backlash-free, torsionally rigid servo lamina coupling (see page 120)

- Backlash-free and torsionally rigid
- Maintenance-free
- Compact dimensions
- Single-cardanic or double-cardanic
- All-steel

COUNTEX®



Backlash-free, torsionally rigid shaft encoder coupling (see page 120)

- Backlash-free and torsionally rigid
- Maintenance-free
- Compact dimensions
- Double-cardanic
- Axial plug-in

Terminology of coupling selection

Description	Symbol	Definition or explanation
Rated torque of coupling [Nm]	T_{KN}	Torque which can be continuously transmitted over the entire permissible speed range, taking into account the factors
Maximum torque of coupling [Nm]	$T_{K\ max}$	Torque which can be transmitted over the entire service life of the coupling as dynamic load $\geq 10^5$ or vibratory load $5 \cdot 10^4$ taking into account the factors
Rated torque of machine [Nm]	T_N	Stationary rated torque on the coupling
Rated torque of driving side [Nm]	T_{AN}	Constantly occurring driving torque as per the data indicated by the motor manufacturer
Peak torque [Nm]	T_S	Peak torque on the coupling
Peak torque of driving side [Nm]	T_{AS}	Peak torque with torque shock on driving side, e. g. starting torque of the servo motor as per the data specified by the motor manufacturer
Peak torque of load side [Nm]	T_{LS}	Peak torque with torque shock on load side, e. g. braking
Screw tightening torque [Nm]	T_A	Tightening torque of screw
Friction torque [Nm]	T_R	Torque that can be transmitted through the frictionally engaged shaft-hub-connection

Description	Symbol	Definition or explanation
Rotational inertia coefficient of driving side	M_A	Factor considering the mass distribution with shocks and vibrations generated on the driving or load side
Rotational inertia coefficient of load side	M_L	
Mass moment of inertia of driving side [kgm ²]	J_A	Total of moments of inertia existing on the driving or load side referring to the coupling speed
Mass moment of inertia of load side [kgm ²]	J_L	
Mass moment of inertia of coupling [kgm ²]	J_{KA}	Mass mom. of inertia of the coupl. half on drive side
	J_{KL}	Mass mom. of inertia of the coupl. half on load side
Mass moment of inertia [kgm ²]	$J_{Mot}/J_{Sp}/J_{HS}$	Mass moment of inertia of the motor/mass moment of inertia of the spindle/mass moment of inertia of the main spindle
Temperature factor	S_t	Factor considering the lower loading capacity or larger deformation of an elastomer part under load particularly with increased temperatures
Operating factor	S_B	Factor considering the different demands on the coupling dependent on the application

COUPLING SELECTION ACCORDING TO DIN 740 PART II WITH SPECIFIC FACTORS

Factors

Temperature factor S_t														
	-50 °C	-40 °C	-30 °C	-20 °C/ +30 °C	≤ +40 °C	≤ +50 °C	≤ +60 °C	≤ +70 °C	≤ +80 °C	≤ +90 °C	≤ +100 °C	≤ +110 °C	≤ +120 °C	≤ +200 °C
ROTEX® GS														
Polyurethane 80 ShA-GS	1.0	1.0	1.0	1.0	1.2	1.3	1.4	1.55	1.8	-	-	-	-	-
Polyurethane 92 ShA-GS	-	1.0	1.0	1.0	1.2	1.3	1.4	1.55	1.8	2.2	-	-	-	-
Polyurethane 98 ShA-GS	-	-	1.0	1.0	1.2	1.3	1.4	1.55	1.8	2.2	-	-	-	-
Polyurethane 64 ShD-GS	-	-	-	1.0	1.2	1.3	1.4	1.55	1.8	2.2	3.0	3.0	-	-
Polyurethane 72 ShD-GS	-	-	-	1.0	1.2	1.3	1.4	1.55	1.8	2.2	3.0	3.0	-	-
Hytrel 64 ShD-H-GS	1.0	1.0	1.0	1.0	1.2	1.3	1.4	1.5	1.6	1.8	2.0	2.3	2.8	-
Hytrel 72 ShD-H-GS	1.0	1.0	1.0	1.0	1.2	1.3	1.4	1.5	1.6	1.8	2.0	2.3	2.8	-
TOOLFLEX®														
Size 5 to 12	-	-	1.0	1.0	1.0	1.0	1.0	1.0	1.0	1.0	1.0	-	-	-
Size 16 to 65	-	-	1.0	1.0	1.0	1.0	1.0	1.0	1.0	1.0	1.0	1.0	1.0	1.1
RADEX-NC®														
EK and DK	-	-	1.0	1.0	1.0	1.0	1.0	1.0	1.0	1.0	1.0	1.0	1.0	1.1

Operating factor S_B		
ROTEX® GS*		
Backlash-free drives		
Main spindle drive of machine tools		
Moderate shocks	Grinders, small milling machines/drills	2.0 - 5.0
Average shocks	Milling machines/drills with interrupted cut	1.6 - 2.4
Heavy shocks	Fly cutters etc.	2.4 - 3.0
Positioning drives		
Ball screw drive/toothed belt drive		
Gearbox		
i 3 - ≤ 5		2.5 - 4.0
i > 5 - ≤ 7		8.0
i > 7		5.0
Servo-hydraulic drives		
With pulsating load ¹⁾		3.0
With alternating load ²⁾		1.2 - 1.3
TOOLFLEX®, RADEX®-NC		
Uniform motion		1.3 - 1.5
Unequal motion		2.0
Shock motion		2.5 - 4.0
For drives on machine tools (servo motors) values from 1.5 - 2.0 must be used.		
Starting factor S_z		
Starting frequency per minute		
< 20		1.0
< 60		1.2
< 120		1.4
< 180		1.6
< 240		1.8
> 240		2.0

* When using the spider 64 ShD-GS or 72 ShD-GS a minimum factor of 4 or steel hubs have to be used.

¹⁾ With dynamic load the use of aluminium is permissible.

²⁾ With vibratory load please make use of steel hubs.

Shaft encoder drives: Subject to the low torques to be transmitted the coupling size for shaft encoder drives is selected according to the shaft diameters to be connected.

Coupling selection

The coupling selection of the backlash-free servo couplings is based on DIN 740 part 2, but with specific factors. The coupling has to be dimensioned in a way that the permissible coupling load is not exceeded during any operating condition. For this purpose the actual loads have to be compared to the permissible parameters of the coupling. The shaft-hub-connection needs to be reviewed by the customer. The size of the coupling must be selected such that the following conditions are met.

1. Backlash-free drives

$$T_{KN} \geq T_N \cdot S_t \cdot S_B \quad \text{and} \quad T_{KN} \geq T_S \cdot S_t \cdot S_B$$

$$\text{In case of load torque: } T_{KN} \geq T_S \cdot S_t \cdot S_B + T_N \cdot S_t$$

Considering the ambient temperature and the operating factor, the permissible rated torque T_{KN} of the coupling must at least equal the rated torque of the machine T_N .

Considering the ambient temperature and the operating factor, the permissible rated torque T_{KN} of the coupling must at least equal the peak torque arising.

The following applies for the peak torque T_S :

$$T_S = T_{AS} \cdot M_A \cdot S_z \quad \rightarrow \quad M_A = \frac{J_L}{(J_A + J_L)}$$

2. Servo-hydraulic drives

$$T_{KN} \geq T_{AS} \cdot S_t \cdot S_B$$

Considering the ambient temperature and the operating factor, the permissible rated torque T_{KN} of the coupling must at least equal the peak torque of the driving side T_{AS} .

$S_t \cdot S_B$ with use of aluminium at least 1.5.

Please note:

For general applications (not backlash-free applications) please observe coupling selection according to DIN 740 part 2 (page 14 et seq.).

COUPLING SELECTION ACCORDING TO DIN 740 PART II WITH SPECIFIC FACTORS

Example of calculation for positioning drives

Requested: Backlash-free coupling damping vibrations

→ ROTEX® GS

Application: Connecting servo motor and ball screw drive for backlash-free positioning

→ Coupling selection following page 23, item 1: Backlash-free drives

Given: Details of driving side

Servo motor

Rated torque T_{AN} : 43 Nm
 Max. driving torque T_{AS} : 144 Nm
 Moment of inertia J_{Mot} : 0.0108 kgm²
 Diameter of motor shaft: 32 k6 without feather keyway

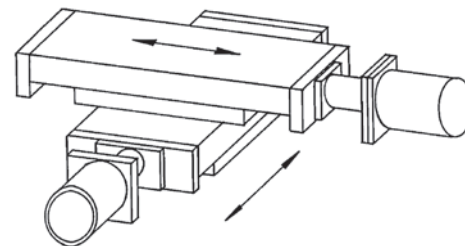

Ball screw

Ambient temperature: +40 °C

→ $S_t = 1.2$ (see page 23)

Starts per minute: 15

→ $S_z = 1.0$ (see page 23)

Given: Details of machine on driven side

Ball spindle J_{Sp} : 0.0038 kgm²
 Spindle pitch s : 10 mm
 Diameter of spindle shaft: 30 k6 without feather keyway
 Mass of slide + workpiece m_{Sj} : 1030 kg
 No load torque available

Required: High torsional stiffness

→ $S_B = 4$ (see page 23)

Calculation

1. Backlash-free drives

- Loading by rated torque (pre-selection)

$$T_{KN} \geq T_{AN} \cdot S_t \cdot S_B \quad \rightarrow 43 \text{ Nm} \cdot 1.2 \cdot 4 \quad \rightarrow T_{KN} \geq 206.4 \text{ Nm}$$

- Coupling selection (pre-selection)

ROTEX® GS 38

Spider 98 Shore A with clamping ring hubs 6.0 light:

Mass moments of inertia of page 136

$T_{KN} = 325 \text{ Nm}$

$J_{KA} = 0.000517 \text{ kgm}^2$

$T_{K \max} = 650 \text{ Nm}$

$J_{KL} = 0.000517 \text{ kgm}^2$

- Load by maximum driving torque, not including load torque

$$T_{KN} \geq T_S \cdot S_t \cdot S_B$$

$$\text{Shock on drive side} \quad T_S = T_{AS} \cdot M_A \cdot S_z \quad \rightarrow = 144 \text{ Nm} \cdot 0.379 \cdot 1.0 \quad \rightarrow T_S = 54.58 \text{ Nm}$$

$$M_A = \frac{J_L}{(J_A + J_L)} \quad \rightarrow = \frac{0.006917 \text{ kgm}^2}{(0.011317 \text{ kgm}^2 + 0.006917 \text{ kgm}^2)} \quad \rightarrow M_A = 0.379$$

$$J_L = J_{Sp} + J_{SI} + J_{KL} \quad \rightarrow 0.0038 \text{ kgm}^2 + 0.0026 \text{ kgm}^2 + 0.000517 \text{ kgm}^2 \rightarrow J_L = 0.006917 \text{ kgm}^2$$

$$J_A = J_{Mot} + J_{KL} \quad \rightarrow 0.0108 \text{ kgm}^2 + 0.000517 \text{ kgm}^2 \rightarrow J_A = 0.011317 \text{ kgm}^2$$

$$J_{SI} = m_{SI} \cdot \left(\frac{s}{2 \cdot \pi}\right)^2 \quad \rightarrow 1030 \text{ kg} \cdot \left(\frac{0.01}{2 \cdot \pi}\right)^2 \quad \rightarrow J_{SI} = 0.0026 \text{ kgm}^2$$

$$\rightarrow T_{KN} \geq 54.58 \text{ Nm} \cdot 1.2 \cdot 4 \rightarrow T_{KN} \geq 261.9 \text{ Nm}$$

T_{KN} with 325 Nm $\geq 261.9 \text{ Nm}$

- Review of shaft-hub-connection: Friction torque for clamping ring hubs type 6.0 light

The coupling has to be dimensioned such that the permissible friction torque is not exceeded during any operating condition.

$$T_R \geq T_{AS} \quad \text{values } T_R \text{ see page 130}$$

Friction torque of ROTEX® GS 38 clamping ring hub 6.0 light Ø30 H7/k6 $T_R = 563 \text{ Nm} > 144 \text{ Nm}$

Result

The coupling is sufficiently dimensioned.

COUPLING SELECTION ACCORDING TO DIN 740 PART II WITH SPECIFIC FACTORS

Example of calculation for main spindle drives

Requested: Backlash-free, axial plug-in coupling for high speeds → ROTEX® GS
 Application: Connecting servo motor and ball screw drive in grinding machine
 → Coupling selection following page 23, item 1: Backlash-free drives

Given: Details of driving side

Servo motor

max. continuous torque with machining T_{AN} : 130 Nm
 Max. driving torque T_{AS} : 190 Nm
 Max. speed: 6000 rpm
 Moment of inertia J_{Mot} : 0.316 kgm²
 Diameter of motor shaft: 38 k6 without feather key-way

Ambient temperature: +60 °C → $S_t = 1.4$ (see page 23)
 Starting factor S_z : < 20 rpm → $S_z = 1.0$ (see page 23)

Given: Details of machine on driven side

Moment of inertia of load side J_{HS} : 0.1094 kgm²
 Diameter of main spindle shaft: 30 k6 without feather key-way
 No load torque available

Required: Average shocks → $S_B = 2.4$ (see page 23)

Calculation

1. Backlash-free drives

● Loading by rated torque (machining torque) $T_{KN} \geq T_{AN} \cdot S_t \cdot S_B \rightarrow 130 \text{ Nm} \cdot 1.4 \cdot 2.4 \rightarrow T_{KN} \geq 436.8 \text{ Nm}$

● Coupling selection

ROTEX® GS 42

Spider 98 Shore A with clamping ring hubs 6.0 light:

Mass moments of inertia of page 136

$T_{KN} = 450 \text{ Nm}$

$J_{KA} = 0.001117 \text{ kgm}^2$

$T_{K \max} = 900 \text{ Nm}$

$J_{KL} = 0.001117 \text{ kgm}^2$

● Loading by maximum driving torque, without load torque (acceleration of spindle)

$T_{KN} \geq T_S \cdot S_t \cdot S_B$

Shock on drive side $T_S = T_{AS} \cdot M_A \cdot S_z \rightarrow = 190 \text{ Nm} \cdot 0.258 \cdot 1.0 \rightarrow T_S = 49.02 \text{ Nm}$

$M_A = \frac{J_L}{(J_A + J_L)} \rightarrow = \frac{0.110517 \text{ kgm}^2}{(0.317117 \text{ kgm}^2 + 0.110517 \text{ kgm}^2)} \rightarrow M_A = 0.258$

$J_L = J_{Mot} + J_{KL} \rightarrow 0.316 \text{ kgm}^2 + 0.001117 \text{ kgm}^2 \rightarrow J_A = 0.317117 \text{ kgm}^2$

$J_A = J_{HS} + J_{KL} \rightarrow 0.1094 \text{ kgm}^2 + 0.001117 \text{ kgm}^2 \rightarrow J_L = 0.110517 \text{ kgm}^2$

$T_{KN} \geq 49.02 \text{ Nm} \cdot 1.4 \cdot 2.4 \rightarrow T_{KN} \geq 164.7 \text{ Nm}$

T_{KN} with 450 Nm $\geq 164.7 \text{ Nm}$

● Review of shaft-hub-connection: Friction torque for clamping ring hubs type 6.0 light

The coupling has to be dimensioned such that the permissible friction torque is not exceeded during any operating condition.

$T_R \geq T_{AS}$ values T_R see page 130

Friction torque of ROTEX® GS 42 clamping ring hub 6.0 light Ø30 H7/k6 $T_R = 645 \text{ Nm} > 190 \text{ Nm}$

Result

The coupling is sufficiently dimensioned.

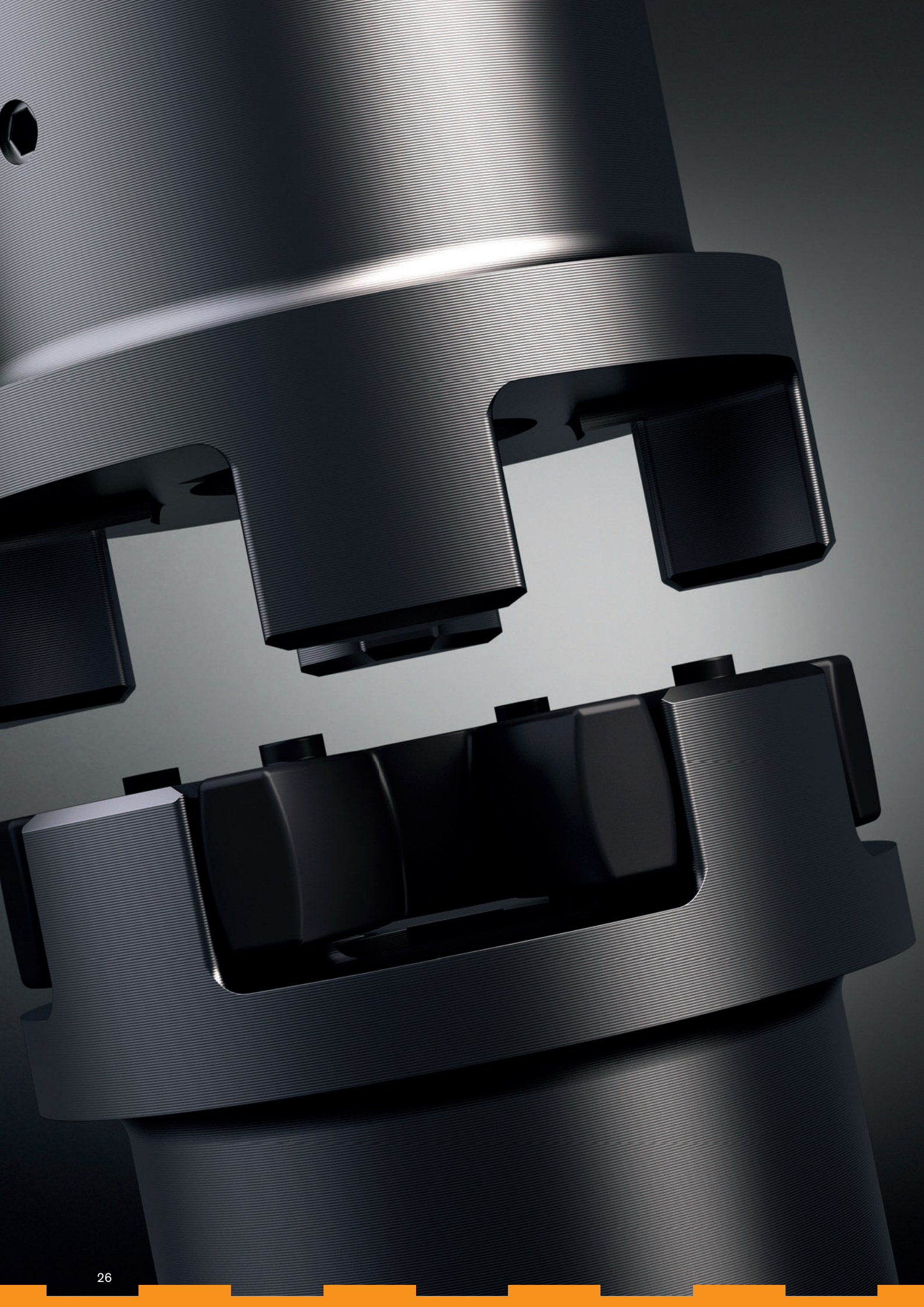

Flexible jaw and pin & bush couplings

Types and operating description 28

ROTEX®	
Types of hubs	30
Displacements	31
Standard spiders	32
Special spiders	34
Selection of standard IEC motors	35
Cylindrical bores and spline bores	36
Inch bores and taper bores	37
Standard type, material aluminium + cast + powder metal / CDP	38
Standard type, material steel / stainless steel / DIN EN 10204 / marine / UL	40
Type with taper clamping sleeve	42
Type with clamping ring hubs	43
Type with clamping hubs	44
Type with flange programme	45
Type A-H drop-out center design coupling	46
Type S-H drop-out center design coupling with SPLIT hubs	47
Type SP single-cardanic shaft coupling (Non Sparking)	48
Type SP ZS-DKM-C double-cardanic shaft coupling (Non Sparking)	49
Type ZS-DKM-H double-cardanic shaft coupling	50
Type DKM double-cardanic shaft coupling	51
Type CF, CFN, DF, DFN flange programme	52
Type ZR intermediate shaft programme	53
Type BTAN and SBAN with brake drum/ with brake disk	54
Type AFN-SB drop-out center design coupling with brake disk	56
Type SD shiftable coupling shiftable at standstill	57
Type FNN for mounting of fan	58
Other types with clamping sets	59
Other types with torque limiters	60
Weights and mass moments of inertia	61

POLY-NORM®	
Technical data	63
Selection of standard IEC motors	64
Type AR, two-part	65
Type AR for taper clamping sleeve	66
Type ADR, three-part	67
Types BTA, SBA with brake drum, brake disk	68
Type ADR-SB with brake disk for stop brake	69
Type AZR, standard drop-out center design coupling	70

POLY	
Selection of standard IEC motors	71
Type PKZ, two-part and PKD, three-part	72
Type PKA, drop-out center design coupling	73
Displacements / elastomer sets / screws	74

REVOLEX®	
Technical data	75
Type KX-D, material cast	76
Type KX-D, material steel	77
Type KX-D with brake disk	78
Type KX-D with KTR 650	80
Technical data of pins	82
Assembly / other types	83



Please note: torque increase

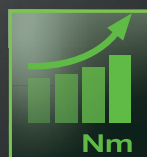

Years of experience with applications at customer sites and additional test series in the KTR test field in Rheine enabled us to determine potentials allowing for an increase of rated and maximum torques with some sizes of this series:

ROTEX®



POLY-NORM®



POLY



REVOLEX®

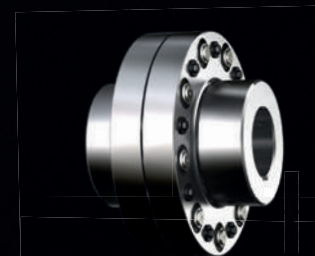

FLEXIBLE JAW AND PIN & BUSH COUPLINGS

TYPES AND OPERATING DESCRIPTION

Properties of flexible jaw and pin & bush couplings

				
Product	ROTEX®	POLY-NORM®	POLY	REVOLEX®
Type	Torsionally flexible jaw coupling			Torsionally flexible pin & bush coupling
Features				
Torsionally flexible	●	●	●	●
Damping vibrations	●	●	●	●
Maintenance-free	●	●	●	●
Axial plug-in	●	●	●	●
Shear type			●	
Fail-safe	●	●		●
Compensating for misalignment	●	●	●	●
Types				
Variant diversity	very high	average	average	high
Special features	extensive basic programme available from stock while customized solutions can be realized	basic programme available from stock	basic programme available from stock	extensive programme, ideal for customized solutions, for applications with high performances
Applications / core industries	manifold applications, applicable in all industries	pump industry, industrial gearboxes	chemical pumps, high-pressure pumps, ...	industrial gearboxes, conveyor systems, industrial fans, cableways, agitators, generators, ...
surface	allover machining, very good dynamic properties	shell surface machined	shell surface machined	allover machining, good dynamic properties
Torque range T_{KN} [Nm]				
Min.	1	40	42	4300
Max.	35,000	67,000	6,100	1,350,000
Max. circumferential speed v [m/s]				
Cast EN-GJL (dynamic balancing)	35	35	35	35
Steel + cast EN-GJL (dynamic balancing)	60			60
Hub materials available				
Steel (semi-finished product) » customized solutions available	●			●
Cast iron (GJL) » subject to mould	●	●	●	●
Nodular iron (GJS) » subject to mould	●	○		○
Aluminium wrought products (Al-H) » customized solutions available	●			
Aluminium diecast (Al-D)	●			
Stainless steel	●			
Corrosion-protected types	●	○	○	●
Spiders / elastomers				
Material	T-PUR®, PA, PEEK, Hytel, ...	NBR (up to size 180) T-PUR® (from size 200)	NBR	NR, NBR NBR electrically insulating
Degree of hardness	flexible to torsionally rigid	flexible	flexible	flexible
Temperature range in °C, min. / max. (standard)	- 50 / + 120	- 30 / + 80	- 30 / + 80	- 30 / + 80
Temperature range in °C, min. / max. (special)	- 50 / + 250	- 30 / + 80	- 30 / + 80	- 50 / + 80

● ≈ Standard
○ ≈ On request

FLEXIBLE JAW AND PIN & BUSH COUPLINGS

TYPES AND OPERATING DESCRIPTION

Product finder of jaw and pin & bush couplings

				
Product	ROTEX®	POLY-NORM®	POLY	REVOLEX®
Type	Torsionally flexible jaw coupling			Torsionally flexible pin & bush coupling
Geometries				
Design	compact	short	short	short
Mass moment of inertia	low	average	high	average
Shaft distance dimension	low / average	low	low	low
Types (extract)				
Elastomers can be radially disassembled » with no need of displacing driving/driven side	AFN, A-H, S-H, ZR, DF, DFN, CF-H	ADR, ADR-SB	PKD	standard
Intermediate shaft types » bridging larger shaft distances	ZR, ZWN	-	-	customized
Standard spacers 100 mm to 250 mm	ZS-DKM-H	AZR	PKA	customized
Shaft-to-shaft connection	standard	standard	standard	standard
Flange-to-shaft connection	CF, CFN	-	-	customized
Flange-to-flange connection » particularly short mounting length	DF, DNF	-	-	customized
Double-cardanic » compensating for big displacements, lower restoring forces	ZS-DKM-H, ZR, ZWN	-	-	-
Certifications/type examinations				
ATEX 	●	●	●	●
UL-listed 	●			
GOST R/ GOST TR 	●	●	●	●
DNV/GL 	●			●
ABS 	●			○
Bureau Veritas 	●			○
LR 	○			○
RS CLASS 	○			○
CCS 	○			○
ClassNK 	○			

● ≈ Standard
○ ≈ On request

ROTEX®

POLY-NORM®

POLY

REVOLEX®

Types of hubs

Since ROTEX® is used on many different applications and mounting situations, this coupling system is available with various hub types. These types mainly differ in that they provide either positive or frictionally engaged (backlash-free) connections, but mounting situations like, for example, gear shafts with integrated transmission cams or similar applications are covered, too.

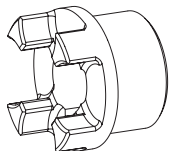

Type 1.0 hub with feather keyway and setscrew

Positive-locking power transmission, permissible torque depending on the permissible surface pressure. Not suitable for backlash-free power transmission with heavily reversing operation.

Type 1.1 hub without feather keyway, with setscrew

Non-positive torque transmission for crimping connections and adhesive bonds. (No ATEX approval)

Type 1.3 hub with spline bore (see page 36)

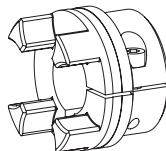

Type 2.0 clamping hub single slot without feather keyway

Frictionally engaged, backlash-free shaft-hub-connection. Transmittable torques depending on bore diameter (see page 40). (For ATEX category 3 only)

Type 2.1 clamping hub single slot with feather keyway

Positive-locking power transmission with additional friction fit. The friction fit avoids or reduces reverse backlash. Surface pressure of the keyway connection is reduced.

Type 2.3 clamping hub with spline bore (see page 36)

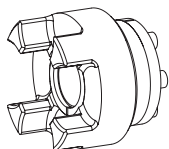

Type 4.2 hub for CLAMPEX® clamping set KTR 250

Frictionally engaged, backlash-free shaft-hub-connection for transmitting average torques.

Type 4.1 for CLAMPEX® clamping set KTR 200

Type 4.3 for CLAMPEX® clamping set KTR 400

Frictionally engaged, backlash-free shaft-hub-connection for the transmission of high torques.

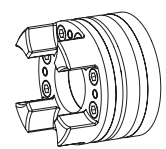

Type 6.0 clamping ring hub (see ROTEX® GS series)

Integrated frictionally engaged shaft-hub-connection for the transmission of higher torques. Screwing on elastomer side. For details about torque and dimensions see page 41. Suitable for high speeds.

Type 6.5 clamping ring hub (see ROTEX® GS series)

Design like 6.0, except for clamping screws externally. As an example for radial disassembly of intermediate pipe (special design).

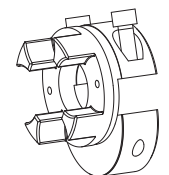

Type 7.5 clamping hub type DH without feather keyway for double-cardanic connection

Frictionally engaged, backlash-free shaft-hub-connection for radial assembly of coupling. Transmittable torques depending on bore diameter. (For ATEX category 3 only)

Type 7.6 clamping hub type DH with feather keyway for double-cardanic connection

Positive-locking power transmission with additional friction fit for radial assembly of coupling. The friction fit avoids or reduces reverse backlash. Surface pressure of the keyway connection is reduced.

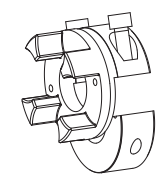

Type 7.8 clamping hub type H without feather keyway

Frictionally engaged, backlash-free shaft-hub-connection for radial assembly of coupling. Transmittable torques depending on bore diameter. (For ATEX category 3 only)

Type 7.9 clamping hub type H with feather keyway

Positive-locking power transmission with additional friction fit for radial assembly of coupling. The friction fit avoids or reduces reverse backlash. Surface pressure of the keyway connection is reduced.

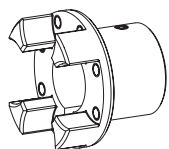

FNN hub

Coupling hub to be connected to an attachment such as brake drum, brake disk and fan.

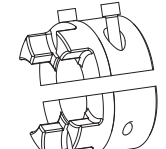

Type 7.1 SPLIT hub with feather keyway

Split hub made of cast iron. Positive-locking power transmission with additional friction fit. The friction fit avoids or reduces reverse backlash. Surface pressure of the keyway connection is reduced.

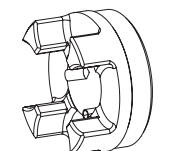

TB1 hub/TB2 hub

Coupling hub for taper clamping sleeves TB1 screwed on cam side. TB2 screwed externally.

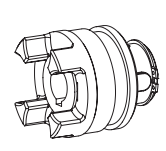

SD hub shifting hub

Coupling hub for separating or switching on the driving/driven machine with standstill of the machine. Can be combined with slip ring and shiftable linkage.

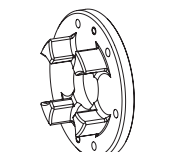

Driving flange type 3b

Driving flange to connect to customer's component. For dimensions see page 52

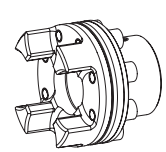

Type 3Na and 4N Driving flange with flange type K

For type AFN and BFN. With type AFN the spider can be replaced while being assembled without having to disassemble the driving and driven side.

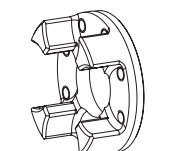

Driving flange type 3Na

Driving flange to connect to customer's component. For dimensions see page 52

Displacements

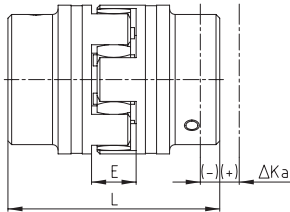
Axial displacement ΔK_a

$$L_{\max.} = L + \Delta K_a$$

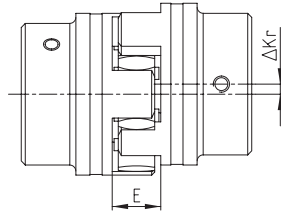
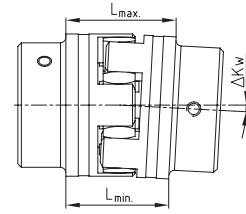
Radial displacement ΔK_r

Angular displacement ΔK_w [degree]

$$\Delta K_w \text{ [mm]} = L_{\max} - L_{\min}$$

Displacements for spider 92 and 98 Shore A

ROTEX® size	14	19	24	28	38	42	48	55	65	90	100	110	125	140	160	180	
Max. axial displacement ΔK_a [mm]	-0.5 +1.0	-0.5 +1.2	-0.5 +1.4	-0.7 +1.5	-0.7 +1.8	-1.0 +2.0	-1.0 +2.1	-1.0 +2.2	-1.0 +2.6	-1.5 +3.0	-1.5 +3.4	-1.5 +3.8	-2.0 +4.2	-2.0 +4.6	-2.0 +5.0	-2.5 +5.7	-3.0 +6.4
Max. radial displacement with $n=1500$ rpm ΔK_r [mm]	0.17	0.20	0.22	0.25	0.28	0.32	0.36	0.38	0.42	0.48	0.50	0.52	0.55	0.60	0.62	0.64	0.68
Max. angular displacement with $n=1500$ rpm ΔK_w [degree]	1.2	1.2	0.9	0.9	1.0	1.0	1.1	1.1	1.2	1.2	1.2	1.2	1.3	1.3	1.2	1.2	1.2
ΔK_w [mm]	0.67	0.82	0.85	1.05	1.35	1.70	2.00	2.30	2.70	3.30	4.30	4.80	5.60	6.50	6.60	7.60	9.00

Displacements of spider 64 Shore D

ROTEX® size	14	19	24	28	38	42	48	55	65	75	90	100	110	125	140	160	180
Max. axial displacement ΔK_a [mm]	-0.5 +1.0	-0.5 +1.2	-0.5 +1.4	-0.7 +1.5	-0.7 +1.8	-1.0 +2.0	-1.0 +2.1	-1.0 +2.2	-1.0 +2.6	-1.5 +3.0	-1.5 +3.4	-1.5 +3.8	-2.0 +4.2	-2.0 +4.6	-2.0 +5.0	-2.5 +5.7	-3.0 +6.4
Max. radial displacement with $n=1500$ rpm ΔK_r [mm]	0.11	0.13	0.15	0.18	0.21	0.23	0.25	0.27	0.30	0.34	0.36	0.37	0.40	0.43	0.45	0.46	0.49
Max. angular displacement with $n=1500$ rpm ΔK_w [degree]	1.1	1.1	0.8	0.8	0.9	0.9	1.0	1.0	1.1	1.1	1.1	1.1	1.2	1.2	1.1	1.1	1.1
ΔK_w [mm]	0.57	0.76	0.76	0.90	1.25	1.40	1.80	2.00	2.50	3.00	3.80	4.30	5.30	6.00	6.10	7.10	8.00

Displacements for spider PA, PEEK

ROTEX® size	14	19	24	28	38	42	48	55	65	75	90	100	110	125	140
Max. axial displacement ΔK_a [mm]	-0.5 +1.0	-0.5 +1.2	-0.5 +1.4	-0.7 +1.5	-0.7 +1.8	-1.0 +2.0	-1.0 +2.1	-1.0 +2.2	-1.0 +2.6	-1.5 +3.0	-1.5 +3.4	-1.5 +3.8	-2.0 +4.2	-2.0 +4.6	-2.0 +5.0
Max. radial displacement with $n=1500$ rpm ΔK_r [mm]	0.08	0.10	0.11	0.12	0.14	0.16	0.18	0.19	0.21	0.24	0.25	0.26	0.27	0.30	0.31
Max. angular displacement with $n=1500$ rpm ΔK_w [degree]	0.60	0.45	0.45	0.50	0.50	0.55	0.55	0.55	0.60	0.60	0.60	0.60	0.65	0.65	0.60
ΔK_w [mm]	0.33	0.41	0.42	0.52	0.67	0.85	1.00	1.15	1.35	1.65	2.15	2.40	2.80	3.25	3.30

The above-mentioned displacement figures of the flexible ROTEX® couplings are standard values taking into account the load of the coupling up to the rated torque T_{KN} and an operating speed $n = 1500$ rpm along with an ambient temperature of $+30^\circ\text{C}$.

The displacement figures may only be used one by one - if they appear simultaneously, they must be limited in proportion. Care should be taken to maintain the distance dimension E accurately in order to allow for axial clearance of the coupling while in operation. Detailed mounting instructions are shown on our homepage www.ktr.com.

ROTEX®

Flexible jaw couplings

Properties of standard spiders

ROTEX® 14



ROTEX® 19

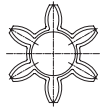

ROTEX® 24 - 65

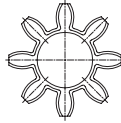

ROTEX® 75 - 160

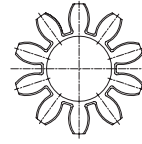



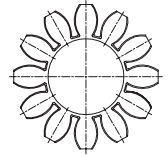

ROTEX® 180



Degree of hardness



Spider type (Shore hardness)	92 Shore A (T-PUR®)	92 Shore A
	 T-PUR®	
Size	14 to 180	14 to 90
Material	T-PUR®	Polyurethane (PUR)
Permissible temperature range		
Permanent temperature	-50 °C to +120 °C	-40 °C to +90 °C
Short-term temperature	-50 °C to +150 °C	-50 °C to +120 °C
Features	<ul style="list-style-type: none"> - significantly higher service life expectancy - very good temperature resistance - improved damping of vibrations - good damping, average flexibility - suitable for all hub materials 	<ul style="list-style-type: none"> - good damping, average flexibility - suitable for all hub materials

Spider type (Shore hardness)	98 Shore A (T-PUR®) ¹⁾	98 Shore A ¹⁾
	 T-PUR®	
Size	14 to 180	14 to 90
Material	T-PUR®	Polyurethane (PUR)
Permissible temperature range		
Permanent temperature	-50 °C to +120 °C	-30 °C to +90 °C
Short-term temperature	-50 °C to +150 °C	-40 °C to +120 °C
Features	<ul style="list-style-type: none"> - significantly higher service life expectancy - very good temperature resistance - improved damping of vibrations - transmission of high torques with average damping - recommended hub material: steel, GJL and GJS 	<ul style="list-style-type: none"> - transmission of high torques with average damping - recommended hub material: steel, GJL and GJS

Spider type (Shore hardness)	64 Shore D (T-PUR®)
	 T-PUR®
Size	14 to 180
Material	T-PUR®
Permissible temperature range	
Permanent temperature	-50 °C to +120 °C
Short-term temperature	-50 °C to +150 °C
Features	<ul style="list-style-type: none"> - significantly higher service life expectancy - very good temperature resistance - improved damping of vibrations - transmission of very high torques with low damping - recommended hub material: steel and GJS

Technical data of standard spiders

92 Shore A spider made of T-PUR® and PUR															
ROTEX® size	Max. speed		Torsion angle ϕ with		Torque [Nm]				Damping power P _{KW} [W] ³⁾	Relative damping ψ	Resonance factor V _R	Torsion spring stiffness C dyn. [Nm/rad]			
	v=35 m/s cast material	v=40 m/s steel	T _{KN}	T _{K max}	DIN 740 ¹⁾			T _{K max} ²⁾				1.0 T _{KN}	0.75 T _{KN}	0.5 T _{KN}	0.25 T _{KN}
					Rated T _{KN}	Max. T _{K max}	Vibratory T _{KW}								
14	22200	25400	6.4°	10°	7.5	15	2.0	22.5	—			0.38x10 ³	0.31x10 ³	0.24x10 ³	0.14x10 ³
19	16700	19000			10	20	2.6	30	4.8			1.28x10 ³	1.05x10 ³	0.8x10 ³	0.47x10 ³
24	12100	13800			35	70	9.1	105	6.6			4.86x10 ³	3.98x10 ³	3.01x10 ³	1.79x10 ³
28	10100	11500			95	190	25	285	8.4			10.9x10 ³	8.94x10 ³	6.76x10 ³	4.01x10 ³
38	8300	9500			190	380	49	570	10.2			21.05x10 ³	17.26x10 ³	13.05x10 ³	7.74x10 ³
42	7000	8000			265	530	69	795	12.0			23.74x10 ³	19.47x10 ³	14.72x10 ³	8.73x10 ³
48	6350	7250			310	620	81	930	13.8			36.7x10 ³	30.09x10 ³	22.75x10 ³	13.49x10 ³
55	5550	6350			410	820	107	1230	15.6			50.7x10 ³	41.59x10 ³	31.45x10 ³	18.64x10 ³
65	4950	5650	3.2°	5°	625	1250	163	1875	18.0	0.80	7.90	97.1x10 ³	79.65x10 ³	60.2x10 ³	35.7x10 ³
75	4150	4750			1280	2560	333	3840	21.6			113.3x10 ³	92.9x10 ³	70.3x10 ³	41.65x10 ³
90	3300	3800			2400	4800	624	7200	30.0			190.1x10 ³	155.9x10 ³	117.9x10 ³	69.9x10 ³
100	2950	3350			3300	6600	858	9900	36.0			253.1x10 ³	207.5x10 ³	156.9x10 ³	93x10 ³
110	2600	2950			4800	9600	1248	14400	42.0			415.5x10 ³	336.9x10 ³	257.6x10 ³	177.4x10 ³
125	2300	2600			6650	13300	1729	19950	48.0			647.7x10 ³	537.3x10 ³	412.2x10 ³	277.5x10 ³
140	2050	2350			8550	17100	2223	25650	54.6			813.4x10 ³	670.2x10 ³	519.7x10 ³	351.7x10 ³
160	1800	2050			12800	25600	3328	38400	75.0			1298x10 ³	1104x10 ³	901.9x10 ³	655.7x10 ³
180	1550	1800			18650	37300	4849	55950	78.0			2327x10 ³	1981x10 ³	1618x10 ³	1176x10 ³

98 Shore A spider made of T-PUR® and PUR															
ROTEX® size	Max. speed		Torsion angle ϕ with		Torque [Nm]				Damping power P _{KW} [W] ³⁾	Relative damping ψ	Resonance factor V _R	Torsion spring stiffness C dyn. [Nm/rad]			
	v=35 m/s cast material	v=40 m/s steel	T _{KN}	T _{K max}	DIN 740 ¹⁾			T _{K max} ²⁾				1.0 T _{KN}	0.75 T _{KN}	0.5 T _{KN}	0.25 T _{KN}
					Rated T _{KN}	Max. T _{K max}	Vibratory T _{KW}								
14	22200	25400	6.4°	10°	12.5	25	3.3	37.5	—			0.56x10 ³	0.46x10 ³	0.35x10 ³	0.21x10 ³
19	16700	19000			17	34	4.4	51	4.8			2.92x10 ³	2.39x10 ³	1.81x10 ³	1.07x10 ³
24	12100	13800			60	120	16	180	6.6			9.93x10 ³	8.14x10 ³	6.16x10 ³	3.65x10 ³
28	10100	11500			160	320	42	480	8.4			26.77x10 ³	21.95x10 ³	16.6x10 ³	9.84x10 ³
38	8300	9500			325	650	85	975	10.2			48.57x10 ³	39.83x10 ³	30.11x10 ³	17.85x10 ³
42	7000	8000			450	900	117	1350	12.0			54.5x10 ³	44.69x10 ³	33.79x10 ³	20.03x10 ³
48	6350	7250			525	1050	137	1575	13.8			65.3x10 ³	53.54x10 ³	40.48x10 ³	24x10 ³
55	5550	6350			685	1370	178	2055	15.6			95x10 ³	77.9x10 ³	58.88x10 ³	34.9x10 ³
65	4950	5650	3.2°	5°	940	1880	244	2820	18.0	0.80	7.90	129.5x10 ³	106.2x10 ³	80.3x10 ³	47.6x10 ³
75	4150	4750			1920	3840	499	5760	21.6			197.5x10 ³	162x10 ³	122.5x10 ³	72.6x10 ³
90	3300	3800			3600	7200	936	10800	30.0			312.2x10 ³	256x10 ³	193.6x10 ³	114.7x10 ³
100	2950	3350			4950	9900	1287	14850	36.0			383.3x10 ³	314.3x10 ³	237.6x10 ³	140.9x10 ³
110	2600	2950			7200	14400	1872	21600	42.0			805.9x10 ³	663.1x10 ³	515.3x10 ³	360.5x10 ³
125	2300	2600			10000	20000	2600	30000	48.0			1207x10 ³	1003x10 ³	773.1x10 ³	552.5x10 ³
140	2050	2350			12800	25600	3328	38400	54.6			1549x10 ³	1283x10 ³	979.8x10 ³	674.1x10 ³
160	1800	2050			19200	38400	4992	57600	75.0			2481x10 ³	2137x10 ³	1781x10 ³	1275x10 ³
180	1550	1800			28000	56000	7280	84000	78.0			4220x10 ³	3635x10 ³	3031x10 ³	2170x10 ³

64 Shore D spider made of T-PUR® and PUR															
ROTEX® size	Max. speed		Torsion angle ϕ with		Torque [Nm]				Damping power P _{KW} [W] ³⁾	Relative damping ψ	Resonance factor V _R	Torsion spring stiffness C dyn. [Nm/rad]			
	v=35 m/s cast material	v=40 m/s steel	T _{KN}	T _{K max}	DIN 740 ¹⁾			T _{K max} ²⁾				1.0 T _{KN}	0.75 T _{KN}	0.5 T _{KN}	0.25 T _{KN}
					Rated T _{KN}	Max. T _{K max}	Vibratory T _{KW}								
14	22200	25400	4.5°	7.0°	16	32	4.2	48	9.0			0.76x10 ³	0.62x10 ³	0.47x10 ³	0.28x10 ³
19	16700	19000			21	42	5.5	63	7.2			5.35x10 ³	4.39x10 ³	3.32x10 ³	1.97x10 ³
24	12100	13800			75	150	19.5	225	9.9			15.11x10 ³	12.39x10 ³	9.37x10 ³	5.55x10 ³
28	10100	11500			200	400	52	600	12.6			27.52x10 ³	22.57x10 ³	17.06x10 ³	10.12x10 ³
38	8300	9500			405	810	105	1215	15.3			70.15x10 ³	57.52x10 ³	43.49x10 ³	25.78x10 ³
42	7000	8000			560	1120	146	1680	18.0			79.9x10 ³	65.5x10 ³	49.52x10 ³	29.35x10 ³
48	6350	7250			655	1310	170	1965	20.7			95.5x10 ³	78.3x10 ³	59.22x10 ³	35.1x10 ³
55	5550	6350			825	1650	215	2475	23.4			107.9x10 ³	88.5x10 ³	66.9x10 ³	39.66x10 ³
65	4950	5650	2.5°	3.6°	1175	2350	306	3525	27.0	0.75	8.50	151.1x10 ³	123.9x10 ³	93.7x10 ³	55.53x10 ³
75	4150	4750			2400	4800	624	7200	32.4			248.2x10 ³	203.5x10 ³	153.9x10 ³	91.2x10 ³
90	3300	3800			4500	9000	1170	13500	45.0			674.5x10 ³	553.1x10 ³	418.2x10 ³	247.9x10 ³
100	2950	3350			6185	12370	1608	18555	54.0			861.2x10 ³	706.2x10 ³	533.9x10 ³	316.5x10 ³
110	2600	2950			9000	18000	2340	27000	63.0			1230x10 ³	1001x10 ³	773.1x10 ³	531.4x10 ³
125	2300	2600			12500	25000	3250	37500	72.0			1749x10 ³	1436x10 ³	1149x10 ³	832.1x10 ³
140	2050	2350			16000	32000	4160	48000	81.9			2312x10 ³	1929x10 ³	1521x10 ³	1082x10 ³
160	1800	2050			24000	48000	6240	72000	112.5			3415x10 ³	2961x10 ³	2471x10 ³	1830x10 ³
180	1550	1800			35000	70000	9100	105000	117.0			5670x10 ³	4917x10 ³	4103x10 ³	3038x10 ³

¹⁾ see catalogue page 15
²⁾ ≤ 1000 load cycles
³⁾ with +30°C



Temperature factor S _t											
	-50 °C	-30 °C +30 °C	+40 °C	+50 °C	+60 °C	+70 °C	+80 °C	+90 °C	+100 °C	+110 °C	+120 °C
T-PUR®	1.0	1.0	1.1	1.2	1.3	1.45	1.6	1.8	2.1	2.5	3.0
PUR	—	1.0	1.2	1.3	1.4	1.55	1.8	2.2	—	—	—

Unless explicitly specified in your order, we will supply spiders with Shore hardness 92 Shore A T-PUR®.
 For circumferential speeds exceeding v = 30 m/s dynamic balancing is required. For circumferential speeds exceeding v = 35 m/s only steel or nodular iron.

ROTEX®

Flexible jaw couplings

Technical data and properties of special spiders

		
Designation	PA	PEEK
Material	Polyamide	Polyetheretherketone
Permissible temperature range		
Permanent temperature	-20 °C to +130 °C ¹⁾	up to +180 °C (ATEX up to +160 °C)
Short-term temperature	-30 °C to +150 °C ¹⁾	up to +250 °C
Features	<ul style="list-style-type: none"> - small twisting angle and high torsion spring stiffness - transmission of very high torques with very low damping - good resistance to chemicals ¹⁾ - recommended hub material: steel - high restoring forces with displacements 	<ul style="list-style-type: none"> - small twisting angle and high torsion spring stiffness - transmission of very high torques with very low damping - highly temperature-resistant, resistant to hydrolysis - good resistance to chemicals - recommended hub material: steel - high restoring forces with displacements

¹⁾ different properties depending on compound

Torques			
ROTEX® size	PA, PEEK		
	T _{KN} [Nm]	T _{K max} [Nm]	T _{KW} [Nm]
14	22	44	5.5
19	30	60	8.0
24	105	210	27.5
28	280	560	73
38	565	1130	147
42	785	1570	204
48	915	1830	238
55	1200	2400	312
65	1645	3290	427
75	2560	5130	667
90	6300	12600	1640
100	8650	17300	2250
110	10500	21000	2730
125	13000	26000	3380

Temperature factor S _t												
	-50 °C	-30 °C +30 °C	+40 °C	+50 °C	+60 °C	+70 °C	+80 °C	+90 °C	+100 °C	+110 °C	+120 °C	+180 °C
PA	-	1.0	1.15	1.25	1.4	1.6	1.9	2.3	3.0	-	-	-
PEEK	-	1.0	1.0	1.0	1.0	1.0	1.0	1.0	1.0	1.0	1.0	1.0

Installation of spider

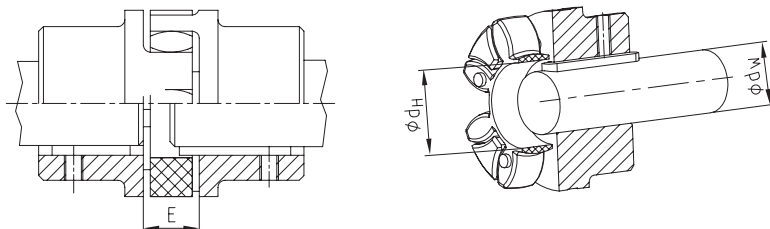

Shaft ϕd_{WY} with feather key (acc. to DIN 6885 sheet 1) protruding into the spider ϕd_H

Assembly dimensions																	
ROTEX® size	14	19	24	28	38	42	48	55	65	75	90	100	110	125	140	160	180
Distance dimension E	13	16	18	20	24	26	28	30	35	40	45	50	55	60	65	75	85
Dimension d _H	10	18	27	30	38	46	51	60	68	80	100	113	127	147	165	190	220
Dimension d _{WY} ²⁾	7	12	20	22	28	36	40	48	55	65	80	95	100	120	135	160	185

²⁾ If the shaft diameter is smaller than or equal to dimension d_H, one shaft end or both shaft ends may protrude with the feather keyway into the spider.

Selection of standard IEC motors

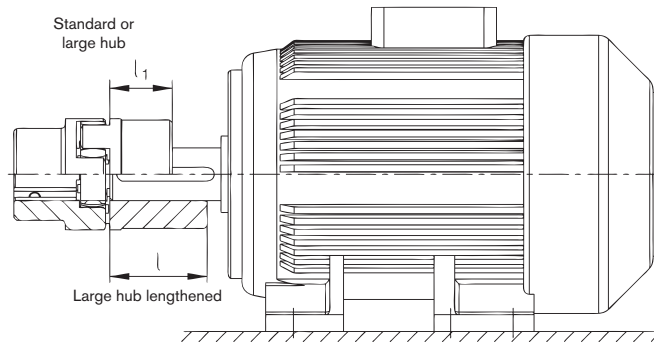

ROTEX® couplings for standard IEC motors, protection class IP 54/IP 55 (spider 92 Shore A)

A. C. motor 50 Hz		Motor power n= 3000 rpm 2 poles		ROTEX® coupling size	Motor power n= 1500 rpm 4 poles		ROTEX® coupling size	Motor power n= 1000 rpm 6 poles		ROTEX® coupling size	Motor power n= 750 rpm 8 poles		ROTEX® coupling size
Size	Shaft end dxt [mm]		Power P [kW]		Torque T [Nm]	Power P [kW]		Torque T [Nm]	Power P [kW]		Torque T [Nm]	Power P [kW]	
	2 poles	4, 6, 8 poles											
56	9 x 20		0.09	0.32	9 ¹⁾	0.06	0.43	9 ¹⁾	0.037	0.43	9 ¹⁾		
			0.12	0.41		0.09	0.64		0.045	0.52			
63	11 x 23		0.18	0.62	14	0.12	0.88	14	0.06	0.7	14		
			0.25	0.86		0.18	1.3		0.09	1.1			
71	14 x 30		0.37	1.3	14	0.25	1.8	14	0.18	2	14	0.09	1.4
			0.55	1.9		0.37	2.5		0.25	2.8		0.12	1.8
80	19 x 40		0.75	2.5	19	0.55	3.7	19	0.37	3.9	19	0.18	2.5
			1.1	3.7		0.75	5.1		0.55	5.8		0.25	3.5
90S	24 x 50		1.5	5	19	1.1	7.5	19	0.75	8	19	0.37	5.3
90L			2.2	7.4		1.5	10		1.1	12		0.55	7.9
100L	28 x 60		3	9.8	24	2.2	15	24	1.5	15	24	0.75	11
						3	20		2.2	22		1.1	16
112M			4	13	24	4	27	24	2.2	22	24	1.5	21
132S			5.5	18		5.5	36		3	30		2.2	30
132M	38 x 80		7.5	25	28	7.5	49	28	4	40	28	3	40
									5.5	55			
160M	42 x 110		11	36	38	11	72	38	7.5	75	38	4	54
			15	49		15	98		11	109		5.5	74
160L			18.5	60	38	18.5	121	38	15	148	38	11	145
180M	48 x 110		22	71		22	144		15	148		11	145
180L					42	30	196	42	18.5	181	42	15	198
200L	55 x 110		30	97		30	196		22	215		15	198
225S	55 x 110				48	37	240	48			48	18.5	244
225M	60 x 140	60 x 140	45	145		45	292		30	293		22	290
250M	60 x 140	65 x 140	55	177	48	55	356	55	37	361	55	30	392
280S			75	241		75	484		45	438		37	483
280M	75 x 140		90	289	55	90	581	55	55	535	55	45	587
315S			110	353		110	707		75	727		55	712
315M	80 x 170		132	423	65	132	849	75	90	873	75	75	971
			160	513		160	1030		110	1070		90	1170
315L	65 x 140		200	641	75	200	1290	90	132	1280	90	110	1420
										160		1550	132
315	85 x 170		250	802	75	250	1600	90	200	1930	90	160	2070
			315	1010		315	2020		250	2410		200	2580
355	75 x 140		355	1140	90	355	2280	100			110		
			400	1280		400	2570		315	3040		250	3220
			500	1600	100	500	3210	110	400	3850	125	315	4060
			560	1790		560	3580		450	4330		355	4570
400	80 x 170		630	2020	100	630	4030	125	500	4810	140	400	5150
			710	2270		710	4540		560	5390		450	5790
			800	2560	110	800	5120	140	630	6060	160	500	6420
450	90 x 170		900	2880		900	5760		710	6830		560	7190
			1000	3200	1000	6400	800	7690	630	8090			

The coupling selection is based on an ambient temperature up to +30 °C. The selection is based on a minimum safety factor of 2 versus the max. coupling torque ($T_{K \max}$). A detailed selection is possible according to catalogue, page 14 et seqq. Drives with periodical torque curves must be selected according to DIN 740 part 2. If requested, KTR will perform the selection. Torque T = rated torque according to Siemens catalogue M 11 · 1994/95.

¹⁾ For dimensions see ROTEX® GS series

²⁾ For motor hub made of steel see page 40

Cylindrical bores and spline bores

ROTEX® size		Stock programme of cylindrical finish bores [mm] H7 feather keyway acc. to DIN 6885 sheet 1 [JS9] and thread for setscrews																																				
Material	Un-bored	Ø6	Ø8	Ø9	Ø10	Ø11	Ø12	Ø14	Ø15	Ø16	Ø17	Ø18	Ø19	Ø20	Ø22	Ø24	Ø25	Ø26	Ø30	Ø32	Ø35	Ø38	Ø40	Ø42	Ø45	Ø48	Ø50	Ø55	Ø60	Ø65	Ø70	Ø75	Ø80	Ø85	Ø90	Ø100		
14	Sint	●																																				
	Al-H	●	●	●	●	●	●	●	●	●																												
19	Sint	●																																				
	Al-D	●	●	●	●	●	●	●	●	●	●	●	●	●	●	●	●	●	●	●	●	●	●	●	●	●	●	●	●	●	●	●	●	●	●	●	●	●
	St	●	●	●	●	●	●	●	●	●	●	●	●	●	●	●	●	●	●	●	●	●	●	●	●	●	●	●	●	●	●	●	●	●	●	●	●	●
24	Sint	●																																				
	Al-D	●			●	●	●	●	●	●	●	●	●	●	●	●	●	●	●	●	●	●	●	●	●	●	●	●	●	●	●	●	●	●	●	●	●	●
	St	●			●	●	●	●	●	●	●	●	●	●	●	●	●	●	●	●	●	●	●	●	●	●	●	●	●	●	●	●	●	●	●	●	●	●
28	Al-D	●																																				
	St	●																																				
38	GJL	●																																				
	St	●																																				
42	GJL	●																																				
	St	●																																				
48	GJL	●																																				
	St	●																																				
55	GJL	●																																				
	St	●																																				
65	GJL	●																																				
	St	●																																				
75	GJL	●																																				
	St	●																																				
90	GJL	●																																				
	St	●																																				

Basic programme of SAE involute spline												
Spline code	Size	Pitch circle	Pitch	No. of teeth	Angle	Spline code	Size	Pitch circle	Pitch	No. of teeth	Angle	
PH-S	5/8"	14.28	16/32	9	30°	PS-S	1 1/2"	35.98	12/24	17	30°	
PI-S	3/4"	17.46	16/32	11	30°	PD-S	1 1/2"	36.51	16/32	23	30°	
PB-S	7/8"	20.63	16/32	13	30°	PE-S	1 3/4"	42.86	16/32	27	30°	
PB-BS	1"	23.81	16/32	15	30°	PK-S	1 3/4"	41.275	8/16	13	30°	
PJ	1 1/8"	26.98	16/32	17	30°	PT-C ¹⁾	2"	47.625	8/16	15	30°	
PC-S	1 1/4"	29.63	12/24	14	30°	PQ-C ¹⁾	2 1/4"	53.975	8/16	17	30°	
PA-S	1 3/8"	33.33	16/32	21	30°							

Basic programme of spline bores acc. to DIN 5482										
Size	Pitch circle	Module	No. of teeth	Profile correction	Size	Pitch circle	Module	No. of teeth	Profile correction	
A 17 x 14	14.40	1.6	9	+0.600 ²⁾	A 35 x 31	31.50	1.75	18	+0.676	
A 20 x 17	19.20	1.6	12	-0.2	A 40 x 36	38.00	1.9	20	+0.049	
A 25 x 22	22.40	1.6	14	+0.550	A 45 x 41	44.00	2	22	+0.181	
A 28 x 25	26.25	1.75	15	+0.302	A 50 x 45	48.00	2	24	+0.181	
A 30 x 27	28.00	1.75	16	+0.327						

Basic programme of spline bores acc. to DIN 5480								
Spline code	Pitch circle	Module	No. of teeth	Spline code	Pitch circle	Module	No. of teeth	
20 x 1 x 18 x 7H	18.0	1	18	40 x 2 x 18 x 8H	36.0	2	18	
20 x 1.25 x 14 x 7H	17.5	1.25	14	45 x 2 x 21 x 7H	41.0	2	21	
25 x 1.25 x 18 x 7H	22.5	1.25	18	48 x 2 x 22 x 9H	44.0	2	22	
28 x 1.25 x 21 x 7H	26.25	1.25	21	50 x 2 x 24 x 8H	48.0	2	24	
30 x 2 x 14 x 7H	26.0	2	14	60 x 2 x 28 x 8H	56.0	2	28	
32 x 2 x 14 x 8H	28.0	2	14	75 x 3 x 24 x 7H	72.0	3	24	
35 x 2 x 16 x 8H	32.0	2	16	80 x 3 x 25 x 8H	75.0	3	25	

Basic programme of spline bores acc. to DIN 9611 - ISO 500 (p.t.o. shaft connection)				
Size	Width of keyway	No. of teeth	Tip circle	Root circle
1 3/8"	8.69	6	34.93	29.65
1 3/8"	-	21	34.95	34.80 ³⁾
1 3/4"	11.07	6	44.45	37.74
1 3/4"	-	20	45.20	40.20

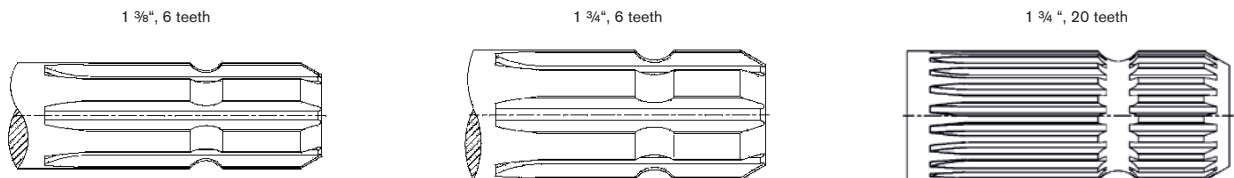

Spline clamping hubs are often adapted to the shafts of hydraulic pumps/hydraulic motor shafts. Please contact us for the respective hub length of the spline code!

¹⁾ For clamping hubs only, with plug-in hubs use code PT or PQ.

²⁾ Profile correction different from DIN

³⁾ Similar to code PA-S

Inch bores and taper bores

Stock programme of inch bores						Size										
Bore and keyway acc. to ANSI/AGMA 9002-C14 Bore (clearance fit) Keyway (commercial class fit)						19	24	28	38	42	48	55	65	75	90	
KTR code	Ø bore ["]	Width of keyway ["]	Ø bore [mm]	Width of keyway [mm]	Keyway depth/ Tolerance +0.381 [mm]	Steel				Cast iron (GJL)						
Tb	3/8	1/8	9.525 +0.0254	3.175 +0.051	10.972											
DNB	7/16	3/32	11.112 +0.0254	2.382 +0.051	12.293											
T	1/2	3/16	12.7 +0.0254	4.762 +0.051	14.757											
Ta	1/2	1/8	12.7 +0.0254	3.175 +0.051	14.224	●	●									
DNC	17/32	1/8	13.495 +0.0254	3.175 +0.051	15.011											
Do	9/16	1/8	14.287 +0.0254	3.175 +0.051	15.824											
E	5/8	1/8	15.875 +0.0254	3.175 +0.051	17.424											
Es	5/8	5/32	15.875 +0.0254	3.968 +0.051	17.729	●	●	●								
Ed	5/8	3/16	15.875 +0.0254	4.762 +0.051	18.008	●	●									
DNH	11/16	3/16	17.462 +0.0254	4.762 +0.051	19.634											
Ad	3/4	1/8	19.05 +0.0254	3.175 +0.051	20.624											
A	3/4	3/16	19.05 +0.0254	4.762 +0.051	21.259	●	●	●	●							
G	7/8	3/16	22.225 +0.0254	4.762 +0.051	24.485	●	●	●	●	●						
F	7/8	1/4	22.225 +0.0254	6.35 +0.051	25.069		●	●	●	●						
Gf	15/16	1/4	23.812 +0.0254	6.35 +0.051	26.695											
H	1	3/16	25.4 +0.0254	4.762 +0.051	27.686											
Hs	1	1/4	25.4 +0.0254	6.35 +0.051	28.295		●	●	●	●						
R	1 1/16	3/16	26.987 +0.0254	4.762 +0.051	29.286											
Sb	1 1/8	1/4	28.575 +0.0254	6.35 +0.051	31.521		●	●	●	●						
Sd	1 1/8	5/16	28.575 +0.0254	7.937 +0.051	32.105											
Js	1 1/4	1/4	31.75 +0.0254	6.35 +0.051	34.721				●							
K	1 1/4	5/16	31.75 +0.0254	7.937 +0.051	35.331			●	●	●	●	●				
Ma	1 3/8	5/16	34.925 +0.0254	7.937 +0.051	38.557			●	●							
RH1	1 3/8	3/8	34.925 +0.0254	9.525 +0.063	39.141											
Cb	1 7/16	3/8	36.512 +0.0254	9.525 +0.063	40.767											
Ca	1 1/2	5/16	38.1 +0.0254	7.937 +0.051	41.783											
C	1 1/2	3/8	38.1 +0.0254	9.525 +0.0635	42.392				●	●	●	●	●	●		
Nb	1 5/8	3/8	41.275 +0.0254	9.525 +0.0635	45.618				●	●						
Ls	1 3/4	3/8	44.45 +0.0254	9.525 +0.0635	48.818											
L	1 3/4	7/16	44.45 +0.0254	11.112 +0.0635	49.428											
Lu	1 7/8	1/2	47.625 +0.0254	12.7 +0.0635	53.238					●						
Da	1 15/16	1/2	49.212 +0.0254	12.7 +0.0635	54.864											
Ds	2	1/2	50.8 +0.0254	12.7 +0.0635	56.464											
Pa	2 1/8	1/2	53.975 +0.0381	12.7 +0.063	59.69											
U	2 1/4	1/2	57.15 +0.0381	12.7 +0.063	62.915											
Ub	2 3/8	5/8	60.325 +0.0381	15.875 +0.076	67.335											
Wd	3 3/8	7/8	85.725 +0.0381	22.225 +0.076	95.504											
Wf	3 5/8	7/8	92.075 +0.0381	22.225 +0.076	101.955											

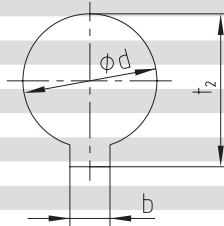

Basic programme taper 1:3					
Code	d ^{+0.05}	(d ₂)	b ^{JS9}	t ₂ ^{+0.1}	l _K
N/1	9.7	7.575	2.4 ^{+0.05}	10.85	17.0
N/1c	11.6	9.5375	3 ^{JS9}	12.90	16.5
N/1e	13.0	10.375	2.4 ^{+0.05}	13.80	21.0
N/1d	14.0	11.813	3 ^{JS9}	15.50	17.5
N/1b	14.3	11.8625	3.2 ^{+0.05}	15.65	19.5
N/2	17.287	14.287	3.2 ^{+0.05}	18.24	24.0
N/2a	17.287	14.287	4 ^{JS9}	18.94	24.0
N/2b	17.287	14.287	3 ^{JS9}	18.34	24.0
N/3	22.002	18.502	4 ^{JS9}	23.40	28.0
N/4	25.463	20.963	4.78 ^{+0.05}	27.83	36.0
N/4b	25.463	20.963	5 ^{JS9}	28.23	36.0
N/4a	27.0	22.9375	4.78 ^{+0.05}	28.80	32.5
N/4g	28.45	23.6375	6 ^{JS9}	29.32	38.5
N/5	33.176	27.676	6.38 ^{+0.05}	35.39	44.0
N/5a	33.176	27.676	7 ^{JS9}	35.39	44.0

With code N/6 and N/6a keyway in parallel with taper.

Basic programme taper 1:10					
Code	d ^{+0.05}	(d ₂)	b ^{JS9}	t ₂ ^{+0.1}	l _K
CX	19.95	16.75	5 ^{JS9}	22.08	32
DX	24.95	20.45	6 ^{JS9}	26.68	45
EX	29.75	24.75	8 ^{JS9}	31.88	50

Basic programme taper 1:5					
Code	d ^{+0.05}	(d ₂)	b ^{JS9}	t ₂ ^{+0.1}	l _K
A-10	9.85	7.55	2 ^{JS9}	1.0	11.5
B-17	16.85	13.15	3 ^{JS9}	1.8	18.5
C-20	19.85	15.55	4 ^{JS9}	2.2	21.5
Cs-22	21.95	17.65	3 ^{JS9}	1.8	21.5
D-25	24.85	19.55	5 ^{JS9}	2.9	26.5
E-30	29.85	23.55	6 ^{JS9}	2.6	31.5
F-35	34.85	27.55	6 ^{JS9}	2.6	36.5
G-40	39.85	32.85	6 ^{JS9}	2.6	35.0

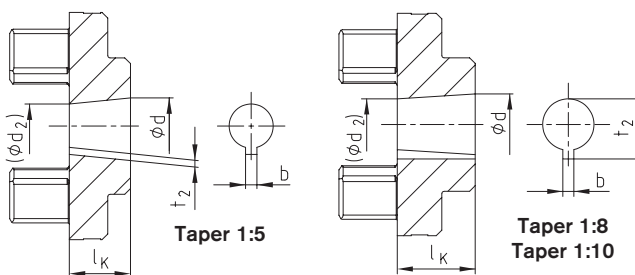

ROTEX® Standard Flexible jaw couplings

Material aluminium + cast + powder metal

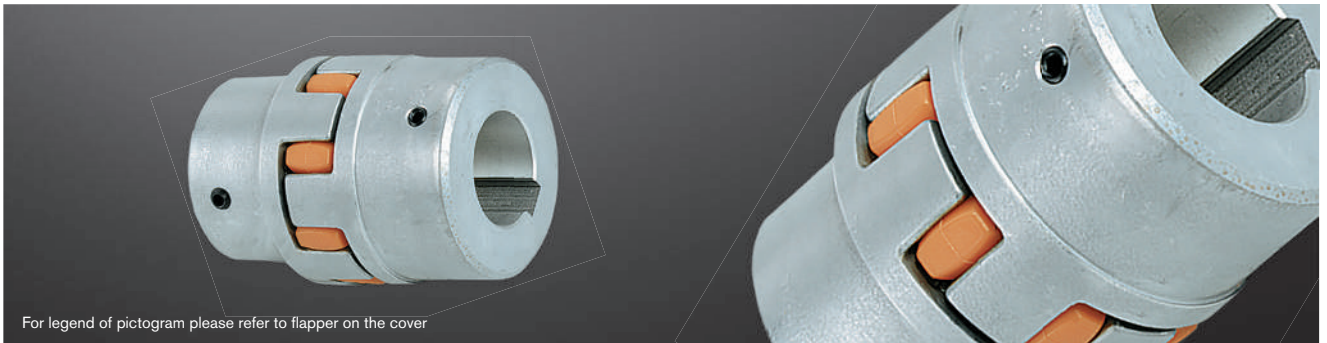

For legend of pictogram please refer to flapper on the cover

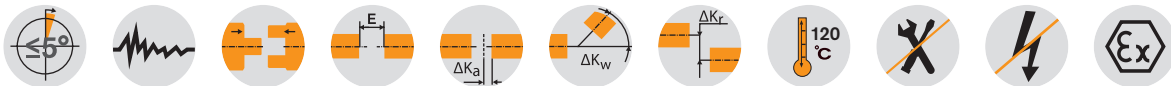

ROTEX® Powder metal steel (Sint)																			
Size	Component	Spider ¹⁾ (component 2) Rated torque [Nm]			Finish bore d	Dimensions [mm]													
		92 ShA	98 ShA	64 ShD		General													
					L	l ₁ , l ₂	E	b	s	D _H	d _H	D	N	G	t	T _A [Nm]			
14	1a	7.5	12.5	16	0-16	35	11	13	10	1.5	30	10	30	-	M4	5	1.5		
19	1a	10	17	21	0-24	66	25	16	12	2.0	40	18	40	-	M5	10	2		
24	1a	35	60	75	0-28	78	30	18	14	2.0	56	27	40	-	M5	10	2		

ROTEX® Aluminium diecast (Al-D)																			
Size	Component	Spider ¹⁾ (component 2) Rated torque [Nm]			Finish bore d	Dimensions [mm]													
		92 ShA	98 ShA	64 ShD		General													
					L	l ₁ , l ₂	E	b	s	D _H	d _H	D	N	G	t	T _A [Nm]			
19	1	10	17	-	6-19	66	25	16	12	2	41	18	32	20	M5	10	2		
	19-24				41														
24	1	35	60	-	9-24	78	30	18	14	2	56	27	40	24	M5	10	2		
	22-28				56														
28	1	95	160	-	10-28	90	35	20	15	2.5	66	30	48	28	M8	15	10		
	28-38				66														

ROTEX® Aluminium (Al-H)																			
Size	Component	Spider ¹⁾ (component 2) Rated torque [Nm]			Finish bore d	Dimensions [mm]													
		92 ShA	98 ShA	64 ShD		General													
					L	l ₁ , l ₂	E	b	s	D _H	d _H	D	N	G	t	T _A [Nm]			
5	1a	0.5	0.9	-	0-6	15	5	5	4	0.5	10	-	-	-	M2	2.5	-		
7	1a	1.2	2.0	2.4	0-7	22	7	8	6	1.0	14	-	-	-	M3	3.5	-		
9	1a	3.0	5.0	6.0	0-11	30	10	10	8	1.0	20	7.2	-	-	M4	5	1.5		
12	1a	5.0	9.0	12	0-12	34	11	12	10	1.0	25	8.5	-	-	M4	5	1.5		
14	1a	7.5	12.5	16	0-16	35	11	13	10	1.5	30	10.5	-	-	M4	5	1.5		
19	1a	10	17	26	0-24	66	25	16	12	2.0	40	18	-	-	M5	10	2		
24	1a	35	60	75	0-28	78	30	18	14	2.0	55	27	-	-	M5	10	2		
28	1a	95	160	200	0-38	90	35	20	15	2.5	65	30	-	-	M8	15	10		
38	1a	190	325	405	0-45	114	45	24	18	3.0	80	38	-	-	M8	15	10		
42	1a	265	450	560	0-55	126	50	26	20	3.0	95	46	-	-	M8	20	10		
48	1a	310	525	655	0-62	140	56	28	21	3.0	105	51	-	-	M8	20	10		

The coupling is provided with a ROTEX® GS spider as a standard (ROTEX® standard spider available, if requested).

ROTEX® Cast iron (GJL)																			
Size	Component	Spider ¹⁾ (component 2) Rated torque [Nm]			Finish bore d	Dimensions [mm]													
		92 ShA	98 ShA	64 ShD		General													
					L	l ₁ , l ₂	E	b	s	D _H	d _H	D	N	G	t	T _A [Nm]			
38	1a	190	325	405	12-40	114	45	24	18	3	80	38	66	37	M8	15	10		
	38-48				78														
42	1b	265	450	560	12-48	126	50	26	20	3	95	46	75	40	M8	20	10		
	14-45				94														
48	1b	310	525	655	14-55	176	75	28	21	3.5	105	51	85	45	M8	20	10		
	15-52				104														
55	1	410	685	825	15-62	188	80	30	22	4	120	60	98	52	M10	20	17		
	20-60				118														
65	1	625	940	1175	22-70	185	75	35	26	4.5	135	68	115	61	M10	20	17		
75	1	1280	1920	2400	30-80	210	85	40	30	5	160	80	135	69	M10	25	17		
90	1	2400	3600	4500	40-100	245	100	45	34	5.5	200	100	160	81	M12	30	40		

ROTEX® Nodular iron (GJS)																			
Size	Component	Spider ¹⁾ (component 2) Rated torque [Nm]			Finish bore d	Dimensions [mm]													
		92 ShA	98 ShA	64 ShD		General													
					L	l ₁ , l ₂	E	b	s	D _H	d _H	D	N	G	t	T _A [Nm]			
100	1	3300	4950	6185	50-115	270	110	50	38	6	225	113	180	89	M12	30	40		
110	1	4800	7200	9000	60-125	295	120	55	42	6.5	255	127	200	96	M16	35	80		
125	1	6650	10000	12500	60-145	340	140	60	46	7	290	147	230	112	M16	40	80		
140	1	8550	12800	16000	60-160	375	155	65	50	7.5	320	165	255	124	M20	45	140		
160	1	12800	19200	24000	80-185	425	175	75	57	9	370	190	290	140	M20	50	140		
180	1	18650	28000	35000	85-200	475	195	85	64	10.5	420	220	325	156	M20	50	140		

■ Unless any material is specified in the order, it is defined with the calculation/order.

¹⁾ Maximum torque of the coupling T_{K max} = rated torque of the coupling T_{K rated} x 2. For selection see page 14 et seqq.

Ordering example:	ROTEX® 38	GJL	92 ShA	1a	Ø 45	1	Ø 25
	Coupling size	Material	Spider hardness	Component	Finish bore	Component	Finish bore

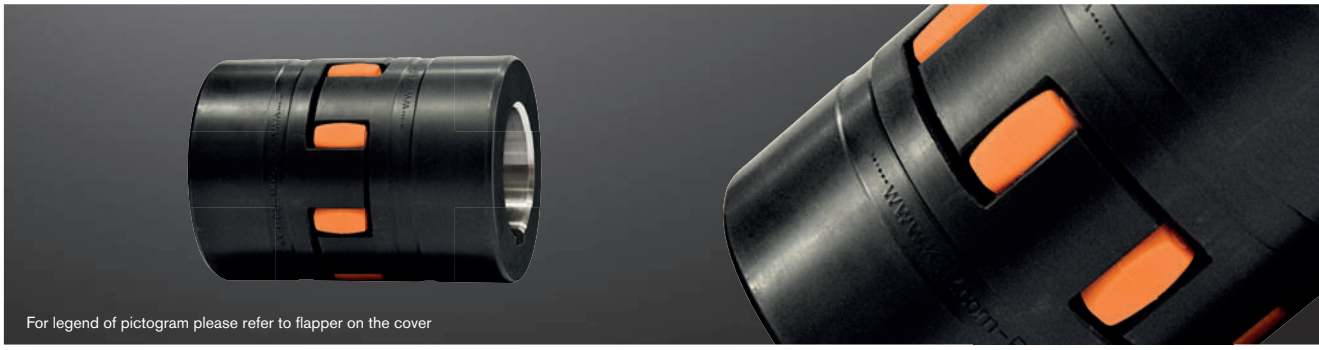

For legend of pictogram please refer to flapper on the cover



ROTEX® with CDP coating ¹⁾

Size	Component	Spider (component 2) Rated torque [Nm]			Finish bore d (min. - max.)	Dimensions [mm]											Thread for setscrews		
		92 ShA	98 ShA	64 ShD		General											G	t	T _A [Nm]
						L	l ₁ , l ₂	E	b	s	D _H	d _H	D	N					
19	1a	10	17	21	0-25	66	25	16	12	2	40	18	40	-	M5	10	2		
24	1a	35	60	75	0-35	78	30	18	14	2	55	27	55	-	M5	10	2		
28	1a	95	160	200	0-40	90	35	20	15	2.5	65	30	65	-	M8	15	10		
38	1	190	325	405	0-48	114	45	24	18	3	80	38	70	27	M8	15	10		
42	1	265	450	560	0-55	126	50	26	20	3	95	46	85	28	M8	20	10		
48	1	310	525	655	0-62	140	56	28	21	3.5	105	51	95	32	M8	20	10		
55	1	410	685	825	0-74	160	65	30	22	4	120	60	110	37	M10	20	17		
65	1	625	940	1175	0-80	185	75	35	26	4.5	135	68	115	47	M10	20	17		
75	1	1280	1920	2400	0-95	210	85	40	30	5	160	80	135	53	M10	25	17		
90	1	2400	3600	4500	0-110	245	100	45	34	5.5	200	100	160	62	M12	25	40		
100	1	3300	4950	6185	0-115	270	110	50	38	6	225	113	180	89	M12	30	40		
110	1	4800	7200	9000	0-125	295	120	55	42	6.5	255	127	200	96	M16	35	80		
125	1	6650	10000	12500	60-145	340	140	60	46	7	290	147	230	112	M16	40	80		

¹⁾ Corrosion protection class acc. to DIN EN ISO 12944: Min. C4, heavy-long

Components

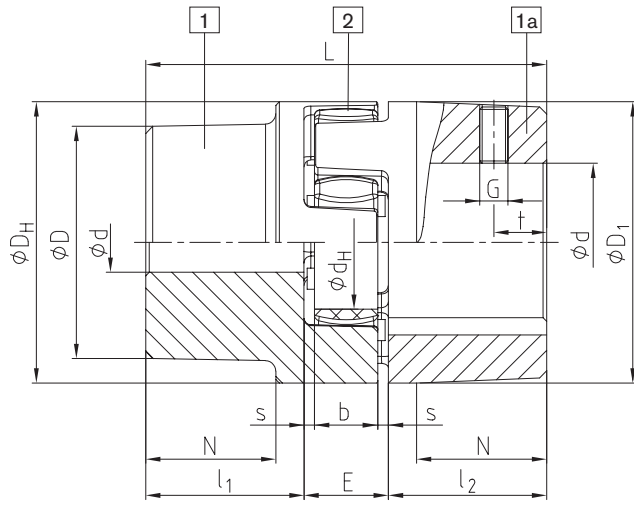

AI-D (thread opposite the keyway)

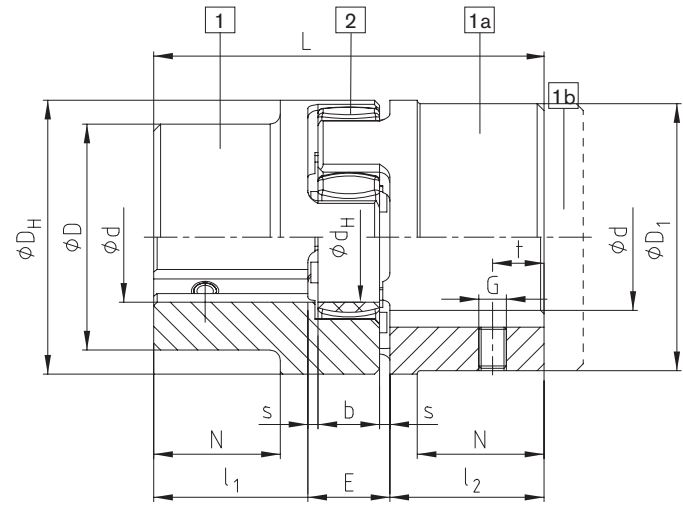

GJL / GJS (thread on the keyway)

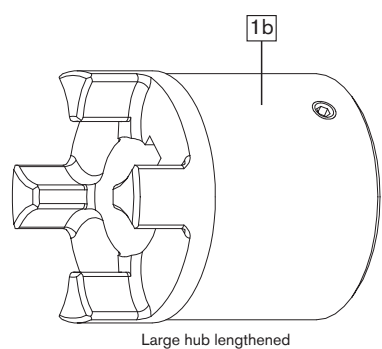
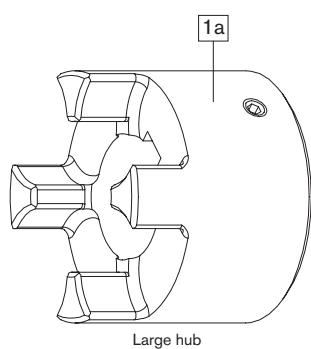
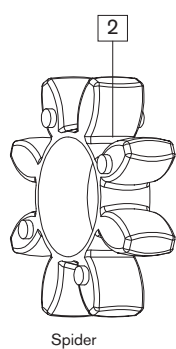
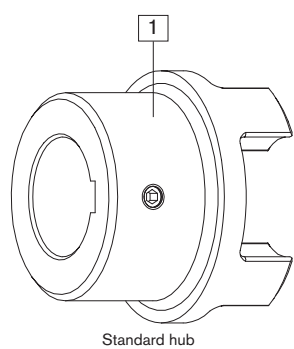

ROTEX® Standard Flexible jaw couplings

Material steel/stainless steel

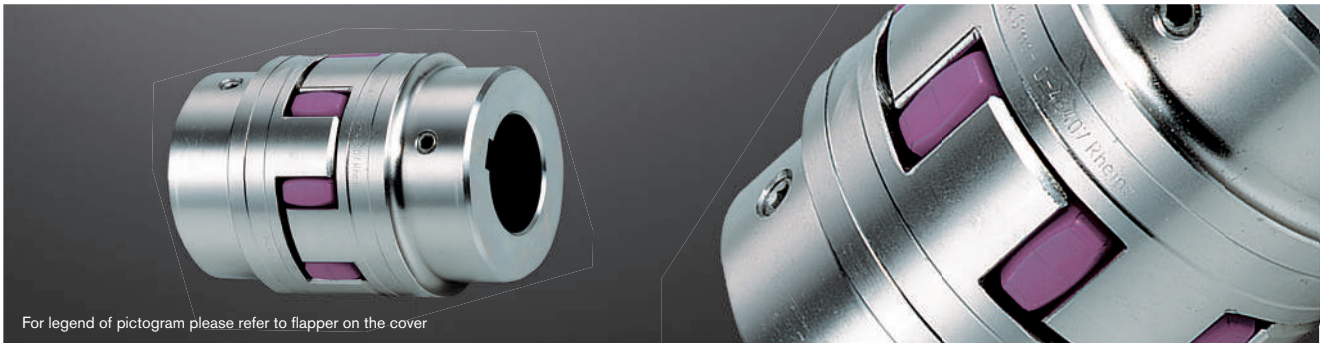

For legend of pictogram please refer to flapper on the cover

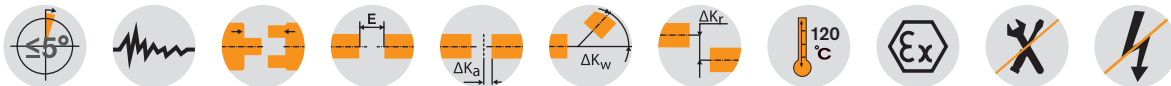

ROTEX® Steel (St)

Size	Component	Spider ¹⁾ (component 2) Rated torque [Nm]			Finish bore d (min. - max.)	Dimensions [mm]											Thread for setscrews		
		92 ShA	98 ShA	64 ShD		General											G	t	T _A [Nm]
						L	l _{1,2}	E	b	s	D _H	d _H	D	N					
14	1a	7.5	12.5	16	0-16	35	11	13	10	1.5	30	10	30	—	M4	5	1.5		
	50					18.5													
19	1a	10	17	21	0-25	66	25	16	12	2	40	18	40	—	M5	10	2		
	90					37													
24	1a	35	60	75	0-35	78	30	18	14	2	55	27	55	—	M5	10	2		
	118					50													
28	1a	95	160	200	0-40	90	35	20	15	2.5	65	30	65	—	M8	15	10		
	140					60													
38	1	190	325	405	0-48	114	45	24	18	3	80	38	70	27	M8	15	10		
	164					70	80						—						
42	1	265	450	560	0-55	126	50	26	20	3	95	46	85	28	M8	20	10		
	176					75	95						—						
48	1	310	525	655	0-62	140	56	28	21	3.5	105	51	95	32	M8	20	10		
	188					80	105						—						
55	1	410	685	825	0-75	160	65	30	22	4	120	60	110	37	M10	20	17		
	210					90	120						—						
65	1	625	940	1175	0-80	185	75	35	26	4.5	135	68	115	47	M10	20	17		
	235					100	135						—						
75	1	1280	1920	2400	0-95	210	85	40	30	5	160	80	135	53	M10	25	17		
	260					110	160						—						
90	1	2400	3600	4500	0-110	245	100	45	34	5.5	200	100	160	62	M12	30	40		
	295					125	200						—						
100	1	3300	4950	6185	0-115	270	110	50	38	6	225	113	180	89	M12	30	40		
110	1	4800	7200	9000	0-125	295	120	55	42	6.5	255	127	200	96	M16	35	80		
125	1	6650	10000	12500	60-145	340	140	60	46	7	290	147	230	112	M16	40	80		
140	1	8550	12800	16000	60-160	375	155	65	50	7.5	320	165	255	124	M20	45	140		
160	1	12800	19200	24000	80-185	425	175	75	57	9	370	190	290	140	M20	50	140		
180	1	18650	28000	35000	85-200	475	195	85	64	10.5	420	220	325	156	M20	50	140		

■ = Unless any material is specified in the order, it is defined with the calculation/order.

¹⁾ Maximum torque of the coupling T_{K max} = rated torque of the coupling T_{K rated} x 2. For selection see page 14 et seqq.

ROTEX® Stainless steel

Size	Material	Spider (component 2) Rated torque [Nm]			Finish bore d (min. - max.)	Dimensions [mm]											Thread for setscrews		
		92 ShA	98 ShA	64 ShD		General											G	t	T _A [Nm]
						L	l _{1,2}	E	b	s	D _H	d _H	D	N					
19	1.4305	10	17	21	0-25	66	25	16	12	2	40	18	40	-	M5	10	2		
24	1.4571	35	60	75	0-35	78	30	18	14	2	55	27	55	-	M5	10	2		
28	1.4305	95	160	200	0-40	90	35	20	15	2.5	65	30	65	-	M8	15	10		
38	1.4571	190	325	405	0-48	114	45	24	18	3	80	38	80	27	M8	15	10		
42	1.4305	265	450	560	0-55	126	50	26	20	3	95	46	95	28	M8	20	10		
48	1.4571	310	525	655	0-62	140	56	28	21	3.5	105	51	105	32	M8	20	10		

Ordering example:

ROTEX® 38	St	92 ShA	1 - Ø45	1 - Ø25
Coupling size	Material	Spider hardness	Component Finish bore	Component Finish bore

ROTEX® Flexible jaw couplings

DIN EN 10204 - 3.1 and 3.2 material test certificate

Components

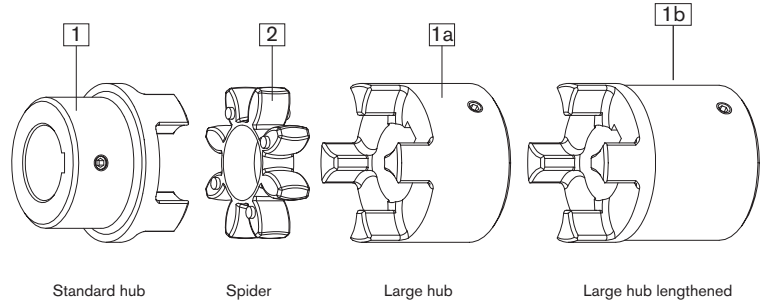
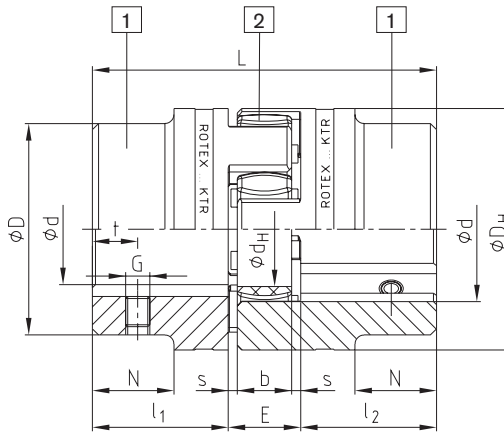

Steel (thread on the keyway)

ROTEX® Coupling hubs with test certificate ¹⁾				
Size	Component	Material ²⁾	Inspection certificate acc. to DIN EN 10204	Notch impact strength
19	1a	S355 ²⁾	3.1	>=27 J
24	1a	S355 ²⁾	3.1	>=27 J
28	1a	S355 ²⁾	3.1	>=27 J
38	1a	S355 ²⁾	3.1	>=27 J
42	1	S355 ²⁾	3.1	>=27 J
48	1	S355 ²⁾	3.1	>=27 J
55	1	S355 ²⁾	3.1	>=27 J
65	1	S355 ²⁾	3.1	>=27 J
75	1	S355 ²⁾	3.1/3.2	>=27 J
		42CrMoS4+QT ³⁾		
90	1	S355 ²⁾	3.1/3.2	>=27 J
		42CrMoS4+QT ³⁾		
100	1	S355 ²⁾	3.1/3.2	>=27 J
		42CrMoS4+QT ³⁾		
110	1	S355 ²⁾	3.1/3.2	>=27 J
		42CrMoS4+QT ³⁾		
120	1	S355 ²⁾	3.1/3.2	>=27 J
		42CrMoS4+QT ³⁾		
140	1	S355 ²⁾	3.1/3.2	>=27 J
		42CrMoS4+QT ³⁾		
160	1	S355 ²⁾	3.1/3.2	>=27 J
		42CrMoS4+QT ³⁾		
180	1	S355 ²⁾	3.1/3.2	>=27 J
		42CrMoS4+QT ³⁾		

¹⁾ S355 suitable for feather key connections, 42CrMoS4+QT for oil press-fits

²⁾ Notch impact strength with -40 °C

³⁾ Notch impact strength with -20 °C

Marine programme:

Hub materials S355J2+N and 42CrMo4+QT acc. to DIN EN 10204 - 3.1+3.2, size 75 - 180 available from stock.



UL



Use in fire pumps

ROTEX® couplings comply with the specifications of NFPA 20 standard for the installation of stationary pumps for fire protection and due to completion of the endurance tests required they also comply with the specifications of UL 448A, flexible couplings and connection shafts for stationary fire pumps.

Sizes available:



ROTEX® UL Listed								
Size	Component	Material	Spider (component 2) Rated torque [Nm] 92 ShA	Dimensions [mm]				
				Finish bore d (min. - max.)	L	l _{1,2}	E	D _H
42	1	St	265	18-55	126	50	26	95
55	1	St	410	24-74	160	65	30	120
65	1	St	625	24-80	185	75	35	135
75	1	St	1280	24-95	210	85	40	160
90	1	St	2400	30-110	245	100	45	200

* for complete dimensions see table on page 36

ROTEX® Flexible jaw couplings

Taper clamping sleeve



For legend of pictogram please refer to flapper on the cover



Components

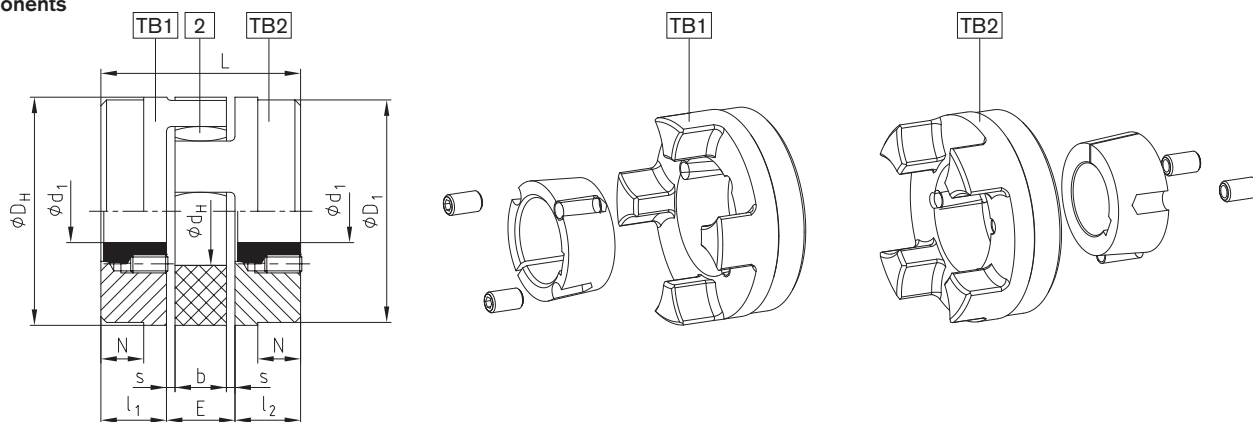

ROTEX® Shaft coupling for taper clamping sleeve

Size	Taper clamping sleeve	Dimensions [mm]									Fastening screws for taper clamping sleeves				
		l_1, l_2	E	s	b	L	N	D_H	D_1	d_H	Size [Inch] ¹⁾	Length [mm]	Quantity	T_A [Nm]	
24	1008	22	18	2.0	14	62	–	55	55	27	1/4"	13	2	5.7	
28	1108	23	20	2.5	15	66	–	65	65	30	1/4"	13	2	5.7	
38	1108	23	24	3.0	18	70	15	80	78	38	1/4"	13	2	5.7	
42	1610	26	26	3.0	20	78	16	95	94	46	3/8"	16	2	20	
48	1615	39	28	3.5	21	106	28	105	104	51	3/8"	16	2	20	
55	2012	33	30	4.0	22	96	20	120	118	60	7/16"	22	2	31	
65	2012	33	35	4.5	26	101	19	135	115	68	7/16"	22	2	31	
75	2517	52	40	5.0	30	144	36	160	158	80	1/2"	25	2	49	
	5/8"										32	92			
90	3020	52	45	5.5	34	149	33	200	160	100	3/8"	32	2	92	
100	3535	90	50	6	38	230	69	225	180	113	1/2"	49	3	113	
125	4545	114	60	7.0	46	288	86	290	230	147	3/4"	49	3	192	

Taper clamping sleeve

Size	Summary of bore dimensions d_1 [mm], H7 fit- feather keyway acc. to DIN 6885 sheet 1																		
1008	Ø10	Ø11	Ø12	Ø14	Ø16	Ø18	Ø19	Ø20	Ø22	Ø24	Ø25								
1108	Ø10	Ø11	Ø12	Ø14	Ø16	Ø18	Ø19	Ø20	Ø22	Ø24	Ø25	Ø28 ²⁾							
1610	Ø14	Ø16	Ø18	Ø19	Ø20	Ø22	Ø24	Ø25	Ø28	Ø30	Ø32	Ø35	Ø38	Ø40	Ø42 ²⁾				
1615	Ø14	Ø16	Ø18	Ø19	Ø20	Ø22	Ø24	Ø25	Ø28	Ø30	Ø32	Ø35	Ø38	Ø40	Ø42 ²⁾				
2012	Ø14	Ø16	Ø18	Ø19	Ø20	Ø22	Ø24	Ø25	Ø28	Ø30	Ø32	Ø35	Ø38	Ø40	Ø42	Ø45	Ø48	Ø50	
2517	Ø16	Ø18	Ø19	Ø20	Ø22	Ø24	Ø25	Ø28	Ø30	Ø32	Ø35	Ø38	Ø40	Ø42	Ø45	Ø48	Ø50	Ø55	Ø60
3020	Ø25	Ø28	Ø30	Ø35	Ø38	Ø40	Ø42	Ø45	Ø48	Ø50	Ø55	Ø60	Ø65	Ø70	Ø75				
3535	Ø35	Ø38	Ø40	Ø42	Ø45	Ø48	Ø50	Ø55	Ø60	Ø65	Ø70	Ø75	Ø80	Ø85	Ø90				
4545	Ø55	Ø60	Ø65	Ø70	Ø75	Ø80	Ø85	Ø90	Ø95	Ø100	Ø105	Ø110							

• Available for type TB2 only

¹⁾ 1. BSW thread

Coupling type TB1/TB2, TB1/TB1 and TB2/TB2 possible.

Please order our separate dimension sheet (M373054).

²⁾ Bores with feather keyway (flat design) acc. to DIN 6885 sheet 3

Ordering example:

ROTEX® 38	92 ShA	1108	TB1 - Ø 24		TB2 - Ø 22	
Coupling size	Spider hardness	Taper clamping sleeve	Hub design	Finish bore	Hub design	Finish bore

ROTEX® Flexible jaw couplings

Clamping ring hubs

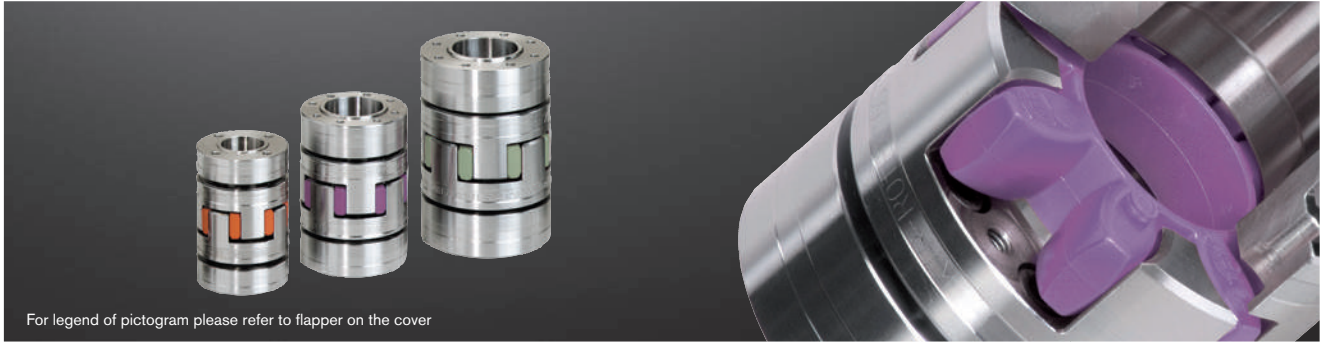

For legend of pictogram please refer to flapper on the cover



Components

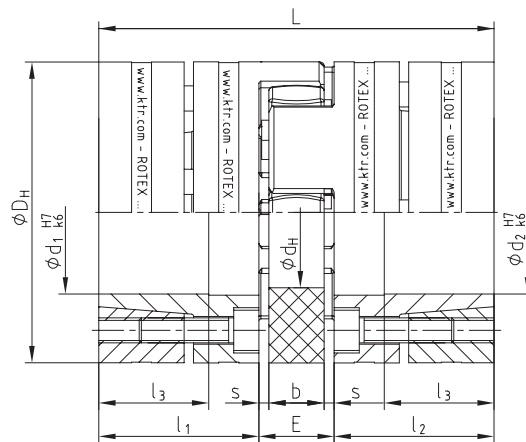

Tack thread M1 between clamping screws.

Size	Torques [Nm] ¹⁾				Dimensions [mm]								Clamping screws			Weight per hub with max. bore [kg]	Mass moment of inertia per hub with max. bore [kgm ²]	
	92 ShA		98 ShA		DH ²⁾	dH	L	l _{1,2}	l ₃	E	b	s	M	z = number	T _A [Nm]			M ₁
	T _{KN}	T _{K max}	T _{KN}	T _{K max}														
19	10.0	20	17	34	40	18	66	25	18	16	12	2.0	M4	6	4.1	M4	0.179	0.44 x 10 ⁻⁴
24	35.0	70	60	120	55	27	78	30	22	18	14	2.0	M5	4	8.5	M5	0.399	1.91 x 10 ⁻⁴
28	95.0	190	160	320	65	30	90	35	27	20	15	2.5	M5	8	8.5	M5	0.592	4.18 x 10 ⁻⁴
38	190.0	380	325	650	80	38	114	45	35	24	18	3.0	M6	8	14	M6	1.225	12.9 x 10 ⁻⁴
42	265	530	450	900	95	46	126	50	35	26	20	3.0	M8	4	35	M8	2.30	31.7 x 10 ⁻⁴
48	310	620	525	1050	105	51	140	56	41	28	21	3.5	M10	4	69	M10	3.08	52.0 x 10 ⁻⁴
55	375	750	685	1370	120	60	160	65	45	30	22	4.0	M10	4	69	M10	4.67	103.0 x 10 ⁻⁴
65	—	—	940	1880	135	68	185	75	55	35	26	4.5	M12	4	120	M12	6.70	191.0 x 10 ⁻⁴
75	—	—	1920	3840	160	80	210	85	63	40	30	5.0	M12	5	120	M12	9.90	396.8 x 10 ⁻⁴
90	—	—	3600	4500	200	104	245	100	75	45	34	5.5	M16	5	295	M16	17.70	1136 x 10 ⁻⁴

Size	Bore d ₁ /d ₂ and the respective transmittable friction torques T _R of clamping ring hub in [Nm] ¹⁾																											
	Ø10	Ø11	Ø14	Ø15	Ø16	Ø19	Ø20	Ø24	Ø25	Ø28	Ø30	Ø32	Ø35	Ø38	Ø40	Ø42	Ø45	Ø48	Ø50	Ø55*	Ø60*	Ø65*	Ø70*	Ø80*	Ø90*	Ø95*	Ø100*	Ø105*
19	27	32	69	84	57	94	110																					
24			70	87	56	97	114	116	133	192																		
28				108	131	207	148	253	285	315	382	330	433	503														
38							208	353	395	439	531	463	603	593	689	793	776											
42									445	495	595	526	678	671	775	718	872	1043	1061									
48											616	704	899	896	1030	962	1160	1379	1222	1543								
55													863	856	991	918	1119	1110	1247	1277	1665	1605	2008					
65															1446	1355	1637	1635	1827	1887	2429	2368	2930					
75																1710	2053	2059	2294	2384	3040	2983	3664	4293				
90																			3845	4249	4794	5858	5900	7036	8047	9247	9575	10845

¹⁾ For selection see page 14 et seqq.

²⁾ ØD_H + 2 mm with high speeds for expansion of spider

The transmittable torques of the clamping connection include the max. fitting tolerance with shaft clearance k6/bore H7, from Ø55 G7/m6. The torque is reduced with bigger fitting tolerances. For the strength calculation of shaft/hollow shaft see KTR standard 45510 at our homepage www.ktr.com.

Ordering example:	ROTEX® GS 24	98 ShA	6.0 steel	Ø24	6.0 steel	Ø20
	Coupling size	Spider hardness	Hub design	Finish bore	Hub design	Finish bore

ROTEX® Flexible jaw couplings

Clamping hubs



For legend of pictogram please refer to flapper on the cover



Components

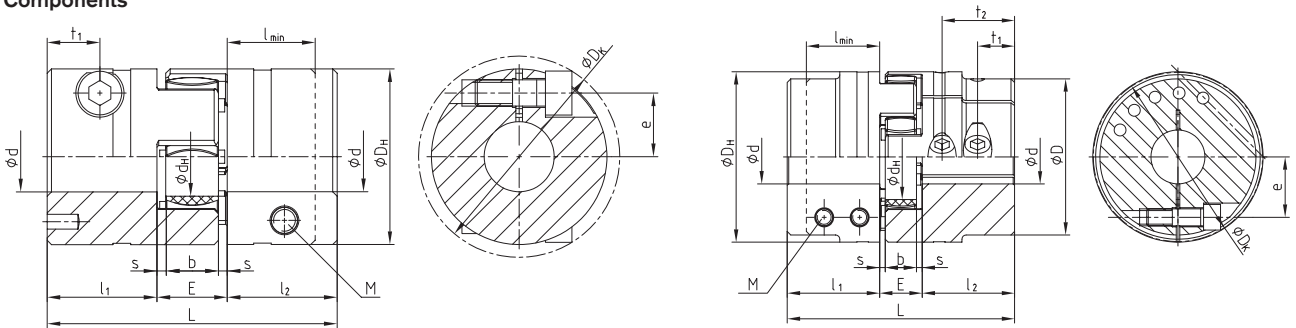

ROTEX® 19 - 28

ROTEX® 38 - 90

ROTEX® as clamping hubs																
Size	Dimensions [mm]														Screw DIN EN ISO 4762	
	Max. d	L	l_1, l_2	l_{min}	E	b	s	D_H	D	d_H	D_K	t_1	t_2	e	M	T_A [Nm]
19	20 ¹⁾	66	25	20	16	12	2.0	40	-	18	46.0	12	—	14.5	M6	14
24	28	78	30	25	18	14	2.0	55	-	27	57.5	12	—	20.0	M6	14
28	38	90	35	30	20	15	2.5	65	-	30	73.0	14 ²⁾	—	25.0	M8	35
38	42	114	45	35	24	18	3.0	80	70	38	77.5	19	—	26.5	M8	35
42	50	126	50	42	26	20	3.0	95	85	46	93.5	18 ²⁾	—	32.0	M10	69
48	55	140	56	46	28	21	3.5	105	95	51	105.0	21 ²⁾	—	36.0	M12	120
55	68	160	65	50	30	22	4.0	120	110	60	119.5	26	51 ²⁾	42.5 ³⁾	M12	120
65	70	185	75	55	35	26	4.5	135	115	68	132.5	33	61 ²⁾	50.0 ³⁾	M12	120
75	80	210	85	65	40	30	5.0	160	135	80	158.0	36	68 ²⁾	57.0 ³⁾	M16	295
90	90	245	100	80	45	34	5.5	200	160	100	197.0	40	80 ²⁾	72.0 ³⁾	M20	580

Bore d_1/d_2 and the respective transmittable friction torques T_R [Nm] of ROTEX® clamping hubs design 2.0																														
Size	Ø8	Ø10	Ø11	Ø14	Ø15	Ø16	Ø18	Ø19	Ø20	Ø22	Ø24	Ø25	Ø28	Ø30	Ø32	Ø35	Ø38	Ø40	Ø42	Ø45	Ø48	Ø50	Ø55	Ø60	Ø65	Ø70	Ø75	Ø80	Ø85	Ø90
19	44	46	47	51	52	53	55	57	58																					
24		59	60	64	65	66	68	70	71	73	76	77	80																	
28				139	141	144	148	150	152	157	161	163	170	174	178	185	191													
38					163	165	170	172	174	178	183	185	192	196	200	207	213	217	222											
42									291	297	304	308	318	325	332	342	353	360	367	377	387	394								
48									466	476	486	491	506	516	526	542	557	567	577	592	607	618	643							
55															1185	1215	1245	1266	1286	1316	1347	1367	1417	1468	1519					
65																1316	1347	1367	1387	1417	1448	1468	1519	1569	1620	1671				
75																	2869	2926	2983	3022	3117	3213	3309	3404	3500	3595				
90																	5220	5310	5400	5460	5610	5760	5910	6060	6210	6360	6510	6660		

¹⁾ With type 2.1 d_{max} Ø17 mm

²⁾ With reduced hubs dimension t_1 varies or the number of screws changes from 2-off to 1-off

³⁾ t_1 and t_2 have a different dimension e

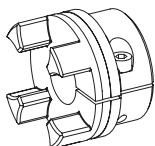

Type 2.0
Clamping hub single slot without feather keyway

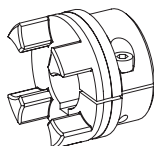

Type 2.1
Clamping hub single slot with feather keyway

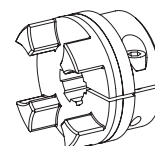

Type 2.3
Clamping hub with spline bore (For a selection of our programme of spline bores see page 32)

Ordering example:	ROTEX® 24	98 ShA	2.1	Ø24	2.0	Ø20
		Coupling size	Spider hardness	Hub design	Finish bore	Hub design

ROTEX® AFN and BFN Flexible jaw couplings

Flange programme

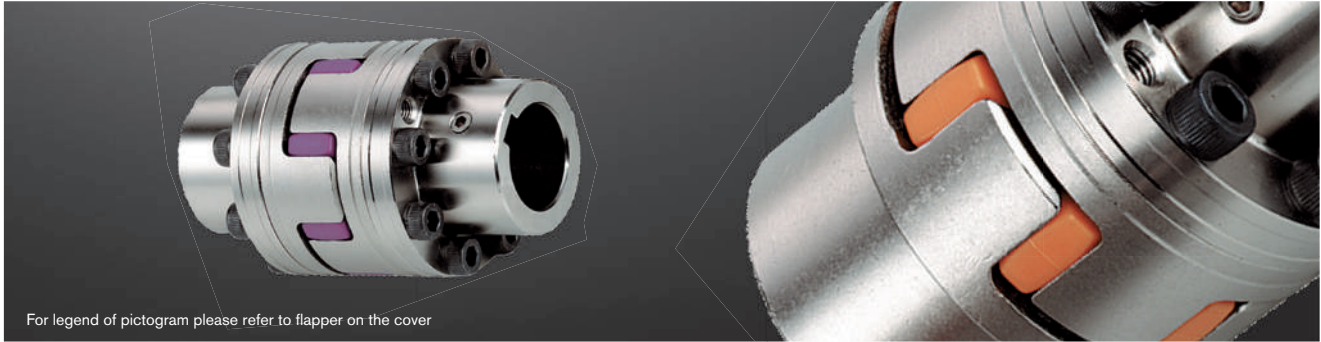

For legend of pictogram please refer to flapper on the cover

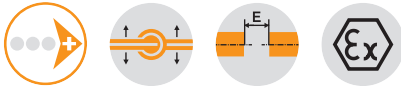

Components

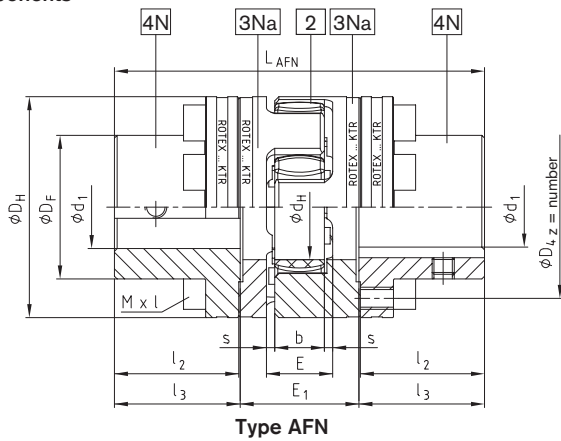

Type AFN

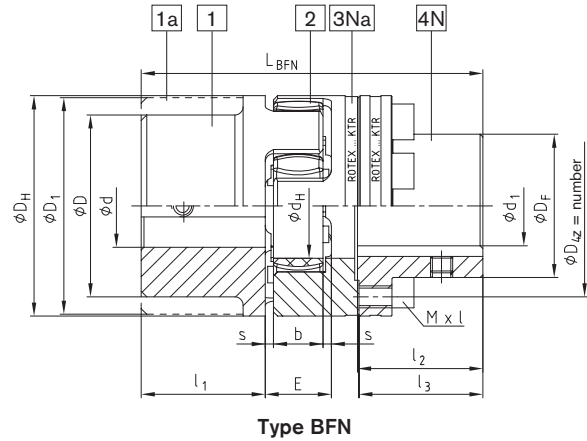

Type BFN

ROTEX® Type AFN and BFN																		
Size	Pilot bore d, D, D ₁	Component 4N max. finish bore d ₁	Dimensions [mm]													Cap screws ³⁾ DIN EN ISO 4762 - 12.9		
			D _H	D _F	D ₄	d _H	l ₁ , l ₂	E	E ₁	s	b	l ₃ ; l ₄	L _{AFN}	L _{BFN}	Mxl	z	pitch ²⁾	T _A ¹⁾ [Nm]
24	See jaw couplings on page 34 to 36 For stock programme / basic programme see page 32 and 33	27	55	36	45	27	30	18	33	2.0	14	30.5	94	86	M5x16	8		10
28		30	65	42	54	30	35	20	39	2.5	15	35.5	110	100	M6x20	8	8x45°	17
38		38	80	52	66	38	45	24	43	3.0	18	45.5	134	124	M8x22	8		41
42		45	95	62	80	46	50	26	48	3.0	20	51.0	150	138	M8x25	12		41
48		50	105	70	90	51	56	28	50	3.5	21	57.0	164	152	M8x25	12	16x22.5°	41
55		60	120	80	102	60	65	30	60	4.0	22	66.0	192	176	M10x30	8	8x45°	83
65		70	135	94	116	68	75	35	65	4.5	26	76.0	217	201	M10x30	12	16x22.5°	83
75		80	160	108	136	80	85	40	75	5.0	30	86.5	248	229	M12x40	15		120
90		105	200	142	172	100	100	45	82	5.5	34	101.5	285	265	M16x40	15		295
100		115	225	158	195	113	110	50	97	6.0	38	111.5	320	295	M16x50	15		295
110		130	255	178	218	127	120	55	103	6.5	42	122.0	347	321	M20x50	15	20x18°	580
125		150	290	206	252	147	140	60	116	7.0	46	142.0	400	370	M20x60	15		580
140		170	320	235	282	165	155	65	128	7.5	50	157.5	443	409	M20x60	15		580
160		200	370	270	325	190	175	75	146	9.0	57	177.5	501	463	M24x70	15		1000
180		230	420	315	375	220	195	85	159	10.5	64	198.0	555	515	M24x80	18	24x15°	1000

¹⁾ Screw tightening torque T_A [Nm].
²⁾ Thread in the driving flange between the cams.
³⁾ Coupling is delivered not assembled.

Ordering example:	ROTEX® 24	AFN	92 ShA	4N	Ø38	4N	Ø35
	Coupling size	Type	Spider hardness	Component	Finish bore	Component	Finish bore

ROTEX® A-H

Flexible jaw couplings

Drop-out center design coupling

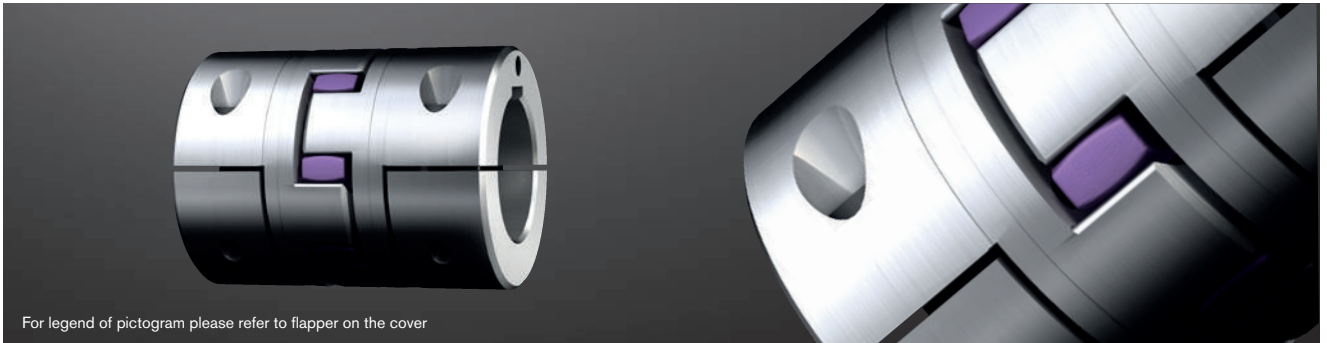

For legend of pictogram please refer to flapper on the cover

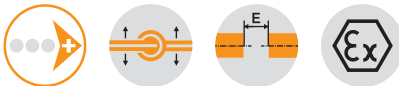

Components

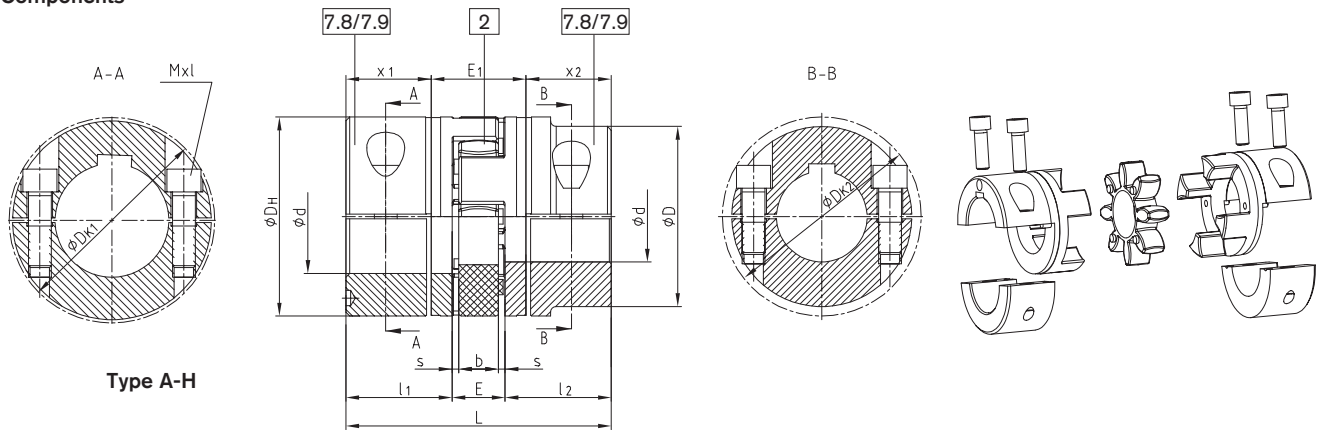

ROTEX® Type A-H														
Size	Max. finish bore d	Dimensions [mm]											Cap screws DIN EN ISO 4762	
		L	l ₁ , l ₂	E	b	s	D _H	D	DK1	DK2	x ₁ , x ₂	E ₁	Mxl	Tightening torque T _A [Nm]
19	20	66	25	16	12	2.0	40	—	46	—	17.5	31	M6x16	14
24	28	78	30	18	14	2.0	55	—	57.5	—	22.5	33	M6x20	14
28	38	90	35	20	15	2.5	65	—	73	—	25.5	39	M8x25	35
38	45	114	45	24	18	3.0	80	—	83.5	—	35.5	43	M8x30	35
42	50	126	50	26	20	3.0	95	85	—	93.5	39	48	M10x30	69
	55							—	97	M10x35				
48	55	140	56	28	21	3.5	105	95	—	105	45	50	M12x35	120
	60							—	108.5	M12x40				
55	65	160	65	30	22	4.0	120	110	—	119.5	50	60	M12x40	120
	70							—	122	M12x45				
65	70	185	75	35	26	4.5	135	115	—	123.5	60	65	M12x40	120
	80							—	132.5	M12x45				
75	80	210	85	40	30	5.0	160	135	—	147.5	67.5	75	M16x50	295
	90							—	158	M16x50				
90	90	245	100	45	34	5.5	200	160	—	176	81.5	82	M20x60	580
	110							—	197	M20x60				
100 ¹⁾	110	270	110	50	38	6.0	225	180	—	185.5	84	102	M16x50	295
110 ¹⁾	120	295	120	55	42	6.5	255	200	—	208	90	115	M20x60	580
125 ¹⁾	140	340	140	60	46	7.0	290	230	—	242.5	105	130	M24x70	1000

CAUTION:

With maximum bore the feather keyways are offset to each other by approx. 5°
Hub material up to size 90: steel, from size 100: GJS

7.8 = Shell clamping hub without feather key max. circumferential speed of v = 35 m/s.

From a circumferential speed of v = 25 m/s the frictional torque of shaft/hub has to be reviewed. Please consult with KTR engineering department.

7.9 = Shell clamping hub with feather key max. circumferential speed of v = 35 m/s. From a circumferential speed of v = 25 m/s dynamic balancing is required.

Speed: max. circumferential speed of 25 m/s on the outside diameter D_H of the coupling

¹⁾ From size 100: 4 clamping screws for each clamping hub

Ordering example:	ROTEX® 38	A-H	98 ShA	7.8	Ø38	7.8	Ø30
	Coupling size	Type	Spider hardness	Hub design	Finish bore	Hub design	Finish bore

ROTEX® S-H Flexible jaw couplings

Drop-out center design coupling with SPLIT hubs

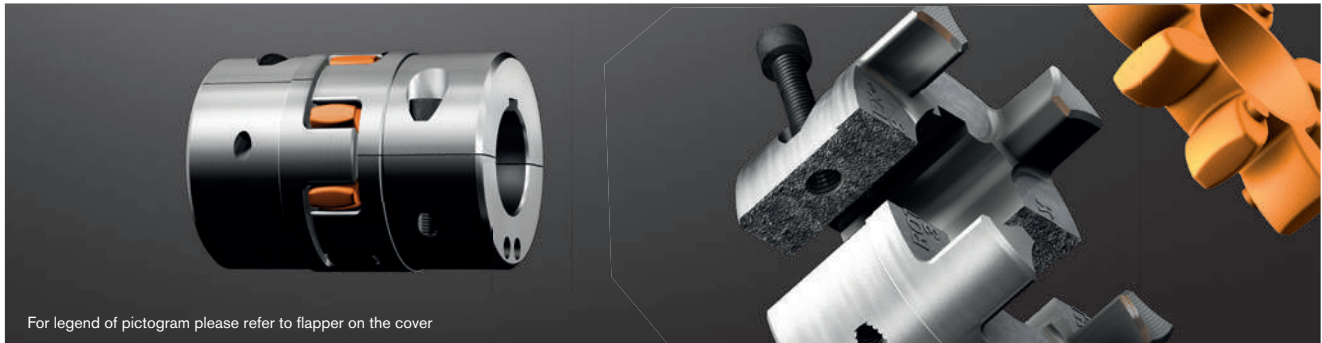

For legend of pictogram please refer to flapper on the cover

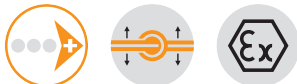

Components

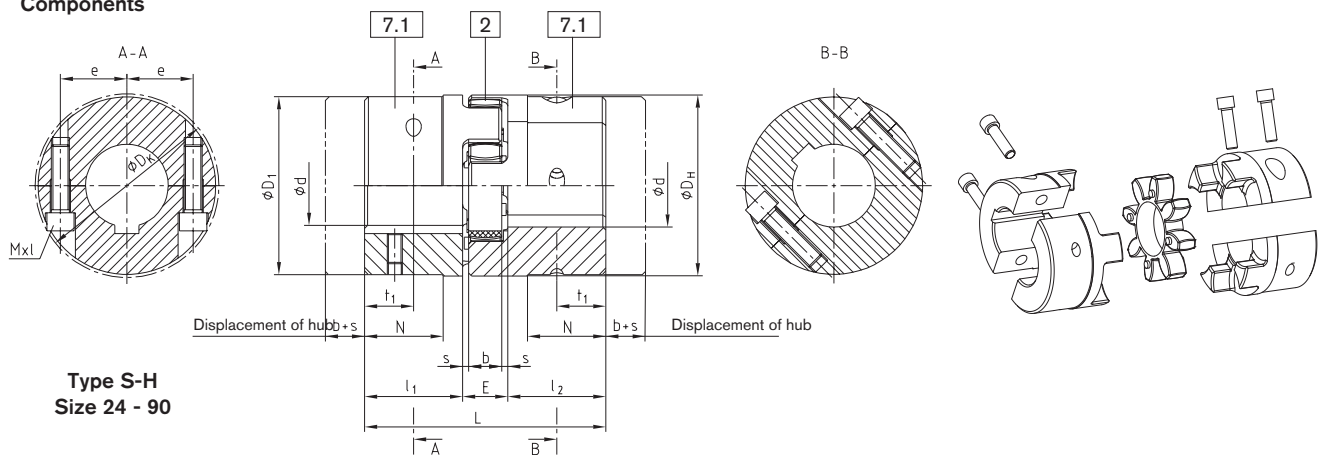

ROTEX® Type S-H Powder metal steel (Sint)																	
Size	Finish bore d		Dimensions [mm]													Cap screws DIN EN ISO 4762	
	Min.	Max.	L	l_1, l_2	E	b	s	DH	D1	DK	N	e	t1	t2	G	Mxl	Tightening torque T_A [Nm]
24	0	24	78	30	18	14	2	55	-	57.5	-	20	15	10	M5	M6x20	14
28	0	38	90	35	20	15	2.5	65	-	73	-	25	17.5	15	M8	M8x25	34

ROTEX® Type S-H Cast iron (GJL)																	
Size	Finish bore d		Dimensions [mm]													Cap screws DIN EN ISO 4762	
	Min.	Max.	L	l_1, l_2	E	b	s	DH	D1	DK	N	e	t1	t2	G	Mxl	Tightening torque T_A [Nm]
38	24	45	114	45	24	18	3	80	78	83.5	37	30	22.5	15	M8	M8x30	34
42	24	55	126	50	26	20	3	95	94	97	40	30	25	M10x35		67	
48	24	60	140	56	28	21	3.5	105	104	108.5	45	35	28	M10	M12x40	115	
55	24	70	160	65	30	22	4	120	118	122	52	40	32.5		20	M12x45	115
65	24	70	185	75	35	26	4.5	135	115	123.5	61	45	37.5			M12x40	115
	70	80							135	132.5		50				M10	
75	40	80	210	85	40	30	5	160	135	147	69	51	42.5	25		M16x50	290
	80	90							160	158		57					
90	40	90	245	100	45	34	5.5	200	160	176	81	60	50	30	M12	M20x60	560
	90	110							200	197		72					

7.1 = SPLIT hub with feather keyway

Ordering example:	ROTEX® 38	S-H	98 ShA	7.1	Ø38	7.1	Ø30
	Coupling size	Type	Spider hardness	Hub design	Finish bore	Hub design	Finish bore

ROTEX® SP GN and EN Flexible jaw couplings

Single-cardanic shaft coupling (Non Sparking)

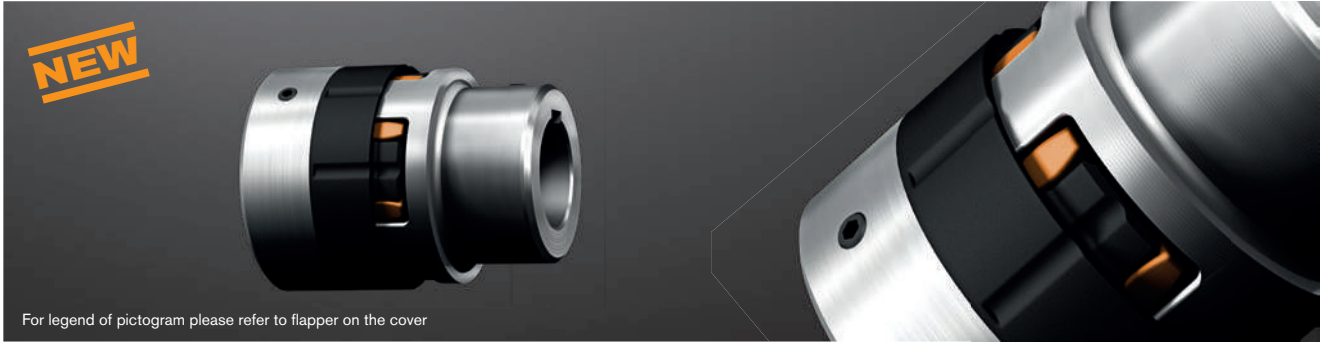

For legend of pictogram please refer to flapper on the cover

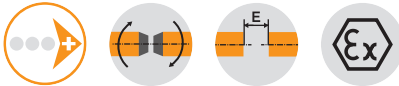

Components

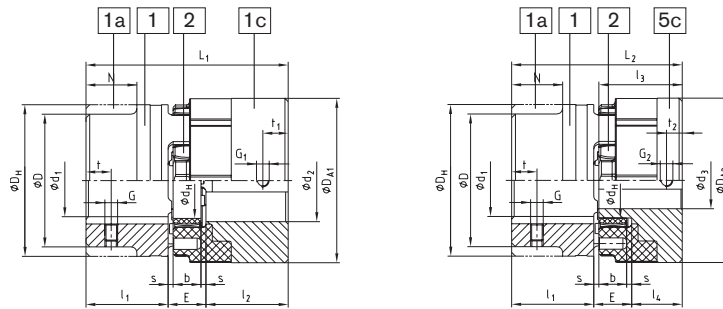

ROTEX® Standard (St) ³⁾			ROTEX® SP Type GN							ROTEX® SP Type EN							
Size	Spider ¹⁾ (component 2) Rated torque [Nm]	Component steel (St)	Component SP	Dimensions [mm] ROTEX® SP component 1c						Component SP	Dimensions [mm] ROTEX® SP component 5c						
				max. d ₂ ²⁾	l ₂	DA ₁	G ₁	t ₁	L ₁		max. d ₂ ²⁾	l ₃	l ₄	DA ₂	G ₂	t ₂	L ₂
24	35	1a	1c	28	30	61	M5	10	78	5c	19	36	22	61	M5	6	70
		98							90								81
28	95	1a	1c	32	35	72	M8	15	115	5c	22	42	26	72	M8	7	106
		114							139								99
38	190	1	1c	42	45	87	M8	15	126	5c	28	50	30	87	M8	7	124
		151							140								120
42	265	1	1c	48	50	103	M8	20	160	5c	35	56	34	103	M8	10	135
		164							160								124
48	310	1	1c	55	56	114	M8	20	185	5c	40	60	36	114	M8	10	154
		210							185								154
55	410	1	1c	65	65	130	M10	20	185	5c	45	66	40	130	M10	17	160
		210							185								154
65	625	1	1c	75	75	146	M10	20	210	5c	55	75	44	146	M10	17	179
		210							185								154

ROTEX® Standard (GJL) ⁴⁾			ROTEX® SP Type GN							ROTEX® SP Type EN							
Size	Spider ¹⁾ (component 2) Rated torque [Nm]	Component cast iron (GJL)	Component SP	Dimensions [mm] ROTEX® SP component 1c						Component SP	Dimensions [mm] ROTEX® SP component 5c						
				max. d ₂ ²⁾	l ₂	DA	G	t	L		max. d ₂ ²⁾	l ₂	l ₃	DA	G	t ₁	L ₁
38	190	1	1c	42	45	87	M8	15	114	5c	28	50	30	87	M8	7	99
		1a							139								124
		1b							139								124
42	265	1	1c	48	50	103	M8	20	126	5c	35	56	34	103	M8	10	110
		1a							151								135
		1b							151								135
48	310	1	1c	55	56	114	M8	20	140	5c	40	60	36	114	M8	10	120
		1a							164								144
		1b							164								144
55	410	1	1c	65	65	130	M10	20	160	5c	45	66	40	130	M10	17	135
		1a							160								135
65	625	1	1c	75	75	146	M10	20	185	5c	55	75	44	146	M10	17	154
		1							185								154

¹⁾ Maximum torque of the coupling $T_{K \max}$ = rated torque of the coupling $T_{K \text{ rated}} \times 2$. Transmittable torque according to 92 ShA.

²⁾ Bores H7 with keyway to DIN 6885 sheet 1 [JS9] and thread for setscrew

³⁾ For dimensions of standard ROTEX® hubs (St) 1, 1a, 1b see catalogue on page 40.

⁴⁾ For dimensions of standard ROTEX® hubs (GJL) 1, 1a, 1b see catalogue on page 38.

■ = Available from stock

Ordering example:	ROTEX® SP 38	GJL	92 ShA	1a	Ø45	1c	Ø42
		Coupling size	Material Components 1, 1a, 1b	Spider hardness	Component	Finish bore	Component

ROTEX® SP ZS-DKM-C

Flexible jaw couplings

Double-cardanic shaft coupling (Non Sparking)

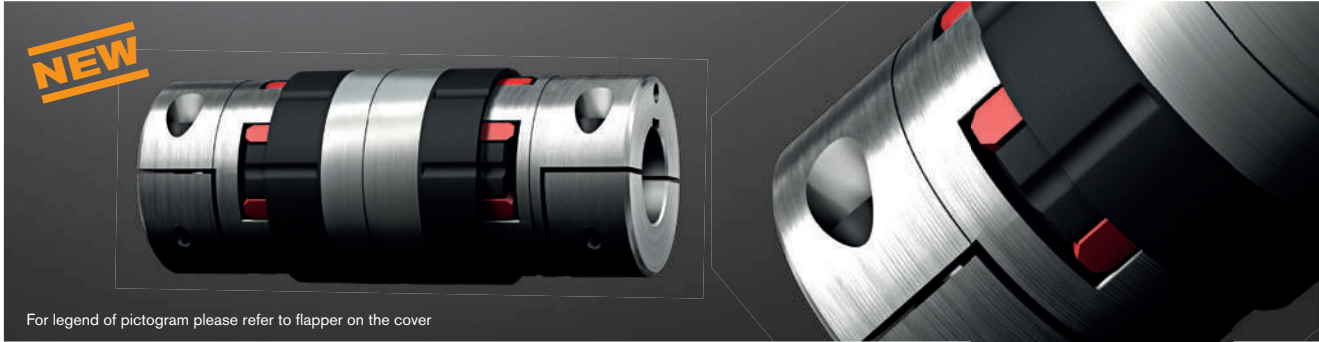

Components

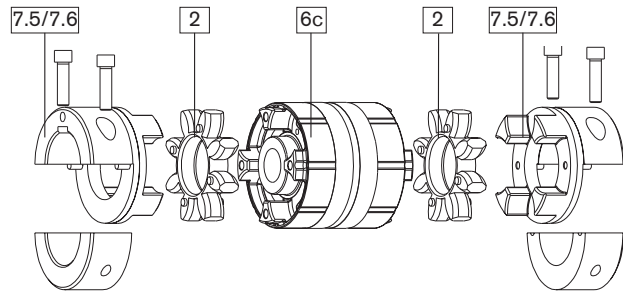
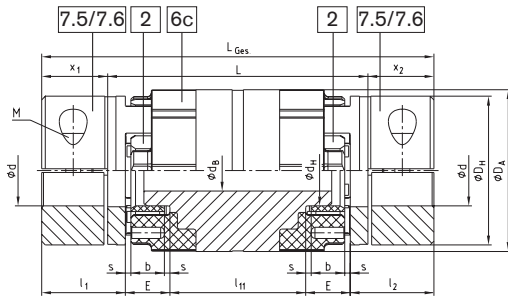

ROTEX® SP Type ZS-DKM-C																
Size	Drop-out center length L	Spider ¹⁾ (component 2) Rated torque [Nm]	Dimensions [mm]												Dimensions [mm]	
			Max. finish bore d ²⁾	L _{total}	General component 7.5/7.6 steel										ROTEX® SP Type 6c Al-H ³⁾	
					l ₁ , l ₂	x ₁ , x ₂	E	b	s	D _H	D _A	d _H	M	T _A [Nm]	d _B	l ₁₁
24	100	35	28	145	30	22.5	18	14	2.0	55	61	27	M6	14	14	49
	185			89												
28	100	95	38	151	35	25.5	20	15	2.5	65	72	30	M8	35	16	41
	191			81												
38	100	190	45	171	45	35.5	24	18	3.0	80	87	38	M8	35	22	33
	211			73												
42	100	265	55	178	50	39	26	20	3.0	95	103	46	M10	69	30	26
	218			66												
48	140	310	60	230	56	45	28	21	3.5	105	114	51	M12	120	35	62
	240			50												
55	180	410	70	280	65	50	30	22	4.0	120	130	60	M12	120	35	90
	200			110												
	300															
65	140	625	80	260	75	60	35	26	4.5	135	146	68	M12	120	48	40
	300			50												

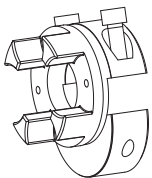

Type 7.5 clamping hub type DH
without feather keyway for double-cardanic connection

Type 7.6 clamping hub type DH
with feather keyway for double-cardanic connection

¹⁾ Maximum torque of the coupling $T_{K \max}$ = rated torque of the coupling $T_{K \text{ rated}}$ x 2. Transmittable torque according to 92 ShA-GS.

²⁾ Hub type 7.5 = without keyway; hub type 7.6 = with keyway acc. to DIN 6685 sheet 1 [JS9]

³⁾ Size 42 with drop-out center length L=100 mm made of steel

■ = Available from stock

Ordering example:	ROTEX® SP 38	ZS-DKM-C	140	98 ShA-GS	7.5	Ø38	7.5	Ø30
	Coupling size	Type	Drop-out center length L	Spider hardness	Hub design	Finish bore	Hub design	Finish bore

ROTEX® ZS-DKM-H

Flexible jaw couplings

Double-cardanic shaft coupling



For legend of pictogram please refer to flapper on the cover

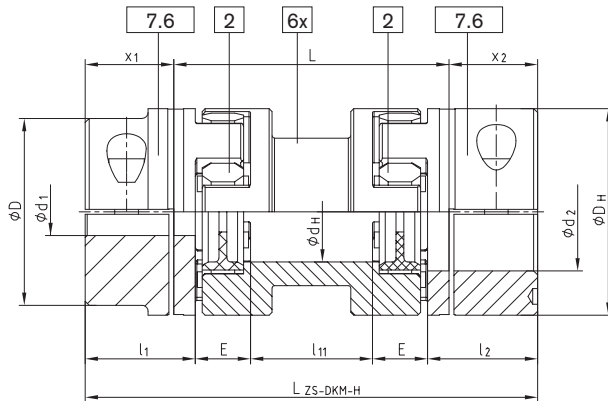

Type ZS-DKM-H

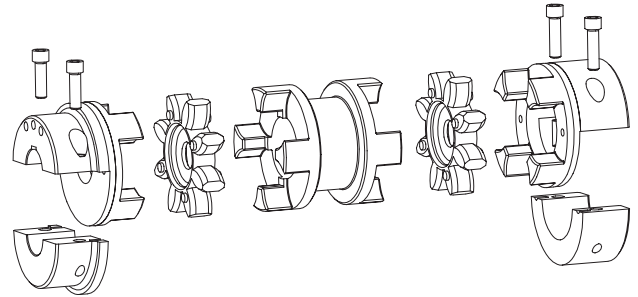

ROTEX® Type ZS-DKM-H																			
Size	Drop-out center length L [mm]	Max. finish bore d ₁ , d ₂	Spider ¹⁾ (component 2) T _{KN} [Nm]	Dimensions [mm]							Screws DIN EN ISO 4762 - 12.9				Max. displacements				Weight ²⁾ [kg]
				DH	dH	l ₁ , l ₂	x ₁ , x ₂	l ₁₁	E	L ZS-DKM-H	M	T _A [Nm]	Axial [mm]	with n = 1500 rpm		with n = 3000 rpm			
														Radial [mm]	Angular [°]	Radial [mm]	Angular [°]		
24	100	28	35	55	27	30	22.5	49	18	145	M6	14	1.4	1.17		0.87		1.40	
	89							185		1.87				1.40					
28	100	38	95	65	30	35	25.5	41	20	151	M8	35	1.5	1.06		0.80		1.90	
	81							191		1.76				1.32		2.20			
38	100	45	190	80	38	45	35.5	33	24	171	M8	35	1.8	0.99		0.74		3.90	
	73							211		1.69				1.27		4.10			
42	100	55	265	95	46	50	39.0	26	26	178	M10	69	2.0	0.91		0.68		5.10	
	66							218		1.60				1.20		5.70			
48	100	60	310	105	51	56	45.0	22	28	190	M12	120	2.1	0.87		0.65		7.10	
	62							230		1.57				1.18		7.90			
55	100	70	410	120	60	65	50.0	10		200	M12	120	2.2	0.70		0.52	0.75	9.50	
	140							240		1.40				1.05		11.20			
	180							280		2.09				1.57		12.30			
	200							300		2.44				1.83		12.80			
65	140	80	625	135	68	75	60.0	40	35	260	M12	120	2.6	1.31		0.98		16.10	
	80							300		2.00				1.50		16.80			
75	140							25		275				1.13		0.85		23.60	
	180							315		1.83				1.37		26.00			
	200							335		2.19				1.64		27.00			
	250							385		3.05				2.29		29.50			
90	180	110	2400	200	100	100	81.5	53	45	343	M20	580	3.4	1.71		1.28		48.90	
	123							413		2.93				2.19		52.60			
100	250	110	3300	225	105	110	84	98	50	418	M20	580	3.4	2.6	-	-	60		
110	250	120	4800	255	115	120	88	76	55	426	M20	580	3.4	2.3	-	-	90		
125	250	140	6650	290	133	140	105	60	60	460	M24	1000	3.4	1.6	-	-	120		

¹⁾ Maximum torque of the coupling T_{K max} = rated torque of the coupling T_{K rated} x 2.
Size 24 to 90 spider type 98 ShA-GS / transmittable torque acc. to 92 ShA-GS.

7.6 = Shell clamping hub with feather key for a double-cardanic connection
ATTENTION: The standard series can be used with horizontal mounting only. Vertical assembly on request.

Ordering example:	ROTEX® 38	ZS-DKM-H	140	98 ShA-GS	7.6	Ø 38	7.6	Ø30
	Coupling size	Type	Shaft distance dimension L	Spider hardness	Hub design	Finish bore	Hub design	Finish bore

ROTEX® DKM

Flexible jaw couplings

Double-cardanic shaft coupling

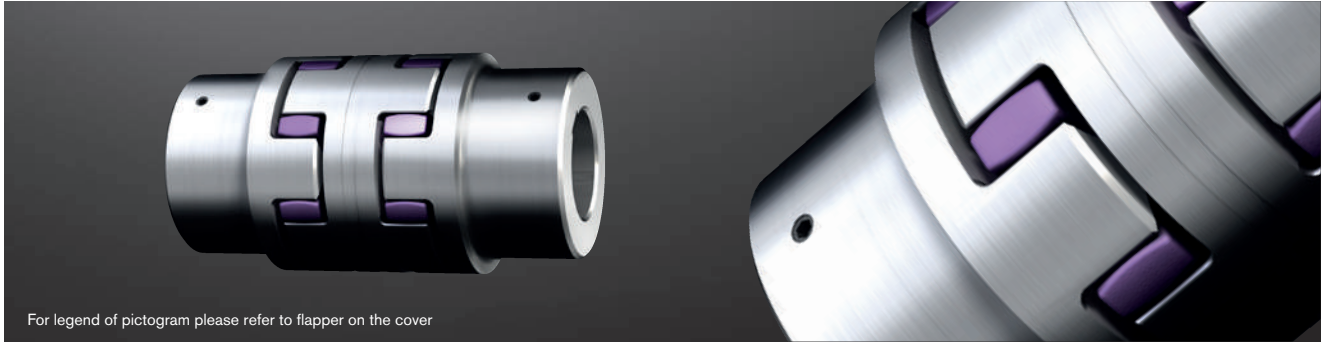

For legend of pictogram please refer to flapper on the cover

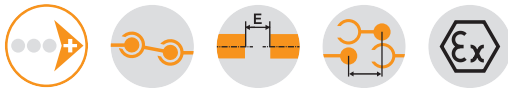

Components

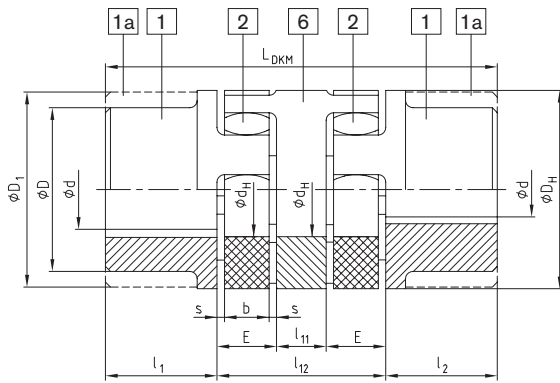

Type DKM

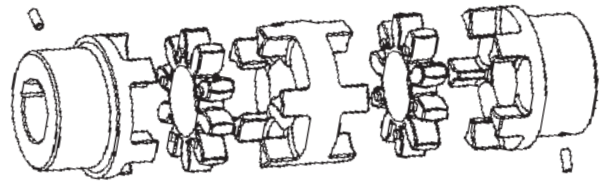

ROTEX® Type DKM																
Size	d, D, D ₁	Spider ¹⁾ (component 2)		Dimensions [mm]									Max. displacements with n = 1500 rpm			
		Rated torque [Nm]		D _H	d _H	l _{1,2}	l ₁₁	l ₁₂	E	s	b	L _{DKM}	Radial [mm]	Angular [°]	Axial [mm]	
19	See jaw couplings on page 34 to 36 For stock programme / basic programme see page 32 and 33	92 ShA	98 ShA	40	18	25	10	42	16	2.0	12	92	0.45	1.0	+1.2/-1.0	
24		35	60	55	27	30	16	52	18	2.0	14	112	0.59	1.0	+1.4/-1.0	
28		95	160	65	30	35	18	58	20	2.5	15	128	0.66	1.0	+1.5/-1.4	
38		190	325	80	38	45	20	68	24	3.0	18	158	0.77	1.0	+1.8/-1.4	
42		265	450	95	46	50	22	74	26	3.0	20	174	0.84	1.0	+2.0/-2.0	
48		310	525	105	51	56	24	80	28	3.5	21	192	0.91	1.0	+2.1/-2.0	
55		410	685	120	60	65	28	88	30	4.0	22	218	1.01	1.0	+2.2/-2.0	
65		625	940	135	68	75	32	102	35	4.5	26	252	1.17	1.0	+2.6/-2.0	
75		1280	1920	160	80	85	36	116	40	5.0	30	286	1.33	1.0	+3.0/-3.0	
90		2400	3600	200	100	100	40	130	45	5.5	34	330	1.48	1.0	+3.4/-3.0	

¹⁾ For selection see page 14 et seqq.
Finish bore according to ISO fit H7, feather keyway according to DIN 6885, sheet 1 [JS9].

Ordering example:	ROTEX® 38	DKM	GJL	98 ShA	1	Ø38	1	Ø30
	Coupling size	Type	Material	Spider hardness	Component	Finish bore	Component	Finish bore

ROTEX® CF, CFN, DF and DFN Flexible jaw couplings

Flange programme

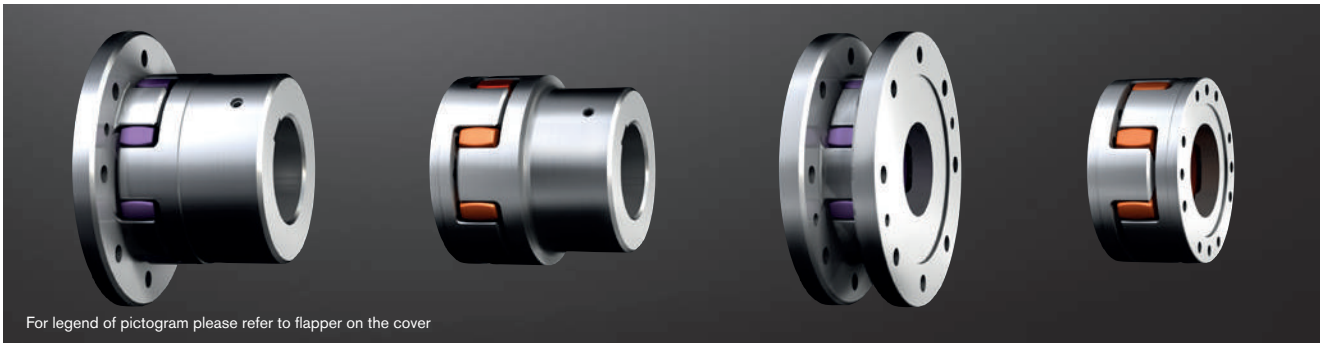

For legend of pictogram please refer to flapper on the cover



Components

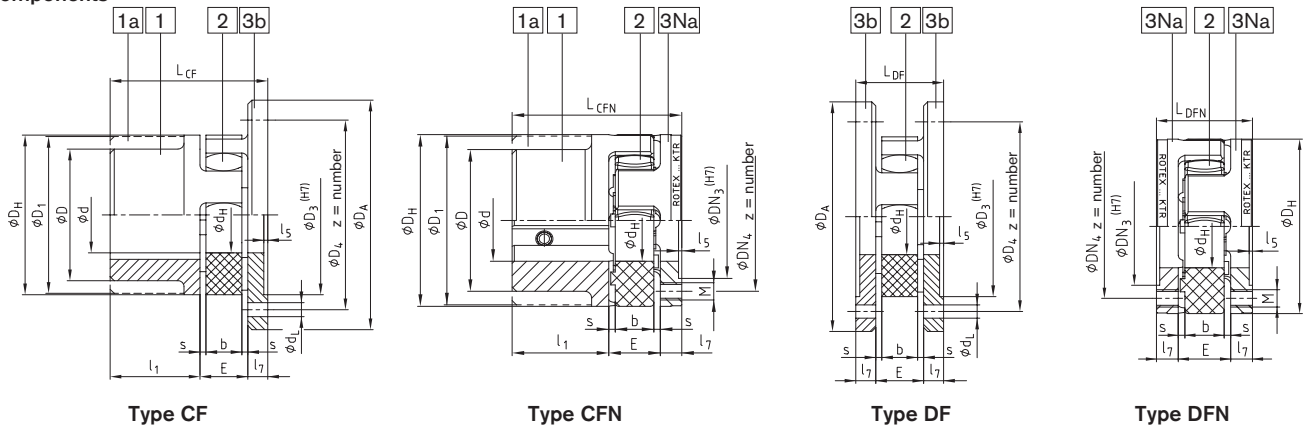

ROTEX® Type CF, CFN and DF, DFN																							
Size	d, D, D ₁	Dimensions general [mm]							Dimensions CF and DF [mm]							Dimensions CFN and DFN [mm]							
		D _H	d _H	l ₁	E	s	b	l ₅	l ₇	D _A	D ₃	D ₄	z	d _L	L _{CF}	L _{DF}	DN ₃	DN ₄	M	z	Pitch	L _{CFN}	L _{DFN}
24		55	27	30	18	2.0	14	1.5	8	80	55	65	5	4.5	56	34	36	45	M5	8		56	34
28		65	30	35	20	2.5	15	1.5	10	100	65	80	6	6.6	65	40	44	54	M6	8	8x45°	65	40
38		80	38	45	24	3.0	18	1.5	10	115	80	95	6	6.6	79	44	54	66	M8	8		79	44
42		95	46	50	26	3.0	20	2.0	12	140	95	115	6	9.0	88	50	65	80	M8	12	16x22.5°	88	50
48		105	51	56	28	3.5	21	2.0	12	150	105	125	8	9.0	96	52	75	90	M8	12		96	52
55		120	60	65	30	4.0	22	2.0	16	175	120	145	8	11.0	111	62	84	102	M10	8	8x45°	111	62
65		135	68	75	35	4.5	26	2.0	16	190	135	160	10	11.0	126	67	96	116	M10	12	16x22.5°	126	67
75		160	80	85	40	5.0	30	2.5	19	215	160	185	10	13.5	144	78	112	136	M12	15		144	78
90		200	100	100	45	5.5	34	3.0	20	260	200	225	12	13.5	165	85	145	172	M16	15		165	85
100		225	113	110	50	6.0	38	4.0	25	285	225	250	12	13.5	185	100	165	195	M16	15		185	100
110		255	127	120	55	6.5	42	4.0	26	330	255	290	12	18.0	201	107	180	218	M20	15	20x18°	201	107
125		290	147	140	60	7.0	46	5.0	30	370	290	325	16	18.0	230	120	215	252	M20	15		230	120
140		320	165	155	65	7.5	50	5.0	34	410	320	360	16	22.0	254	133	245	282	M20	15		254	133
160		370	190	175	75	9.0	57	5.0	38	460	370	410	16	22.0	288	151	280	325	M24	15		288	151
180		420	220	195	85	10.5	64	5.5	40	520	420	465	16	26.0	320	165	330	375	M24	18	24x15°	320	165

For other flange programmes see page 45.

Other types: ROTEX® CF-H
Flange drop-out center design coupling
Please order our separate dimension sheet
(M412069).

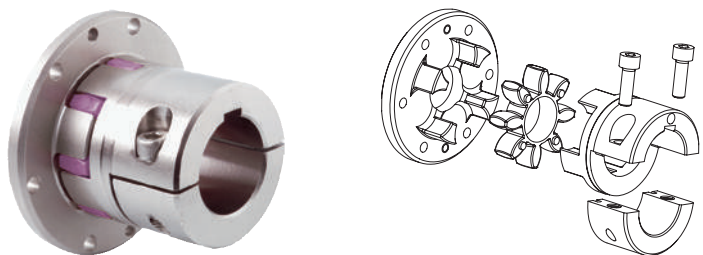

Ordering example:	ROTEX® 38	CF	92 ShA	1	GJL	Ø20
	Coupling size	Type	Spider hardness	Hub side, component	Material	Finish bore

ROTEX® ZR

Flexible jaw couplings

Intermediate shaft programme

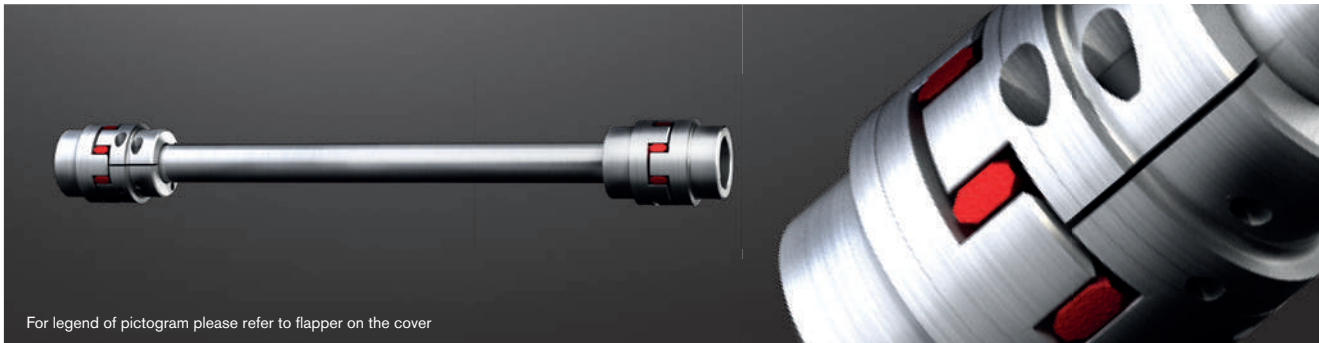

For legend of pictogram please refer to flapper on the cover

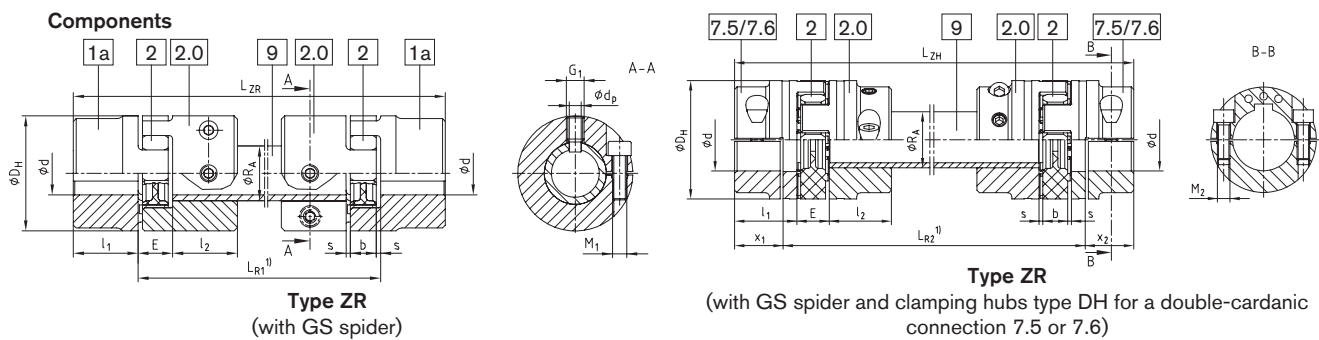

ROTEX® Type ZR																					
Size	Max. finish bore d		Dimensions [mm]						Intermediate pipe Torsional stiffness/m		Clamping screw component 2.0		Clamping screw component 7.5/7.6		LZR, LZH	min. LZR1	min. LZR2	Locking screw G1	Cone bore dp [mm]	Axial displacement [mm]	Angular displacement [degree]
	Component 1a	Component 7.5/7.6	DH	l1, l2	x1, x2	E	s	b	RA	C ²⁾ [Nm ² /rad]	M1	TA [Nm]	M2	TA [Nm]							
19	25	20	40	25	17.5	16	2.0	12	Ø20x3	954.9	M6	14	M6	10	LZR1 + 2 • l1 LZR2 + 2 • x1/2	110	97	M6	4.0	1.2	0.9
24	35	28	55	30	22.5	18	2.0	14	Ø30x4	4522	M6	14	M6	14		128	111	M8	5.5	1.4	0.9
28	40	38	65	35	25.5	20	2.5	15	Ø35x4	7611	M8	35	M8	35		145	129	M10	7.0	1.5	0.9
38	48	45	80	45	35.5	24	3.0	18	Ø40x4	11870	M8	25	M8	35		180	157	M12	8.5	1.8	1.0
42	55	55	95	50	39.0	26	3.0	20	Ø45x4	17487	M10	49	M10	69		198	174	M12	8.5	2.0	1.0
48	62	60	105	56	45.0	28	3.5	21	Ø50x4	24648	M12	86	M12	120		217	190	M16	12	2.1	1.1
55	74	70	120	65	50.0	30	4.0	22	Ø55x4	33544	M12	120	M12	120		242	220	M16	12	2.2	1.1
65	80	80	135	75	60.0	35	4.5	26	Ø65x5	68329	M12	120	M12	120	281	250	M16	12	2.6	1.2	
75	95	90	160	85	67.5	40	4.0	30	Ø75x5	108000	M16	295	M16	295	318	285	M16	12	3.0	1.2	

¹⁾ For inquiries and orders please specify the shaft distance dimension LZR1/LZR2 along with the maximum speed to review the critical bending speed.
²⁾ Torsion spring stiffness with an intermediate pipe having a length of 1 m
 Finish bore according to ISO fit H7, feather keyway according to DIN 6885, sheet 1 [JS9].
 Friction torques of clamping hubs have to be considered.
 Please order dimension sheet M 583613.

Not permissible for crane and hoist drives

Diagramme for coupling selection:

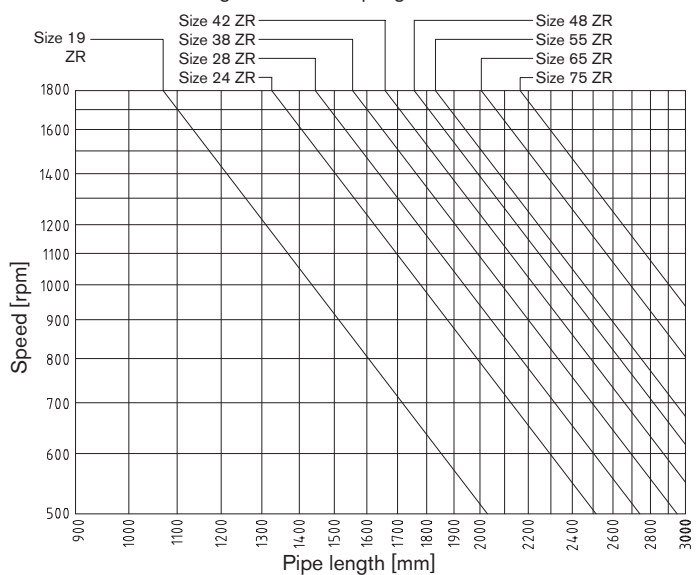

Ordering example:	ROTEX® 38	ZR	1200	98 ShA-GS	7.5	Ø38	7.5	Ø30
	Coupling size	Type	Shaft distance dimension LZR1/LZR2	Spider hardness	Hub design	Finish bore	Hub design	Finish bore

ROTEX® BTAN and SBAN Flexible jaw couplings

With brake drum/with brake disk

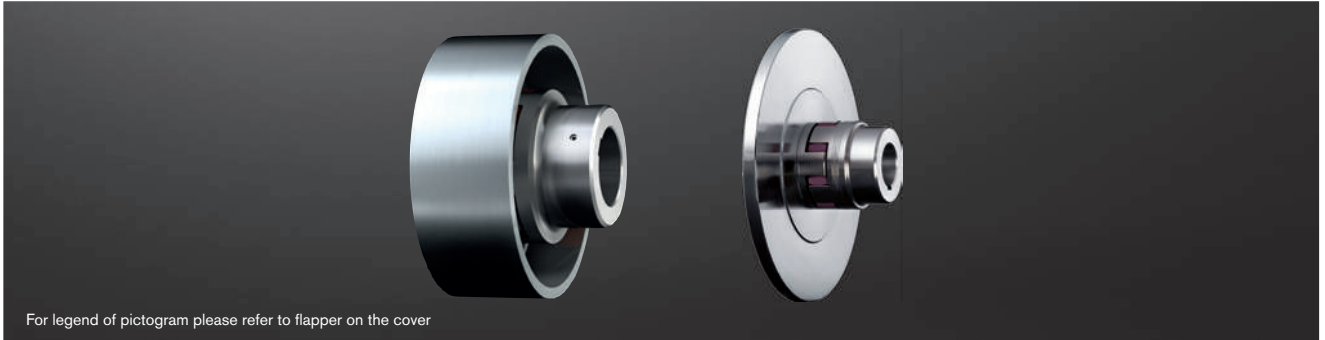

For legend of pictogram please refer to flapper on the cover



ROTEX® Type BTAN and SBAN

Size	Pilot bore, d, D, D ₁	Max. finish bore d ₁		Dimensions [mm]										
		GJS	Steel	D _H	D ₂	D ₄	d _H	z	pitch ¹⁾	M	T _A [Nm]	l _{1, 2}	E	L
38	See jaw couplings on page 34 to 36 For stock programme / basic programme see page 32 and 33	—	35	80	50	66	38	8	8 x 45°	M8	35	45	24	114
42		—	45	95	60	80	46	12	16 x 22.5°	M8	41	50	26	126
48		—	50	105	68	90	51	12		M8	41	56	28	140
55		—	58	120	78	102	60	8	8 x 45°	M10	83	65	30	160
65		—	68	135	92	116	68	12	16 x 22.5°	M10	83	75	35	185
75		—	78	160	106	136	80	15		M12	120	85	40	210
90		—	100	200	140	172	100	15		M16	295	100	45	245
100		100	—	225	156	195	113	15	20 x 18°	M16	295	110	50	270
110		110	—	255	176	218	127	15		M20	580	120	55	295
125		130	—	290	204	252	147	15		M20	580	140	60	340

Brake drum	Type BTAN										Speed rpm [V] (30 m/s)	Brake disk	Type SBAN										Speed rpm [V] (30 m/s)
	ROTEX® BTAN dimension „C“												ROTEX® dimension „N“										
	38	42	48	55	65	75	90	100	110	125		38	42	48	55	65	75	90	100	110	125		
160x60	14										3550	200x12.5	31.25										2800
200x75	9	12	17	24							2800	250x12.5	31.25	34.25	39.25								2240
250x95	1	4	9	16	25	33					2240	315x16		32.5	37.5	44.5	53.5	61.5					1800
315x118		-5	0	7	16	24	36				1800	400x16			37.5	44.5	53.5	61.5	73.5	81.5	88.5		1400
400x150		-18	-13	-6	3	11	23	31	38		1400	500x16				44.5	53.5	61.5	73.5	81.5	88.5	104.5	1120
500x190						-12	-4	8	16	23	39	1120	630x20				51.5	59.5	71.5	79.5	86.5	102.5	900
630x236							-22	-10	-2	5	21	900	710x20				51.5	59.5	71.5	79.5	86.5	102.5	800
710x265									-13	-6	10	800	800x25						69	77	84	100	710
800x300										-4	710	900x25									84	100	630

¹⁾ Thread in the hub between the cams.

Other sizes on request according to dimension sheet:

BTAN: M380821

SBAN straight: M380822; cranked: M 370065

FNN hub: M 380823

Finish bore according to ISO fit H7, feather keyway according to DIN 6885, sheet 1 [JS9].

Ordering example:

ROTEX® 38	BTAN	Ø200x75	98 ShA	1Nd	Ø34	1	Ø30
Coupling size	Type	Brake drum Ø x width	Spider hardness	Component	Finish bore	Component	Finish bore

Components

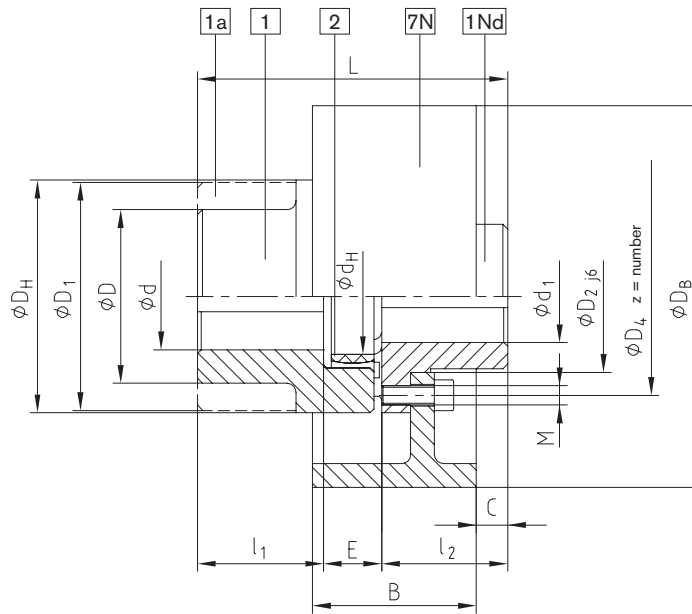

Brake drum
Type BTAN

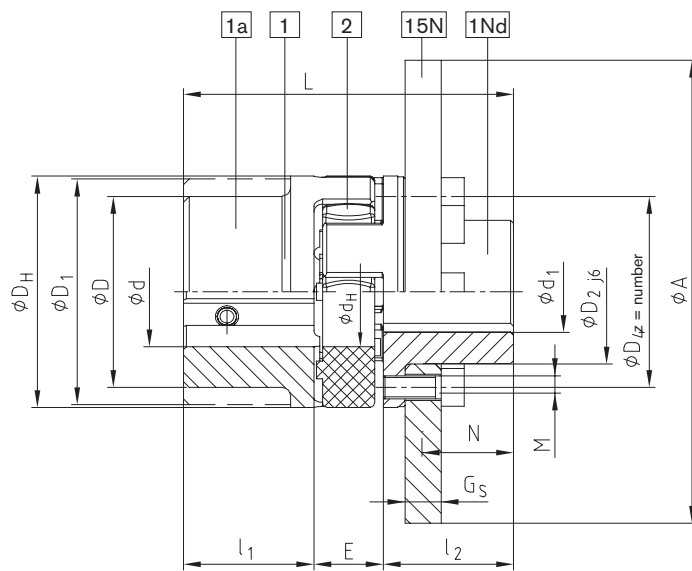

Brake disk
Type SBAN

ROTEX®

POLY-NORM®

POLY

REVOLEX®

Flexible jaw and
pin & bush couplings

ROTEX® AFN-SB special Flexible jaw couplings

Drop-out center design coupling with brake disk



For legend of pictogram please refer to flapper on the cover

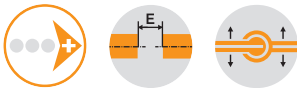

Components

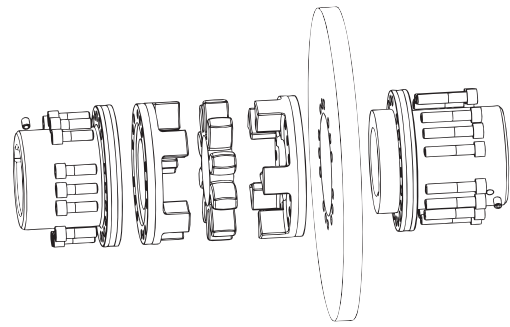
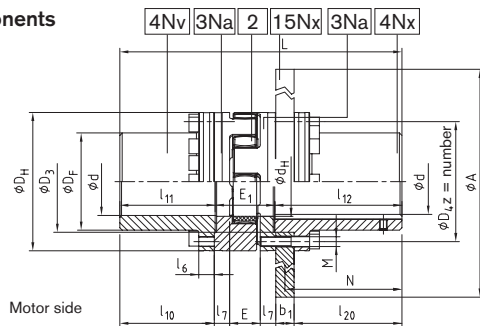

ROTEX® Type AFN-SB special

Size	Finish bore d		Dimensions [mm]										
	Min.	Max.	D _H	D _F	D ₃ H7/h7	D ₄	d _H	E	E ₁	M	z	Pitch	T _A [Nm]
65	22	70	135	94	96	116	68	35	65	M10	12	16x22.5°	83
75	30	80	160	108	112	136	80	40	75	M12	15		120
90	40	105	200	142	145	172	100	45	82	M16	15		295
100	46	115	225	158	165	195	113	50	97	M16	15		295
110	60	130	255	178	180	218	127	55	103	M20	15	20x18°	580
125	60	150	290	206	215	252	147	60	116	M20	15		580
140	60	170	320	235	245	282	165	65	128	M20	15		580
160	80	200	370	270	280	325	190	75	146	M24	15		1000
180	85	230	420	315	330	375	220	85	159	M24	18	24x15°	1000

ROTEX® Type AFN-SB special

Size	Torque with 98 ShA ¹⁾		Max. speed [rpm]	Max. braking torque ²⁾ [Nm]	Dimensions [mm]						
	T _{KN}	T _{K max}			l ₇	l ₁₀	l ₁₁	l ₁₂	l ₂₀	N	L
65	940	1880	3450	1880	16	112.5	113.5	166.0	135	150	344.5
75	1920	3840	3250	3840	19	131.5	133.0	166.5	135	150	374.5
90	3600	7200	3000	7200	20	164.0	165.5	206.5	175	190	454.0
100	4950	9900	2800	9900	25	153.5	155.0	206.5	175	190	458.5
110	7200	14400	2600	14400	26	201.5	203.5	212.0	180	195	518.5
125	10000	20000	2250	20000	30	198.5	200.5	212.0	180	195	528.5
140	12800	25600	1800	25600	34	244.5	247.0	252.5	220	235	627.5
									210 ³⁾	230 ³⁾	
160	19200	38400	1500	38400	38	226.5	229.0	252.5	220	235	627.5
									210 ³⁾	230 ³⁾	
180	28000	56000	1350	56000	40	195.0	198.0	252.5	220	235	609.5

ROTEX® Selection of coupling/brake disk

Size	Brake disk ØA x b ₁										
	355x30	400x30	450x30	500x30	560x30	630x30	710x30	800x30	900x30	900x40	1000x40
65	x	x	x								
75		x	x	x							
90			x	x	x	x					
100				x	x	x					
110				x	x	x	x				
125						x	x	x			
140							x	x	x	x	x
160							x	x	x	x	x
180							x	x	x	x	x

¹⁾ For selection see page 14 et seqq. ²⁾ The maximum braking torque must not exceed the maximum torque of the coupling. ³⁾ Dimensions with a width of brake disk b₁ of 40 mm.

Ordering example:

ROTEX® 90	AFN-SB special	Ø450x30	98 ShA	4Nv	Ø90	4Nx	Ø90
Coupling size	Type	Brake disk Ø x width	Spider hardness	Component	Finish bore	Component	Finish bore

ROTEX® SD

Flexible jaw-type couplings

Shiftable coupling shiftable at standstill

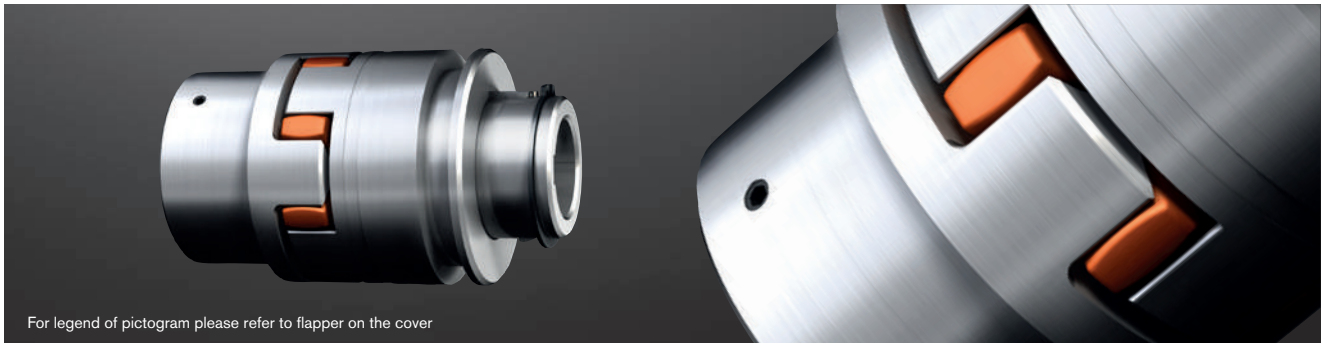

For legend of pictogram please refer to flapper on the cover



Components

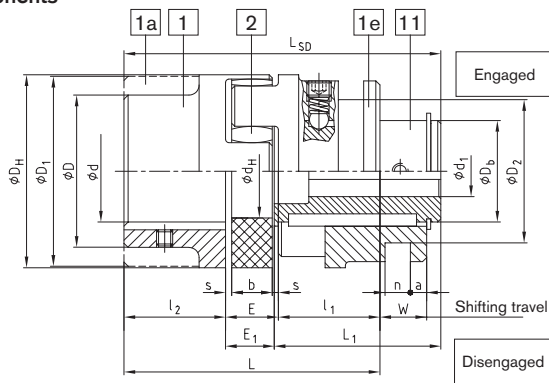

Type SD

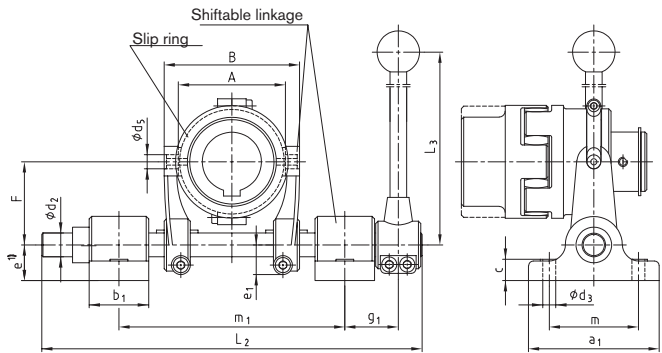

Type SD with slip ring and shiftable linkage

ROTEX® Type SD																						
Size	d, D, D1	Finish bore d1		Dimensions [mm]																Shifting force set in [N]	Slip ring size	Shiftable linkage size
		Min.	Max.	DH	D2±0,1	Db	dH	l1, l2	E	s	b	E1	L	L1	W	a	n ±0,1	LSD				
24	See jaw couplings on page 34 to 36 For stock programme / basic programme see page 32 and 33	8	20	55	41	30	27	30	18	2.0	14	16.5	78	51.5	16.0	6	6.0	98	110	—	—	
28		10	24	65	58	36	30	35	20	2.5	15	18.0	90	60.0	17.5	8	8.0	113	130	—	—	
38		12	30	80	70.5	45	38	45	24	3.0	18	22.0	114	73.0	21.0	8	12.5	140	150	1.1	1	
42		14	35	95	70.5	50	46	50	26	3.0	20	24.0	126	82.0	23.0	8	12.5	156	180	1.1	1	
48		15	42	105	89.5	60	51	56	28	3.5	21	25.5	140	90.5	24.5	6	17.5	172	200	2.2	2	
55		18	50	120	112.5	70	60	65	30	4.0	22	27.0	160	103.0	26.0	6	18.0	195	250	3.3	3	
65		20	55	135	112.5	80	68	75	35	4.5	26	32.0	185	120.0	30.5	7	18.0	227	280	3.3	3	
75		25	65	160	130.5	95	80	85	40	5.0	30	37.0	210	135.0	35.0	6	20.5	257	350	4.4	3	
90		28	75	200	164.5	110	100	100	45	5.5	34	41.0	245	152.0	39.5	8	25.5	293	350	5.5	4	
100		30	80	225	164.5	115	113	110	50	6.0	38	46.0	270	169.0	44.0	14	25.5	325	380	5.5	4	
110		35	85	255	164.5	125	127	120	55	6.5	42	51.5	295	184.0	48.5	18.5	25.5	355	450	5.5	4	
125		40	100	290	210.5	145	147	140	60	7.0	46	55.5	340	208.5	53.0	18.5	30.5	404	500	6.6	5	

Slip ring and shiftable linkage																				
Size	Size of shiftable linkage	Dimensions [mm]																Max. speed [rpm] for slip ring		
		a1	b1	c	d2	d3	d5	e ¹⁾	e1	F	g1	L2	L3	m	m1 min.	m1 max.	A		B	
38	1																			
42	1	110	50	18	20	11	12	30	25	70	55	320	400	75	180	190	90	114		3280
48	2				25				27	97.5	60	430	450		240	270	111	151		2550
55	3	140					17	40	32.5	120	70	490	600	100			140	180		2120
65	3				30															
75	3		60	25		13.5											170	210		1710
90	4																			
100	4	160			35		21	50	37.5	147.5	70	565	750	120	321	365	200	244		1360
110	4																			
125	5				40		25		46	190	80	630	1085		365	410	250	300		855

¹⁾ With a through base plate dimension „e“ of the shiftable linkage size 5 has to be increased by at least 10 mm. Finish bore according to ISO fit H7, feather keyway according to DIN 6885, sheet 1 [JS9].

Ordering example:	ROTEX® 38	SD	With 1.1 and 1	98 ShA	1	Ø38	11	Ø28
	Coupling size	Type	with slip ring 1.1 and shiftable linkage 1	Spider hardness	Component	Finish bore	Component	Finish bore

ROTEX® FNN

Flexible jaw couplings

For mounting of fan

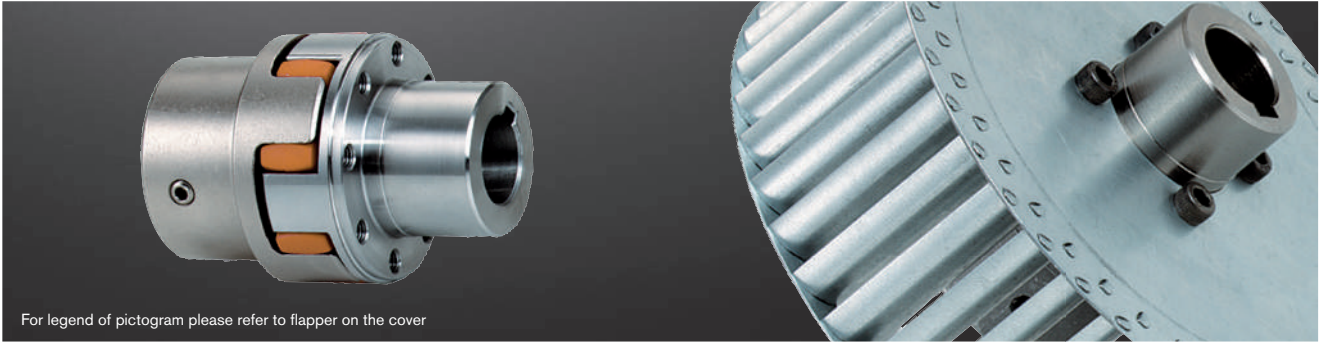

For legend of pictogram please refer to flapper on the cover



Components

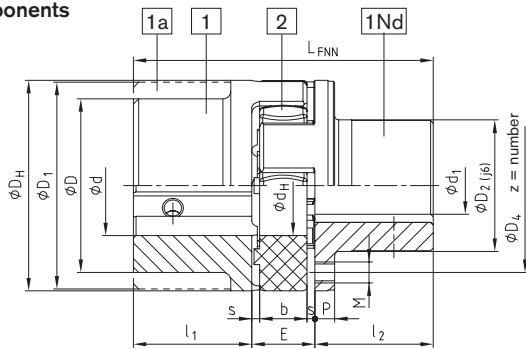

Type FNN

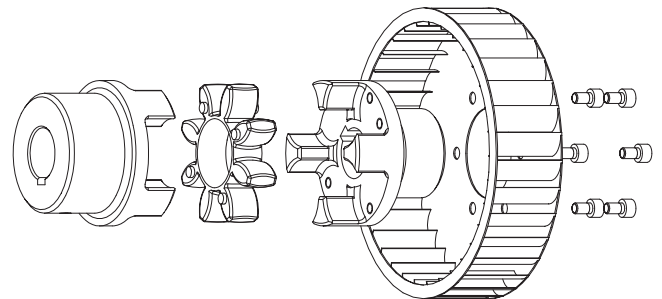

Type FNN with fan (type 1)

ROTEX® Type FNN															
Size	d, D, D ₁	Max. finish bore d ₁	Dimensions [mm]												
			D _H	D ₂	D ₄	d _H	E	s	b	l ₁ , l ₂	P	M	z	Pitch	LFNN
28	See jaw couplings on page 34 to 36 For stock programme / basic programme see page 32 and 33	28	65	40	54	30	20	2.5	15	35	6.5	M6	8	8x45°	90
38		35	80	50	66	38	24	3.0	18	45	7.5	M8	8		114
42		42	95	60	80	46	26	3.0	20	50	9.5	M8	12		126
48		50	105	68	90	51	28	3.5	21	56	10.5	M8	12	16x22.5°	140
55		55	120	78	102	60	30	4.0	22	65	12.5	M10	8	8x45°	160
65		65	135	92	116	68	35	4.5	26	75	13.5	M10	12	16x22.5°	185
75		75	160	106	136	80	40	5.0	30	85	15.5	M12	15	20x18°	210
90		100	200	140	172	100	45	5.5	34	100	18.5	M16	15		245

Other sizes on request.

Type 1: Fan screwed on

The ROTEX® hub can be supplied with the fan screwed on. Customized connection dimensions such as pitch circle of threads, size of threads and number or centering of fans must be specified in your inquiry.



Type 2: Fan injection-moulded

Low prices due to optimisation of production with bigger volumes.

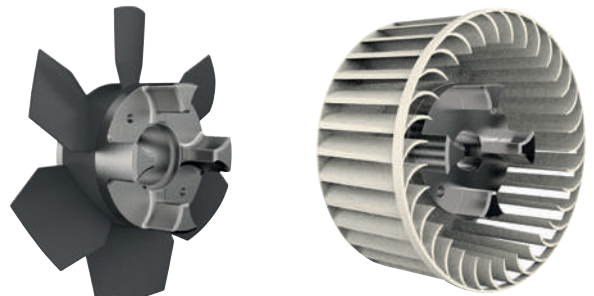

Ordering example:

ROTEX® 38	FNN	92 ShA	1	Ø38	1Nd	Ø30
Coupling size	Type	Spider hardness	Component	Finish bore	Component	Finish bore

Other types with clamping sets

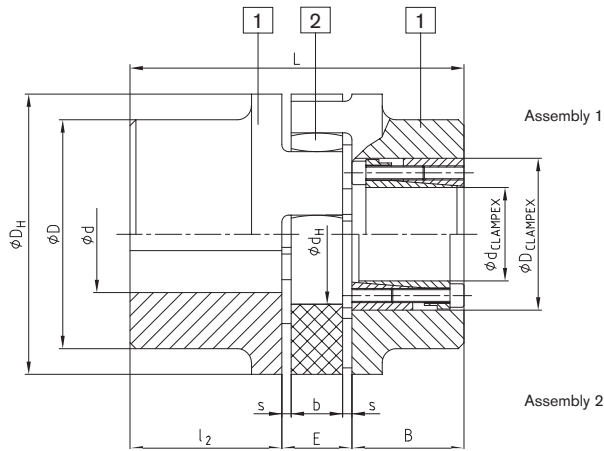

Components

ROTEX® with clamping set CLAMPEX® KTR 200																
Size	d, D, D ₁	Hub material	CLAMPEX® KTR 200				Dimensions [mm]									
			Max. size of KTR clamping set dxD	Transmittable torque and axial force		B	l ₂	E	s	b	D _H	D	d _H	L		
				T [Nm]	F _{AX} [kN]											
42	See jaw couplings on page 34 to 36 For stock programme / basic programme see page 32 and 33	Steel Component 1	30x55	790	53	48	50	26	3.0	20	95	—	46	(clamping set)		
48			35x60	1300	74	48	56	28	3.5	21	105	—	51			
55			45x75	2200	98	59	65	30	4.0	22	120	—	60			
65			45x75	2200	98	59	75	35	4.5	26	135	115	68			
75			50x80	3330	132	59	85	40	5.0	30	160	135	80			
90			65x95	4300	132	59	100	45	5.5	34	200	160	100			
100		65x95	4300	132	59	110	50	6.0	38	225	180	113	l ₂ + E + B			
110		70x110	7500	214	70	120	55	6.5	42	255	200	127				
125		80x120	8500	213	70	140	60	7.0	46	290	230	147	Length = l ₂ + E + B			
140		95x135	12600	265	70	155	65	7.5	50	320	255	165				
160		110x155	16500	300	80	175	75	9.0	57	370	290	190				
180		120x165	22500	375	80	195	85	10.5	64	420	325	220				

Type 4.2 with CLAMPEX® clamping set KTR 250

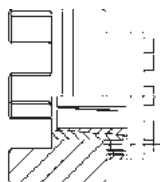

Frictionally engaged, backlash-free shaft-hub-connection for transmitting average torques.

Type 4.3 with CLAMPEX® clamping set KTR 400

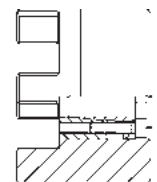

Frictionally engaged, backlash-free shaft-hub-connection for transmitting bigger torques. Maximum size of clamping set depends on the hub collar diameter. Clamping set screw fitting possible both internally and externally. For details of calculation see CLAMPEX® catalogue.

For CLAMPEX® programme see page 280 to 313.

Other types with torque limiters

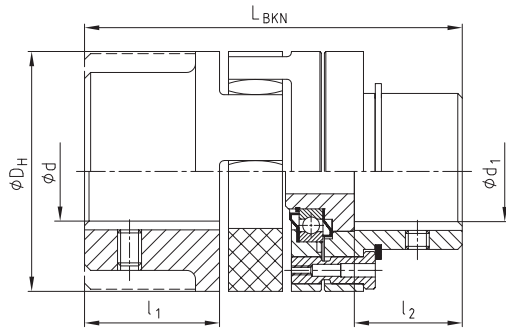

ROTEX® BKN - Shear pin coupling, type BKN							
Size	Max. finish bore d	Max. finish bore d ₁	l ₁	l ₂	L _{BKN}	D _H	Min. fracture torque [Nm]
28	See jaw couplings on page 34 to 36 Stock programme/basic programme on page 32 and 33	28	35	25	101	65	100
38		38	45	35	125	80	190
42		42	50	40	139	95	250
48		48	56	46	153	105	300
55		55	65	55	177	120	400
65		65	75	65	202	135	500
75		75	85	70	230	160	600
90		100	100	85	266	200	700

Customer variant from the stock programme.
Please specify the fracture torques with your order!
For further details see dimension sheet No. 5020/000/009-760313

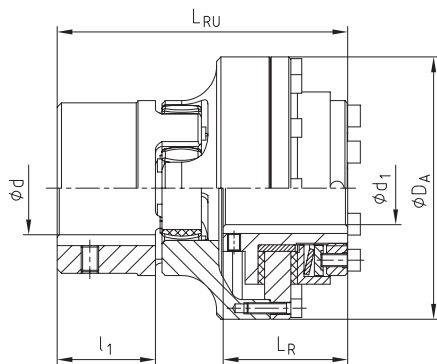

ROTEX® - RUFLEX® - Overload coupling									
ROTEX® size	RUFLEX® size	Ratchet torques [Nm]	d	d ₁ max.	D _A	l ₁	L _R	L _{RU}	
14	00	0.5 - 5	See jaw couplings on page 34 to 36; stock programme/basic programme on page 32 and 33	10	44	11	31	59	
19	0	2 - 20		20 ¹⁾	63	25	33	78	
24	01	5 - 70		22	80	30	45	98	
28	1	20 - 200		25	98	35	52	113	
38	2	25 - 400		35	120	45	57	133	
48	3	50 - 800		45	162	56	68	166	
75	4	90 - 1600		55	185	85	78	205	

¹⁾ Finish bore exceeding Ø19, feather keyway according to DIN 6885 sheet 3

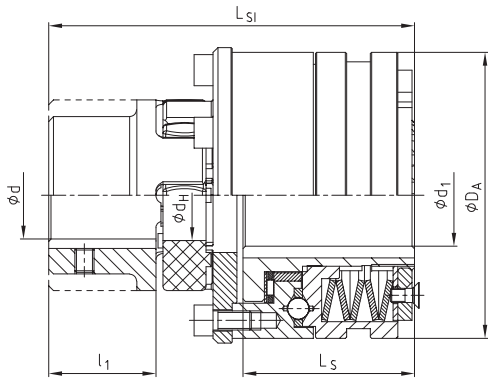

ROTEX® - KTR-SI - Overload coupling									
ROTEX® size	KTR-SI type	KTR-SI size	Ratchet torques [Nm]	d	Max. d ₁	D _A	l ₁	L _S	L _{SI}
28	DK	2	12-200	See jaw couplings on page 34 to 36 Stock programme/basic programme on page 32 and 33	35	100	35	56	124
	SR/SGR	0	5-40		20	55		34.5	102
38	DK	3	25-450		45	120	45	73	155
	SR/SGR	1	12-100		25	82	48	129.5	
48	DK	4	50-1000		55	146	56	93.5	194
	SR/SGR	2	25-200		35	100	56	155	
55	DK	5	85-2000		65	176	65	107	222.5
	SR/SGR	3	50-450		45	120	73	186	
75	DK	—	—		—	—	—	—	—
	SR/SGR	4	100-2000	55	146	85	93.5	241.5	
90	DK	—	—	—	—	—	—	—	
	SR/SGR	5	170-3400	65	176	100	107	275.5	

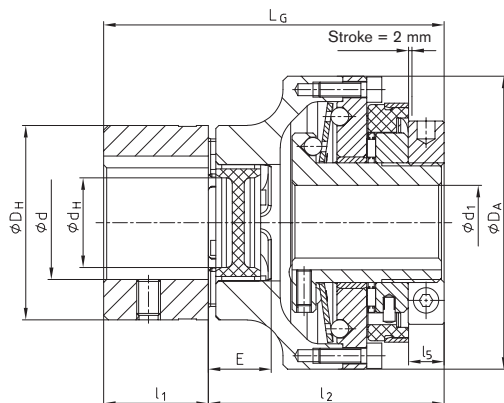

SYNTAX® - Backlash-free, torsionally rigid overload coupling with ROTEX® GS																
ROTEX® size	SYNTAX® size	SYNTAX® torque range disk spring [Nm]				Max. bore		D _A	D _H	d _H	E	L	L _G	l ₁	l ₂	l ₅
		DK ₁	DK ₂	SK ₁	SK ₂	d	d ₁									
24	20	6-20	15-30	10-20	20-65	35	20	80	55	27	18	45	100	30	70	10
28	25	20-60	45-90	25-65	40-100	40	25	98	65	30	20	50	113	35	78	11
38	35	25-80	75-150	30-100	70-180	48	35	120	80	38	24	60	136	45	91	13
48	50	60-180	175-300	80-280	160-400	55	50	162	105	51	28	70	167	56	111	14

ROTEX® Flexible jaw couplings

Weights and mass moments of inertia

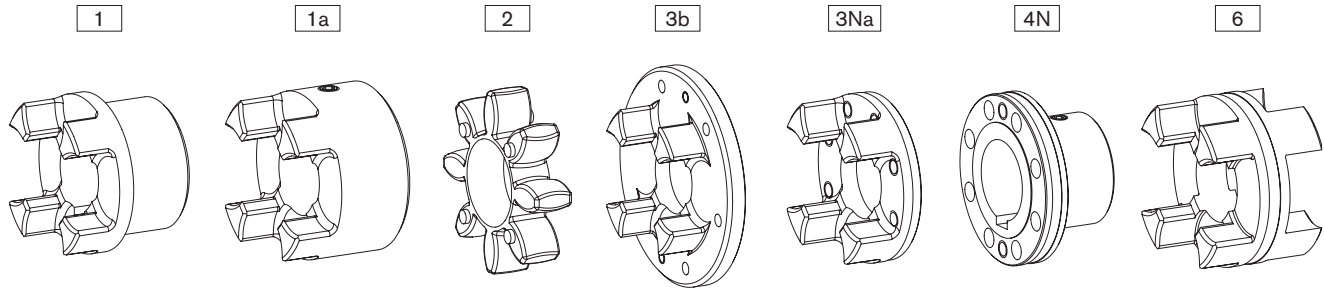

ROTEX® individual components														
Size	Standard hub				Large hub			Spider	Driving flange				Coupling flange	DKM spacer
	Component 1				Component 1a			Component 2	Component 3b	Component 3Na			Component 4N	Component 6
	Alu [kg] [kgm²]	GJL [kg] [kgm²]	GJS [kg] [kgm²]	St [kg] [kgm²]	Alu [kg] [kgm²]	GJL [kg] [kgm²]	St [kg] [kgm²]	Polyurethane (Vulkollan) [kg] [kgm²]	GJS [kg] [kgm²]	St [kg] [kgm²]	GJS [kg] [kgm²]	St [kg] [kgm²]	Alu [kg] [kgm²]	
14	—	—	—	—	0.020	—	—	0.0044	—	—	—	—	—	
	—	—	—	—	0.000003	—	—	0.0000005	—	—	—	—	—	
19	0.064	—	—	—	0.074	—	0.25	0.0057	—	—	—	—	—	
	0.00001	—	—	—	0.00002	—	0.00006	0.000001	—	—	—	—	—	
24	0.123	—	—	—	0.174	—	0.55	0.014	0.028	0.145	—	0.30	0.14	
	0.00004	—	—	—	0.00008	—	0.00023	0.000006	0.00023	0.00007	—	0.00009	0.00006	
28	0.200	—	—	—	0.264	—	0.89	0.024	0.54	0.232	—	0.49	0.22	
	0.00010	—	—	—	0.00019	—	0.00053	0.00001	0.0007	0.00017	—	0.0002	0.00013	
38	0.44	1.16	—	1.6	0.470	1.32	1.74	0.042	0.73	—	0.313	0.87	0.35	
	0.00033	0.00086	—	0.00151	0.00046	0.00135	0.00155	0.00004	0.001	—	0.00038	0.0005	0.00035	
42	0.69	1.75	—	2.44	0.772	2.05	2.74	0.065	1.26	—	0.608	1.4	0.47	
	0.00067	0.00178	—	0.00281	0.00111	0.00291	0.00343	0.00008	0.0032	—	0.00089	0.0011	0.00068	
48	0.80	2.44	—	3.34	1.01	2.78	3.72	0.086	1.45	—	0.755	1.92	0.62	
	0.0012	0.00308	—	0.00473	0.00174	0.00484	0.00570	0.00013	0.0043	—	0.001358	0.0018	0.0011	
55	—	3.68	—	5.05	—	4.08	5.57	0.11	2.58	—	1.243	2.93	0.90	
	—	0.00615	—	0.00948	—	0.00926	0.01193	0.00023	0.0105	—	0.002920	0.0037	0.0021	
65	—	5.67	—	6.79	—	6.04	8.22	0.17	3.10	—	1.635	4.36	1.31	
	—	0.01240	—	0.01516	—	0.01789	0.02079	0.00043	0.0149	—	0.004891	0.0069	0.0039	
75	—	8.72	—	10.5	—	9.53	14.3	0.32	4.46	—	2.511	6.80	1.97	
	—	0.02644	—	0.03269	—	0.03946	0.05069	0.001166	0.0281	—	0.01050	0.0151	0.0082	
90	—	14.8	—	18.7	—	18.2	24.0	0.57	6.94	—	4.151	12.84	3.45	
	—	0.06730	—	0.08742	—	0.15086	0.13151	0.00326	0.0651	—	0.02723	0.0448	0.0224	
100	—	—	19.7	—	—	—	—	0.82	10.2	—	6.350	16.16	—	
	—	—	0.11694	—	—	—	—	0.00592	0.1165	—	0.05273	0.0798	—	
110	—	—	27.4	—	—	—	—	1.14	—	—	8.578	21.35	—	
	—	—	0.20465	—	—	—	—	0.01048	—	—	0.09121	0.2824	—	
125	—	—	42.3	—	—	—	—	1.56	—	—	12.598	34.33	—	
	—	—	0.40727	—	—	—	—	0.01878	—	—	0.17469	0.3229	—	
140	—	—	58.1	—	—	—	—	2.02	—	—	17.271	48.69	—	
	—	—	0.67739	—	—	—	—	0.02989	—	—	0.29247	0.4917	—	
160	—	—	84.2	—	—	—	—	3.08	—	—	26.305	71.08	—	
	—	—	1.31729	—	—	—	—	0.06049	—	—	0.59436	0.9693	—	
180	—	—	118.5	—	—	—	—	5.04	—	—	33.076	109.43	—	
	—	—	2.30835	—	—	—	—	0.13295	—	—	0.97394	1.9650	—	

Weight and mass moment of inertia each refer to the average finish bore without feather keyway.

For continuously updated data please refer to our online catalogue at www.ktr.com

ROTEX® Flexible jaw couplings

Weights and mass moments of inertia

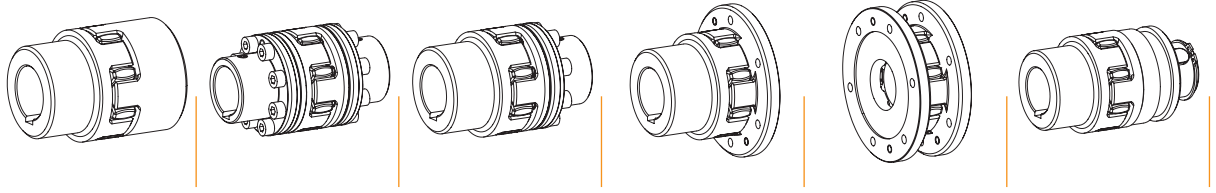

ROTEX® Complete coupling types												
Size	standard		AFN		BFN		CF		DF		SD	
	Weight [kg]	Mass moment of inertia J [kgm²]	Weight [kg]	Mass moment of inertia J [kgm²]	Weight [kg]	Mass moment of inertia J [kgm²]	Weight [kg]	Mass moment of inertia J [kgm²]	Weight [kg]	Mass moment of inertia J [kgm²]	Weight [kg]	Mass moment of inertia J [kgm²]
19	0.51	0.000121	—	—	—	—	0.44	0.00016	0.38	0.00020	0.42	0.00008
24	1.1	0.000466	0.98	0.00036	1.1	0.00041	0.84	0.00047	0.57	0.00047	1.1	0.00046
28	1.8	0.00107	1.6	0.00083	1.7	0.00095	1.5	0.00124	1.1	0.00141	1.9	0.00106
38	2.5	0.00171	2.8	0.00209	2.6	0.00193	1.9	0.00217	1.5	0.00259	3.0	0.00435
42	3.9	0.00476	4.5	0.00472	4.1	0.00419	3.1	0.00513	2.6	0.00662	4.4	0.00804
48	5.3	0.00805	5.9	0.00736	5.5	0.00684	3.9	0.00755	3.0	0.00881	6.2	0.00223
55	7.9	0.01564	8.9	0.01480	8.3	0.01369	6.4	0.01692	5.3	0.02131	9.8	0.0166
65	11.9	0.03071	12.9	0.0266	12.3	0.0259	8.9	0.02780	6.4	0.003037	14.9	0.0326
75	18.6	0.06706	20.6	0.0601	19.3	0.0572	13.5	0.0557	9.2	0.05741	23.2	0.0706
90	33.6	0.22139	37.8	0.1718	34.2	0.1551	22.3	0.1356	14.5	0.1333	40.5	0.1891
100	40.2	0.23976	49.6	0.3068	45.2	0.2737	30.9	0.2401	21.2	0.2394	46.7	0.2467
110	56.0	0.42027	67.5	0.5385	61.7	0.4793	42.9	0.4324	29.8	0.4446	61.5	0.4186
125	86.2	0.83426	102.6	1.0485	94.4	0.9413	64.4	0.8187	42.2	0.8031	96.8	0.8497
140	118.3	1.38607	141.2	1.743	129.7	1.564	90.4	1.4221	62.5	1.4580	127.8	1.368
160	171.6	2.69781	210.3	3.517	190.9	3.107	127.6	2.589	83.6	2.4805	190.3	2.723
180	242.25	4.75449	306.6	6.582	274.4	5.668	175.1	4.448	107.9	4.141	262.2	4.810

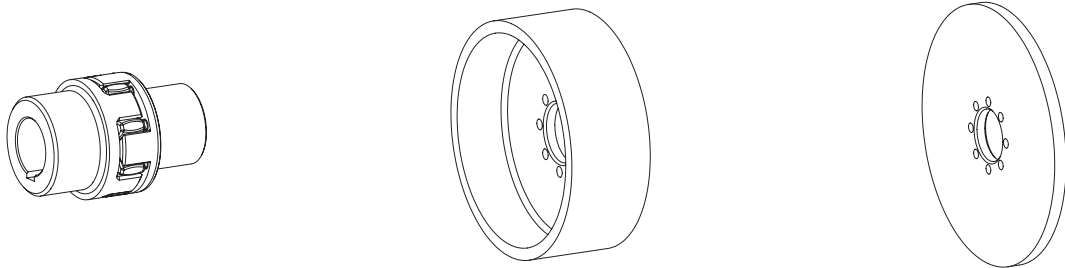

BTAN/SBAN without drum/disk		
Size	Weight [kg]	Mass moment of inertia J [kgm²]
28	0.90	0.0004
38	2.10	0.0014
42	3.24	0.0031
48	4.41	0.0053
55	6.60	0.0105
65	10.1	0.0209
75	15.4	0.0442
90	27.6	0.1224
100	36.9	0.2074
110	50.9	0.3665
125	79.1	0.7349
140	109.0	1.2292
160	161.9	2.4569
180	232.9	4.4967

Brake drum for BTAN ¹⁾		
Brake drum ØD _B x B	Weight [kg]	Mass moment of inertia J [kgm²]
160 x 60	2.12	0.01
200 x 75	3.45	0.03
250 x 95	6.87	0.08
315 x 118	14.95	0.28
400 x 150	31.20	0.89
500 x 190	60.00	2.70
630 x 236	112.00	8.01
710 x 265	161.00	14.9
800 x 300	202.00	27.2

Brake disk for SBAN ¹⁾		
Brake disk ØA x G _S	Weight [kg]	Mass moment of inertia J [kgm²]
200 x 12.5	2.928	0.015367
250 x 12.5	4.662	0.037584
315 x 16	8.618	0.111829
400 x 16	15.230	0.315206
500 x 16	23.964	0.769963
630 x 20	47.716	2.426359
710 x 20	60.934	3.915100
800 x 25	94.913	7.878998
900 x 25	118.954	12.609089
1000 x 25	148.240	19.234941

Technical data

POLY-NORM® Technical data													
Size	Torque [Nm]			Max. speed [rpm] with v = 35 m/s	Torsion angle with		Torsion spring stiffness C dyn. [Nm/rad]				Max. perm. displacement [mm] ¹⁾		
	Rated torque T _{KN}	Maximum torque T _{K max}	Vibratory torque T _{KW}		T _{KN}	T _{K max}	1.0 T _{KN}	0.75 T _{KN}	0.5 T _{KN}	0.25 T _{KN}	Axial ΔK _a	Radial ΔK _r	Angular ΔK _w
28	40	80	16	9650			0.52x10 ⁴	0.332x10 ⁴	0.187x10 ⁴	0.09x10 ⁴	± 1.0	0.20	1.2
32	60	120	24	8550	4.5	6.0	0.782x10 ⁴	0.499x10 ⁴	0.282x10 ⁴	0.135x10 ⁴	± 1.0	0.25	1.4
38	90	180	36	7650			1.35x10 ⁴	0.864x10 ⁴	0.489x10 ⁴	0.234x10 ⁴	± 1.0	0.25	1.5
42	150	300	60	6950			2.63x10 ⁴	1.68x10 ⁴	0.947x10 ⁴	0.453x10 ⁴	± 1.0	0.25	1.7
48	220	440	88	6300			2.99x10 ⁴	1.91x10 ⁴	1.08x10 ⁴	0.516x10 ⁴	± 1.5	0.30	1.8
55	300	600	120	5650			3.85x10 ⁴	2.46x10 ⁴	1.39x10 ⁴	0.664x10 ⁴	± 1.5	0.30	2.0
60	410	820	164	5150	4.0	5.5	6.76x10 ⁴	4.31x10 ⁴	2.32x10 ⁴	1.17x10 ⁴	± 1.5	0.30	2.2
65	550	1100	220	4750			8.18x10 ⁴	5.22x10 ⁴	2.7x10 ⁴	1.41x10 ⁴	± 1.5	0.35	2.4
75	850	1700	340	4200			12.29x10 ⁴	7.84x10 ⁴	4.06x10 ⁴	2.12x10 ⁴	± 1.5	0.40	2.7
85	1350	2700	540	3650			24.31x10 ⁴	15.51x10 ⁴	7.49x10 ⁴	4.19x10 ⁴	± 1.5	0.40	3.0
90	2000	4000	800	3300			36.16x10 ⁴	23.07x10 ⁴	11.14x10 ⁴	6.24x10 ⁴	± 1.5	0.45	3.4
100	2900	5800	1160	2950			54.82x10 ⁴	34.98x10 ⁴	16.89x10 ⁴	9.46x10 ⁴	± 3.0	0.50	3.9
110	3900	7800	1560	2650			79.23x10 ⁴	50.55x10 ⁴	24.4x10 ⁴	13.67x10 ⁴	± 3.0	0.60	4.3
125	5500	11000	2200	2350	2.5	3.5	102.3x10 ⁴	65.28x10 ⁴	31.52x10 ⁴	17.65x10 ⁴	± 3.0	0.60	4.8
140	7200	14400	2880	2100			164x10 ⁴	104.7x10 ⁴	50.85x10 ⁴	28.3x10 ⁴	± 3.0	0.60	5.5
160	10000	20000	4000	1900			209.1x10 ⁴	133.4x10 ⁴	64.82x10 ⁴	36.07x10 ⁴	± 3.0	0.65	6.1
180	13400	26800	5360	1650			267.1x10 ⁴	170.4x10 ⁴	82.79x10 ⁴	46.07x10 ⁴	± 3.0	0.65	6.0
200	19000	38000	7600	1450			359.5x10 ⁴	226.2x10 ⁴	109.2x10 ⁴	60.2x10 ⁴	± 4.0	0.65	7.8
220	30000	60000	12000	1300			513.8x10 ⁴	328.9x10 ⁴	157.9x10 ⁴	84.9x10 ⁴	± 4.0	0.70	8.7
240	43000	86000	17200	1200	1.5	2.1	687.9x10 ⁴	438.3x10 ⁴	209.1x10 ⁴	109.2x10 ⁴	± 4.0	0.70	9.6
260	55000	110000	22000	1000			884.8x10 ⁴	579.4x10 ⁴	275.9x10 ⁴	139.9x10 ⁴	± 4.0	0.85	11.3
280	67000	134000	26800	950			1153.1x10 ⁴	748.7x10 ⁴	367.9x10 ⁴	182.2x10 ⁴	± 4.0	0.95	12.2

¹⁾ Displacement with n = 1500 rpm

Radial and angular displacements may occur simultaneously. The combined sum of displacements must not exceed the values listed in the table. If requested, coupling is dynamically balanced (semi-key balancing G 6.3 with 1500 rpm). For circumferential speeds exceeding v = 20 m/s dyn. balancing is recommended.

Axial displacement ΔK_a

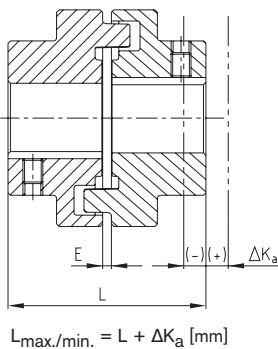

Radial displacement ΔK_r

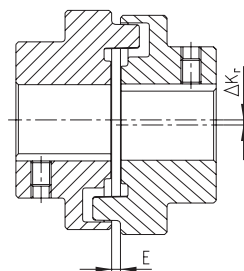

Angular displacement ΔK_w

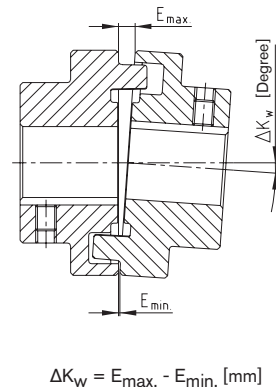

Advice for assembly

With assembly the coupling halves must be mounted such that coupling and shaft are flush. Alignment must be made such that radial and angular displacement is as small as possible. The service life of coupling and bearings is extended by accurate alignment. Steps must be taken to ensure that the alignment does not change during all operating conditions. Shaft displacement which cannot be avoided must not exceed the figures specified in the table. Angular and radial displacement may occur simultaneously. The combined sum of displacements must not exceed the values listed in the table. See KTR assembly instructions, KTR standard 495 10 at our homepage www.ktr.com.

General information about the elastomer

Material/hardness	Perbunan [NBR]/78 Shore A
Permanent temperature range [°C]	-30 to +80
Max. temperature (short time) [°C]	-50 to +120
Operating range	General engineering Pump industry ATEX applications Chemical industry Standard applications with average elasticity
Resistant to	Gasoline, diesel Acids, bases Tropics (Salt) water (hot/cold) Oils, greases Propane, butane Natural gas, city gas



Elastomer ring NBR 78 Shore A

Elastomer ring Viton [FKM] 60 Shore A for the high-temperature range on request.

POLY-NORM® Flexible couplings

Selection of standard IEC motors

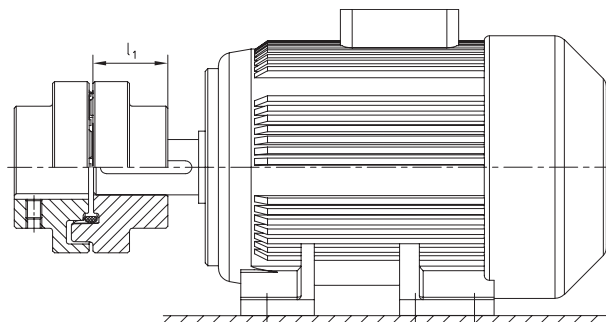

POLY-NORM® couplings for standard IEC motors, protection class IP 54/IP 55 (elastomer ring 78 Shore A)														
A. C. motor 50 Hz			Motor power n= 3000 rpm 2 poles		POLY-NORM® coupling size	Motor power n= 1500 rpm 4 poles		POLY-NORM® coupling size	Motor power n= 1000 rpm 6 poles		POLY-NORM® coupling size	Motor power n= 750 rpm 8 poles		POLY-NORM® coupling size
Size	Shaft end dcl [mm]		Power P [kW]	Torque T [Nm]		Power P [kW]	Torque T [Nm]		Power P [kW]	Torque T [Nm]		Power P [kW]	Torque T [Nm]	
	2 poles	4, 6, 8 poles												
56	9 x 20		0.09	0.32		0.06	0.43		0.037	0.43				
			0.12	0.41		0.09	0.64		0.045	0.52				
63	11 x 23		0.18	0.62		0.12	0.88		0.06	0.7				
			0.25	0.86		0.18	1.3		0.09	1.1				
71	14 x 30		0.37	1.3		0.25	1.8		0.18	2		0.09	1.4	
			0.55	1.9		0.37	2.5		0.25	2.8		0.12	1.8	
80	19 x 40		0.75	2.5	28/32	0.55	3.7	28/32	0.37	3.9	28/32	0.18	2.5	28/32
			1.1	3.7		0.75	5.1		0.55	5.8		0.25	3.5	
90S	24 x 50		1.5	5		1.1	7.5		0.75	8		0.37	5.3	
90L			2.2	7.4		1.5	10		1.1	12		0.55	7.9	
100L	28 x 60		3	9.8		2.2	15		1.5	15		0.75	11	
						3	20					1.1	16	
112M			4	13		4	27		2.2	22		1.5	21	
132S			5.5	18		5.5	36		3	30		2.2	30	
132M	38 x 80		7.5	25	38	7.5	49	38	4	40	38	3	40	38
									5.5	55				
160M	42 x 110		11	36		11	72		7.5	75	42	4	54	42
			15	49	42			42				5.5	74	
160L			18.5	60		15	98		11	109		7.5	100	
180M	48 x 110		22	71	48	18.5	121	48			48			48
180L						22	144		15	148		11	145	
200L	55 x 110		30	97		30	196		18.5	181	55	15	198	55
			37	120	55			55	22	215				
225S	55 x 110					37	240				60	18.5	244	60
225M	60 x 140		45	145		45	292	60	30	293		22	290	
250M	60 x 140	65 x 140	55	177	60	55	356	65	37	361	65	30	392	65
280S			75	241		75	484		45	438		37	483	
280M	75 x 140		90	289	65	90	581	75	55	535	75	45	587	75
315S			110	353		110	707		75	727		55	712	
315M	80 x 170		132	423		132	849		90	873	85	75	971	85
			160	513	75	160	1030		110	1070		90	1170	90
315L	65 x 140		200	641		200	1290		132	1280	90	110	1420	
					85				160	1550		132	1710	
315	85 x 170		250	802		250	1600		200	1930	100	160	2070	100
			315	1010		315	2020	100	250	2410	110	200	2580	110
			355	1140	90	355	2280		315	3040	125	250	3220	125
355	75 x 140	95 x 170	400	1280		400	2570	110	400	3850		315	4060	125
			500	1600		500	3210							
			560	1790	100	560	3580	125	450	4330	140	355	4570	140
400	80 x 170	110 x 210	630	2020		630	4030		500	4810		400	5150	
			710	2270	110	710	4540	140	560	5390	160	450	5790	160
			800	2560		800	5120		630	6060		500	6420	
450	90 x 170	120 x 200	900	2880	125	900	5760	160	710	6830		560	7190	180
			1000	3200		1000	6400		800	7690	180	630	8090	180

The coupling selection is based on an ambient temperature up to +30 °C. The selection is based on a minimum safety factor of 2 versus the max. coupling torque ($T_{K \max}$). A detailed selection is possible according to catalogue, page 15 et seqq. Drives with periodical torque curves must be selected according to DIN 740 part 2. If requested, KTR will perform the selection.
Torque T = rated torque according to Siemens catalogue M 11 · 1994/95.

POLY-NORM® AR Flexible couplings

Two-part

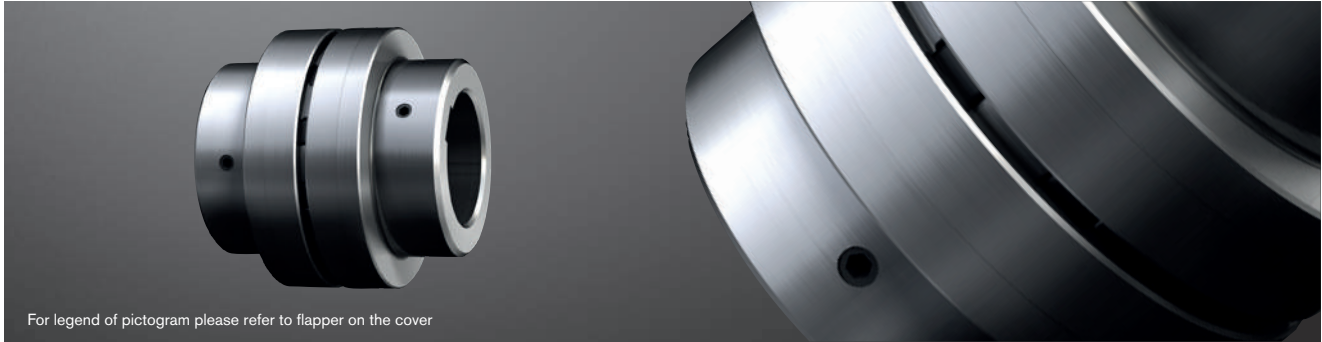

For legend of pictogram please refer to flapper on the cover

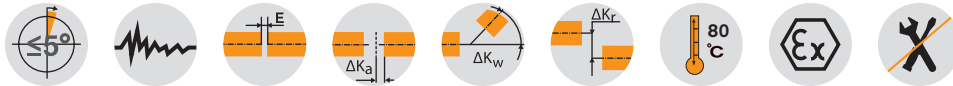

Components

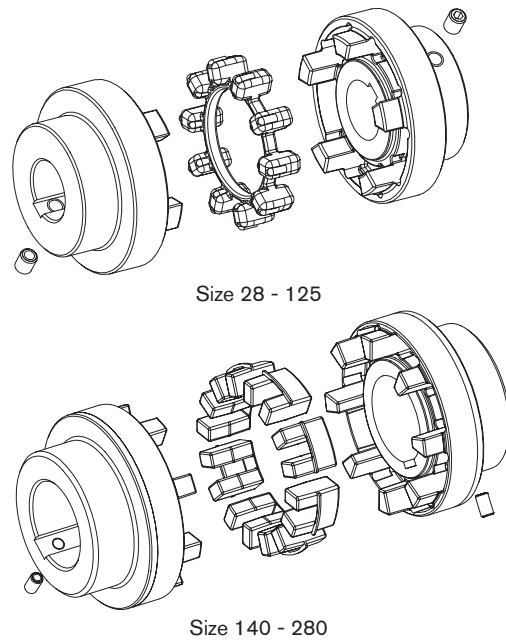
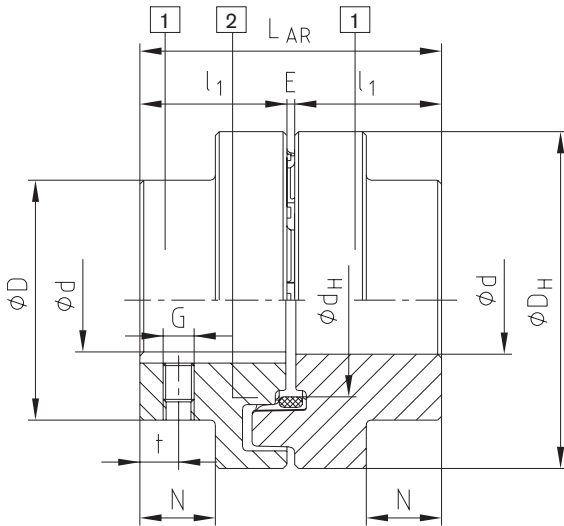

Size 28 - 125

Size 140 - 280

Components of type AR:
1 = Standard hub (GJL)
2 = Elastomer ring (up to size 180: NBR 78 ShA; from size 200: T-PUR® 84 ShA)

POLY-NORM® Type AR														
Size	Elastomer ring ¹⁾ (part 2) Torque [Nm]		Max. finish bore d ²⁾	Dimensions [mm]									Mass moment of inertia ³⁾ [kgm ²]	Weight ³⁾ [kg]
				General						Thread for setscrews ²⁾				
	T _{KN}	T _{Kmax.}		L _{AR}	l ₁	E	D _H	D	d _H	N	G	t		
28	40	80	30	59	28	3	69	46	36.5	12	M5	7	0.0004	0.9
32	60	120	35	68	32	4	78	53	41.5	14	M8	7	0.0008	1.4
38	90	180	40	80	38	4	87	62	50	19.5	M8	10	0.0016	2.0
42	150	300	45	88	42	4	96	69	55.5	20	M8	10	0.0026	2.7
48	220	440	50	101	48	5	106	78	64	24	M8	15	0.0042	3.7
55	300	600	60	115	55	5	118	90	73	29	M8	14	0.0070	5.5
60	410	820	65	125	60	5	129	97	81	33	M8	15	0.0112	6.9
65	550	1100	70	135	65	5	140	105	86	36	M10	20	0.0174	8.8
75	850	1700	80	155	75	5	158	123	100	42.5	M10	20	0.028	13.5
85	1350	2700	90	175	85	5	182	139	116	48.5	M10	25	0.052	19.5
90	2000	4000	95	185	90	5	200	148	128	49	M12	25	0.090	23.2
100	2900	5800	110	206	100	6	224	165	143	55	M12	25	0.160	31.9
110	3900	7800	50-120	226	110	6	250	185	158	60	M16	30	0.317	38.0
125	5500	11000	55-140	256	125	6	280	210	178	70	M16	35	0.570	55.2
140	7200	14400	65-155	286	140	6	315	235	216	76.5	M20	35	1.030	92.6
160	10000	20000	75-175	326	160	6	350	265	246	94.5	M20	45	1.746	126.9
180	13400	26800	75-200	366	180	6	400	300	290	111.5	M20	50	3.239	181.8
200	19000	38000	85-200	408	200	8	450	335	-	126	M24	50	5.728	263.7
220	30000	60000	95-220	448	220	8	500	370	-	140	M24	50	9.489	355.9
240	43000	86000	105-240	488	240	8	550	405	-	154	M24	50	14.963	466.3
260	55000	110000	115-260	530	260	10	650	440	-	158	M24	60	29.504	672.2
280	67000	134000	125-280	570	280	10	700	475	-	172	M24	60	42.451	836.6

¹⁾ Standard material Perbunan [NBR] 78 Shore A, size 140 - 280 double tooth elastomers, for selection see page 14 et seqq.

²⁾ Bores H7 with keyway to DIN 6885 sheet 1 [JS9] and thread for setscrew on the keyway

³⁾ Referring to average bore

POLY-NORM® AR Flexible couplings

For taper clamping sleeve

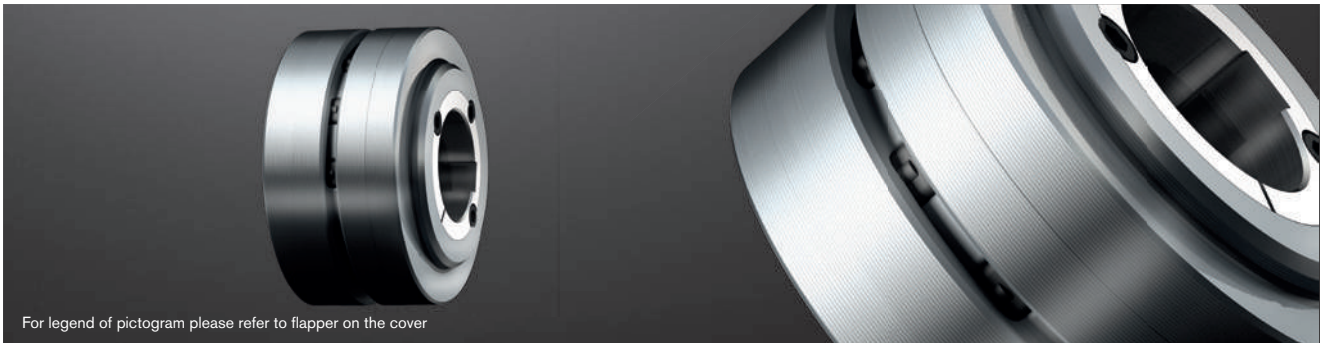

For legend of pictogram please refer to flapper on the cover



Components

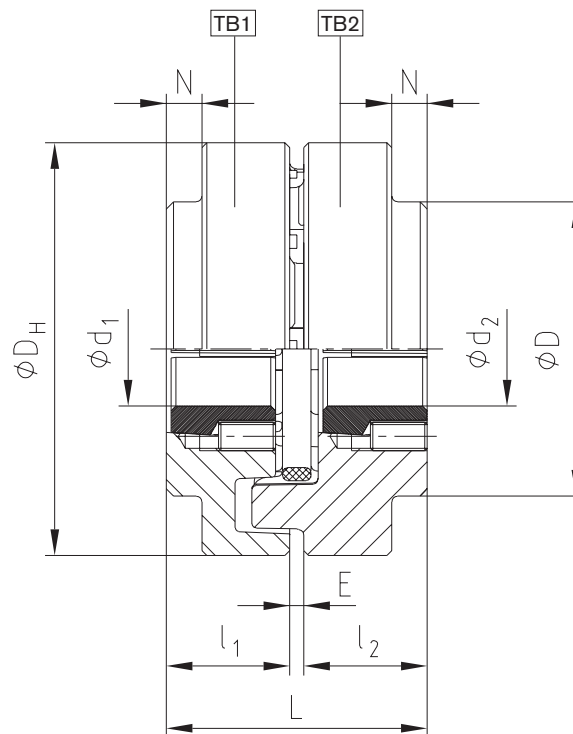

POLY-NORM® for taper clamping sleeve

Size	Taper clamping sleeve	Dimensions [mm]		Fastening screws ¹⁾ for taper clamping sleeve				Size	Taper clamping sleeve	Dimensions [mm]		Fastening screws ¹⁾ for taper clamping sleeve			
		Max. d1, d2	l1, l2	Size [Inch]	Length [mm]	SW [mm]	TA [Nm]			Max. d1, d2	l1, l2	Size [Inch]	Length [mm]	SW [mm]	TA [Nm]
32	1108	25	25.5	1/4"	13	3	5.7	75	2517	60	52.5	1/2"	25	6	49
42	1210	32	31.0	3/8"	16	5	20	85	2517	60	46.5	1/2"	25	6	49
48	1610	40	30.0	3/16"	16	5	20		3030	75	82	5/8"	32	8	90
	1615	40	42.5	3/8"	16	5	20	3020	75	52.0	5/8"	32	8	92	
60	2012	50	38.5	7/16"	22	6	31	100	3535	90	98.0	1/2"	38	10	115
65	2517	60	62.5	1/2"	25	6	49	125	4040	100	111.5	5/8"	45	12	172

¹⁾ Each 2 fastening screws, with 3535/4040 3-off
For coupling type TB1 screwing on cam side - TB2 screwing on collar side
Combination possible! Please order our separate dimension sheet (M407045).

Ordering example:	POLY-NORM® 38	AR	Ø38	Ø30
	Coupling size	Type	Finish bore	Finish bore

POLY-NORM® ADR Flexible couplings

Three-part

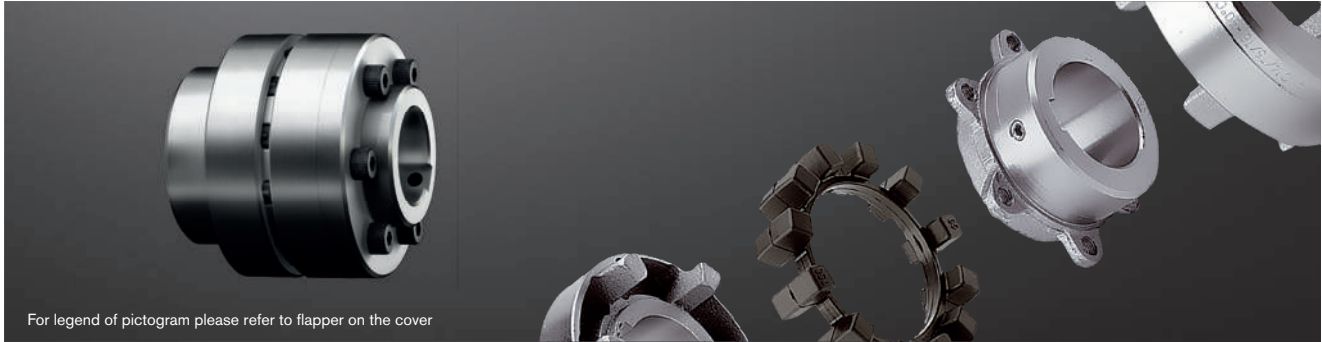

For legend of pictogram please refer to flapper on the cover



Components

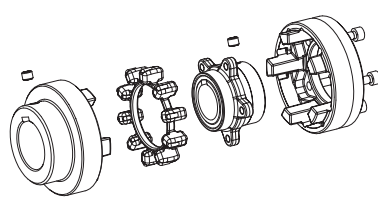
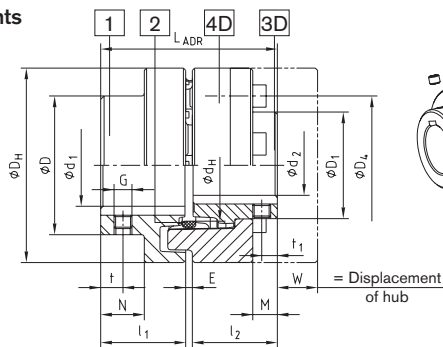

Size 38 - 125

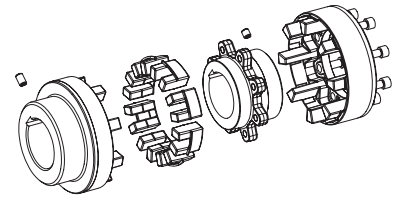

Size 140 - 280

Components of type ADR (three-part):
 1 = Standard hub* (GJL)
 2 = Elastomer ring (up to size 180: NBR 78 ShA; from size 200: T-PUR® 84 ShA)
 3D = Flange hub (GJS); 4D = Cam ring (GJL)
 * To be used preferably on driving side

POLY-NORM® Type ADR

Size	Elastomer ring ¹⁾ (part 2) Torque [Nm]		Dimensions [mm]															
			Max. finish bore ²⁾		General										Thread for setscrews			
	TKN	TK max	d ₁	d ₂	L _{ADR}	l ₁ , l ₂	E	D _H	D	D ₁	d _H	N	M	W	G	t	t ₁	T _A [Nm]
38	90	180	40	34	80	38	4	87	62	48	50	19.5	11.0	12	M8	10	7	10
42	150	300	45	38	88	42	4	96	69	54	55.5	20	12.0	16	M8	10	7	10
48	220	440	50	44	101	48	5	106	78	62	64	24	13.7	16	M8	15	7	10
55	300	600	60	50	115	55	5	118	90	72	73	29	18.7	15	M8	14	14	10
60	410	820	65	56	125	60	5	129	97	80	81	33	22.2	14	M8	15	15	10
65	550	1100	70	60	135	65	5	140	105	86	86	36	26.7	11	M10	20	20	17
75	850	1700	80	68	155	75	5	158	123	98	100	42.5	27.8	16	M10	20	20	17
85	1350	2700	90	78	175	85	5	182	139	112	116	48.5	33.7	18	M10	25	25	17
90	2000	4000	95	85	185	90	5	200	148	122	128	49	31.5	26	M12	25	25	40
100	2900	5800	110	95	206	100	6	224	165	136	143	55	37.5	28	M12	25	25	40
110	3900	7800	50-120	105	226	110	6	250	185	150	158	60	39.5	30	M16	30	30	80
125	5500	11000	55-140	115	256	125	6	280	210	168	178	70	48.0	35	M16	35	35	80
140	7200	14400	65-155	55-135	286	140	6	315	235	195	216	76.5	47.0	59	M20	35	35	140
160	10000	20000	75-175	65-155	326	160	6	350	265	225	246	94.5	65.0	43	M20	45	45	140
180	13400	26800	75-200	65-175	366	180	6	400	300	255	290	111.5	79.0	33	M20	50	50	140
200	19000	38000	85-200	73-200	408	200	8	450	335	290	-	126	95	7	M24	50	50	240
220	30000	60000	95-220	83-220	448	220	8	500	370	320	-	140	103	8	M24	50	50	240
240	43000	86000	105-240	93-240	488	240	8	550	405	350	-	154	119	1	M24	50	50	240
260	55000	110000	115-260	103-260	530	260	10	650	440	380	-	158	109	34	M24	60	60	240
280	67000	134000	125-280	113-280	570	280	10	700	475	410	-	172	109	29	M24	60	60	240

Selection of cap screws DIN EN ISO 4762 - 12.9

Size	M x l [mm]	z = number	Pitch z x angle	D ₄ [mm]	T _A [Nm] ³⁾	Size	M x l [mm]	z = number	Pitch z x angle	D ₄ [mm]	T _A [Nm] ³⁾
38	M6x16	5	5x72	62	10	110	M16x40	8	8x45	183	210
42	M8x16	5	5x72	69	25	125	M20x40	8	8x45	202	410
48	M8x20	6	6x60	78	25	140	M20x50	8	8x45	237	410
55	M8x20	6	6x60	88	25	160	M20x55	9	9x40	267	410
60	M8x20	6	6x60	98	25	180	M20x60	10	10x36	304	410
65	M10x20	6	6x60	104	49	200	M20x60	10	10x36	342	580
75	M10x25	6	6x60	120	49	220	M24x70	10	10x36	378	1000
85	M12x25	6	6x60	138	86	240	M27x70	10	10x36	416	1500
90	M16x30	6	6x60	149	210	260	M30x90	10	10x36	480	2000
100	M16x30	6	6x60	163	210	280	M30x90	10	10x36	520	2000

¹⁾ Standard material Perbunan [NBR] 78 Shore A, size 140 - 280 double tooth elastomers, for selection see page 14 et seqq.

²⁾ Bores H7 with keyway to DIN 6885 sheet 1 [JS9] and thread for setscrew ³⁾ Screw tightening torques acc. to 8.8

Ordering example:	POLY-NORM® 65	ADR	d ₁ = Ø55	d ₂ = Ø60
	Coupling size	Type	Finish bore	Finish bore

POLY-NORM[®] BTA and SBA Flexible couplings

With brake drum/brake disk for brake stop

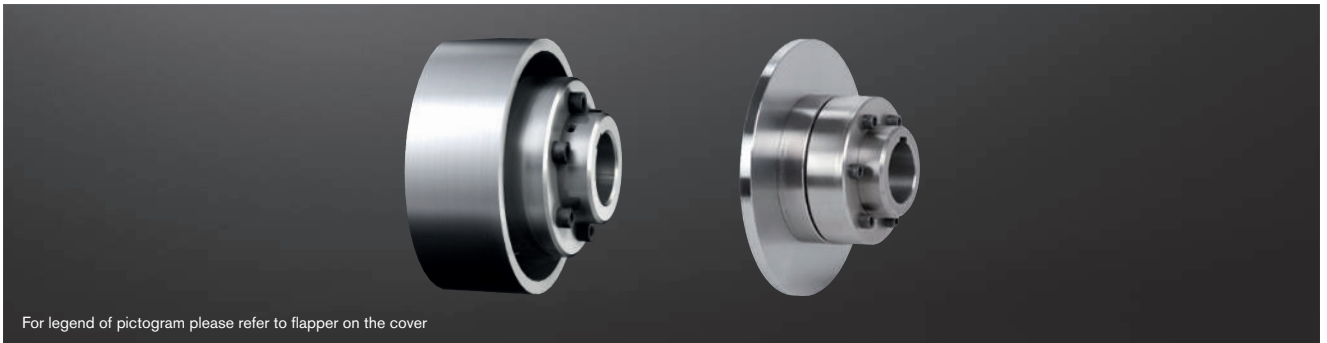

Components

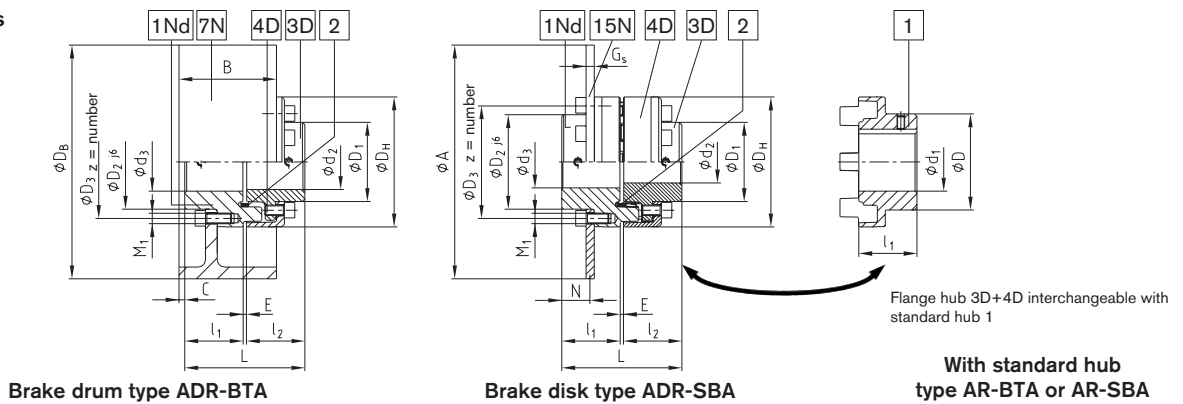

POLY-NORM[®] Type AR-BTA, AR-SBA, ADR-BTA and ADR-SBA

Size	Elastomer ring ¹⁾ (part 2) Torque [Nm]		D, D ₁	Dimensions [mm]										
	T _{KN}	T _{K max}		Max. finish bore			D _H	D ₂	D ₃	z	M ₁	l ₁ , l ₂	E	L
38	90	180	For dimensions D, D ₁ please refer to our company catalogue on page 61 and 63	d ₁	d ₂	d ₃	87	61	75	5 x 72°	M6	38	4	80
42	150	300		40	34	38	96	68	82	5 x 72°	M8	42	4	90
48	220	440		50	44	48	106	77	92	6 x 60°	M8	48	5	101
55	300	600		60	50	55	118	88	104	6 x 60°	M8	55	5	115
60	410	820		65	56	60	129	96	114	6 x 60°	M8	60	5	125
65	550	1100		70	60	65	140	104	122	6 x 60°	M10	65	5	135
75	850	1700		80	68	75	158	121	140	6 x 60°	M10	75	5	155
85	1350	2700		90	78	85	182	137	160	6 x 60°	M12	85	5	175
90	2000	4000		95	85	90	200	146	174	6 x 60°	M16	90	5	185
100	2900	5800		110	95	100	224	164	195	6 x 60°	M16	100	6	206
110	3900	7800		50-120	105	50-110	250	184	218	8 x 45°	M16	110	6	226
125	5500	11000		55-140	115	55-125	280	208	245	8 x 45°	M20	125	6	256
140	7200	14400		65-155	55-135	65-140	315	233	276	8 x 45°	M20	140	6	286
160	10000	20000		75-175	65-155	75-160	350	263	308	9 x 40°	M20	160	6	326
180	13400	26800		75-200	65-175	75-180	400	298	349	10 x 36°	M20	180	6	366

POLY-NORM[®] Type BTA POLY-NORM[®] Type SBA

POLY-NORM [®] size ØD _B xB Brake drum ²⁾	Dimensions C [mm]																Max. speed [rpm] with v = 60 m/s ³⁾	POLY-NORM [®] size ØAxG Brake disk ²⁾	Dimensions N [mm]																Max. speed [rpm] with v = 60 m/s ³⁾
	38	42	48	55	60	65	75	85	90	100	110	125	140	160	180	38			42	48	55	60	65	75	85	90	100	110	125	140	160	180			
160x60	4															7150	200x12.5	13.75												5725					
200x75	9	8	4													5725	250x12.5	13.75	14.75	18.75										4575					
250x95	17	16	20	7	3	0										4575	315x16		13	17	22	26	29	35.5					3625						
315x118		25	21	16	12	9	2.5	-3.5								3625	400x16			17	22	26	29	35.5	41.5	42	48		2850						
400x150			34	28	25	22	15.5	9.5	9	3						2850	500x16				22	26	29	35.5	41.5	42	48	54	64	2275					
500x190									18	12	-2					2275	630x20									46	52	62	69	86	1800				
630x236												20	13	-4		1800	710x20									46	52	62	69	86	104	1600			
710x265													24	7	-11	1600	800x25									43.5	49.5	59.5	66.5	83.5	101.5	1425			
																	900x25									49.5	59.5	66.5	83.5	101.5	1250				

¹⁾ Standard material Perbunan [NBR], for selection see page 14 et seqq.
²⁾ Steel ³⁾ Dynamic balancing required

Other sizes on request

Ordering example:	POLY-NORM [®] 38	ADR-BTA	Ø200 x 75	d ₂ = Ø32 NnD	d ₃ = Ø25 NnD
	Coupling size	Type	Brake drum Ø	Component with finish bore	Component with finish bore

POLY-NORM® ADR-SB

Flexible couplings

With brake disk for brake stop



For legend of pictogram please refer to flapper on the cover

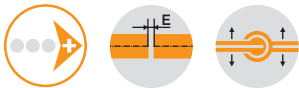

Components

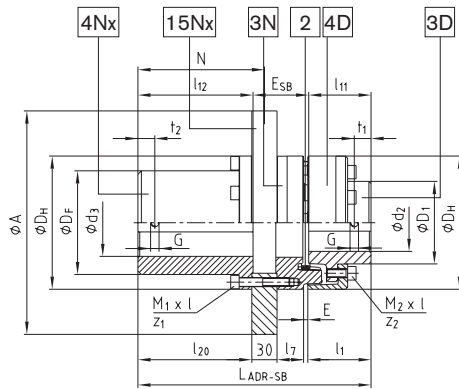

Type ADR-SB with brake disk

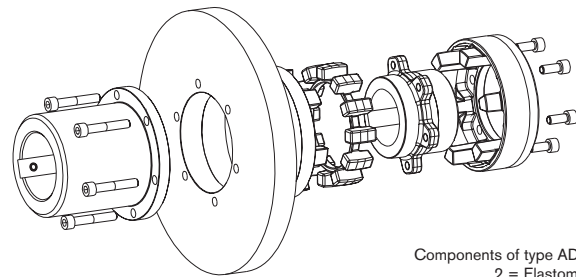

- Components of type ADR-SB:
 2 = Elastomer ring
 3D = Flange hub
 4D = Cam ring
 3N = Driving flange
 15Nx = Brake disk
 4Nx = Coupling flange

POLY-NORM® Type ADR-SB																			
Size	Elastomer ring ¹⁾ (part 2) Torque [Nm]		Max. finish bore		Dimensions [mm]												Thread for setscrews		
	TKN	TK max	d ₂	d ₃	D _H	N	l ₂	E	l ₁₁	l ₁₂	DF	l ₇	l ₂₀	L _{ADR-SB}	D ₁	ESB	G	t ₁ , t ₂	T _A [Nm]
55	300	600	50	65	118	150	55	5	54.7	136.5	88	24.0	135	249.0	72	57.8	M8	15	10
60	410	820	56	70	129	150	50	5	59.2	136.5	97	25.0	135	255.0	80	59.3	M8	20	10
65	550	1100	60	75	140	150	65	5	63.7	136.5	105	26.5	135	261.5	86	61.3	M10	20	17
75	850	1700	68	90	158	150	75	5	74.0	136.5	123	31.5	135	276.5	98	66.0	M10	20	17
85	1350	2700	78	100	182	150	85	5	84.7	136.5	139	35.0	135	290.0	112	68.8	M10	25	17
90	2000	4000	85	110	200	150	90	5	89.5	136.5	148	39.5	135	299.5	122	73.5	M12	25	40
100	2900	5800	95	120	224	190	100	6	95.5	177.0	165	43.0	175	354.0	136	81.5	M12	25	40
110	3900	7800	105	135	250	190	110	6	105.5	177.0	185	48.0	175	369.0	150	86.5	M16	30	80
125	5500	11000	115	155	280	195	125	6	120.5	182.0	210	53.0	180	394.0	168	91.5	M16	35	80
140	7200	14400	135	170	315	195	140	6	130.0	182.0	235	60.5	180	416.5	195	104.5	M20	35	140
160	10000	20000	155	195	350	195	160	6	150.0	182.0	265	62.5	180	438.5	225	106.5	M20	45	140

Selection of brake disks and cap screws							
Size	ØA brake disk [mm]/ 30 mm thick ²⁾³⁾	Cap screws DIN EN ISO 4762 for brake disk			Cap screws DIN EN ISO 4762 for flange hub/cam ring		
		M ₁ x l	z ₁ = number	Tightening torque T _A [Nm]	M ₂ x l	z ₂ = number	Tightening torque T _A [Nm]
55	250 - 450	M8x20	6	10	M8x20	6	25
60	250 - 500	M8x20	6	10	M8x20	6	25
65	315 - 500	M8x55	6	35	M10x20	6	49
75	315 - 560	M10x60	6	69	M10x25	6	49
85	355 - 560	M10x60	6	69	M12x25	6	86
90	400 - 710	M12x65	6	120	M16x30	6	210
100	400 - 800	M12x65	6	120	M16x30	6	210
110	450 - 900	M16x75	8	295	M16x40	8	210
125	450 - 900	M16x75	8	295	M20x40	8	410
140	500 - 900	M20x80	8	410	M20x50	8	410
160	560 - 900	M20x90	9	410	M20x55	9	410

¹⁾ Standard material Perbunan [NBR], for selection see page 14 et seqq.

²⁾ Steel

³⁾ For circumferential speeds exceeding v = 20 m/s, dynamic balancing is required (referring to outside diameter ØD_H).

Maximum circumferential speed v = 60 m/s (referring to the diameter of brake disk ØA).

Other sizes on request

Ordering example:	POLY-NORM® 75	ADR-SB	Ø500 x 30	3D d ₂ = Ø60 NnD	4Nx d ₃ = Ø70 NnD
	Coupling size	Type	Brake disk ØA/ width	Component with finish bore	Component with finish bore

POLY-NORM® AZR

Flexible couplings

Standard drop-out center design coupling

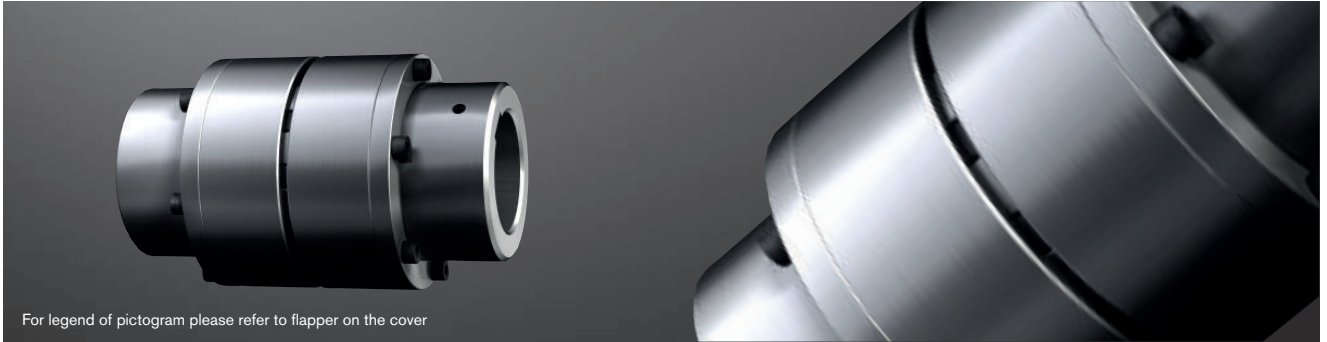

For legend of pictogram please refer to flapper on the cover



Components

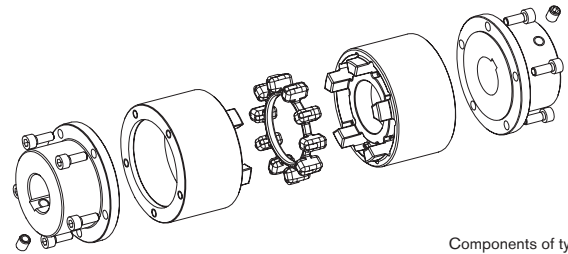
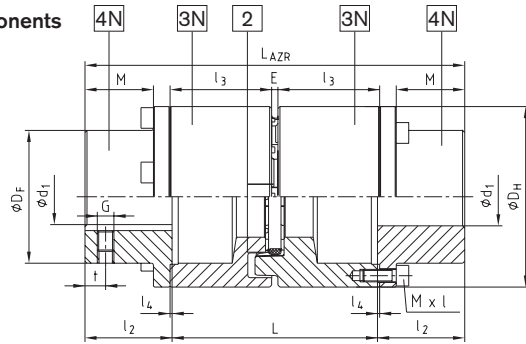

Components of type AZR:
 2 = Elastomer ring (NBR 78 ShA)
 3N = Driving flange (GJL)
 4N = Coupling flange (steel)

POLY-NORM® Type AZR

Size	Drop-out center length* L [mm]	Elastomer ring ¹⁾ (part 2) Torque [Nm]		Max. finish bore d ₁ ²⁾	Dimensions [mm]											Thread for setscrews		Mass moment of inertia ³⁾ [kgm ²]	Weight ³⁾ [kg]
		TKN	TK max		General											G	t		
					LAZR	l ₂	l ₃	E	l ₄	D _H	D _F	M	MxI	T _A [Nm]					
28	100	40	80	34	170	35	49.5	3	1	69	46	26	M6x18	14	M5	7	0.0020	2.4	
	140				210		69.5										0.0030	2.9	
32	100	60	120	38	170	35	49	4	1	78	53	26	M6x18	14	M8	7	0.0042	3.2	
	140				210		69										0.0062	3.9	
38	100	90	180	45	184	42	49	4	1	87	62	33	M6x20	14	M8	10	0.0048	4.3	
	140				224		69										0.0068	5.1	
42	100	150	300	50	190	45	49	4	1	96	69	35	M6x20	14	M8	10	0.0094	5.1	
	140				230		69										0.0128	6.0	
48	100	220	440	55	204	52	49	5	1.5	106	78	41.5	M6x20	14	M8	15	0.0170	6.6	
	140				244		69										0.0216	7.5	
55	100	300	600	65	210	55	49	5	1.5	118	88	43.5	M8x25	35	M8	14	0.0188	9.4	
	140				290		89										0.0240	10.8	
60	100	410	820	70	220	60	49	5	1.5	129	97	47.5	M8x25	35	M8	15	0.0326	11.2	
	140				260		69										0.0414	13.0	
65	140	550	1100	75	300	65	89	5	1.5	129	97	47.5	M8x25	35	M8	15	0.0504	14.6	
	180				230		49										0.0564	14.0	
75	140	850	1700	90	270	75	69	5	1.5	140	105	51.5	M8x25	35	M10	20	0.0730	15.8	
	180				310		89										0.0894	17.5	
85	140	1350	2700	100	290	90	69	5	1.5	158	123	60.5	M10x30	69	M10	20	0.0824	23.2	
	180				330		89										0.1008	25.6	
90	140	2000	4000	110	400	90	124	5	1.5	158	123	60.5	M10x30	69	M10	20	0.1332	29.8	
	180				310		69										0.1570	32.1	
100	140	2900	5800	120	350	100	89	6	2	182	139	69.5	M10x30	69	M10	25	0.1658	35.2	
	180				420		124										0.1812	40.7	
100	140	2900	5800	120	320	100	69	6	2	200	148	73.5	M12x35	120	M12	25	0.2466	38.2	
	180				360		89										0.2880	42.2	
100	140	2900	5800	120	430	100	124	6	2	224	165	83	M12x35	120	M12	25	0.3566	49.3	
	180				340		69										0.3988	50.0	
100	140	2900	5800	120	380	100	89	6	2	224	165	83	M12x35	120	M12	25	0.4450	54.8	
	180				450		124										0.5465	63.2	

¹⁾ Standard material Perbunan [NBR] 78 Shore A, for selection see page 14 et seqq.
²⁾ Bore H7 with keyway to DIN 6885 sheet 1 [JS9] and thread for setscrew on the keyway
³⁾ Referring to average bore

*For other extendable lengths (L = 120/160/195/215) it is possible to combine two driving flanges 3N with various lengths. (As an example: driving flanges POLY-NORM® 85 for extendable length 140 and 250 produce an extendable length of 195 mm (140 mm + 250 mm = 390 mm; 390 mm/2 = 195 mm)

Ordering example:	POLY-NORM® 42	AZR	140	Ø38	Ø42
	Coupling size	Type	Drop-out center length L	Finish bore	Finish bore

POLY

Flexible couplings

Selection of standard IEC motors

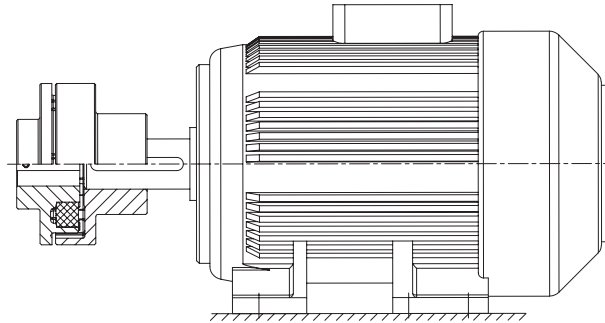

POLY couplings for standard IEC motors, protection class IP 54/IP 55

A. C. motor 50 Hz		Motor power n= 3000 rpm 2 poles		POLY coupling size	Motor power n= 1500 rpm 4 poles		POLY coupling size	Motor power n= 1000 rpm 6 poles		POLY coupling size	Motor power n= 750 rpm 8 poles		POLY coupling size
Size	Shaft end dxl [mm]	Power P [kW]	Torque T [Nm]		Power P [kW]	Torque T [Nm]		Power P [kW]	Torque T [Nm]		Power P [kW]	Torque T [Nm]	
	2 poles	4, 6, 8 poles											
56	9 x 20		0.09	0.32	8	0.06	0.43	8	0.037	0.43	8		
			0.12	0.41		0.09	0.64		0.045	0.52			
63	11 x 23		0.18	0.62	8	0.12	0.88	8	0.06	0.7	8		
			0.25	0.86		0.18	1.3		0.09	1.1			
71	14 x 30		0.37	1.3	8	0.25	1.8	8	0.18	2	8	0.09	1.4
			0.55	1.9		0.37	2.5		0.25	2.8		0.12	1.8
80	19 x 40		0.75	2.5	8	0.55	3.7	8	0.37	3.9	8	0.18	2.5
			1.1	3.7		0.75	5.1		0.55	5.8		0.25	3.5
90S	24 x 50		1.5	5	8	1.1	7.5	8	0.75	8	8	0.37	5.3
90L			2.2	7.4		1.5	10		1.1	12		0.55	7.9
100L	28 x 60		3	9.8	9	2.2	15	9	1.5	15	9	0.75	11
112M			4	13	9	3	20	9	2.2	22	9	1.1	16
			5.5	18		4	27		2.2	22		1.5	21
132S	38 x 80		7.5	25	10	5.5	36	10	3	30	10	2.2	30
132M						7.5	49		4	40		3	40
160M	42 x 110		11	36	12	11	72	12	7.5	75	12	4	54
			15	49		15	98		11	109		5.5	74
160L			18.5	60	12	15	98	12	11	109	14	7.5	100
180M	48 x 110		22	71		22	144		14	15		148	11
180L					14			14			14		
200L	55 x 110		30	97		30	196		15	18.5		181	15
			37	120	15	196	15	22	215	15	15	198	15
225S	55 x 110				17	37	240	17			17	18.5	244
225M	60 x 140	60 x 140	45	145		45	292		20	30		293	20
250M	60 x 140	65 x 140	55	177	17	55	356	17	37	361	20	30	392
280S			75	241		75	484		20	45		438	20
280M		75 x 140	90	289	20*	90	581	20	55	535	20	45	587
315S			110	353	20*	110	707	22	75	727	22	55	712
315M			132	423		132	849		25	90		873	25
	65 x 140	80 x 170	160	513	20*	160	1030	25	110	1070	25	90	1170
315L			200	641	22*	200	1290	28	132	1280	28	110	1420
						200	1290		28	160		1550	28
315		85 x 170	250	802	22*	250	1600	30	200	1930	30	160	2070
			315	1010		315	2020		30	250		2410	30
			355	1140	30	355	2280	30			30		
355	75 x 140	95 x 170	400	1280		400	2570		35	315		3040	35
			500	1600	35	500	3210	35	400	3850	35	315	4060
			560	1790		560	3580		40	450		4330	40
400	80 x 170	110 x 210	630	2020	40	630	4030	40	500	4810	40	400	5150
			710	2270		710	4540		40	560		5390	40
			800	2560	40	800	5120	40	630	6060	40	500	6420
450	90 x 170	120 x 210	900	2880		900	5760						
			1000	3200		1000	6400						

The coupling selection is based on an ambient temperature up to +30 °C. The coupling was selected for normal operation. The respective couplings have a minimum operating factor of $f_{min.} = 1.35$. Drives with periodical torque curves must be selected according to DIN 740 part 2. If requested, KTR will perform the selection.

Torque T = rated torque according to Siemens catalogue M 11 · 1994/95.

* Dynamic balancing required

POLY PKZ and PKD Flexible couplings

PKZ (two-part) and PKD (three-part)



For legend of pictogram please refer to flapper on the cover

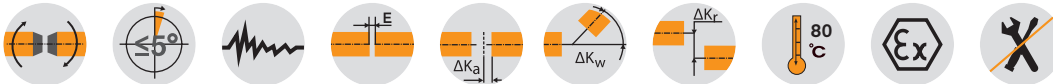

Components

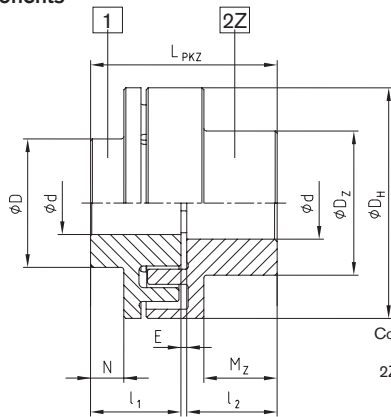

Type PKZ (Z) – (Size 8 to 30)

Components of type PKZ (Z):
1 = Cam section (GJL)
2Z = Pocket element * (GJL)
* To be used preferably on driving side

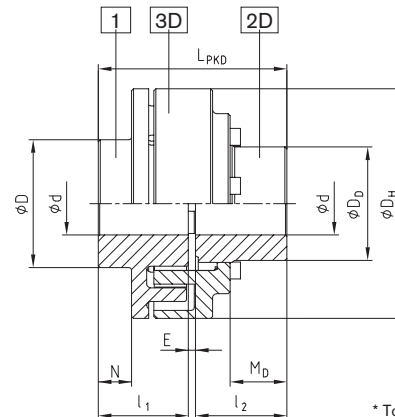

Type PKD (D) – (Size 15 to 35)

Components of type PKD (D):
1 = Cam section * (GJL)
2D = Flange hub (steel)
3D = Cam ring (GJL)
* To be used preferably on driving side

POLY Type PKZ and PKD																					
Size	Rated torque ¹⁾ TKN [Nm]	Max. speed ²⁾ n [rpm]	Max. finish bore d			Dimensions [mm]												Thread for setscrews			Weight ³⁾ [kg]
			Component 1	Component 2Z	Component 2D	D _H	D	D _Z	D _D	l ₁ , l ₂	M _Z	M _D	N	E	D ₂	D ₄ (H7/h7)	LPKZ/LPKD	G	t	T _A [Nm]	
8 (Z)	42	5000	20	28	—	86	43	50	—	35	25	—	3	3	—	—	73	M5	18	2	1.7
9 (Z)	72	5000	28	38	—	97	55	65	—	41	30	—	7	3	—	—	85	M8	23	10	2.7
10 (Z)	100	5000	32	42	—	107	60	70	—	45	35	—	10	4	—	—	94	M8	27	10	3.5
12 (Z)	170	5000	38	48	—	131	70	80	—	55	43	—	12	4	—	—	114	M8	30	10	5.4
14 (Z)	210	4800	45	55	—	142	80	93	—	60	46	—	17	4	—	—	124	M8	10	10	7.6
15 (Z;D)	320	4300	50	60	50	157	90	100	74.5	65	52	33	21	4	90	75	134	M8	15	10	8.6
17 (Z;D)	400	3800	60	65	60	176	100	110	87	70	56	43.5	26	4	106	90	144	M8	15	10	12
20 (Z;D)	820	3300	65	75	70	205	115	127	104	80	65	45	23	4	123	105	164	M8	15	10	20
22 (Z)	1100	3000	85	85	—	224	140	140	—	90	75	—	38	4	—	—	184	M10	20	17	25
25 (Z;D)	1600	2700	90	90	95	257	150	150	138	100	84	67	43	5	162	140	205	M12	20	40	35
28 (Z;D)	2500	2350	100	100	110	288	165	165	158	110	90	65	44	5	178	160	225	M12	20	40	53
30 (Z;D)	3950	2200	110	110	110	308	180	180	165	130	108	89	58	5	202	170	265	M16	20	80	66
35 (D)	6100	1850	130	—	145	373	210	—	209	160	—	102	70	5	240	210	325	M16	25	80	125

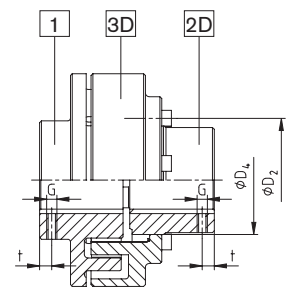

¹⁾ Maximum torque $T_{K \max} = T_{KN} \times 2$; elastomer: standard material Perbunan [NBR] 92 Shore A; hub: standard material GJL
²⁾ Speeds for $v = 30$ m/s. For circumferential speeds exceeding $v = 30$ m/s, we recommend dynamic balancing
³⁾ Referring to average bore

Ordering example:	POLY	PKD	28	$d_1 = \varnothing 90$	$d_2 = \varnothing 80$
	Coupling type	Type	Size	Finish bore component 1	Finish bore component 2

POLY PKA

Flexible couplings

Drop-out center design coupling

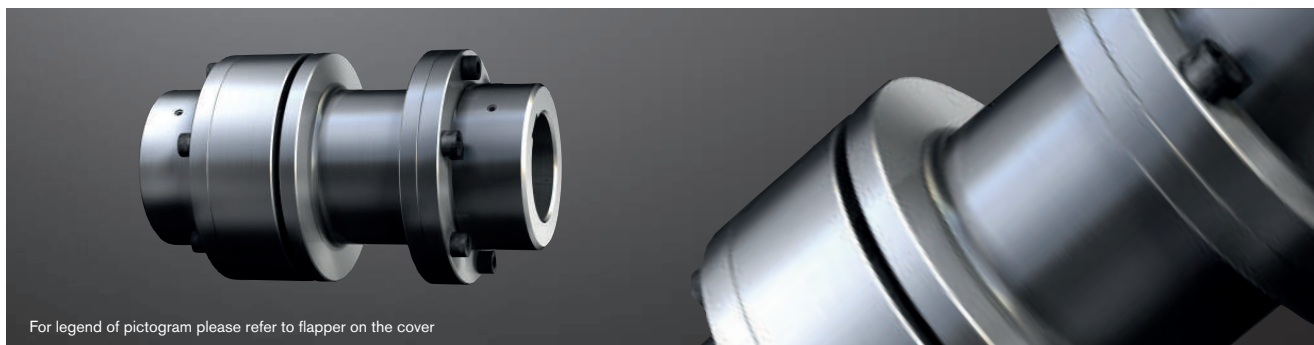

For legend of pictogram please refer to flapper on the cover



Components

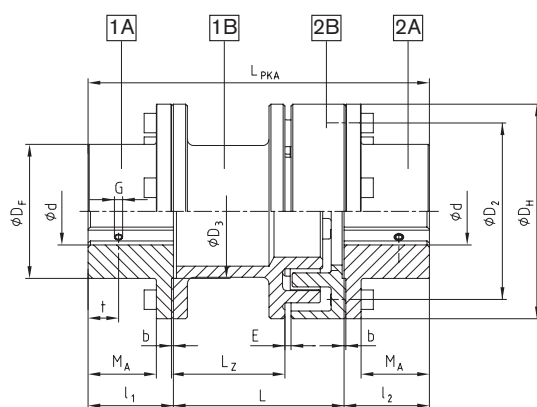

Components of type PKA:
 1A/2A = Coupling flange (steel)
 1B = Spacer (GJL)
 2B = Driving flange (GJL)
 1A and 1B to be used preferably on driving side

POLY Type PKA																		
Size	Rated torque T _{KN} [Nm]	Max. speed n [rpm]	Max. finish bore d component 1A/2A	Dimensions [mm]											Thread for setscrews			Weight [kg]
				D _H	D _F	D ₂	D ₃	l ₁ , l ₂	b	M _A	E	L	L _{PKA}	L _Z	G	t	T _A [Nm]	
8	42	5000	40	86	55	70	60	35	1.5	25.5	3	100	170	66	M5	15	2	3.04
9	72	5000	50	97	70	85	70	41	1.5	30.5	3	100	182	63	M8	15	10	4.26
												140	222	103				4.66
10	100	5000	55	107	78	93	80	46	1.5	35.5	4	100	192	61	M8	20	10	5.42
												140	232	101				5.88
12	170	5000	70	131	95	113	90	55	1.5	43.0	4	100	210	55	M8	20	10	9.49
												140	250	95				10.15
14	210	4800	75	142	105	125	100	60	1.5	48.0	4	100	220	54	M8	25	10	11.46
												140	260	94				12.23
15	320	4300	80	157	110	135	110	65	1.5	49.5	4	140	270	93	M8	25	10	15.63
												180	310	133				16.50
17	400	3800	90	176	125	150	110	70	1.5	54.5	4	100	240	53	M8	25	10	18.79
												140	280	93				19.60
20	820	3300	110	205	150	175	130	80	2.0	61.0	4	140	320	133	M8	30	10	20.41
												180	340	121				30.96
												180	340	121				32.18

Ordering example:	POLY	PKA	15	140	Ø38	Ø40
	Coupling type	Type	Size	Drop-out center length	Finish bore component 1A	Finish bore component 2A

POLY

Flexible couplings

Displacements / elastomer sets / screws

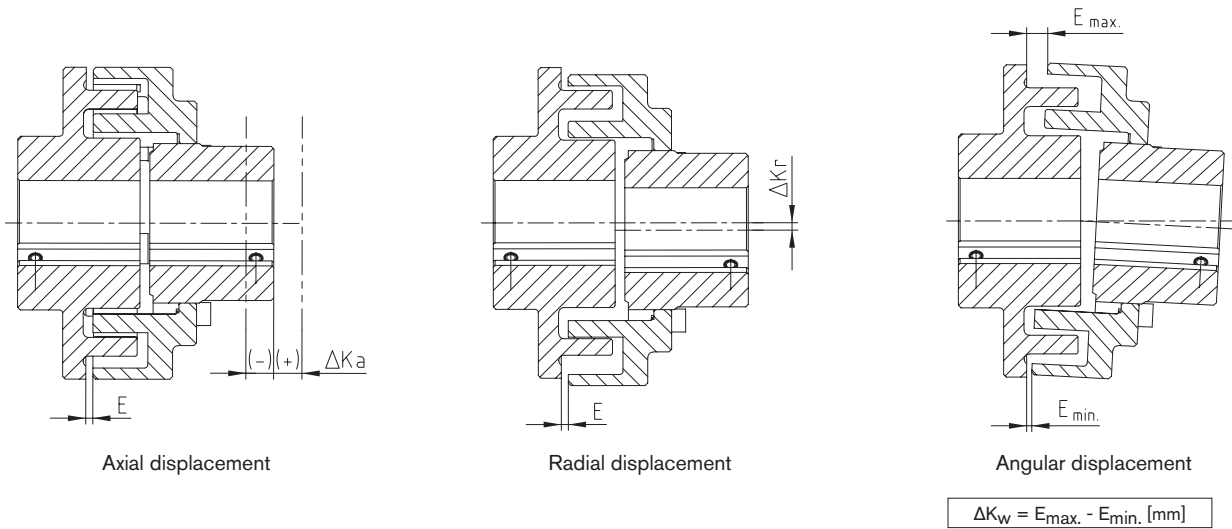

Radial and angular displacements may occur simultaneously.
 The combined sum $V = \Delta K_r \text{ [mm]} + (E_{\max} \text{ [mm]} - E_{\min} \text{ [mm]})$ must not exceed the values listed in the table.

		Displacements [mm]													
Coupling size		8	9	10	12	14	15	17	19	20	22	25	28	30	35
Max. axial displacement ΔK_a [mm]		± 1	± 1	± 1	± 2	± 2	± 2	± 2	± 2	± 2	± 2	± 2	± 2	± 2	± 3
Max. radial displacement ΔK_r or max. angular displacement ΔK_w or sum V	n=750 rpm	0.8	0.8	0.8	0.8	0.8	1.0	1.0	1.0	1.0	1.0	1.0	1.0	1.2	1.2
	n=1000 rpm	0.7	0.7	0.7	0.7	0.7	0.9	0.9	0.9	0.9	0.9	0.9	0.9	1.1	1.1
	n=1500 rpm	0.5	0.5	0.5	0.5	0.5	0.7	0.7	0.7	0.7	0.7	0.7	0.7	0.7	0.9

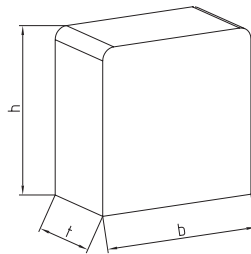

		Elastomer sets NBR (cuboid)													
Coupling size		8	9	10	12	14	15	17	19	20	22	25	28	30	35
Size of set		1			2		3		3a	4	3b	4Ü	5	6Ü	7Ü
Number of sets		8	10	10	10	10	12	12	12	12	16	16	16	16	20
Dimensions of elastomer set b x t x h [mm]	b	18.4			24.9		27.2		27.7	34.9	29.6	34.8	40	43.3	45.7
	t	10			15.3		16.1		18.4	19.6	18.4	20.1	22.2	28.6	25.0
	h	18.9			23.9		24.6		26.8	34.6	29.6	35	40.6	41.1	60.0

		Type PKD - Dimensions of cap screws acc. to DIN EN ISO 4762													
Coupling size		8	9	10	12	14	15	17	19	20	22	25	28	30	35
Screw size	M	—	—	—	—	—	M8	M8	M8	M10	M8	M10	M10	M12	M12
	I	—	—	—	—	—	30	25	25	30	30	30	40	40	55
Quantity		—	—	—	—	—	6	6	6	6	8	8	8	8	10
Tightening torque T_A [Nm]		—	—	—	—	—	25	25	25	49	25	49	49	86	86
		Type PKA - Dimensions of cap screws acc. to DIN EN ISO 4762													
Screw size	M	M6	M6	M6	M8	M8	M10	M10	—	M10	—	M10	—	—	—
	I	16	18	18	20	20	25	25	—	30	—	30	—	—	—
Quantity		4	5	5	5	5	6	6	—	6	—	8	—	—	—
Tightening torque T_A [Nm]		10	10	10	25	25	49	49	—	49	—	49	—	—	—

REVOLEX®

Flexible pin & bush coupling

Flexible jaw and pin & bush couplings

Technical data

REVOLEX® KX-D Technical data											
Size	Torque [Nm] NBR 80 Sha			Cast iron		Steel		Torsion spring stiffness C dyn. [Nm/rad]			
	Rated T _{KN}	Max. T _{K max}	Vibratory T _{KW}	Max. speed [rpm] with v = 35 m/s	Max. bore [mm]	Max. speed [rpm] with v = 60 m/s	Max. bore [mm]	0.25 T _{KN}	0.50 T _{KN}	0.75 T _{KN}	1.00 T _{KN}
KX-D 75	4300	8600	1720	-	-	4500	100	6.73x10 ⁵	1.04x10 ⁶	1.54x10 ⁶	2.17x10 ⁶
KX-D 85	5500	11000	2200	-	-	4175	110	8.66x10 ⁵	1.32x10 ⁶	1.95x10 ⁶	2.73x10 ⁶
KX-D 95	7200	14400	2880	-	-	3845	125	1.11x10 ⁶	1.70x10 ⁶	2.49x10 ⁶	3.47x10 ⁶
KX-D 105	9400	18800	3760	2000	110	3475	130	1.45x10 ⁶	2.21x10 ⁶	3.23x10 ⁶	4.51x10 ⁶
KX-D 120	15200	30400	6080	1800	125	3100	150	1.78x10 ⁶	2.48x10 ⁶	3.54x10 ⁶	4.85x10 ⁶
KX-D 135	20000	40000	8000	1600	140	2725	170	2.34x10 ⁶	3.27x10 ⁶	4.65x10 ⁶	6.36x10 ⁶
KX-D 150	25000	50000	10000	1450	160	2500	190	2.94x10 ⁶	4.12x10 ⁶	5.87x10 ⁶	8.06x10 ⁶
KX-D 170	41000	82000	16400	1250	180	2150	220	4.36x10 ⁶	7.91x10 ⁶	1.14x10 ⁷	1.50x10 ⁷
KX-D 190	54000	108000	21600	1100	205	1900	245	5.78x10 ⁶	1.05x10 ⁷	1.52x10 ⁷	1.98x10 ⁷
KX-D 215	67500	135000	27000	1000	230	1725	275	7.21x10 ⁶	1.30x10 ⁷	1.89x10 ⁷	2.47x10 ⁷
KX-D 240	98000	196000	39200	900	250	1550	310	1.19x10 ⁷	2.52x10 ⁷	3.84x10 ⁷	5.17x10 ⁷
KX-D 265	134000	268000	53600	800	285	1375	350	1.62x10 ⁷	3.44x10 ⁷	5.26x10 ⁷	7.07x10 ⁷
KX-D 280	170000	340000	68000	720	315	1225	385	2.05x10 ⁷	4.36x10 ⁷	6.66x10 ⁷	8.97x10 ⁷
KX-D 305	205000	410000	82000	675	330	1150	405	2.49x10 ⁷	5.27x10 ⁷	8.05x10 ⁷	1.08x10 ⁸
KX-D 330	265000	530000	106000	625	355	1075	435	3.20x10 ⁷	6.78x10 ⁷	1.04x10 ⁸	1.40x10 ⁸
KX-D 355	350000	700000	140000	575	380	975	450	4.26x10 ⁷	8.99x10 ⁷	1.37x10 ⁸	1.85x10 ⁸
KX-D 370	430000	860000	172000	535	450	900	530	4.92x10 ⁷	1.04x10 ⁸	1.59x10 ⁸	2.14x10 ⁸
KX-D 470	520000	1040000	208000	-	-	855	520	6.25x10 ⁷	1.33x10 ⁸	2.03x10 ⁸	2.74x10 ⁸
KX-D 520	810000	1620000	324000	-	-	740	According to customer specification	9.83x10 ⁷	2.08x10 ⁸	3.18x10 ⁸	4.28x10 ⁸
KX-D 590	1000000	2000000	400000	-	-	660	According to customer specification	1.21x10 ⁸	2.56x10 ⁸	3.91x10 ⁸	5.26x10 ⁸
KX-D 650	1350000	2700000	540000	-	-	590	According to customer specification	1.63x10 ⁸	3.47x10 ⁸	5.30x10 ⁸	7.14x10 ⁸

ROTEX®

POLY-NORM®

■ = Years of experience with applications at customer sites and additional test series in the KTR test field in Rheine enabled us to determine potentials allowing for an increase of the rated and maximum torques with some sizes of this series.

If requested, coupling is dynamically balanced (semi-key balancing G 6.3 with speed on request of customer). For circumferential speeds exceeding v = 30 m/s dyn. balancing is recommended.

Axial displacement ΔKa

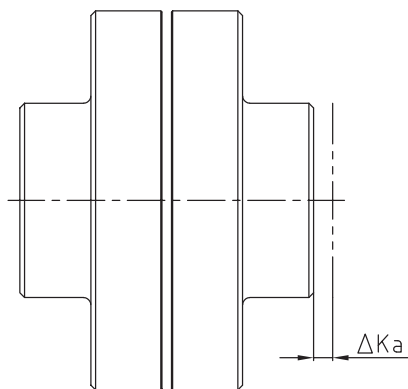

$$L_{\text{max./min.}} = L + \Delta K_a \text{ [mm]}$$

Radial displacement ΔKr

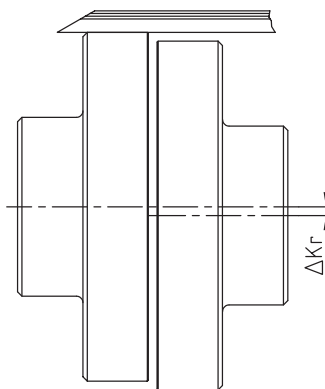

Angular displacement ΔKw

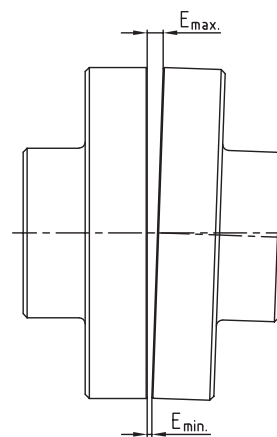

$$\Delta K_w = E_{\text{max.}} - E_{\text{min.}} \text{ [mm]}$$

		Displacements																				
Size (KX and KX-D)		75	85	95	105	120	135	150	170	190	215	240	265	280	305	330	355	370	470	520	590	650
Max. axial displacement ΔKa [mm]		±1.5	±1.5	±1.5	±2	±2	±2	±2	±2.5	±2.5	±2.5	±2.5	±2.5	±2.5	±2.5	±4	±4	±4	±4	±4	±4	±4
Max. radial displacement ΔKr [mm] or max. angular displacement ΔKw [mm] with speed n	250 rpm	0.95	1.1	1.1	1.2	1.3	1.4	1.5	1.7	1.9	2.0	2.2	2.5	2.7	2.9	3.1	3.3	3.5	3.8	4.4	4.9	5.4
	500 rpm	0.70	0.80	0.80	0.9	0.9	1.0	1.1	1.2	1.3	1.4	1.6	1.7	1.9	2.0	2.2	2.3	2.5	2.8	3.1	3.5	3.8
	750 rpm	0.60	0.65	0.65	0.7	0.8	0.8	0.9	1.0	1.1	1.2	1.3	1.4	1.6	1.7	1.8	1.9	2.0	2.2	2.4	-	-
	1000 rpm	0.50	0.55	0.55	0.6	0.7	0.7	0.8	0.9	0.9	1.0	1.1	1.2	1.4	1.4	1.5	1.7	1.8	-	-	-	-
	1500 rpm	0.40	0.45	0.45	0.5	0.5	0.6	0.6	0.7	0.8	0.8	0.9	1.0	-	-	-	-	-	-	-	-	-
	2000 rpm	0.35	0.40	0.40	0.4	0.5	0.5	0.5	0.6	0.7	-	-	-	-	-	-	-	-	-	-	-	-
3000 rpm	0.30	0.35	0.35	0.4	0.4	-	-	-	-	-	-	-	-	-	-	-	-	-	-	-	-	

Advice for assembly

The permissible displacement figures of the flexible REVOLEX® KX couplings specified are general standard values taking into account the load of the coupling up to the rated torque T_{KN} of the coupling and an ambient temperature of +30 °C. The displacement figures may only be used one by one - if they appear simultaneously, they must be limited in proportion. Care should be taken to maintain the distance dimension E accurately in order to allow for axial clearance of the coupling while in operation. See KTR assembly instructions, KTR standard 49410 at our homepage www.ktr.com.

POLY

REVOLEX®

REVOLEX® KX-D

Flexible pin & bush coupling

Material cast

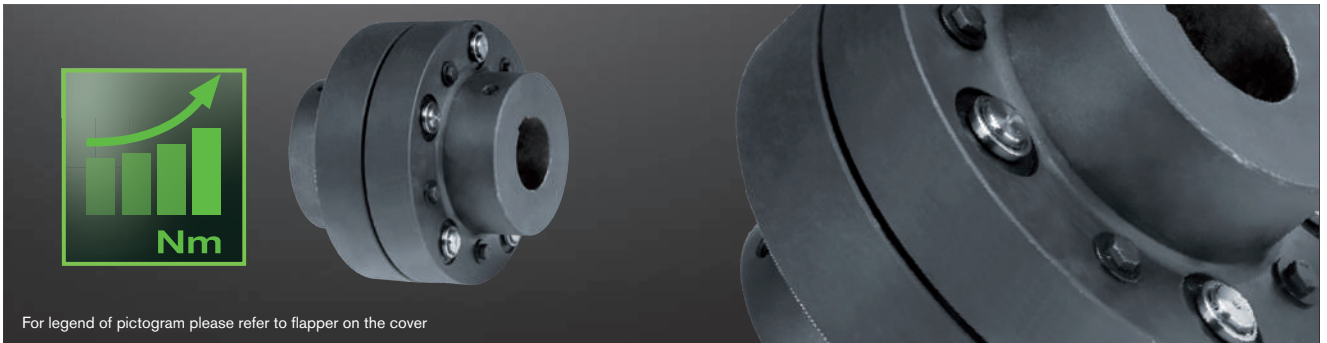

Components

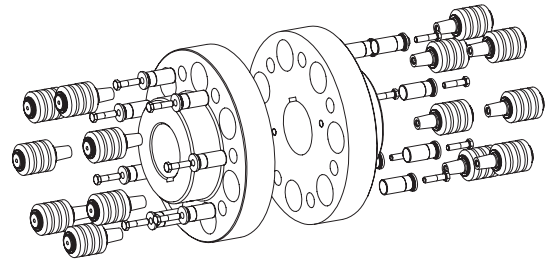
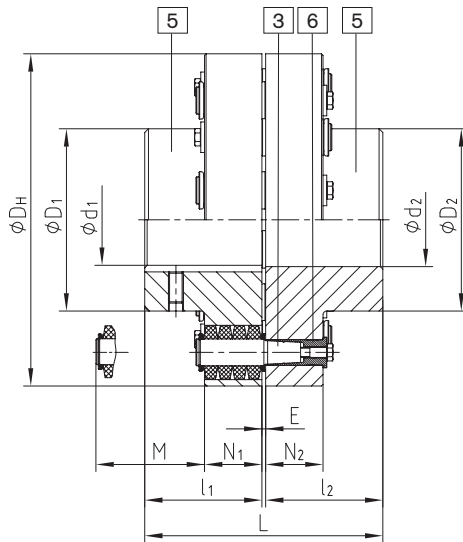

Components of type KX-D:
 5 = Hub part 5
 3 = Pins complete
 6 = KX-D sleeve (hardened and corrosion-resistant)

REVOLEX® Type KX-D													
Size	Torque ¹⁾ [Nm]		Max. speed ²⁾ [rpm]	Finish bore (min. - max.) d ₁ , d ₂	Dimensions [mm]							Mass moment of inertia ³⁾ [kgm ²]	Weight ³⁾ [kg]
	T _{KN}	T _{Kmax.}			L	l ₁ , l ₂	E	D _H	D ₁ , D ₂	N ₁ , N ₂	M*		
KX-D 105	9400	18800	2000	38-110	237	117	3	330	180	56	76	0.907	68
KX-D 120	15200	30400	1800	45-125	270	132	6	370	206	76	100	1.867	108
KX-D 135	20000	40000	1600	75-140	300	147	6	419	230	76	100	3.144	145
KX-D 150	25000	50000	1450	85-160	336	165	6	457	256	76	100	4.573	180
KX-D 170	41000	82000	1250	95-180	382	188	6	533	292	92	130	10.259	291
KX-D 190	54000	108000	1100	110-205	428	211	6	597	330	92	130	16.601	385
KX-D 215	67500	135000	1000	125-230	480	237	6	660	368	92	130	25.495	498
KX-D 240	98000	196000	900	140-250	534	264	6	737	407	122	170	50.147	760
KX-D 265	134000	268000	800	160-285	590	292	6	826	457	122	170	80.796	997
KX-D 280	170000	340000	720	180-315	628	311	6	927	508	122	170	129.979	1301
KX-D 305	205000	410000	675	180-330	654	324	6	991	533	122	170	170.016	1509
KX-D 330	265000	530000	625	200-355	666	330	6	1067	572	122	170	227.451	1755
KX-D 355	350000	700000	575	225-380	721	356	9	1156	610	164	220	415.259	2263
KX-D 370	430000	860000	535	225-450	773	382	9	1250	720	164	220	586.686	2701

■ = Years of experience with applications at customer sites and additional test series in the KTR test field in Rheine enabled us to determine potentials allowing for an increase of the rated and maximum torques with some sizes of this series.

* Drop-out center dimension required

¹⁾ Standard material Perbunan [NBR] 80 Shore A, for selection see page 18 et seqq.

²⁾ Higher speeds on request.

³⁾ Referring to max. bore

Finish bore according to ISO fit H7, feather keyway according to DIN 6885, sheet 1 [JS9].

If requested, coupling is dynamically balanced (semi-key balancing G 6.3 with speed on request of customer). For circumferential speeds exceeding $v = 30$ m/s dyn. balancing is recommended.

■ = Pilot bored available from stock

Ordering example:	REVOLEX® KX-D 170	GJL	Ø120	Ø150
	Type and size of coupling	Material	Finish bore	Finish bore

REVOLEX® KX-D

Flexible pin & bush coupling

Flexible jaw and pin & bush couplings

Material steel

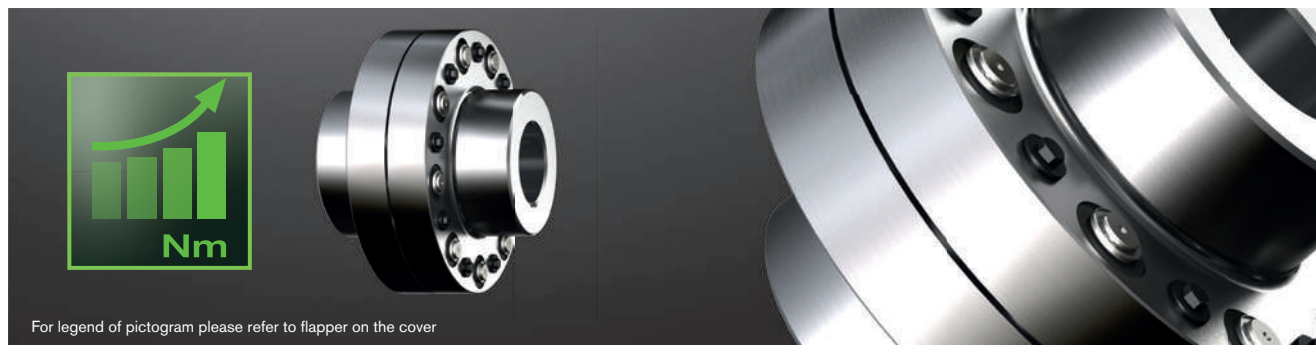

For legend of pictogram please refer to flapper on the cover



ROTEX®

Components

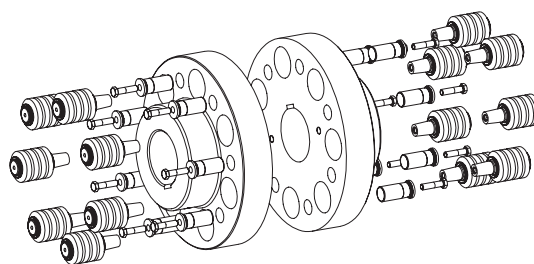
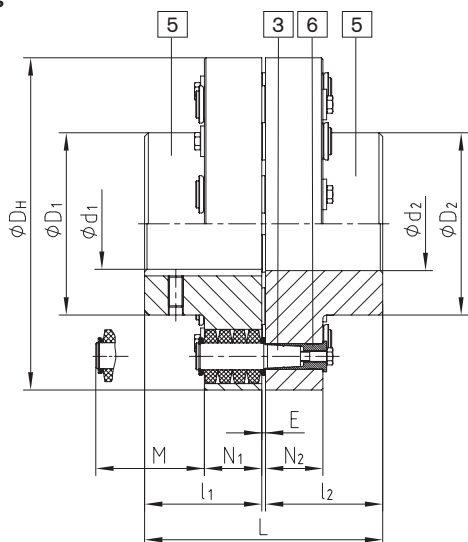

Components of type KX-D:
5 = Hub part 5
3 = Pins complete
6 = KX-D sleeve (hardened and corrosion-resistant)

POLY-NORM®

REVOLEX® Type KX-D

Size	Torque ¹⁾ [Nm]		Max. speed ²⁾ [rpm]	Finish bore (min. - max.) d ₁ , d ₂	Dimensions [mm]							Mass moment of inertia ³⁾ [kgm ²]	Weight ³⁾ [kg]
	T _{KN}	T _{Kmax.}			L	l ₁ , l ₂	E	D _H	D ₁ , D ₂	N ₁ , N ₂	M*		
KX-D 75	4300	8600	4500	0-100	193	95	3	255	136	56	76	0.325	39
KX-D 85	5500	11000	4175	0-110	213	105	3	274	152	56	76	0.440	46
KX-D 95	7200	14400	3825	0-125	227	112	3	298	168	56	76	0.624	56
KX-D 105	9400	18800	3475	0-130	237	117	3	330	180	56	76	0.907	80
KX-D 120	15200	30400	3100	0-150	270	132	6	370	206	76	100	1.867	124
KX-D 135	20000	40000	2725	75-170	300	147	6	419	230	76	100	3.144	165
KX-D 150	25000	50000	2500	85-190	336	165	6	457	256	76	100	4.573	205
KX-D 170	41000	82000	2150	95-220	382	188	6	533	292	92	130	10.259	322
KX-D 190	54000	108000	1900	110-245	428	211	6	597	330	92	130	16.601	431
KX-D 215	67500	135000	1725	125-275	480	237	6	660	368	92	130	25.495	559
KX-D 240	98000	196000	1550	140-310	534	264	6	737	407	122	170	50.147	833
KX-D 265	134000	268000	1375	160-350	590	292	6	826	457	122	170	80.796	1099
KX-D 280	170000	340000	1225	180-385	628	311	6	927	508	122	170	129.979	1436
KX-D 305	205000	410000	1150	180-405	654	324	6	991	533	122	170	170.016	1669
KX-D 330	265000	530000	1075	200-435	666	330	6	1067	572	122	170	227.451	1954
KX-D 355	350000	700000	975	225-450	721	356	9	1156	610	164	220	415.259	2451
KX-D 370	430000	860000	900	225-530	773	382	9	1250	720	164	220	584.686	2925
KX-D 470	520000	1040000	855	240-520 ⁴⁾	969 ⁴⁾	480 ⁴⁾	9	1340	705 ⁴⁾	164	220	785.489	3631
KX-D 520	810000	1620000	760	240-520 ⁴⁾	1089 ⁴⁾	540 ⁴⁾	9	1540	780 ⁴⁾	164	220	1264.725	5155
KX-D 590	1000000	2000000	680	260-590 ⁴⁾	1212 ⁴⁾	600 ⁴⁾	12	1735	885 ⁴⁾	164	220	2081.885	6895
KX-D 650	1350000	2700000	610	280-650 ⁴⁾	1332 ⁴⁾	660 ⁴⁾	12	1935	975 ⁴⁾	164	220	3228.297	8893

 = Years of experience with applications at customer sites and additional test series in the KTR test field in Rheine enabled us to determine potentials allowing for an increase of the rated and maximum torques with some sizes of this series.

^{*} Drop-out center dimension required ¹⁾ Standard material Perbunan [NBR] 80 Shore A, for selection see page 18 et seq.

²⁾ Higher speeds on request. ³⁾ Referring to max. bore ⁴⁾ Variable according to customer's requests

Finish bore according to ISO fit H7, feather keyway according to DIN 6885, sheet 1 [JS9]. If requested, coupling is dynamically balanced (semi-key balancing G 6.3 with speed on request of customer). For circumferential speeds exceeding $v = 30$ m/s dyn. balancing is recommended.

 = Pilot bored available from stock

Ordering example:

REVOLEX® KX-D 170	Steel	Ø120	Ø150
Type and size of coupling	Material	Finish bore	Finish bore

POLY

REVOLEX®

REVOLEX® KX-D SB

Flexible pin & bush coupling

With brake disk

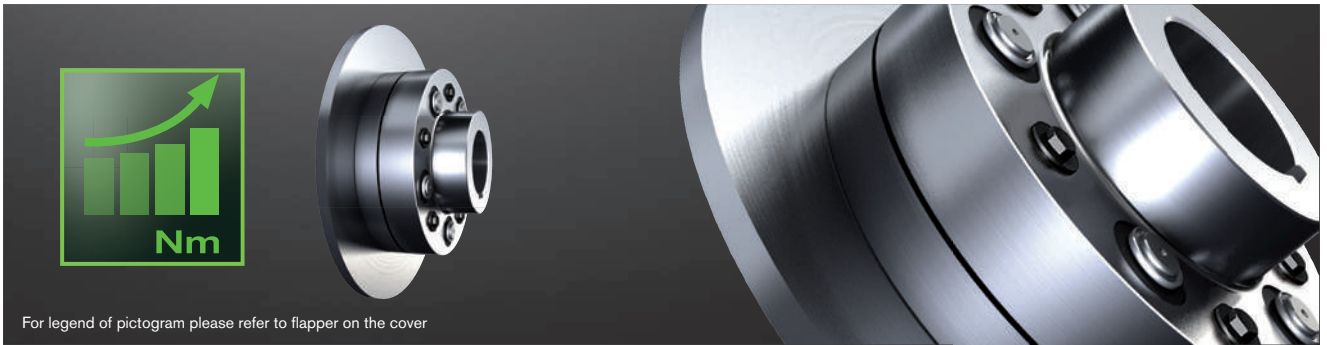

For legend of pictogram please refer to flapper on the cover



REVOLEX® KX-D Type SB

Size	Torque ¹⁾ [Nm] KX-D		Finish bore KX-D (min. - max.)		Dimensions [mm]								
	T _{KN}	T _{K max}	GJL d ₁ , d ₂	Steel d ₁ , d ₂	L	l ₁ , l ₂	E	D _H	D ₁	N ₁	N ₂	N ₃	M*
105	9400	18800	34-110	0-130	237	117	3	330	180	56	29	55	76
120	15200	30400	50-125	0-150	270	132	6	370	206	76	45	75	100
135	20000	40000	70-140	70-170	300	147	6	419	230	76	45	75	100
150	25000	50000	82-160	82-190	336	165	6	457	256	76	45	75	100
170	41000	82000	95-180	95-220	382	188	6	533	292	92	62	91	130
190	54000	108000	110-205	110-245	428	211	6	597	330	92	62	91	130
215	67500	135000	125-230	125-275	480	237	6	660	368	92	62	91	145
240	98000	196000	140-250	140-310	534	264	6	737	407	122	75	121	167

= Years of experience with applications at customer sites and additional test series in the KTR test field in Rheine enabled us to determine potentials allowing for an increase of the rated and maximum torques with some sizes of this series.

Selection of coupling/brake disk dimension N

Size	Brake disk ØA x b ²⁾					
	Ø560x30	Ø630x30	Ø710x30	Ø800x30	Ø900x30	Ø1000x30
	KX-D	KX-D	KX-D	KX-D	KX-D	KX-D
105	47	47				
120	42	42				
135		57	57			
150			75	75		
170			82	82		
190				105	105	
215				131	131	131
240				128	128	128

* Drop-out center dimension required

¹⁾ Standard material Perbunan [NBR] 80 Shore A, for selection see page 18 et seqq.

²⁾ Maximum circumferential speed v = 60 m/s referring to the maximum outside diameter.

Finish bore according to ISO fit H7, feather keyway according to DIN 6885, sheet 1 [JS9].

If requested, coupling is dynamically balanced (semi-key balancing G 6.3 with speed on request of customer). For circumferential speeds exceeding v = 30 m/s dynamic balancing is necessary (referring to outside diameter ØA).

Ordering example:

REVOLEX® KX 170	SB	Ø710 x 30	1 - Ø120	2SB - Ø150
Type and size of coupling	Type	Brake disk	Finish bore	Finish bore

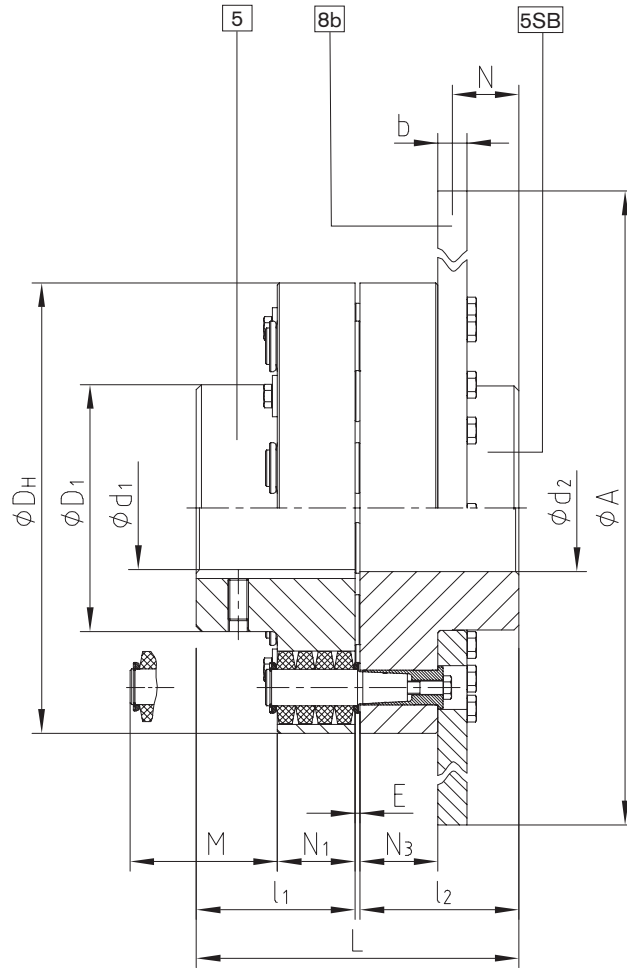

REVOLEX® KX-D with KTR 650 clamping set

Flexible pin & bush coupling

Material steel

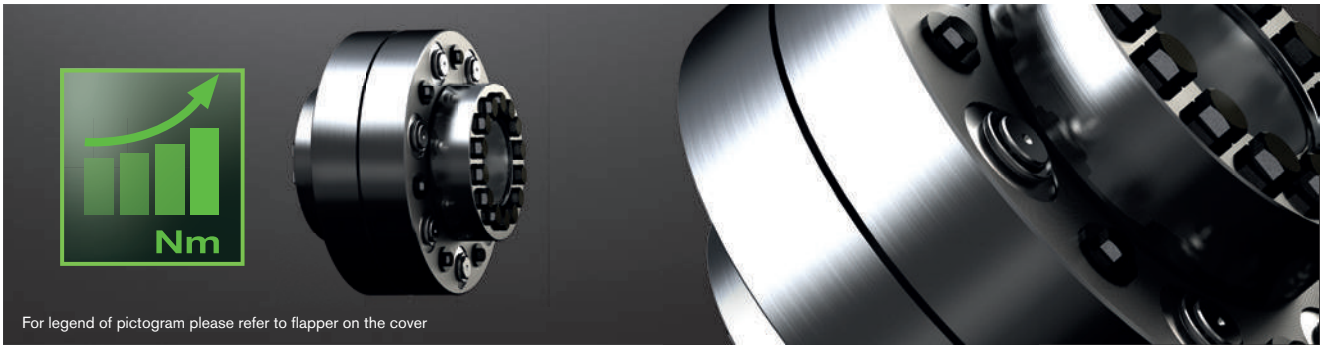

REVOLEX® KX-D						CLAMPEX® KTR 650						
Size	D _H	L ₁ /L ₂	N	E	T _{KN} ¹⁾ [Nm]	Dimensions [mm]		Screws				Transmittable torque T [Nm]
						Max. perm. size d x D	T _K	Size	Length	Quantity	T _A [Nm]	
105	330	123	56	3	9400	100 x 197	156	M16	75	14	250	18800
120	370	149	76	6	15200	110 x 215	166	M20	90	10	490	22400
135	419	157	76	6	20000	120 x 230	186	M20	90	14	490	35200
150	457	168	76	6	25000	140 x 290	216	M20	100	16	490	46700
170	533	205	92	6	41000	180 x 340	276	M24	130	16	840	85800
190	597	214	92	6	54000	220 x 405	320	M27	140	18	1250	148600
215	660	232	92	6	67500	260 x 460	356	M27	160	21	1250	192900
240	737	254	122	6	98000	240 x 430	340	M27	150	20	1250	175400
265	826	280	122	6	134000	320 x 550	402	M27	180	24	1250	248900
280	927	313	122	6	170000	390 x 630	486	M30	200	24	1700	368300
305	991	321	122	6	205000	440 x 700	534	M30	220	28	1700	472100
330	1067	321	122	6	265000	440 x 700	534	M30	220	28	1700	472100

■ = Years of experience with applications at customer sites and additional test series in the KTR test field in Rheine enabled us to determine potentials allowing for an increase of the rated and maximum torques with some sizes of this series.

¹⁾ Standard material Perbunan [NBR] 80 Shore A, for selection see page 18 et seqq.

If requested, coupling is dynamically balanced (semi-key balancing G 6.3 with speed on request of customer). For circumferential speeds exceeding $v = 30$ m/s dynamic balancing is necessary (referring to outside diameter ØA).

CLAMPEX® KTR 650							
d x D	Dimensions [mm]		Screws				Transmittable
	B1/B2	T _K	Size	Length	Quantity	T _A [Nm]	
100 x 215	73	166	M20	90	10	490	22400
110 x 230	81	186	M20	90	14	490	33600
120 x 290	92	216	M20	100	16	490	42100
130 x 290	92	216	M20	100	16	490	46700
140 x 320	102	234	M24	110	14	840	63600
150 x 320	102	234	M24	110	14	840	63600
160 x 340	113	276	M24	130	16	840	85800
170 x 340	113	276	M24	130	16	840	85800
180 x 370	117	290	M27	140	16	1,250	119700
190 x 370	117	290	M27	140	16	1,250	119700
200 x 405	122	320	M27	140	18	1,250	148600
210 x 405	122	320	M27	140	18	1,250	148600
220 x 430	132	340	M27	150	20	1,250	175400
230 x 430	132	340	M27	150	20	1,250	175400
240 x 460	140	356	M27	160	21	1,250	192900
250 x 460	140	356	M27	160	21	1,250	192900
260 x 485	147	360	M27	180	21	1,250	195000
270 x 485	147	360	M27	180	21	1,250	195000
280 x 520	150	380	M27	180	21	1,250	205900
290 x 520	150	380	M27	180	21	1,250	205900
300 x 550	158	402	M27	180	24	1,250	248900
310 x 550	158	402	M27	180	24	1,250	248900
320 x 570	164	424	M27	180	24	1,250	262500
330 x 570	164	424	M27	180	24	1,250	262500
340 x 610	171	454	M30	190	24	1,700	344000
350 x 610	171	454	M30	190	24	1,700	344000

Ordering example:	REVOLEX® KX-D 170	Steel	KTR 650 Ø120	KTR 650 Ø150
	Type and size of coupling	Material	KTR 650 for shaft diameter	KTR 650 for shaft diameter

Components

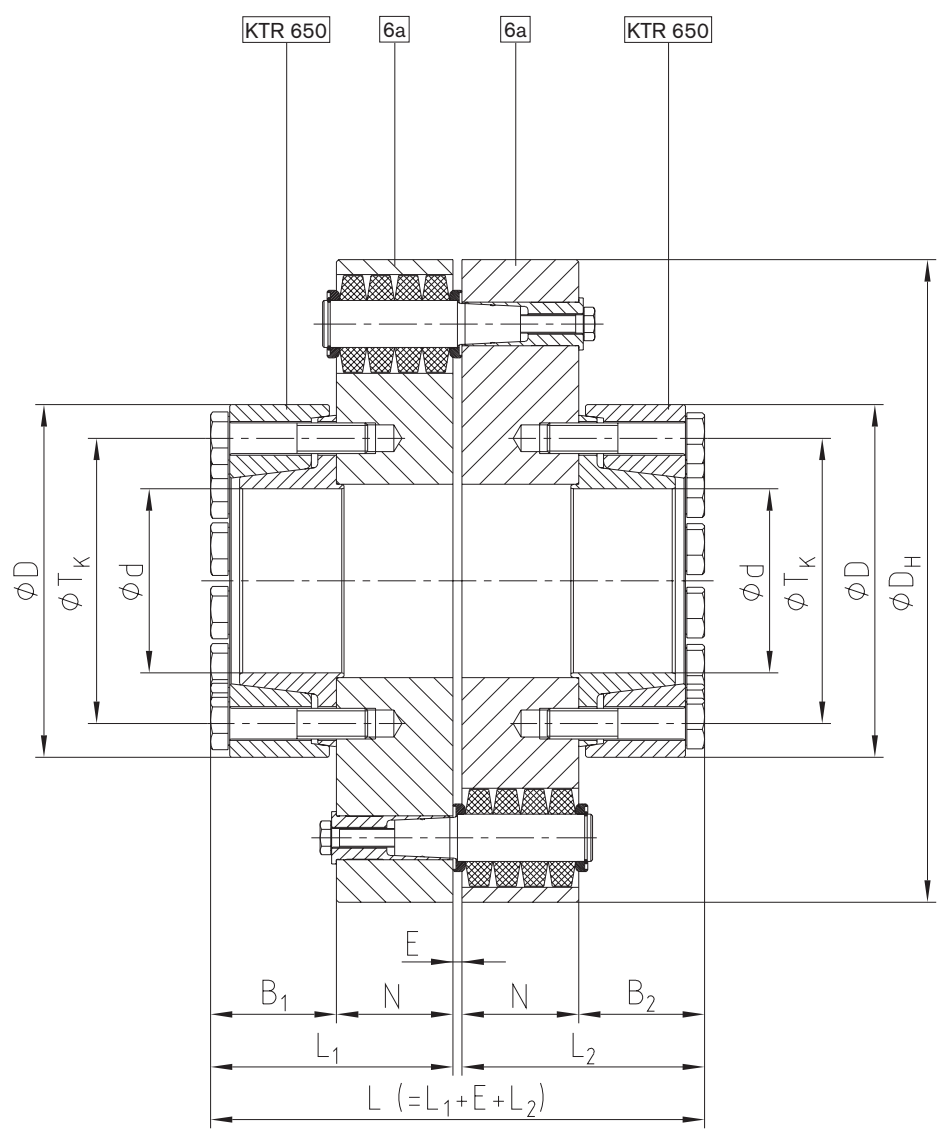

REVOLEX® KX-D

Flexible pin & bush coupling

Technical data of pins

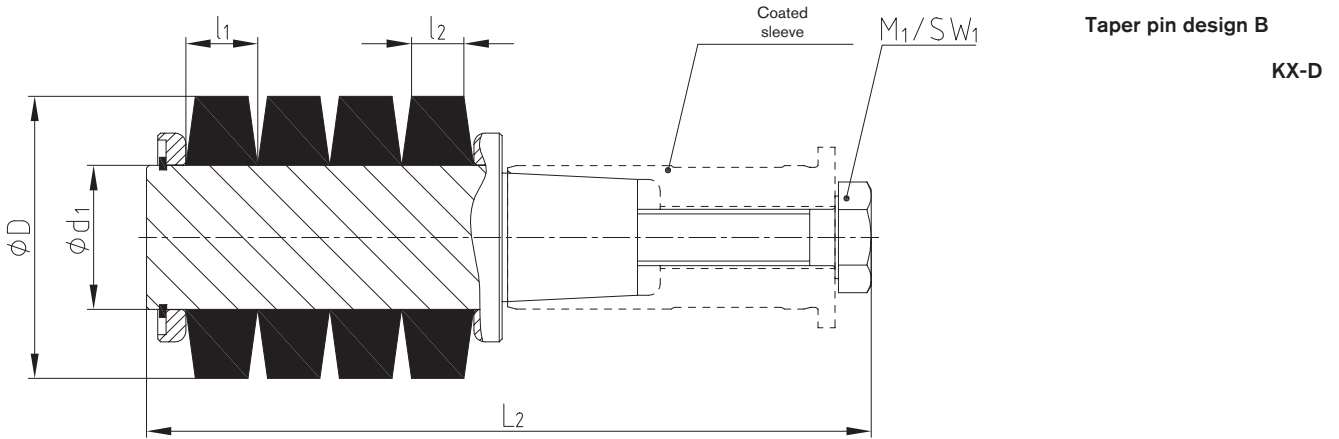

Technical data

Size	Pin		Component 3.2			Component 3.1b			Component 3.4b		Tightening torque T_A [Nm]
	Size	Quantity	Elastomer ring NBR 80 Shore A			Pin			Screw DIN EN ISO 4014/4017		
	KX-D		D	l_1	l_2	d_1	L_1	L_2	M_1	SW_1	
75	3	10									
85	3	12									
95	3	14	50.0	12.7	9.0	25.40	103	129	M10	17	67
105	3	16									
120	4	14									
135	4	16	63.0	17.8	12.5	30.60	147.5	178	M12	19	115
150	4	18									
170	5	14									
190	5	16	85.5	22.9	15.2	43.20	191	220	M16	24	290
215	5	18									
240	6	14									
265	6	16									
280	6	18	113.7	30.5	20.3	58.40	244	290	M24	36	970
305	6	20									
330	6	24									
355	7	16									
370	7	20	150	41	28	75	–	387	M30	46	1950
470	7	22									

General information on the elastomer rings

	Perbunan [NBR]	Natural rubber [NR]	Perbunan [NBR]
Material	Perbunan [NBR]	Natural rubber [NR]	Perbunan [NBR]
Hardness	80 Shore A	80 Shore A	80 Shore A
Permanent temperature range [°C]	-30 to +80	-50 to +70	-30 to +80
Max. temperature (short time) [°C]	-50 to +120	–	–
Colour	black	black	blue
Operating range	STANDARD	sub-zero temperatures	electrically insulating and backlash-free, e. g. cableway drives
			

Assembly/disassembly

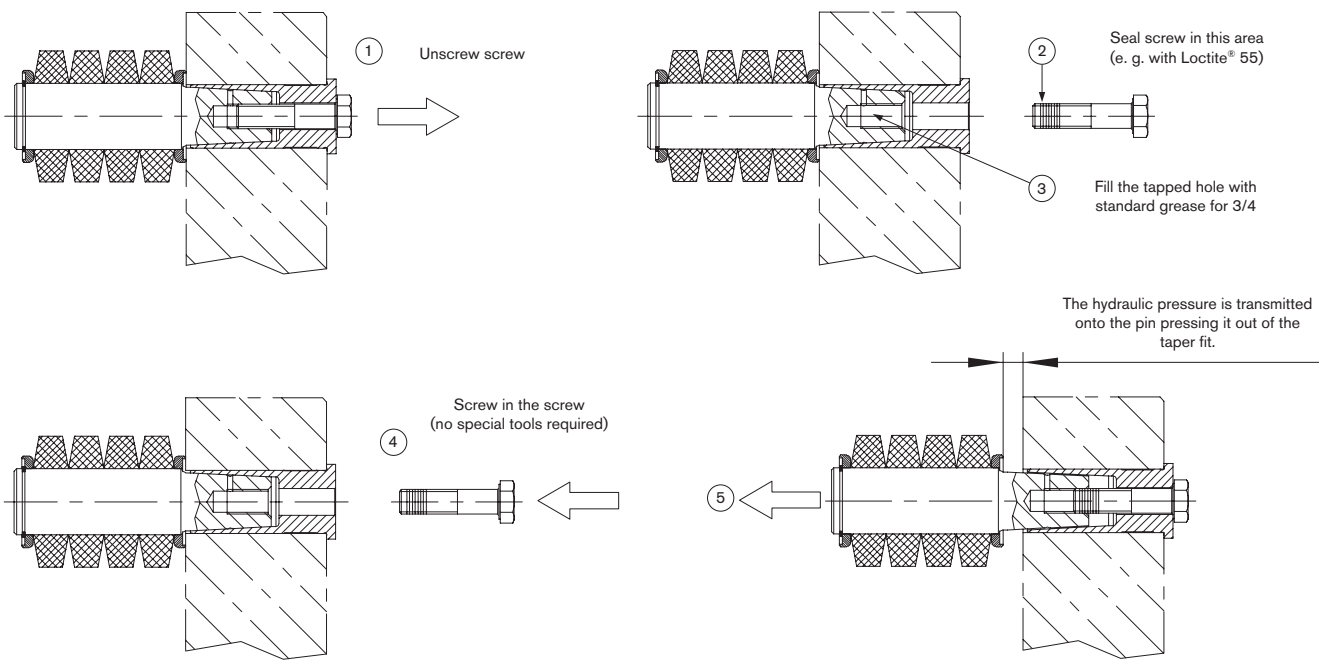

Other types

Type AB with limitation of axial backlash

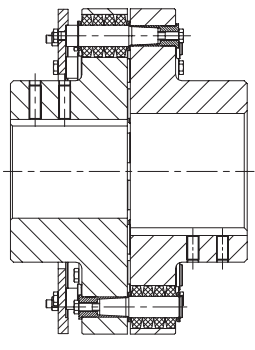

Intermediate shaft type with RADEX®-N

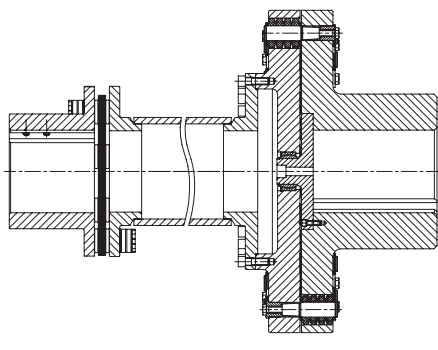

Backlash-free type

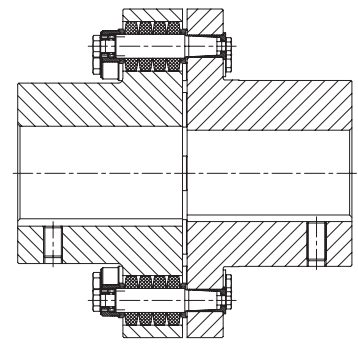

Type KX-D SD shiftable with shiftable linkage

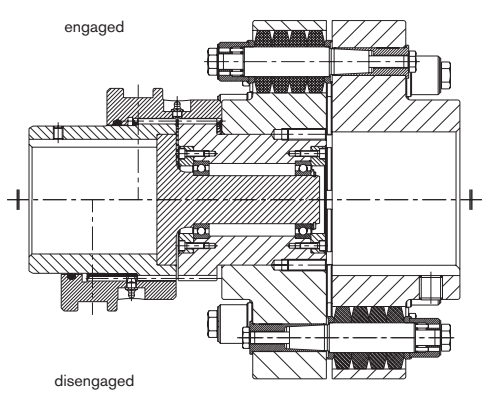

Type KX-D with cardan shaft connection

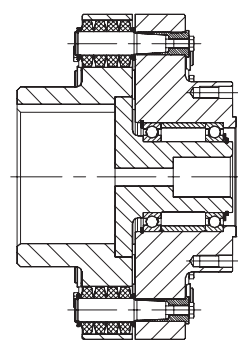

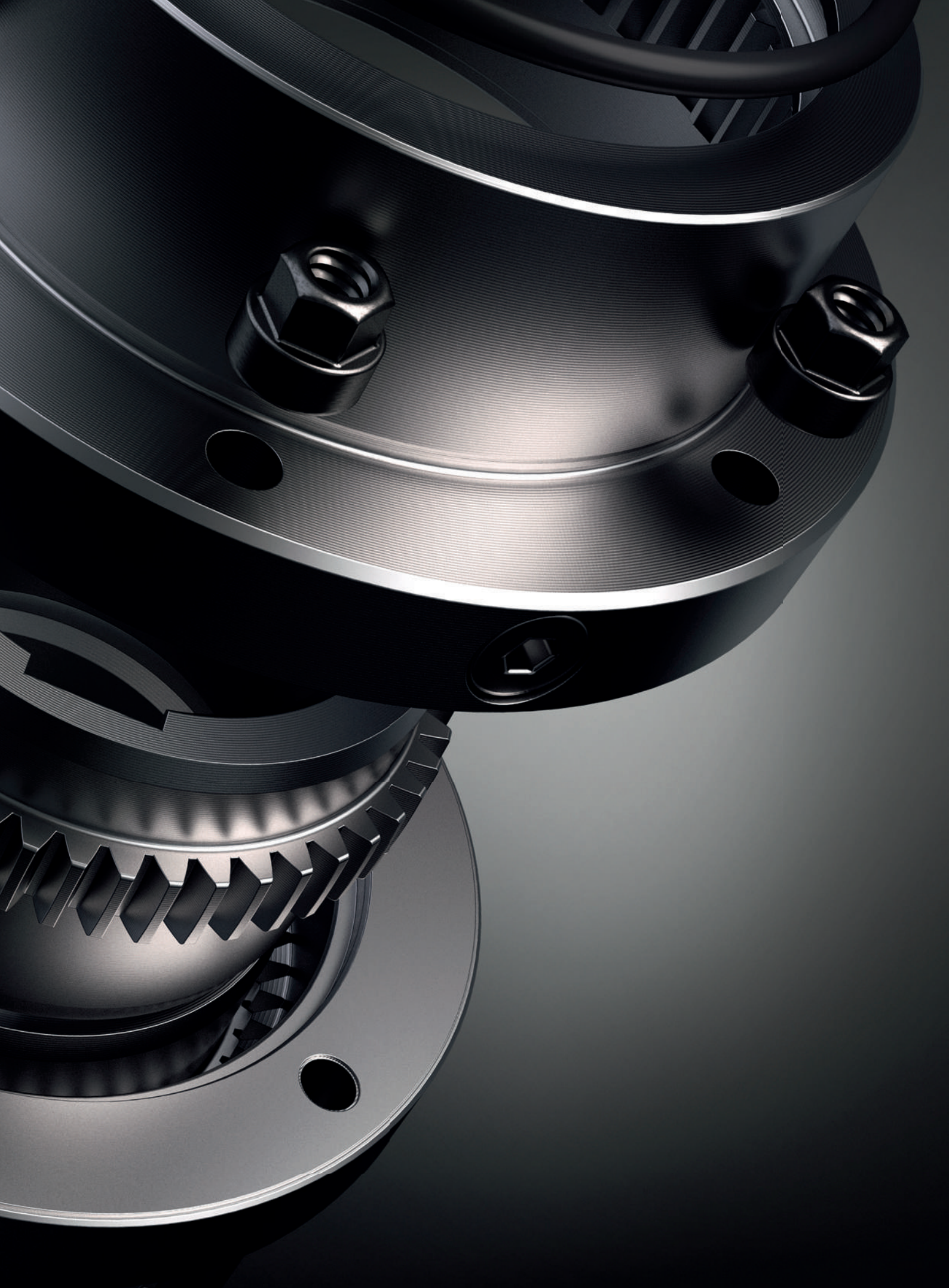

Gear couplings

Types and operating description	86
BoWex®	
Technical data	88
Displacements	89
Cylindrical and taper bores and selection of standard IEC motors	90
Type junior and junior M plug-in couplings made of nylon	91
Type M, type I and type M...C with explosion protection	92
Type AS and type Spec.-I	94
Type SG, type SSR and type Spec.-I/CD	95
Type SD / SD-D	96
Type SD1 with slip ring and shiftable linkage	98
Type GT	100
Type ZR with a long PA sleeve	101
Type HEW Compact	102
Type M made of corrosion-resistant materials	104
Taper bores	106
Spline hubs and inch bores	107
GEARex®	
Type FA, FB and FAB	108
Type DA, DB and DAB	110
Type FH and DH	112
Type FR and DR	114
Displacements	116
Flange dimensions in accordance with AGMA 9008-B00	117



Please note: torque increase



Years of experience with applications at customer sites and additional test series in the KTR test field in Rheine enabled us to determine potentials allowing for an increase of rated torques with some sizes of this series.

BoWex®



GEARex®



GEAR COUPLINGS

TYPES AND OPERATING DESCRIPTION

Properties of gear couplings

		
Product	BoWex®	GEARex®
Type	Curved-tooth gear coupling*	All-steel gear coupling
Features		
AGMA		●
Torsionally rigid	●	●
Damping vibrations	HEW Compact	
Maintenance-free	●	
Axial plug-in	●	
Compensating for misalignment	●	●
Fail-safe		●
Shear type	●	
Electric insulation	●	○
Special features		
Variation	very high extensive basic programme available from stock while customized solutions can be realized	average extensive basic programme available from stock while customized solutions can be realized
Applications / core industries	pump drives, general engineering & hydraulics, food industry, ...	heavy engineering transport, logistics, cement industry, ...
Torque range T_{KN} [Nm]		
Max.	2,500	2,750,000
Speed range n [rpm] *		
Max.	14,000	8,500
Hub materials available		
Nylon	●	
Quality steel (C45)	Size 65 - 125	up to size 85
Alloyed Q & T steel (42CrMo4V)		from size 90
powder metal steel » subject to mould	Size 14 - 65	
Stainless steel	●	
Other special materials possible	●	●
Corrosion-protected types	○	○
Sleeve (standard and special)		
Material	polyamide, polyamide with carbon fibre share, natural rubber	-
Elastomer	highly flexible	-
Temperature range [°C] min./max.		
Standard	-25/+100	-20/+80
Special	-50/+120	-40/+120

- ≈ Standard
- ≈ On request
- * ≈ Depending on size





In KTR's Power Transmission Center the performance of our products is subjected to testing. Great emphasis is put on quality assurance.

GEAR COUPLINGS

TYPES AND OPERATING DESCRIPTION

Product finder of gear couplings

Product	BoWex®	GEARex®
Type	Curved-tooth gear coupling®	All-steel gear coupling
Geometries		
Design	compact	short/compact
Mass moment of inertia	low	average
Shaft distance dimension	very low	very low
Types (extract)		
Shiftable coupling type	SD, SD-1, SD-D, SD-D3	SD
Flange type	-	FA, FB, FAB, FH, FR
Cover type	-	DA, DB, DAB, DH, DR
Suitable for horizontal assembly	Standard	Standard
Suitable for vertical assembly	Standard	VD
Sleeve can be disassembled radially » with no need of displacing driving/driven side	GT	-
Intermediate shaft types » bridging larger shaft distances	junior plug-in coupling, ZR	FH, DH
Single-cardanic	junior plug-in coupling, HEW Compact	FR, DR
Double-cardanic » compensating for big displacements » lower restoring forces	Standard	Standard
Certifications/type examinations		
ATEX 	•	•
DNV/GL 	•	•
Bureau Veritas 	•	
ABS 		•
GOST R/GOST TR 	•	
Curved-tooth gear principle 	•	•

• ≈ Standard

Details on spline

Hub with crowned spline (BoWex® and GEARex®)

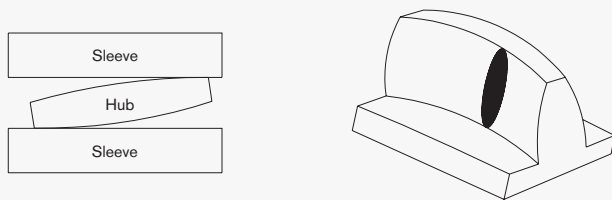

Based on the operating principle of the well-known crowned gear, edge pressure in the spline is avoided with angular and radial displacements.

BoWex®:

The smooth and hard surface of the BoWex® sleeve (crystalline structure) and the high thermal stability and resistance to lubricants, fuels, hydraulic fluids, dissolvents, etc. make polyamide an ideal material for components stressed by sliding, particularly for the coupling production.

Hub with spur toothing

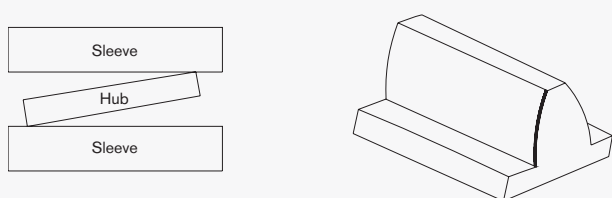

GEARex®:

In order to ensure regular and controlled lubrication in assembled condition, two connections for hydraulics are arranged opposite to each other radially on each coupling sleeve. Accordingly a complete GEARex® coupling has four connections being offset to each other by 90°.

BoWex® Curved-tooth gear coupling®

Technical data

Power, torque and speed							
Type and size		Power P [kW] / n [rpm]		Torque [Nm]			Max. speed [rpm]
		Rated	Max.	T _{KN}	T _{K max}	T _{KW}	
Type plug-in coupling/ junior M	junior 14 / M-14	0.0005	0.010	5	10	2.5	6000
	junior 19 / M-19	0.0008	0.0017	8	16	4	6000
	junior 24 / M-24	0.0013	0.0025	12	24	6	6000
Type M AS Spec.-I SG SSR	14	0.0010	0.003	10	30	5	14000
	19	0.0017	0.005	16	48	8	11800
	24	0.0021	0.006	20	60	10	10600
	28	0.0047	0.014	45	135	23	8500
	32	0.0063	0.019	60	180	30	7500
	38	0.0084	0.025	80	240	40	6700
	42	0.010	0.031	100	300	50	6000
	45 / 48	0.015	0.044	140	420	70	5600
	65	0.040	0.119	380	1140	190	4000
	80	0.073	0.22	700	2100	350	3150
	100	0.13	0.38	1200	3600	600	3000
	125	0.26	0.78	2500	7500	1250	2120
Type M...C GT	14	0.0015	0.0047	15	45	7.5	14000
	19	0.0025	0.0075	24	72	12	11800
	24	0.003	0.009	30	90	15	10600
	28	0.007	0.022	70	210	35	8500
	32	0.009	0.028	90	270	45	7500
	38	0.013	0.038	120	360	60	6700
	48	0.021	0.063	200	600	100	5600
	65	0.058	0.18	560	1680	280	4000
Type HEW Compact	T50 Sh	0.0236	0.0471	200	400	50	7300
	42-130 T65 Sh	0.0283	0.0565	270	540	68	7300
	T70 Sh	0.0330	0.0660	320	640	80	7300
	T50 Sh	0.0628	0.1257	550	1100	138	5500
	65-180 T65 Sh	0.0785	0.1571	740	1500	185	5500
	T70 Sh	0.0890	0.1780	860	1700	215	5500
	T50 Sh	0.1414	0.2827	1250	2500	313	4400
	80-225 T65 Sh	0.1728	0.3455	1600	3200	400	4400
	T70 Sh	0.2042	0.4084	1900	3800	475	4400
	T50 Sh	0.3141	0.6283	2750	5500	688	3200
	100-305 T65 Sh	0.4084	0.8168	3900	7800	975	3200
	T70 Sh	0.4712	0.9424	4500	9000	1125	3200
	T50 Sh	0.6283	1.2565	5500	11000	1375	2900
	125-365 T65 Sh	0.7853	1.5707	7500	15000	1875	2900
	T70 Sh	0.8901	1.7801	8400	16800	2100	2900

Thread for setscrews

Thread dimensions for setscrews, BoWex® coupling hubs with cylindrical bore.

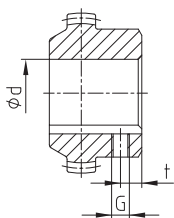

Position of the thread for setscrews BoWex® M-14 to M-24 opposite the keyway

BoWex® M-28 to I-125 on the keyway

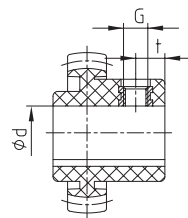

Position of thread with BoWex® junior plug-in coupling and junior M coupling

BoWex® coupling hubs							
Size Dimensions	14 19 24	28 32 38	42 45 48	65	80	100	125
Thread G	M5	M8	M10	M10	M12	M16	
Distance t	6	10	15 ¹⁾ 20	20	30	40	
Tightening torque T _A [Nm]	2	10	17	17	40	80	

BoWex® junior coupling hubs			
Size Dimensions	14	19	24
Thread G	M5	M5	M5
Hub 1b - Distance t	6	6	6
Plug-in sleeve 2b - Distance t	8	10	10
Tightening torque T _A [Nm]	1.4	1.4	1.4

¹⁾ Length of hub 55 mm t = 15 mm, 70 mm t = 20 mm

BoWex® Curved-tooth gear coupling®

Types of hubs

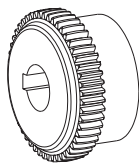

Type 1.0 hub with feather keyway and setscrew

Positive-locking power transmission, permissible torque depending on the permissible surface pressure. Not suitable for backlash-free power transmission with heavily reversing operation.

Type 1.1 hub without feather key with setscrew

Non-positive torque transmission for crimp connections and adhesive bonds. (No ATEX approval)

Type 1.3 hub with spline bore (see page 107)

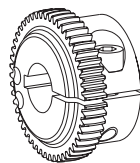

Type 2.0 clamping hub single slot without feather keyway

Frictionally engaged, backlash-free shaft-hub-connection. Transmittable torques depending on bore diameter.

Type 2.1 clamping hub single slot with feather keyway

Positive-locking power transmission with additional friction fit. The friction fit avoids or reduces reverse backlash. Surface pressure of the keyway connection is reduced.

Type 2.3 clamping hub with spline bore (see page 107)

Displacements

BoWex® couplings are double-cardanic compensating for axial, radial and angular shaft displacements in addition to transmitting the torque so that damage on the driving or driven machine is prevented.

Axial displacement

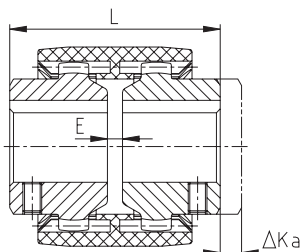

Radial displacement

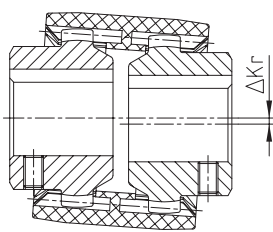

Angular displacement

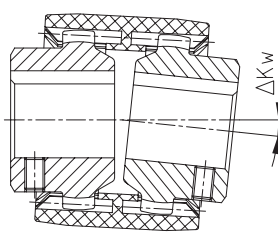

Radial and angular displacement

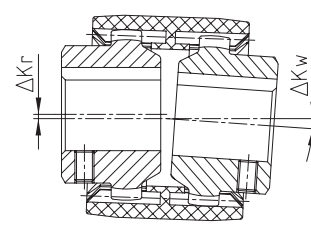

Displacements – type junior couplings

BoWex® size	Type junior plug-in coupling			Type junior M		
	14	19	24	14	19	24
Max. axial displacement ΔK_a [mm]	± 1	± 1	± 1	± 1	± 1	± 1
Max. radial displacement with $n=1500$ rpm ΔK_r [mm]	± 0.1	± 0.1	± 0.1	± 0.3	± 0.3	± 0.4
Max. radial displacement with $n=3000$ rpm ΔK_r [mm]	± 0.1	± 0.1	± 0.1	± 0.3	± 0.3	± 0.4
Max. angular displacement with $n=1500$ rpm ΔK_w [degree]	± 1.0	± 1.0	± 0.9	± 1.0	± 1.0	± 0.9
Max. angular displacement with $n=3000$ rpm ΔK_w [degree]	± 0.7	± 0.7	± 0.6	± 0.7	± 0.7	± 0.6

Displacements – type M, I, AS, Spec.-I, SG and SSR

BoWex® size	14	19	24	28	32	38	42	48	65	80	100	125
Max. axial displacement ΔK_a [mm]	± 1	± 1	± 1	± 1	± 1	± 1	± 1	± 1	± 1	± 1	± 1	± 1
Max. radial displacement with $n=1500$ rpm ΔK_r [mm]	± 0.30	± 0.30	± 0.35	± 0.35	± 0.35	± 0.40	± 0.40	± 0.40	± 0.45	± 0.45	± 0.45	± 0.45
Max. radial displacement with $n=3000$ rpm ΔK_r [mm]	± 0.20	± 0.20	± 0.23	± 0.23	± 0.23	± 0.25	± 0.25	± 0.25	± 0.28	± 0.28	± 0.28	± 0.28
Max. angular displacement with $n=1500$ rpm ΔK_w [degree]	± 1.0	± 1.0	± 0.9	± 0.9	± 0.9	± 0.9	± 0.9	± 0.9	± 0.7	± 0.6	± 0.6	± 0.4
Max. angular displacement with $n=3000$ rpm ΔK_w [degree]	± 0.7	± 0.7	± 0.6	± 0.6	± 0.6	± 0.6	± 0.6	± 0.6	± 0.5	± 0.4	± 0.4	± 0.3

Displacements – Type GT

Displacements – Type HEW Compact

BoWex® size	Type GT				Type HEW Compact														
	28	38	48	65	42-130			65-180			80-225			100-305			125-365		
					T50	T65	T70	T50	T65	T70	T50	T65	T70	T50	T65	T70	T40	T52	T65
Max. axial displacement ΔK_a [mm]	± 1	± 1	± 1	± 1	± 2			± 2			± 2			± 2			± 2		
Max. radial displacement with $n=1500$ rpm ΔK_r [mm]	± 1	± 1	± 1.4	± 1.4	± 1.1	± 1	± 0.5	± 1.6	± 1.5	± 0.7	± 1.8	± 1.7	± 2.2	± 2.2	± 2	± 1	± 2.5	± 2.3	± 1.1
Max. radial displacement with $n=3000$ rpm ΔK_r [mm]	± 0.6	± 0.6	± 1	± 1	± 0.55	± 0.5	± 0.25	± 0.8	± 0.75	± 0.35	± 0.9	± 0.85	± 1.1	± 1.1	± 1	± 0.5	± 1.25	± 1.15	± 0.55
Max. angular displacement with $n=1500$ rpm ΔK_w [degree]	± 1	± 1	± 0.9	± 0.9	± 1	± 0.75	± 0.5	± 1	± 0.75	± 0.5	± 1	± 0.75	± 1	± 1	± 0.75	± 0.5	± 1	± 0.75	± 0.5
Max. angular displacement with $n=3000$ rpm ΔK_w [degree]	± 0.7	± 0.7	± 0.6	± 0.6	± 0.5	± 0.4	± 0.25	± 0.5	± 0.4	± 0.25	± 0.5	± 0.4	± 0.25	± 0.5	± 0.25	± 0.25	± 0.5	± 0.4	± 0.25

The permissible displacement figures of the BoWex® couplings specified are general standard values taking into account the load of the coupling up to the rated torque T_{KN} of the coupling. With different operating conditions please order our data sheet for displacements of BoWex® KTR-N 20140. The displacement figures may only be used one by one, if they appear simultaneously, they must be limited in proportion. Care should be taken to maintain the distance dimension E accurately in order to allow for axial clearance of the coupling while in operation. Detailed mounting instructions are shown on our homepage www.ktr.com.

BoWex® Curved-tooth gear coupling®

Cylindrical bores, taper/inch bores see selection of standard IEC motors

Stock programme of cylindrical finish bores [mm] H7 feather keyway acc. to DIN 6885 sheet 1 [JS9] and thread for setscrews																														
BoWex® Size	un/pilot bored	Ø8	Ø10	Ø11	Ø12	Ø14	Ø15	Ø16	Ø17	Ø18	Ø19	Ø20	Ø22	Ø24	Ø25	Ø28	Ø30	Ø32	Ø35	Ø38	Ø40	Ø42	Ø45	Ø48	Ø50	Ø55	Ø60	Ø65	Ø70	Ø75
14	●■	●	●	●	●	●	●																							
19	●■		●	●	●	●	●	●	●	●	●■	●																		
24	●■		●	●	●	●■	●	●	●	●	●■	●■	●	●■	●															
28	●■				●	●	●	●	●	●	●	●	●	●	●	●■														
32	●■							●		●	●	●	●	●	●	●	●	●	●											
38	●■							●		●	●	●	●	●	●	●	●	●	●	●■										
42	●■									●	●	●	●	●	●	●	●	●	●	●	●	●	●	●	●					
48	●■										●	●	●	●	●	●	●	●	●	●	●	●	●■	●■	●■					
65	●■											●	●	●	●	●	●	●	●	●	●	●■	●■	●■	●■	●■	●■	●■	●■	●■
80	●																						●	●	●	●	●	●	●	

● Standard length ■ Standard lengthened

Stock programme taper and inch bores																				
Code d +0.05 b JS9 t +0.2	Taper 1:5					Taper 1:8					Inch bores									
	A-10 9.85 2	B-17 16.85 3	C-20 19.85 4	D-25 24.85 5	E-30 29.85 6	N/1 9.7 2.4	N1d 14 3	N/2 17.28 3.2	N/2a 17.28 4	N/3 22 3.99	Ta 12.7 3.17 14.3	DNC 13.45 3.17 14.9	Ed 15.87 4.75 18.1	A 19.05 4.78 21.3	G 22.22 4.75 24.7	F 22.22 6.38 25.2	Bs 25.38 6.37 28.3	Hs 25.4 6.35 28.7	K 31.75 7.93 35.4	
14	●						●												●	
19		●					●												●	
24	●	●					●		●	●		●							●	●
28	●	●					●	●	●	●		●							●	
32		●																		
38		●							●	●									●	
42		●		●					●	●		●						●	●	
48									●	●		●								
65																				●

Other dimensions on request.

BoWex® couplings for standard IEC motors, protection class IP 54/IP 55										
A. C. motor Size	Motor power with 50 Hz n = 3000 [rpm]			Motor power with 50 Hz n = 1500 [rpm]			Motor power with 50 Hz n = 1000 [rpm]			Cylindrical shaft ends d x l [mm] 3000 ≤ 1500
	kW	T [Nm]	BoWex® coupling	kW	T [Nm]	BoWex® coupling	kW	T [Nm]	BoWex® coupling	
56	0.09	0.32		0.06	0.43		0.037	0.43		9 x 20
	0.12	0.41		0.09	0.64		0.045	0.52		
63	0.18	0.62	14	0.12	0.88	14	0.06	0.72	14	11 x 23
	0.25	0.86		0.18	1.3		0.09	1.1		
71	0.37	1.3	19	0.25	1.8	19	0.18	2.0	19	14 x 30
	0.55	1.9		0.37	2.5		0.25	2.7		
80	0.75	2.5	24	0.55	3.7	24	0.37	3.9	24	19 x 40
	1.1	3.7		0.75	5.1		0.55	5.8		
90 S	1.5	5.0	28	1.1	7.5	28	0.75	8.0	28	24 x 50
90 L	2.2	7.4		1.5	10		1.1	12		
100 L	3	9.8	38	2.2	15	38	1.5	15	38	28 x 60
				3	20		2.2	22		
112 M	4	13	42	4	27	42	2.2	22	42	38 x 80
132 S	5.5	18		5.5	36		3	30		
	132 M	7.5	25	7.5	49	4	40	5.5	55	
160 M	11	36	48	11	72	48	7.5	75	48	42 x 110
	15	49		15	98		11	108		
160 L	18.5	60	65	18.5	121	65	15	148	65	48 x 110
180 M	22	71		22	144		15	148		
180 L			80			80	18.5	181	80	55 x 110
200 L	30	97		30	196		22	215		
225 S			100	37	240	100			100	55 x 110 60 x 140
225 M	45	145		45	292		30	293		
250 M	55	177	125	55	356	125	37	361	125	60 x 140 65 x 140
280 S	75	241		75	484		45	438		
280 M	90	289	150	90	581	150	55	535	150	75 x 140
315 S	110	353		110	707		75	727		
315 M	132	423	175	132	849	175	90	873	175	80 x 170
	160	513		160	1030		110	1070		
315 L	200	641	200	200	1290	200	132	1280	200	65 x 140
				160	1550		160	1550		
315	250	801	250	250	1610	250	200	1930	250	85 x 170
	315	1010		315	2020		250	2420		
355	355	1140	315	355	2280	315			315	75 x 140 95 x 170
	400	1280		400	2560		315	3040		

Torque T ^Δ = rated torque according to Siemens catalogue.

BoWex® junior and junior M Curved-tooth gear coupling®

Plug-in coupling made of nylon (two-part and three-part)



For legend of pictogram please refer to flapper on the cover

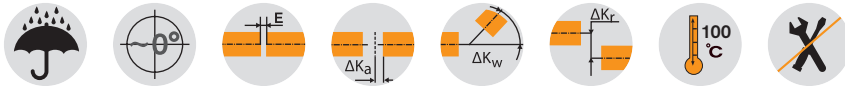

Components

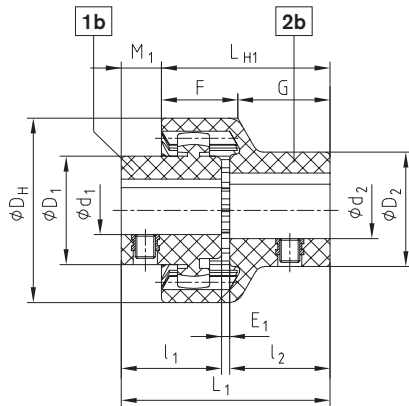

Type junior plug-in coupling (two-part)

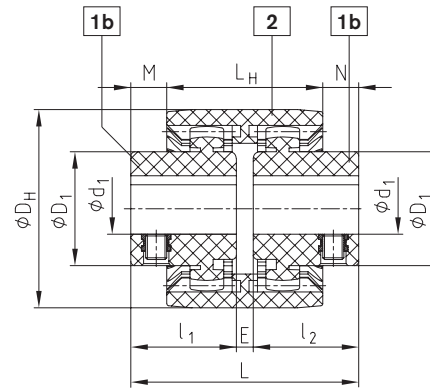

Type junior M coupling (three-part)

BoWex® junior plug-in coupling (two-part) and BoWex® junior M (three-part)																			
Size	Torque [Nm]		Finish bore				Dimensions [mm]										Max. speed [rpm]		
			Hub Component 1b ¹⁾		Plug-in sleeve Component 2b ¹⁾		DH	l ₁ , l ₂	E ₁	L ₁	L _{H1}	M ₁	F	G	E	L		L _H	M, N
	d ₁ ¹⁾	D ₁	d ₂ ¹⁾	D ₂															
14 M-14	5	10	Ø6, Ø7,	22	Ø8	22	40	23	2	48	40	8	18.5	21.5	4	50	37	6.5	6000
Ø8, Ø9			25	Ø10, Ø11	25														
Ø10, Ø11			26	Ø12, Ø14	26														
19 M-19	8	16	Ø12, Ø14	27	Ø14, Ø15	29	47	25	2	52	42	10	19.0	23.0	4	54	37	8.5	6000
Ø16			30	Ø19	35														
Ø19			32																
24 M-24	12	24	Ø10, Ø11,	26	Ø14, Ø16	32	53	26	2	54	45	9	21.5	23.5	4	56	41	7.5	6000
Ø12																			
Ø14, Ø15,			32																
Ø16																			
			Ø18, Ø19,	36	Ø19, Ø20	36													
			Ø20																
			Ø24	38	Ø24	40													

¹⁾ Finish bore with tolerance +0.05/-0.1; feather keyway ±0.08

Ordering example:	BoWex® junior 19	d ₁ Ø19	d ₂ Ø14
	Coupling size two-part type or BoWex® junior M-19 three-part type	Finish bore	Finish bore

BoWex® M, I Curved-tooth gear coupling®

Compact and maintenance-free



For legend of pictogram please refer to flapper on the cover

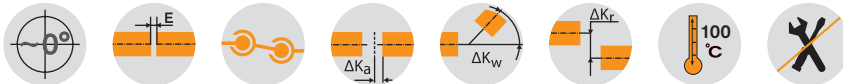

Components

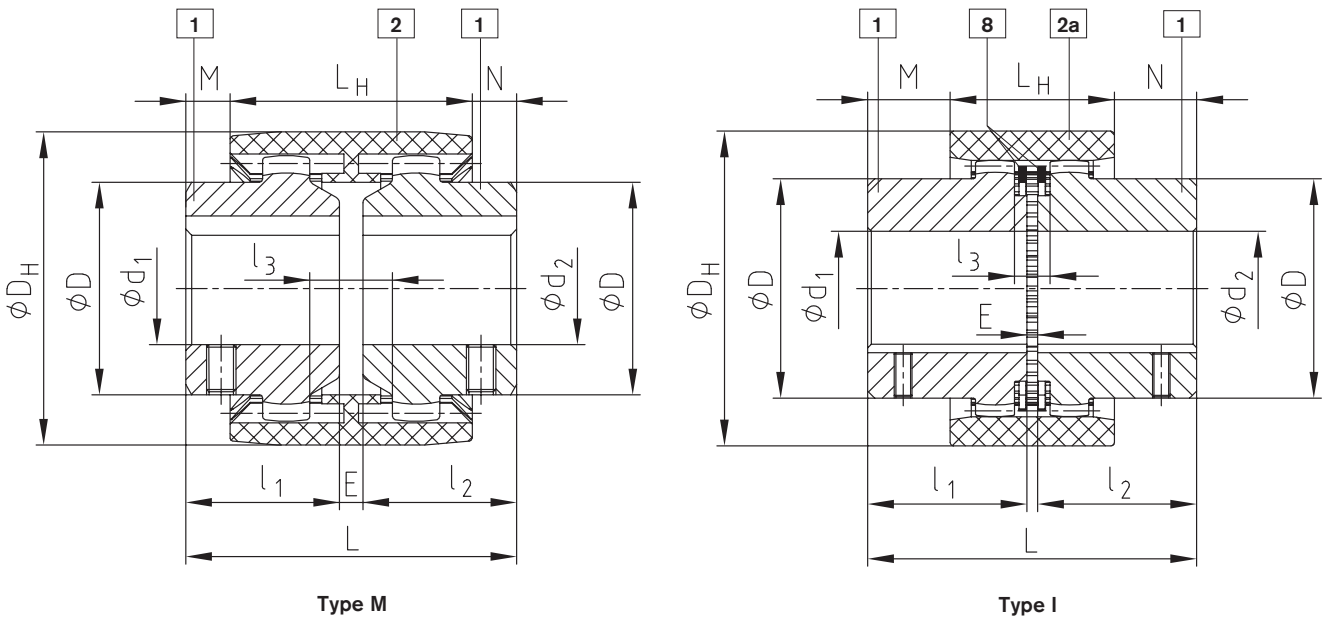

BoWex® type M, type I																								
Size	Torque [Nm]			Finish bore d1, d2		Dimensions [mm]													Weight with max. bore [kg]			Mass moment of inertia J with max. bore [kgcm ²]		
	T _{KN}	T _{K max}	T _{KW}	Pilot bored	Max.	l ₁ , l ₂	E	L	L _H	M, N	l ₃	D	D _H	Tip circle ØD _Z hub	Number of teeth	Hub lengthened max. l ₁ , l ₂	Sleeve	Hub	Total	Sleeve	Hub	Total		
M-14	10	30	5	-	15	23	4	50	37	6.5	10	25	40	33	20	40	0.03	0.07	0.1	0.08	0.09	0.26		
M-19	16	48	8	-	20	25	4	54	37	8.5	10	32	47	39	24	40	0.03	0.1	0.23	0.15	0.16	0.47		
M-24	20	60	10	-	24	26	4	56	41	7.5	14	36	53	45	28	50	0.04	0.14	0.32	0.21	0.36	0.93		
M-28	45	135	23	-	28	40	4	84	46	19	13	44	65	54	34	55	0.08	0.33	0.74	0.65	1.22	3.09		
M-32	60	180	30	-	32	40	4	84	48	18	13	50	75	63	40	55	0.09	0.43	0.95	1.14	2.17	5.48		
M-38	80	240	40	-	38	40	4	84	48	18	13	58	83	69	44	60	0.13	0.55	1.23	1.58	3.55	8.68		
M-42	100	300	50	-	42	42	4	88	50	19	13	65	92	78	50	60	0.14	0.68	1.5	2.32	5.98	14.28		
M-48	140	420	70	-	48	50	4	104	50	27	13	68	95	78	50	60	0.23	0.79	1.81	3.9	7.22	18.34		
M-65	380	1140	190	21	65	55	4	114	68	23	16	96	132	110	42	70	0.55	1.9	4.35	21.2	31.8	84.8		
I-80	700	2100	350	31	90	90	6	186	93	46.5	20	124	178	145	46	-	1.13	5.2	11.53	68.9	150.8	370.5		
I-100	1200	3600	600	38	100	110	8	228	102	63	22	152	210	176	48	-	1.78	9.37	20.52	158.6	401.3	961.2		
I-125	2500	7500	1250	45	125	140	10	290	134	78	30	192	270	225	54	-	3.88	19.44	42.76	562.9	1362.3	3287.5		

Ordering example:	BoWex® M-28	d ₁ Ø20	d ₂ Ø28
	Size and type of coupling	Finish bore H7 keyway to DIN 6885 sheet 1 (JS9)	Finish bore H7 keyway to DIN 6885 sheet 1 (JS9)

BoWex® M...C Curved-tooth gear coupling®

Compact and maintenance-free



For legend of pictogram please refer to flapper on the cover

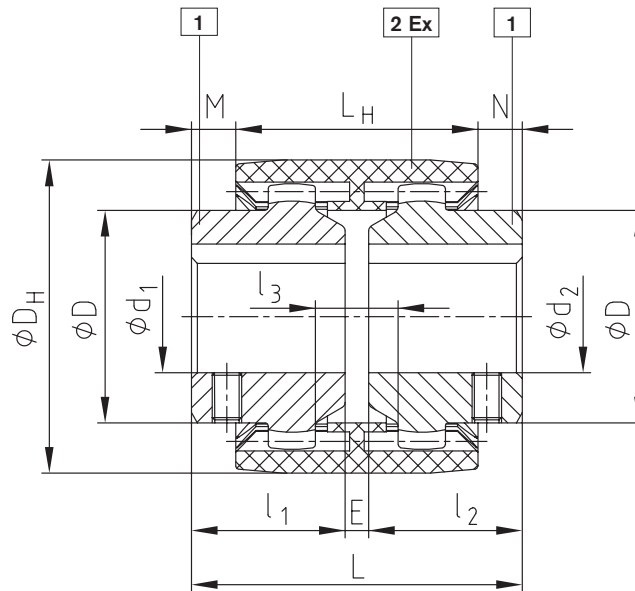
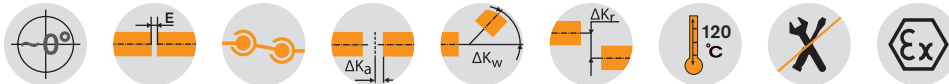

Type M...C

BoWex® Type M...C																								
Size	Torque [Nm]			Finish bore d1, d2		Dimensions [mm]													Weight with max. bore [kg]			Mass moment of inertia J with max. bore [kgcm ²]		
	T _{KN}	T _{K max}	T _{KW}	Pilot bored	Max.	l ₁ , l ₂	E	L	L _H	M, N	l ₃	D	D _H	Tip circle ØDz hub	Number of teeth	Hub lengthened max. l ₁ , l ₂	Sleeve	Hub	Total	Sleeve	Hub	Total		
M-14C	15	45	7,5	-	15	23	4	50	37	6,5	10	25	40	33	20	40	0,03	0,07	0,1	0,08	0,09	0,26		
M-19C	24	72	12	-	20	25	4	54	37	8,5	10	32	47	39	24	40	0,03	0,1	0,23	0,15	0,16	0,47		
M-24C	30	90	15	-	24	26	4	56	41	7,5	14	36	53	45	28	50	0,04	0,14	0,32	0,21	0,36	0,93		
M-28C	70	210	35	-	28	40	4	84	46	19	13	44	65	54	34	55	0,08	0,33	0,74	0,65	1,22	3,09		
M-32C	90	270	45	-	32	40	4	84	48	18	13	50	75	63	40	55	0,09	0,43	0,95	1,14	2,17	5,48		
M-38C	120	360	60	-	38	40	4	84	48	18	13	58	83	69	44	60	0,13	0,55	1,23	1,58	3,55	8,68		
M-48C	200	600	100	-	48	50	4	104	50	27	13	68	95	78	50	60	0,23	0,79	1,81	3,9	7,22	18,34		
M-65C	560	1680	280	21	65	55	4	114	68	23	16	96	132	110	42	70	0,55	1,9	4,35	21,2	31,8	84,8		
M-80C	1000	3000	500	31	90	90	6	186	93	46,5	20	124	178	145	46	-	1,13	5,2	11,53	68,9	150,8	370,5		

Ordering example:	BoWex® M-28C	d ₁ Ø20	d ₂ Ø28
	Size and type of coupling	Finish bore H7 keyway to DIN 6885 sheet 1 (JS9)	Finish bore H7 keyway to DIN 6885 sheet 1 (JS9)

BoWex® AS and Spec.-I Curved-tooth gear coupling®

Compact and maintenance-free

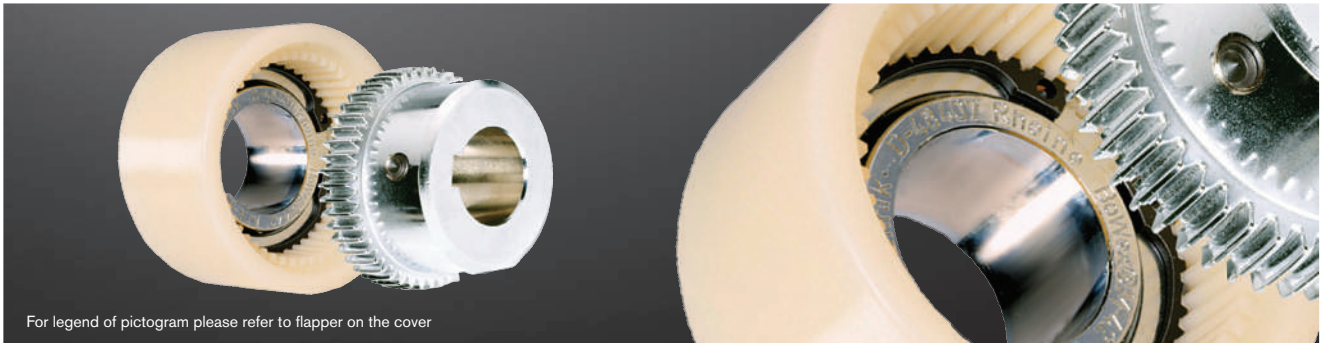

For legend of pictogram please refer to flapper on the cover

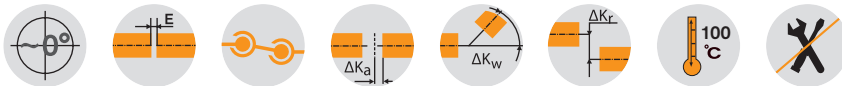

Components

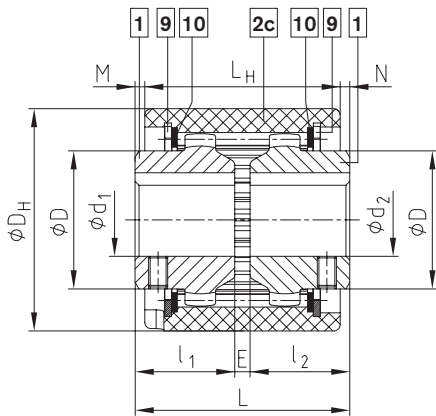

Type AS

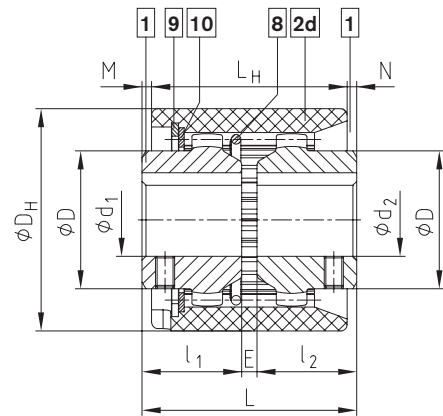

Type Spec.-I

BoWex® Type AS and type Spec.-I																		
Size	Pilot bore		Finish bore d ₁ , d ₂	Dimensions [mm]									Weight with max. bore [kg]			Mass moment of inertia J with max. bore [kgcm ²]		
	Unbored	Pilot bored		Max.	l ₁ , l ₂	E	L	L _H	M, N	D	D _H	Hub length max. l ₁ , l ₂	Sleeve	Hub	Total	Sleeve	Hub	Total
24	x	-	For finish bores see stock programme	24	26	4	56	51	2.5	36	58	50	0.11	0.14	0.39	0.38	0.36	1.10
28	x	-		28	40	4	84	56	14	44	70	55	0.16	0.33	0.82	1.54	1.22	3.98
32	x	-		32	40	4	84	58	13	50	84	55	0.21	0.43	1.07	2.75	2.17	7.09
45	x	-		45	42	4	88	60	14	65	100	60	0.27	0.63	1.53	5.49	5.66	16.81
65	-	21		65	55	4	114	84	15	96	140	70	0.84	2.10	5.00	29.83	43.96	117.8
80	-	31		90	90	6	186	93	46.5	124	178	-	1.30	5.20	11.70	83.20	150.8	384.8
100	-	38		100	110	8	228	102	63	152	210	-	2.05	9.40	20.80	184.4	401.3	987.0
125	-	45	125	140	10	290	134	78	192	270	-	4.32	19.44	43.10	620.0	1362.3	3344.6	

For performance data see page 88.

Ordering example:	BoWex® 32 AS	d ₁ Ø32	d ₂ Ø32
	Size and type of coupling AS or Spec.-I	Finish bore H7 keyway to DIN 6885 sheet 1 (JS9)	Finish bore H7 keyway to DIN 6885 sheet 1 (JS9)

BoWex® SG, SSR and Spec.-I/CD Curved-tooth gear coupling®

Type with dust protection



For legend of pictogram please refer to flapper on the cover

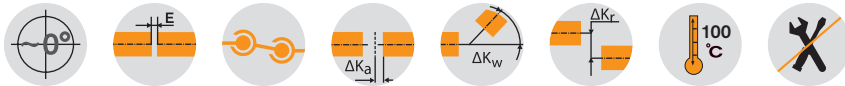

BoWex® Type SG with dust protection circlips												
Size	Pilot bore		Finish bore		Dimensions [mm]							
	Unbored	Pilot bored	Min.	Max.	l_1, l_2	E	L	L_H	M, N	D	D_H	Hub length. max. l_1, l_2
24 SG	x	-	10	24	36	4	76	51	12.5	36	58	50
28 SG	x	-	10	28	40	4	84	56	14	44	70	55
32 SG	x	-	12	32	40	4	84	58	13	50	84	55
45 SG	x	-	20	45	42	4	88	60	14	65	100	60
65 SG	-	21	30	65	70	4	144	84	30	96	140	-
80 SG	-	31	35	90	90	6	186	93	46.5	122	175	-
100 SG	-	38	40	100	110	8	228	102	63	150	210	-
125 SG	-	45	50	125	140	10	290	134	78	190	270	-

Thread for setscrews with finish bored hubs only.



BoWex® Type SSR with Seeger circlips												
Size	Pilot bore		Finish bore		Dimensions [mm]							
	Unbored	Pilot bored	Min.	Max.	l_1, l_2	E	L	L_H	M, N	D	D_H	Hub length. max. l_1, l_2
24 SSR	x	-	10	22	26	4	56	51	2.5	35	58	50
28 SSR	x	-	10	26	40	4	84	56	14	42	70	55
32 SSR	x	-	12	30	40	4	84	58	13	48	84	55
45 SSR	x	-	20	42	42	4	88	60	14	63	100	60
65 SSR	-	21	30	65	55	4	114	84	15	95	140	70
80 SSR	-	31	35	90	90	6	186	93	46.5	120	175	-
100 SSR	-	38	40	100	110	8	228	102	63	150	210	-
125 SSR	-	45	50	125	140	10	290	134	78	190	270	-

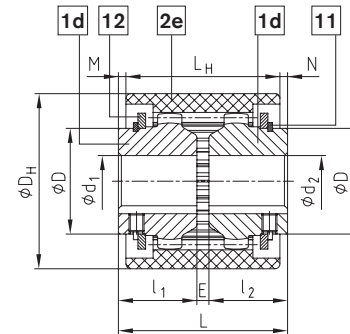

BoWex® Type Spec.-I/CD															
Size	Pilot bore		Finish bore		Dimensions [mm]										
	Unbored	Pilot bored	Min.	Max.	L	L_1	L_H	E	E_1	l_2	l_1	D_H	D	M	N
24 CD	x	-	10	24	70	73.5	51	4	9.0	26	40	58	36	20	2.5
28 CD	x	-	10	28	94.5	98	56	4	8.5	40	50.5	70	44	28	14
32 CD	x	-	12	32	94.5	-	58	4	8.5	40	50.5	84	50	27	13
45 CD	x	-	20	45	101.5	-	60	4	8.5	42	55.5	100	65	32	14
65 CD	-	21	30	65	123	-	84	4	10	55	64	140	96	28.5	15
80 CD	-	31	35	90	179	-	93	6	13	90	83	178	124	44	46.5

Please order dimension sheet for type Spec.-I/CDB with safety pins.
For performance data see page 88.

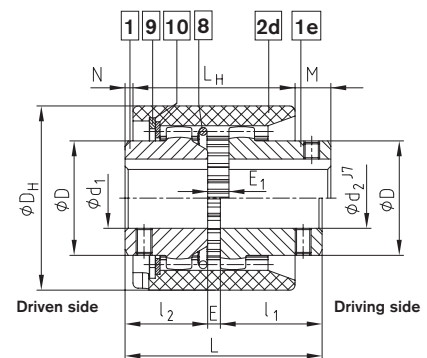

Ordering example:

BoWex® 45 SG	$d_1 \text{ } \varnothing 22$	$d_2 \text{ } \varnothing 40$
Size and type of coupling SG, SSR or Spec.-I/CD	Finish bore H7 keyway to DIN 6885 sheet 1 (JS9)	Finish bore H7 keyway to DIN 6885 sheet 1 (JS9)

BoWex® SD/SD-D Curved-tooth gear coupling®

Shiftable coupling (at standstill)

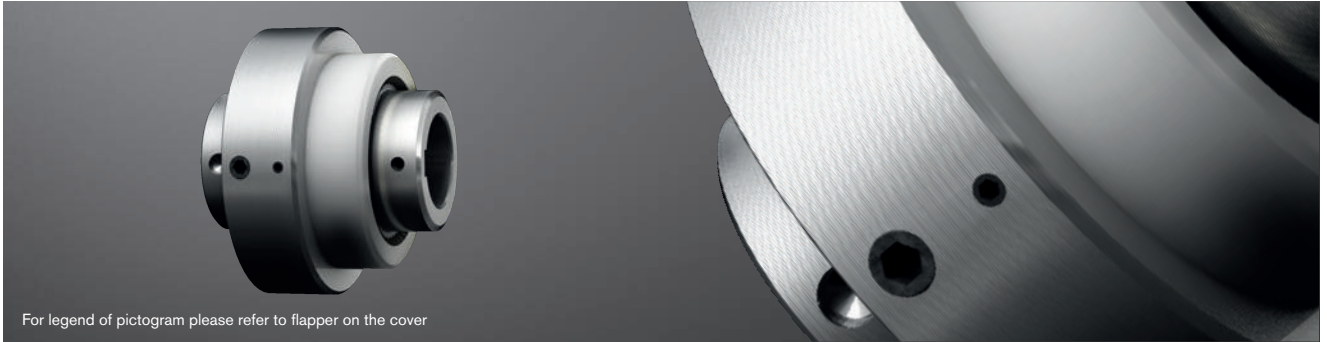

For legend of pictogram please refer to flapper on the cover

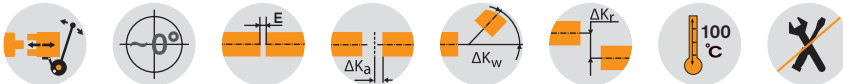

BoWex® Type SD																							
Size	Pilot bore		Finish bore d ₁ , d ₂			Dimensions [mm]												Weight with max. bore [kg]		Mass moment of inertia J with max. bore [kgcm ²]		Shifting force [N]	
	Unbo-red	Pilot bored	d ₁	d ₁ max.	d ₂ max.	E	l ₁	l ₂	L	L _H	l ₃	M	W	N	D	D _H	D _A	Shifting hub with sleeve	Driving hub	Shifting hub with sleeve	Driving hub		
24 SD	x	-	For finish bores see stock programme on page 88	24	24	4	26	50	80	52	31	10	19	18	36	58	78	1.08	0.14	8.23	0.36	140	
28 SD	x	-		28	28	4	40	55	99	57	33	21.5	21.5	20.5	44	70	88	1.50	0.33	15.62	1.22	180	
32 SD	x	-		32	32	4	40	55	99	58	33	20.5	21.5	20.5	50	84	100	1.85	0.43	22.87	2.17	180	
45 SD	x	-		45	45	4	42	60	106	63	37	21.5	22.5	21.5	65	100	125	2.56	0.68	2.30	46.07	5.66	250
				48			50		114			29.5							0.79				
65 SD	-	21		65	65	4	55	70	129	77	37	28	28	25	24	95	140	156	5.07	2.30	158.99	43.96	350
80 SD	-	31		90	90	6	90	90	186	96	47	56	35	34	124	175	195	10.60	5.20	523.7	150.8	350	
100 SD	-	38		100	100	8	110	110	228	113	55	72	43	43	152	210	235	18.87	9.37	1350	401.3	400	
125 SD	-	45		125	125	10	140	140	290	149	70	89	52	52	192	270	298	40.40	9.44	4919	1362.3	450	

Connection dimensions of BoWex® SD shifting ring (comp. 17) for mounting of: slip ring SD1 (s. catalogue on p. 89), shifting disk etc.					
Size	Dimensions [mm]				
	L ₁	L ₂	z x G	s	
24 SD	48	58	4 x M6	2	
28 SD	48	58	4 x M6	2	
32 SD	64	75	4 x M6	2	
45 SD	75	90	4 x M8	2	
65 SD	100	114	4 x M8	2	
80 SD	130	145	4 x M8	3	
100 SD	180	196	6 x M10	4	
125 SD	220	236	6 x M10	4	

Performance data/torques see type M (on page 88), max. circumferential speed v = 20 m/s, referring to ØD_A
Other sizes on request

Ordering example:	BoWex® 32 SD	d ₁ Ø32	d ₂ Ø32
	Size and type of coupling	Finish bore H7 keyway to DIN 6885 sheet 1 (JS9)	Finish bore H7 keyway to DIN 6885 sheet 1 (JS9)

Components

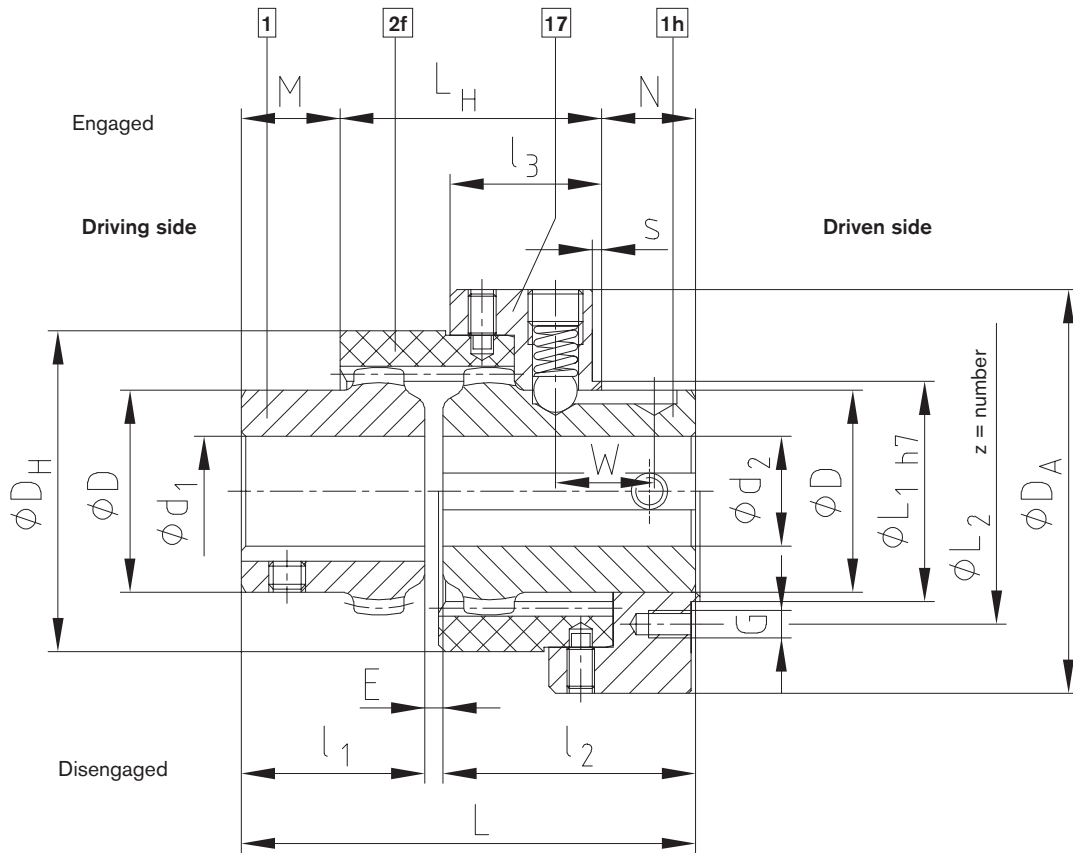

BoWex® SD

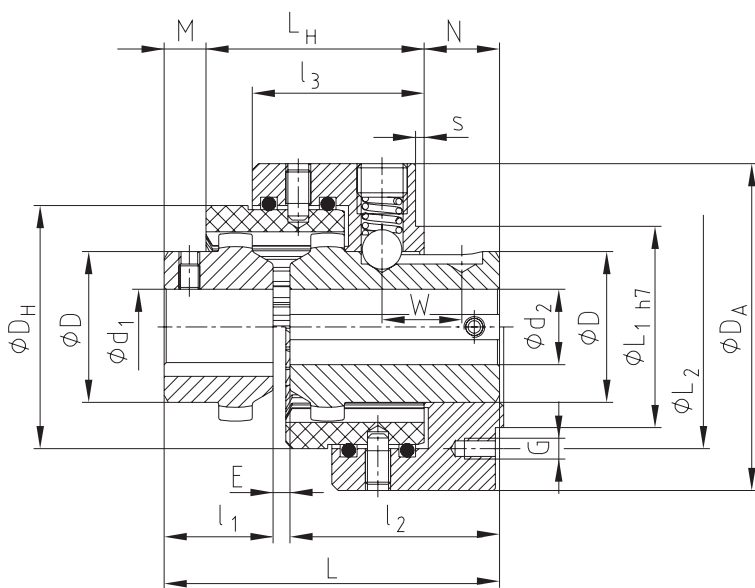

BoWex® SD-D

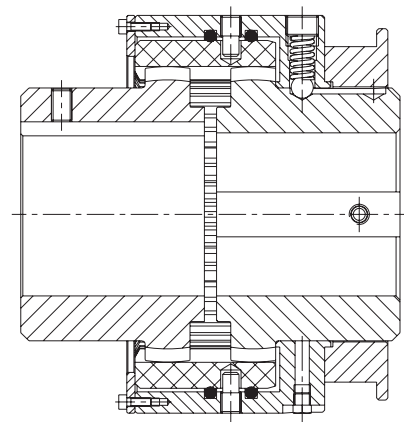

BoWex® SD-D3

GEARex®

BoWex® SD1 Curved-tooth gear coupling®

Shiftable coupling with shiftable linkage (at standstill)

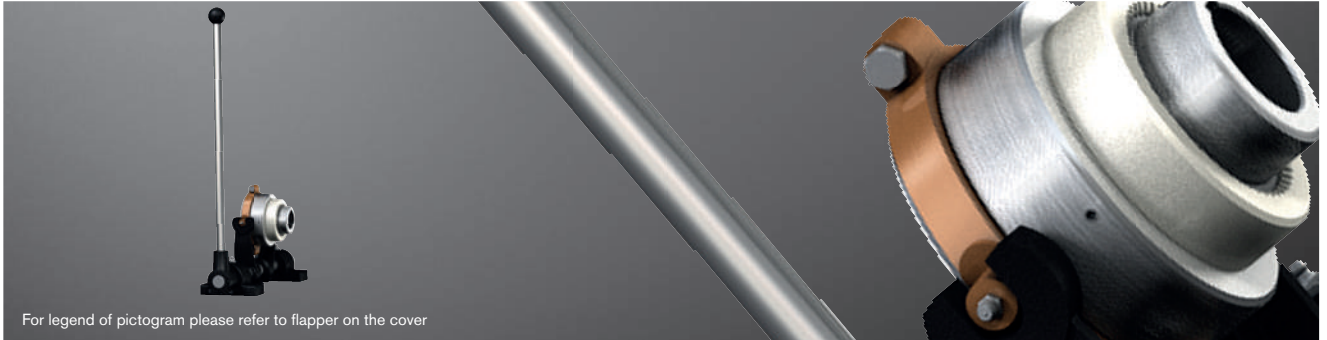

For legend of pictogram please refer to flapper on the cover

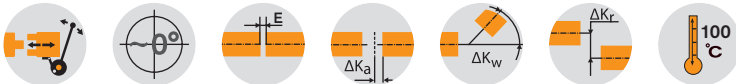

BoWex® Type SD1 and slip ring																					
Size	Finish bore			Dimensions [mm]																	Shifting force [N]
	d ₁	d ₁ max.	d ₂ max.	E	l ₁	l ₂	L	L _G	l ₄	l ₅	M	W	t	D	D _H	D _A	D ₁	D ₂ ±0.1 (keyway)	D ₅	n ±0.1 (keyway)	
24 SD1		24	24	4	26	50	80	67	11	46	10	19	16	36	58	78	45	70.5	78	12.5	140
28 SD1		28	28	4	40	55	99	72	11	48	21.5	21.5	16	44	70	88	45	70.5	78	12.5	180
32 SD1		32	32	4	40	55	99	78	13.5	53	20.5	21.5	21	50	84	100	60	89.5	100	17.5	180
45 SD1	For finish bores see stock programme on page 86	45		4	42		106				21.5										
		48	45		50	60	114	84	14	58	29.5	22.5	22	65	100	125	70	112.5	125	18	250
65 SD1		65	65	4	55	70	129	103	16	61	26	25	25	96	140	156	96	130.5	145	20.5	350
80 SD1		80	80	6	90	90	186	124	18.5	75	56	35	29	124	175	195	125	164.5	182	25.5	350
100 SD1		100	100	8	110	110	228	152	28	94	72	43	39	152	210	235	174	210.5	230	30.5	400
125 SD1		125	125	10	140	140	290	193	30.5	114	89	52	44	192	270	298	214	250.5	275	35.5	450

BoWex® Type SD1 - Shiftable linkage																					
Size	Shiftable linkage size	Slip ring size	Dimensions [mm]															Dimensions with m ₁ max.			
			a	b	c	d	d ₃	d ₄	e	F	g ₁	L ₂	L ₃	m	m ₁ min.	m ₁ max.	A	B	m ₃	m ₄	m ₅
24 SD1	1	1.1																			
28 SD1	1	1.1	110	50	18	20	11	16	30	70	55	320	400	75	180	190	90	114		55	16
32 SD1	2	2.2				25				97.5	60	430	450		240	270	111	151	20	80	34
45 SD1	3	3.3	140			30		20	40	120		490	600	100	280	310	140	180		90	44
65 SD1	3	4.4		60	25						70						170	210			
80 SD1	4	5.5				35	13.5			50	147.5				321	365	200	244		100	54
100 SD1	5	6.6	160			40		30	50 ¹⁾	190	80	630	1085	120	365	410	250	300	30	110	62
125 SD1	5	7.7													-		300	350			

¹⁾ = With a continuous base plate the dimension „e“ has to be increased by at least 10 mm. The brackets of the driving and driven side have to be adjusted accordingly. Also available as type SD-D. Other sizes on request.

Performance data/torques see type M (on page 88), max. circumferential speed v = 20 m/s, referring to ØD_A

Ordering example:	BoWex® 65 SD1	d ₁ Ø32	d ₂ Ø32	4.4	3
	Size and type of coupling	Finish bore H7 keyway to DIN 6885 sheet 1 (JS9)		Slip ring Size	Shiftable linkage Size

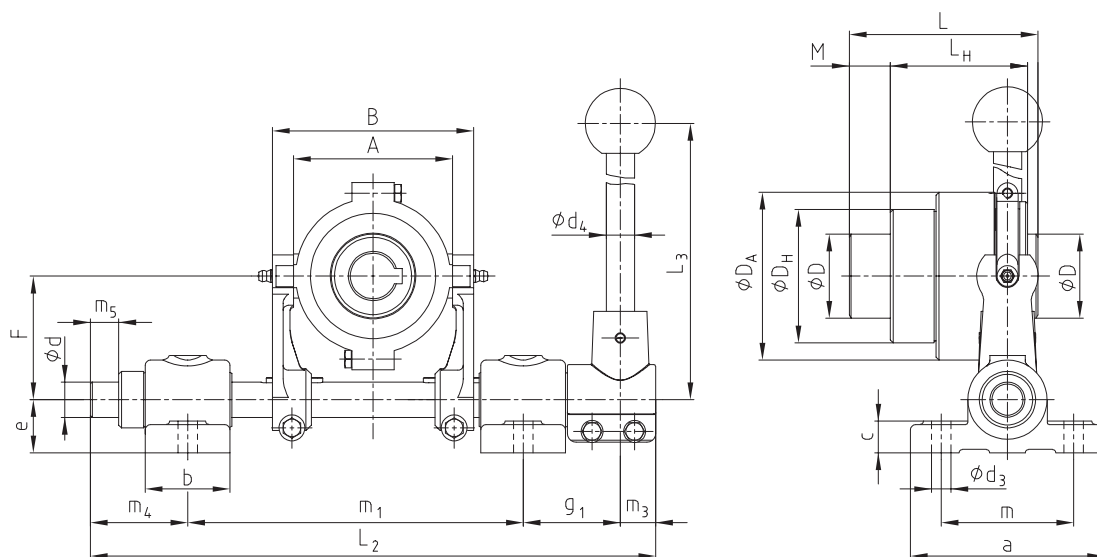
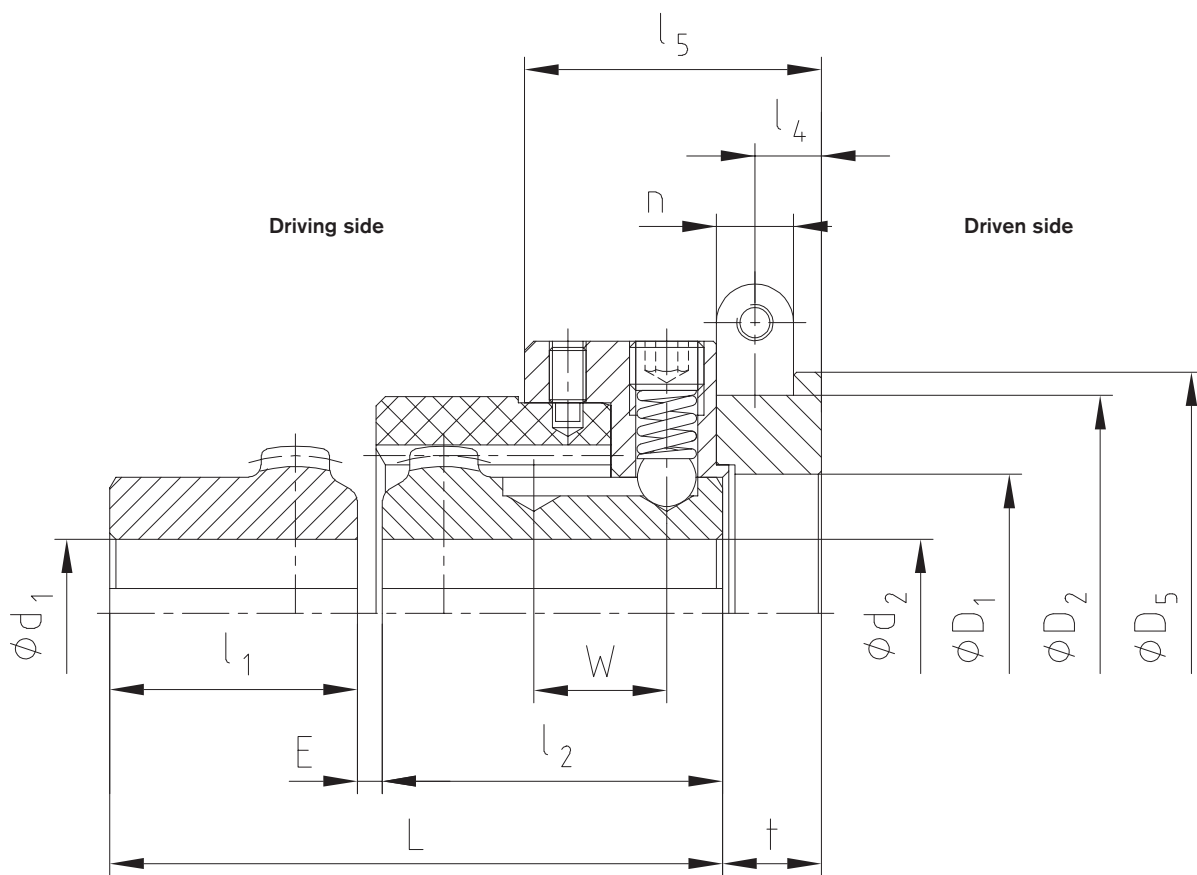

BoWex® GT Curved-tooth gear coupling®

Split CFK sleeve for high power density



For legend of pictogram please refer to flapper on the cover

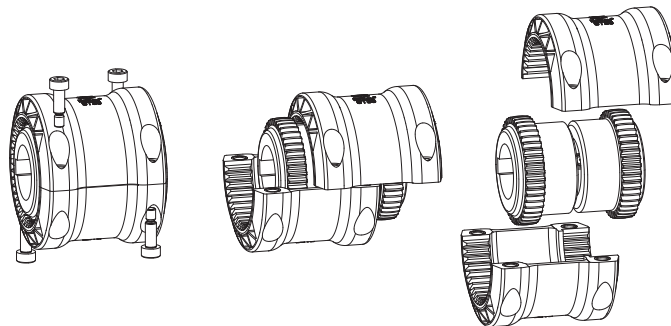
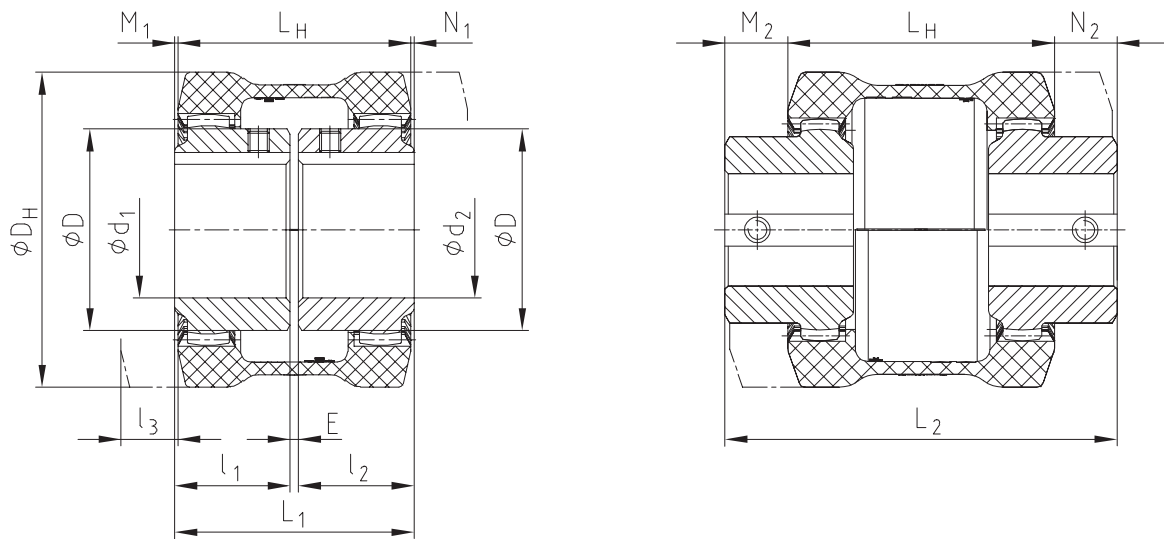
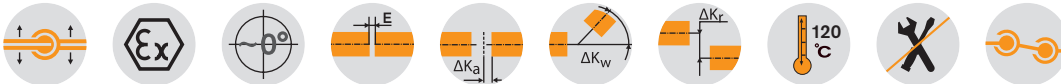

BoWex® Type GT with split sleeve

Size	Torque [Nm]			Finish bore d _{max.}		Dimensions [mm]										Weight with max. bore [kg]			Mass moment of inertia J with max. bore [kgcm ²]			
	T _{KN}	T _{K max}	T _{KW}	d ₁	d ₂	D	D _H	L _H	l ₁	l ₂	l ₃	E	L ₁	L ₂	M ₁ , N ₁	M ₂ , N ₂	Sleeve	Hub	Total	Sleeve	Hub	Total
28	70	210	35	28	28	44	80	80	40	40	15	4	84	124	2	22	0.158	0.22	0.702	1.77	1.22	4.21
38	120	360	60	38	38	58	98	83	40	40	18	4	84	122	0.5	19.5	0.25	0.45	1.15	4.43	3.36	11.15
48	200	600	100	48	48	68	110	106	50	50	21	4	104	160	0	28	0.33	0.67	1.68	7.39	6.11	19.61
65	560	1680	280	65	65	96	150	111	55	55	27	4	114	160	1.5	24.5	0.69	1.54	3.77	28.9	31.80	92.5

l₃ = Drop-out center dimension required

Ordering example:	BoWex® GT-28	d ₁ Ø20	d ₂ Ø28
	Size and type of coupling	Finish bore H7 keyway to DIN 6885 sheet 1 (JS9)	Finish bore H7 keyway to DIN 6885 sheet 1 (JS9)

BoWex® ZR Curved-tooth gear coupling®

Bridging larger shaft distances

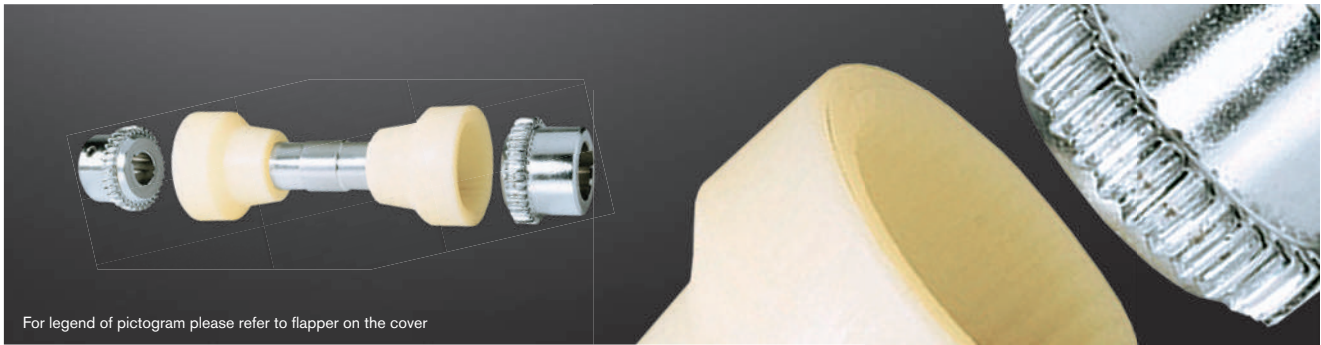

For legend of pictogram please refer to flapper on the cover

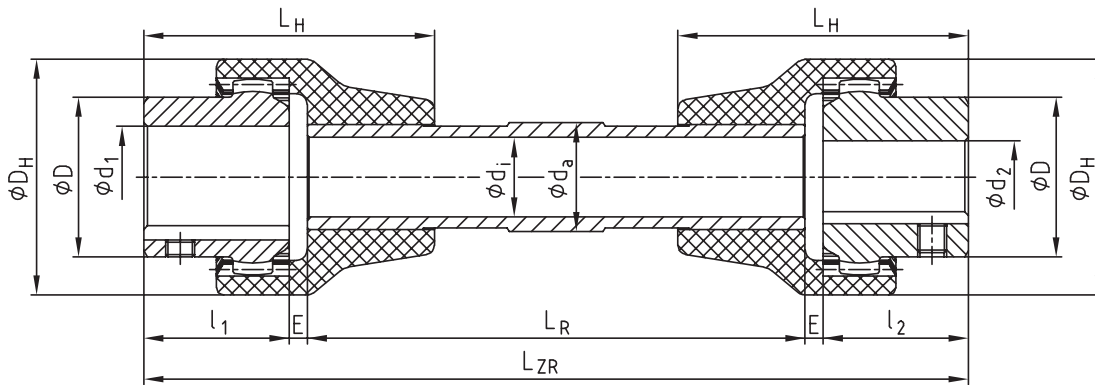
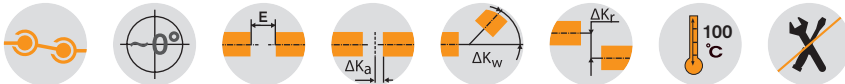

BoWex® Type ZR															
Size	Pilot bore	Finish bore	Dimensions [mm]										Torque [Nm]		
		d1 max. d2 max.	l1, l2	Hub length. max. l1, l2	LH	E	LZR tot.	LR	D	DH	di	da	TKN	TK max	TKW
14	-	14	23	40	40	3	According to customer specification		25	40	21	25	10	20	5
28	-	28	40	55	60	3			44	66	30	26	45	90	23
42	-	42	42	60	85	3			65	95	40	50	100	200	50
48	-	48	50	60	85	3			68	95	40	50	140	280	70

BoWex® ZR couplings are available up to a length of 2000 mm for serial applications only ($n_{max.} = 1000$ rpm)

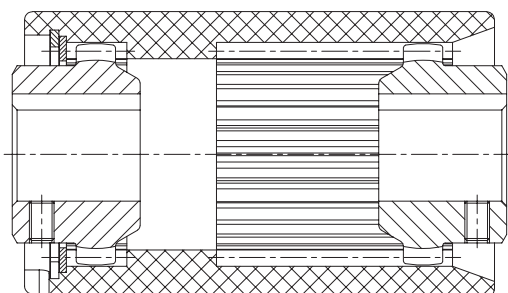

Type Spec.-I with a long PA-sleeve

- BoWex® Spec.-I with lengthened sleeve on request
- Bridging larger shaft distances
- Axial shifting of driving and driven shaft at standstill
- Maintenance-free
- Compensating for larger displacements
- Axial plug-in
- Application range from -25 °C to +100 °C

BoWex® HEW Compact Curved-tooth gear coupling®

Compensating for large displacements, very compact design

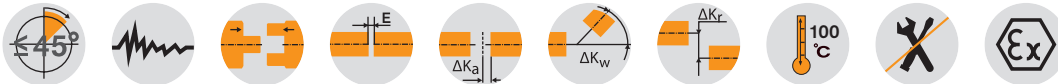
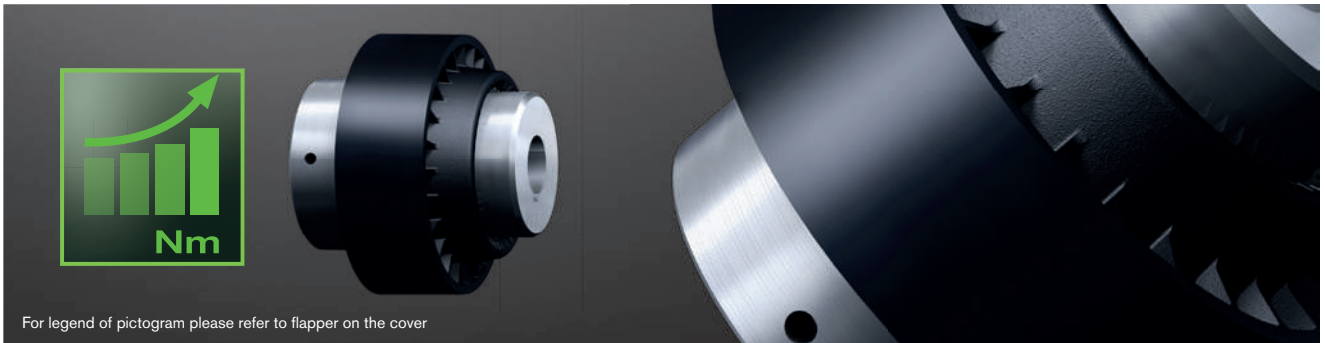

BoWex® Type HEW Compact																Weight with pilot bored coupling [kg]	Mass moment of inertia with pilot bored coupling J ₁ [kgm ²]	Mass moment of inertia with pilot bored coupling J ₂ [kgm ²]
Size	Max. finish bore d		Dimensions [mm]															
	d ₁	d ₂	D ₁	D ₂	D ₄	l ₁	l ₂	l ₃	l ₄	E	L	L ₁	D ₃	z	M			
42-130	42	42	90	65	131	42	42	45	37	34	118	98	78	6	M6	3.4	0.003	0.001
65-180	65	65	130	96	180	60	55	55	47	30	145	122	110	8	M10	9	0.014	0.006
80-225	75	90	145	124	225	70	90	77	51	50	210	158	120	10	M12	18.9	0.035	0.029
100-305	100	100	200	152	305	90	110	90	73	58	258	187	175	16	M12	40.2	0.152	0.087
125-365	125	125	235	192	365	120	140	150	90	68	328	240	205	12	M16	75	0.36	0.26

Technical data												
Coupling size	Elastomer hardness [Shore A]	Torque [Nm]			Perm. speed n _{max} [rpm]	Perm. damping power			Dynamic torsion spring stiffness C _t dyn [Nm/rad]	Relative damping ψ	Resonance factor V _R ≈ 2·Π/ψ	Radial torsion spring stiffness C _r [Nm/rad]
		T _K	T _K max	with 10 Hz T _{KW}		PKW						
						60 °C	80 °C	90 °C				
BoWex® 42 HEW Compact	T50	200	400	50	7300	30	18	12	780	0.8	7.9	178
	T65	270	540	68					2400	1.2	5.2	600
	T70	320	640	80					2900	1.2	5.2	710
BoWex® 65 HEW Compact	T50	550	1100	138	5500	55	33	22	2850	0.8	7.9	379
	T65	740	1500	185					7800	1.2	5.2	955
	T70	860	1700	215					9500	1.2	5.2	1240
BoWex® 80 HEW Compact	T50	1250	2500	313	4400	90	54	36	5000	0.8	7.9	420
	T65	1600	3200	400					13000	1.2	5.2	1090
	T70	1900	3800	475					16500	1.2	5.2	1450
BoWex® 100 HEW Compact	T50	2750	5500	688	3200	150	90	60	17000	0.8	7.9	760
	T65	3900	7800	975					44000	1.2	5.2	1850
	T70	4500	9000	1125					50000	1.2	5.2	2250
BoWex® 125 HEW Compact	T50	5500	11000	1375	2900	220	132	88	25000	0.8	7.9	750
	T65	7500	15000	1875					62000	1.2	5.2	1930
	T70	8400	16800	2100					70000	1.2	5.2	2300

■ = Years of experience with applications at customer sites and additional test series in the KTR test field in Rheine enabled us to determine potentials allowing for an increase of the rated torques with some sizes of this series.

Ordering example:	BoWex® 65 HEW Compact	T50	d ₁ Ø40	d ₂ Ø65
	Size and type of coupling	Elastomer hardness	Finish bore H7 keyway to DIN 6885 sheet 1 (JS9)	Finish bore H7 keyway to DIN 6885 sheet 1 (JS9)

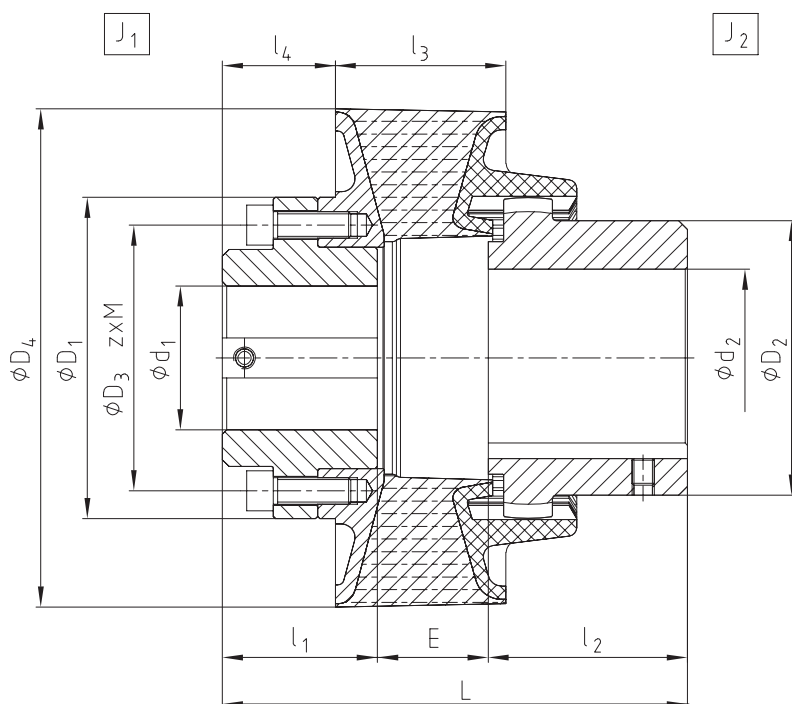

BoWex® HEW Compact with reduced hub

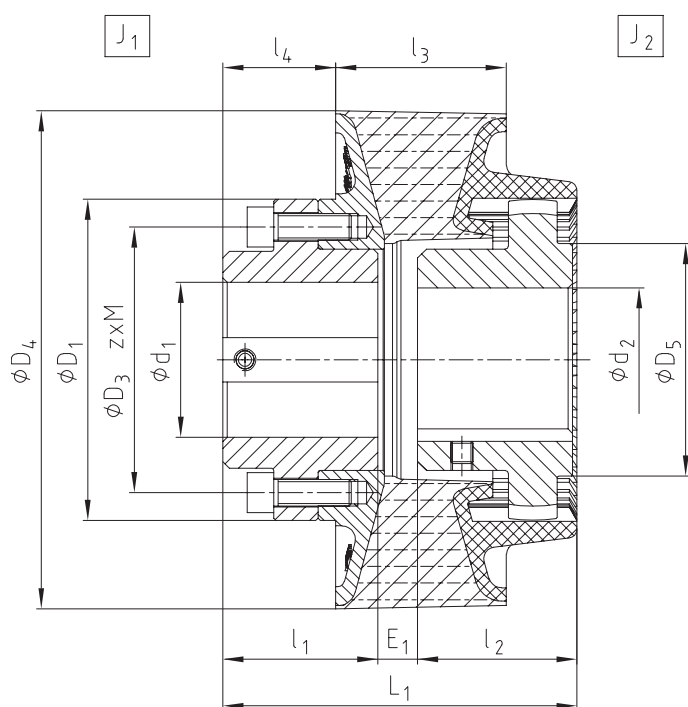

BoWex® M Curved-tooth gear coupling®

Made of corrosion-resistant materials

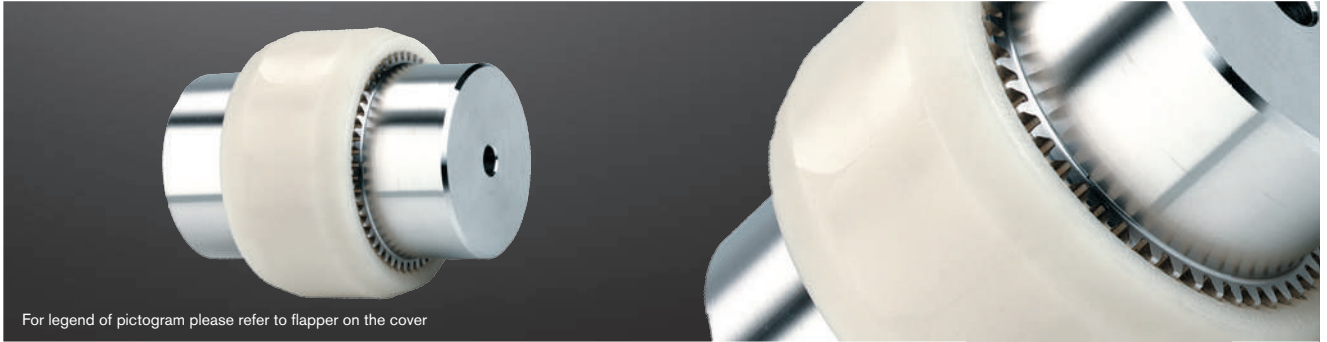

For legend of pictogram please refer to flapper on the cover



BoWex® junior plug-in coupling (two-part) and BoWex® junior M (three-part)

Size	Finish bore				Dimensions [mm]									
	Hub Component 1b		Plug-in sleeve Component 2b		D _H	l ₁ , l ₂	E ₁	E	L _{H1}	L _H	L ₁	L	M ₁	M, N
	d ₁	D ₁	d ₂	D ₂										
14	Ø6, Ø7, Ø8, Ø9	22	Ø8	22	40	23	2	4	40	37	48	50	8	6.5
M-14	Ø10, Ø11	25	Ø10, Ø11	25										
	Ø12, Ø14	26	Ø12, Ø14	26										
19	Ø12, Ø14	27	Ø14, Ø15	29	48	25	2	4	42	37	52	54	10	8.5
M-19	Ø16	30												
	Ø19	32												
24	Ø10, Ø11, Ø12	26	Ø14, Ø16	32	53	26	2	4	45	41	54	56	9	7.5
M-24	Ø14, Ø15, Ø16	32												
	Ø18, Ø19, Ø20	36												
	Ø24	38	Ø24	40										

BoWex® Type M

Size	Finish bore d ₁ max. d ₂ max.	Dimensions [mm]						
		D _H	D	l ₁ , l ₂	E	L _H	L	M, N
M-24	24	53	36	26	4	41	56	7.5
M-38	38	83	58	40	4	48	84	18
M-48	48	95	68	50	4	50	104	27

Other coupling sizes: M-24C, M-38C, M-48C on request. Setscrews with BoWex® junior coupling are made of V4A as a standard. For performance data see page 88.

Applications:

Food industry, print and paper industry, textile industry, sewage technology, wash-mobiles, chemical and pharmaceutical industry, offshore units, etc. For use in aggressive environment (air, water, chemicals, etc.).

Ordering
example:

BoWex® M-24 V4A	d ₁ Ø20	d ₂ Ø24
Size and type of coupling	Finish bore H7 keyway to DIN 6885 sheet 1 (JS9)	Finish bore H7 keyway to DIN 6885 sheet 1 (JS9)

Type junior plug-in coupling (two-part)

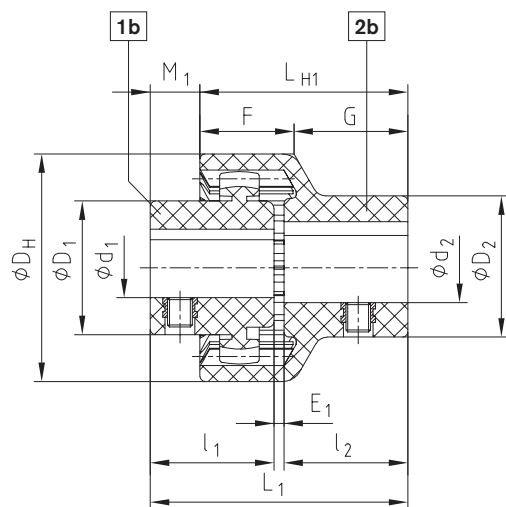

Type junior M coupling (three-part)

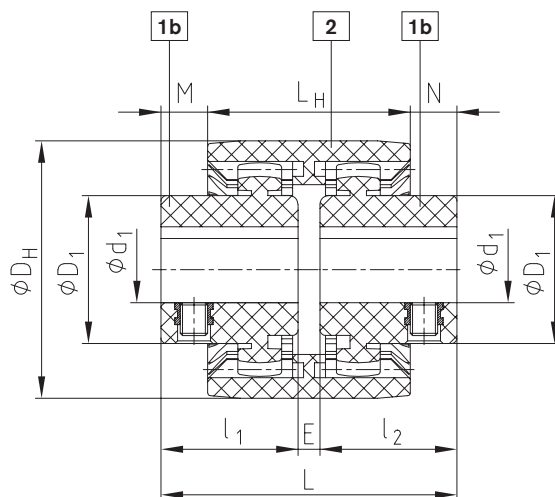

Type M (V4A)

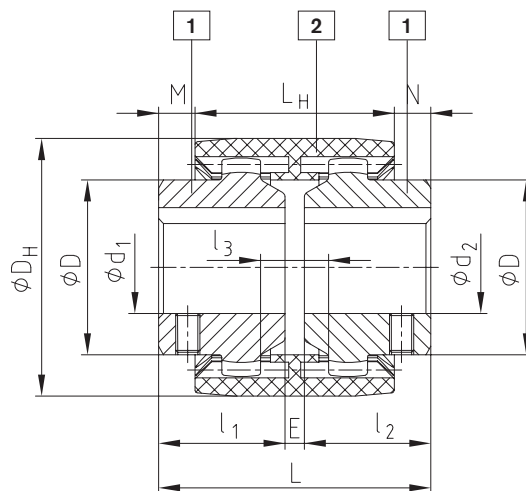

BoWex® Curved-tooth gear coupling®

Taper bores

BoWex® with taper bore

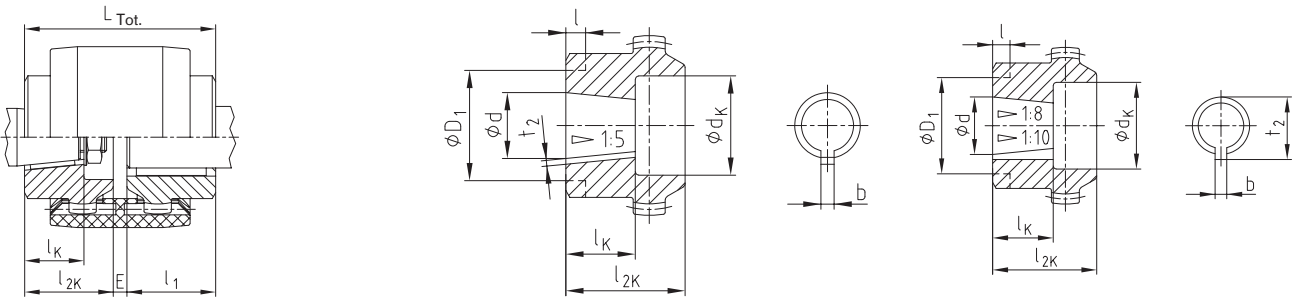

$$L_{Tot} = l_1 + E + l_{2K}$$

see stock programme on page 90

Taper bores 1:5																							
Dimensions [mm]					Counterbore d_K and hub length l_{2K} [mm] Recess on hub collar $D_1 \times l$ [mm]																		
Code	Details of bores				14		19		24		28		32		38		42		48		65		
	$d^{+0.05}$	b^{J59}	$t_2^{+0.1}$	l_K	d_K	l_{2K}	d_K	l_{2K}	d_K	l_{2K}	d_K	l_{2K}	d_K	l_{2K}	d_K	l_{2K}	d_K	l_{2K}	d_K	l_{2K}	d_K	l_{2K}	
A-10	9.85	2	1.0	11.5	18	23	18	25	25	26	25	26	25	26	25	26							
B-17	16.85	3	1.8	18.5			30 x 7	30	30	36	40	36	40	36	40	36	40	45	42	45	42	45	50
C-20	19.85	4	2.2	21.5					28	36	36	40	36	40	36	40	45	42	45	42	45	50	
Cs-22	21.95	3	1.8	21.5					28	36	36	40	36	40	36	40	45	42	45	42			
D-25	24.85	5	2.9	26.5							36	40	36	40	36	40	45	42	45	42	45	50	
E-30	29.85	6	2.6	31.5											45	55	45	55	45	55	45	55	
F-35	34.85	6	2.6	36.5																52	60	55	60
G-40	39.85	6	2.6	41.5																52	60	65	70

Taper bores 1:8																						
Dimensions [mm]					Counterbore d_K and hub length l_{2K} [mm] Recess on hub collar $D_1 \times l$ [mm]																	
Code	Details of bores				14		19		24		28		32		38		42		48		65	
	$d^{+0.05}$	b^{J59}	$t_2^{+0.1}$	l_K	d_K	l_{2K}	d_K	l_{2K}	d_K	l_{2K}	d_K	l_{2K}	d_K	l_{2K}	d_K	l_{2K}	d_K	l_{2K}	d_K	l_{2K}	d_K	l_{2K}
N/1	9.7 ± 0.015	2.4 ^{+0.05}	10.85	17	18	26	18	25	25	26	25	30	25	30	25	30						
N/1c	11.6	3 ^{J59}	12.90	16.5	18	23			25	26	25	30										
N/1e	13	2.4 ^{+0.05}	13.80	21					25	30	25	30			25	30						
N/1d	14	3 ^{J59}	15.50	17.5	20	23	25	30	28	30	28	30	28	40								
N/2	17.287	3.2 ^{+0.05}	18.24	24					28	35	36	40	36	40	36	40	45	42	45	42	45	50
N/2a	17.287	4 ^{J59}	18.94	24					28	35	36	40	36	40	36	40	45	42	45	42	45	50
N/2b	17.287	3 ^{J59}	18.34	24					28	35					36	40	45	42	45	42		
N/3	22.002	4 ^{J59}	23.40	28							36	40	36	40	36	40	45	42	45	42	45	50
N/4	25.463	4.78 ^{+0.05}	27.83	36							36	50	36	50	36	50	45	50	45	50	45	62
N/4b	25.463	5 ^{J59}	28.23	36													58 x 10	58 x 10				
N/4a	27	4.78 ^{+0.05}	28.80	32.5							36	50			36	50						
N/4g	28.45	6 ^{J59}	29.32	38.5											36	60	45	60	45	60		
N/5	33.176	6.38 ^{+0.05}	35.39	44											45	60	45	60	45	60	45	62
N/5a	33.176	7 ^{J59}	35.39	44													45	60	45	60	45	62

Taper bores 1:10																						
Dimensions [mm]					Counterbore d_K and hub length l_{2K} [mm]																	
Code	Details of bores				14		19		24		28		32		38		42		48		65	
	$d^{+0.05}$	b^{J59}	$t_2^{+0.1}$	l_K	d_K	l_{2K}	d_K	l_{2K}	d_K	l_{2K}	d_K	l_{2K}	d_K	l_{2K}	d_K	l_{2K}	d_K	l_{2K}	d_K	l_{2K}	d_K	l_{2K}
CX-20	19.85	5	22.08	32							36	50			36	50	45	50	45	50		
DX-25	24.95	6	26.68	45											36	50	45	60	45	60	45	60
EX-30	29.75	8	31.88	50													45	60	45	60	45	70

Spline hubs and inch bores

BoWex® spline hubs – basic programme

Spline hub (N)

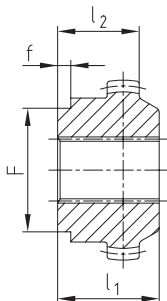

Clamping hub (K)

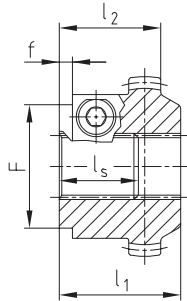

If it is not possible to fasten the hubs of pump shafts with involute spline by means of an end plate and a screw, we recommend to use our spline clamping hub.

Radial clamping ensures a backlash-free tight fit on the pump shaft.

Spline and clamping hubs to DIN 5480

Size	Dimensions [mm]							Order designation specify coupling size
	Type	Spline size	l ₁	l ₂	l _S	F	f	
42	N	25x1.25x18	42	-	-	-	-	P000205
	K	25x1.25x18	42	-	-	-	-	P500202
48	K	30x2x14	42	-	-	60	6	P500203
	N	30x2x14	50	-	-	60	6	P000206
	K	30x2x14	50	-	-	60	6	P500203
65	N	35x2x16	55	-	-	60	6	P000303
	K	35x2x16	60	-	-	60	6	P500301
	N	40x2x18	55	-	-	78	6	P000304
65	K	40x2x18	60	-	-	78	6	P500302
	K	45x2x21	55	-	-	78	6	P500401

Spline and clamping hubs to ANSI B92.1

Size	Dimensions [mm]							Order designation specify coupling size
	Type	Spline size	l ₁	l ₂	l _S	F	f	
42	K	PH-S 5/8"	42	-	-	-	-	P558101
	K	16/32DP, z=9	-	35	-	-	-	P559101
42	K	PI-S 3/4"	-	35	-	-	-	P559101
	K	16/32DP, z=11	-	35	-	-	-	P559101
48	K	PB-S 7/8"	42	-	-	60	3	P567101
	K	16/32DP, z=13	-	-	-	60	3	P567101
48	K	PB-BS 1"	42	-	27	50	6	P660201
	K	16/32DP, z=15	-	-	27	50	6	P660201
48	K	PA-S 3/8"	50	-	45	52	7	P663301
	K	16/32DP, z=21	-	-	45	52	7	P663301
65	K	PA-S 3/8"	55	-	48	52	5	P663301
	K	16/32DP, z=21	-	-	48	52	5	P663301
65	K	PC-S 1 1/4"	55	-	44	52	5	P656201
	K	12/24DP, z=14	-	-	44	52	5	P656201

Inch bores – see stock programme page 86

Bore and keyway acc. to ANSI/AGMA 9002-C14 Bore (clearance fit) Keyway (commercial class fit)					Bore and keyway acc. to ANSI/AGMA 9002-C14 Bore (clearance fit) Keyway (commercial class fit)						
KTR Code	Bore Ø [Inch]	Width of keyway [Inch]	Bore Ø [mm]	Width of keyway [mm]	Keyway depth/Tolerance +0.381 [mm]	KTR Code	Bore Ø [Inch]	Width of keyway [Inch]	Bore Ø [mm]	Width of keyway [mm]	Keyway depth/Tolerance +0.381 [mm]
Tb	3/8	1/8	9.525 ^{+0.0254}	3.175 ^{+0.05}	10.972	Sd	1 1/8	5/16	28.575 ^{+0.0254}	7.937 ^{+0.051}	32.105
DNB	7/16	3/32	11.112 ^{+0.0254}	2.382 ^{+0.051}	12.293	Js	1 1/4	1/4	31.75 ^{+0.0254}	6.35 ^{+0.051}	34.721
T	1/2	3/16	12.7 ^{+0.0254}	4.762 ^{+0.051}	14.757	K	1 1/4	5/16	31.75 ^{+0.0254}	7.937 ^{+0.051}	35.331
Ta	1/2	1/8	12.7 ^{+0.0254}	3.175 ^{+0.051}	14.224	Ma	1 3/8	5/16	34.925 ^{+0.0254}	7.937 ^{+0.051}	38.557
DNC	17/32	1/8	13.495 ^{+0.0254}	3.175 ^{+0.051}	15.011	RH1	1 3/8	3/8	34.925 ^{+0.0254}	9.525 ^{+0.063}	39.141
Do	9/16	1/8	14.287 ^{+0.0254}	3.175 ^{+0.051}	15.824	Cb	1 7/16	3/8	36.512 ^{+0.0254}	9.525 ^{+0.063}	40.767
E	5/8	1/8	15.875 ^{+0.0254}	3.175 ^{+0.051}	17.424	Ca	1 1/2	5/16	38.1 ^{+0.0254}	7.937 ^{+0.051}	41.783
Es	5/8	5/32	15.875 ^{+0.0254}	3.968 ^{+0.051}	17.729	C	1 1/2	3/8	38.1 ^{+0.0254}	9.525 ^{+0.0635}	42.392
Ed	5/8	3/16	15.875 ^{+0.0254}	4.762 ^{+0.051}	18.008	Nb	1 5/8	3/8	41.275 ^{+0.0254}	9.525 ^{+0.0635}	45.618
DNH	11/16	3/16	17.462 ^{+0.0254}	4.762 ^{+0.051}	19.634	Ls	1 3/4	3/8	44.45 ^{+0.0254}	9.525 ^{+0.0635}	48.818
Ad	3/4	1/8	19.05 ^{+0.0254}	3.175 ^{+0.051}	20.624	L	1 3/4	7/16	44.45 ^{+0.0254}	11.112 ^{+0.0635}	49.428
A	3/4	3/16	19.05 ^{+0.0254}	4.762 ^{+0.051}	21.259	Lu	1 7/8	1/2	47.625 ^{+0.0254}	12.7 ^{+0.0635}	53.238
G	7/8	3/16	22.225 ^{+0.0254}	4.762 ^{+0.051}	24.485	Da	1 15/16	1/2	49.212 ^{+0.0254}	12.7 ^{+0.0635}	54.864
F	7/8	1/4	22.225 ^{+0.0254}	6.35 ^{+0.051}	25.069	Ds	2	1/2	50.8 ^{+0.0254}	12.7 ^{+0.0635}	56.464
Gf	15/16	1/4	23.812 ^{+0.0254}	6.35 ^{+0.051}	26.695	Pa	2 1/8	1/2	53.975 ^{+0.0381}	12.7 ^{+0.063}	59.69
H	1	3/16	25.4 ^{+0.0254}	4.762 ^{+0.051}	27.686	U	2 1/4	1/2	57.15 ^{+0.0381}	12.7 ^{+0.063}	62.915
Hs	1	1/4	25.4 ^{+0.0254}	6.35 ^{+0.051}	28.295	Ub	2 3/8	5/8	60.325 ^{+0.0381}	15.875 ^{+0.076}	67.335
R	1 1/16	3/16	26.987 ^{+0.0254}	4.762 ^{+0.051}	29.286	Wd	3 3/8	7/8	85.725 ^{+0.0381}	22.225 ^{+0.076}	95.504
Sb	1 1/8	1/4	28.575 ^{+0.0254}	6.35 ^{+0.051}	31.521	Wf	3 5/8	7/8	92.075 ^{+0.0381}	22.225 ^{+0.076}	101.955

The splines and inch bores specified are only a part of KTR's options. Many other variants are available, too.

GEARex® FA, FB and FAB

All-steel gear couplings

Coupling in accordance with AGMA 9008-B00, high power density



For legend of pictogram please refer to flapper on the cover

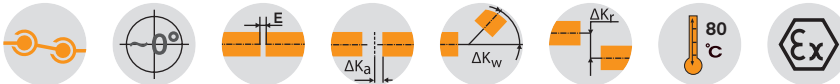

Dimensions																			
Size	Pilot bore	Max. finish bore		Dimensions [mm]															Grease capacity [dm ³] ²⁾
		d ₁ , d ₂	l ₁ , l ₂	Hub lengthened max. l ₁ , l ₂	EFA	EFB	EFAB	LFA	LFB	LFAB	L ₃	D	DA ₁	DA ₂	F ¹⁾	d ₃ ¹⁾			
10	26	50	43	105	3	21	12	89	107	98	55	67	111	83	74	52	0.02		
15	26	64	50	115	3	15	9	103	115	109	59	87	152	106	84	68	0.04		
20	31	80	62	130	3	31	17	127	155	141	79	108	178	129	104	85	0.08		
25	38	98	76	150	5	29	17	157	181	169	93	130	213	157	123	110	0.12		
30	44.5	112	90	170	5	33	19	185	213	199	109	153	240	181	148	130	0.18		
35	46	133	105	185	6	40	23	216	250	233	128	180	280	213	172	150	0.22		
40	52	158	120	215	6	42	24	246	282	264	144	214	318	249	192	175	0.35		
45	80	172	135	245	8	50	29	278	320	299	164	233	347	273	216	190	0.45		
50	80	192	150	295	8	56	32	308	356	332	182	260	390	308	241	220	0.70		
55	90	210	175	300	8	70	39	358	420	389	214	283	425.5	333	275	250	0.90		
60	100	232	190	305	8	84	46	388	464	426	236	312	457	364.5	316	265	1.15		
70	100	276	220	310	10	76	43	450	516	483	263	371	527	424	360	300	1.50		

Technical data										
Size	Torque [Nm]		Max. speed [rpm]	Weight with max. bore [kg]			Mass moment of inertia with max. bore [kgm ²]	Dowel screw (10.9)		
	T _{KN}	T _{KN} (42CrMo4)		Sleeve	Hub	Total		z	M	T _A [Nm]
10	930	1580	8500	0.75	0.55	2.73	0.00436	6	M6	15
15	2000	3300	6400	1.88	1.12	6.38	0.01894	8	M8	36
20	3500	6300	5400	2.60	2.09	9.94	0.04000	6	M10	72
25	6500	11000	4500	4.43	3.56	16.83	0.09749	6	M12	125
30	10000	17400	4000	5.83	6.18	25.21	0.18080	8	M12	125
35	17000	28800	3500	9.71	9.87	41.25	0.41419	8	M14	200
40	28500	48500	3100	11.88	16.07	58.14	0.75535	8	M14	200
45	37000	62000	3000	15.72	21.42	77.08	1.17590	10	M14	200
50	51000	86000	2500	25.66	29.59	114.40	2.24991	8	M18	430
55	65000	110000	2300	31.52	40.30	150.41	3.45102	14	M18	430
60	85000	145000	2100	32.82	52.96	177.44	4.16734	14	M18	430
70	135000	240000	1850	43.52	85.77	268.20	9.32429	16	M20	610

■ = Standard

¹⁾ Space required to align the coupling and replace the gasket

²⁾ Grease capacity for each coupling half

Ordering example:	GEARex® FA 10	d ₁ Ø50	d ₂ Ø50
	Type and size of coupling	Finish bore with keyway to DIN 6885 sheet 1	Finish bore with keyway to DIN 6885 sheet 1

Type FA

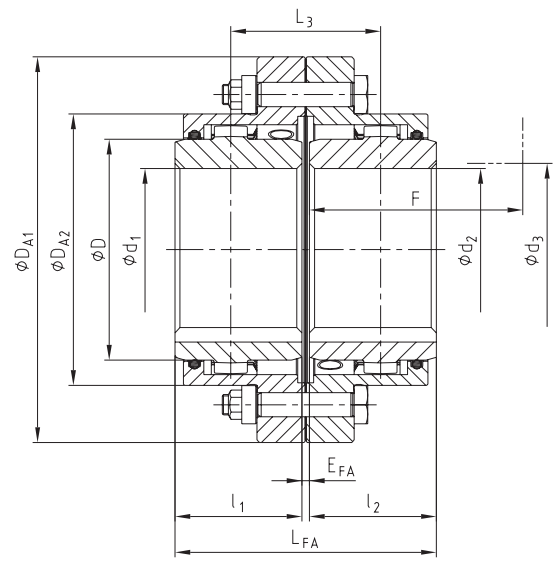

Type FB

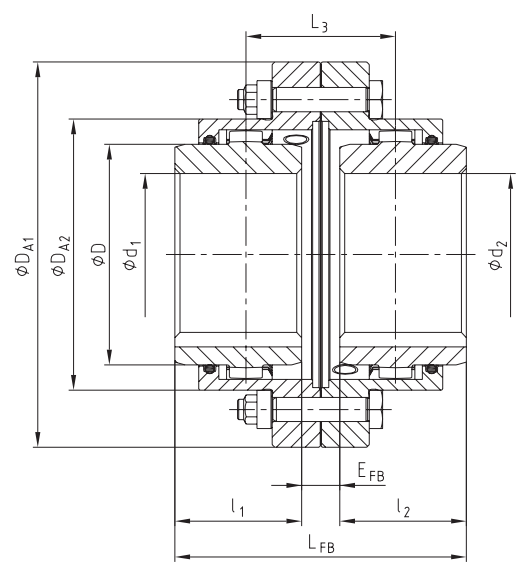

Type FAB

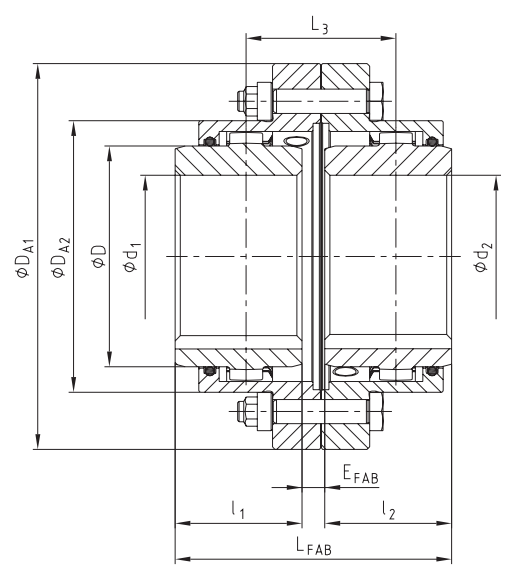

GEARex® DA, DB and DAB All-steel gear couplings

Easy to assemble, high power density

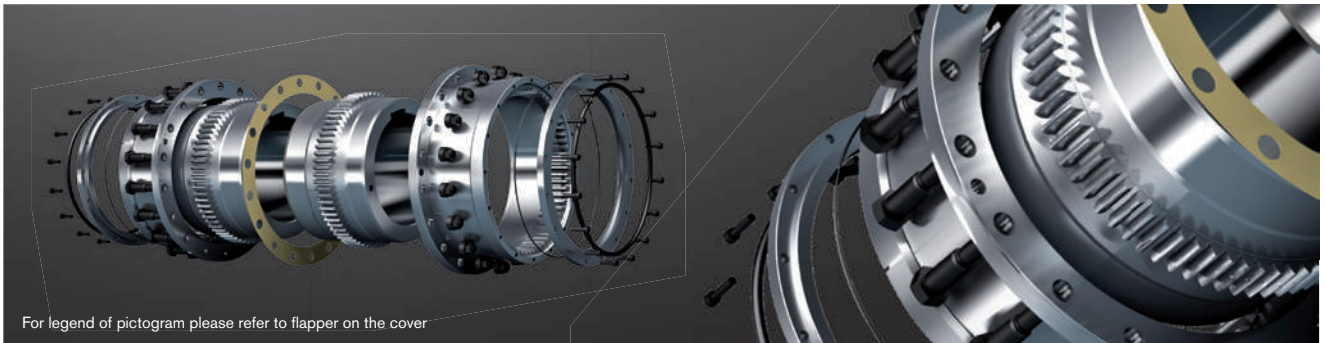

For legend of pictogram please refer to flapper on the cover

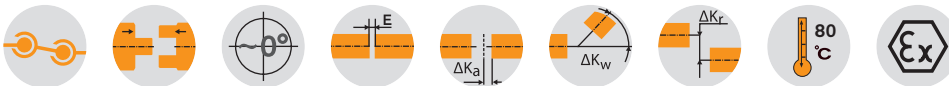

Dimensions																
Size	Pilot bore	Max. finish bore d ₁ , d ₂	Dimensions [mm]													Grease capacity [dm ³] ²⁾
			l ₁ , l ₂	FDA	EDB	EDAB	LDA	LDB	LDAB	L ₃	D	DA1	DA2	F ¹⁾	d ₃ ¹⁾	
20	31	80	62	3	31	17	133	155	144	79	108	187	146	105	85	0.08
25	38	98	76	5	29	17	157	181	169	93	130	220	172	115	105	0.12
30	44.5	112	90	5	33	19	185	213	199	109	153	248	194	140	120	0.18
35	46	133	105	6	40	23	216	250	233	128	180	285	228	165	145	0.22
40	52	158	120	6	42	24	246	282	264	144	214	335	270	180	160	0.35
45	80	172	135	8	50	29	278	320	299	164	233	358	294	195	185	0.45
50	80	192	150	8	56	32	388	356	332	182	260	390	332	215	205	0.70
55	90	210	175	8	70	39	358	420	389	214	283	425.5	354	240	220	0.90
60	100	232	190	8	84	46	388	464	426	236	312	457	380	260	245	1.15
70	100	276	220	10	76	43	450	516	483	263	371	527	445	300	290	1.50
80	140	300	280	10	50	30	570	610	590	310	394	545	475	340	310	2.50
85	160	325	292	13	53	33	597	637	617	325	430	585	515	352	330	3.00
90	180	350	305	13	83	48	623	693	658	353	464	640	560	365	360	4.00
100	220	390	330	13	93	53	673	753	713	383	512	690	612	390	400	5.00
110	220	420	350	20	296	158	720	996	858	508	560	765	665	410	420	6.00
120	260	450	420	25	421	223	864	1261	1063	643	608	825	720	480	470	7.50
130	300	500	440	25	415	220	905	1295	1100	660	684	950	805	520	520	9
140	380	550	460	20	430	225	940	1350	1145	685	750	1010	875	570	590	12
150	460	630	520	30	460	245	1070	1500	1285	765	850	1140	975	630	670	15

Technical data										
Size	Torque [Nm]		Max. speed [rpm]	Weight with max. bore [kg]			Mass moment of inertia with max. bore [kgm ²]	Dowel screw (10.9)		
	T _{KN}	T _{KN} (42CrMo4)		Sleeve	Hub	Total		z	M	T _A [Nm]
20	3500	6300	5400	3.6	2.1	12.8	0.056	6	M10	72
25	6500	11000	4500	5.5	3.6	20.3	0.125	6	M12	125
30	10000	17400	4000	6.9	6.2	28.9	0.219	8	M12	125
35	17000	28800	3500	11.2	9.8	46.6	0.488	8	M14	200
40	28500	48500	3100	16.3	15.9	70.9	1.011	8	M14	200
45	37000	62000	3000	20.2	21.4	90.7	1.482	10	M14	200
50	51000	86000	2500	27.0	29.5	123.5	2.474	8	M18	430
55	65000	110000	2300	32.6	40.2	159.1	3.714	14	M18	430
60	85000	145000	2100	32.0	52.8	184.4	4.810	14	M18	430
70	135000	240000	1850	43.8	85.5	280	9.907	16	M20	610
80	175000	300000	1750	64	117	362	14.214	18	M20	610
85	225000	380000	1650	75	148	446	20.320	20	M20	610
90	290000	500000	1550	101	183	568	31.036	20	M24	1000
100	380000	650000	1500	117	232	698	45.358	24	M24	1000
110	480000	820000	1250	140	295	940	73.880	20	M30	1700
120	620000	1050000	1150	188	430	1312	118.40	24	M30	1700
130	-	1450000	1000	319	603	1954	226.732	20	M36	2800
140	-	1950000	950	373	758	2391	328.567	24	M36	2800
150	-	2750000	850	475	983	3069	540.298	30	M36	2800

■ = Standard

¹⁾ Space required to align the coupling and replace the gasket

²⁾ Grease capacity for each coupling half

Ordering example:	GEARex® DA 80	d ₁ Ø300	d ₂ Ø300
	Type and size of coupling	Finish bore with keyway to DIN 6885 sheet 1	Finish bore with keyway to DIN 6885 sheet 1

Type DA

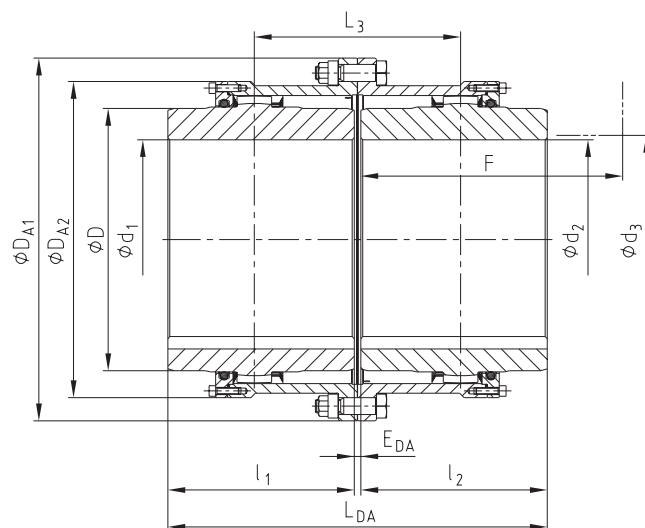

Type DB

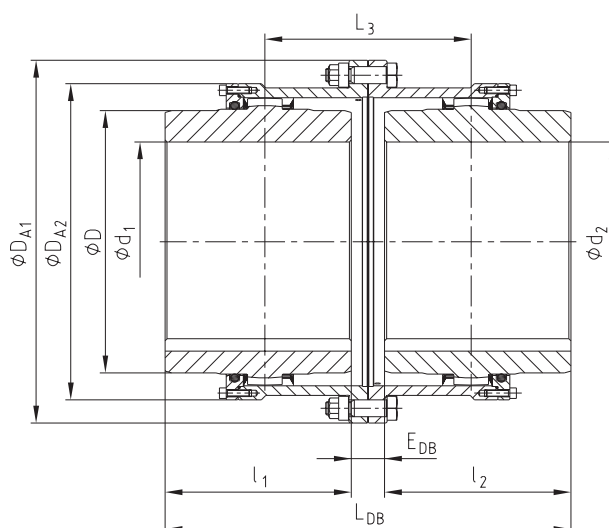

Type DAB

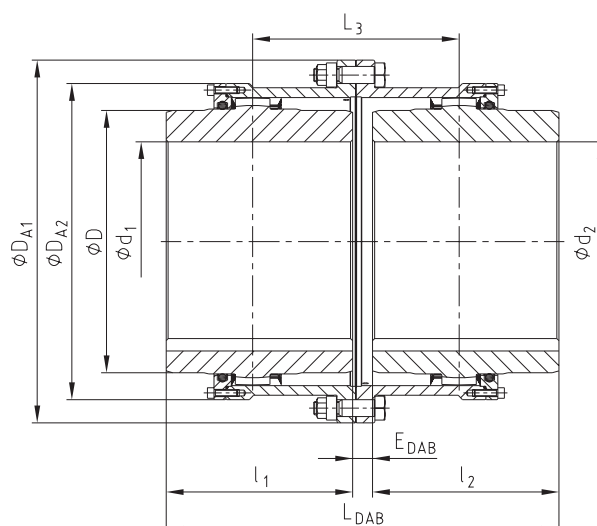

GEARex® FH and DH

All-steel gear couplings

Large shaft distance dimension, high power density

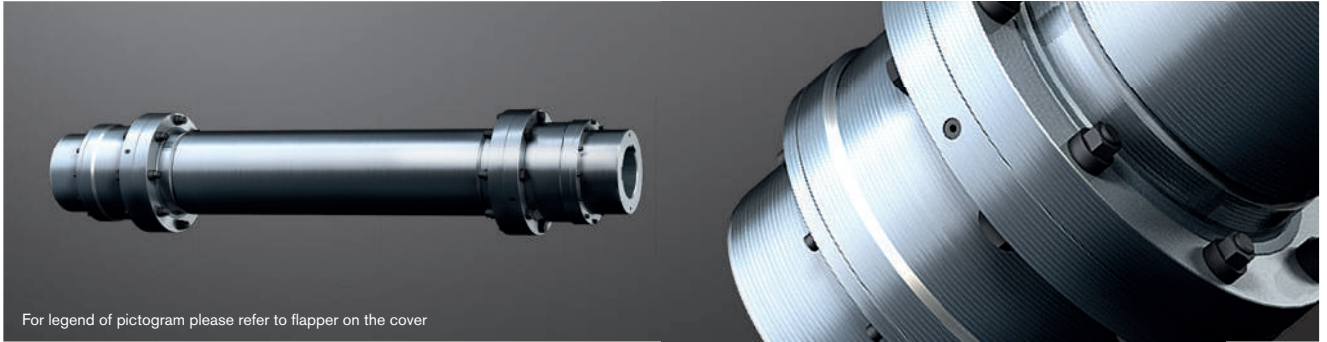

For legend of pictogram please refer to flapper on the cover

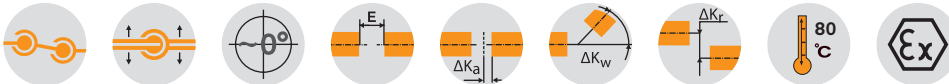

Dimensions																		
Size	Torque [Nm]		Pilot bore	Max. finish bore		Dimensions [mm]										Dowel screw (10.9)		Grease capacity [dm ³] ²⁾
	T _{KN}	T _{KN} (42CrMo4)		d ₁ , d ₂	l ₁ , l ₂	Hub lengthened max. l ₁ , l ₂	D	DA1 ³⁾	DA2 ³⁾	LH	EH	F ¹⁾	d ₃ ¹⁾	z	M	T _A [Nm]		
10 ⁴⁾	930	1580	26	50	43	105	67	111	84			74	52	6	M6	15	0.02	
15 ⁴⁾	2000	3300	26	64	50	115	87	152	107			84	68	8	M8	36	0.04	
20	3500	6300	31	80	62	130	108	178	130			104	85	6	M10	72	0.08	
25	6500	11000	38	98	76	150	130	213	158			123	110	6	M12	125	0.12	
30	10000	17400	44.5	112	90	170	153	240	182			148	130	8	M12	125	0.18	
35	17000	28800	46	133	105	185	180	280	214			172	150	8	M14	200	0.22	
40	28500	48500	52	158	120	215	214	318	250			192	175	8	M14	200	0.35	
45	37000	62000	80	172	135	245	233	347	274			216	190	10	M14	200	0.45	
50	51000	86000	80	192	150	295	260	390	309			241	220	8	M18	430	0.70	
55	65000	110000	90	210	175	300	283	425.5	334			275	250	14	M18	430	0.90	
60	85000	145000	100	232	190	305	312	457	365.5			316	265	14	M18	430	1.15	
70	135000	240000	100	276	220	310	371	527	425			360	300	16	M20	610	1.50	
80	175000	300000	140	300	280	-	394	545	475			340	310	18	M20	610	2.50	
85	225000	380000	160	325	292	-	430	585	515			352	330	20	M20	610	3.00	
90	290000	500000	180	350	305	-	464	640	560			365	360	20	M24	1000	4.00	
100	380000	650000	220	390	330	-	512	690	612			390	400	24	M24	1000	5.00	
110	480000	820000	220	420	350	-	560	765	665			410	420	20	M30	1700	6.00	
120	620000	1050000	260	450	420	-	608	825	720			480	470	24	M30	1700	7.50	
130	-	1450000	300	500	440	-	684	950	805			520	520	20	M36	2800	9.00	
140	-	1950000	380	550	460	-	750	1020	875			570	590	24	M36	2800	12.00	
150	-	2750000	460	630	520	-	850	1140	975			630	670	30	M36	2800	15.00	

■ = Standard

¹⁾ Space required to align the coupling and replace the gasket

²⁾ Grease capacity for each coupling half

³⁾ For dimension of type F see page 108. For type D see page 110.

⁴⁾ Only available as type F

Ordering example:	GEARex® FH 10	d ₁ Ø50	d ₂ Ø50	250
	Type and size of coupling	Finish bore with keyway to DIN 6885 sheet 1	Finish bore with keyway to DIN 6885 sheet 1	Shaft distance dimension E _H

Components

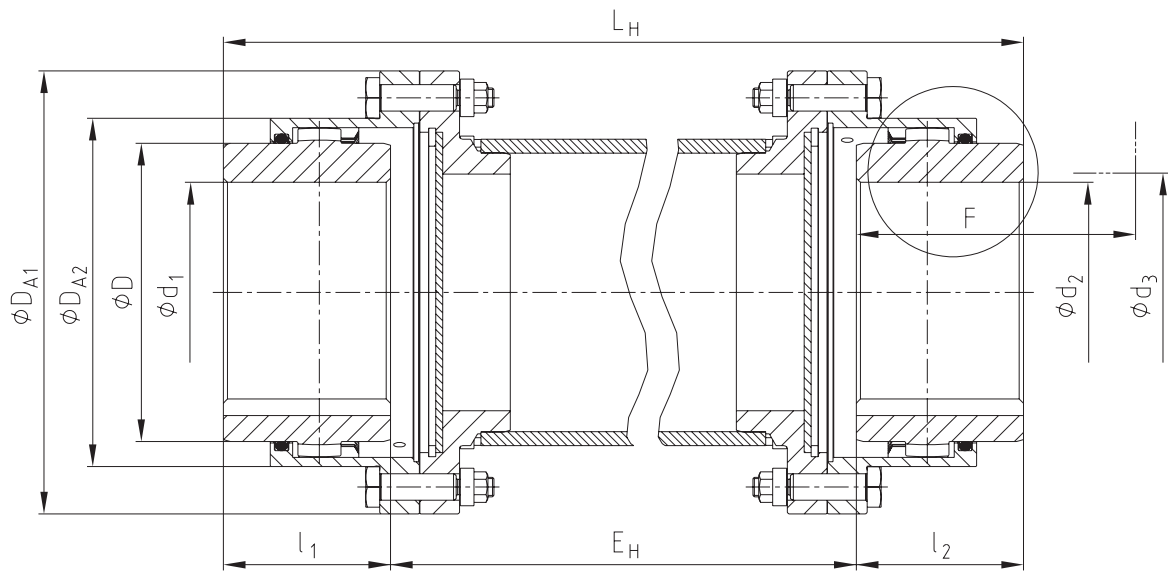

BoWex®

Types

Type FH

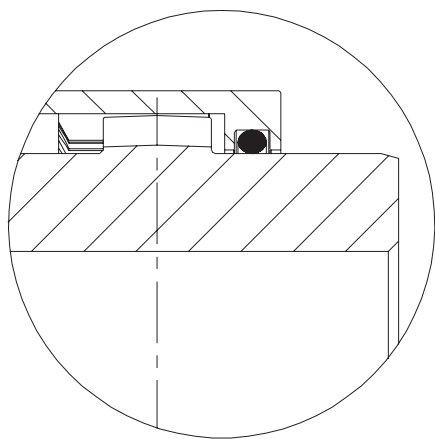

Type DH

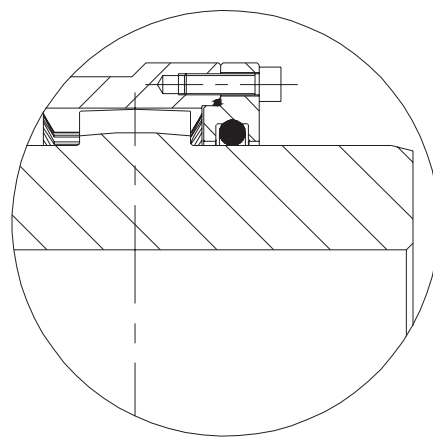

GEARex®

GEARex® FR and DR

All-steel gear couplings

Single-cardanic, high power density

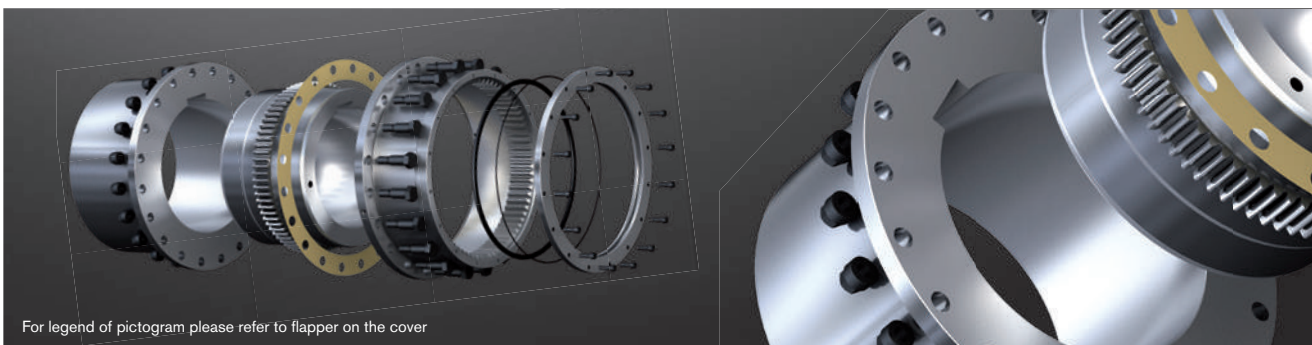

For legend of pictogram please refer to flapper on the cover



Dimensions																		
Size	Torque [Nm]		Max. finish bore		Dimensions [mm]									Dowel screw (10.9)		Grease capacity [dm ³]		
	T _{KN}	T _{KN} (42CrMo4)	d ₁	d ₄	l ₁ , l ₂	Hub lengthened max. l ₁ , l ₂	D	DA1 ²⁾	DA2 ²⁾	DF	LR	F ¹⁾	d ₃ ¹⁾	z	M		T _A [Nm]	
10 ³⁾	930	1580	50	60	43	105	67	111	84	84	88	74	52	6	M6	15	0.02	
15 ³⁾	2000	3300	64	78	50	115	87	152	107	107	103	84	68	8	M8	36	0.04	
20	3500	6300	80	95	62	130	108	178	130	130	127	104	85	6	M10	72	0.08	
25	6500	11000	98	115	76	150	130	213	158	158	157	123	110	6	M12	125	0.12	
30	10000	17400	112	135	90	170	153	240	182	182	185	148	130	8	M12	125	0.18	
35	17000	28800	133	155	105	185	180	280	214	214	216	172	150	8	M14	200	0.22	
40	28500	48500	158	185	120	215	214	318	250	250	244	192	175	8	M14	200	0.35	
45	37000	62000	172	200	135	245	233	347	274	274	276	216	190	10	M14	200	0.45	
50	51000	86000	192	225	150	295	260	390	309	309	305	241	220	8	M18	430	0.70	
55	65000	110000	210	245	175	300	283	425.5	334	334	356	275	250	14	M18	430	0.90	
60	85000	145000	232	265	190	305	312	457	365.5	365.5	386	316	265	14	M18	430	1.15	
70	135000	240000	276	310	220	310	371	527	425	425	450	360	300	16	M20	610	1.50	
80	175000	300000	300	340	280	-	394	545	475	462	570	340	310	18	M20	610	2.50	
85	225000	380000	325	370	292	-	430	585	515	500	597	352	330	20	M20	610	3.00	
90	290000	500000	350	400	305	-	464	640	560	546	623	365	360	20	M24	1000	4.00	
100	380000	650000	390	440	330	-	512	690	612	594	673	390	400	24	M24	1000	5.00	
110	480000	820000	420	480	350	-	560	765	665	647	710	410	420	20	M30	1700	6.00	
120	620000	1050000	450	520	420	-	608	825	720	700	852	480	470	24	M30	1700	7.50	
130	-	1450000	500	560	440	-	684	950	805	760	890	520	520	20	M36	2800	9.00	
140	-	1950000	550	610	460	-	750	1020	875	835	930	570	590	24	M36	2800	12.00	
150	-	2750000	630	690	520	-	850	1140	975	935	1055	630	670	30	M36	2800	15.00	

■ = Standard

¹⁾ Space required to align the coupling and replace the gasket

²⁾ For dimension type F see page 108. For type D see page 110.

³⁾ Only available as type F

Ordering example:	GEARex® FR 10	d ₁ Ø50	d ₄ Ø60
	Type and size of coupling	Finish bore with keyway to DIN 6885 sheet 1	Finish bore with keyway to DIN 6885 sheet 1

Components

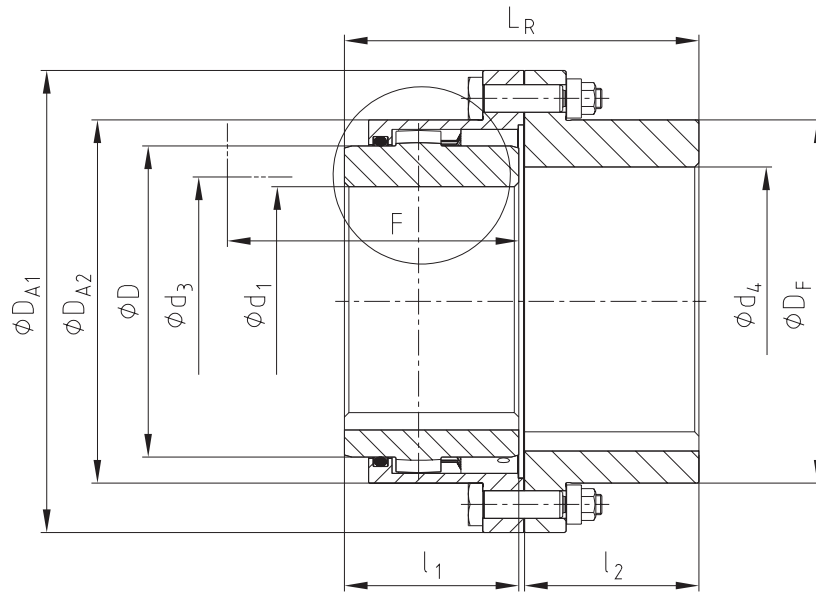

BoWex®

Types

Type FR

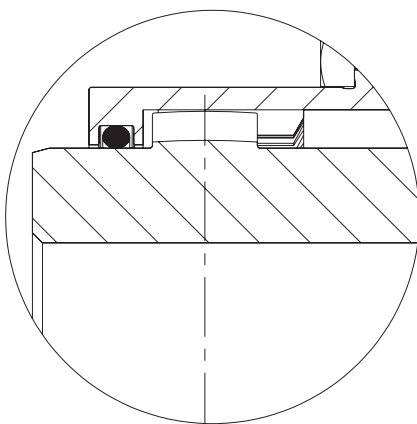

Type DR

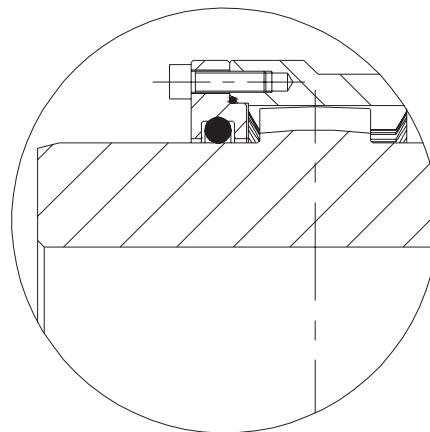

GEARex®

Displacements

Axial displacement

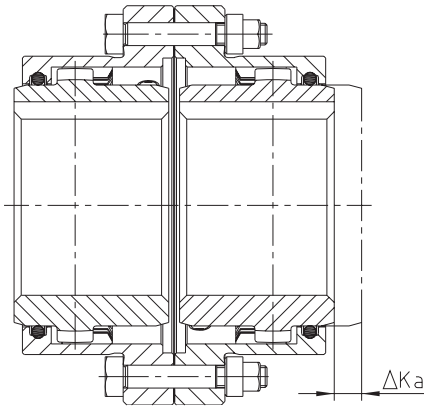

Radial displacement

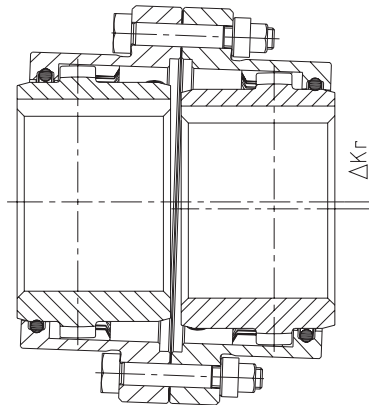

Angular displacement

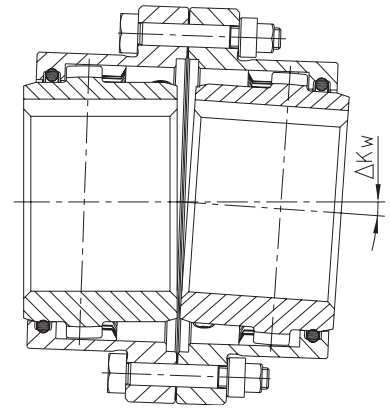

Displacements			
Size	Max. axial displacement ΔK_a [mm]	Max. permissible displacements ¹⁾	
		ΔK_r [mm]	ΔK_w [°]
10		± 0.4	
15		± 0.5	
20		± 0.6	
25	± 1.0	± 0.8	
30		± 1.0	
35		± 1.0	
40		± 1.2	
45		± 1.4	
50		± 1.6	
55	± 1.5	± 1.8	
60		± 2.0	0.5° each hub
70		± 2.2	
80		± 2.5	
85		± 2.8	
90	± 2.0	± 3.0	
100		± 3.2	
110		± 4.4	
120		± 5.5	
130		± 5.7	
140	± 2.5	± 6.0	
150		± 6.6	

¹⁾ The displacement figures are maximum figures which must not arise in parallel. If radial and angular displacements arise in parallel, the figures need to be reduced (see examples of calculation and diagramme).

Example 1:
 $\Delta K_r = 30\%$
 $\Delta K_w = 70\%$

Example 2:
 $\Delta K_r = 60\%$
 $\Delta K_w = 40\%$

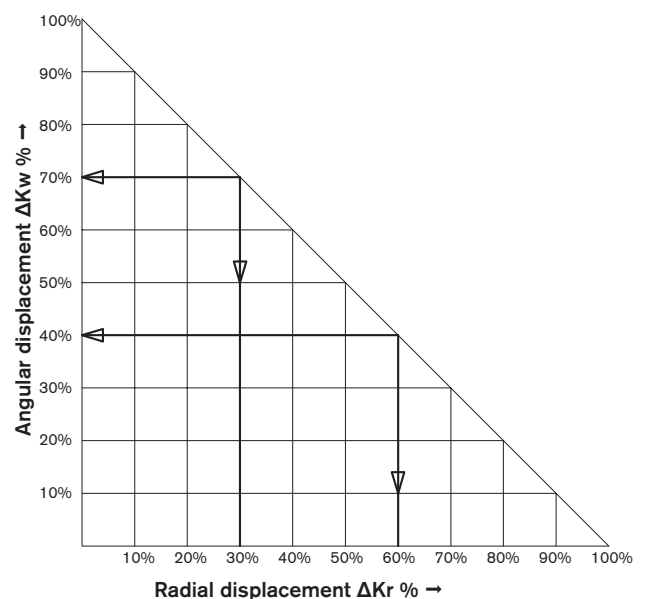

Flange dimensions in accordance with AGMA 9008-B00

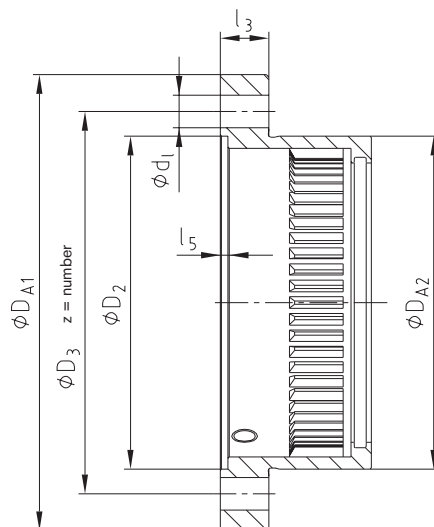

Flange dimensions								
Size	Dimensions [mm]							
	D_{A1}	D_{A2}	D_2	D_3	d_1	$z = \text{number}$	l_3	l_5
10	111	84	82	95.25	6.35	6	14	3
15	152	107	105	122.24	9.52	8	19	3
20	178	130	130	149.23	12.70	6	19	3
25	213	158	153	180.97	15.87	6	22	4
30	240	182	178	206.38	15.87	8	22	4
35	280	214	205	241.30	19.05	8	28.5	5
40	318	250	243	279.40	19.05	8	28.5	4
45	347	274	265	304.80	19.05	10	28.5	5.5
50	390	309	302	342.90	22.22	8	38	6
55	425.5	334	320	368.30	22.22	14	38	6
60	457	365.5	353	400.05	22.22	14	26	6
70	527	425	412	463.55	25.40	16	28.5	8

Other types

Type SD

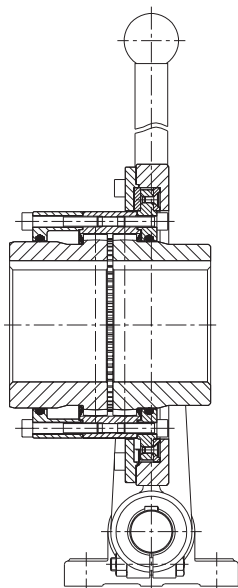

Type with brake disk

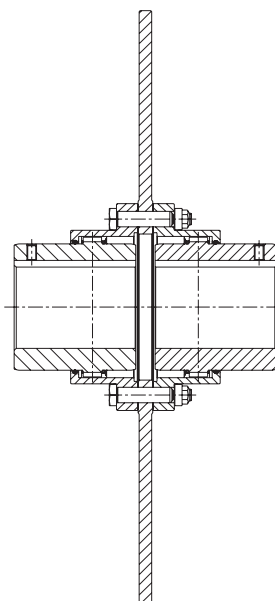

Type VD (vertical assembly)

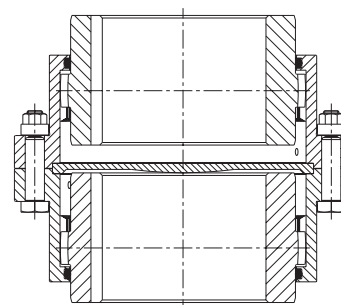



Backlash-free servo couplings

Types and operating description 120

ROTEX® GS

Structure and operation	122
Technical data and displacements	124
Types of hubs	128
Basic programme	129
Standard types	130
Type Compact	132
Type clamping ring hubs light	134
Type clamping ring hubs steel	135
Type P according to DIN 69002	136
Type HP	138
Type P with ETP® clamping set	140
Type with expansion hub for hollow shaft connections	141
Type A-H drop-out center design couplings	142
Type DKM (double-cardanic)	144
Intermediate shaft coupling	146

KTR-STOP® NC

Safety clamping and braking system	150
------------------------------------	-----

TOOLFLEX®

Technical description	152
Types of hubs	153
Type S with thread for setscrew	154
Type M with thread for setscrew	155
Type S with clamping hubs	156
Type M with clamping hubs	158
Type KN	160
Type PI	162
Type CF	164
Type S-H / M-H	166
Type ZR	168

RADEX®-NC

Technical description	170
Standard types	171
High-Torque hub design 2.5	172
High-Torque hub design 3.5	173
High-Torque hub design 6.5	174

COUNTEX®

Standard types	176
----------------	-----

ROTEX® GS



TOOLFLEX®



RADEX®-NC







COUNTEX®



BACKLASH-FREE SERVO COUPLINGS

TYPES AND OPERATING DESCRIPTION

Properties of backlash-free couplings

				
Product	ROTEX® GS	TOOLFLEX®	RADEX®-NC	COUNTEX®
Type	Jaw coupling	Metal bellow-type coupling	Servo lamina coupling	Shaft encoder coupling
Features				
Backlash-free	●	●	●	●
Torsionally rigid		●	●	●
Damping vibrations	●			
Maintenance-free	●	●	●	●
Axial plug-in	●	Optionally		●
Compensating for misalignment	●	●	●	●
Electric insulation	●			●
Fail-safe	●			
Shear type		●		
Special features				
Applications	Backlash-free drives			
Core industries	Machine tools, automation technology, drive technology, medical technology, packaging technology	Drive technology, automation technology, medical technology, packaging technology, machine tools	Automation technology, drive technology, packaging technology, machine tools, medical technology	Automation technology, drive technology, medical technology
Applications	Main spindles Control & positioning technology (screw drives with incline $s < 40$, otherwise review by KTR) Gearboxes (for average to high transmission $i \geq 7$) Measuring and testing technology Miniature drives	Gearboxes (transmissions $i < 7$) Miniature drives Control & positioning technology (screw drives with incline $s \geq 40$)	Gearboxes (transmissions $i < 7$) Measuring & testing technology Miniature drives Control & positioning technology (screw drives with incline $s \geq 40$)	Measuring & control technology Miniature drives
Variation of components	very high	average	low	low
Torque range T_{KN} [Nm]				
Min.	0.2	0.1	2.5	0.3
Max.	5,850	600	2000	1.0
Max. circumferential speed v [m/s]				
Steel	depending on hub type up to 40	depending on hub type up to 40	35	-
	80 (type P)			
	175 (type HP)			
Aluminium	depending on hub type up to 50		depending on hub type up to 75	40
Torsion spring stiffness C_T [Nm/rad]				
Up to	1,308,850	322,740	240,000	235
Radial spring stiffness C_R [N/mm]				
Up to	20,290	1,365		70
Spiders / bellow / laminas / spacer				
Material	Polyurethane, Hytrel	Stainless steel	Stainless steel	PEEK
Elastomer hardness	flexible to torsionally rigid	-	-	torsionally rigid
Temperature range [°C] min./max.	-50/+120	-30/+100 (bonded)	-30/+200	-40/+160
		-30/+200 (flanged/welded)		
Geometries				
Design	compact	compact, short	compact, short	short
Mass moment of inertia	low	low	low	low
Shaft distance dimension	average	average	average	low
Shaft-hub-connection				
Positive-locking	●	Optionally	Optionally	Optionally
Non-positive (frictionally engaged)	●	●	●	●

● ≈ Standard

BACKLASH-FREE SERVO COUPLINGS TYPES AND OPERATING DESCRIPTION

Product finder of backlash-free couplings

Product	ROTEX® GS	TOOLFLEX®	RADEX®-NC	COUNTEX®
Type	Jaw coupling	Metal bellow-type coupling	Servo lamina coupling	Shaft encoder coupling
Types (extract)				
Elastomers can be radially disassembled » with no need of displacing driving/driven side	A-H	-	-	-
Intermediate shaft type » bridging larger shaft distances	ZR1, ZR2, ZR3	-	-	-
Shaft-to-shaft connection	Standard	Standard	Standard	Standard
Flange-to-shaft connection	CFN, DFN, CF-DKM	CF	-	-
Flange-to-flange connection » particularly short mounting lengths	Optionally	Optionally	-	-
Single-cardanic	Standard	-	EK	-
Double-cardanic » compensating for big displacements » lower restoring forces	DKM	Standard	DK	Standard
Certifications				
ATEX		•	•	•
Clean room		•	•	

• ≈ Standard

Torsion angle

The diagramme alongside this text explains the influence of ROTEX®, ROTEX® GS, RADEX®-NC and TOOLFLEX® couplings on backlash and torsion angle. Due to the high torsion spring stiffness of RADEX®-NC and TOOLFLEX® the torsion angle is very low under torque. However, contrary to the flexible ROTEX® and the backlash-free ROTEX® GS damping of torsional vibrations etc. is not possible.

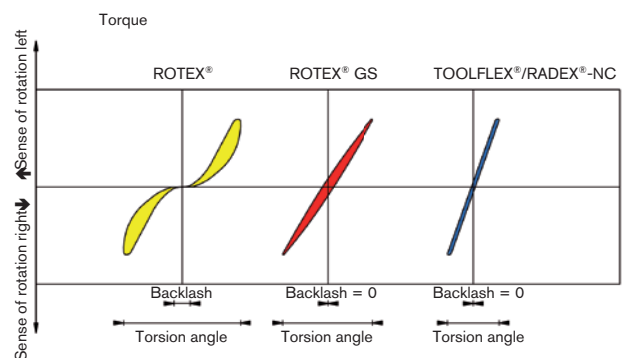

The KTR-STOP® NC series is a passive clamping and braking system. It serves for generating a clamping/braking force respectively a clamping/braking torque on a cylindrical piston rod or shaft. This results in a deceleration of the rotary motion respectively keeping at standstill. For further details please refer to page 150/151.

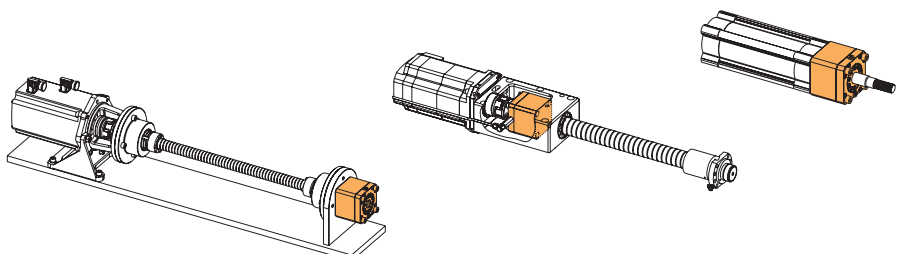

ROTEX® GS

Backlash-free jaw couplings

Technical description



ROTEX® GS is a three-part, axial plug-in coupling backlash-free under prestress. It impresses even with critical applications by its backlash-free power transmission, its stiffness which is each adapted to the application and its optimum damping of vibrations. Using this principle provides for significant options of assembly optimizing the assembly times in production.

The straight spline of the spider mounted under prestress results in a lower surface pressure and consequently higher stiffness of the coupling system. The flexible teeth compensating for misalignment are radially supported in the internal diameter by means of a web. This avoids too high internal or external deformation with high acceleration or high speeds. This is vital for a smooth operation and long service life of the coupling.

The pegs on the spider arranged reciprocally prevent a contact of the spider on the hubs over the full surface. Observing the distance dimension E ensures the ability of the coupling to compensate for displacements.

By observing the gap dimension „s“ the electrical insulation is ensured, as well as a high service life of the coupling. This fact is gaining more and more importance, due to the increasing precision of shaft encoders and the existing demand for electromagnetic compatibility (EMC).

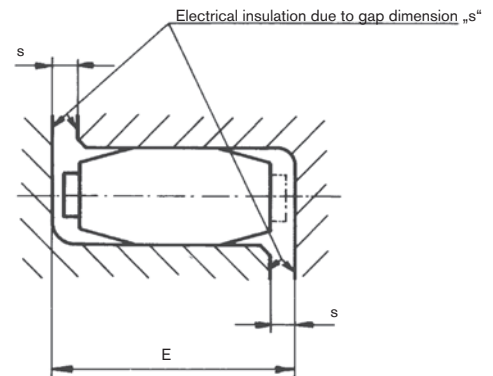
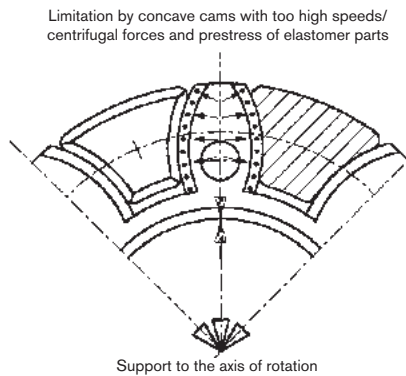

Technical description

ROTEX® GS HP is a backlash-free, axial plug-in, flexible jaw coupling developed for high-speed drives.

In contrast to the ROTEX® GS coupling this type has got individual elastomers instead of a complete spider.

This allows to design the hubs as a completely enclosed shape so that both the cam section and the pocket part feature higher stiffness against loads in direction of rotation (torque shocks), but also in tangential direction (centrifugal force). The elastomers are embedded in the pocket part such that the high loads resulting from centrifugal forces do not have any negative influence on them and consequently do not have any negative influence on the overall drive system.

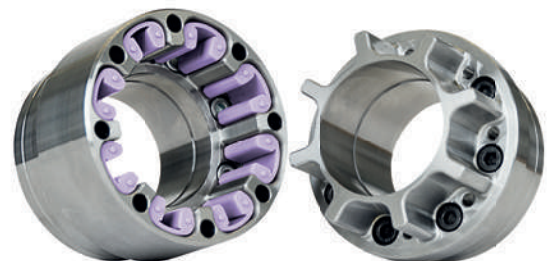

Instead of torques with circumferential speeds of a maximum of 100 m/s for ROTEX® GS P couplings, circumferential speeds up to 175 m/s can be reached with the new ROTEX® GS HP system.







ROTEX® GS

Backlash-free jaw couplings

Spiders

The flexible spiders for the GS series are available in five different kinds of Shore hardness, injected in different colours, either as a torsionally soft or hard material. These five spiders with different kinds of Shore hardness allow to easily adjust the ROTEX® GS with regard to torsional stiffness and the vibration behaviour to the individual conditions of an application. The flexible prestress varies depending on the coupling size, the spiders/material and the production tolerances. Resulting from it is the axial plug-in force starting from low as a close sliding fit or with torsionally soft spider to heavy with big prestress or torsionally rigid spider (see mounting instruction KTR-N 45510 at www.ktr.com).

Along with an increasing hardness of the spider the torques to be transmitted and the stiffness of the spider increase, too. Along with reduced hardness of the spider the ability of compensating for displacements and damping the spider is increased.

Features						
Description of spider Hardness [Shore]	Marking Colour	Material	Perm. temperature range [°C]		Available for coupling size	Typical applications
			Permanent temperature	Max. temperature (short-time)		
80 ShA-GS		Polyurethane	-50 to +80	-60 to +120	Size 5 to 24	- drives of electric measuring systems
92 ShA-GS		Polyurethane	-40 to +90	-50 to +120	Size 5 to 55	- drives of electric measuring and control systems - main spindle drives
98 ShA-GS		Polyurethane	-30 to +90	-40 to +120	Size 5 to 90	- Positioning drives - main spindle drives - high load
98 ShA-GS 52 ShD-GS		Polyurethane	-30 to +90	-40 to +120	Size 24 to 55 (for ROTEX® GS HP only)	- HSC main spindle drives - test benches with severely high speeds
64 ShD-H-GS 64 ShD-GS		Hytrel	-50 to +120	-60 to +150	Size 7 to 38	- planetary gears/backlash-free gears - higher torsion spring stiffness/high ambient temperatures
		Polyurethane	-20 to +110	-30 to +120	Size 42 to 90	- higher load - higher torsion spring stiffness
72 ShD-H-GS 72 ShD-GS		Hytrel	-50 to +120	-60 to +150	Size 24 to 38	- very high torsion spring stiffness/high ambient temperature - very high load
		Polyurethane	-20 to +110	-30 to +120	Size 42 to 90	- very high torsion spring stiffness - very high load

Degree of hardness

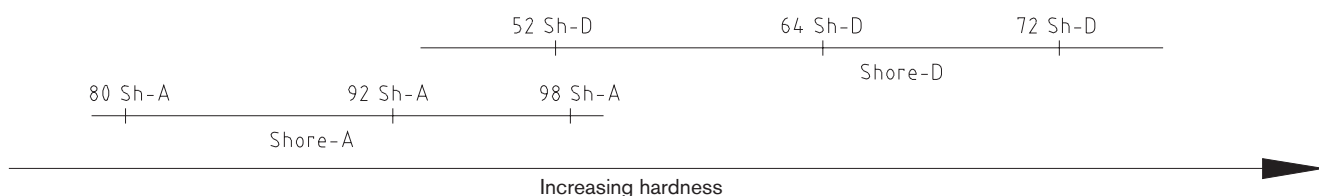

Spider material	Polyurethane			Hytrel
Degree of hardness	92 Shore A	98 Shore A	64 Shore D	64 Shore D
Relative damping ψ [-] ¹⁾	0.80	0.80	0.75	0.60
Resonance factor V_R [-] ¹⁾	7.90	7.90	8.50	10.5

¹⁾ Special figures apply for ROTEX® GS HP, please contact us.

Advice

- Feather keyways available from a bore $\geq \varnothing 6$. Feather keyways according to DIN 6885 sheet 1, tolerance JS9.
- Finish bore tolerance H7 (except for clamping hubs), from $\varnothing 55$ G7 with clamping ring hubs
- Finish bore tolerance H6 for ROTEX® GS P and ROTEX® GS HP
- Recommended insertion dimension of shafts into coupling hubs: l_1/l_2 ; for clamping ring hubs the minimum insertion dimension l_3 applies
- Spider with bore available on request. Please specify in the order as shown in the example on page 130.

Use in potentially explosive atmospheres

ROTEX® GS couplings are suitable for power transmission in drives in potentially explosive atmospheres. The couplings are assessed and approved according to EU directive 2014/34/EU as units of category 2G/2D and thus suitable for the use in potentially explosive atmospheres of zone 1, 2, 21 and 22. Please read through our information included in the respective Type Examination Certificate and the operating and assembly instructions at www.ktr.com.

Selection: If used in potentially explosive atmospheres the clamping ring hubs (clamping hubs without feather keyway only for use in category 3) must be selected in a way that there is a minimum safety factor of $s = 2$ between the peak torque of the machine including all operating parameters and the nominal torque and frictional locking torque of the coupling.

ROTEX® GS

Backlash-free jaw couplings

Technical data

Size	Spider GS Shore hardness	Shore scale	Max. speed [rpm] for type					DKM	Torque [Nm]		Static torsion spring stiffness ¹⁾ [Nm/rad]	Dynamic torsion spring stiffness ¹⁾ [Nm/rad]	Radial torsion spring stiffness C _r [N/mm]	Weight [kg]		Mass moment of inertia J [kgm ²]	
			2.0 / 2.1 2.5 / 2.6	2.8 2.9	1.0 1.1	6.0 light ²⁾	6.0 P ²⁾		T _{KN}	T _{K max}				Each hub ⁵⁾	Spider	Each hub ⁵⁾	Spider
5	70	A	38000	38000	47700			57300	0.2	0.3	1.78	5	43	0.001	0.2 x 10 ⁻³	0.015 x 10 ⁻⁶	0.002 x 10 ⁻⁶
	80	A							0.3	0.6	3.15	10	82				
	92	A							0.5	1.0	5.16	16	154				
	98	A							0.9	1.7	8.3	25	296				
7	80	A	27000	27000	34100			40900	0.7	1.4	8.6	26	114	0.003	0.7 x 10 ⁻³	0.085 x 10 ⁻⁶	0.01 x 10 ⁻⁶
	92	A							1.2	2.4	14.3	43	219				
	98	A							2.0	4.0	22.9	69	421				
	64	D							2.4	4.8	34.3	103	630				
8	80	A	23800						0.7	1.4	8.8	27	117	0.003	0.5 x 10 ⁻³	0.117 x 10 ⁻⁶	0.0124 x 10 ⁻⁶
	98	A							2.0	4.0	23.5	71	433				
	64	D							2.4	4.8	35.3	106	648				
9	80	A	19000	19000	23800			28600	1.8	3.6	17.2	52	125	0.01	1.7 x 10 ⁻³	0.48 x 10 ⁻⁶	0.085 x 10 ⁻⁶
	92	A							3.0	6.0	31.5	95	262				
	98	A							5.0	10.0	51.6	155	518				
	64	D							6.0	12.0	74.6	224	739				
12	80	A	15200	15200	19100			22900	3.0	6.0	84.3	252	274	0.02	2.3 x 10 ⁻³	1.5 x 10 ⁻⁶	0.139 x 10 ⁻⁶
	92	A							5.0	10.0	160.4	482	470				
	98	A							9.0	18.0	240.7	718	846				
	64	D							12.0	24.0	327.9	982	1198				
13	80	A	12700						3.6	7.2	111	330	359	0.01	2.0 x 10 ⁻³	1.1 x 10 ⁻⁶	0.155 x 10 ⁻⁶
	98	A							11.0	22.0	316	941	1109				
	64	D							14.5	29.0	430	1287	1570				
14	80	A	12700	12700	15900	32000	47700	19100	4.0	8.0	60.2	180	153	0.02	4.7 x 10 ⁻³	2.8 x 10 ⁻⁶	0.509 x 10 ⁻⁶
	92	A							7.5	15.0	114.6	344	336				
	98	A							12.5	25.0	171.9	513	654				
	64	D							16.0	32.0	234.2	702	856				
16	80	A	12000						5.0	10.0	157	471	400	0.02	3.6 x 10 ⁻³	2.8 x 10 ⁻⁶	0.435 x 10 ⁻⁶
	98	A							15.0	30.0	450	1341	1710				
	64	D							19.0	38.0	612	1835	2238				
19	80	A	9550	9550	11900	24000	35800	14300	6.0	12.0	618	1065	582	0.09	7.6 x 10 ⁻³	19.5 x 10 ⁻⁶	1.35 x 10 ⁻⁶
	92	A							12.0	24.0	1090	1815	1120				
	98	A							21.0	42.0	1512	2540	2010				
	64	D							26.0	52.0	2560	3810	2930				
24	92	A	6950	10400	8650	17000	26000	10400	35	70	2280	4010	1480	0.2	0.02	81.9 x 10 ⁻⁶	6.7 x 10 ⁻⁶
	98	A							60	120	3640	5980	2560				
	64	D							75	150	5030	10896	3696				
	72 ³⁾	D							97	194	9944	17095	5799				
28	92	A	5850	8800	7350	15000	22000	8800	95	190	4080	6745	1780	0.3	0.03	184.2 x 10 ⁻⁶	14.85 x 10 ⁻⁶
	98	A							160	320	6410	9920	3200				
	64	D							200	400	10260	20177	4348				
	72 ³⁾	D							260	520	21526	36547	7876				
38	92	A	4750	7150	5950	12000	17900	7150	190	380	6525	11050	2350	0.6	0.05	542.7 x 10 ⁻⁶	39.4 x 10 ⁻⁶
	98	A							325	650	11800	17160	4400				
	64	D							405	810	26300	40335	6474				
	72 ³⁾	D							525	1050	44584	71180	11425				
42	92	A	4000		5000	10000 8050 ⁴⁾	15000	6000	265	530	10870	15680	2430	2.4	0.08	2802 x 10 ⁻⁶	85 x 10 ⁻⁶
	98	A							450	900	21594	37692	5570				
	64	D							560	1120	36860	69825	7270				
	72 ³⁾	D							728	1456	58600	93800	9766				
48	92	A	3600		4550	9100 7200 ⁴⁾	13600	5450	310	620	12968	18400	2580	3.3	0.09	4709 x 10 ⁻⁶	135 x 10 ⁻⁶
	98	A							525	1050	25759	45620	5930				
	64	D							655	1310	57630	99750	8274				
	72 ³⁾	D							852	1704	80000	136948	11359				
55	92	A	3150		3950	6350 ⁴⁾	11900	4750	410	820	15482	21375	2980	5.1	0.12	9460 x 10 ⁻⁶	229 x 10 ⁻⁶
	98	A							685	1370	42117	61550	6686				
	64	D							825	1650	105730	130200	9248				
	72 ³⁾	D							1072	2144	150000	209530	12762				
65	98	A	2800		3500	5650 ⁴⁾	11000		940	1880	48520	71660	6418	6.7	0.2	15143 x 10 ⁻⁶	437 x 10 ⁻⁶
	64	D							1175	2350	118510	189189	8870				
	72 ³⁾	D							1527	3054	160000	310000	11826				
75	98	A	2350		2950	4750 ⁴⁾	8950		1920	3840	79150	150450	8650	10.5	0.3	32750 x 10 ⁻⁶	1179 x 10 ⁻⁶
	64	D							2400	4800	182320	316377	11923				
	72 ³⁾	D							3120	6240	360540	586429	16454				
90	98	A	1900		2380	3800 ⁴⁾	7150		3600	7200	204500	302900	10700	18.2	0.6	87099 x 10 ⁻⁶	3362 x 10 ⁻⁶
	64	D							4500	9000	429450	908700	14700				
	72 ³⁾	D							5850	11700	847440	1308852	20290				

¹⁾ Static and dynamic torsion spring stiffness with 0.5 x T_{KN}

²⁾ For higher speeds see ROTEX® GS HP

³⁾ When using the spider 72 ShD, we recommend to use hubs made of steel

⁴⁾ Clamping ring hubs 6.0 made of steel

⁵⁾ Hubs with an average bore type 1.0

The coupling has to be dimensioned in a way that the permissible coupling load is not exceeded during any operating condition (see coupling selection on page 22 et seqq.).

The torques specified T_{KN}/T_{K max} refer to the spider. The shaft-hub-connection needs to be inspected by the customer.

For technical data of type HP see page 138.

ROTEX® GS

Backlash-free jaw couplings

Notes for displacements

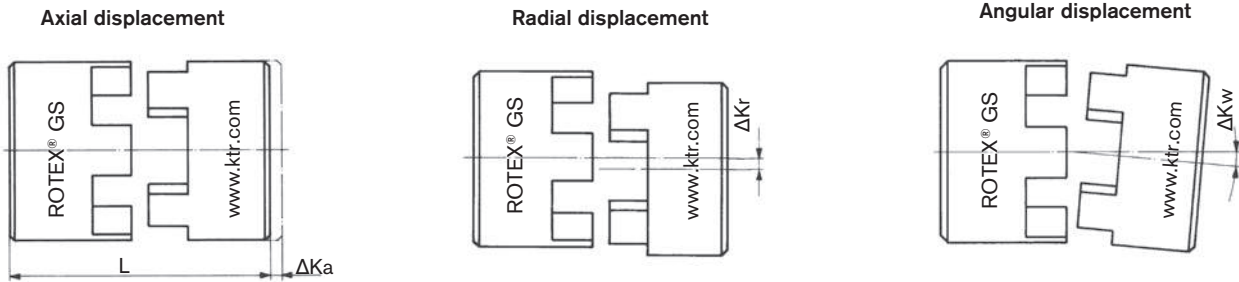

Due to its design the ROTEX® GS is able to absorb axial, angular and radial displacement, without causing any wear or premature failure of the coupling. As the spider is only stressed under pressure it is ensured that the coupling will remain backlash-free even after a longer operation period.

As an example, axial displacement may be generated by different tolerances of the connecting elements with assembly or by alteration of the shaft lengths if fluctuation of temperature occurs. As the shaft bearings usually cannot be axially stressed to a big extent, it is the task of the coupling to compensate for this axial displacement and keep the reaction forces low.

In case of pure angular displacement the imaginary bisecting lines of the shafts intersect in the center of the coupling. Within a permissible range this displacement can be absorbed by the coupling without extensive restoring forces being generated.

Radial displacement results from parallel displacement of the shafts towards each other, caused by different tolerances on the centerings or by mounting the power packs on different levels. Due to the kind of displacement the largest restoring forces are generated here, consequently causing the highest stresses on adjacent components.

In case of larger displacements (especially radial displacements) the ROTEX® GS type DKM should be used in order to avoid excessive restoring forces.

The permissible displacement figures of the flexible ROTEX® GS couplings specified are general standard values taking into account the load of the coupling up to the rated torque TKN of the coupling and an ambient temperature of +30 °C. The displacement figures may only be used one by one, if they appear simultaneously, they must be limited in proportion. The ROTEX® GS couplings are able to compensate for axial, radial and angular displacements. Careful and accurate alignment of the shafts increases the service life of the coupling.

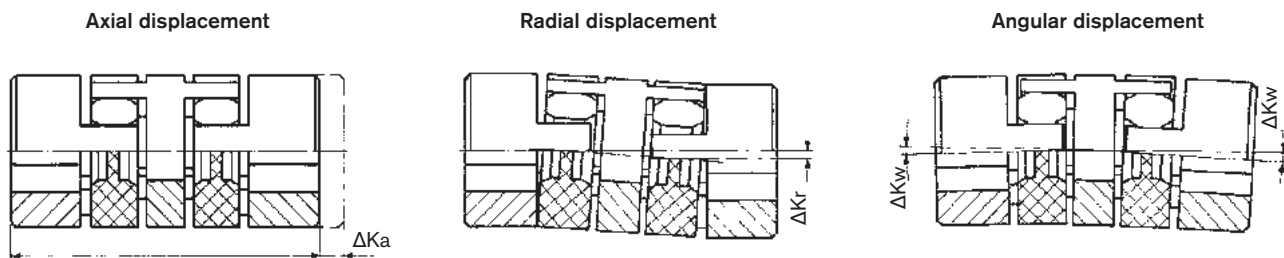

Shaft misalignment of ROTEX® GS type DKM

This design reduces the restoring forces arising with radial displacement to a minimum, due to the double-jointed operation, additionally the coupling is able to compensate for higher axial and angular misalignment.

ROTEX® GS

Backlash-free jaw couplings

Displacements

Displacements							
Size	Spider GS	Standard displacements			DKM displacements		
		Axial $\Delta K_a^{1)}$ [mm]	Radial ΔK_r [mm]	Angular ΔK_w [degree]	Axial $\Delta K_a^{1)}$ [mm]	Radial ΔK_r [mm]	Angular ΔK_w [degree]
5	70 ShA		0.14	1.2°		0.17	1.2°
	80 ShA	+0.4	0.12	1.1°	+0.4	0.15	1.1°
	92 ShA	-0.2	0.06	1.0°	-0.4	0.14	1.0°
	98 ShA		0.04	0.9°		0.13	0.9°
7	80 ShA		0.15	1.1°		0.23	1.1°
	92 ShA	+0.6	0.10	1.0°	+0.6	0.21	1.0°
	98 ShA	-0.3	0.06	0.9°	-0.6	0.19	0.9°
	64 ShD		0.04	0.8°		0.17	0.8°
8	80 ShA	+0.6	0.15	1.1°			
	98 ShA		0.08	0.9°	—	—	—
	64 ShD	-0.5	0.06	0.8°			
9	80 ShA		0.19	1.1°		0.29	1.1°
	92 ShA	+0.8	0.13	1.0°	+0.8	0.26	1.0°
	98 ShA	-0.4	0.08	0.9°	-0.8	0.24	0.9°
	64 ShD		0.05	0.8°		0.21	0.8°
12	80 ShA		0.20	1.1°		0.35	1.1°
	92 ShA	+0.9	0.14	1.0°	+0.9	0.32	1.0°
	98 ShA	-0.4	0.08	0.9°	-0.9	0.29	0.9°
	64 ShD		0.05	0.8°		0.25	0.8°
13	80 ShA	+0.9	0.20	1.1°			
	98 ShA		0.08	0.9°	—	—	—
	64 ShD	-0.8	0.05	0.8°			
14	80 ShA		0.21	1.1°		0.40	1.1°
	92 ShA	+1.0	0.15	1.0°	+1.0	0.37	1.0°
	98 ShA	-0.5	0.09	0.9°	-1.0	0.33	0.9°
	64 ShD		0.06	0.8°		0.29	0.8°
16	80 ShA	+1.0	0.21	1.1°			
	98 ShA		0.10	0.9°	—	—	—
	64 ShD	-0.8	0.08	0.8°			
19	80 ShA		0.15	1.1°		0.49	1.1°
	92 ShA	+1.2	0.10	1.0°	+1.2	0.45	1.0°
	98 ShA	-0.5	0.06	0.9°	-1.0	0.41	0.9°
	64 ShD		0.04	0.8°		0.36	0.8°
24	92 ShA		0.14	1.0°		0.59	1.0°
	98 ShA	+1.4	0.10	0.9°	+1.4	0.53	0.9°
	64 ShD	-0.5	0.07	0.8°	-1.0	0.47	0.8°
	72 ShD		0.04	0.7°		0.42	0.7°
28	92 ShA		0.15	1.0°		0.66	1.0°
	98 ShA	+1.5	0.11	0.9°	+1.5	0.60	0.9°
	64 ShD	-0.7	0.08	0.8°	-1.4	0.53	0.8°
	72 ShD		0.05	0.7°		0.46	0.7°
38	92 ShA		0.17	1.0°		0.77	1.0°
	98 ShA	+1.8	0.12	0.9°	+1.8	0.69	0.9°
	64 ShD	-0.7	0.09	0.8°	-1.4	0.61	0.8°
	72 ShD		0.06	0.7°		0.54	0.7°
42	92 ShA		0.19	1.0°		0.84	1.0°
	98 ShA	+2.0	0.14	0.9°	+2.0	0.75	0.9°
	64 ShD	-1.0	0.10	0.8°	-2.0	0.67	0.8°
	72 ShD		0.07	0.7°		0.59	0.7°
48	92 ShA		0.23	1.0°		0.91	1.0°
	98 ShA	+2.1	0.16	0.9°	+2.1	0.82	0.9°
	64 ShD	-1.0	0.11	0.8°	-2.0	0.73	0.8°
	72 ShD		0.08	0.7°		0.64	0.7°
55	92 ShA		0.24	1.0°		1.01	1.0°
	98 ShA	+2.2	0.17	0.9°	+2.2	0.91	0.9°
	64 ShD	-1.0	0.12	0.8°	-2.0	0.81	0.8°
	72 ShD		0.09	0.7°		0.71	0.7°
65	98 ShA	+2.6	0.18	0.9°			
	64 ShD		0.13	0.8°	—	—	—
	72 ShD	-1.0	0.10	0.7°			
75	98 ShA	+3.0	0.21	0.9°			
	64 ShD		0.15	0.8°	—	—	—
	72 ShD	-1.5	0.11	0.7°			
90	98 ShA	+3.4	0.23	0.9°			
	64 ShD		0.17	0.8°	—	—	—
	72 ShD	-1.5	0.13	0.7°			

¹⁾ The Ka figures specified above have to be added to the length of the respective coupling type.

The displacement figures may only be used one by one, if they appear simultaneously, they must be limited in proportion. Care should be taken to maintain the distance dimension E accurately in order to allow for axial clearance of the coupling while in operation. Detailed mounting instructions are shown on our homepage www.ktr.com.

For technical data of type HP see page 134.

ROTEX® GS

Backlash-free jaw couplings

Displacements of intermediate shaft coupling

Displacements of intermediate shaft couplings			
ROTEX® GS size (with 98 ShA-GS)	Axial ΔK_a [mm]	Radial ΔK_r ¹⁾ [mm]	Angular ΔK_w [degree]
14	+1.0	15	0.9°
	-1.0		
19	+1.2	14	0.9°
	-1.0		
24	+1.4	14	0.9°
	-1.0		
28	+1.5	14	0.9°
	-1.4		
38	+1.8	14	0.9°
	-1.4		
42	+2.0	14	0.9°
	-2.0		
48	+2.1	13	0.9°
	-2.0		
55	+2.2	13	0.9°
	-2.0		
65	+2.6	13	0.9°
	-2.0		

¹⁾ Radial displacements based on a coupling length $L_{ZR} = 1000$ mm

Calculation of overall torsion spring stiffness:

$$C_{tot.} = 2 \cdot \frac{1}{C_1} + \frac{L_{pipe}}{C_2} \quad [\text{Nm/rad}]$$

$$\text{with } L_{pipe} = \frac{L_{ZR} - 2 \cdot L}{1000} \quad [\text{m}]$$

C_1 = torsion spring stiffness for spider see page 120
 C_2 = from table on page 146 - 148

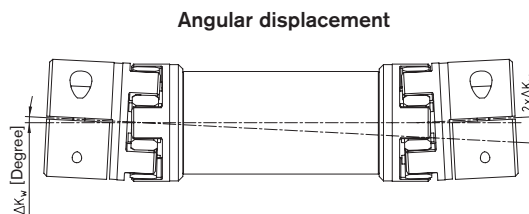
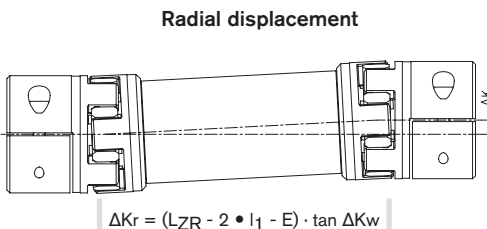
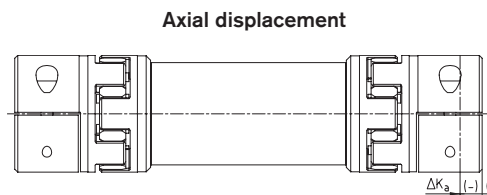

ROTEX® GS

Backlash-free
servo couplings

TOOLFLEX®

Chart of critical bending speeds for type ZR3

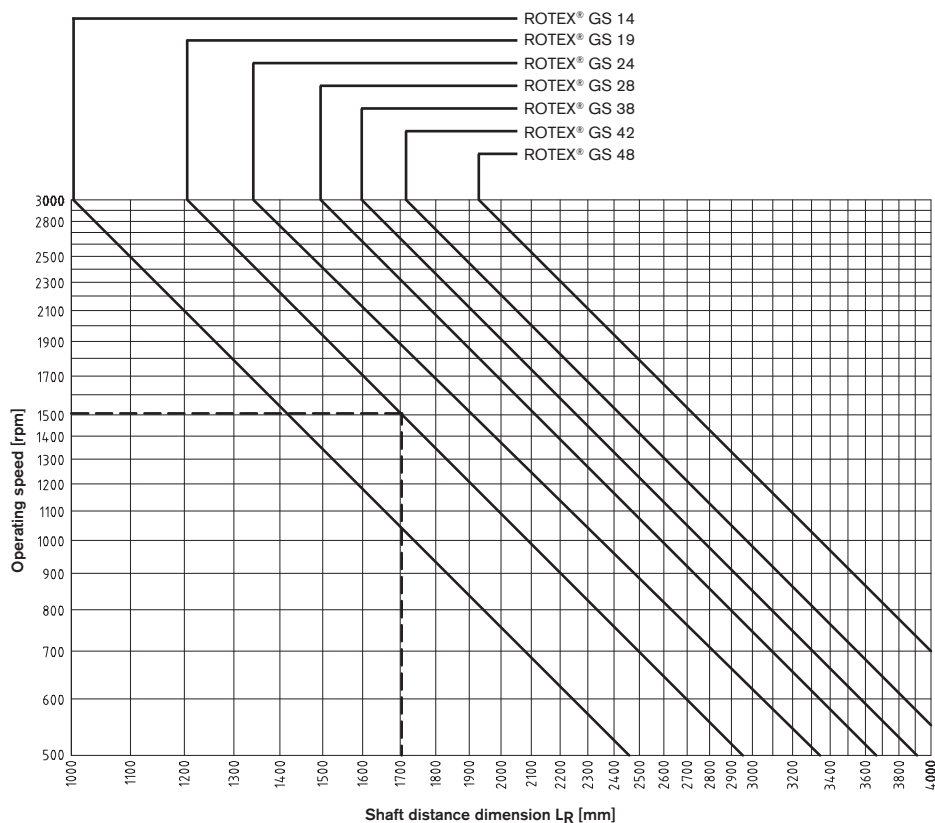

Example:
 ROTEX® GS 19
 Operating speed: 1500 rpm
 Max. perm. shaft distance dimension: 1700 mm
 Operating speed = $n_{crit}/1.4$

RADEX®-NC

COUNTEX®

ROTEX® GS

Backlash-free jaw couplings

Types of hubs

Due to the numerous applications of ROTEX® GS for many different mounting situations, this coupling system is available with various hub types. The different hub types can be combined optionally within one size.



Type 1.0
with feather keyway and setscrew
Positive-locking power transmission, permissible torque depending on the permissible surface pressure. Not suitable for backlash-free power transmission with heavily reversing operation.

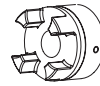

Type 1.1
without feather keyway, with setscrew
Non-positive torque transmission. Suitable for backlash-free transmission of very small torques.
(For ATEX category 3 only)

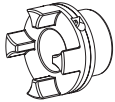

Type 1.5
with hydraulic clamping system
Integrated frictionally engaged shaft-hub-connection for transmitting high torques with easy assembly by means of a screw.



Type 2.0 clamping hub
single slot without feather keyway
Frictionally engaged, backlash-free shaft-hub-connection. Transmittable torques depending on bore diameter. Type 2.0 up to size 14 as standard.
(For ATEX category 3 only)



Type 2.1 clamping hub
single slot with feather keyway
Positive-locking power transmission with additional friction fit. The friction fit avoids or reduces reverse backlash. Surface pressure of the keyway connection is reduced. Type 2.1 up to size 14 as standard.



Type 2.5 clamping hub
double slotted, without feather keyway
Frictionally engaged, backlash-free shaft-hub-connection. Transmittable torques depending on bore diameter. Type 2.5 from size 19 as standard.
(For ATEX category 3 only)



Type 2.6 clamping hub
double slotted, with feather keyway
Positive-locking power transmission with additional friction fit. The friction fit avoids or reduces reverse backlash. Surface pressure of the keyway connection is reduced. Type 2.6 from size 19 as standard.

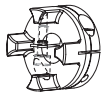

Type 2.8 short-type clamping hub C
with axial slot, without feather keyway
Frictionally engaged, backlash-free shaft-hub-connection, good properties of concentric running. Transmittable torques depending on bore diameter. Type 2.8 from size 24 as standard; size 7 - 19 type 2.8 single slotted.
(For ATEX category 3 only)

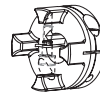

Type 2.8 short-type clamping hub C
with axial slot, with feather keyway
Positive-locking power transmission with additional friction fit. Surface pressure of the keyway connection is reduced. Type 2.9 from size 24 as standard; size 7 - 19 type 2.9 single slotted.



Type 6.0 clamping ring hub
Integrated frictionally engaged shaft-hub-connection for the transmission of higher torques. Screwing on elastomer side. For details about torque and dimensions see page 134/135 and HP page 138. Suitable for high speeds.



Type 6.0 precision clamping ring hub
Type 6.0 high-precision clamping ring hub
Operating principle equal to type 6.0, but highly accurate machining with slight modifications of design. See page 136/138.



Type 7.5 clamping hub type DH
without feather keyway for double-cardanic connections
Frictionally engaged, backlash-free shaft-hub-connection for radial assembly of coupling. Transmittable torques depending on bore diameter. For torques see page 146.



Type 7.6 clamping hub type DH
with feather keyway for double-cardanic connections
Positive shaft-hub-connection with additional friction fit for radial assembly of coupling. The friction fit avoids or reduces reverse backlash. Surface pressure of the keyway connection is reduced.



Type 7.8 clamping hub type H
without feather keyway for single-cardanic connection



Type 7.9 clamping hub type H
with feather keyway for single-cardanic connection

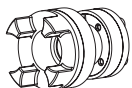

Type 4.2 with CLAMPEX KTR 250
Frictionally engaged shaft-hub-connection to transmit high torques with clamping screws externally.

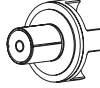

Type 9.0 expansion hub
Frictionally engaged connection for hollow shaft. Transmittable torques depend on bore diameter and hollow shaft.

Special designs on request of customers

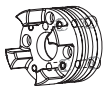

Type 6.5 clamping ring hub
Design equal to 6.0, but only clamping screws externally. As an example for radial disassembly of intermediate pipe (special design).

ROTEX® GS

Backlash-free jaw couplings

Stock programme

		Finish bore [mm] according to ISO fit H7 / feather keyway with thread according to DIN 6885 sheet 1 - JS9																															
Size	Hub design	un/pilot bored	Ø2	Ø3	Ø4	Ø5	Ø6	Ø 6.35	Ø7	Ø8	Ø9	Ø9.5	Ø10	Ø11	Ø12	Ø14	Ø15	Ø16	Ø18	Ø19	Ø20	Ø22	Ø24	Ø25	Ø28	Ø30	Ø32	Ø35	Ø38	Ø40	Ø42	Ø45	
7	1.1	●			●	●	●																										
	2.0	●		●	●	●	●	●	●																								
	2.8	●		●	●	●	●																										
8	2.8	●		●	●	●	●		●	●																							
	1.0	●					●			●	●			●																			
	1.1	●					●			●	●			●																			
9	2.0	●		●	●	●	●	●	●	●	●	●	●	●	●																		
	2.1	●					●			●	●			●																			
	2.8	●					●			●	●			●																			
12	1.0	●													●																		
	2.0	●			●	●	●	●		●	●			●	●	●																	
	2.1	●												●		●																	
13	2.8	●					●			●	●			●	●	●																	
	1.0	●					●			●	●			●	●	●	●	●	●	●	●	●	●	●	●	●	●	●	●	●	●	●	●
	1.1	●					●			●	●			●	●	●	●	●	●	●	●	●	●	●	●	●	●	●	●	●	●	●	●
14	2.0	●			●	●	●	●	●	●	●	●	●	●	●	●	●	●	●	●	●	●	●	●	●	●	●	●	●	●	●	●	●
	2.1	●																															
	2.8	●																															
16	6.0 light						●																										
	6.0 P																																
	2.8	●																															
19	1.0	●																															
	2.5	●					■																										
	2.6	●																															
24	2.8	●																															
	6.0 light																																
	6.0 steel																																
28	6.0 P 50																																
	6.0 P																																
	1.0	●																															
38	2.5	●																															
	2.6	●																															
	2.8	●																															
42	6.0 light																																
	6.0 steel																																
	6.0 light																																
48	6.0 steel																																
	6.0 steel																																
	6.0 steel																																
55	6.0 steel																																
	6.0 steel																																
	6.0 steel																																
75	6.0 steel																																
	6.0 steel																																
	6.0 steel																																
90	6.0 steel																																
	6.0 steel																																

Taper bores for Fanuc motors:
 GS 19 1:10 Ø11
 GS 24 1:10 Ø16
¹⁾ Type 2.0/2.1

		Finish bores [mm]														
Size	Hub design	Ø28	Ø30	Ø32	Ø35	Ø38	Ø40	Ø42	Ø45	Ø48	Ø50	Ø55	Ø60	Ø65	Ø70	Ø80
42	6.0 light	●		●	●	●		●	●		●					
	6.0 steel	●	●	●	●	●	●	●	●	●	●					
48	6.0 light			●	●	●	●	●	●	●	●					
	6.0 steel			●	●	●	●	●	●	●	●	●				
55	6.0 steel					●	●	●	●	●	●	●	●			
65	6.0 steel						●	●	●	●	●	●	●	●	●	
75	6.0 steel							●	●	●	●	●	●	●	●	●
90	6.0 steel															

■ = Pilot bored clamping hubs
 ● = Standard bore from stock
 Unbored hubs up to size 65 available from stock
 Other dimensions on request

ROTEX® GS

Backlash-free jaw couplings

Standard types



For legend of pictogram please refer to flapper on the cover

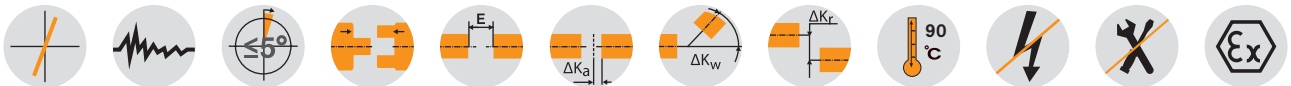

ROTEX® GS 5 - 38

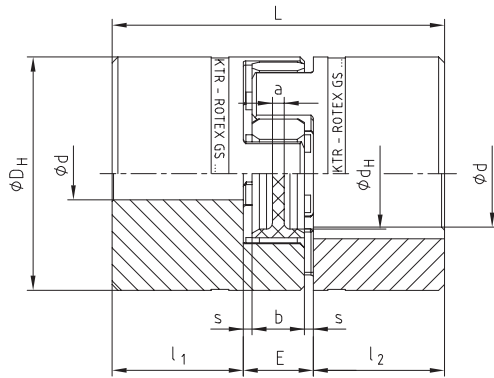

ROTEX® GS 42 - 90

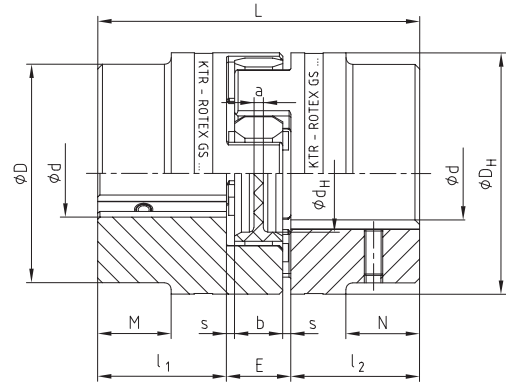

Types of hubs:

Type 1.0

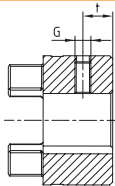

with feather keyway and setscrew

Type 1.1

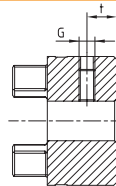

without feather keyway, with setscrew

Type 1.2

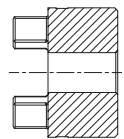

without feather keyway and without setscrew

ROTEX® GS standard types - For size 5 to 38 hub material aluminium/for size 42 to 90 hub material steel

Size	Spider GS ¹⁾ torque T _{KN} [Nm] for 98 ShA	d _{max.} for hub design			Dimensions [mm]										Setscrew DIN EN ISO 4029		
		1.0	1.1	1.2	D	D _H	d _H	L	l ₁ , l ₂	M, N	E	b	s	a	G	t	T _A
5	0.9	-	6	5	-	10	-	15	5	-	5	4	0.5	4.0	M2	2.5	0.35
7	2.0	7	7	7	-	14	-	22	7	-	8	6	1.0	6.0	M3	3.5	0.6
9	5.0	10	11	11	-	20	7.2	30	10	-	10	8	1.0	1.5	M4	5.0	1.5
12	9.0	12	12	12	-	25	8.5	34	11	-	12	10	1.0	3.5	M4	5.0	1.5
14	12.5	16	16	16	-	30	10.5	35	11	-	13	10	1.5	2.0	M4	5.0	1.5
19	21	24	-	-	-	40	18	66	25	-	16	12	2.0	3.0	M5	10	2.0
24	60	28	-	-	-	55	27	78	30	-	18	14	2.0	3.0	M5	10	2.0
28	160	38	-	-	-	65	30	90	35	-	20	15	2.5	4.0	M8	15	10
38	325	45	-	-	-	80	38	114	45	-	24	18	3.0	4.0	M8	15	10
42	450	55	-	-	85	95	46	126	50	28	26	20	3.0	4.0	M8	20	10
48	525	62	-	-	95	105	51	140	56	32	28	21	3.5	4.0	M8	20	10
55	685	74	-	-	110	120	60	160	65	37	30	22	4.0	4.5	M10	20	17
65	940	80	-	-	115	135	68	185	75	47	35	26	4.5	4.5	M10	20	17
75	1920	95	-	-	135	160	80	210	85	53	40	30	5.0	5.0	M10	25	17
90	3600	110	-	-	160	200	104	245	100	62	45	34	5.5	6.5	M12	30	40

¹⁾ For selections see page 22 et seqq/other spiders see page 123 and following

Ordering example:	ROTEX® GS 24	98 ShA-GS	d 20	2.5 - Ø24		1.0 - Ø20	
	Coupling size	Spider hardness	Optional: Bore in spider	Hub design	Finish bore	Hub design	Finish bore

Types of hubs:

Type 2.0
Type 2.1

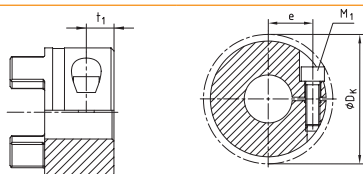

Size 5 to 14
Type 2.0: single slotted clamping hub **without** feather keyway (only for ATEX cat. 3), torque depending on bore Ø
Type 2.1: single slotted clamping hub **with** feather keyway

Type 2.5
Type 2.6

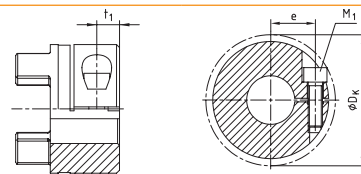

from size 19
Type 2.5: double slotted clamping hub **without** feather keyway (only for ATEX cat. 3), torque depending on bore Ø
Type 2.6: double slotted clamping hub **with** feather keyway

ROTEX® GS standard types - For size 5 to 38 hub material aluminium/for size 42 to 90 hub material steel

Size	Spider GS ¹⁾ torque T _{KN} [Nm] for 98 ShA	d _{max.} for hub design				Dimensions [mm]													Clamping screw DIN EN ISO 4762 (ROTEX® 5 - DIN EN ISO 1207)				
		2.0	2.1	2.5	2.6	D	D _H	d _H	L	l ₁ , l ₂	M, N	E	b	s	a	M ₁	t ₁	e	D _K	T _A [Nm]			
5	0.9	5	-	-	-	-	10	-	15	5	-	5	4	0.5	4.0	M1.2	2.5	3.5	11.4	- ²⁾			
7	2.0	7	7	-	-	-	14	-	22	7	-	8	6	1.0	6.0	M2	3.5	5.0	16.5	0.37			
9	5.0	11	11	-	-	-	20	7.2	30	10	-	10	8	1.0	1.5	M2.5	5.0	7.5	23.4	0.76			
12	9.0	12	12	-	-	-	25	8.5	34	11	-	12	10	1.0	3.5	M3	5.0	9.0	27.5	1.34			
14	12.5	16	16	-	-	-	30	10.5	35	11	-	13	10	1.5	2.0	M3	5.0	11.5	32.2	1.34			
19	21	-	-	24	24	-	40	18	66	25	-	16	12	2.0	3.0	M6	11.0	14.5	46	10.5			
24	60	-	-	28	28	-	55	27	78	30	-	18	14	2.0	3.0	M6	10.5	20.0	57.5	10.5			
28	160	-	-	38	38	-	65	30	90	35	-	20	15	2.5	4.0	M8	11.5	25.0	73	25			
38	325	-	-	45	45	-	80	38	114	45	-	24	18	3.0	4.0	M8	15.5	30.0	83.5	25			
42	450	-	-	50	45	85	95	46	126	50	28	26	20	3.0	4.0	M10	18	32.0	93.5	69			
48	525	-	-	55	55	95	105	51	140	56	32	28	21	3.5	4.0	M12	21	36.0	105	120			
55	685	-	-	68	68 ³⁾	110	120	60	160	65	37	30	22	4.0	4.5	M12	26	42.5	119.5	120			
65	940	-	-	70	70 ³⁾	115	135	68	185	75	47	35	26	4.5	4.5	M12	33	45.0	124	120			
75	1920	-	-	80	80	135	160	80	210	85	53	40	30	5.0	5.0	M16	36	51.0	147.5	295			
90	3600	-	-	90	90	160	200	104	245	100	62	45	34	5.5	6.5	M20	40	60.0	176	580			

¹⁾ For selections see page 22 et seq/other spiders see page 123 and following
²⁾ No T_A defined (slotted screw)
³⁾ From Ø60 keyway opposite the clamping screw

Review of shaft-hub-connection: Friction torques T_R [Nm] for hub design 2.0

Size	Ø2	Ø3	Ø4	Ø5	Ø6	Ø7	Ø8	Ø9	Ø10	Ø11	Ø12	Ø14	Ø15	Ø16
7		0.8	0.9	0.95	1.0	1.1								
9			2.1	2.2	2.3	2.4	2.5	2.6	2.7	2.8				
12			3.6	3.8	4.0	4.1	4.3	4.5	4.7	4.8	5.0			
14				4.7	4.8	5.0	5.1	5.3	5.5	5.6	5.8	6.1	6.3	6.5

Review of shaft-hub-connection: Friction torques T_R [Nm] for hub design 2.5

Size	Ø8	Ø10	Ø11	Ø14	Ø15	Ø16	Ø18	Ø19	Ø20	Ø22	Ø24	Ø25	Ø28	Ø30	Ø32	Ø35	Ø38	Ø40	Ø42	Ø45	Ø48	Ø50	Ø55	Ø60	Ø65	Ø70	Ø75	Ø80	Ø90
19	25	27	27	29	30	31	32	32	34	30 ⁴⁾	32 ⁴⁾																		
24		34	35	36	38	38	39	40	41	42	43	45	46																
28				80	81	81	84	85	87	89	91	92	97	99	102	105	109												
38					92	94	97	98	99	102	104	105	109	112	113	118	122	123	126	130									
42										232	238	244	246	255	260	266	274	283	288	294	301	309	315						
48												393	405	413	421	434	445	454	462	473	486	494	514						
55															473	486	498	507	514	526	539	547	567	587	608				
65																507	518	526	535	547	559	567	587	608	627	648			
75																		1102	1124	1148	1163	1201	1239	1278	1316	1354	1393		
90																			1944	1980	2016	2040	2100	2160	2220	2280	2340	2400	2520

⁴⁾ Clamping hub single slotted with 2-off clamping screws M4 and dimension e = 15

ROTEX® GS Compact

Backlash-free jaw couplings

Compact design



For legend of pictogram please refer to flapper on the cover

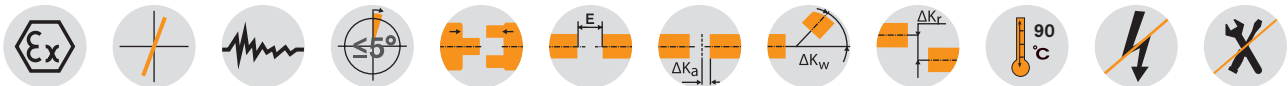

ROTEX® GS Compact																	
Size	Spider GS ¹⁾ torque T _{KN} [Nm]				Dimensions [mm]										Clamping screw DIN EN ISO 4762		
	80 ShA	92 ShA	98 ShA	64 ShD	d _{max.}	D _H	D _K	L	l ₁ , l ₂	E	b	s	d _H	t	e	M	T _A [Nm]
Single slotted hub design 2.8/2.9																	
7	0.7	1.2	2.0	2.4	7	14	16.6	18	5	8	6	1	-	2.5	5	M2	0.37
8	0.5	-	2.0	2.4	8	15	17.3	20	7	6	5	0.5	6.2	4	5.4	M2	0.52
9	1.8	3.0	5.0	6	9	20	21.3	24	7	10	8	1	-	3.5	6.7	M2.5	0.76
12	3.0	5.0	9.0	12	12	25	26.2	26	7	12	10	1	-	3.5	8.3	M3	1.34
13	3.6	-	11	14.5	12.7	25	25.7	26	8	10	8	1	10	4	8	M3	1.9
14	4.0	7.5	12.5	16	16 ²⁾	30	31.6	32	9.5	13	10	1.5	-	4.5	10	M4	2.9
16	5.0	-	15	19	16	30	32.5	32	10.3	11.4	9.4	1	14	5.3	10.5	M4	4.1
19	6.0	12.0	21.0	26.0	24 ²⁾	40	45.5	50	17	16	12	2	-	9	14.0	M6	10
Axially slotted hub design 2.8/2.9																	
24	-	35	60	75	32	55	57.5	54	18	18	14	2	-	11	20.0	M6	10
28	-	95	160	200	35	65	69.0	62	21	20	15	2.5	-	12	23.8	M8	25
38	-	190	325	405	45	80	86.0	76	26	24	18	3	-	15	29.5	M10	49

Review of shaft-hub-connection: Friction torques T _R [Nm] for hub design 2.8																										
Size	Ø3	Ø4	Ø5	Ø6	Ø7	Ø8	Ø9	Ø10	Ø11	Ø12	Ø14	Ø15	Ø16	Ø18	Ø19	Ø20	Ø24	Ø25	Ø28	Ø30	Ø32	Ø35	Ø38	Ø40	Ø42	Ø45
Single slotted hub design 2.8																										
7	0.8	0.9	1.0	1.0	1.1																					
8	0.65	0.85	1.1	1.3	1.5	1.7																				
9		1.9	2.0	2.1	2.2	2.3	2.4																			
12		3.4	3.6	3.7	3.9	4.1	4.2	4.4	4.6	4.7																
13		2.2	2.75	3.3	3.8	4.4	4.9	5.5	6	6.6																
14			7.1	7.4	7.7	8.0	8.2	8.5	8.8	9.1	5.8 ²⁾	5.9 ²⁾	6.1 ²⁾													
16			4.8	5.8	6.4	7.7	8.7	9.6	10.5	11.6	13.5	14.5	15.4													
19						24.3	25.0	25.7	26.3	27.0	28.4	29.0	29.7	31.1	31.7	32.4	25.0 ²⁾									
Axially slotted hub design 2.8																										
24								21	23	25	30	32	34	38	40	42	51	53	59	63	68					
28											54	58	62	70	74	78	93	97	109	116	124	136				
38											92	99	111	117	123	148	154	173	185	197	216	234	247	259	278	

¹⁾ For selections see page 22 et seqq/other spiders see page 123 and following

²⁾ Size 14 with screw M3 and dimension e = 10.4/D_K = 30.5/T_A = 1.35 Nm; size 19 with screw M5 and dimension e = 15.5/D_K = 47mm/T_A = 6 Nm

Ordering example:	ROTEX® GS 38	Compact	98 ShA-GS	d 28	2.8 - Ø28	2.8 - Ø45	
	Coupling size	Type	Spider hardness	Optional: Bore in spider	Hub design	Finish bore	Hub design

ROTEX® GS 8, 13, 16
Compact
single slotted type 2.8

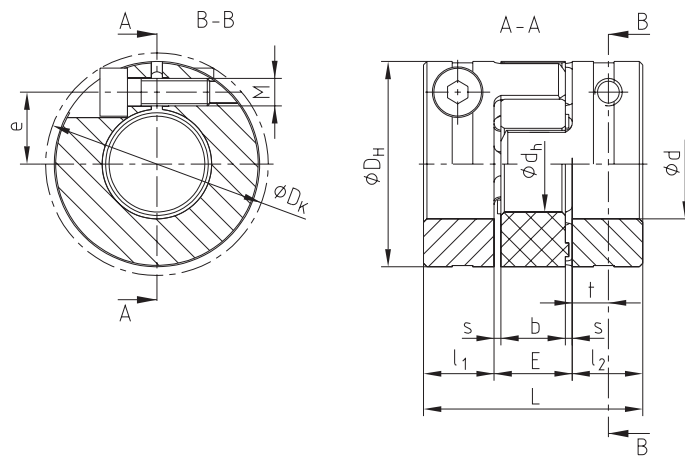

ROTEX® GS 7, 9, 12, 14, 19
Compact
single slotted type 2.8

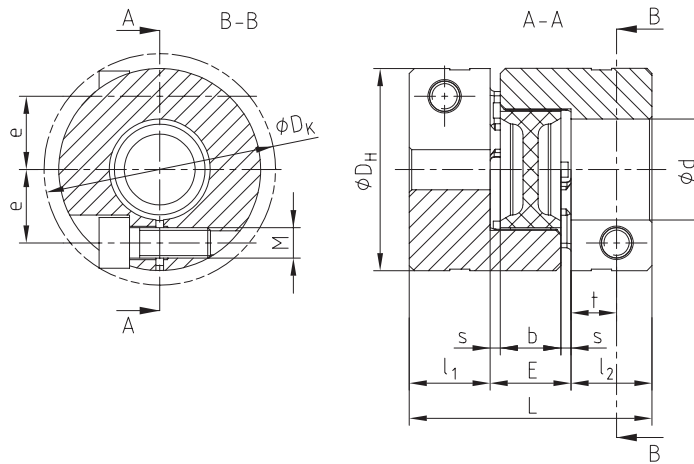

ROTEX® GS 24 - 38
Compact
axially slotted type 2.8

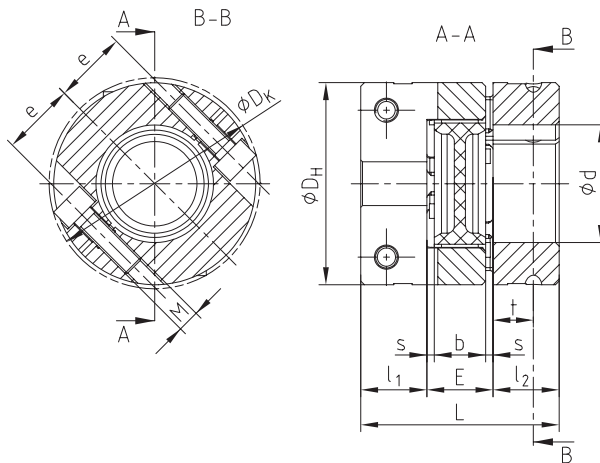

Types of hubs

Type 2.8

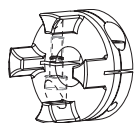

Short clamping hub C with axial slot, without feather keyway
Type 2.8 from size 24 as standard, size 7 - 19 type 2.8 single slotted

Type 2.9

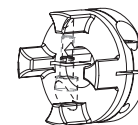

Short clamping hub C with axial slot, with feather keyway
Type 2.9 from size 24 as standard, size 7 - 19 type 2.9 single slotted

ROTEX® GS Clamping ring hubs light Backlash-free jaw couplings

Integrated clamping system made of aluminium

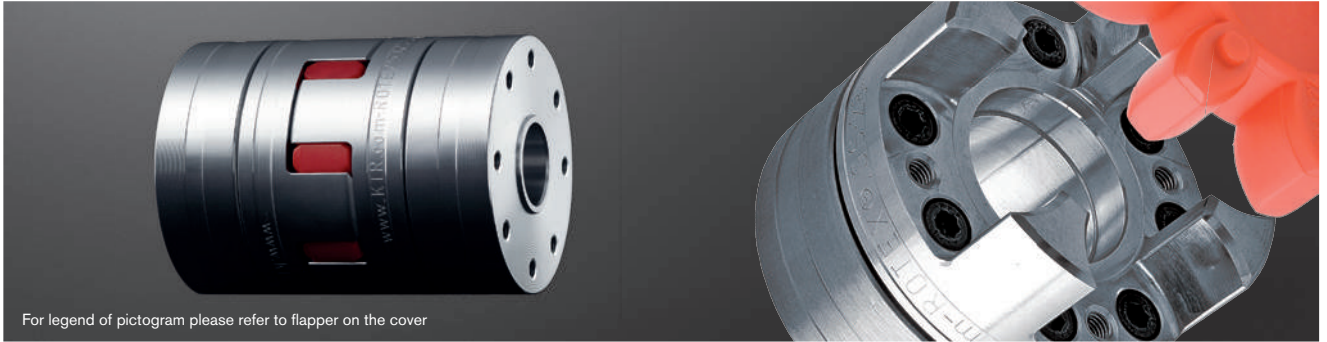

For legend of pictogram please refer to flapper on the cover



Tack thread M₁ between clamping screws

Clamping ring hub light with block mounting (hub and clamping ring mounted as a block)

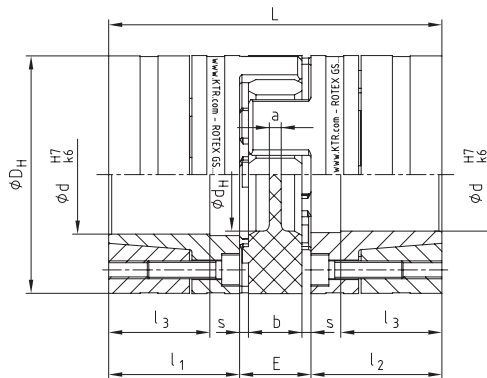

ROTEX® GS clamping ring hubs light

Size	Spider GS ¹⁾ torque T _{KN} [Nm]			Dimensions [mm]										Clamping screws DIN EN ISO 4762			Weight per hub with max. bore [kg]	Mass moment of inertia per hub with max. bore [kgm ²]	
	92 ShA	98 ShA	64 ShD	d _{max.}	D _H ²⁾	d _H	L	l _{1,2}	l ₃	E	b	s	a	M	z = number	T _A [Nm]			M ₁
14	7.5	12.5	16.0	14	30	10.5	50	18.5	13.5	13	10	1.5	2.0	M3	4	1.34	M3	0.032	0.04 x 10 ⁻⁴
19	12	21	26	20	40	18	66	25	18	16	12	2.0	3.0	M4	6	3	M4	0.077	0.19 x 10 ⁻⁴
24	35	60	75	32	55	27	78	30	22	18	14	2.0	3.0	M5	4	6	M5	0.162	0.78 x 10 ⁻⁴
28	95	160	200	38	65	30	90	35	27	20	15	2.5	4.0	M5	8	6	M5	0.240	1.70 x 10 ⁻⁴
38	190	325	405	48	80	38	114	45	35	24	18	3.0	4.0	M6	8	10	M6	0.490	5.17 x 10 ⁻⁴
42	265	450	560	51	95	46	126	50	35	26	20	3.0	4.0	M8	4	25	M8	0.772	11.17 x 10 ⁻⁴
48	310	525	655	55	105	51	140	56	41	28	21	3.5	4.0	M10	4	49	M10	1.066	18.81 x 10 ⁻⁴

¹⁾ For selections see page 22 et seqq/other spiders see page 123 and following

²⁾ ØD_H + 2 mm with high speeds for expansion of spider

Review of shaft-hub-connection: Friction torques T_R [Nm] for hub design 6.0 light

Size		Ø6	Ø8	Ø9	Ø10	Ø11	Ø14	Ø15	Ø16	Ø19	Ø20	Ø24	Ø25	Ø28	Ø30	Ø32	Ø35	Ø38	Ø40	Ø42	Ø45	Ø48	Ø50	Ø55*		
14	H7/k6	8.2	13.1	18.7	20.5	25.9	36.2																			
	H7/h6	5.8	9.5	15.7	16.6	21.6	24.7																			
19	H7/k6				33	41	59	71	51	80	92															
	H7/h6				27	35	52	65	39	68	81															
24	H7/k6						84	99	93	139	157	160	177	232												
	H7/h6						75	92	79	125	145	119	136	190												
28	H7/k6							140	207	188	289	316	355	414	324	404	422									
	H7/h6							121	187	157	263	293	318	381	245	324	343									
38	H7/k6									290	439	480	567	656	617	759	733		825	922	808	937				
	H7/h6									247	403	447	530	626	499	636	606	696	792	678	809					
42	H7/k6													651	752	747	916	1001	1115	1044	1218	1404	1432			
	H7/h6													574	681	613	774	881	1001	888	1058	1241	1295			
48	H7/k6													765	822	927	1121	1220	1357	1318	1536	1768	1535	1834		
	H7/h6													678	760	837	1047	1085	1231	1128	1339	1566	1331	1591		

* Standard bore tolerance H7, special tolerances on request * From Ø55 tolerance G7/m6

The torque is reduced with bigger fitting tolerances. Steel or nodular iron with a yield strength of approx. 250 N/mm² or more can be used as shaft material. For strength calculation of shaft/hollow shaft see KTR standard 45510 on our homepage www.ktr.com.

Ordering example:	ROTEX® GS 24	98 ShA-GS	d 20	6.0 light - Ø24		6.0 light - Ø20	
		Coupling size	Spider hardness	Optional: Bore in spider	Hub design	Finish bore	Hub design

ROTEX® GS Clamping ring hubs made of steel

Backlash-free jaw couplings

Integrated clamping system made of steel

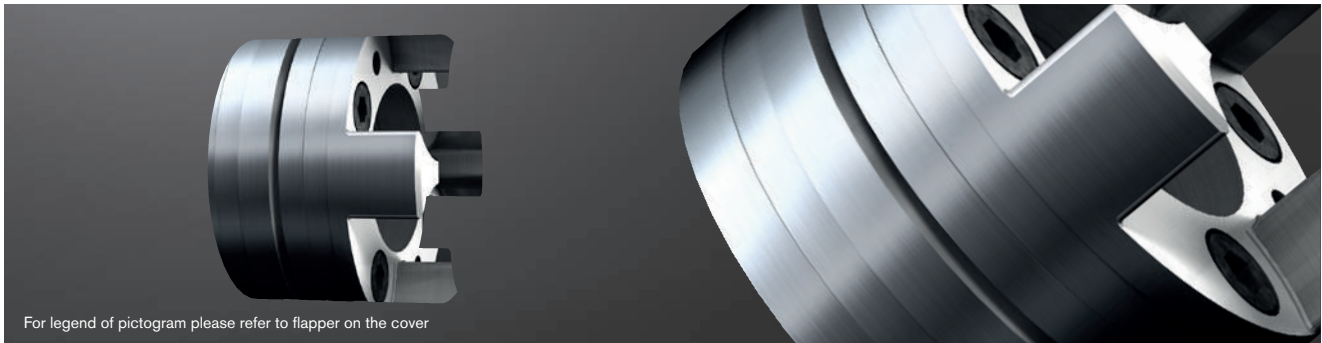

For legend of pictogram please refer to flapper on the cover

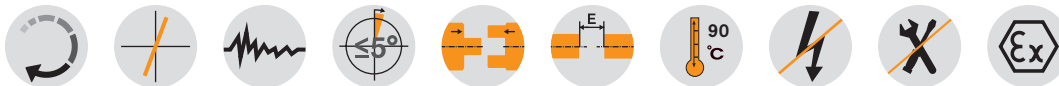

Tack thread M₁ between clamping screws

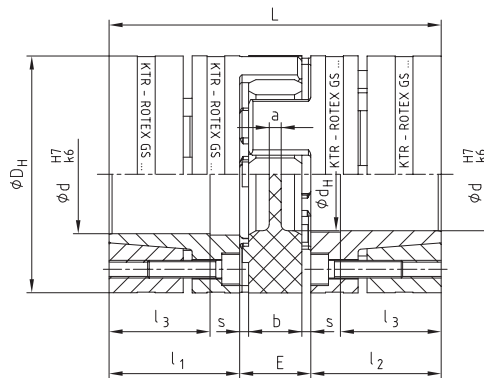

ROTEX® GS clamping ring hubs steel

Size	Spider GS ¹⁾ torque T _{KN} [Nm]			Dimensions [mm]										Clamping screws DIN EN ISO 4762			Weight per hub with max. bore [kg]	Mass moment of inertia per hub with max. bore [kgm ²]
	98 ShA	64 ShD	72 ShD	d _{max.}	D _H ²⁾	d _H	L	l ₁ , l ₂	l ₃	E	b	s	a	M	z = number	T _A [Nm]		
19	21	26	—	20	40	18	66	25 18	16	12	2.0	3.0	M4	6	4.1	M4	0.179	0.44 x 10 ⁻⁴
24	60	75	97	28	55	27	78	30 22	18	14	2.0	3.0	M5	4	8.5	M5	0.399	1.91 x 10 ⁻⁴
28	160	200	260	38	65	30	90	35 27	20	15	2.5	4.0	M5	8	8.5	M5	0.592	4.18 x 10 ⁻⁴
38	325	405	525	48	80	38	114	45 35	24	18	3.0	4.0	M6	8	14	M6	1.225	12.9 x 10 ⁻⁴
42	450	560	728	51	95	46	126	50 35	26	20	3.0	4.0	M8	4	41	M8	2.30	31.7 x 10 ⁻⁴
48	525	655	852	55	105	51	140	56 41	28	21	3.5	4.0	M10	4	69	M10	3.08	52.0 x 10 ⁻⁴
55	685	825	1072	70	120	60	160	65 45	30	22	4.0	4.5	M10	4	69	M10	4.67	103.0 x 10 ⁻⁴
65	940	1175	1527	70	135	68	185	75 55	35	26	4.5	4.5	M12	4	120	M12	6.70	191.0 x 10 ⁻⁴
75	1920	2400	—	80	160	80	210	85 63	40	30	5.0	5.0	M12	5	120	M12	9.90	396.8 x 10 ⁻⁴
90	3600	4500	—	105	200	104	245	100 75	45	34	5.5	6.5	M16	5	295	M16	17.7	1136 x 10 ⁻⁴

¹⁾ For selections see page 22 et seqq/other spiders see page 123 and following

²⁾ ØD_H + 2 mm with high speeds for expansion of spider

Review of shaft-hub-connection: Friction torques T_R [Nm] for hub design 6.0 steel

Size		Ø10	Ø11	Ø14	Ø15	Ø16	Ø19	Ø20	Ø24	Ø25	Ø28	Ø30	Ø32	Ø35	Ø38	Ø40	Ø42	Ø45	Ø48	Ø50	Ø55*	Ø60*	Ø65*	Ø70*	Ø80*	Ø90*	Ø95*	Ø100*	Ø105*
19	H7/k6	27	32	69	84	57	94	110																					
	H7/h6	15	18	57	74	38	76	94																					
24	H7/k6			70	87	56	97	114	116	133	192																		
	H7/h6			55	74	32	72	93	84	103	173																		
28	H7/k6			108	131	207	148	253	285	315	382	330	433	503															
	H7/h6			74	97	172	94	207	242	267	343	260	377	453															
38	H7/k6							208	353	395	439	531	463	603	593	689	793	776											
	H7/h6							136	290	337	373	476	367	525	491	601	721	677											
42	H7/k6								445	495	595	526	678	671	775	718	872	1043	1061										
	H7/h6								387	429	540	429	600	569	687	599	773	970	978										
48	H7/k6									616	704	899	896	1030	962	1160	1379	1222	1543										
	H7/h6									513	590	806	775	924	822	1042	1290	1073	—										
55	H7/k6												863	856	991	918	1119	1110	1247	1277	1665	1605	2008						
	H7/h6												750	710	863	750	976	934	1089	—	—	—	—						
65	H7/k6														1446	1355	1637	1635	1827	1887	2429	2368	2930						
	H7/h6														1275	1135	1447	1404	1619	—	—	—	—						
75	H7/k6															1710	2053	2059	2294	2384	3040	2983	3664	4293					
	H7/h6															1460	1836	1797	2056	—	—	—	—						
90	H7/k6																			3845	4249	4794	5858	5900	7036	8047	9247	9575	10845
	H7/h6																			3445	—	—	—	—	—	—	—	—	—

* From Ø55 tolerance G7/m6

The torque is reduced with bigger fitting tolerances. For the strength calculation of shaft/hollow shaft see KTR standard 45510 on our homepage www.ktr.com.

Ordering example:	ROTEX® GS 24	98 ShA-GS	d 20	6.0 steel - Ø24		6.0 steel - Ø20	
	Coupling size	Spider hardness	Optional: Bore in spider	Hub design	Finish bore	Hub design	Finish bore

ROTEX® GS P

Backlash-free jaw couplings

Highly accurate type P according to DIN 69002



For legend of pictogram please refer to flapper on the cover

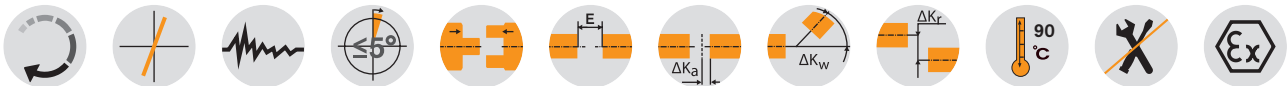

ROTEX® GS P - hubs/clamping ring material steel																	
Size	Spider GS ¹⁾ torque T _{KN} [Nm]		Dimensions [mm]											Tightening torque of clamping screws T _A [Nm]	Weight per hub with bore d standard [kg]	Mass moment of inertia with bore d standard [kgm ²]	
	98 ShA	64 ShD	d _{max.}	D _H ²⁾	d _H	L	l ₁ , l ₂	l	E	b	s	a	d ₃				
14 P	12.5	16	15	32	10.5	50	18.5	15.5	13	10	1.5	2	—	1.89	0.08	0.011 x 10 ⁻³	
19 P	21	26	20	40	18	66	25	21	16	12	2	3	—	3.05	0.19	0.046 x 10 ⁻³	
24 P	60	75	28	55	27	78	30	25	18	14	2	3	—	8.5	0.44	0.201 x 10 ⁻³	
28 P	160	200	38	65	30	90	35	30	20	15	2.5	4	—	8.5	0.64	0.438 x 10 ⁻³	
38 P	325	405	48	80	38	114	45	40	24	18	3	4	—	14	1.32	1.325 x 10 ⁻³	
42 P	450	560	51	95	46	126	50	45	26	20	3	4	18.5	35	2.23	3.003 x 10 ⁻³	
48 P	525	655	55	105	51	140	56	50	28	21	3.5	4	20.5	69	3.09	5.043 x 10 ⁻³	
55 P	685	825	70	120	60	160	65	58	30	22	4	4.5	22.5	69	4.74	10.02 x 10 ⁻³	
65 P	940	1175	70	135	68	185	75	55	35	26	4.5	4.5	30	120	6.70	191.0 x 10 ⁻⁴	
75 P	1920	2400	80	160	80	210	85	63	40	30	5.0	5.0	40	120	9.90	396.8 x 10 ⁻⁴	
90 P	3600	4500	105	200	104	245	100	75	45	34	5.5	6.5	50	295	17.7	1136 x 10 ⁻⁴	

¹⁾ For selections see page 22 et seqq/other spiders see page 123 and following

²⁾ Ø D_H + 2 mm with high speeds for expansion of spider

For the strength calculation of shaft/hollow shaft see KTR standard 45610 on our homepage www.ktr.com.

Review of shaft-hub-connection: Friction torques T _R [Nm] for hub design 6.0 steel																														
Size		Ø10	Ø11	Ø14	Ø15	Ø16	Ø19	Ø20	Ø24	Ø25	Ø28	Ø30	Ø32	Ø35	Ø38	Ø40	Ø42	Ø45	Ø48	Ø50	Ø55	Ø60	Ø65	Ø70	Ø80	Ø90	Ø95	Ø100	Ø105*	
14	H6/k6	11	13	29																										
19	H6/k6	34	41	75	90	68	104	119																						
24	H6/k6			79	95	70	110	126	134	149	201																			
28	H6/k6				128	150	225	177	278	307	341	403	366	461	528															
38	H6/k6							247	386	426	475	560	511	641	644	733	828	825												
42	H6/k6								389	433		512	464	585	586	669	631	753	888	906										
48	H6/k6											672	762	945	957	1082	1033	1219	1423	1296	1606									
55	H6/k6													920	929	1055	1002	1190	1198	1325	1388	1743	1722	2088						
65	H6/k6															1532	1465	1731	1750	1931	2034	2534	2521	3038						
75	H6/k6																1835	2161	2190	2413	2551	3161	3158	3789	4421					
90	H6/k6																				4046	4503	5057	6079	6181	7324	8398	9530	9892	11084

* From Ø55 G6/m6.

The torque is reduced with bigger fitting tolerances. For the strength calculation of shaft/hollow shaft see KTR standard 45610 on our homepage www.ktr.com.

Assignment for stub spindles according to DIN 69002													
Spindle drive	ROTEX® GS P size	Dimensions according to DIN 69002									Transmittable torque T _R with d [Nm] ³⁾	Weight per hub with bore d standard ³⁾ [kg]	Mass moment of inertia with bore d standard ³⁾ [kgm ²]
		Standard spindle shaft diameter d	d ₁	d ₂	d ₃	D _H	l ₁ , l ₂	L	E				
25 x 20	14 P	14	17	17	8.5	32	18.5	50	13	25	0.08	0.011 x 10 ⁻³	
32k x 25	19 P37.5	16	20	19	9.5	37.5	25	66	16	60	0.16	0.037 x 10 ⁻³	
32g x 30	19 P	19	23	22	9.5	40	25	66	16	71	0.19	0.046 x 10 ⁻³	
40 x 35	24 P50	24	28	29	12.5	50	30	78	18	108	0.331	0.136 x 10 ⁻³	
50 x 45	24 P	25	30	30	12.5	55	30	78	18	170	0.44	0.201 x 10 ⁻³	
63 x 55	28 P	35	40	40	14.5	65	35	90	20	506	0.64	0.438 x 10 ⁻³	
80 x 75	38 P	40	46	46	16.5	80	45	114	24	821	1.32	1.325 x 10 ⁻³	

³⁾ Standard spindle shaft diameter

Ordering example:	ROTEX® GS P 24	98 ShA-GS	6.0 - Ø25		6.0 - Ø25	
	Coupling size	Spider hardness	Hub design	Finish bore	Hub design	Finish bore

Components

Tack thread M₁ between clamping screws

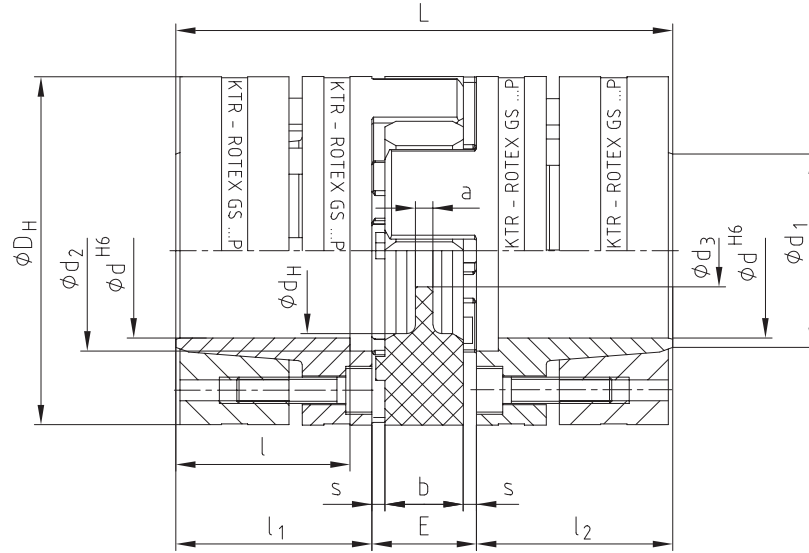

ROTEX® GS P with central coolant supply for stub spindles and multiple spindle heads

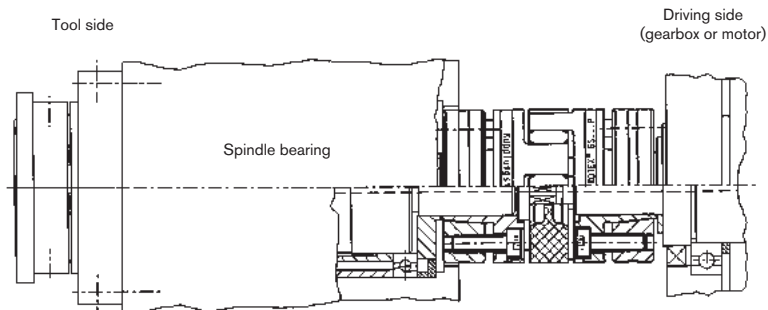

ROTEX® GS HP

Backlash-free shaft coupling

Highly accurate closed coupling system

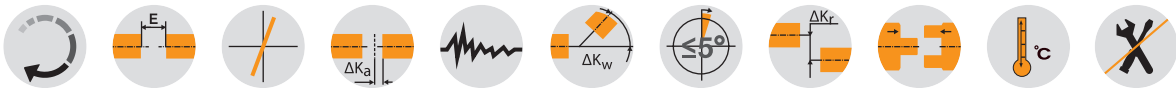
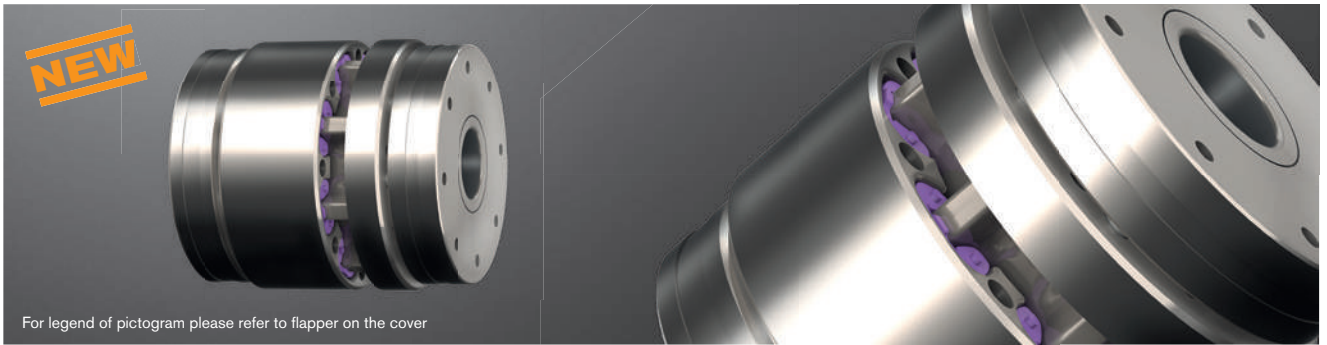

ROTEX® GS HP - clamping ring hubs/clamping ring material steel

Size	Spider GS ¹⁾ torque T _{KN} [Nm] for 98 ShA-GS/52 ShD-GS		Max. speed [rpm]	Dimensions [mm]											Clamping screws DIN EN ISO 4762			Weight per hub with max. bore [kg]	Mass moment of inertia of coupling with max. bore [kgm ²]
	T _{KN}	T _K max		Max. d ₁ , d ₂	DH	D	L	l ₁ , l ₂	l ₃ , l ₄	N	E	b	s	M	z = number	T _A [Nm]			
24	100	200	59,000	25	55	48	73	25	18	15	24	20	2	5	5	7.7	0.74	0.000317	
28	160	320	47,000	35	65	58	78	27	17	17	24	20	2	5	6	7.7	1.02	0.000653	
38	400	800	39,000	45	80	76	82	29	18	18	24	20	2	5	8	7.7	1.54	0.001534	
42	475	950	35,000	51	95	82	99	36	24	24	27	22	2.5	6	8	13	2.59	0.003441	
48	550	1100	30,000	55	105	92	101	37	25	25	27	22	2.5	6	9	13	3.39	0.005481	
55	725	1450	26,000	60	120	105	103	38	26	26	27	22	2.5	6	10	13	6.84	0.009172	

¹⁾ For selections see page 22 et seqq/other spiders see page 123 and following

Review of shaft-hub-connection: Friction torques T_R [Nm] for hub design 6.0 steel

Size		Ø12	Ø15	Ø18	Ø19	Ø20	Ø22	Ø25	Ø28	Ø32	Ø35	Ø38	Ø40	Ø42	Ø45	Ø48	Ø50	Ø55 *	Ø60 *
24	H6/k6	55	102	165	115	133	172	241											
28	H6/k6		125	199	226	158	202	280	246	340	432								
38	H6/k6					216	274	376	374	508	635	586	666	752	649				
42	H6/k6									665	830	1015	770	871	1035	1215	1153		
48	H6/k6													957	1135	1330	1132	1424	
55	H6/k6													1220	1440	1455	1604	1635	2026

* From Ø55 G6/m6.

The torque is reduced with bigger fitting tolerances. For the strength calculation of shaft/hollow shaft see KTR standard 45710 on our homepage www.ktr.com.

Displacements

Size	Spider GS	Displacements		
		Axial ΔK _a [mm]	Radial ΔK _r [mm]	Angular ΔK _w [degree]
24	98 ShA	+1.0/-0.8	0.10	0.9
28	98 ShA			
38	98 ShA			
42	52 ShD	+1.4/-1.0	0.14	
48	52 ShD			
55	52 ShD			

The displacement figures may only be used one by one, if they appear simultaneously, they must be limited in proportion. Care should be taken to maintain the distance dimension E accurately in order to allow for axial clearance of the coupling while in operation. Detailed mounting instructions are shown on our homepage www.ktr.com.

Ordering
example:

ROTEX® GS 24 HP	98 ShA-GS	6.0 - Ø25		6.0 - Ø25	
Coupling size	Spider hardness	Hub design	Finish bore	Hub design	Finish bore

Components

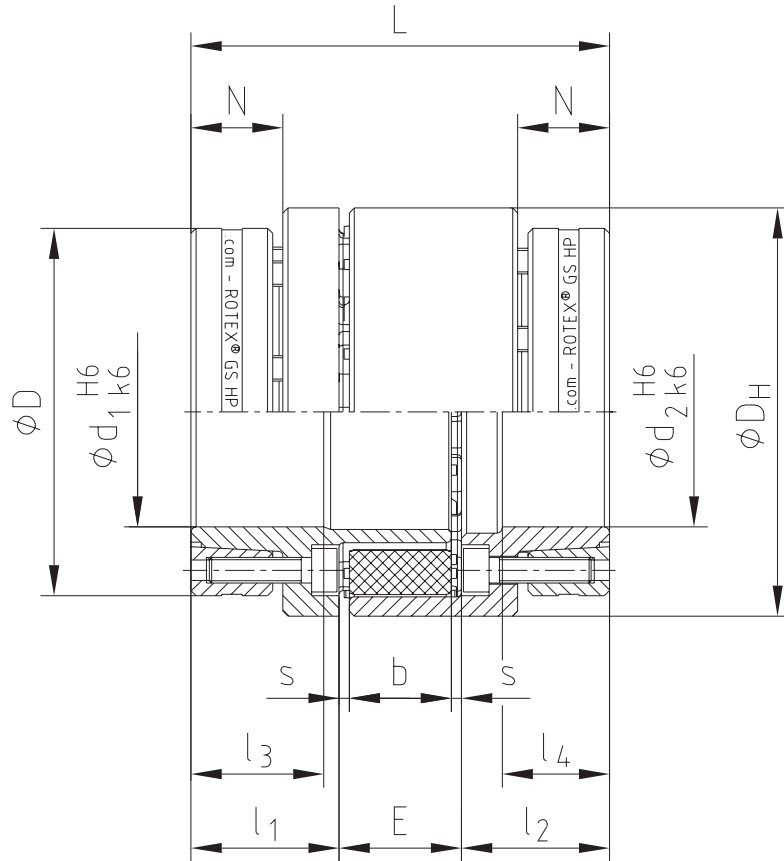

ROTEX® GS

TOOLFLEX®

RADEX®-NC

COUNTEX®

Backlash-free
servo couplings

ROTEX® GS P ETP®

Backlash-free jaw couplings

Integrated hydraulic clamping system

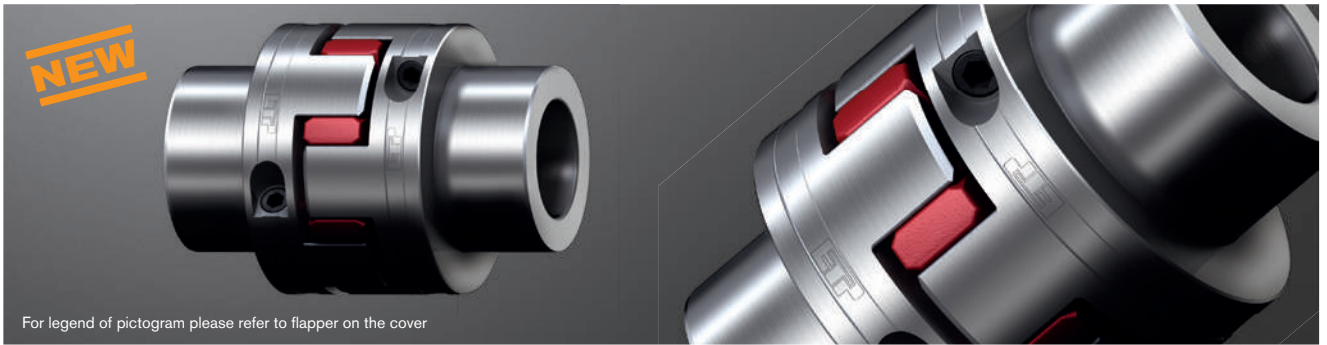

For legend of pictogram please refer to flapper on the cover

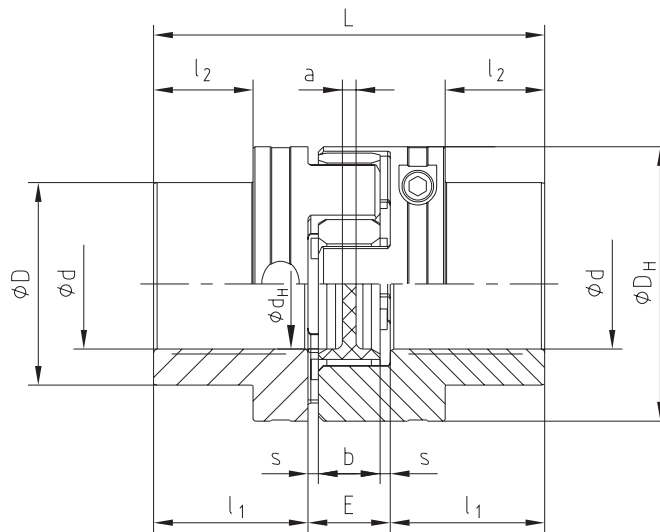
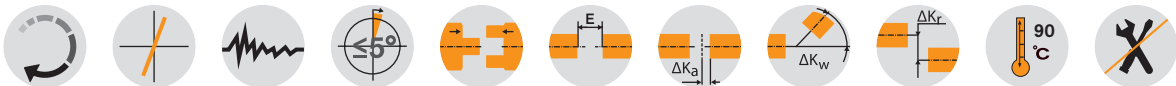

ROTEX® GS P ETP®																	
Size	Spider GS ¹⁾ torque T _{KN} [Nm]			Dimensions [mm]										Screw		Weight per hub with max. bore [kg]	
	92 ShA	98 ShA	64 ShD	dmax.	D _H ²⁾	d _H	L	l ₁	l ₂	E	b	s	a	M	T _A [Nm]		
24	35	60	75	24	55	27	78	30	16	18	14	2	3	M6	5	0.33	
28	95	160	200	32	65	30	90	35	20	20	15	2.5	4	M6	5	0.53	
38	190	325	405	40	80	38	114	45	29	24	18	3	4	M6	5	0.98	
42	265	450	560	48	95	46	126	50	34	26	20	3.5	4	M6	5	1.51	

¹⁾ For selections see page 22 et seqq/other spiders see page 123 and following

²⁾ ØD_H + 2 mm with high speeds for expansion of spider

Review of shaft-hub-connection: Friction torques T _R [Nm] for hub design ROTEX® GS P ETP®																	
Size	Toleran- ce fit	Bore diameter d/collar diameter D															
		Ø15/ Ø24	Ø16/ Ø26	Ø19/ Ø30	Ø20/ Ø32	Ø24/ Ø39	Ø25/ Ø40	Ø28/ Ø44	Ø30/ Ø47	Ø32/ Ø50	Ø35/ Ø55	Ø38/ Ø59	Ø40/ Ø62	Ø42/ Ø65	Ø45/ Ø70	Ø48/ Ø74	
24	F6/h6	42	50	70	80	125											
28		50	60	80	95	150	160	210	230	250							
38						220	230	310	350	380	450	570	610				
42							270	360	410	440	540	660	730	820	940	1100	

ETP® is a registered trademark by ETP® Transmission AB.

Ordering example:	ROTEX® GS P ETP® 24	98 ShA-GS	d 20	Ø24	Ø20
		Coupling size	Spider hardness	Optional: Bore in spider	Finish bore

ROTEX® GS expansion hubs

Backlash-free jaw couplings

Clamping system for hollow shaft connection

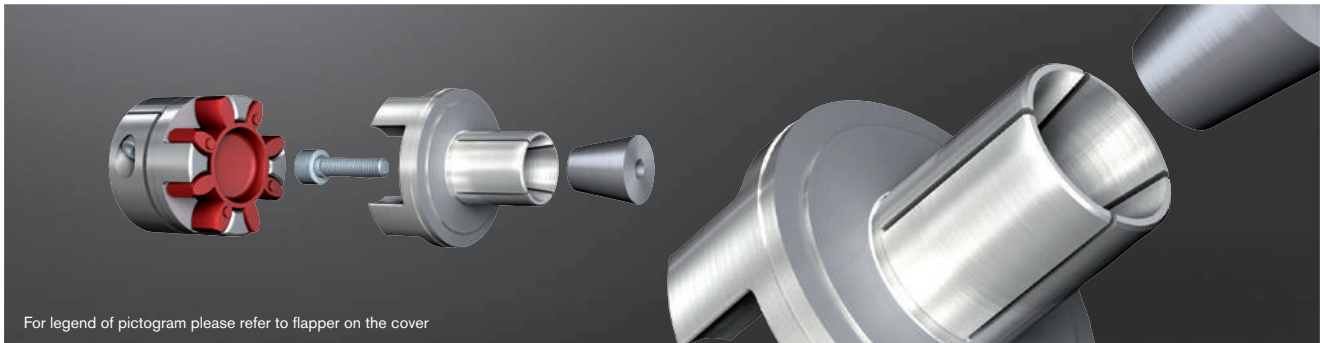

For legend of pictogram please refer to flapper on the cover

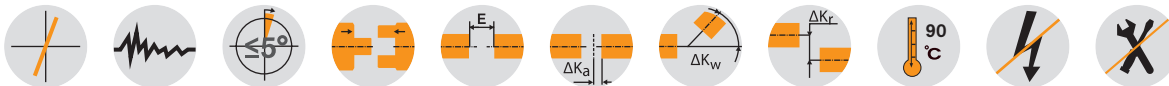

ROTEX® GS expansion hub - Expansion hub material aluminium/clamp pin material stainless steel

Size	Spider GS ²⁾ torque T _{KN} [Nm]					Dimensions [mm]											
	80 ShA	92 ShA	98 ShA	64 ShD	72 ShD	D ₁ ³⁾	D ₂	D _H	l ₁ ³⁾	l ₂ ¹⁾	l ₄ ³⁾	l ₅ ³⁾	l ₆	L ¹⁾	E	b	s
9	1.8	3.0	5.0	6.0	-	10	-	20	20	10	11	-	0	40	10	8	1.0
12	3.0	5.0	9.0	12.0	-	10	20	25	19	11	14	1.5	2	42	12	10	1.0
14	4.0	7.5	12.5	16.0	-	12	24	30	18.5	11	12.5	3	2	42.5	13	10	1.5
19	6.0	12.0	21.0	26.0	-	20	35	40	28	25	20	1	0	69	16	12	2.0
24	-	35	60	75	97	25	45	55	38	30	30	1	4	86	18	14	2.0
28	-	95	160	200	260	35	55	65	44	35	36	1	5	99	20	15	2.5

¹⁾ For selections see page 22 et seq/other spiders see page 123 and following

Review of shaft-hub-connection: Friction torques T_R [Nm] for hub design 9.0*

Size	D ₁ ³⁾	D ₂	l ₁ ³⁾	l ₄ ³⁾	l ₅ ³⁾	Friction torque [Nm]
9	10	-	20	11	-	6.4
12	10	20	19	14	1.5	7.7
14	12	24	18.5	12.5	3	7.7
19	20	35	28	20	1	35.7
24	25	45	38	30	1	82
28	35	55	44	36	1	182

²⁾ The expansion hub can be combined with other types of hubs to form the opposite side, too. l₂ depends on the hub design. For further types of hubs see page 128.

³⁾ Dimensions D₁, l₁, l₄ and l₅ are examples. Other dimensions on customers' request.

* The transmittable torques of the clamping connection consider the dimensions D₁, D₂, l₄ and l₅ as specified with steel being the material of the hollow shaft.

ROTEX® GS expansion hub type 9.0 with clamping hub¹⁾

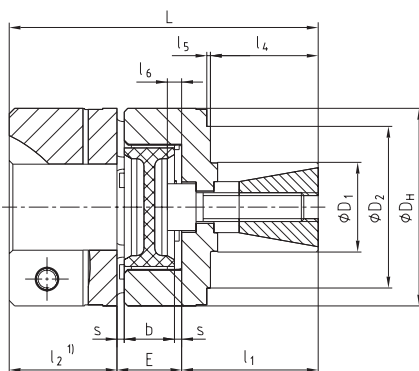

ROTEX® GS expansion hub for axis of belt

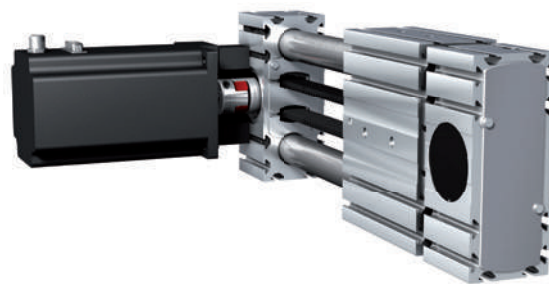

Special types for hollow shaft connections

Shaft extension

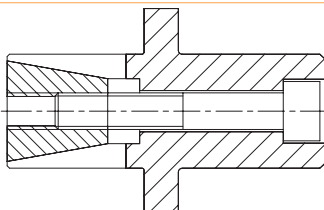

ROTEX® GS hub with CLAMPEX® KTR 150

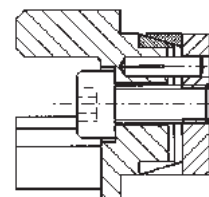

Ordering example:

ROTEX® GS 24	98 ShA-GS	d 20	9.0 - Ø24		2.5 - Ø20	
Coupling size	Spider hardness	Optional: Bore in spider	Hub design	Finish bore	Hub design	Finish bore

ROTEX® GS A-H

Backlash-free jaw couplings

Drop-out center design coupling

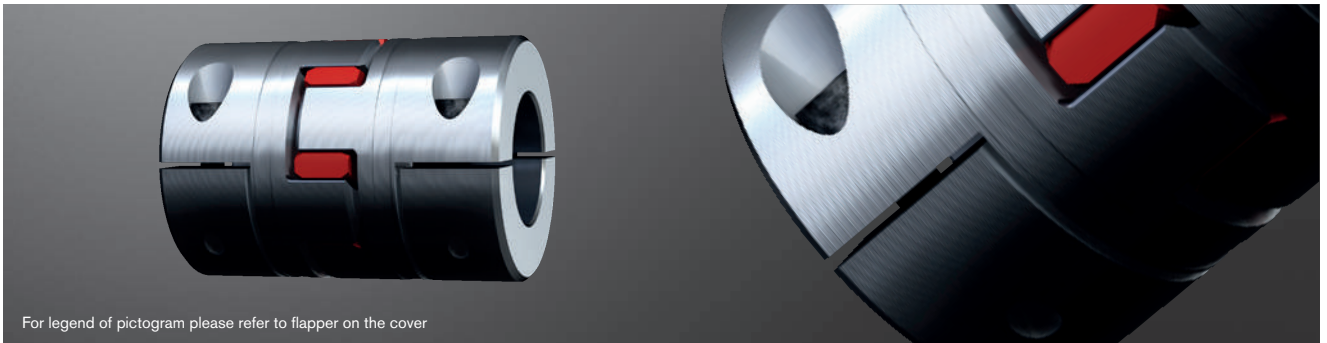

For legend of pictogram please refer to flapper on the cover

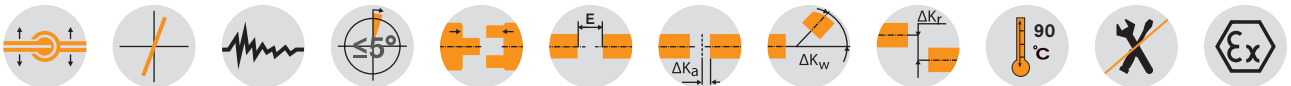

ROTEX® GS type A-H - Hub material aluminium

Size	Dimensions [mm]										Cap screws DIN EN ISO 4762	
	dmax.	L	l ₁ , l ₂	E	b	s	D _H	D _K	x ₁ , x ₂	E ₁	M	T _A [Nm]
19	20	66	25	16	12	2.0	40	46	17.5	31	M6	10
24	28	78	30	18	14	2.0	55	57.5	22.0	34	M6	10
28	38	90	35	20	15	2.5	65	73	25.0	40	M8	25
38	45	114	45	24	18	3.0	80	83.5	33.0	48	M8	25
42	50	126	50	26	20	3.0	95	93.5	39	48	M10	49

Technical data

Size	Spider Shore-GS ¹⁾	Shore scale	Max. speed [rpm]	Torque [Nm]		Static torsion spring stiffness [Nm/rad]	Weight per hub with max. bore [kg]	Mass moment of inertia J per hub with max. bore [kgm ²]
				T _{KN}	T _{K,max}			
19	80	A	9550	6.0	12.0	618	77 x 10 ⁻³	19.6 x 10 ⁻⁶
	92	A		12.0	24.0	1090		
	98	A		21.0	42.0	1512		
	64	D		26.0	52.0	2560		
24	92	A	6950	35	70	2280	161 x 10 ⁻³	77.3 x 10 ⁻⁶
	98	A		60	120	3640		
	64	D		75	150	5030		
28	92	A	5850	95	190	4080	240 x 10 ⁻³	173 x 10 ⁻⁶
	98	A		160	320	6410		
	64	D		200	400	10260		
38	92	A	4750	190	380	6525	470 x 10 ⁻³	496 x 10 ⁻⁶
	98	A		325	650	11800		
	64	D		405	810	26300		
42	92	A	4000	265	530	10870	1770 x 10 ⁻³	2409 x 10 ⁻⁶
	98	A		450	900	21594		
	64	D		560	1120	36860		

¹⁾ For selections see page 22 et seqq/other spiders see page 123 and following

²⁾ Static torsion spring stiffness with 0.5 x T_{KN}

To make sure that the coupling can be assembled/disassembled radially, observe the insertion dimension x₁/x₂ of the shafts.

Review of shaft-hub-connection: Friction torques T_R [Nm] for hub design 7.8

Size	Ø8	Ø10	Ø11	Ø14	Ø15	Ø16	Ø18	Ø19	Ø20	Ø22	Ø24	Ø25	Ø28	Ø30	Ø32	Ø35	Ø38	Ø40	Ø42	Ø45	Ø46	Ø48	Ø50
19	17	21	23	30	32	34	38	40	42														
24		21	23	30	32	34	38	40	42	47	51	53	59										
28				54	58	62	70	74	78	86	93	97	109	117	124	136	148						
38							70	74	78	86	93	97	109	117	124	136	148	156	163	175			
42										136	149	155	174	186	198	217	235	248	260	279	285	297	310

Ordering example:

ROTEX® GS 38	A-H	98 ShA-GS	7.8 – Ø38		7.9 – Ø30	
Coupling size	Type	Spider hardness	Hub design	Finish bore	Hub design	Finish bore

Type A-H

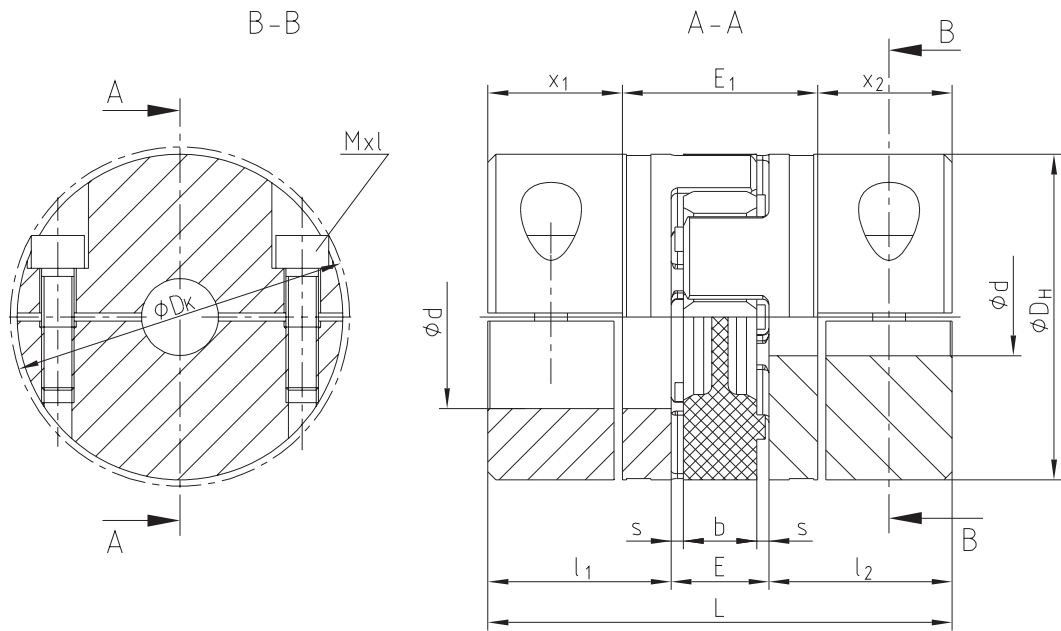

Caution:
The feather keyways are offset to each other by approx. 5°!
Hub material: Al-H

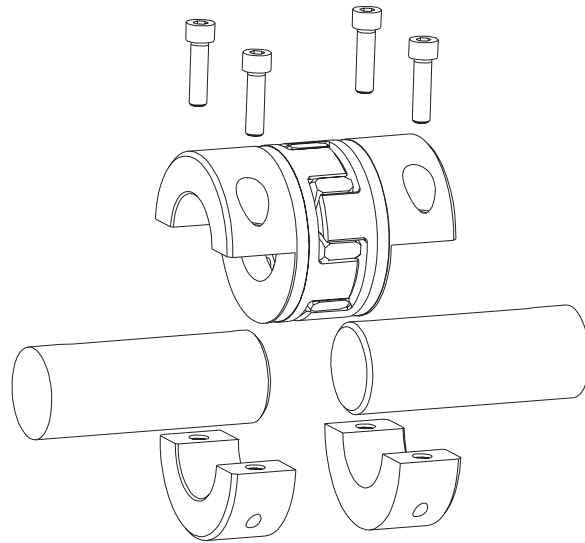

Types of hubs

Type 7.8

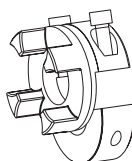

clamping hub type H without feather keyway for single-cardanic connection

Type 7.9

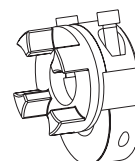

clamping hub type H with feather keyway for single-cardanic connection

ROTEX® GS DKM

Backlash-free jaw couplings

Double-cardanic jaw coupling

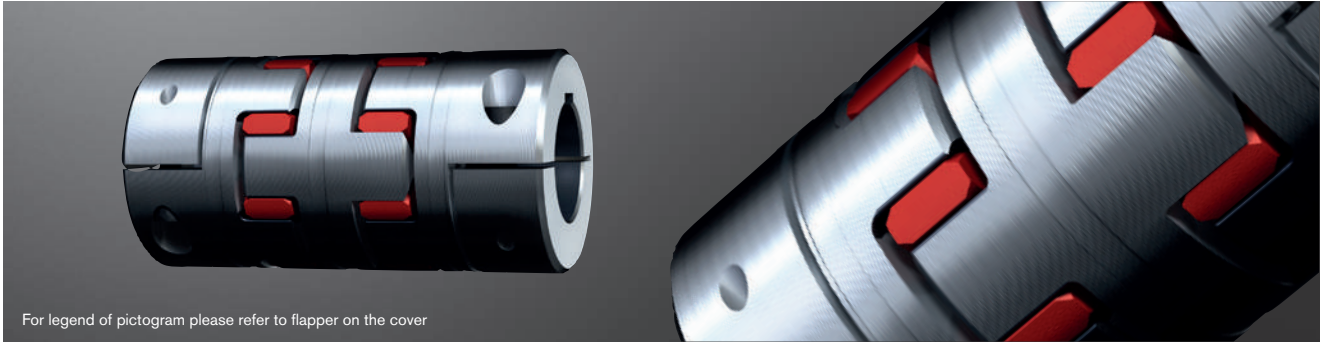

For legend of pictogram please refer to flapper on the cover

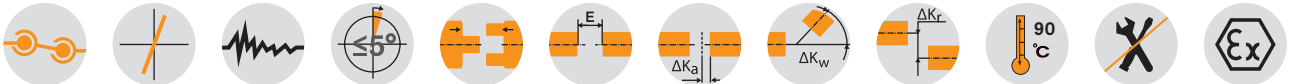

ROTEX® GS DKM - Spacer material aluminium/hub material depends on hub design

Size	Spider GS ¹⁾ torque T _{KN} [Nm]		Dimensions [mm]													
	98 ShA	64 ShD	d _{max.} ²⁾	D	D _H	d _H	d _{H1}	l ₁ , l ₂	M, N	l ₁₁	l ₁₂	LDKM	E	b	s	a
5	0.9	—	5	—	10	—	—	5	—	3	13	23	5	4	0.5	4.0
7	2.0	2.4	7	—	14	—	—	7	—	4	20	34	8	6	1.0	6.0
9	5.0	6.0	11	—	20	7.2	—	10	—	5	25	45	10	8	1.0	1.5
12	9.0	12.0	12	—	25	8.5	—	11	—	6	30	52	12	10	1.0	3.5
14	12.5	16.0	16	—	30	10.5	—	11	—	8	34	56	13	10	1.5	2.0
19	21.0	26.0	24	—	40	18.0	18	25	—	10	42	92	16	12	2.0	3.0
24	60	75	28	—	55	27.0	27	30	—	16	52	112	18	14	2.0	3.0
28	160	200	38	—	65	30.0	30	35	—	18	58	128	20	15	2.5	4.0
38	325	405	45	—	80	38.0	38	45	—	20	68	158	24	18	3.0	4.0
42	450	560	55	85	95	46	46	50	28	22	74	174	26	20	3.0	4.0
48	525	655	62	95	105	51	51	56	32	24	80	192	28	21	3.5	4.0
55	685	825	74	110	120	60	60	65	37	28	88	218	30	22	4.0	4.5

¹⁾ For selections see page 22 et seqq/other spiders see page 123 and following

²⁾ Dependent on type of hub. Hub types can be freely selected, for summary see page 124.

Ordering
example:

ROTEX® GS 24	DKM	98 ShA-GS	d 25	1.0 - Ø38		2.5 - Ø25	
Coupling size	Type	Spider hardness	Optional: Bore in spider	Hub design	Finish bore	Hub design	Finish bore

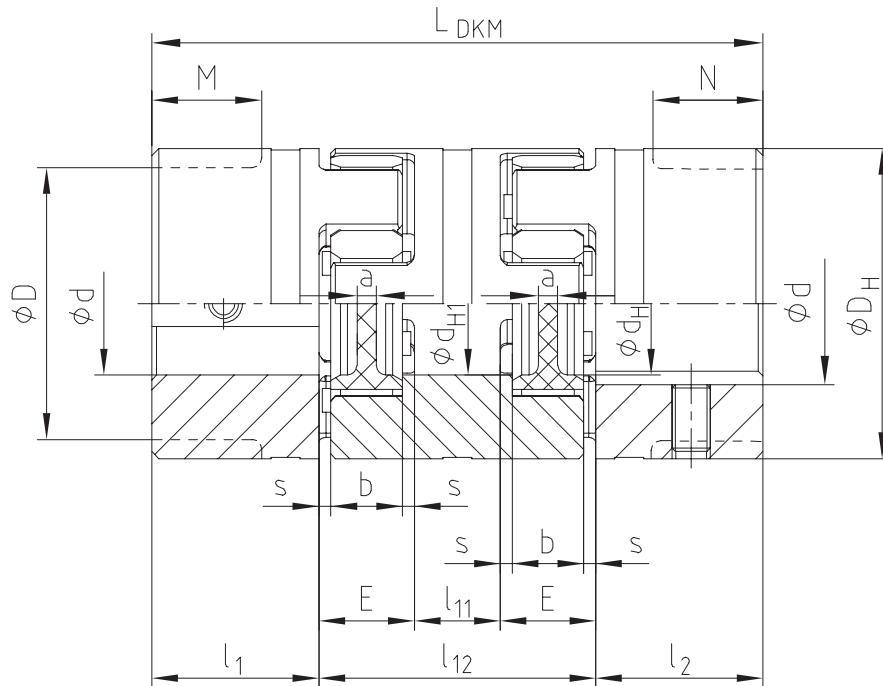

Other types:

ROTEX® GS - CF - DKM

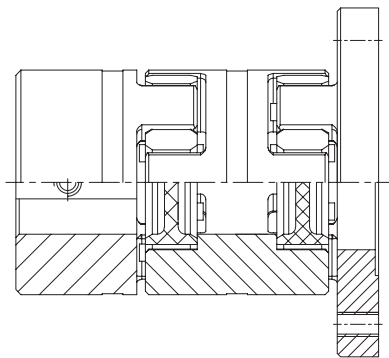

ROTEX® GS DKM with
clamping hub DH type 7.5/7.6

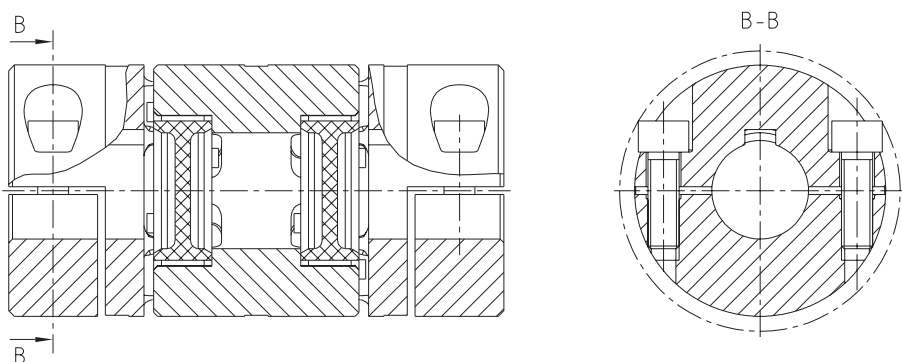

ROTEX® GS ZR3

Backlash-free intermediate shaft couplings

Intermediate shaft coupling with aluminium pipe bonded

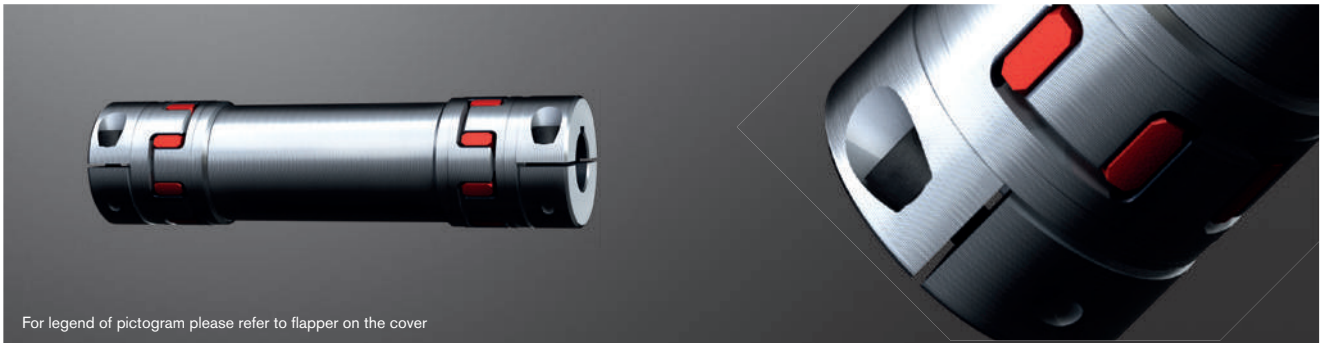

For legend of pictogram please refer to flapper on the cover



ROTEX® GS Type ZR3 - Hub material aluminium/intermediate pipe material aluminium

Size	Dimensions [mm]														Cap screw DIN EN ISO 4762	
	d _{max.}	D _H	l ₁	L	l ₃	E	L _R		L _{ZR} = L _R + 2 · l ₃		d _R	D _K	t ₁	e	M	T _A [Nm]
							Min.	Max.	Min.	Max.						
14	15	30	18.5	36.0	14.5	13	72	2971	101	3000	28	33.3	7.5	10.5	M4	2.9
19	20	40	25	49.0	17.5	16	98	2965	133	3000	40	46	8.0	14.5	M6	10
24	28	55	30	59.0	22.0	18	121	3456	165	3500	50	57.5	10.5	20	M6	10
28	38	65	35	67.0	25.0	20	137	3950	187	4000	60	73	11.5	25	M8	25
38	45	80	45	83.5	33.0	24	169	3934	235	4000	70	83.5	15.5	30	M8	25
42	50	95	50	93.0	36.5	26	180	3927	253	4000	80	93.5	18.0	32	M10	49
48	55	105	56	100.0	39.5	28	202	3921	281	4000	100	105	18.5	36	M12	86

Technical data of type ZR3

Size	Spider GS ¹⁾ torque T _{KN} [Nm]		Moment of inertia [10 ⁻³ kgm ²]			Static torsion spring stiffness [Nm/rad]
	98 ShA	64 ShD	Hub ²⁾		Pipe/meter	ZW C ₂
14	12.5	16.0	0.00362	0.00238	0.088	858
19	21.0	26.0	0.02002	0.01304	0.329	3243.6
24	60.0	75.0	0.07625	0.04481	0.673	6631.8
28	160	200	0.17629	0.10950	1.199	11814.1
38	325	405	0.50385	0.2572	2.972	29290.4
42	450	560	1.12166	0.5523	4.560	44929.7
48	525	655	1.87044	1.1834	9.251	91158.2

¹⁾ For selections see page 22 et seqq/other spiders see page 123 and following

²⁾ With d_{max.}

³⁾ Torsion spring stiffness with a length of 1 m of intermediate pipe with L_{pipe} = L_{ZR} - 2 · L

For inquiries and orders please specify the shaft distance dimension L_R along with the maximum speed to review the critical bending speed. See diagramme on page 127.

The intermediate pipe can be combined with other hub designs, but in that case it can no longer be radially disassembled. Please specify the shaft distance dimension required in your order.

With vertical application a support washer has to be used (please specify in your order).

Insertion dimension of shaft l₃, to make sure that the coupling can be assembled/disassembled radially.

Straightness/concentricity of pipes according to DIN EN 755-1.

Review of shaft-hub-connection: Friction torques T_R [Nm] for hub design 7.5

Size	Ø5	Ø6	Ø8	Ø10	Ø11	Ø14	Ø15	Ø16	Ø18	Ø19	Ø20	Ø22	Ø24	Ø25	Ø28	Ø30	Ø32	Ø35	Ø38	Ø40	Ø42	Ø45	Ø46	Ø48	Ø50	Ø55
14	4.6	5.5	7.4	9.2	10.1	12.9	13.8																			
19			17	21	23	30	32	34	38	40	42															
24				21	23	30	32	34	38	40	42	47	51	53	59											
28					54	58	62	70	74	78	86	93	97	109	117	124	136	148								
38								70	74	78	86	93	97	109	117	124	136	148	156	163	175					
42											136	149	155	174	186	198	217	235	248	260	279	285	297	310		
48											199	217	226	253	271	290	317	344	362	380	407	416	434	452	498	

Ordering
example:

ROTEX® GS 24	ZR3	1200 mm	98 ShA-GS	7.5 - Ø24	7.5 - Ø24
Coupling size	Type	Shaft distance dimension (L _R)	Spider hardness	Hub design	Finish bore

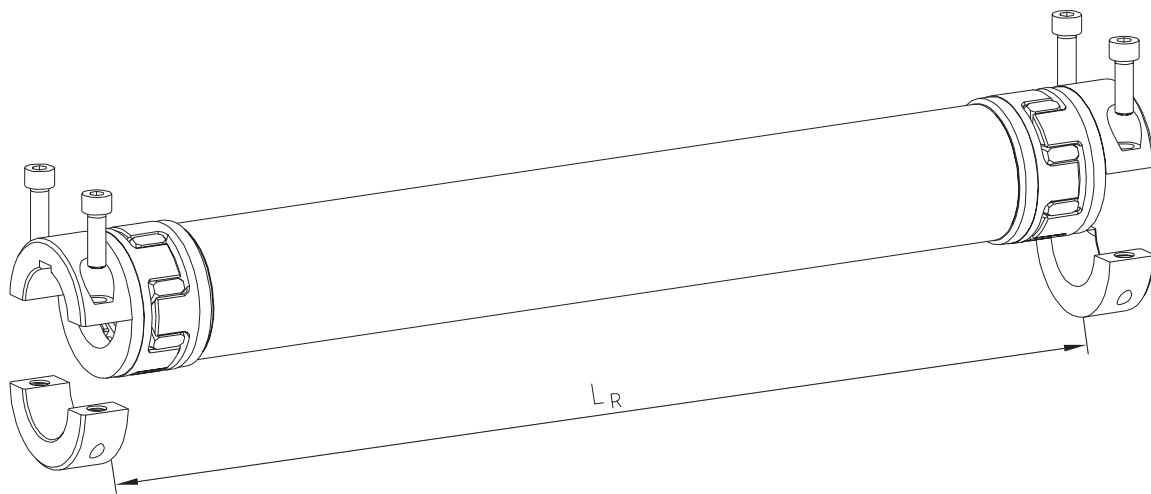
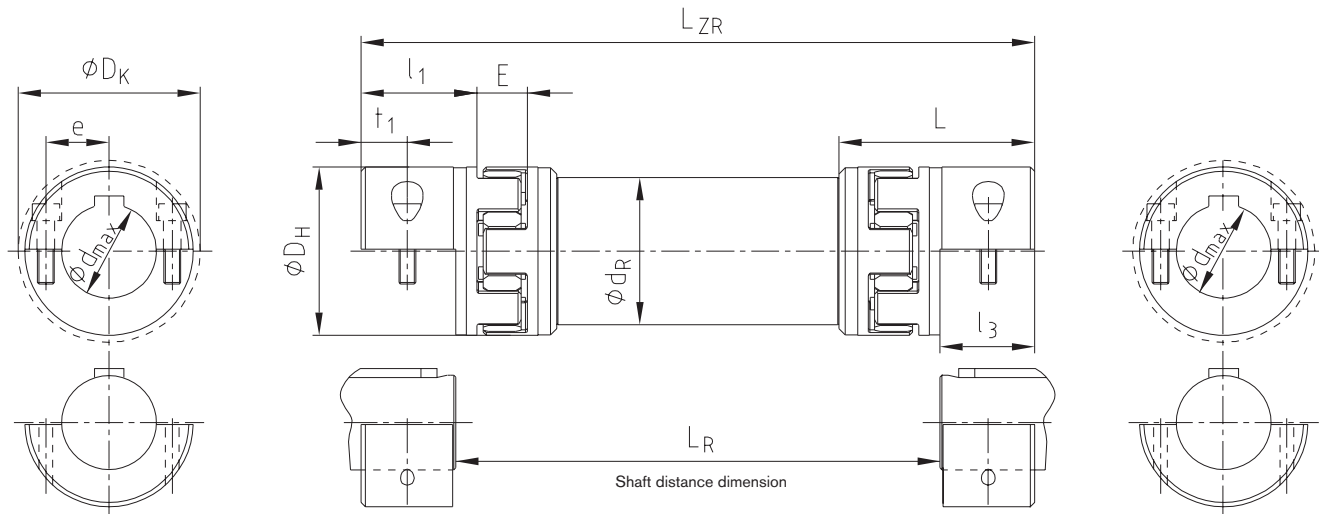

Types of hubs

Type 7.5

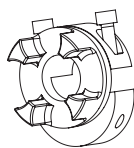

Clamping hub type DH without feather keyway for double-cardanic connections

Type 7.6

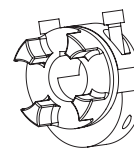

Clamping hub type DH with feather keyway for double-cardanic connections

ROTEX® GS ZR1 and ZR2

Backlash-free intermediate shaft couplings

Intermediate shaft couplings with steel pipe/steel shaft

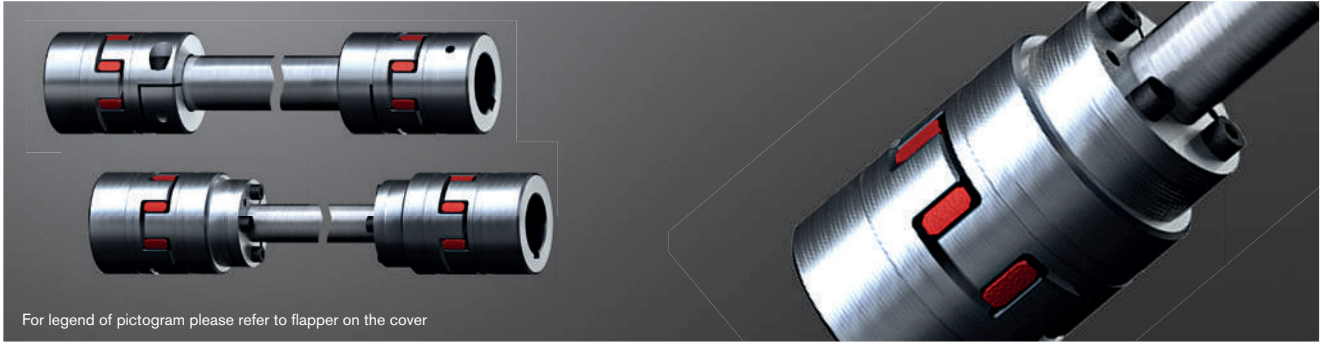

For legend of pictogram please refer to flapper on the cover



ROTEX® GS Type ZR1																		
Size	Spider GS ¹⁾ torque T _{KN} [Nm]		Dimensions [mm]													Cap screw DIN EN ISO 4762		Friction torque T _R [Nm]
	98 ShA	64 ShD	d _{max.} ²⁾	D _H	l ₁ , l ₂	L	E	b	s	B	LR1	Minimum dimension for LR1	LZR1	d _R ³⁾	M	T _A [Nm]		
14 ZR1	12.5	16.0	16	30	11	35	13	10	1.5	11.5	Please specify with inquiries and orders.	71	LR1+22	14x2.5	M3	1.34	6.1	
19 ZR1	21.0	26.0	24	40	25	66	16	12	2.0	14.0		110	LR1+50	20x3.0	M6	10.5	34	
24 ZR1	60	75	28	55	30	78	18	14	2.0	16.0		128	LR1+60	25x2.5	M6	10.5	45	
28 ZR1	160	200	38	65	35	90	20	15	2.5	17.5		145	LR1+70	35x4.0	M8	25	105	
38 ZR1	325	405	45	80	45	114	24	18	3.0	21.0		180	LR1+90	40x4.0	M8	25	123	

ROTEX® GS Type ZR2																				
Size	Spider GS ¹⁾ torque T _{KN} [Nm]		Dimensions [mm]													Precision tube [mm] [Nm/rad]		Clamping set size KTR 250	Clamping screws DIN EN ISO 4762	Tightening torque T _A [Nm]
	98 ShA	64 ShD	d _{max.} ²⁾	D _H	l ₁ , l ₂	l ₃	L	E	b	s	B	LR2	Minimum dimension for LR2	LZR2	d _R ³⁾	C ₂ ⁴⁾	dxD			
14 ZR2	12.5	16.0	16	30	11	26	50	13	10	1.5	11.5	Please specify with inquiries and orders.	109	LR2+22	10x2.0	68.36	10x16	M4	5.6	
19 ZR2	21.0	26.0	24	40	25	26	67	16	12	2.0	14.0		120	LR2+50	12x2.0	130	12x18	M4	5.6	
24 ZR2	60	75	28	55	30	38	86	18	14	2.0	16.0		156	LR2+60	20x3.0	954.9	20x28	M6	17.0	
28 ZR2	160	200	38	65	35	45	100	20	15	2.5	17.5		177	LR2+70	25x2.5	1811	25x34	M6	17.0	
38 ZR2	325	405	45	80	45	45	114	24	18	3.0	21.0		192	LR2+90	32x3.5	5167	32x43	M6	17.0	
42 ZR2	450	560	55	95	50	52	128	26	20	3.0	23.0		214	LR2+100	40x4.0	11870	40x53	M6	17.0	
48 ZR2	525	655	62	105	56	70	154	28	21	3.5	24.5		261	LR2+112	45x4.0	17486	45x59	M8	41.0	
55 ZR2	685	825	74	120	65	80	175	30	22	4.0	26.0		288	LR2+130	55x4.0	33543	55x71	M8	41.0	
65 ZR2	940	1175	80	135	75	80	185	35	26	4.5	30.5	387	LR2+150	60x4.0	44362	60x77	M8	41.0		

¹⁾ For selections see page 22 et seqq/other spiders see page 123 and following

²⁾ Dependent on type of hub. Hub types can be freely selected, for summary see page 128.

³⁾ Has to be remachined, if necessary.

⁴⁾ Torsion spring stiffness with a length of 1 m of intermediate pipe.

For inquiries and orders please specify the shaft distance dimension LR₁/LR₂ along with the maximum speed to review the critical bending speed.

With vertical application a support washer has to be used (please specify in your order).

Straightness/concentricity of pipes according to DIN EN 10305-1.

Ordering example:	ROTEX® GS 24	ZR1	1000 mm	98 ShA-GS	1.0 - Ø24	2.5 - Ø24	
	Coupling size	Type	Shaft distance dimension (LR ₁ /LR ₂)	Spider hardness	Hub design	Finish bore	Hub design

Type ZR1

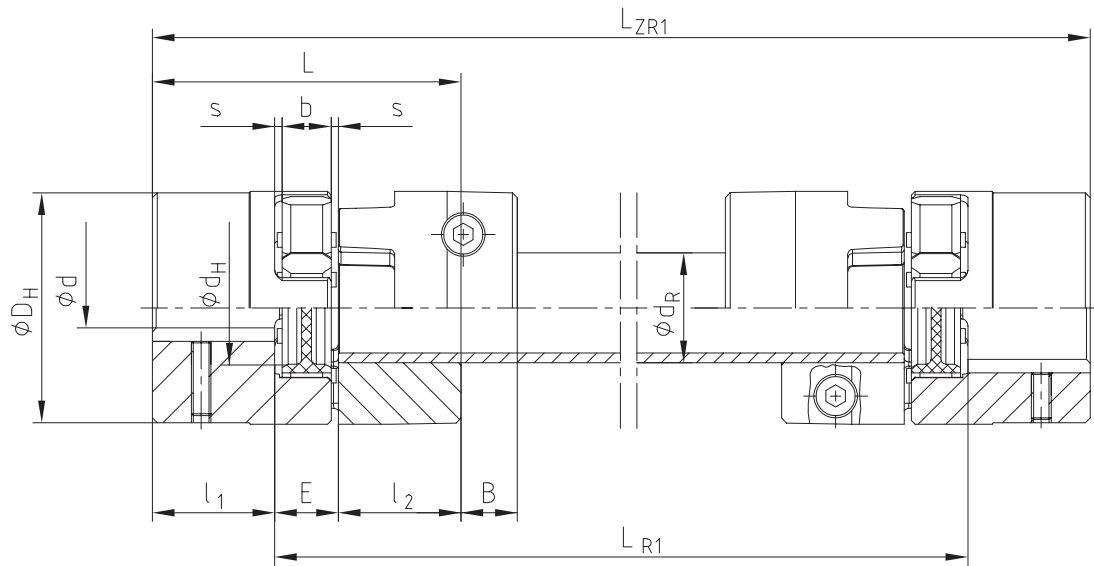

Type ZR2

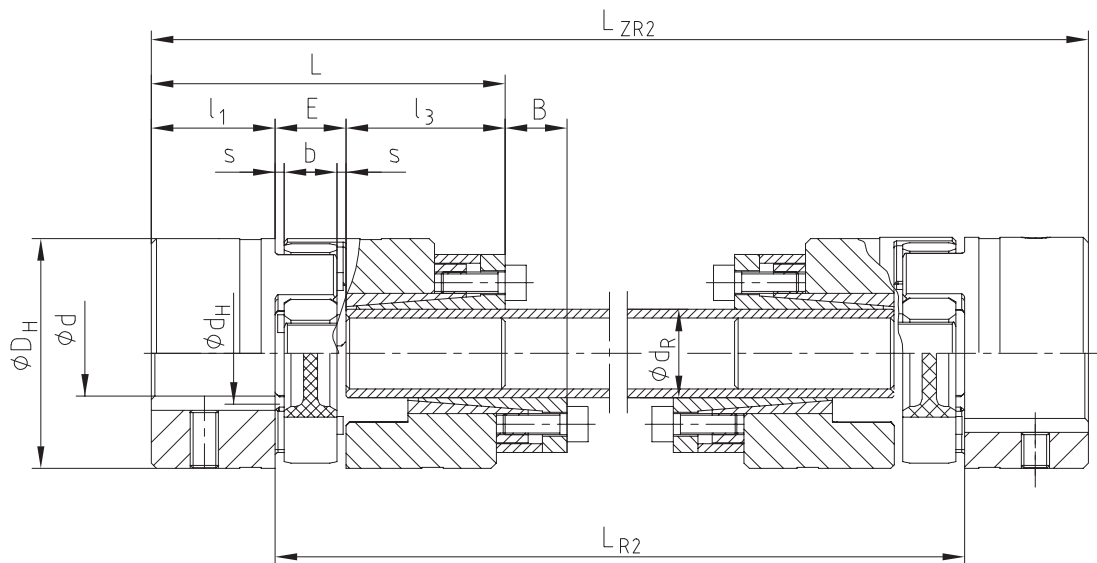

KTR-STOP® NC

Hydraulic clamping system

Safety clamping and braking system



Description of product:

The KTR-STOP® NC series is a passive clamping and braking system. It serves for generating a clamping/braking force respectively a clamping/braking torque on a cylindrical piston rod or shaft. This results in a deceleration of the rotary motion respectively keeping at standstill.

Applications:

Machine tool

- Ball screws/positioning axes
- Rod guidances

Drive technology

- Feed cylinders

General engineering

- Hoists, hydraulic presses
- Rod, piston, shaft clamping
- Lifting tables/scissors lifts
- Hydraulic lifts/hydraulic lifting device

General

- Safety catches
- Blocking systems
- Systems that require additional safety devices

Product features:

- Passive clamping and braking system with fail-safe function
- System with hydraulic release
- Absorbing axial loads and torques
- Reduction of vibrations subject to increased stiffness in spindle drives
- Clamping bush replaceable
- To be used as an integrated solution or as a plug-in system
- To be used multifunctionally (machine tool, general engineering ...)
- Clamping with an indefinite period of time due to the spring pressure memory
- Energy-saving due to weak locking in unpressurized condition → spring pressure memory
- No generation of heat
- Operating principle of friction fit

Specifications of piston rod/ball screw		
	Steel, hard chromium plated	Steel, hardened
Coating thickness	Min. 20 µm	-
Hardness	-	Min. HRC 60
Surface finish		Ra < 0.4 µm
Yield strength R _e		> 400 N/mm ²
Diameter tolerance		k6

Ordering example:	KTR-STOP® NC	32	-	20	100 bar
	Designation	Size		Shaft diameter	Opening pressure

A-A

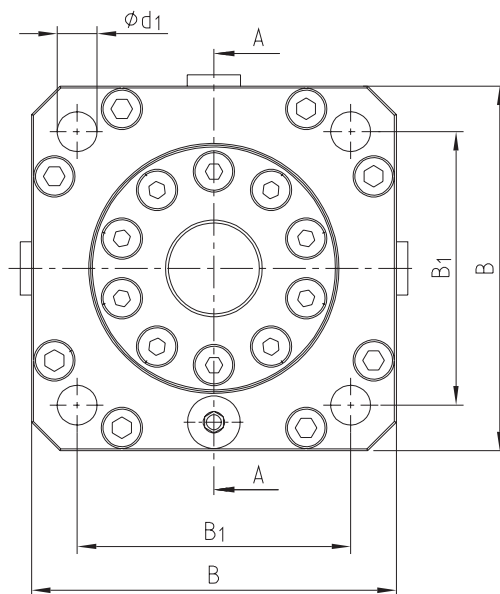
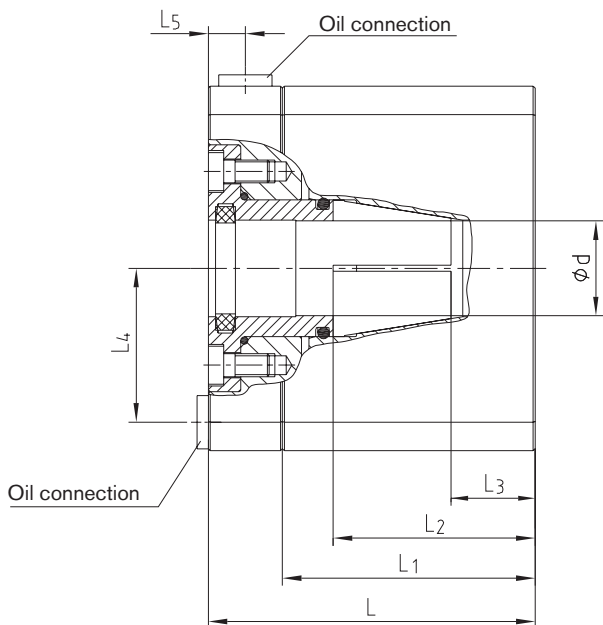

KTR-STOP® NC 1)																			
Size	Dimensions [mm]										Weight [kg]	Oil connection [l]	"Open oil filling" [dm³]	Opening pressure 50 bar		Opening pressure 70 bar		Opening pressure 100 bar	
	d 2)	d1	B	B1	L	L1	L2	L3	L4	L5				Lock torque 3)	"Axial locking force" 3)	Lock torque 3)	"Axial locking force" 3)	Lock torque 3)	"Axial locking force" 3)
NEW 25	12													12.5		16.5		27.5	
	15													15.5		20.5		34.5	
	18	9	80x80	56.5	75	58	44.5	17.5	-	8.5	3.25	G 1/8	0.0055	18.5	2100	25	2750	41	4600
	20													20.5		27.5		45	
	22													22.5		30		50	
32	18													35.5		50		75	
	20													40		56		83	
	22	10.5	96x96	72	86	66.5	53	19	40.5	10	5.25	G 1/8	0.011	43.5	4000	62	5600	91.5	8400
	24													47.5		67.5		100	
	25													50		70		105	
NEW 40	22													60.5		97.5		120	
	24													66		105		130	
	25													69		110		135	
	28													77		125		155	
	30	10.5	120x120	89	108	87.5	60	28	50	9.75	10	G 1/8	0.0137	82.5	5500	132.5	9000	165	11000
	32													88		142.5		175	
	34													93.5		150		185	
	35													96.5		155		190	
NEW 50	36													100		160		200	
	25													130		200		300	
	28													145		225		335	
	30													155		240		355	
	32													165		257.5		380	
	34	13.5	150x150	110	125	103.5	70	29	60	9.75	19	G 1/4	0.0311	175	10500	275	16250	405	24000
	35													182.5		280		415	
	36													190		290		430	
NEW 63	38													200		305		450	
	40													210		325		475	
	36													205		365		530	
	38													215		385		560	
	40													230		405		590	
	42													240		425		615	
	44													250		445		645	
	45	17.5	180x180	140	140	110	83.75	24.75	75	15	29.6	G 1/4	0.0498	255	11500	455	20500	660	29500
	46													265		465		675	
	48													275		485		705	
50													285		505		735		
52													300		525		765		
54													310		545		795		
55													315		555		810		

1) All catalogue figures refer to a fit combination shaft k6; bush D8, for other specifications see page 150

2) Other bores on request

3) Referring to a coefficient of friction of $\mu = 0.12$

Apart from the standard programme customized solutions are available on request.

TOOLFLEX®

Metal bellow-type couplings

Technical description

TOOLFLEX® is a metal bellow-type coupling, a coupling system which has proven in the field with numerous applications. The metal bellow compensates perfectly for axial, radial and angular displacements. At the same time its geometric shape allows for high torsional stiffness and a low mass moment of inertia. TOOLFLEX® is manufactured in twelve sizes for maximum torques up to 600 Nm. Its main application ranges are both positioning drives, e. g. ball spindles with a high incline, and indexing tables or planetary and worm gears with small gear ratios.

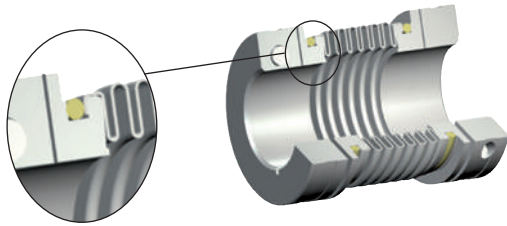

Subject to its proven bonding technique a non-positive, backlash-free connection of the aluminium hubs with the multilayer bellows made of stainless steel is generated. The flanged insert connection for sizes 16 to 55 ensures torque transmission of every single bellow layer. Since TOOLFLEX® is a metal coupling, it remains fatigue-endurable in the high-temperature range up to a maximum of 200 °C. Apart from that it is resistant to the effect of media or critical operating conditions, respectively.

The well-known shaft-hub-connection by means of clamping hubs ensures an easy assembly by a radial clamping screw. Subject to two slots in the hub there is no deformation of the bellow when tightening the clamping screw. For higher friction torques type KN with taper hubs can be used.

Double slotted clamping hub

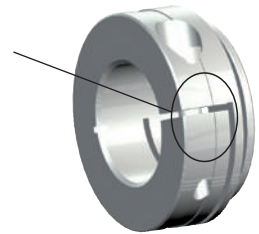

Types



Summary																				
Size	Type	Bellow-hub-connection	Thread for setscrews (hub design 1.0/1.1)			Clamping hubs (hub design 2.5/2.6)			KN			PI			CF					
			Torque of bellow T _{KN} [Nm]	Torque of bellow T _K max [Nm]	Max. speed [rpm]	Torque of bellow T _{KN} [Nm]	Torque of bellow T _K max [Nm]	Max. speed [rpm]	Torque of bellow T _{KN} [Nm]	Torque of bellow T _K max [Nm]	Max. speed [rpm]	Torque of bellow T _{KN} [Nm]	Torque of bellow T _K max [Nm]	Max. speed [rpm]	Torque of bellow T _{KN} [Nm]	Torque of bellow T _K max [Nm]	Max. speed [rpm]			
5	S	Bonded Maximum ambient temperature 100 °C	0.1	0.15	47700															
	M																			
7	S								1	1.5	31800									
	M																			
9	S								1.5	2.25	23800									
	M																			
12	S				2	3	19000													
	M																			
16	S				5	7.5	14900													
	M																			
20	S				15	22.5	11900				15	22.5	11950							
	M																			
30	S	Flanged Maximum ambient temperature 200 °C				35	52.5	8700	35	52.5	15280	35	52.5	8700	35	52.5	8700			
	M																			
38	S					65	97.5	7350	65	97.5	12600	65	97.5	7350	65	97.5	7350			
	M																			
42	S					95	142.5	6820	95	142.5	11580	95	142.5	6820	95	142.5	6820			
	M																			
45	S				170	255	5750	170	255	9300	170	255	5750	170	255	5750				
	M																			
55 Al	S				340	510	4800													
	M																			
55	S	Welded Maximum ambient temperature 200 °C				340	510	4800	340	510	7870	340	510	4800						
	M																			
65	S					600	900	3850												
	M																			

TOOLFLEX®

Metal bellow-type couplings

Types of hubs

Due to the numerous applications of TOOLFLEX® for many different applications and mounting situations, this coupling system is available with various hub designs and two different lengths of bellows. A combination of the components forms a type. TOOLFLEX® is supplied as a complete unit; a supply of individual components is not possible.



Type 1.0
with feather keyway and setscrew
Positive-locking power transmission. Permissible torque depending on the permissible surface pressure. Not suitable for backlash-free power transmission with heavily reversing operation.



Type 1.1
without feather keyway, with setscrew
Non-positive torque transmission. Suitable for backlash-free transmission of very small torques.



Type 1.3
with spline bore
Positive-locking power transmission. Spline on request of customers (e. g. for shaft with flattening).

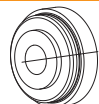

Type 1.2
without feather keyway, without setscrew
For low torques. Suitable for bonding or pressing onto the shaft.



Type 2.5 clamping hub
double slotted, without feather keyway
Frictionally engaged, backlash-free shaft-hub-connection. Transmittable torques depending on bore diameter.



Type 2.6 clamping hub
double slotted, with feather keyway
Positive-locking power transmission with additional friction fit. The friction fit avoids or reduces reverse backlash. Surface pressure of the keyway connection is reduced.

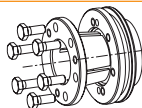

Type 6.5 taper hub KN
Integrated frictionally engaged shaft-hub-connection for the transmission of higher torques in the area of the shaft-hub-connection.

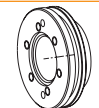

Flange
Flange to connect to customer's component. Special dimensions on request.



Type 7.5 clamping hub type DH
without feather keyway for double-cardanic connection
Frictionally engaged, backlash-free shaft-hub-connection for radial assembly of coupling. Transmittable torques depending on bore diameter.

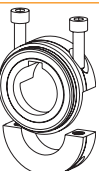

Type 7.6 clamping hub type DH
with feather keyway for double-cardanic connection
Positive-locking power transmission with additional friction fit for radial assembly of coupling. The friction fit avoids or reduces reverse backlash. Surface pressure of the keyway connection is reduced.



Type 7.8 clamping hub type H
without feather keyway for single-cardanic connection
Frictionally engaged, backlash-free shaft-hub-connection for radial assembly of coupling. Transmittable torques depending on bore diameter.



Type 7.9 clamping hub type H
with feather keyway for single-cardanic connection
Positive-locking power transmission with additional friction fit for radial assembly of coupling. The friction fit avoids or reduces reverse backlash. Surface pressure of the keyway connection is reduced.

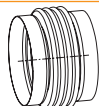

Bellow type S
Bellow with 4 layers made of stainless steel; compact design with high torsion spring stiffness.

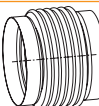

Bellow type M
Bellow with 6 layers made of stainless steel; realizing large shaft distance dimensions and displacements.

Special designs on request of customers

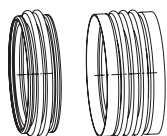

Special bellows
Bellows with 1, 2 or 3 layers available on request.

TOOLFLEX® S

Metal bellow-type couplings

Type S: Hubs with threads for setscrews



For legend of pictogram please refer to flapper on the cover

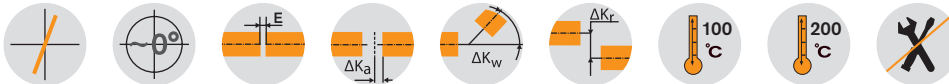

TOOLFLEX® S type 1.1

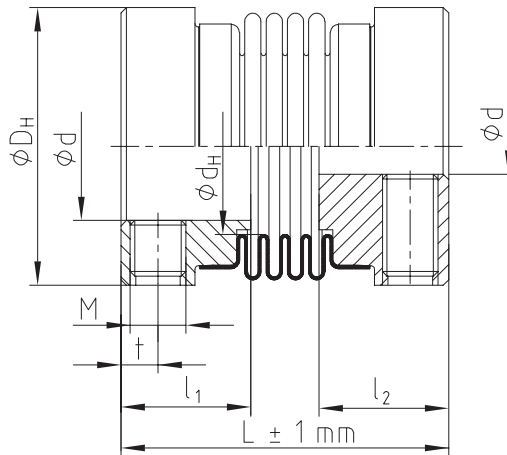

TOOLFLEX® S with thread for setscrews (type 1.1) - Hub material aluminium/bellow material stainless steel

Size	Bellow-hub-connection	Torque of bellow T_{KN} ¹⁾ [Nm]	Max. speed [rpm]	Dimensions [mm]									Perm. displacements			Torsion spring stiffness C_T [Nm/rad]	Weight ³⁾ [kg]
				Finish bore d		General				Thread for setscrews			Axial [mm]	Radial [mm]	Angular [degree]		
				Min.	Max.	D_H	d_H	L	l_1, l_2	M	t	z = number ²⁾					
5		0.1	47700	2	5	10	6	15	6	M2	1.8	1	±0.30	0.10	0.7	97	0.0027
7	4)	1.0	31800	3	8	15	9	18	7	M3	2.0	1	±0.30	0.10	0.7	390	0.005
9		1.5	23800	3	10	20	12	21	8	M3	2.2	2	±0.35	0.15	1.0	750	0.010
12		2.0	19000	4	14	25	16	27.5	11	M4	2.8	2	±0.40	0.15	1.0	1270	0.017
16	5)	5.0	14900	5	18	32	20	37	13	M5	4	2	±0.30	0.15	1.0	4500	0.046
20		15	11900	6	25	40	27	42	15	M5	5	2	±0.40	0.15	1.0	9600	0.076

¹⁾ For selection see page 22 et seqq.

²⁾ Number each hub; from size 9: 2 x 120° offset.

³⁾ Figures refer to the complete coupling with max. bore.

⁴⁾ Bonded

⁵⁾ Flanged

Types of hubs

Type 1.0



Hub with feather keyway and setscrew

Type 1.1



Hub without feather keyway, with setscrew

Type 1.2

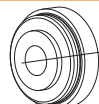

Hub without feather keyway, without setscrew

Type 1.3

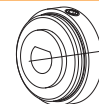

Hub with spline bore

Ordering example:

TOOLFLEX® 7 S	1.1 - Ø4		1.1 - Ø6	
Size and type of coupling	Hub design	Finish bore	Hub design	Finish bore

TOOLFLEX® M

Metal bellow-type couplings

Type M: Hubs with threads for setscrews

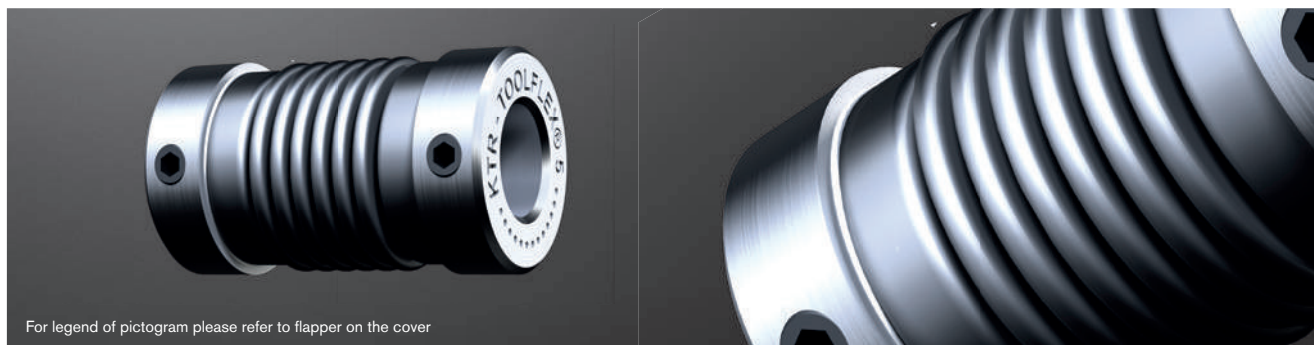

For legend of pictogram please refer to flapper on the cover

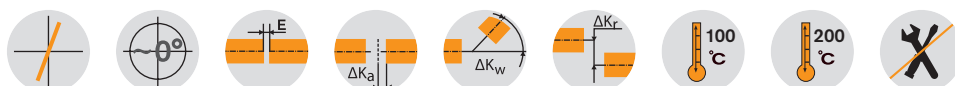

TOOLFLEX® M type 1.1

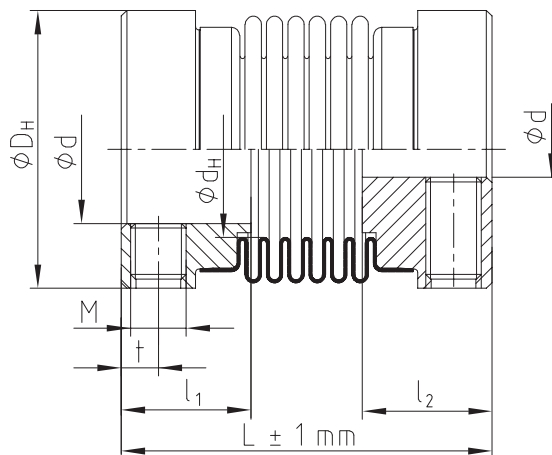

TOOLFLEX® M with thread for setscrews (type 1.1) - Hub material aluminium/bellow material stainless steel

Size	Bellow-hub-connection	Torque of bellow T_{KN} ¹⁾ [Nm]	Max. speed [rpm]	Dimensions [mm]										Perm. displacements			Torsion spring stiffness C_T [Nm/rad]	Weight ³⁾ [kg]
				Finish bore d		General				Thread for setscrews				Axial [mm]	Radial [mm]	Angular [degree]		
				Min.	Max.	D_H	d_H	L	l_1, l_2	M	t	z = number ²⁾						
5		0.1	47700	2	5	10	6	17	6	M2	1.8	1	±0.40	0.15	1.0	75	0.003	
7	4)	1.0	31800	3	8	15	9	20	7	M3	2.0	1	±0.40	0.15	1.0	300	0.006	
9		1.5	23800	3	10	20	12	24	8	M3	2.2	2	±0.50	0.20	1.5	580	0.011	
12		2.0	19000	4	14	25	16	31	11	M4	2.8	2	±0.60	0.20	1.5	980	0.019	
16	5)	5.0	14900	5	18	32	20	41	13	M5	4	2	±0.50	0.20	1.5	3050	0.049	
20		15	11900	6	25	40	27	49	15	M5	5	2	±0.60	0.20	1.5	6600	0.082	

¹⁾ For selection see page 22 et seqq.

²⁾ Number each hub; from size 9: 2 x 120° offset.

³⁾ Figures refer to the complete coupling with max. bore.

⁴⁾ Bonded

⁵⁾ Flanged

Types of hubs

Type 1.0



Hub with feather keyway and setscrew

Type 1.1



Hub without feather keyway, with setscrew

Type 1.2

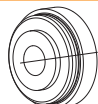

Hub without feather keyway, without setscrew

Type 1.3



Hub with spline bore

Ordering example:

TOOLFLEX® 7 M	1.1 - Ø4		1.1 - Ø6	
Size and type of coupling	Hub design	Finish bore	Hub design	Finish bore

TOOLFLEX® S

Metal bellow-type couplings

Type S: with clamping hubs



For legend of pictogram please refer to flapper on the cover

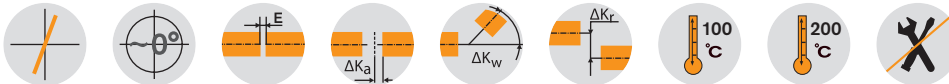

TOOLFLEX® Type S with clamping hubs - Hub material aluminium (size 55/65 steel)/bellow material stainless steel

Size	Dimensions [mm]											
	Finish bore d		General					Clamping screws DIN EN ISO 4762				
	Min.	Max.	L	I ₁ , I ₂	E	D _H	d _H	M ₁	D ₃	t ₁	e ₁	T _A [Nm]
7	3	7	24	9	6	15	9	M2	16.5	3.2	5	0.37
9	3	9	29	11	7	20	12	M2.5	21.5	3.5	7.1	0.76
12	4	12	34.5	13	8.5	25	16	M3	26.5	4	8.5	1.34
16	5	16	45	17.0	11	32	20	M4	35.0	5	12.0	2.9
20	8	20	55	21.5	12	40	27	M5	43.5	6	14.5	6
30	10	30	63	23.0	17	55	33	M6	58.0	7	19	10
38	12	38	69	25.5	18	65	42	M8	72.6	9	25	25
42	14	42	84	30.0	24	70	46	M8	76.1	9	27	25
45	14	45	86.5	32.0	22.5	83	58	M10	89.0	11	30	49
55 Al	20	55	111	40.0	31	100	73	M12	106.0	14	37	86
55 ³⁾	20	55	111	40.0	31	100	73	M12	106.0	14	37	120
65 ³⁾	30	65	126	45.0	36	125	95	M14	127.2	15	45	185

Technical data

Size	Bellow-hub-connection	Torque of bellow T _{KN} [Nm] ¹⁾	Max. speed [rpm]	Hub material	Moment of inertia ²⁾ [x10 ⁻⁸ kgm ²]	Torsion spring stiffness C _T [Nm/rad]	Axial stiffness C _A [N/mm]	Radial stiffness C _R [N/mm]	Perm. displacements			Weight ²⁾ [kg]
									Axial [mm]	Radial [mm]	Angular [degree]	
7	Bonded	1	31800	Aluminium	0.26	390	—	—	±0.3	0.10	0.7	0.007
9		1.5	23800	Aluminium	0.97	750	—	—	±0.35	0.15	1.0	0.014
12		2	19100	Aluminium	2.6	1270	—	—	±0.4	0.15	1.0	0.025
16		5	14900	Aluminium	9	4500	43	138	±0.3	0.15	1.0	0.06
20		15	11950	Aluminium	30	9600	63	189	±0.4	0.15	1.0	0.12
30	Flanged	35	8700	Aluminium	114	17800	97	233	±0.5	0.20	1.5	0.24
38		65	7350	Aluminium	245	37400	108	318	±0.6	0.20	1.5	0.35
42		95	6820	Aluminium	396	54700	120	499	±0.6	0.20	1.5	0.49
45		170	5750	Aluminium	931	95800	132	738	±0.9	0.20	1.5	0.82
55 Al		340	4800	Aluminium	1665	144100	160	894	±1.1	0.25	1.5	1.50
55 ³⁾	340	4800	Steel	4996	144100	160	894	±1.0	0.25	1.5	3.20	
65 ³⁾	600	3850	Steel	13318	322740	212	1365	±1.0	0.30	1.5	5.50	

¹⁾ For selection see page 22 et seqq.

²⁾ Figures refer to the complete coupling with max. bore.

³⁾ Hub made of steel welded with bellow.

Review of shaft-hub-connection: Friction torques T_R [Nm] for hub design 2.5

Size	Ø3	Ø4	Ø5	Ø6	Ø7	Ø8	Ø9	Ø10	Ø11	Ø12	Ø14	Ø15	Ø16	Ø18	Ø19	Ø20	Ø24	Ø25	Ø28	Ø30	Ø32	Ø35	Ø38	Ø40	Ø42	Ø45	Ø50	Ø55	Ø60	Ø65	
7	0.84	0.91	0.97	1.04	1.10																										
9	1.87	1.98	2.09	2.20	2.31	2.41	2.52																								
12		3.48	3.65	3.81	3.98	4.14	4.31	4.48	4.64	4.81																					
16			8.5	8.8	9.1	9.4	9.7	9.9	10.2	10.5	11.1	11.4	11.7																		
20						17.6	18.1	18.6	19.1	19.5	20.5	21.0	21.4	22.4	22.9	23.3															
30									33.1	33.8	35.1	35.8	36.5	37.8	38.5	39.2	41.9	42.5	44.6	45.9											
38											79.2	80.4	81.7	84.2	85.4	86.6	91.6	92.8	96.5	99.0	102	105	109								
42											84.2	85.4	86.6	89.1	90.3	91.6	96.5	97.8	102	104	106	110	114	116	119						
45												157	165	167	173	177	181	187	193	197	200	206									
55 Al																270	281	284	293	298	304	313	321	327	333	341	356	371			
55 ³⁾																	397	401	413	421	429	442	454	462	470	482	502	523			
65 ³⁾																					720	732	750	768	780	792	810	840	870	900	930

Ordering example:	TOOLFLEX® 30 S	2.5	Ø25	2.5	Ø30
	Size and type of coupling	Hub design	Finish bore	Hub design	Finish bore

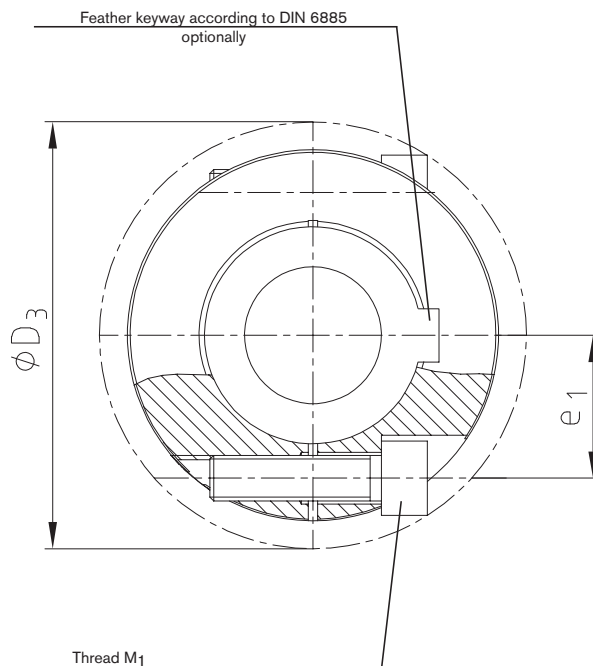
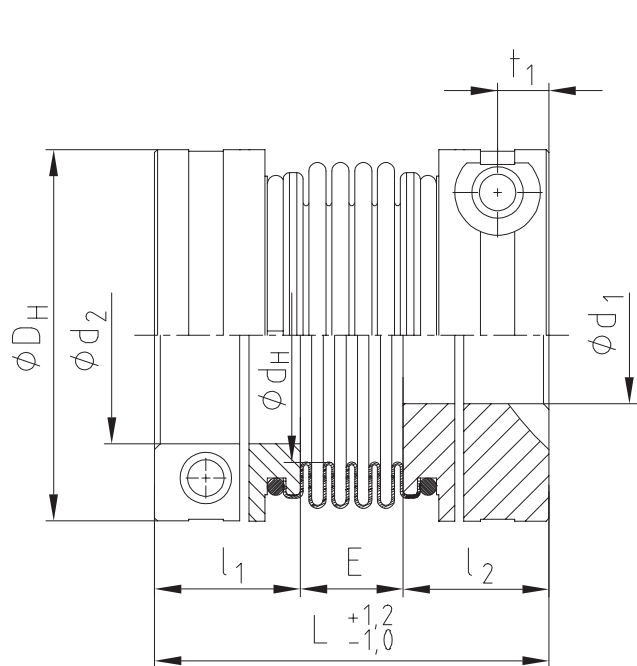

ROTEX® GS

TOOLFLEX®

Backlash-free
servo couplings

Other types:
Type for FANUC motors

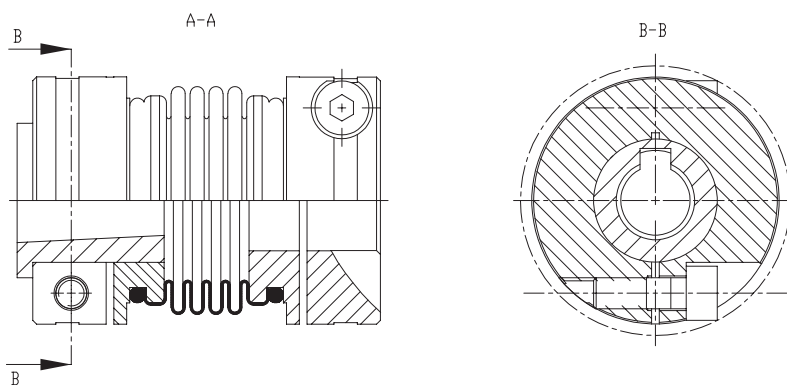

RADEX®-NC

Types of hubs

Type 2.5

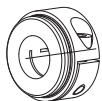

Clamping hub double slot without feather keyway

Type 2.6



Clamping hub double slot with feather keyway

COUNTEX®

TOOLFLEX® M

Metal bellow-type couplings

Type M: with clamping hubs

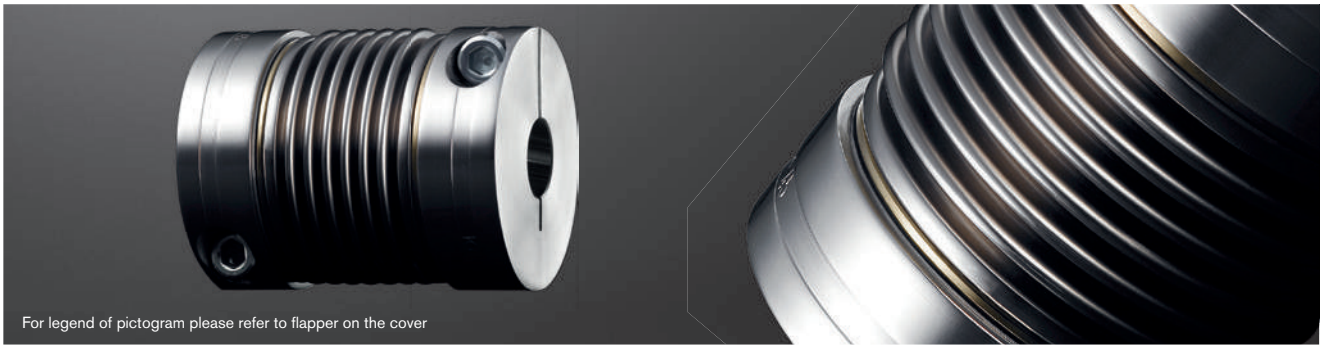

For legend of pictogram please refer to flapper on the cover

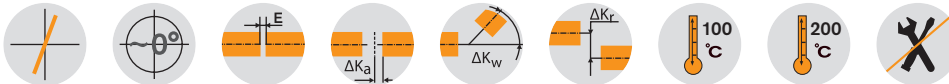

TOOLFLEX® Type M with clamping hubs - Hub material aluminium (size 55/65 steel)/bellow material stainless steel

Size	Dimensions [mm]											
	Finish bore d		General					Clamping screws DIN EN ISO 4762				
	Min.	Max.	L	l ₁ , l ₂	E	D _H	d _H	M ₁	D ₃	t ₁	e ₁	T _A [Nm]
7	3	7	26	9	8	15	9	M2	16.5	3.2	5	0.37
9	3	9	32	11	10	20	12	M2.5	21.5	3.5	7.1	0.76
12	4	12	38	13	12	25	16	M3	26.5	4	8.5	1.34
16	5	16	49	17.0	15	32	20	M4	35.0	5	12	2.9
20	8	20	62	21.5	19	40	27	M5	43.5	6	14.5	6
30	10	30	72	23.0	26	55	33	M6	58.0	7	19	10
38	12	38	81	25.5	30	65	42	M8	72.6	9	25	25
42	14	42	95	30.0	35	70	46	M8	76.1	9	27	25
45	14	45	103	32.0	39	83	58	M10	89.0	11	30	49
55 Al	20	55	125	40.0	45	100	73	M11	106.0	14	37	86
55 ³⁾	20	55	125	40.0	45	100	73	M12	106.0	14	37	120
65 ³⁾	30	65	142	45.0	52	125	95	M14	127.2	15	45	185

Technical data

Size	Bellow-hub-connection	Torque of bellow T _{KN} [Nm] ¹⁾	Max. speed [rpm]	Hub material	Moment of inertia ²⁾ [x10 ⁻⁶ kgm ²]	Torsion spring stiffness C _T [Nm/rad]	Axial stiffness C _A [N/mm]	Radial stiffness C _R [N/mm]	Perm. displacements			Weight ²⁾ [kg]
									Axial [mm]	Radial [mm]	Angular [degree]	
7	Bonded	1	31800	Aluminium	0.3	300	—	—	±0.4	0.15	1.0	0.008
9		1.5	23800	Aluminium	1.0	580	—	—	±0.5	0.20	1.5	0.015
12		2	19100	Aluminium	2.7	980	—	—	±0.6	0.20	1.5	0.03
16		5	14900	Aluminium	10	3050	29	92	±0.5	0.20	1.5	0.06
20	Flanged	15	11950	Aluminium	32	6600	42	126	±0.6	0.20	1.5	0.14
30		35	8700	Aluminium	123	14800	65	155	±0.8	0.25	2.0	0.31
38		65	7350	Aluminium	262	24900	72	212	±0.8	0.25	2.0	0.45
42		95	6820	Aluminium	427	36500	80	333	±0.8	0.25	2.0	0.52
45		170	5750	Aluminium	1020	64000	88	492	±1.0	0.25	2.0	1.13
55 Al		340	4800	Aluminium	1706	96100	107	598	±1.1	0.30	2.0	2.0
55 ³⁾	340	4800	Steel	5118	96100	107	598	±1.0	0.30	2.0	3.3	
65 ³⁾	600	3850	Steel	13727	226550	135	910	±2.0	0.35	2.0	5.6	

¹⁾ For selection see page 22 et seqq.

²⁾ Figures refer to the complete coupling with max. bore.

³⁾ Hub made of steel welded with bellow.

Review of shaft-hub-connection: Friction torques T_F [Nm] for hub design 2.5

Size	Ø3	Ø4	Ø5	Ø6	Ø7	Ø8	Ø9	Ø10	Ø11	Ø12	Ø14	Ø15	Ø16	Ø18	Ø19	Ø20	Ø24	Ø25	Ø28	Ø30	Ø32	Ø35	Ø38	Ø40	Ø42	Ø45	Ø50	Ø55	Ø60	Ø65	
7	0.84	0.91	0.97	1.04	1.10																										
9	1.87	1.98	2.09	2.20	2.31	2.41	2.52																								
12		3.48	3.65	3.81	3.98	4.14	4.31	4.48	4.64	4.81																					
16			8.5	8.8	9.1	9.4	9.7	9.9	10.2	10.5	11.1	11.4	11.7																		
20						17.6	18.1	18.6	19.1	19.5	20.5	21.0	21.4	22.4	22.9	23.3															
30									33.1	33.8	35.1	35.8	36.5	37.8	38.5	39.2	41.9	42.5	44.6	45.9											
38											79.2	80.4	81.7	84.2	85.4	86.6	91.6	92.8	96.5	99.0	102	105	109								
42											84.2	85.4	86.6	89.1	90.3	91.6	96.5	97.8	102	104	106	110	114	116	119						
45																157	165	167	173	177	181	187	193	197	200	206					
55 Al																270	281	284	293	298	304	313	321	327	333	341	356	371			
55 ³⁾																	397	401	413	421	429	442	454	462	470	482	502	523			
65 ³⁾																					720	732	750	768	780	792	810	840	870	900	930

Ordering example:	TOOLFLEX® 30 M	2.5 - Ø25				2.5 - Ø30			
	Size and type of coupling	Hub design	Finish bore	Hub design	Finish bore				

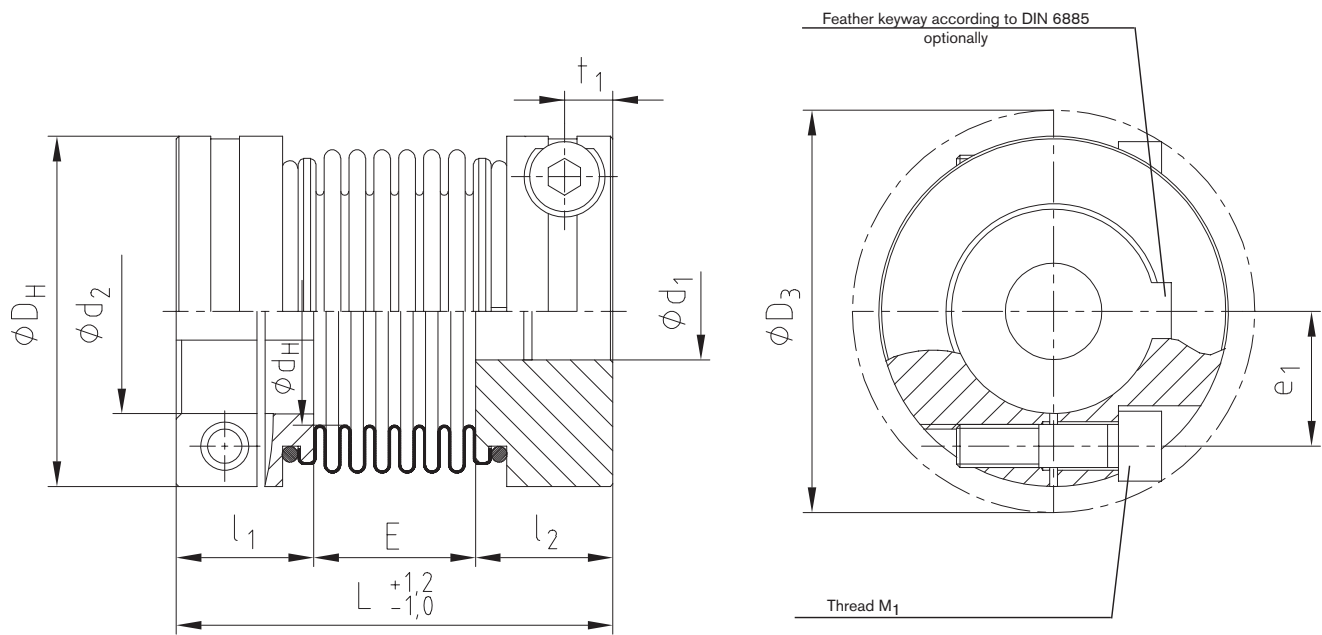

ROTEX® GS

TOOLFLEX®

Backlash-free servo couplings

Other types:
Type for FANUC motors

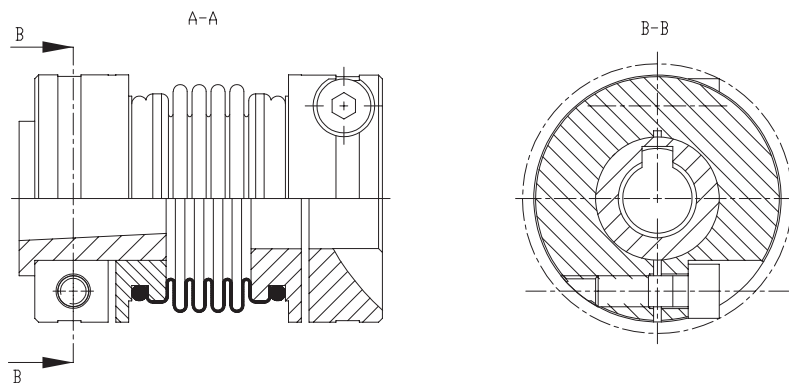

RADEX®-NC

Types of hubs

Type 2.5



Clamping hub double slot without feather keyway

Type 2.6



Clamping hub double slot with feather keyway

COUNTEX®

TOOLFLEX® KN

Metal bellow-type couplings

Taper hubs for high friction torques



For legend of pictogram please refer to flapper on the cover

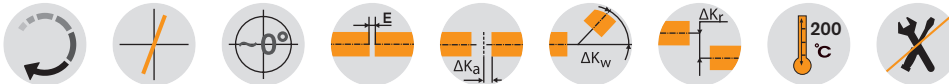

TOOLFLEX® Type S-KN - Hub material steel/bellow material stainless steel																	
Size	Torque of bellow $T_{KN}^{1)}$ [Nm]	Max. speed [rpm]	Dimensions [mm]														Weight ⁴⁾ [kg]
			Finish bore d		L	L _{total}	l _{1, l2}	DH	D ₁	D ₂	Clamping screws			Tack thread			
			Min.	Max.	4 layers	4 layers					M	T _A [Nm]	z = number	M ₁	z = number	T _{A1} ³⁾ [Nm]	
30	35	15280	12	22	48	54	22	50	43	47	M4	2.9	12	M4	6	1.2	0.4
38	65	12600	12	28	56	63	26	60.5	52	56	M5	6	12	M5	6	1.4	0.7
42	95	11580	14	35	64	71	29	66	60	63	M5	6	12	M5	6	1.4	0.8
45	170	9300	15	40	74.5	82.5	34	82	68	77	M6	14	12	M6	6	3	1.5
55 ²⁾	340	7870	15	56	95.5	106	40	97	95	95	M8	35	12	M8	6	6	2.5

TOOLFLEX® Type M-KN - Hub material steel/bellow material stainless steel																	
Size	Torque of bellow $T_{KN}^{1)}$ [Nm]	Max. speed [rpm]	Dimensions [mm]														Weight ⁴⁾ [kg]
			Finish bore d		L	L _{total}	l _{1, l2}	DH	D ₁	D ₂	Clamping screws			Tack thread			
			Min.	Max.	6 layers	6 layers					M	T _A [Nm]	z = number	M ₁	z = number	T _{A1} ³⁾ [Nm]	
30	35	15280	12	22	57	63	22	50	43	47	M4	2.9	12	M4	6	1.2	0.4
38	65	12600	12	28	68	75	26	60.5	52	56	M5	6	12	M5	6	1.4	0.7
42	95	11580	14	35	75	82	29	66	60	63	M5	6	12	M5	6	1.4	0.8
45	170	9300	15	40	91	99	34	82	68	77	M6	14	12	M6	6	3	1.5
55 ²⁾	340	7870	15	56	109	120	40	97	95	95	M8	35	12	M8	6	6	2.5

¹⁾ For selection see page 22 et seqq.

²⁾ Hub made of steel welded with bellow.

³⁾ After assembly of the clamping screws (M) tighten the tack thread (M₁) at the tightening torque T_{A1} specified.

⁴⁾ Figures refer to the complete coupling with max. bore.

Review of shaft-hub-connection: Friction torques T_R [Nm] for hub design 6.5																		
Size	Ø14	Ø15	Ø16	Ø19	Ø20	Ø24	Ø25	Ø28	Ø30	Ø32	Ø35	Ø38	Ø40	Ø42	Ø45	Ø48	Ø50	Ø55
30	50	58	66	71	79													
38		81	92	130	103	149	161	202										
42				105	117	168	131	164	189	215	257							
45					230	332	230	288	331	376	451	531	589					
55 ⁴⁾							483	606	696	792	585	690	764	843	967	1101	1194	1445

Ordering example:	TOOLFLEX® 38 S-KN	6.5 - Ø15	6.5 - Ø22
	Size and type of coupling	Finish bore	Finish bore

TOOLFLEX® S-KN

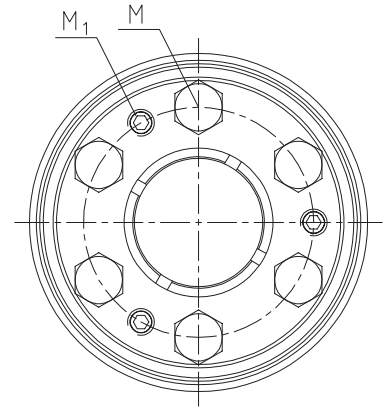
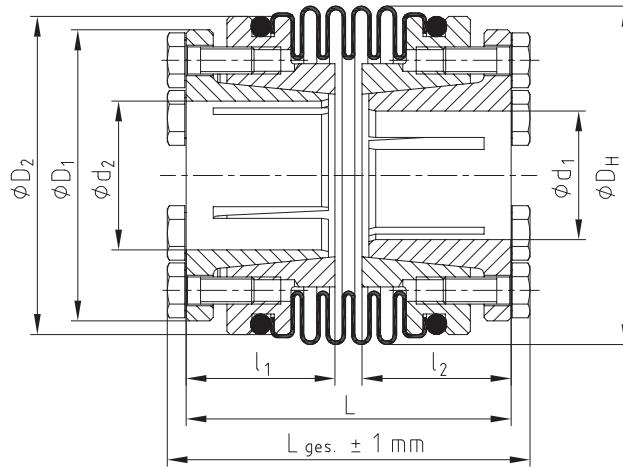

TOOLFLEX® M-KN

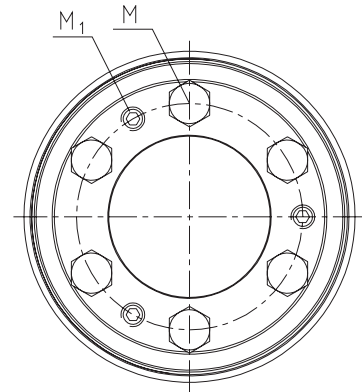
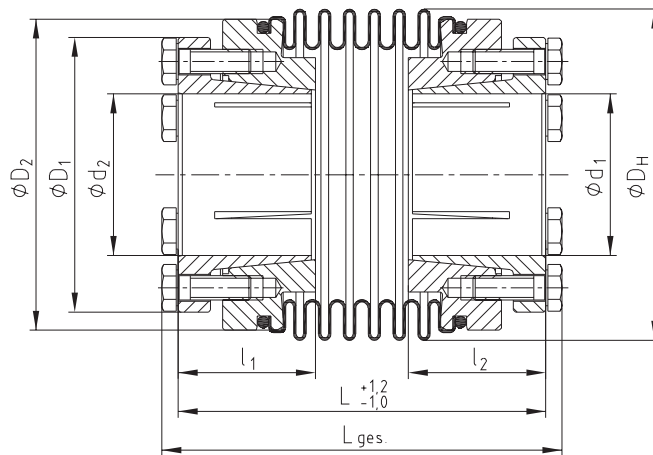

Other types:

TOOLFLEX® KN for FANUC motors

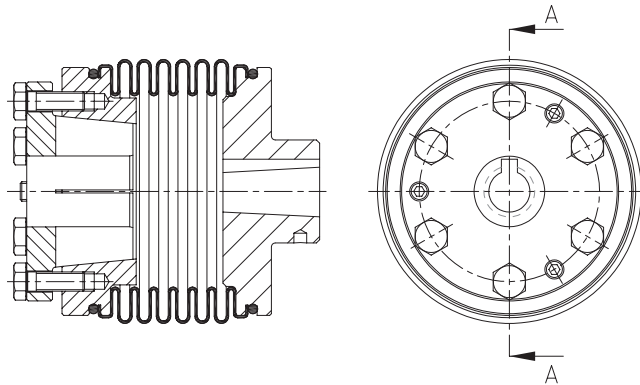

Types of hubs

Type 6.5

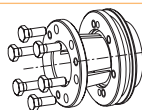

Taper hub KN

TOOLFLEX® PI

Metal bellow-type couplings

Axial plug-in



For legend of pictogram please refer to flapper on the cover

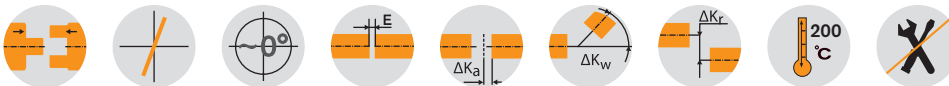

TOOLFLEX® Type S-PI - Hub material aluminium/bellow material stainless steel

Size	Type	Dimensions [mm]													
		General										Clamping screw			
		Min. d ₁ , d ₂	Max. d ₁	Max. d ₂	L ¹⁾	l ₁	l ₂	E	D _H	H	M ₁ , M ₂	D ₃	e	t ₁ , t ₂	T _A [Nm]
20	S	8	20	20	67.0	21.5	33.5	12.0	40	0.5 - 1	M5	43.5	14.5	6	6
30	S	10	30	28	73.5	23.0	33.5	17.0	55	0.5 - 1	M6	58.0	19.0	7	10
38	S	12	38	32	87.5	25.5	44.0	18.0	65	0.5 - 1.5	M8	72.6	25.0	9	25
42	S	14	42	35	93.0	30	39.0	21.0	70	0.5 - 1.5	M8	76.1	25.0	9	25
45	S	14	45	42	96.0	32.0	41.5	22.5	83	0.5 - 1.5	M10	89.0	30.0	11	49
55 ⁴⁾	S	20	55	55	130.0	40	58.5	31.5	100	0.5 - 1.5	M12	106.0	37	14	120

Technical data TOOLFLEX® S-PI

Size	Type	Torque of bellow T _{KN} ²⁾ [Nm]	Max. speed [rpm]	Moment of inertia ³⁾ [x10 ⁻⁶ kgm ²]	Torsion spring stiffness C _T [Nm/rad]	Axial stiffness C _A [N/mm]	Radial stiffness C _R [N/mm]	Perm. displacements		Weight ³⁾ [kg]
								Radial [mm]	Angular [degree]	
20	S	15	11950	37	6600	63	189	0.15	1.0	0.15
30	S	35	8700	140	11500	97	233	0.20	1.5	0.29
38	S	65	7350	329	21500	108	318	0.20	1.5	0.50
42	S	95	6820	396	31500	120	499	0.20	1.5	0.49
45	S	170	5750	1031	55000	132	738	0.25	1.5	0.93
55 ⁴⁾	S	340	4800	6150	144100	160	894	0.25	1.5	3.80

TOOLFLEX® Type M-PI - Hub material aluminium/bellow material stainless steel

Size	Type	Dimensions [mm]													
		General										Clamping screw			
		Min. d ₁ , d ₂	Max. d ₁	Max. d ₂	L ¹⁾	l ₁	l ₂	E	D _H	H	M ₁ , M ₂	D ₃	e	t ₁ , t ₂	T _A [Nm]
20	M	8	20	20	74.0	21.5	33.5	19.0	40	0.5 - 1	M5	43.5	14.5	6	6
30	M	10	30	28	82.5	23.0	33.5	26.0	55	0.5 - 1	M6	58.0	19.0	7	10
38	M	12	38	32	99.5	25.5	44.0	30.0	65	0.5 - 1.5	M8	72.6	25.0	9	25
42	M	14	42	35	104.0	30	39.0	32.0	70	0.5 - 1.5	M8	76.1	25.0	9	25
45	M	14	45	42	112.5	32.0	41.5	39.0	83	0.5 - 1.5	M10	89.0	30.0	11	49
55	M	20	55	55	143.5	40	58.5	45	100	0.5 - 1.5	M12	106.0	37	14	120

Technical data TOOLFLEX® M-PI

Size	Type	Torque of bellow T _{KN} ²⁾ [Nm]	Max. speed [rpm]	Moment of inertia ³⁾ [x10 ⁻⁶ kgm ²]	Torsion spring stiffness C _T [Nm/rad]	Axial stiffness C _A [N/mm]	Radial stiffness C _R [N/mm]	Perm. displacements		Weight ³⁾ [kg]
								Radial [mm]	Angular [degree]	
20	M	15	11950	38	4900	42	126	0.20	1.5	0.16
30	M	35	8700	145	10200	65	155	0.25	2.0	0.31
38	M	65	7350	346	15100	72	212	0.25	2.0	0.52
42	M	95	6820	427	22000	80	333	0.25	2.0	0.52
45	M	170	5750	1127	41000	88	492	0.30	2.0	1.00
55 ⁴⁾	M	340	4800	6270	96100	107	598	0.30	2.0	3.90

¹⁾ When being plugged in

²⁾ For selection see page 22 et seqq.

³⁾ Figures refer to the complete coupling with max. bore.

⁴⁾ Hub made of steel welded with bellow.

Review of shaft-hub-connection: Friction torques T_R [Nm] for hub design 2.5 for Ød₁/Ød₂

Size	Ø8	Ø9	Ø10	Ø11	Ø12	Ø14	Ø15	Ø16	Ø18	Ø19	Ø20	Ø24	Ø25	Ø28	Ø30	Ø32	Ø35	Ø38	Ø40	Ø42	
20	17.6	18.1	18.6	19.1	19.5	20.5	21.0	21.4	22.4	22.9	23.3										
30				33.1	33.8	35.1	35.8	36.5	37.8	38.5	39.2	41.9	42.5	44.6	45.9						
38					79.2	80.4	81.7	84.2	85.4	86.6	91.6	92.8	96.5	99.0	102						
42					79.2	80.4	81.7	84.2	85.4	86.6	91.6	92.8	96.5	99.0	102	105					
45										157	165	167	173	177	181	187	193	197	200		
55												397	401	413	421	429	442	454	462	470	

Ordering
example:

TOOLFLEX® 30 S-PI	d ₁ - Ø22	d ₂ - Ø18
Size and type of coupling	Finish bore	Finish bore

TOOLFLEX® S-PI

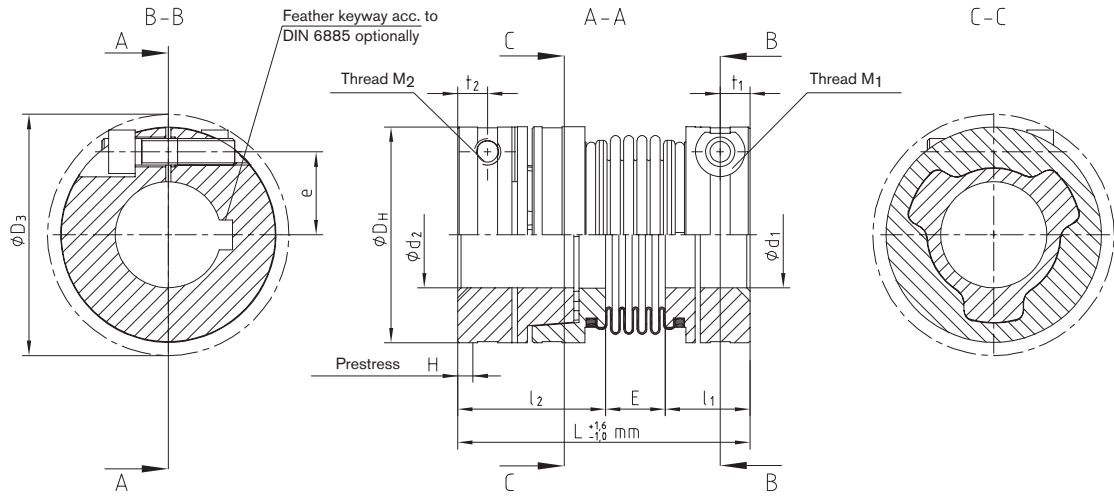

TOOLFLEX® M-PI

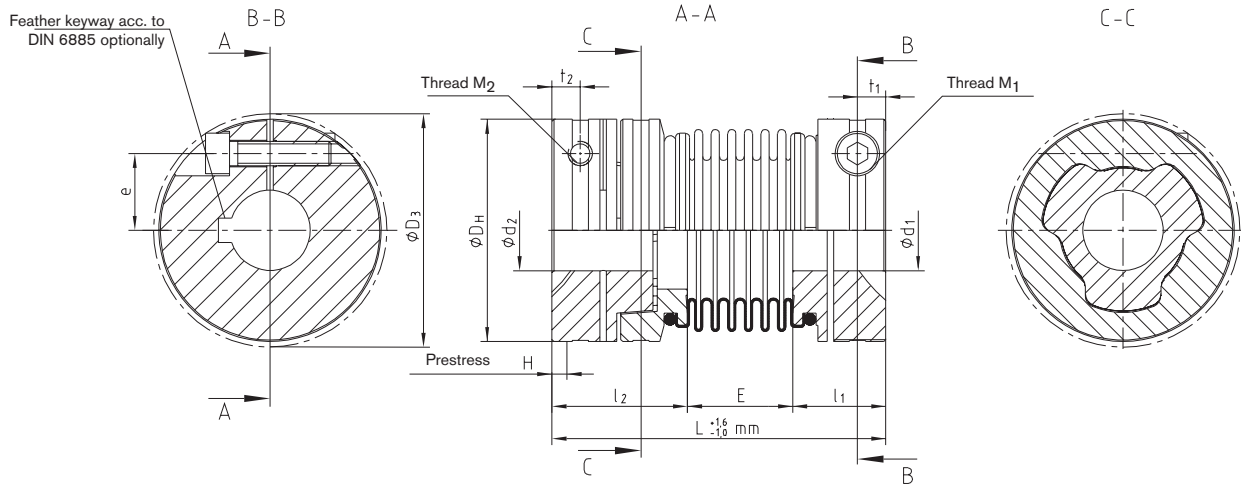

ROTEX® GS

TOOLFLEX®

RADEX®-NC

COUNTEX®

Backlash-free
servo couplings

TOOLFLEX® CF

Metal bellow-type couplings

Flange programme



For legend of pictogram please refer to flapper on the cover

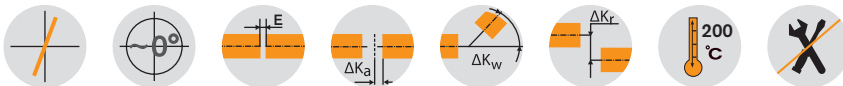

TOOLFLEX® Type S-CF - Hub material aluminium (size 55 steel)/bellow material stainless steel																		
Size	Finish bore d		Dimensions [mm]									Clamping screw				Flange		
	Min.	Max.	D _H	D _B	D _F	d ₂ H7	l ₃	l ₁	l ₂	E	L	D _K	e ₁	t ₁	M	T _A	D _T	M ₁
30	10	30	55	50	47	25	1.5	16	23.0	10.5	49.5	58.0	19	7	M6	10	30	M4
						29											34	
38	12	38	65	60.5	55.75	29	1.5	18	25.5	11.0	54.5	72.6	25	9	M8	25	35	M5
						36											42	
42	14	42	70	66	62.95	36	1.5	21	30.0	15.0	66.0	76.1	27	9	M8	25	42	M5
						43											49	
45	14	45	83	82	77	38	1.5	23	32.0	14.5	69.5	89.0	30	11	M10	49	45	M6
						49											56	
55 ²⁾	20	55	100	97	95	51	1.5	28	40.0	23.5	91.5	106.0	37	14	M12	120	60	M8
						68											78	

Technical data									
Size	Type	Torque of bellow T _{KN} ¹⁾ [Nm]	Max. speed [rpm]	Torsion spring stiff- ness C _T [Nm/rad]	Axial stiffness C _A [N/mm]	Radial stiffness C _R [N/mm]	Perm. displacements		
							Axial [mm]	Radial [mm]	Angular [degree]
30	S	35	8700	14800	97	233	±0.5	0.20	1.5
38	S	65	7350	24900	108	318	±0.6	0.20	1.5
42	S	95	6820	36500	120	499	±0.6	0.20	1.5
45	S	170	5750	64000	132	738	±0.9	0.25	1.5
55 ²⁾	S	340	4800	96100	160	894	±1.0	0.25	1.5

TOOLFLEX® Type M-CF - Hub material aluminium (size 55 steel)/bellow material stainless steel																		
Size	Finish bore		Dimensions [mm]									Clamping screw				Flange		
	d ₁ min.	d ₁ max.	D _H	D _B	D _F	d ₂ H7	l ₃	l ₁	l ₂	E	L	D _K	e ₁	t ₁	M	T _A	D _T	M ₁
30	10	30	55	50	47	25	1.5	16	23.0	19.5	58.5	58.0	19	7	M6	10	30	M4
						29											34	
38	12	38	65	60.5	55.75	29	1.5	18	25.5	23.0	66.5	72.6	25	9	M8	25	35	M5
						36											42	
42	14	42	70	66	62.95	36	1.5	21	30.0	26.0	77.0	76.1	27	9	M8	25	42	M5
						43											49	
45	14	45	83	82	77	38	1.5	23	32.0	31.0	86.0	89.0	30	11	M10	49	45	M6
						49											56	
55 ²⁾	20	55	100	97	95	51	1.5	28	40.0	37.0	105.0	106.0	37	14	M12	120	60	M8
						68											78	

Technical data									
Size	Type	Torque of bellow T _{KN} ¹⁾ [Nm]	Max. speed [rpm]	Torsion spring stiff- ness C _T [Nm/rad]	Axial stiffness C _A [N/mm]	Radial stiffness C _R [N/mm]	Perm. displacements		
							Axial [mm]	Radial [mm]	Angular [degree]
30	M	35	8700	14800	65	155	±0.8	0.25	2.0
38	M	65	7350	24900	72	212	±0.8	0.25	2.0
42	M	95	6820	36500	80	333	±0.8	0.25	2.0
45	M	170	5750	64000	88	492	±1.0	0.30	2.0
55 ²⁾	M	340	4800	96100	107	598	±1.0	0.30	2.0

¹⁾ For selection see page 22 et seqq.

²⁾ Hub made of steel welded with bellow.

Review of shaft-hub-connection: Friction torques T _R [Nm] for hub design 2.5																						
Size	Ø10	Ø11	Ø12	Ø14	Ø15	Ø16	Ø18	Ø19	Ø20	Ø24	Ø25	Ø28	Ø30	Ø32	Ø35	Ø38	Ø40	Ø42	Ø45	Ø50	Ø55	
30		33.1	33.8	35.1	35.8	36.5	37.8	38.5	39.2	41.9	42.5	44.6	45.9									
38							84.2	85.4	86.6	91.6	92.8	96.5	99.0	102	105	109						
42				84.2	85.4	86.6	89.1	90.3	91.6	96.5	97.8	102	104	106	110	114	116	119				
45								157	165	167	173	177	181	187	193	197	200	206				
55 ⁴⁾									397	401	413	421	429	442	454	462	470	482	502	523		

Ordering example:	TOOLFLEX® 38 M-CF	Ø15	Ø29 - Ø35 - 6xM5
	Size and type of coupling	Finish bore	Dimensions flange (d ₂ - D _T - M ₁)

TOOLFLEX® S-CF

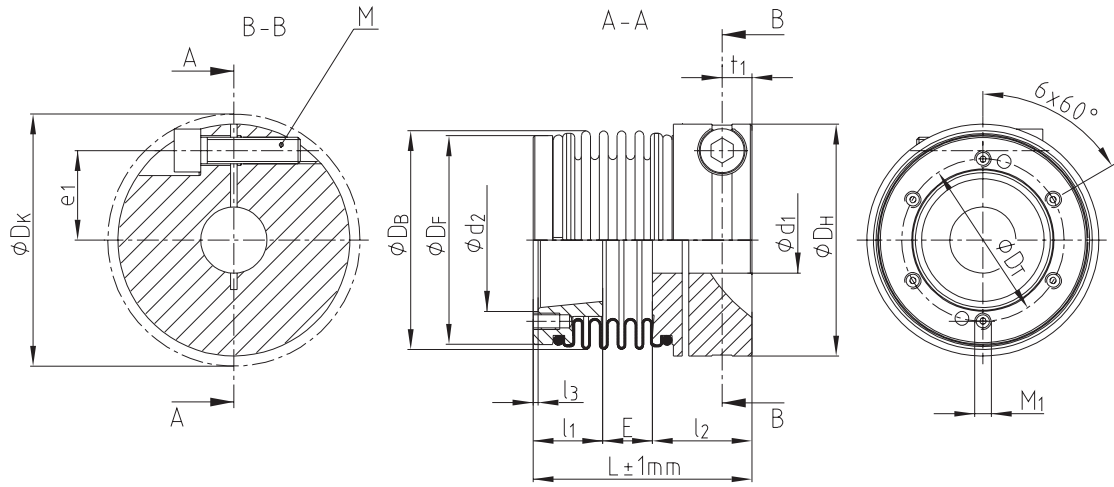

TOOLFLEX® M-CF

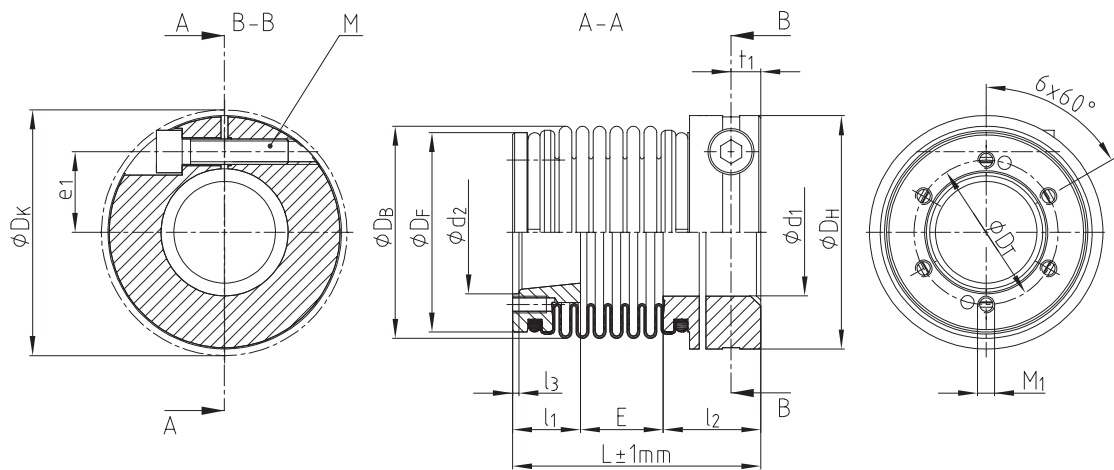

ROTEX® GS

TOOLFLEX®

Backlash-free
servo couplings

RADEX®-NC

COUNTEX®

TOOLFLEX® S-H / M-H

Metal bellow-type couplings

Shell clamping hubs

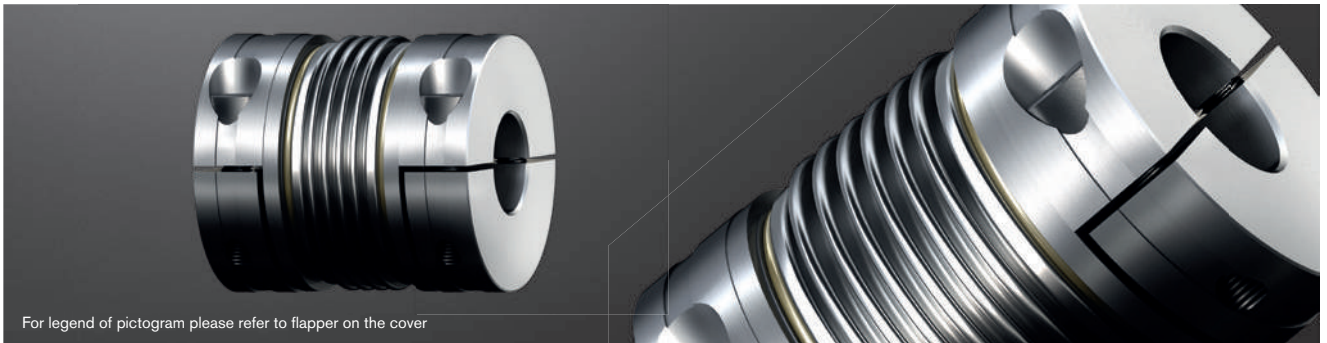

For legend of pictogram please refer to flapper on the cover

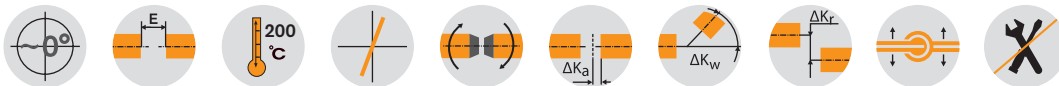

TOOLFLEX® type S-H / shell clamping hubs - Hub material aluminium/bellow material stainless steel

Size	Finish bore d		Dimensions [mm]												
	Min.	Max.	General								Clamping screws DIN EN ISO 4762				
			L	l _{1, 2}	E	D _H	D _K	E ₁	t ₁	x _{1/x2}	e	M	T _A [Nm]		
20	8	20	51	19.5	12.0	40	41.2	26.0	5.5	12.5	14.5	M4	5.0		
30	10	28	68	25.5	17.0	55	57.7	34.0	7.5	17.0	19.0	M6	15.0		
38	12	38	78	30.0	18.0	65	72.6	36.0	9.5	21.0	25.0	M8	40.0		
45	14	45	94.5	36.0	22.5	83	88.8	46.5	11.0	24.0	30.0	M10	70.0		

Technical data TOOLFLEX® S-H

Size	Bellow-hub-connection	Torque of bellow T _{KN} ¹⁾ [Nm]	Max. speed [rpm]	Moment of inertia ²⁾ [x10 ⁻⁶ kgm ²]	Torsion spring stiffness C _T [Nm/rad]	Axial stiffness C _A [N/mm]	Radial stiffness C _R [N/mm]	Perm. displacements			Weight ²⁾ [kg]
								Axial [mm]	Radial [mm]	Angular [degree]	
20	Flanged	15	9550	28	9600	63	189	±0.4	0.15	1.0	0.110
30		35	6950	20	17800	97	233	±0.5	0.20	1.5	0.285
38		65	5850	42	37400	108	318	±0.6	0.20	1.5	0.422
45		170	4750	1003	95800	132	738	±0.9	0.20	1.5	0.897

TOOLFLEX® type M-H / shell clamping hubs - Hub material aluminium/bellow material stainless steel

Size	Finish bore d		Dimensions [mm]												
	Min.	Max.	General								Clamping screws DIN EN ISO 4762				
			L	l _{1, 2}	E	D _H	D _K	E ₁	t ₁	x _{1/x2}	e	M	T _A [Nm]		
20	8	20	58	19.5	19.0	40	41.2	33.0	5.5	12.5	14.5	M4	5.0		
30	10	30	77	25.5	26.0	55	57.7	43.0	7.5	17.0	19.0	M6	15.0		
38	12	38	90	30.0	30.0	65	72.6	48.0	9.5	21.0	25.0	M8	40.0		
45	14	45	111	36.0	39.0	83	88.8	63.0	11.0	24.0	30.0	M10	70.0		

Technical data TOOLFLEX® M-H

Size	Bellow-hub-connection	Torque of bellow T _{KN} ¹⁾ [Nm]	Max. speed [rpm]	Moment of inertia ²⁾ [x10 ⁻⁶ kgm ²]	Torsion spring stiffness C _T [Nm/rad]	Axial stiffness C _A [N/mm]	Radial stiffness C _R [N/mm]	Perm. displacements			Weight ²⁾ [kg]
								Axial [mm]	Radial [mm]	Angular [degree]	
20	Flanged	15	9550	29	9600	63	189	±0.4	0.15	1.0	0.115
30		35	6950	138	17800	97	233	±0.5	0.20	1.5	0.304
38		65	5850	310	37400	108	318	±0.6	0.20	1.5	0.445
45		170	4750	1069	95800	132	738	±0.9	0.25	1.5	0.947

¹⁾ For selection see page 22 et seqq.

²⁾ Figures refer to the complete coupling with max. bore.

To make sure that the coupling can be assembled/disassembled radially, please observe the insertion dimension x_{1/x2} of the shafts.

Review of shaft-hub-connection: Friction torques T_R [Nm] for hub design 2.5 for Ød₁/Ød₂

Size	Ø8	Ø9	Ø10	Ø11	Ø12	Ø14	Ø15	Ø16	Ø18	Ø19	Ø20	Ø24	Ø25	Ø28	Ø30	Ø32	Ø35	Ø38	Ø40	Ø42	Ø45	
20	12.5	14.1	15.7	17.2	18.8	21.9	23.5	25.1	28.2	29.8	31.3											
30			31.8	35.0	38.2	44.5	47.7	50.9	57.3	60.4	63.6	76.3	79.5	89.1								
38					74.9	87.4	93.7	99.9	112.4	118.6	124.9	149.9	156.1	174.8	187.3	199.8	218.5	237.3				
45						123.4	132.2	141.0	158.6	167.4	176.2	211.5	220.3	246.7	264.4	282.0	308.4	334.9	352.5	370.1	396.5	

Ordering example:

TOOLFLEX® 30 S-H	7.8 - Ø25			7.9 - Ø30		
Size and type of coupling	Hub design	Finish bore		Hub design	Finish bore	

TOOLFLEX® S-H

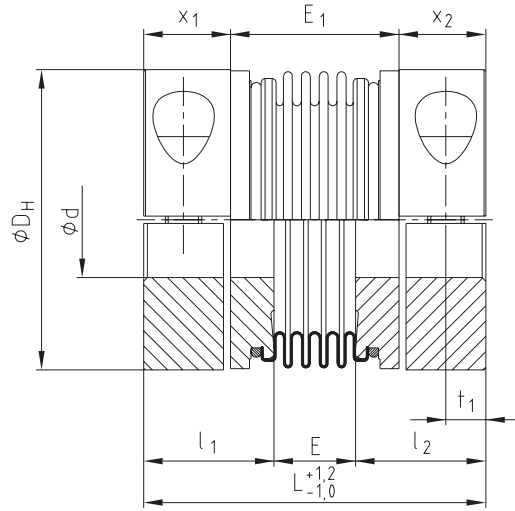
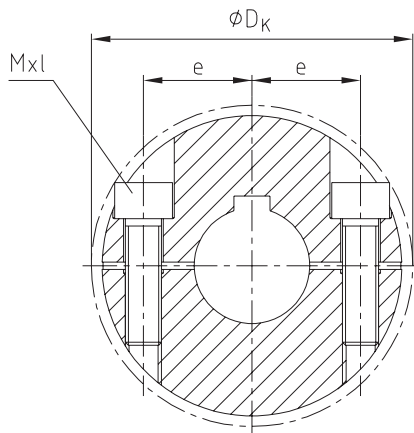

TOOLFLEX® M-H

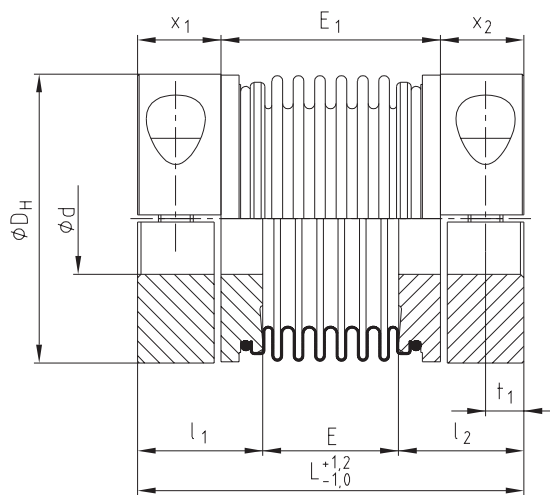
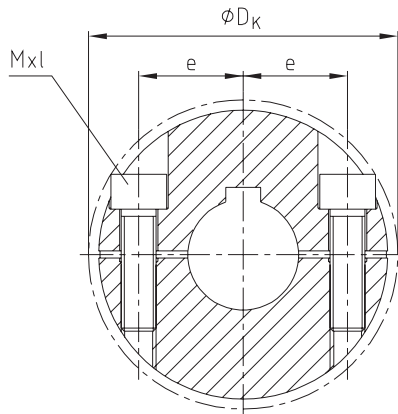

Types of hubs

Type 7.8



clamping hub type H without feather keyway for single-cardanic connection

Type 7.9



clamping hub type H with feather keyway for single-cardanic connection (on request)

ROTEX® GS

TOOLFLEX®

RADEX®-NC

COUNTEX®

Backlash-free
servo couplings

TOOLFLEX® ZR

Metal bellow-type couplings

Intermediate shaft coupling with aluminium pipe bonded

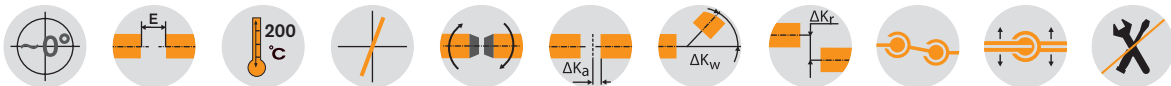
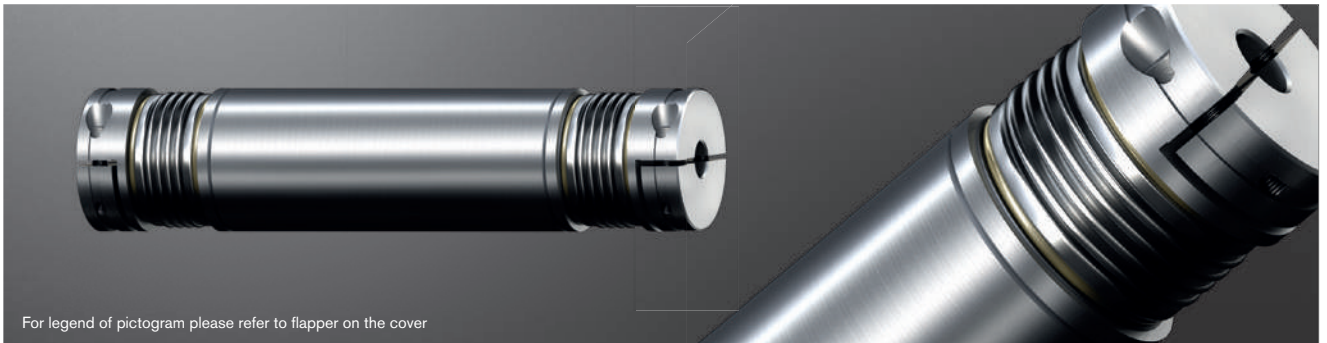

TOOLFLEX® type ZR / shell clamping hubs - Hub material aluminium/bellow material stainless steel

Size	Finish bore d		Dimensions [mm]											Clamping screws DIN EN ISO 4762	
	Min.	Max.	D _H	L	l ₃	L _R		L _{ZR} = L _R + 2 • l ₃		d _R	D _K	t ₁	e	M	T _A [Nm]
						Min.	Max.	Min.	Max.						
20	8	20	40	40	12.5	80	2975	105	3000	40	41.2	5.5	14.5	M4	5
30	10	28	55	58.5	17.0	114	3466	148	3500	50	58.0	7.5	19	M6	15
38	12	38	65	61	21.0	129	3958	171	4000	60	72.6	9.5	25	M8	40
45	14	45	83	78.5	25.0	149	3950	199	4000	80	89.0	11.0	30	M10	70

Technical data TOOLFLEX® ZR

Size	Torque of bellow T _{KN} ¹⁾ [Nm]	Moment of inertia [10 ⁻³ kgm ²]		Static torsion spring stiffness [Nm/rad]
		Z _R hub ²⁾	Pipe/meter	
20	15	0.024378	0.329	1935
30	35	0.121256	0.673	3800
38	65	0.253162	1.199	7240
45	170	0.961451	4.560	23183

¹⁾ For selection see page 22 et seqq.

²⁾ Figures refer to the max. bore

³⁾ Torsion spring stiffness with a length of 1 m of intermediate pipe with L_{pipe} = L_{ZR} - 2 • L

For inquiries and orders please specify the shaft distance dimension L_R along with the maximum speed to review the critical bending speed. Straightness/concentricity of pipes according to DIN EN 755-1.

Review of shaft-hub-connection: Friction torques T_R [Nm] for hub design 7.5 for Ød₁/Ød₂

Size	Ø8	Ø9	Ø10	Ø11	Ø12	Ø14	Ø15	Ø16	Ø18	Ø19	Ø20	Ø24	Ø25	Ø28	Ø30	Ø32	Ø35	Ø38	Ø40	Ø42	Ø45		
20	12.5	14.1	15.7	17.2	18.8	21.9	23.5	25.1	28.2	29.8	31.3												
30			31.8	35.0	38.2	44.5	47.7	50.9	57.3	60.4	63.6	76.3	79.5	89.1									
38					74.9	87.4	93.7	99.9	112.4	118.6	124.9	149.9	156.1	174.8	187.3	199.8	218.5	237.3					
45						123.4	132.2	141.0	158.6	167.4	176.2	211.5	220.3	246.7	264.4	282.0	308.4	334.9	352.5	370.1	396.5		

Ordering example:

TOOLFLEX® 30	ZR	1200 mm	7.5 - Ø24		7.6 - Ø24	
Size and type of coupling	Type	Shaft distance dimension (L _R)	Hub design	Finish bore	Hub design	Finish bore

TOOLFLEX® ZR

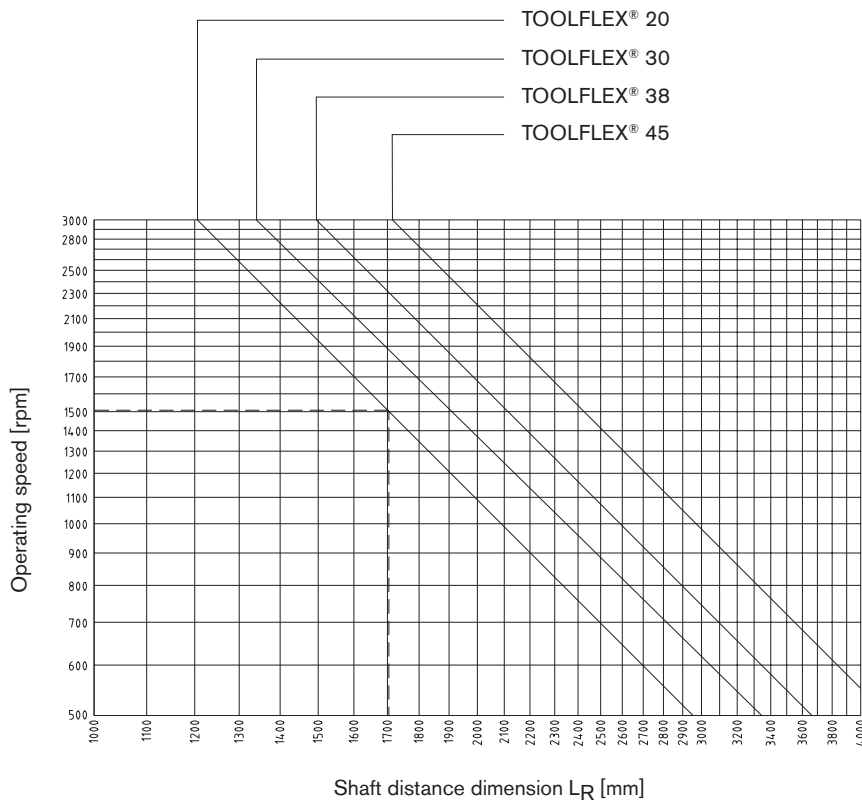
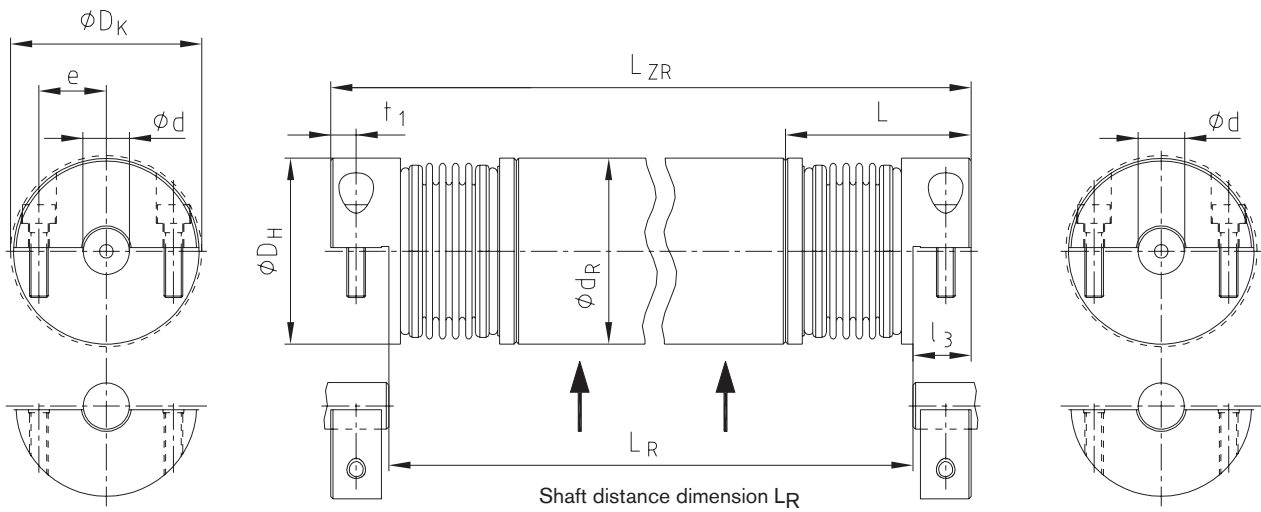

Types of hubs

Type 7.5

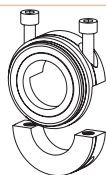

Clamping hub type DH without feather keyway for double-cardanic connection

Type 7.6

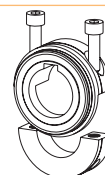

Clamping hub type DH with feather keyway for double-cardanic connection (on request)

RADEX®-NC

Servo lamina couplings

Technical description

RADEX®-NC is a line specifically developed for servo technology. With this coupling a set of torsionally rigid steel laminas yet soft in bending ensure a reliable compensation for axial, angular and radial shaft displacements. As an all-metal coupling - the laminas are made of stainless steel - RADEX®-NC can even be used with high temperatures (up to 200 °C) and under aggressive ambient conditions. RADEX®-NC is manufactured in 14 sizes from size 5 to 61 for max. torques up to 3000 Nm. In addition to the two different types (EK = single-cardanic and DK = double-cardanic) it is available in five different types of hubs.



A typical application of RADEX®-NC are backlash-free worm gear pairs with low gear ratios. For reason of the gear ratio of the gearbox the rigidity of the coupling must be converted from the drive side into the driven side. Here the gear ratio itself has a decisive influence because it is squarely included in the calculation. This converted rigidity is added in line with the gearbox stiffness in order to get the total rigidity. For gear ratios that are smaller than $i = 8$ we recommend to use RADEX®-NC due to the loss of rigidity of the total system arising with the use of flexible couplings.

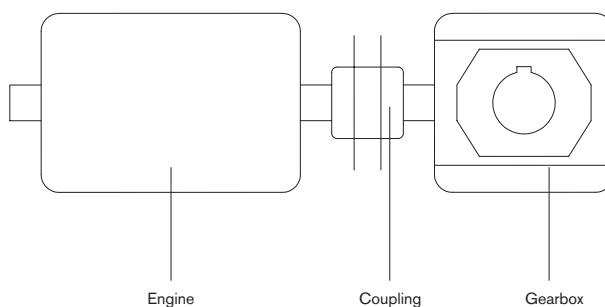

Use in potentially explosive atmospheres

RADEX®-NC couplings are suitable for power transmission in drives in potentially explosive atmospheres. The couplings are assessed and approved according to EU directive 2014/34/EU as units of category 2G/2D and thus suitable for the use in potentially explosive atmospheres of zone 1, 2, 21 and 22. Please read through our information included in the respective Type Examination Certificate and the operating and assembly instructions at www.ktr.com.

Selection:

If used in potentially explosive atmospheres, the clamping hubs without feather keyway only for use in category 3 (with feather keyway for cat. 2) must be selected such that there is a minimum safety factor of $s = 2$ between the peak torque (including all operating parameters) and the nominal torque and frictional torque of engagement of the coupling.



Types of hubs



Type 2.5 clamping hub
double slotted, without feather keyway
Frictionally engaged, backlash-free shaft-hub-connection. Transmittable torques depending on bore diameter.



Type 2.6 clamping hub
double slotted, with feather keyway
Positive-locking power transmission with additional friction fit. The friction fit avoids or reduces reverse backlash. Surface pressure of the keyway connection is reduced.



Type 6.5 clamping ring hub
Integrated frictionally engaged shaft-hub-connection for the transmission of higher torques. Suitable for high speeds.



Type 3.5 clamping hub
triple slotted, without feather keyway
Frictionally engaged, backlash-free shaft-hub-connection, good properties of concentric running and reduced imbalance. Transmittable torques depending on bore diameter. Type 3.5 standard from size 43

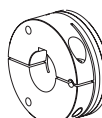

Type 3.6 clamping hub
triple slotted, with feather keyway
Positive-locking power transmission with additional friction fit. The friction fit avoids or reduces reverse backlash. Surface pressure of the keyway connection is reduced. Type 3.6 standard from size 43

RADEX®-NC DK and EK Servo lamina couplings

Double- and single-cardanic types



For legend of pictogram please refer to flapper on the cover

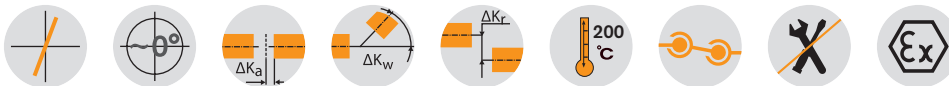

Hub design 2.5/2.6

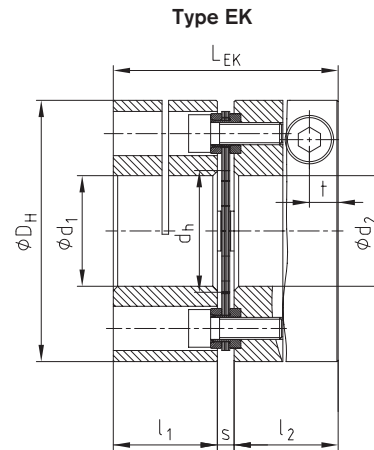
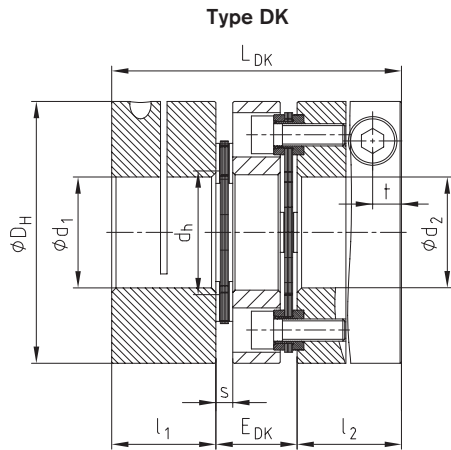

RADEX®-NC Types DK and EK - Hub and spacer material aluminium (size 42 steel)/laminas stainless steel

Size	Dimensions [mm]									Clamping screw		Mass moments of inertia	
	Max. d1, d2	D _H	l ₁ , l ₂	L _{DK}	E _{DK}	L _{EK}	d _h	s	t	M	T _A [Nm]	DK [kgm ²]	EK [kgm ²]
5	12	26	12	34	10	26.5	12	2.5	3.5	M2.5	0.8	0.000004	0.000003
10	15	35	16	44	12	35	14.5	3	5.0	M4	3	0.000016	0.000012
15	20	47	21	55	13	45	19.5	3	6.8	M6	10	0.000065	0.000053
20	25	59	24	67	19	52	24	4	6.5	M6	10	0.000199	0.000154
25	35	70	32	88	24	69	30	5	9.0	M8	25	0.000508	0.000393
35	42	84	35	98	28	77	38	7	10.5	M10	49	0.001153	0.000911
42	55	104	40	116	36	91	48	11	10.5	M10	69	0.007458	0.006153

Technical data

Size	T _{KN} ¹⁾ [Nm]	T _{K max} ¹⁾ [Nm]	Max. speed [rpm]	Torsion spring stiffness [Nm/rad]		Displacements of type DK			Displacements of type EK		
				Type EK	Type DK	Radial [mm]	Axial [mm]	Angular each lamina [°]	Radial [mm]	Axial [mm]	Angular each lamina [°]
5	2.5	5	18300	2400	1200	0.10	0.4	1	—	0.2	1
10	7.5	15	13600	5600	2800	0.14	0.8	1	—	0.4	1
15	20	40	10100	12000	6000	0.16	1.0	1	—	0.5	1
20	30	60	8050	30000	15000	0.25	1.2	1	—	0.6	1
25	60	120	6800	60000	30000	0.30	1.6	1	—	0.8	1
35	100	200	5650	72000	36000	0.40	2.0	1	—	1.0	1
42	300	600	4550	240000	120000	0.50	2.8	1	—	1.4	1

¹⁾ For selection see page 22 et seqq.

Review of shaft-hub-connection: Friction torques T_R [Nm] for hub design 2.5

Size	Pilot bored	Ø3	Ø5	Ø8	Ø10	Ø12	Ø14	Ø15	Ø16	Ø19	Ø20	Ø24	Ø25	Ø28	Ø30	Ø32	Ø35	Ø38	Ø40	Ø45	Ø50	Ø55
5	2.5	2.2	2.3	2.4	2.5																	
10	4.5		8	9	10	10	11	11														
15	5.5				28	30	31	32	32	34	35											
20	7.5					36	37	38	39	40	41	44	45									
25	9.5							82	83	87	88	93	94	98	100	103	106					
35	11.5									155	157	165	167	173	177	181	187	193	197			
42	15.0											285	287	296	301	307	315	323	329	343	357	370

Ordering example:

RADEX®-NC 20	DK	2.5 - Ø20		2.5 - Ø25	
Coupling size	Type	Hub design	Finish bore	Hub design	Finish bore

RADEX®-NC High-Torque DK and EK Servo lamina couplings

Double- and single-cardanic types

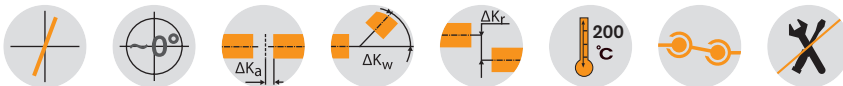
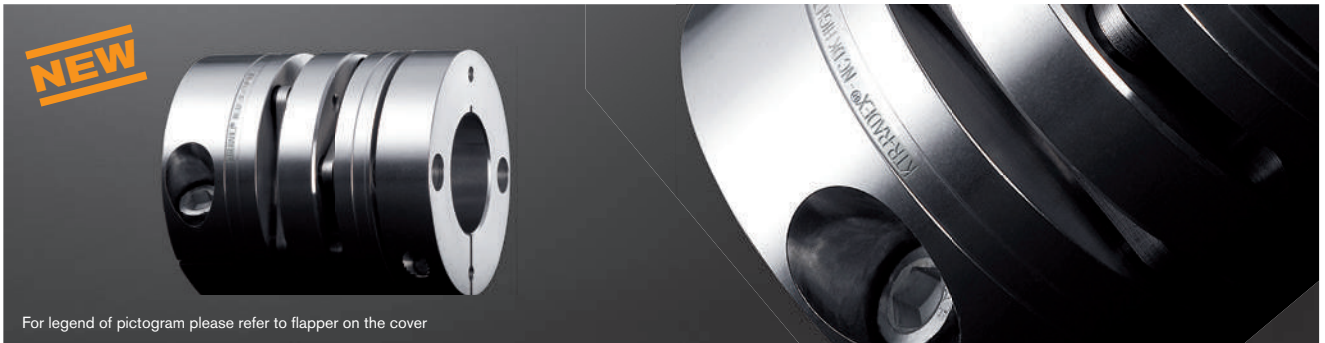

Hub design 2.5/2.6

Type DK

Type EK

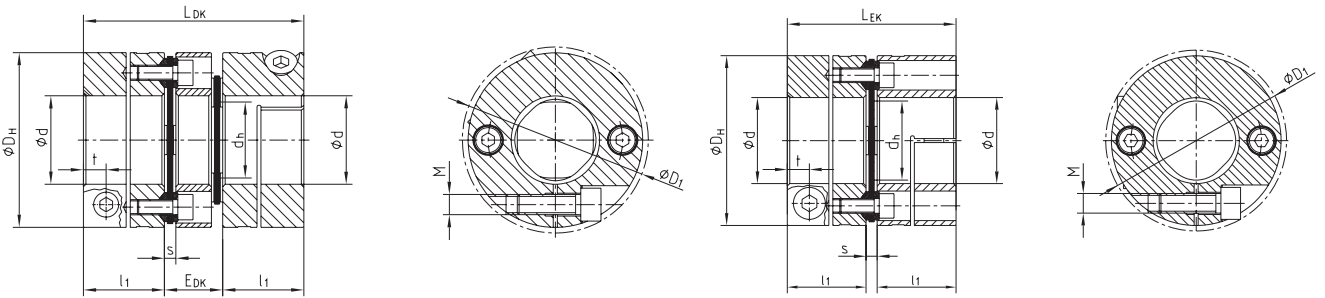

RADEX®-NC HT Types DK and EK - Hub and spacer material aluminium/laminas stainless steel

Size	Dimensions [mm]										Clamping screw		Mass moments of inertia	
	Max. d1, d2	DH	D1	l1, l2	LDK	EDK	LEK	d _h	s	t	M	T _A [Nm]	DK [kgm ²]	EK [kgm ²]
16	20	46	48.9	22	58	14	47	19.5	3	6.8	M6	10	0.000063	0.00005
21	30	58	59.2	25	69	19	53.5	24	3.5	6.8	M6	10	0.00018	0.00014
26	38	69	73.4	32	88	24	69	30	5	9	M8	25	0.00046	0.00036
36	45	84	86.8	35	93.6	23.6	74.8	48	4.8	10.5	M10	49	0.0011	0.00091

Technical data

Size	T _{KN} ¹⁾ [Nm]	T _{K max} ¹⁾ [Nm]	Max. speed [rpm]	Torsion spring stiffness [Nm/rad]		Lamina shape	Displacements of type DK			Displacements of type EK		
				Type EK	Type DK		Radial [mm]	Axial [mm]	Angular each lamina [degree]	Radial [mm]	Axial [mm]	Angular each lamina [degree]
16	35	53	10,500	20,000	10,000	4 holes	0.16	1.00	1	—	0.50	1
21	70	105	8,500	40,000	20,000	4 holes	0.25	1.20	1	—	0.60	1
26	120	180	7,000	63,000	31,500	4 holes	0.30	1.60	1	—	0.80	1
36	340	510	5,700	250,000	125,000	6 holes	0.40	2.00	1	—	1.00	1

¹⁾ For selection see page 22 et seqq.

Review of shaft-hub-connection: Friction torques T_R [Nm] for hub design 2.5

Size	Pilot bored	Ø10	Ø12	Ø14	Ø15	Ø16	Ø19	Ø20	Ø24	Ø25	Ø28	Ø30	Ø32	Ø35	Ø38	Ø40	Ø42	Ø45
16	5.5	28	30	31	32	32	34	35										
21	7.5		36	37	38	38	41	41	44	45	47	48						
26	9.5				82	83	87	88	93	94	98	100	103	106	110			
36	11.5						156	158	166	168	174	178	181	187	193	197	200	206

Types of hubs



Type 2.5 clamping hub
double slot without feather keyway



Type 2.6 clamping hub
double slot with feather keyway

Ordering example:

RADEX®-NC 21 HT	DK	2.5 - Ø20		2.5 - Ø25	
Coupling size	Type	Hub design	Finish bore	Hub design	Finish bore

RADEX®-NC High-Torque DK and EK Servo lamina couplings

Double- and single-cardanic types

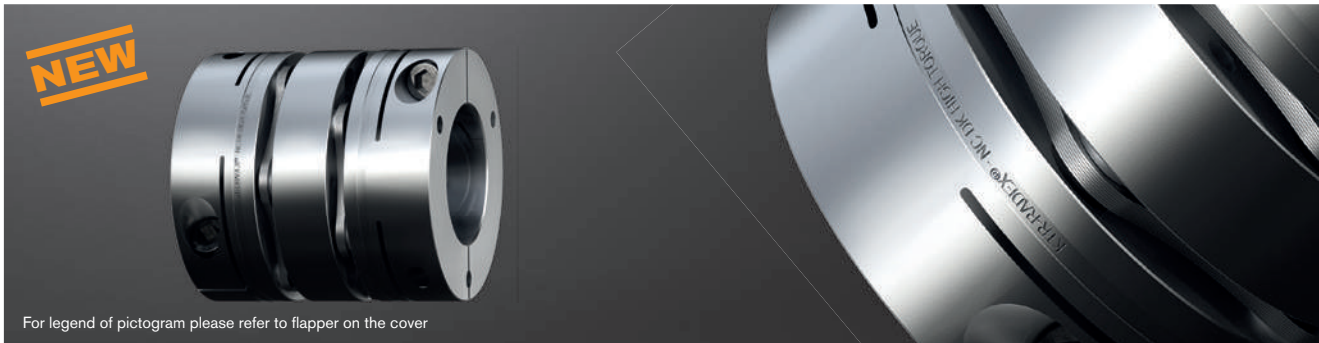

For legend of pictogram please refer to flapper on the cover

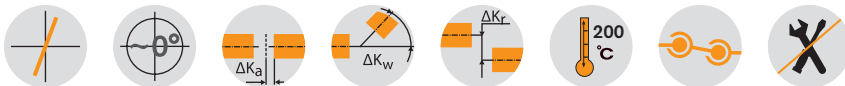

Hub design 3.5/3.6

Type DK

Type EK

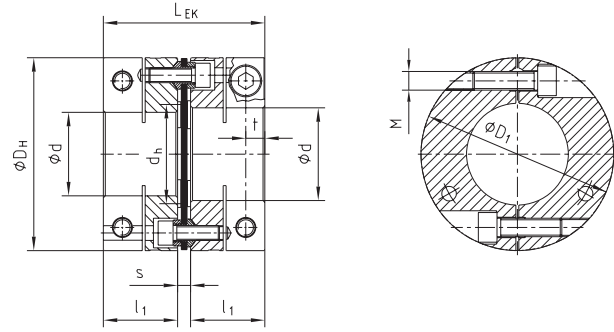
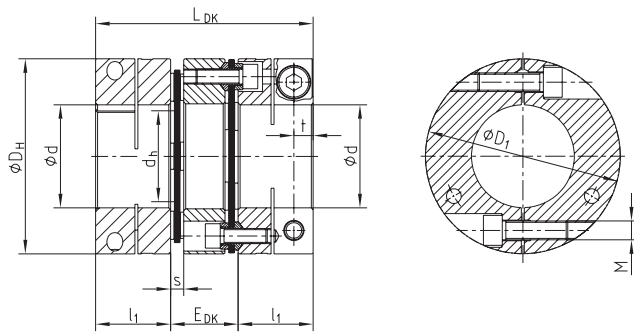

RADEX®-NC HT Types DK and EK - Hub and spacer material aluminium/laminas stainless steel

Size	Dimensions [mm]										Clamping screw		Mass moments of inertia	
	Max. d1, d2	DH	D1	l1, l2	L _{DK}	EDK	LEK	d _h	s	t	M	T _A [Nm]	DK [kgm ²]	EK [kgm ²]
43	55	104	104	40.5	115	34	89	61	8	10.5	M10	49	0.0033	0.0025
51	70	124	126.2	50	138	38	108	73	8	14	M14	135	0.0082	0.006
61	80	144	148.5	54	150	42	118	88	10	16	M16	210	0.016	0.012

Technical data

Size	T _{KN} ¹⁾ [Nm]	T _{K max} ¹⁾ [Nm]	Max. speed [rpm]	Torsion spring stiffness [Nm/rad]		Lamina shape	Displacements of type DK			Displacements of type EK		
				Type EK	Type DK		Radial [mm]	Axial [mm]	Angular each lamina [degree]	Radial [mm]	Axial [mm]	Angular each lamina [degree]
43	600	900	8,100	310,000	155,000	6 holes	0.50	2.20	1	—	1.10	1
51	1,300	1,950	6,700	1,200,000	600,000	6 holes	0.60	2.50	1	—	1.25	1
61	2,000	3,000	6,100	1,550,000	775,000	6 holes	0.73	2.60	1	—	1.30	1

¹⁾ For selection see page 22 et seq.

Review of shaft-hub-connection: Friction torques T_R [Nm] for hub design 3.5

Size	Pilot bored	Ø24	Ø25	Ø28	Ø30	Ø32	Ø35	Ø38	Ø40	Ø42	Ø45	Ø48	Ø50	Ø55	Ø58	Ø60	Ø65	Ø70	Ø75	Ø80
43	15.0	149	155	174	186	198	217	235	248	260	279	297	310	341						
51	28.0		226	253	271	290	317	344	362	380	407	434	452	498	525	543	588	633		
61	30.0										557	594	619	680	717	742	804	866	928	990

Types of hubs

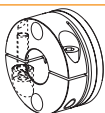

Type 3.5 clamping hub
triple slotted, without feather keyway

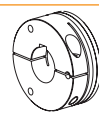

Type 3.6 clamping hub
triple slotted, with feather keyway

Ordering example:

RADEX®-NC 43 HT	DK	3.5 - Ø25		3.5 - Ø35	
Coupling size	Type	Hub design	Finish bore	Hub design	Finish bore

RADEX®-NC High-Torque DK and EK Servo lamina couplings

Double- and single-cardanic types



For legend of pictogram please refer to flapper on the cover

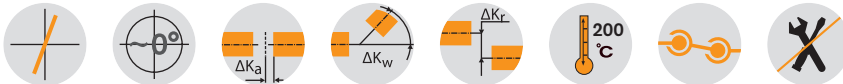

RADEX®-NC HT Types DK and EK - Hub and spacer material aluminium/laminas stainless steel

Size	Dimensions [mm]										Clamping screw		Mass moments of inertia	
	Max. d1, d2	D _H	l ₁ , l ₂	LDK	LDK1	EDK	LEK	LEK1	d _h	s	M	T _A [Nm]	DK [kgm ²]	EK [kgm ²]
16	20	46	24	62	68	14	51	57	19.5	3	M5	6	0.000122	0.000110
21	28	58	28	75	81.2	19	59.5	65.7	24	3.5	M6	10	0.000353	0.000312
26	35	69	36	96	100.8	24	77	81.8	30	5	M8	25	0.000850	0.000747
36	42	84	43	109.6	118.3	23.6	90.8	99.5	48	4.8	M8	25	0.022000	0.002000
43	60	104	46	126	135.9	34	100	109.9	61	8	M8	25	0.005906	0.005133
51	70	124	50	138	150.1	38	108	120.1	73	8	M10	49	0.013597	0.011873
61	80	144	55	152	165.5	42	120	133.5	88	10	M12	85	0.027853	0.024340

Technical data

Size	T _{KN} ¹⁾ [Nm]	T _K max ¹⁾ [Nm]	Max. speed [rpm]	Torsion spring stiffness [Nm/rad]		Lamina shape	Displacements of type DK			Displacements of type EK		
				Type EK	Type DK		Radial [mm]	Axial [mm]	Angular each lamina [degree]	Radial [mm]	Axial [mm]	Angular each lamina [degree]
16	35	53	31,150	20,000	10,000	4 holes	0.16	1.00	1.00	—	0.50	1
21	70	105	24,700	40,000	20,000	4 holes	0.25	1.20	1.00	—	0.60	1
26	120	180	20,800	63,000	31,500	4 holes	0.30	1.60	1.00	—	0.80	1
36	340	510	17,100	250,000	125,000	6 holes	0.40	2.00	1.00	—	1.00	1
43	600	900	13,800	310,000	155,000	6 holes	0.50	2.20	1.00	—	1.10	1
51	1300	1950	11,600	1,200,000	600,000	6 holes	0.60	2.50	1.00	—	1.25	1
61	2000	3000	10,000	1,550,000	775,000	6 holes	0.73	2.60	1.00	—	1.30	1

¹⁾ For selection see page 22 et seqq.

Review of shaft-hub-connection: Friction torques T_R [Nm] for hub design 6.5

Size	Tolerance fit	Ø10	Ø12	Ø15	Ø16	Ø19	Ø20	Ø25	Ø28	Ø30	Ø32	Ø35	Ø38	Ø40	Ø42	Ø45	Ø50	Ø55	Ø60	Ø65	Ø70	Ø75	Ø80
16	H7/h6	29	33	70	50	83	97																
	H7/k6	34	42	76	62	96	109																
21	H7/h6	27	45	91	79	125	145	144	201														
	H7/k6	36	56	99	93	139	157	187	245														
26	H7/h6			104	126	194	169	311	338	404	273	357											
	H7/k6			124	145	214	200	334	382	444	355	441											
36	H7/h6						241	438	521	616	523	664	647	741	841								
	H7/k6						284	471	558	646	640	779	778	875	974								
43	H7/h6								543	705	647	814	946	1073	980	1163	1200	1171	1471				
	H7/k6								634	789	784	916	1096	1219	1144	1332	1376	1380	1679				
51	H7/h6									750	818	1020	1085	1228	1166	1377	1450	1725	2318	2364	2792		
	H7/k6									822	927	1117	1254	1392	1348	1568	1652	1972	2391	2451	2845		
61	H7/h6											880	1074	1211	1264	1480	1750	1952	2145	2573	2707	2764	3196
	H7/k6											951	1131	1258	1333	1534	1810	2036	2244	2638	2788	2860	3254

Ordering example:

RADEX®-NC 26 HT	DK	6.5 - Ø24		6.5 - Ø35	
Coupling size	Type	Hub design	Finish bore	Hub design	Finish bore

Hub design 6.5

Type DK

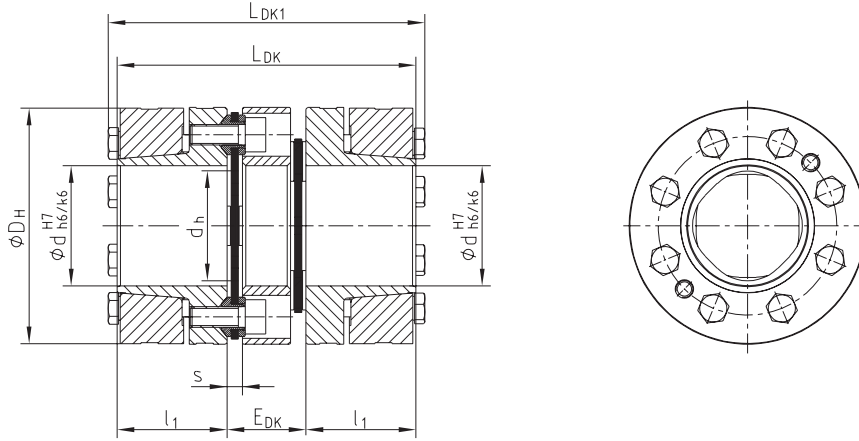

Type EK

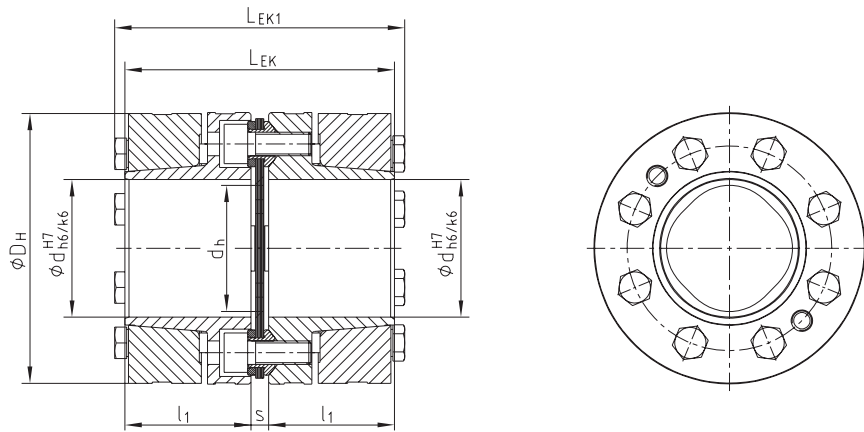

ROTEX® GS

Backlash-free
servo couplings

TOOLFLEX®

RADEX®-NC

COUNTEX®

Types of hubs



Type 6.5
Clamping ring hub

COUNTEX®

Backlash-free shaft encoder couplings

Double-cardanic for measuring drives



For legend of pictogram please refer to flapper on the cover



COUNTEX® - Hub material aluminium/spacer PEEK														
Size	Torque [Nm]		Finish bore d		Dimensions [mm]				Displacements			Torsion spring stiffness C_T [Nm/rad]	Radial stiffness C_R [N/mm]	Axial restoring force F_A [N]
	T_{KN}	$T_{K max}$	Min.	Max.	D	l_1/l_2	E	L	Radial ΔK_r [mm]	Axial ΔK_a [mm]	Angular ΔK_w [degree]			
6	0.3	0.6	2	6	15	4	4	12	0.05	-0.3/+0.6	0.36	48	26	10
12	0.5	1.0	2	12	22	6	3.5	15.5	0.10	-0.5/+1.0	0.45	120	65	25
14	1.0	2.0	5	14	31	8	4	20	0.12	-0.5/+1.0	0.57	235	70	27

General description

COUNTEX® is a three-part, backlash-free and torsionally stiff coupling specifically developed for the demands in measuring and control technology.

Its axial plug-in ability combined with the geometry of hubs results in a coupling system with short dimensions, easy to assemble. The material of the spacer is resistant to high temperatures ensuring almost continuous properties of the coupling system even with temperatures up to 160 °C.

Applications

The measuring and control technology demands for high torsion spring stiffness of the coupling in order to realize reproducible positioning. At the same time the coupling has to compensate for displacements with no big forces causing stresses on the adjacent filigree components.

With its spacer made of high-temperature resistant nylon our COUNTEX® ensures almost constant torsion spring stiffness even with high temperatures. The double-cardanic principle of COUNTEX® reduces the restoring forces to a minimum. Nevertheless it has very compact dimensions which make it excellently suitable for tight mounting spaces.

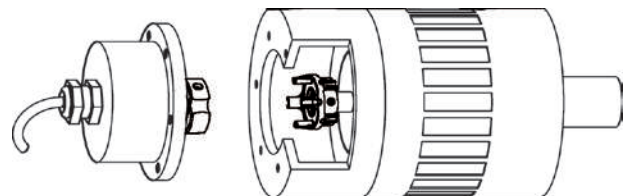

Use in potentially explosive atmospheres

COUNTEX® couplings are suitable for positioning transmission in drives used in potentially explosive atmospheres. The couplings are assessed and approved according to EU directive 2014/34/EU as units of category 2G/2D and thus suitable for the use in potentially explosive atmospheres of zone 1, 2, 21 and 22. Please read through our information included in the respective Type Examination Certificate and the operating and assembly instructions at www.ktr.com.



Ordering example:	COUNTEX® 14	1.1 - Ø6.35		1.1 - Ø10	
	Coupling size	Hub design	Finish bore d ₁	Hub design	Finish bore d ₂

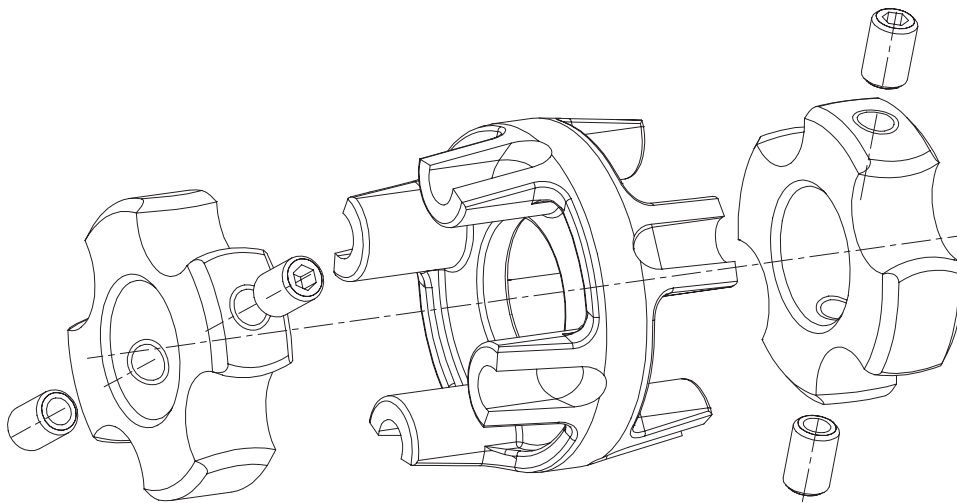
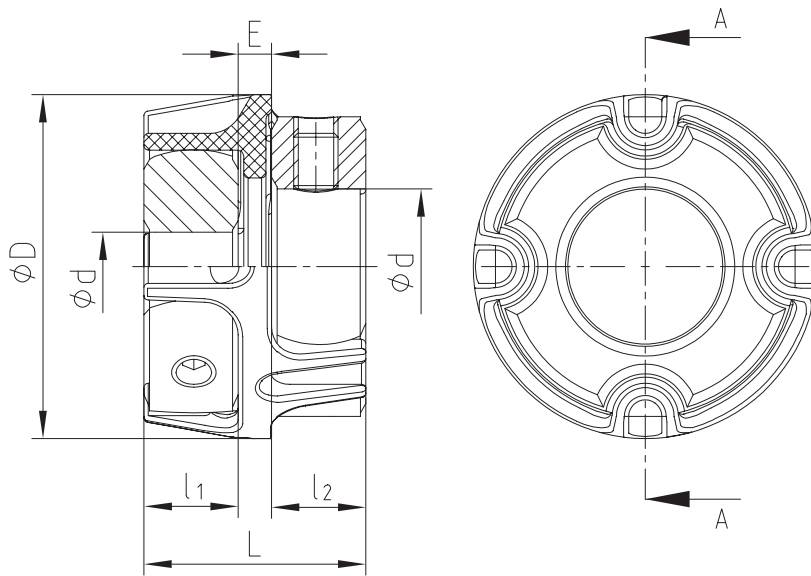

Types of hubs

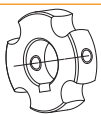

Type 1.0
with feather keyway and setscrew

Positive-locking power transmission. Permissible torque depending on the permissible surface pressure. Not suitable for backlash-free power transmission with heavily reversing operation.

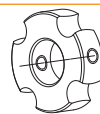

Type 1.1
without feather keyway, with setscrew

Non-positive torque transmission. Suitable for backlash-free transmission of very small torques.
Standard

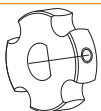

Type 1.3
with spline bore

Positive-locking power transmission. Spline on request of customers (e. g. for shaft with flattening).



Type 1.2
without feather keyway, without setscrew

For low torques. Suitable for bonding or pressing onto the shaft.



Steel lamina couplings

Types and operating description 180

RADEX®-N

General information and types of hubs	182
Types and applications	183
Technical data	184
Standard types	186
Customized types	188
Corrosion-resistant type for large shaft distances	189
Standard series NANA 3 for pump drives in accordance with API 610	190



RIGIFLEX®-N

General information and types of hubs	192
Technical data	193
Type A	195
Type A-J	196
Type A-H	197

RIGIFLEX®-HP

Type C	198
Type L	199

Please note: torque increase



Years of experience with applications at customer sites and additional test series in the KTR test field in Rheine enabled us to determine potentials allowing for an increase of rated and maximum torques with some sizes of this series:

RADEX®-N



RIGIFLEX®-N



RIGIFLEX®-HP



STEEL LAMINA COUPLINGS

TYPES AND OPERATING DESCRIPTION

Properties of lamina couplings



Product	RADEX®-N	RIGIFLEX®-N	RIGIFLEX®-HP
Type	Steel lamina coupling		High-performance steel lamina coupling
Features			
Torsionally rigid	●	●	●
Backlash-free	●	●	●
Maintenance-free	●	●	●
Compensating for misalignment	●	●	●
Special features			
Stock programme	Basic programme available from stock, customized solutions available	Basic programme available from stock, customized solutions available	For customized solutions, applications in high performance ranges and on high-speed drives
Applications / core industries	Pumps, compressors, fans	Pumps, compressors, fans	Pumps, turbo compressors, turbines
API	610	610 & 671	610 & 671
Performance data			
Max. rated torque T_{KN} [Nm]	280,000	280,000	330,000
Max. speed n [rpm]	20,000	23,000	17,300
Max. operating temperature T [°C]	280	280	280
Standard materials			
Hubs			
Steel (S355J2)	●	●	
Q & T steel (C45N)	●	●	
Q & T steel (42CrMo4V)			●
Q & T steel (30CrNiMo8)			●
Spacers			
Steel (S355J2)	●	●	
Q & T steel (C45N)	●	●	
Q & T steel (42CrMo4V)	with torsion shafts		●
Q & T steel (30CrNiMo8)	with torsion shafts		●
Special materials (corrosion-resistant)			
Hubs			
Steel (1.4305)	●		○
Steel (1.4404)	●		○
Spacers			
Steel (1.4305)	●		
Steel (1.4404)	●		
Spacer made of Composite GRP (fibre glass)	●	○	○
Spacer made of Composite CFRP (carbon fibre)	●		
Surface coating	Painting, phosphating, zinc-plating and passivating, Geomet, Tenifer Q	Painting, phosphating, zinc-plating and passivating, Geomet, Tenifer Q	Painting, phosphating, zinc-plating and passivating, Geomet, Tenifer Q

● ≈ Standard
○ ≈ On request

STEEL LAMINA COUPLINGS

TYPES AND OPERATING DESCRIPTION

Product finder of lamina couplings

Product	RADEX®-N	RIGIFLEX®-N	RIGIFLEX®-HP
Type	Steel lamina coupling		High-performance steel lamina coupling
Geometries			
Design	Single- and double-cardanic	Double-cardanic	Double-cardanic
Max. shaft diameter [mm]	330	400	380
Radial assembly	●	●	●
Certifications/type examinations			
ATEX	 ●	●	●
GOST R/ GOST TR	 ●	●	●
DNV GL	 ●	●	●

● ≈ Standard

Details on lamina couplings

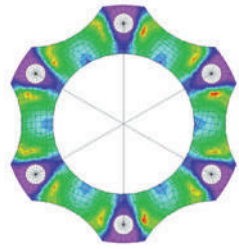
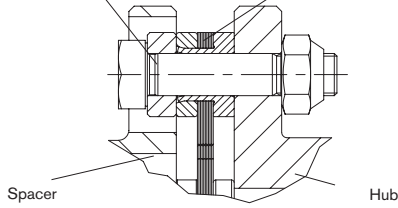
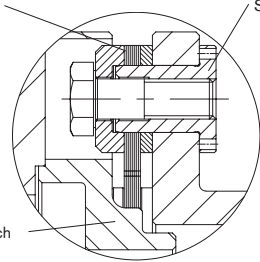
<p>Laminas - lamina shape optimized by FEM</p> <p>The steel lamina sets made of high-strength, stainless spring steel were developed based on FEM calculations. Considering the necessary options of displacement of the coupling, the optimum shape with regard to torque transmission and torsional stiffness was aimed at. The waisted shape of the steel laminas on the outside diameter resulted from this optimization calculation.</p>	
<p>RADEX®-N - Lamina sets with dowel screws</p> <p>The heart of the steel lamina coupling are the lamina sets and their connection to hubs and spacers. High-strength, special dowel screws that are alternately screwed to hubs and spacer allow for a combination of frictional fit and positive locking. Thus a high power density with at the same time ease of displacement and low restoring forces are ensured.</p>	<p>Dowel screw (combination of frictional fit and positive locking)</p> <p>Lamina set with screws</p>  <p>Spacer</p> <p>Hub</p>
<p>RIGIFLEX®-N - Protecting the spacer</p> <p>Since our main idea with the development of RIGIFLEX®-N was to comply with the standards of API 610 and API 671, the spacer is secured by a safety catch, too. In case that the laminas break the spacer remains inside the coupling. In general the spacer is supplied along with a lamina set pre-assembled by the manufacturer. These are connected with the spacers or flanges fully free from backlash via positive-locking special pins.</p>	<p>Lamina set</p> <p>Special pins</p>  <p>Safety catch</p>

RADEX®-N

Steel lamina couplings

General advice

Advice on assembly and operation

See our mounting instructions KTR standard 471 10 at www.ktr.com. With the assembly it is important to make sure that the lamina sets are assembled free from distortion in axial direction. If the finish bore is machined by the customer, the concentricity and axial running tolerances have to be adhered to (see sketch).

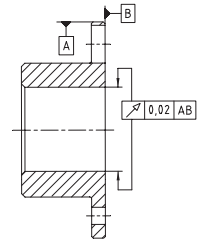

Installation

RADEX®-N couplings are designed for horizontal installation. For vertical installation the spacer might have to be supported (see sketch). Please consult with us.

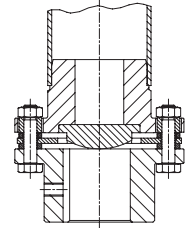

Delivery condition

RADEX®-N couplings are delivered as individual components (can be delivered assembled on request). The hubs can be supplied unbored or with finish bore and feather keyway or with a frictionally engaged shaft-hub-connection. The shaft-hub-connection needs to be inspected by the customer (consult with KTR, if necessary).



Balancing

On request of the customer the RADEX®-N couplings can be balanced. For standard applications this is not necessary due to accurate machining of the coupling. Please consult with us, if necessary.

Safety regulations

The coupling has to be dimensioned in a way that the permissible coupling load is not exceeded during any operating condition. For this purpose the actual loads have to be compared to the permissible parameters of the coupling. The customer has to protect rotating parts from accidental contact (Safety of Machinery DIN EN 292 part 2). Please take precautions that there is sufficient coupling protection in case of fracture of the coupling caused by overload.

Types of hubs

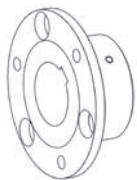

Type 1.0 hub with feather keyway and setscrew

Positive locking torque transmission, permissible torque depending on the permissible surface pressure. Not suitable for backlash-free torque transmission with heavily reversing operation.

Type 1.1 hub without feather keyway, with setscrew

Non-positive torque transmission for crimp and glued connections. (No ATEX approval)

Type 1.2 hub without feather keyway, without setscrew

Non-positive torque transmission for crimp and glued connections. (No ATEX approval)

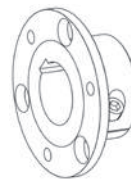

Type 2.5 clamping hub double slotted, without feather keyway

Frictionally engaged, backlash-free shaft-hub-connection. Transmittable torques depending on bore diameter. For ATEX category 3 only.

Type 2.6 clamping hub double slotted, with feather keyway

Positive shaft-hub connection with additional frictional fit. The friction fit prevents or reduces reverse backlash, respectively.

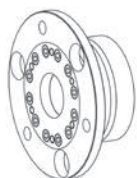

Type 6.0 clamping ring hub

Integrated frictionally engaged shaft-hub-connection for the transmission of higher torques. Clamping screws on lamina side. Transmittable torques depending on bore diameter. Suitable for high speeds.

Type 6.5 clamping ring hub

Integrated frictionally engaged shaft-hub-connection for the transmission of higher torques. Clamping screws outside. Transmittable torques depending on bore diameter. Suitable for high speeds.

RADEX®-N

Steel lamina couplings

Types and applications

Type NN (see page 182)

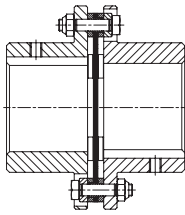

Type NANA 1/NANA 2 (see page 182)

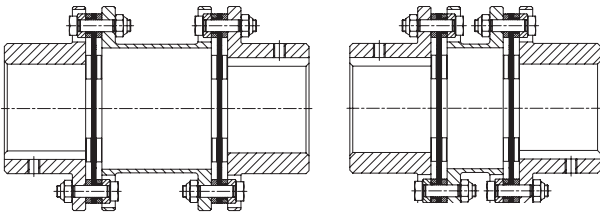

Type NANA 3 (see page 186)

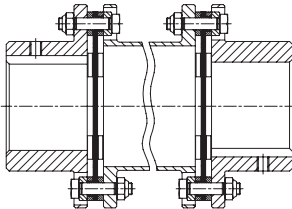

Type NANA 4 (see page 184)

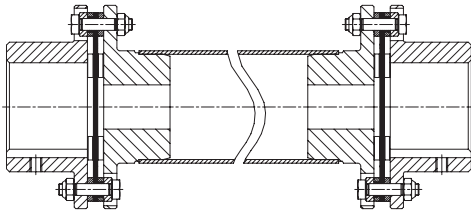

Type NNW (see page 184)

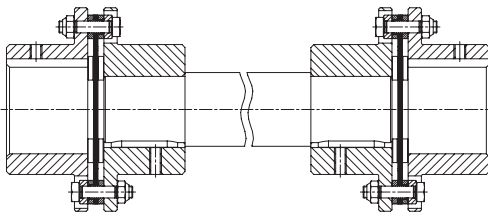

Type NNZ (see page 183)

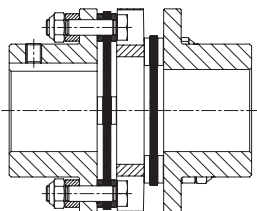

Type NENE 1 (see page 183)

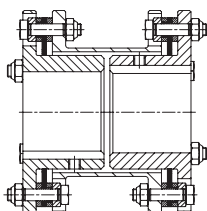

Features

- Single-cardanic design
- Only angular and axial displacement permissible
- High torsional rigidity
- Compact dimensions

Applications

- Mixers
- Agitators
- Immersion pumps
- Fans
- Applications with high radial load

- Double-cardanic design
- Compensating for high misalignment with low restoring forces
- Standard spacers available from stock

- Paper machines
- Printing and processing machines
- Materials handling
- Steel mills
- Generators
- Grinding machines

- Double-cardanic design
- Spacers adapted to standard dimensions of pumps
- Radial assembly, no shifting of the machine required
- Available according to API 610

- Process pumps
- Water pumps
- Pumps according to API standard
- Turbines
- Compressors

- Customized spacers
- Max. shaft distance dimension up to approx. 6 m
- Welded intermediate pipes for high torsional rigidity

- Foil and paper machines
- Pallet and conveyor systems
- Robotic palletizers
- Test benches
- Cooling towers/blowers

- Customized spacers
- Coupling consisting of 2-off type NN with intermediate shaft
- For drives with relatively low speeds

- Low-speed drives with large shaft distance dimensions
- Agitators
- Crushers
- Presses
- Packaging machines

- Compact double-cardanic coupling
- Cannot be radially assembled
- With intermediate disk
- Ideal for replacing curved-tooth gear couplings made of steel
- Standard type up to size 70

- Robotics
- Paper machines and inserters
- Machine tools
- Packaging machines
- Test benches

- With reduced hubs
- Compact double-cardanic design
- Spacer cannot be radially assembled
- Variable spacer length

- Applications with short shaft distance dimensions
- Replacement of curved-tooth gear couplings made of steel

RADEX®-N

Steel lamina couplings

Technical data

The following lamina types are to be distinguished with RADEX®-N:

Size 20 – 50
(lamina with 4 holes)

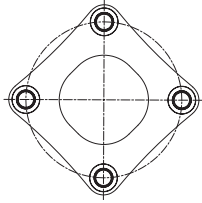

Size 60 – 135
(lamina with 6 holes)

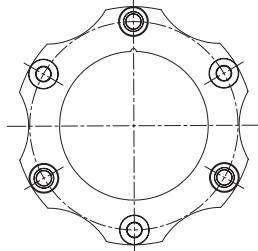

Size 136 – 336
(lamina with 6 holes)

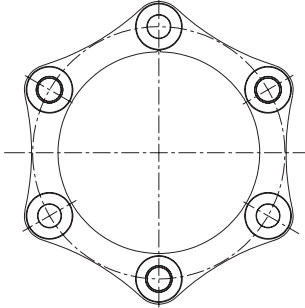

Size 138 – 338
(lamina with 8 holes)

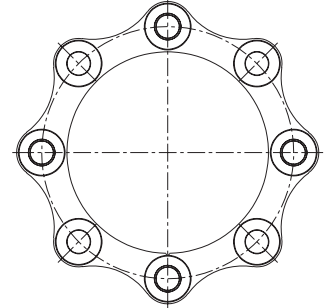

Torques and displacements

Size	Lamina shape	Torques [Nm] ¹⁾			Angular [°] each lamina	Perm. displacements ²⁾			
		TKN	TK max	TKW		Axial [mm]		Radial [mm]	
						NN	NANA 1/ NANA2/ NNZ	NANA 1	NANA 2/NNZ
20	lamina with 4 holes	30	60	15	1.0	0.60	1.2	1.0	0.2
25		60	120	30	1.0	0.80	1.6	1.0	0.2
35		120	240	60	1.0	1.00	2.0	1.1	0.3
38		240	480	120	1.0	1.20	2.4	1.2	0.3
42		320	640	160	1.0	1.40	2.8	1.2	0.4
50		470	940	235	1.0	1.60	3.2	1.5	0.4
60		900	1800	450	1.0	1.00	2.0	1.5	0.8
70		1300	2600	650	1.0	1.10	2.2	1.8	1.0
80		1800	3600	900	1.0	1.30	2.6	2.1	1.2
85		2600	5200	1300	1.0	1.30	2.6	2.2	1.2
90	4600	9200	2300	1.0	1.00	2.0	2.2	1.1	
105	5600	11200	2800	1.0	1.20	2.4	2.4	1.4	
115	9900	19800	4950	1.0	1.40	2.8	2.5	1.5	
135	lamina with 6 holes	13500	27000	6750	1.0	1.75	3.5	3.8	–
136	lamina with 6 holes	17500	35000	8750	0.7	1.85	3.7		
156		25000	50000	12500	0.7	2.10	4.2		
166		35000	70000	17500	0.7	2.25	4.5		
186		42000	84000	21000	0.7	2.40	4.8		
206		52500	105000	26250	0.7	2.60	5.2		
246		90000	180000	45000	0.7	3.00	6.0		
286		150000	300000	75000	0.7	3.35	6.7		
336		210000	420000	105000	0.7	3.75	7.5		
138		23000	46000	11500	0.5	1.30	2.6	Depending on shaft distance dimension E	
158		33000	66000	16500	0.5	1.40	2.8		
168	45000	90000	22500	0.5	1.50	3.0			
188	56000	112000	28000	0.5	1.60	3.2			
208	70000	140000	35000	0.5	1.75	3.5			
248	120000	240000	60000	0.5	2.00	4.0			
288	200000	400000	100000	0.5	2.40	4.5			
338	280000	560000	140000	0.5	2.50	5.0			

¹⁾ = Years of experience with applications at customer sites and additional test series in the KTR test field in Rheine enabled us to determine potentials allowing for an increase of the rated and maximum torques with some sizes of this series.

Permissible speeds and torsional stiffness figures

Size	Max. speed [rpm] (higher speeds on request)	Torsion spring stiffness x 10 ⁶ [Nm/rad] per lamina set	Size	Max. speed [rpm] (higher speeds on request)	Torsion spring stiffness x 10 ⁶ [Nm/rad] per lamina set
20	20400	0.02	156	3500	17.00
25	16800	0.03	166	3300	19.00
35	13900	0.11	186	3000	25.00
38	12000	0.20	206	2800	31.00
42	11000	0.28	246	2300	55.00
50	9000	0.50	286	2000	79.00
60	8200	0.56	336	1800	125.00
70	7300	0.90	138	3800	20.00
80	6300	1.10	158	3500	26.00
85	5900	1.50	168	3300	30.00
90	5400	2.00	188	3000	39.00
105	5000	2.50	208	2800	49.00
115	4300	3.50	248	2300	83.00
135	3700	6.90	288	2000	125.00
136	3800	13.00	338	1800	200.00

¹⁾ For selection of coupling see page 18 et seqq.

²⁾ The permissible displacement figures specified are maximum figures which must not arise simultaneously. If radial, axial and angular displacements arise in parallel, the figures need to be reduced.

RADEX[®]-N

Steel lamina couplings

Technical data

Weights and mass moments of inertia						
Size	Hub ¹⁾ [kg] / [kgm ²]	Lamina set [kg] / [kgm ²]	NN ¹⁾ complete [kg] / [kgm ²]	NANA 1 ¹⁾ complete [kg] / [kgm ²]	NANA 2 ¹⁾ complete [kg] / [kgm ²]	NNZ ¹⁾ complete [kg] / [kgm ²]
20	0.13 / 0.000043	0.04 / 0.00002	0.3 / 0.00011	0.6 / 0.000204	–	0.4 / 0.000166
25	0.2 / 0.000116	0.08 / 0.00005	0.56 / 0.00028	0.9 / 0.000522	–	0.8 / 0.000414
35	0.6 / 0.00042	0.10 / 0.00010	1.2 / 0.00094	1.9 / 0.00158	–	1.6 / 0.00129
38	0.8 / 0.00073	0.20 / 0.00026	1.8 / 0.0017	2.8 / 0.00303	–	2.4 / 0.00247
42	1.1 / 0.00123	0.25 / 0.00040	2.4 / 0.0029	3.6 / 0.00482	–	3.1 / 0.00409
50	1.7 / 0.00291	0.46 / 0.0010	4.0 / 0.0068	6.2 / 0.0118	–	5.1 / 0.00932
60	1.9 / 0.00378	0.40 / 0.0012	4.2 / 0.0087	6.0 / 0.0141	5.8 / 0.0138	5.3 / 0.0120
70	2.8 / 0.00714	0.42 / 0.0016	6.0 / 0.016	8.6 / 0.0253	8.2 / 0.0242	7.5 / 0.0214
80	4.1 / 0.0134	0.72 / 0.0037	9.0 / 0.031	12.6 / 0.0476	12.0 / 0.0458	11.1 / 0.0410
85	5.1 / 0.0195	1.0 / 0.0065	11.2 / 0.046	16.2 / 0.0734	15.5 / 0.0711	14.8 / 0.0650
90	6.2 / 0.0282	2.3 / 0.0162	14.7 / 0.073	22.0 / 0.121	21.3 / 0.119	20.1 / 0.108
105	7.6 / 0.0414	2.2 / 0.0180	17.4 / 0.101	25.8 / 0.165	24.6 / 0.159	23.1 / 0.145
115	12.0 / 0.0899	4.0 / 0.0433	27.9 / 0.223	42.8 / 0.381	41.2 / 0.372	38.3 / 0.333
135	19.0 / 0.187	7.3 / 0.105	45.1 / 0.478	71.3 / 0.835	–	–
136	16.8 / 0.153	7.9 / 0.113	41.4 / 0.419	–	–	–
156	20.2 / 0.217	11.9 / 0.200	52.2 / 0.634	–	–	–
166	30.0 / 0.373	12.3 / 0.255	72.3 / 1.001	–	–	–
186	42.0 / 0.629	12.7 / 0.318	96.7 / 1.576	–	–	–
206	55.1 / 1.004	18.2 / 0.548	128.3 / 2.556	–	–	–
246	85.9 / 2.229	31.2 / 1.304	203.1 / 5.762	–	–	–
286	145.1 / 4.977	44.4 / 2.495	334.4 / 12.449	–	–	–
336	223.9 / 10.486	64.2 / 4.74	512.0 / 25.712	–	–	–
138	16.2 / 0.145	9.9 / 0.143	42.3 / 0.433	Depending on shaft distance dimension E	Depending on shaft distance dimension E	–
158	19.5 / 0.205	14.9 / 0.252	54.0 / 0.662	–	–	–
168	29.4 / 0.360	15.2 / 0.318	74.0 / 1.038	–	–	–
188	41.7 / 0.611	15.6 / 0.396	99.0 / 1.618	–	–	–
208	54.1 / 0.971	22.4 / 0.680	130.5 / 2.622	–	–	–
248	84.0 / 2.144	38.2 / 1.605	206.2 / 5.893	–	–	–
288	142.5 / 4.823	53.8 / 3.056	338.8 / 12.702	–	–	–
338	220.1 / 10.18	78.0 / 5.817	518.2 / 26.177	–	–	–

¹⁾ Hubs with max. bore

Cylindrical bores

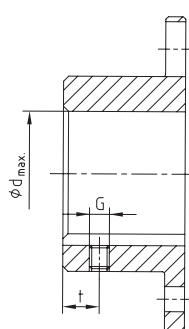

Standard hub 1.0 with feather keyway according to DIN 6885 sheet 1									
Size	d _{max.}	G	t	T _A [Nm]	Size	d _{max.}	G	t	T _A [Nm]
20	20	M5	6	2.0	105	110	M12	30	40.0
25	25	M5	8	2.0	115	120	M12	30	40.0
35	38	M6	15	4.8	135	135			
38	42	M6	15	4.8	136 / 138	135			
42	50	M8	20	10.0	156 / 158	150			
50	55	M8	20	10.0	166 / 168	170			
60	65	M8	20	10.0	186 / 188	190			
70	75	M10	20	17.0	206 / 208	210			
80	85	M10	20	17.0	246 / 248	245			
85	90	M10	25	17.0	286 / 288	290			
90	100	M12	25	40.0	336 / 338	340			

Backlash-free shaft-hub connections without feather key

Selection: If used in potentially explosive atmospheres the clamping ring hubs must be selected in a way that there is a minimum safety factor of $s = 2$ between the peak torque of the machine including all operating parameters and the nominal torque and frictional locking torque of the coupling.

Clamping ring hub type 6.5
(clamping screws outside)

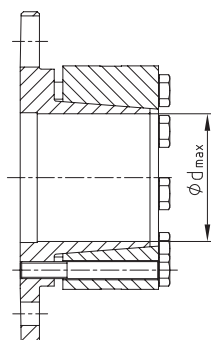

Clamping ring hub type 6.0
(clamping screws inside)

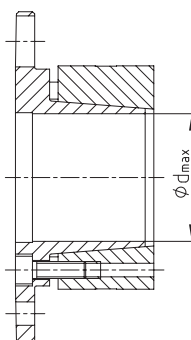

Type with CLAMPEX[®] element type 603

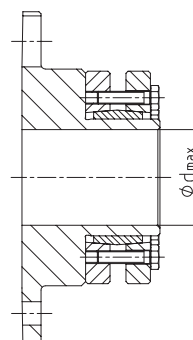

RADEX®-N NN, NANA 1 and NANA 2 Steel lamina couplings

Standard types

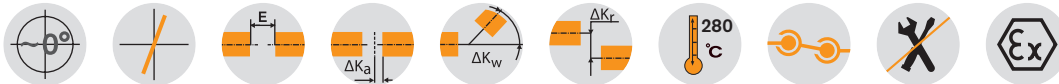

Components

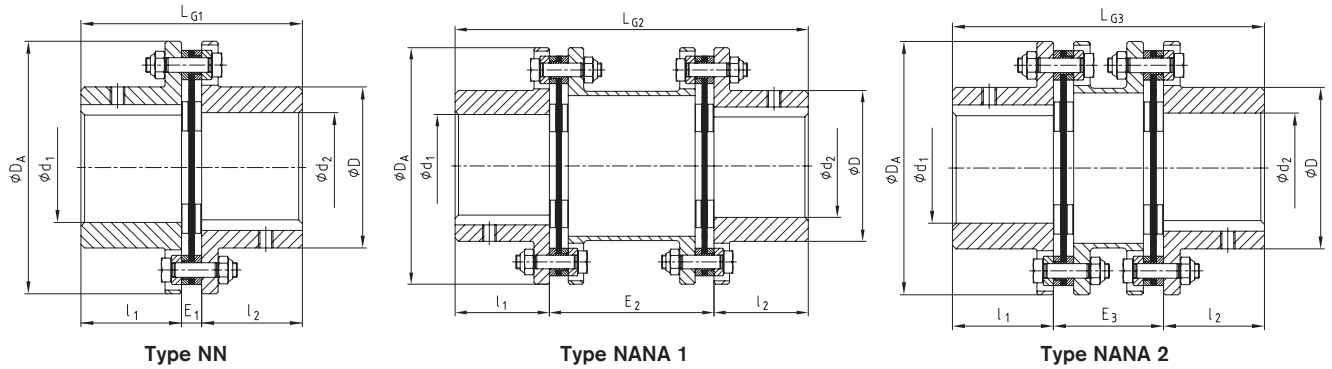

RADEX®-N Types NN, NANA 1, NANA 2										
Size	Max. finish bore		Dimensions [mm]							
	d ₁ , d ₂	D	D _A	l ₁ , l ₂	L _{G1}	E ₁	L _{G2}	E ₂	L _{G3}	E ₃
20	20	32	56	20	45	5	100	60	-	-
25	25	40	68	25	56	6	110	60	-	-
35	38	54	82	40	86	6	150	70	-	-
38	42	58	94	45	98	8	170	80	-	-
42	50	68	104	45	100	10	170	80	-	-
50	55	78	126	55	121	11	206	96	-	-
60	65	88	138	55	121	11	206	96	170	60
70	75	102	156	65	141	11	246	116	200	70
80	85	117	179	75	164	14	286	136	233	83
85	90	123	191	80	175	15	300	140	246	86
90	100	132	210	80	175	15	300	140	251	91
105	110	147	225	90	200	20	340	160	281	101
115	120	163	265	100	223	23	370	170	309	109
135	135	184	305	135	297	27	520	250	-	-
136	135	180	300	135	293	23				
156	150	195	325	150	327	27				
166	170	225	350	165	361	31				
186	190	250	380	185	401	31				
206	210	275	420	200	437	37				
246	245	320	500	240	524	44				
286	290	383	567	280	612	52				
336	340	445	660	330	718	58				
138	135	180	300	135	293	23				
158	150	195	325	150	327	27				
168	170	225	350	165	361	31				
188	190	250	380	185	401	31				
208	210	275	420	200	437	37				
248	245	320	500	240	524	44				
288	290	383	567	280	612	52				
338	340	445	660	330	718	58				

Ordering example:	RADEX®-N 60	NANA 1	Ø50	Ø60
	Coupling size	Type	Finish bore d ₁	Finish bore d ₂

RADEX®-N NENA 1, NENE 1, NENA 2 and NNZ Steel lamina couplings

Standard types



For legend of pictogram please refer to flapper on the cover

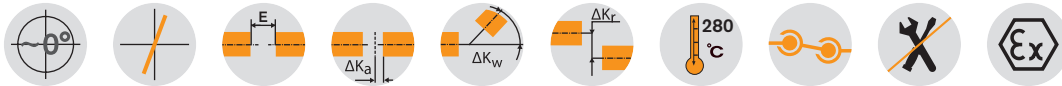

Components

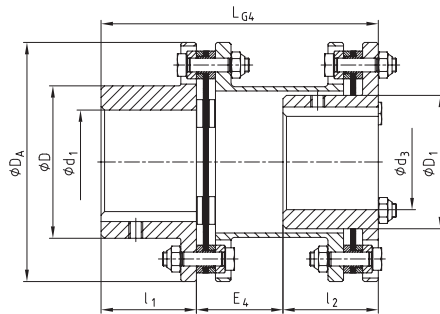

Type NENA 1

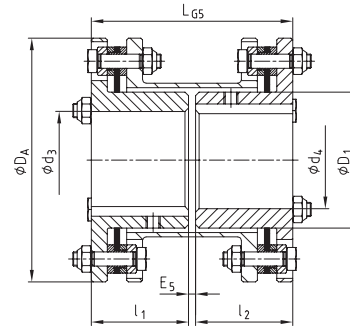

Type NENE 1

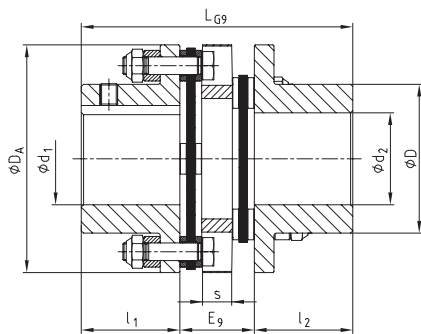

Type NNZ

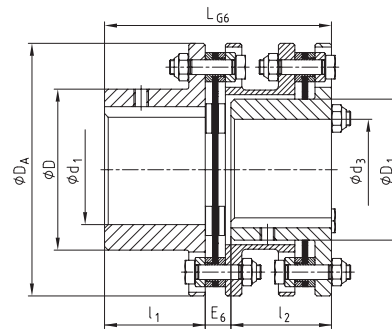

Type NENA 2

RADEX®-N Types NENA 1, NENE 1, NENA 2, NNZ

Size	Max. finish bore		Dimensions [mm]												
	d ₁ , d ₂	d ₃ , d ₄	D	D ₁	D _A	l ₁ , l ₂	LG4	E ₄	LG5	E ₅	LG6	E ₆	LG9	E ₉	
20	20	-	32	-	56	20	-	-	-	-	-	-	58	18	
25	25	-	40	-	68	25	-	-	-	-	-	-	70	20	
35	38	-	54	-	82	40	-	-	-	-	-	-	102	22	
38	42	-	58	-	94	45	-	-	-	-	-	-	118	28	
42	50	-	68	-	104	45	-	-	-	-	-	-	124	34	
50	55	-	78	-	126	55	-	-	-	-	-	-	144	34	
60	65	55	88	77	138	55	160	50	114	4	124	14	144	34	
70	75	65	102	90	156	65	190	60	134	4	144	14	166	36	
80	85	75	117	104	179	75	220	70	154	4	167	17	-	-	
85	90	80	123	112	191	80	232	72	164	4	178	18	-	-	
90	100	85	132	119	210	80	233	73	166	6	184	24	-	-	
105	110	90	147	128	225	90	263	83	186	6	204	24	-	-	
115	120	100	163	145	265	100	288	88	206	6	227	27	-	-	

Ordering example:

RADEX®-N 60	NENA 1	Ø50	Ø60
Coupling size	Type	Finish bore d ₁	Finish bore d ₂

RADEX®-N NANA 4 and NNW Steel lamina couplings

Customized types

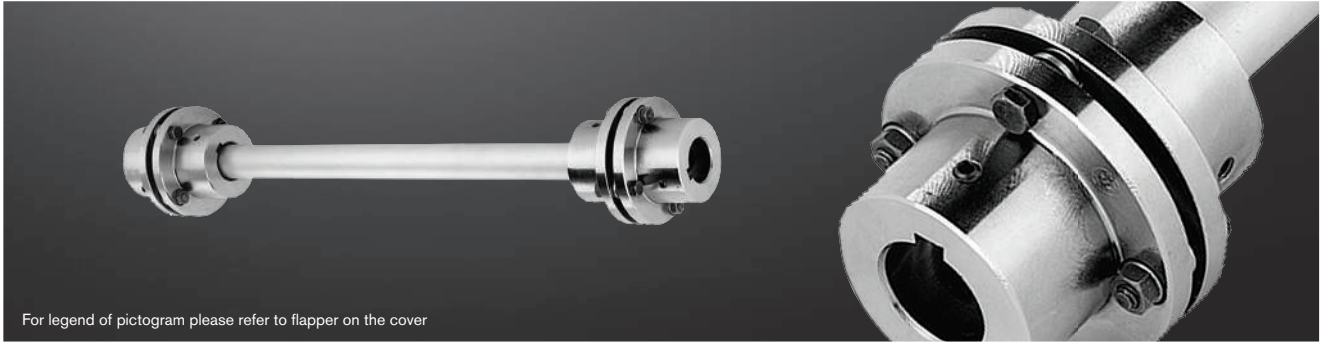

For legend of pictogram please refer to flapper on the cover

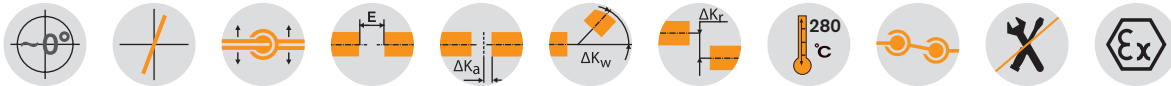

Components

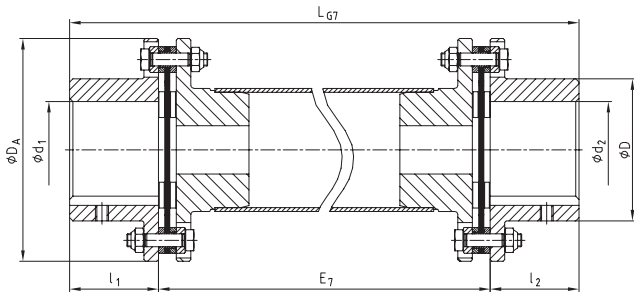

Type NANA 4

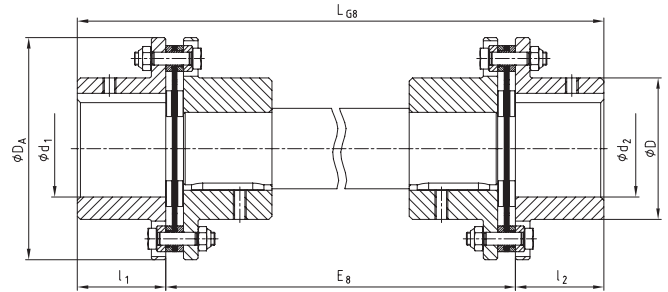

Type NNW

RADEX®-N Types NANA 4, NNZ and NNW								
Size	Max. finish bore	Dimensions [mm]						
	d ₁ , d ₂	D	DA	l ₁ , l ₂	LG7	E7	LG8	E8
20	20	32	56	20				
25	25	40	68	25				
35	38	54	82	40				
38	42	58	94	45				
42	50	68	104	45				
50	55	78	126	55				
60	65	88	138	55				
70	75	102	156	65				
80	85	117	179	75				
85	90	123	191	80				
90	100	132	210	80				
105	110	147	225	90				
115	120	163	265	100				
135	135	184	305	135				
136	135	180	300	135				
156	150	195	325	150				
166	170	225	350	165				
186	190	250	380	185				
206	210	275	420	200				
246	245	320	500	240				
286	290	383	567	280				
336	340	445	660	300				
138	135	180	300	135				
158	150	195	325	150				
168	170	225	350	165				
188	190	250	380	185				
208	210	275	420	200				
248	245	320	500	240				
288	290	383	567	280				
338	340	445	660	300				

Ordering example:	RADEX®-N 60	NANA 4	Ø50	Ø60	2500
	Coupling size	Type	Finish bore d ₁	Finish bore d ₂	Shaft distance dimension

RADEX[®]-N Composite Steel lamina couplings

Corrosion-resistant type for large shaft distances



For legend of pictogram please refer to flapper on the cover

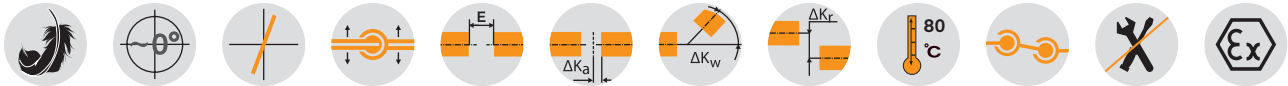

Components

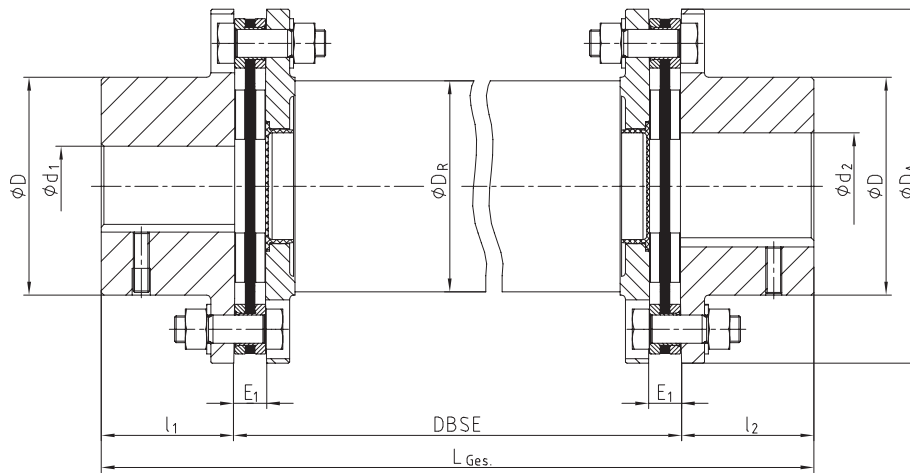

RADEX [®] -N Type NANA 4 CFK											
Size	Torque [Nm] ¹⁾		Dimensions [mm]								
	T _{KN}	T _{K max}	D _A	d ₁ , d ₂ max.	D	l ₁ , l ₂	E ₁	DBSE	L _{total}	Composite tube D _R	Max. DBSE ²⁾ with 1500 rpm
70	800	1600	149	75	102	65	11	As specified by the customer	l ₁ + l ₂ + DBSE	95	3500
85	1800	3600	184	90	123	80	15			117	3900
90	2500	5000	200	100	135	80	15			128	4100
115	4500	9000	253	120	163	100	23			160	4600

¹⁾ For selection of coupling see page 18 et seqq.

²⁾ For higher speeds or bigger shaft distance dimensions please consult with KTR's engineering department (+49 5971 798-484). The above-mentioned characteristic figures (e. g. max. DBSE) can be varied by composite tubes optimized for the application, if necessary.

Particularly the steel lamina couplings are well suited for applications with especially large distance dimensions between the drive and the driven side (e. g. cooling towers, fans etc.) due to their design. In order to be able to generate high speeds with large distance dimensions, RADEX[®]-N couplings with intermediate shafts made of glass fiber or carbon fiber reinforced nylon (GRP or CFRP) are used, if necessary.

Ordering example:	RADEX [®] -N 85	NANA 4 CFK	Ø60	Ø70	3000
	Coupling size	Type	Finish bore d ₁	Finish bore d ₂	Shaft distance dimension

RADEX®-N NANA 3

Steel lamina couplings

Pump drives in accordance with API 610



For legend of pictogram please refer to flapper on the cover

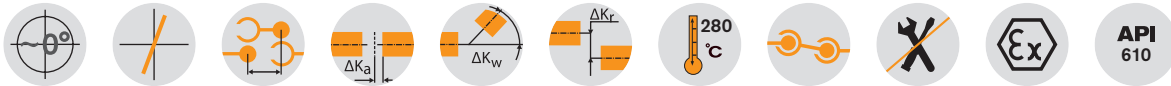

RADEX®-N Type NANA 3							
Size	Max. finish bore	Dimensions [mm]				Perm. displacements	
	d	D	D _A	E ^{Standard} ¹⁾	l ₁ , l ₂	Angular [°] each lamina	Axial [mm]
42	50	68	104	100	45	1.0	2.8
50	55	78	126	140/180	55	1.0	3.2
60	65	88	138	100/140/180/250	55	1.0	2.0
70	75	102	156	100/140/180	65	1.0	2.2
80	85	117	179	100/140/180/250	75	1.0	2.6
85	90	123	191	100/140/180/250	80	1.0	2.3
90	100	132	210	140/180/250	80	1.0	2.0
105	110	147	225	250	90	1.0	2.4
115	120	163	265	250	100	1.0	2.8
135	135	184	305	250	135	1.0	3.5
136	135	180	300		135	0.7	3.7
156	150	195	325		150	0.7	4.2
166	170	225	350		165	0.7	4.5
186	190	250	380		185	0.7	4.8
206	210	275	420		200	0.7	5.2
246	245	320	500		240	0.7	6.0
286	290	383	567		280	0.7	6.7
336	340	445	660		330	0.7	7.5
138	135	180	300	As specified by the customer	135	0.5	2.6
158	150	195	325		150	0.5	2.8
168	170	225	350		165	0.5	3.0
188	190	250	380		185	0.5	3.2
208	210	275	420		200	0.5	3.5
248	245	320	500		240	0.5	4.0
288	290	383	567		280	0.5	4.5
338	340	445	660		330	0.5	5.0

¹⁾ Other distance dimensions E available on request.

Ordering example:	RADEX®-N 60	NANA 3	Ø50	Ø60	140
	Coupling size	Type	Finish bore d ₁	Finish bore d ₂	Shaft distance dimension

Components

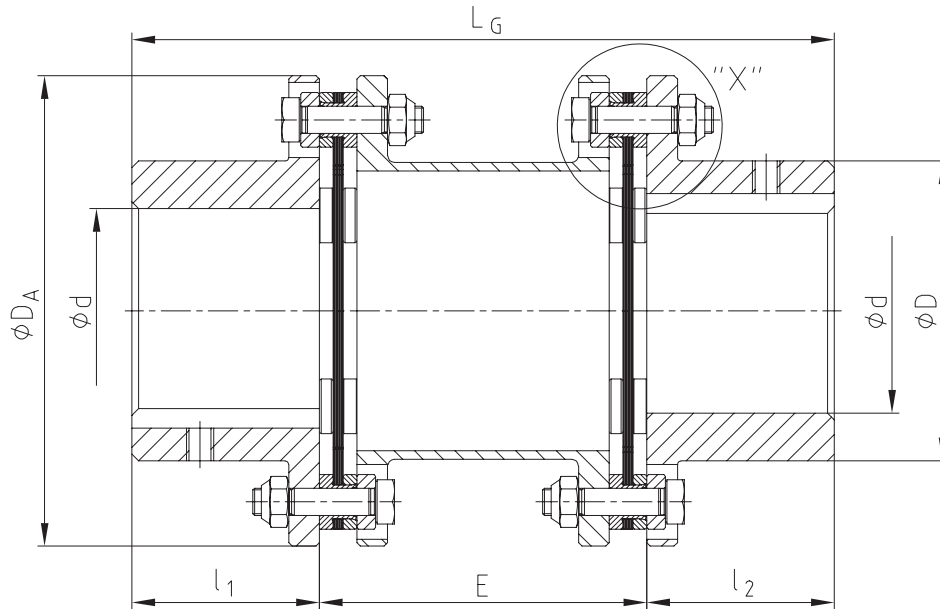

Detail "X"

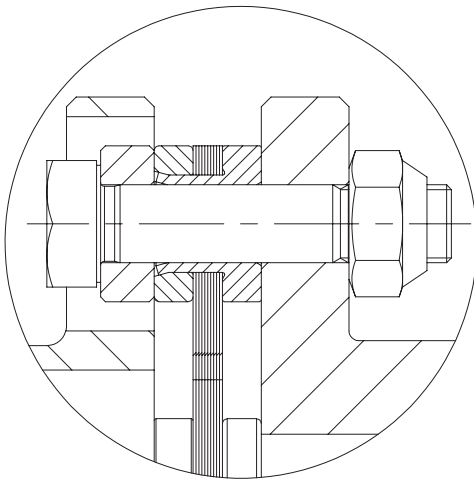

Safety catch of the spacer:
The lamina sets are provided with a sleeve in order to fasten the spacer if the laminas break.

RIGIFLEX®-N

Steel lamina couplings

General advice

Advice on assembly and operation

See our mounting instructions KTR standard 47410 at www.ktr.com. With the assembly it is important to make sure that the lamina sets are assembled free from distortion in axial direction.

If the finish bore is machined by the customer, the tolerances for concentricity and axial run-out have to be observed (see illustrations below).

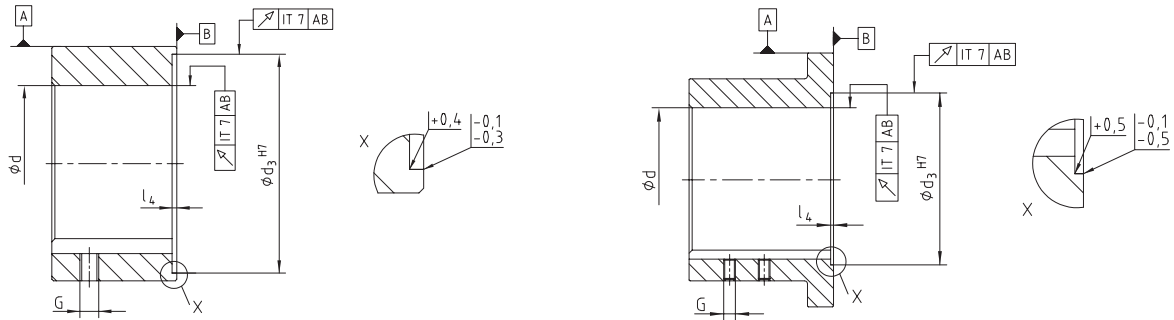

Installation

RIGIFLEX®-N couplings are designed for horizontal installation. For vertical installation the spacer might have to be supported. Please consult with us.

Delivery condition

RIGIFLEX®-N-couplings are supplied as individual parts (assembled on request), with the subassembly of spacers (flanges, lamina sets and spacer) being fully assembled. The hubs can be supplied unbored or with finish bore and feather keyway or with a frictionally engaged shaft-hub-connection. The shaft-hub-connection needs to be inspected by the customer (consult with KTR, if necessary).

Balancing

On request of the customer the RIGIFLEX®-N couplings can be balanced. Please consult with us, if necessary.

Safety regulations

The coupling has to be dimensioned in a way that the permissible coupling load is not exceeded during any operating condition. For this purpose the actual loads have to be compared to the permissible parameters of the coupling. The customer has to protect rotating parts from accidental contact (Safety of Machinery DIN EN 292 part 2). Please take precautions that there is sufficient coupling protection in case of fracture of the coupling caused by overload.

Types of hubs

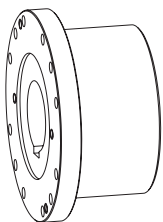

Type 1.0 hub with feather key with setscrew

Positive locking torque transmission, permissible torque depending on the permissible surface pressure.

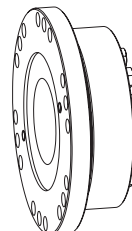

Type with KTR 620 or 603 clamping set

Frictionally engaged torque transmission with external clamping set KTR 620 or KTR 603. Transmittable torques depending on bore diameter.

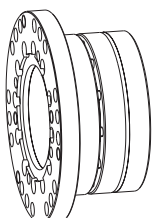

Type 6.0 and 6.5 hub

Integrated frictionally engaged shaft-hub-connection. Transmittable torques depending on bore diameter. Suitable for high speeds.

RIGIFLEX®-N

Steel lamina couplings

Technical data

The following lamina types are to be distinguished with RIGIFLEX®-N:

Size 35 – 65
(lamina with 4 holes)

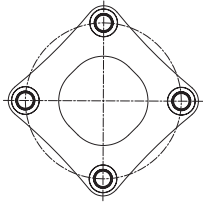

Size 75 – 160
(lamina with 6 holes)

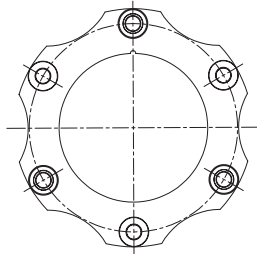

Size 166 – 406
(lamina with 6 holes)

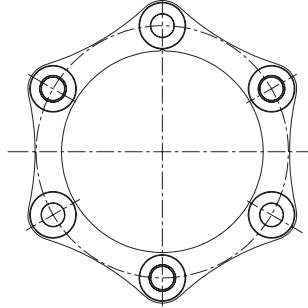

Size 168 – 408
(lamina with 8 holes)

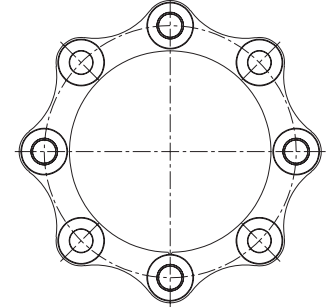

RADEX®-N

Torques and displacements

Size	Lamina shape	Torques [Nm]			Angular displacement ± Kw ¹⁾ [°]	Axial displacement ± Ka [mm]	Perm. displacements				
		TKN	TK max	TKW			Radial ± Kr [mm]				
							E=100	E=140	E=180	E=200	E=250
35	lamina with 4 holes	130	260	65	0.7	1.2	0.90	1.40	–	–	–
50		270	540	135	0.7	1.4	0.77	1.26	–	–	–
65		550	1100	275	0.7	1.5	0.75	1.23	1.72	–	–
75		1100	2200	550	0.7	1.8	0.73	1.22	1.71	–	–
85	lamina with 6 holes	1900	3800	950	0.7	2.1	–	1.14	1.62	1.87	2.48
110		3500	7000	1750	0.7	2.4	–	1.05	1.54	1.78	2.39
120		5750	11500	2875	0.7	2.6	–	1.00	1.49	1.73	2.35
140		10500	21000	5250	0.7	3.3	–	–	–	1.55	2.16
160		16000	32000	8000	0.7	3.8	–	–	–	–	1.99
166		19000	38000	9500	0.7	3.7	Depending on shaft distance dimension E				
196		22500	45000	11250	0.7	4.2					
216		32000	64000	16000	0.7	4.5					
256		52500	105000	26250	0.7	5.2					
306		86000	172000	43000	0.7	6.0					
346	135000	270000	67500	0.7	6.7						
406	210000	420000	105000	0.7	7.5						
168	25000	50000	12500	0.5	2.6						
198	30000	60000	15000	0.5	2.8						
218	42500	85000	21500	0.5	3.0						
258	lamina with 8 holes	70000	140000	35000	0.5	3.5					
308		115000	230000	57500	0.5	4.0					
348		180000	360000	90000	0.5	4.5					
408		280000	560000	140000	0.5	5.0					

¹⁾ Angular displacement each lamina set

If axial, angular and radial shaft displacement arises in parallel please note the following table:

Size	Permissible angular displacement							
	0	0.1	0.2	0.3	0.4	0.5	0.6	0.7
35	1.20	1.00	0.85	0.74	0.60	0.40	0.20	0.00
50	1.40	1.20	1.00	0.80	0.60	0.40	0.20	0.00
65	1.50	1.29	1.07	0.86	0.64	0.43	0.22	0.00
75	1.80	1.54	1.29	1.03	0.77	0.52	0.26	0.00
85	2.10	1.80	1.50	1.20	0.90	0.60	0.30	0.00
110	2.40	2.06	1.71	1.37	1.03	0.69	0.34	0.00
120	2.60	2.23	1.86	1.48	1.11	0.74	0.37	0.00
140	3.30	2.83	2.36	1.88	1.41	0.94	0.47	0.00
160	3.80	3.26	2.71	2.17	1.63	1.09	0.54	0.00
166	3.70	3.17	2.64	2.12	1.59	1.06	0.53	0.00
196	4.20	3.60	3.00	2.40	1.80	1.20	0.60	0.00
216	4.50	3.86	3.21	2.57	1.93	1.29	0.64	0.00
256	5.20	4.46	3.71	2.97	2.23	1.49	0.74	0.00
306	6.00	5.14	4.29	3.43	2.57	1.72	0.86	0.00
346	6.75	5.79	4.82	3.86	2.89	1.93	0.96	0.00
406	7.50	6.43	5.36	4.28	3.21	2.14	1.07	0.00
168	2.60	2.08	1.56	1.04	0.52	0.00	–	–
198	2.80	2.24	1.68	1.12	0.56	0.00	–	–
218	3.00	2.40	1.80	1.20	0.60	0.00	–	–
258	3.50	2.80	2.10	1.40	0.70	0.00	–	–
308	4.00	3.20	2.40	1.60	0.80	0.00	–	–
348	4.50	3.60	2.70	1.80	0.90	0.00	–	–
408	5.00	4.00	3.00	2.00	1.00	0.00	–	–

Lamina couplings

RIGIFLEX®-N

RIGIFLEX®-HP

RIGIFLEX®-N

Steel lamina couplings

Technical data

Permissible speeds and stiffness									
Size	Max. speed [rpm]	each lamina set		ct [Nm/rad] for complete coupling with mounting length E					
		cw [Nm/rad]	ct x 10 ⁶ [Nm/rad]	E=100	E=140	E=180	E=200	E=250	
35	23000	170	0.056	65020	56700	-	-	-	
50	18000	490	0.27	73953	63990	-	-	-	
65	13600	260	0.5	146022	129938	117046	-	-	
75	12400	1000	0.67	306145	278381	255234	-	-	
85	11000	1500	0.9	-	406641	369429	353265	318433	
110	9000	1500	1.5	-	664284	637587	625028	595693	
120	8000	3000	2.0	-	1798018	1637553	1567602	1416348	
140	6400	10000	3.5	-	-	-	2363340	2226630	
160	5600	10350	6.9	-	-	-	-	2654894	
166	5600	26800	13.0	Mounting dimension E as specified by the customer					
196	5200	35800	17.0						
216	4600	41500	19.0						
256	3900	65000	31.0						
306	3300	112000	55.0						
346	2900	205000	79.0						
406	2500	276000	125.0						
168	5600	44300	20.0						
198	5200	82200	26.0						
218	4600	90000	30.0						
258	3900	138000	49.0						
308	3300	234000	83.0						
348	2900	416000	125.0						
408	2500	562000	200.0						

cw = angular stiffness
ct = torsion spring stiffness

Weights and mass moments of inertia													
Size	Hub (max. bore)		Spacer complete [kg]					Spacer complete [kgm ²]					
	[kg]	[kgm ²]	E=100	E=140	E=180	E=200	E=250	E=100	E=140	E=180	E=200	E=250	
35	0.60	0.0007	1.030	1.120	-	-	-	0.00040	0.00050	-	-	-	
50	0.92	0.001019	2.262	2.442	-	-	-	0.00256	0.00263	-	-	-	
65	2.7	0.00541	3.922	4.183	4.445	-	-	0.00810	0.00830	0.00828	-	-	
75	2.4	0.00566	4.482	4.842	5.202	-	-	0.01143	0.01191	0.01239	-	-	
85	3.7	0.01135	-	7.154	7.548	7.746	8.239	-	0.02364	0.02427	0.02459	0.02538	
110	6.7	0.03222	-	12.492	13.478	13.972	15.205	-	0.06291	0.06540	0.06665	0.06976	
120	9.2	0.05238	-	-	17.324	17.842	19.137	-	-	0.10314	0.10458	0.10818	
140	18.2	0.15175	-	-	-	32.530	34.325	-	-	-	0.31901	0.32845	
160	29.9	0.33890	-	-	-	-	52.458	-	-	-	-	0.68640	
166	28.0	0.32	Mounting dimension E as specified by the customer										
196	37.0	0.554											
216	50.0	0.85											
256	95.0	2.35											
306	138.0	4.55											
346	215.0	9.75											
406	310.0	18.95											
168	30.0	0.33											
198	40.0	0.56											
218	52.0	0.88											
258	99.0	2.43											
308	142.0	4.78											
348	222.0	9.83											
408	325.0	19.22											

RIGIFLEX®-N

Steel lamina couplings

Standard type A

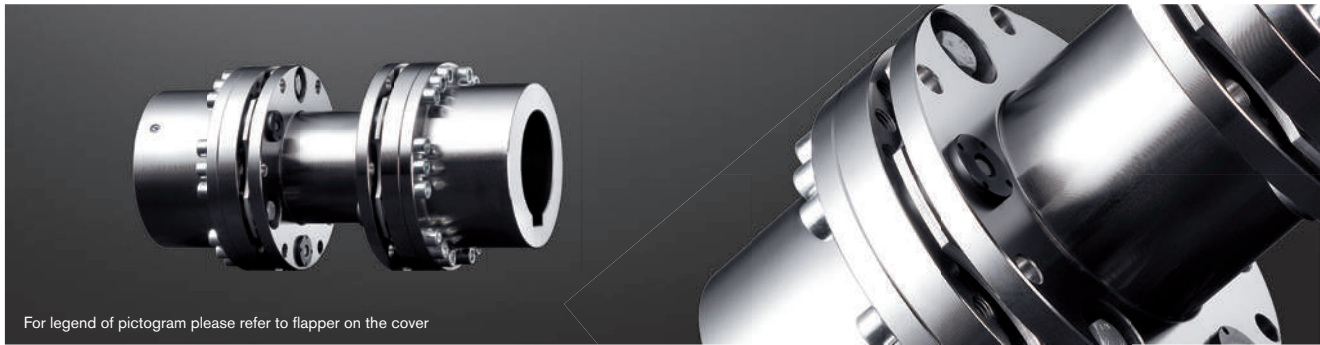

For legend of pictogram please refer to flapper on the cover

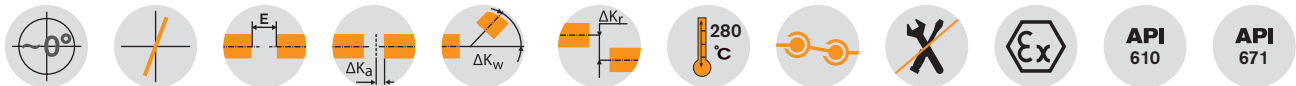

Components

Size 35

Size 50 - 408

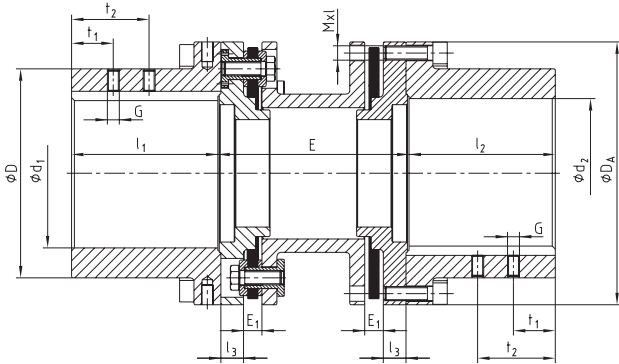
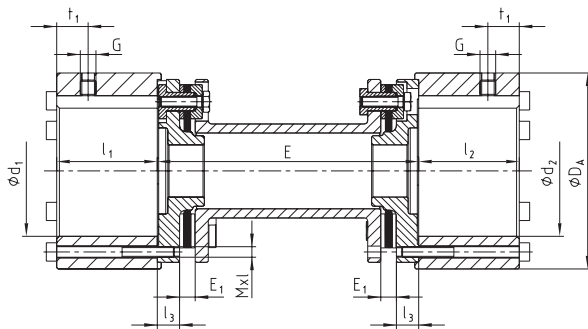

RIGIFLEX®-N type A

Size	Torques [Nm]			Max. finish bore d_1, d_2	Dimensions [mm]											Screws DIN EN ISO 4762			
	T_{KN}	$T_{K \max}$	T_{KW}		D	D_A	l_1, l_2	l_3	G	t_1	t_2	E_1	$E^{1)}$				Mxl	T_A [Nm]	
35	130	260	65	50	-	75	38.5	8.5	M6	15	-	6	100	140	-	-	-	M4x45	4.1
50	270	540	135	50	70	95	50	12	M6	10	-	9	100	140	-	-	-	M6x22	14
65	550	1100	275	70	100	126	63	12	M8	20	-	11	100	140	180	-	-	M6x25	14
75	1100	2200	550	75	105	138	62.5	12	M8	20	-	11	100	140	180	-	-	M8x30	35
85	1900	3800	950	90	120	156	72.5	15	M10	20	-	12	-	140	180	200	250	M8x30	35
110	3500	7000	1750	110	152	191	87	18	M10	25	-	12	-	140	180	200	250	M10x35	69
120	5750	11500	2875	120	165	213	102	20	M12	25	-	12	-	-	180	200	250	M12x40	120
140	10500	21000	5250	150	200	265	126	25	M12	30	-	15	-	-	-	200	250	M16x50	295
160	16000	32000	8000	165	230	305	145	31	M12	30	-	15	-	-	-	-	250	M16x55	295
166	19000	38000	9500	165	230	305	155	31	M16	30	70	17					M20x50	560	
196	22500	45000	11250	195	260	330	185	32	M16	40	90	24					M20x50	560	
216	32000	64000	16000	210	285	370	205	32	M20	50	110	26					M20x65	560	
256	52500	105000	26250	260	350	440	245	38	M20	70	130	31					M24x80	970	
306	86000	172000	43000	305	400	515	295	43	M24	70	130	36					M27x100	1450	
346	135000	270000	67500	350	460	590	335	55	M24	95	175	45					M30x110	1950	
406	210000	420000	105000	405	530	675	395	58.5	M24	95	175	50	According to customer specification				M36x130	3300	
168	25000	50000	12500	165	230	305	155	31	M16	30	70	17					M20x50	560	
198	30000	60000	15000	195	260	330	185	32	M16	40	90	24					M20x50	560	
218	42500	85000	21500	210	285	370	205	32	M20	50	110	26					M20x65	560	
258	70000	140000	35000	260	350	440	245	38	M20	70	130	31					M24x80	970	
308	115000	230000	57500	305	400	515	295	43	M24	70	130	36					M27x100	1450	
348	180000	360000	90000	350	460	590	335	55	M24	95	175	45					M30x110	1950	
408	280000	560000	140000	405	530	675	395	58.5	M24	95	175	50					M36x130	3300	

¹⁾ Other shaft distance dimensions available on request.
For selection of coupling see page 18 et seqq. Assembly instructions KTR standard 47410 available at www.ktr.com.

Ordering example:	RIGIFLEX®-N 120	A	Ø 100	Ø 120	200
	Coupling size	Type	Bore d_1	Bore d_2	Shaft distance dimension E

RIGIFLEX®-N

Steel lamina couplings

Standard type A-J

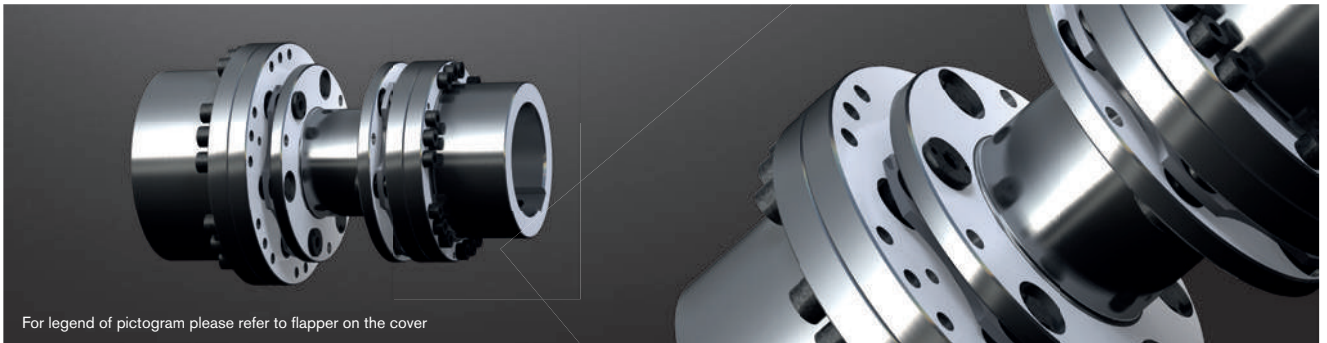

For legend of pictogram please refer to flapper on the cover



Components

Size 50 - 140

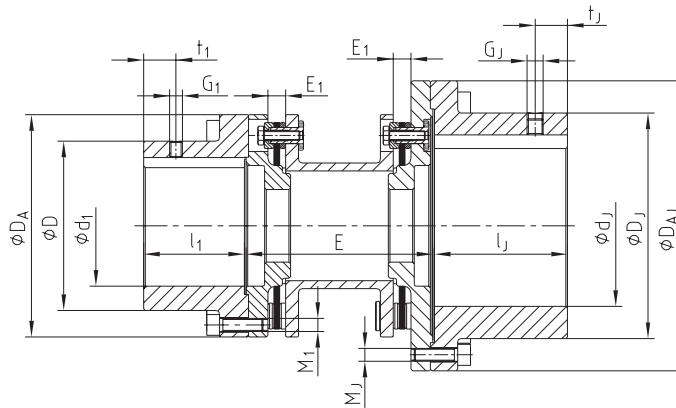

RIGIFLEX®-N type A-J																									
Size	Torques [Nm]			Max. finish bore		Dimensions [mm]														Screws DIN EN ISO 4762					
	TKN	TK max	TKW	d1	d2	D	DA	l1	DJ	DAJ	l2	G1	t1	G2	t2	E1	E ¹⁾				M1	TA [Nm]	M2	TA [Nm]	
50	270	540	135	50	70	70	95	50	100	126	63	M6	10	M8	20	9	100	140	-	-	-	M6	14	M6	14
65	550	1100	275	70	90	100	126	63	120	156	72.5	M8	20	M10	20	11	100	140	180	-	-	M6	14	M8	35
75	1100	2200	550	75	100	105	138	62.5	140	180	83	M8	20	M10	20	11	100	140	180	-	-	M8	35	M8	35
85	1900	3800	950	90	110	120	156	72.5	152	191	87.5	M10	20	M10	25	12	-	140	180	200	250	M8	35	M10	69
110	3500	7000	1750	110	150	152	191	87	200	265	127	M10	25	M12	30	12	-	140	180	200	250	M10	69	M16	295
120	5750	11500	2875	120	165	165	213	102	230	305	147	M12	25	M12	30	12	-	-	180	200	250	M12	120	M16	295
140	10500	21000	5250	150	195	200	265	126	260	330	186	M12	30	M16	40/90	15	-	-	-	200	250	M16	295	M20	560

¹⁾ Other shaft distance dimensions available on request.

For selection of coupling see page 18 et seqq. Assembly instructions KTR standard 47410 available at www.ktr.com.

Other types:

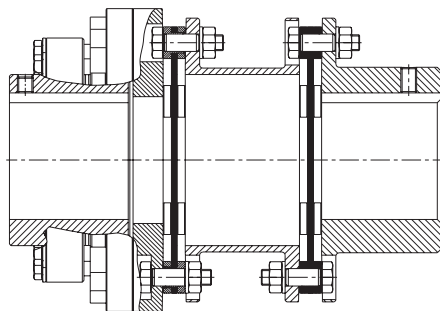

For RADEX®-N with integrated slipping unit see dimension sheet 699206

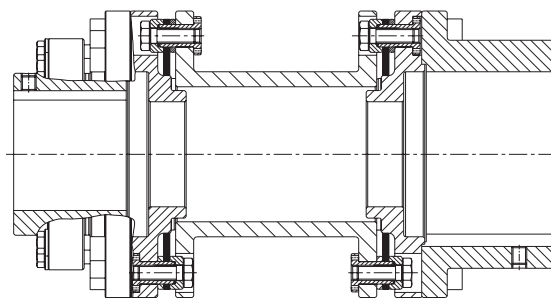

For RIGIFLEX®-N with integrated slipping unit see dimension sheet 698869

Ordering example:	RIGIFLEX®-N 85	A-J	Ø 80	Ø 120	200
	Coupling size	Type	Bore d ₁	Bore d ₂	Shaft distance dimension E

RIGIFLEX®-N

Steel lamina couplings

Standard type A-H

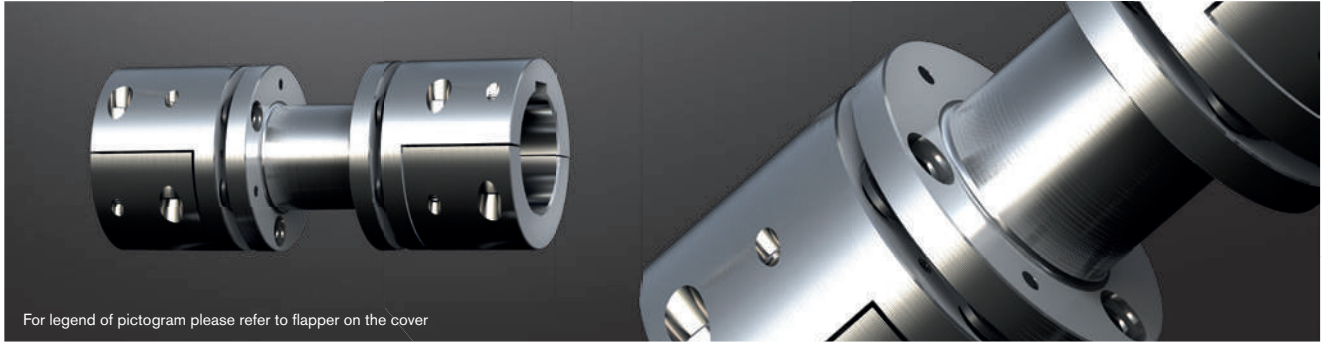

For legend of pictogram please refer to flapper on the cover

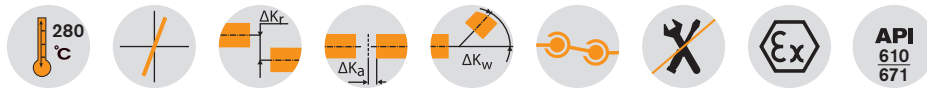

Components

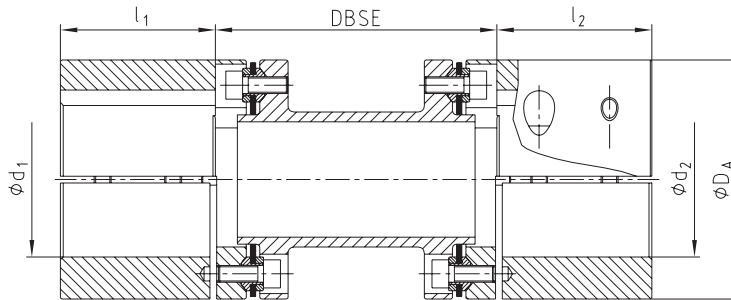

RIGIFLEX®-N type A-H											
Size	Torques [Nm]		Max. finish bore [mm]		Dimensions [mm]						
	T _{KN}	T _{K max}	d ₁ , d ₂	D _A	l ₁ , l ₂	Standard shaft distance dimension DBSE ¹⁾			Perm. axial displacement	Perm. angular displacement (each lamina set [°])	
46	90	180	42	69	45					+/- 1.4	1.0
56	255	510	55	85	55	100				+/- 1.2	0.7
66	450	900	65	105	65		140	180	250	+/- 1.6	0.7
76	975	1950	75	124	75					+/- 1.8	0.7
86	1500	3000	85	145	85	-				+/- 2.2	0.7
106	2400	4800	105	168	105					+/- 2.4	0.7

¹⁾ Other shaft distance dimensions (DBSE) available on request

Benefits of type A-H:

- Hub type 7.6 - half shell hub
- Easy and quick radial assembly and disassembly
- Type according to API 610 and 671 (please consider exceptions)
- Drop-out protection of spacer with fracture of laminae following API 671



Ordering example:

RIGIFLEX®-N 66	A-H	Ø 42	Ø 48	140
Coupling size	Type	Bore d ₁	Bore d ₂	Shaft distance dimension DBSE

RIGIFLEX®-HP C

High-performance steel lamina couplings

Flange connection

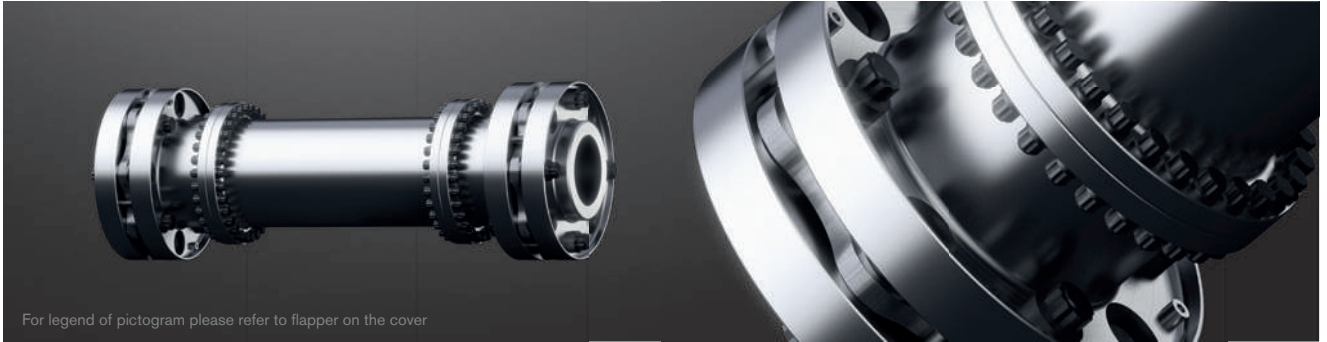

For legend of pictogram please refer to flapper on the cover



Components

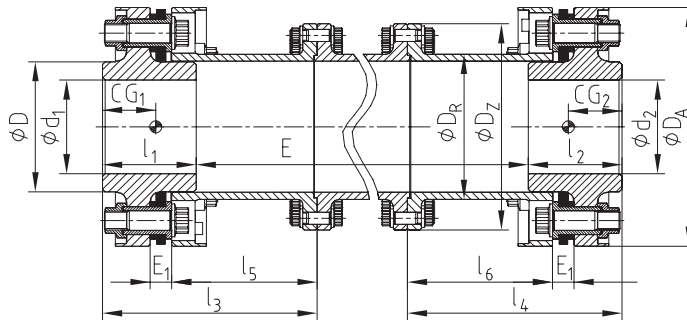

RIGIFLEX®-HP type C														
Size	Torques [Nm]		Max. finish bore	Dimensions [mm]										
	T _{KN}	T _{K max}		d ₁ , d ₂	D	D _A	D _Z	D _R	E ₁	E	E _{min.}	CG ₁ , CG ₂ ²⁾	l ₁ , l ₂	l ₃ , l ₄
158	20000	26000	85	119	220	195	135	17	According to customer specification	335	46	85	189	130
168	30000	39000	100	139	255	220	155	23		395	55	100	229	155
188	38000	49400	105	147	265	235	165	23		375	55	105	229	155
208	50000	65000	120	168	298	245	186	23		350	57	120	229	155
228	59000	76700	125	178	315	270	199	33		425	65	125	265	175
248	72000	93600	140	196	335	300	217	33		395	67	140	265	175
278	115000	149500	160	225	380	335	248	33		355	70	160	265	175
318	180000	234000	180	252	445	370	280	48		495	88	180	348	225
358	253000	328900	210	295	500	415	326	48		435	93	210	348	225
388	330000	429000	235	330	545	464	362	48		400	97	235	348	225

Technical data								
Size	Max. speed [rpm]	Perm. displacements			Stiffness figures			
		Angular ¹⁾ ± K _w [°]	Axial ± K _a [mm]	Radial ²⁾ ± K _r [mm]	each lamina set c _l [Nm/rad]	Spacer c _{lR} [Nm · mm/rad]	Coupling complete ²⁾ c _{lE} = 457.2 [Nm/rad]	
158	17300	0.25	3.0	2.30	13.0 · 10 ⁶	839 · 10 ⁶	1.04 · 10 ⁶	
168	14900	0.25	3.0	2.32	18.0 · 10 ⁶	1535 · 10 ⁶	1.79 · 10 ⁶	
188	14400	0.25	3.3	2.37	28.0 · 10 ⁶	1974 · 10 ⁶	2.23 · 10 ⁶	
208	12800	0.25	3.8	2.50	35.0 · 10 ⁶	2876 · 10 ⁶	3.15 · 10 ⁶	
228	12100	0.25	4.0	2.44	39.5 · 10 ⁶	4123 · 10 ⁶	5.06 · 10 ⁶	
248	11400	0.25	4.2	2.58	60.0 · 10 ⁶	5410 · 10 ⁶	5.51 · 10 ⁶	
278	10000	0.25	4.5	2.75	80.0 · 10 ⁶	8592 · 10 ⁶	7.94 · 10 ⁶	
318	8500	0.25	5.2	2.70	105.0 · 10 ⁶	14724 · 10 ⁶	13.00 · 10 ⁶	
358	7600	0.25	6.0	2.96	155.0 · 10 ⁶	26258 · 10 ⁶	20.30 · 10 ⁶	
388	7000	0.25	6.5	3.18	225.0 · 10 ⁶	37596 · 10 ⁶	27.70 · 10 ⁶	

¹⁾ Each lamina set ²⁾ with E=457.2 mm and cylindrical maximum finish bore

Size	Coupling ²⁾		Spacer	
	m [kg]	J [kgm ²]	m _R [kg/mm]	J _R [kgm ² /mm]
158	45	0.274	20.28 · 10 ⁻³	81 · 10 ⁻⁶
168	69	0.577	27.282 · 10 ⁻³	149 · 10 ⁻⁶
188	78	0.711	30.975 · 10 ⁻³	191 · 10 ⁻⁶
208	97	1.081	35.118 · 10 ⁻³	279 · 10 ⁻⁶
228	123	1.561	44.397 · 10 ⁻³	400 · 10 ⁻⁶
248	144	2.109	48.614 · 10 ⁻³	524 · 10 ⁻⁶
278	190	3.542	58.694 · 10 ⁻³	833 · 10 ⁻⁶
318	306	7.792	79.311 · 10 ⁻³	1427 · 10 ⁻⁶
358	405	12.869	104.041 · 10 ⁻³	2545 · 10 ⁻⁶
388	525	19.257	120.151 · 10 ⁻³	3644 · 10 ⁻⁶

$c_t \text{ total} = 1 / ((1/c_l E = 457.2) + ((E - 457.2 \text{ mm}) / c_{lR}))$
 $m_{\text{total}} = m + m_R \cdot (E - 457.2 \text{ mm})$
 $J_{\text{total}} = J + J_R \cdot (E - 457.2 \text{ mm})$

RIGIFLEX®-HP L

High-performance steel lamina couplings

Type with flange hubs

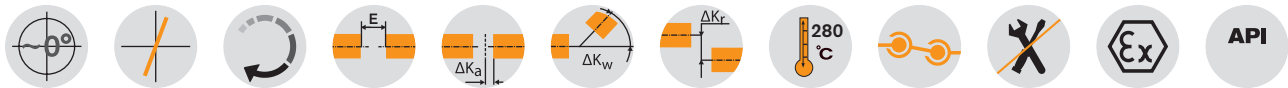

Components

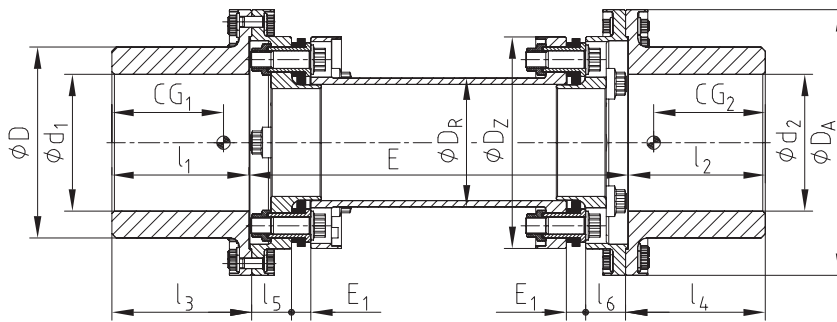

RIGIFLEX®-HP type L														
Size	Torques [Nm]		Max. finish bore	Dimensions [mm]										
	T _{KN}	T _{K max}		d ₁ , d ₂	D	D _A	D _Z	D _R	E ₁	E	E _{min}	CG ₁ , CG ₂ ²⁾	l ₁ , l ₂	l ₃ , l ₄
158	20000	26000	150	210	310	220	135	17	According to customer specification	265	140	150	163.5	37.5
168	30000	39000	165	230	320	255	155	23		340	148	165	168.5	48.0
188	38000	49400	180	250	335	265	165	23		340	156	180	183.5	48.0
208	50000	65000	200	280	362	298	186	23		340	165	200	203.5	48.0
228	59000	76700	220	310	390	315	199	33		390	179	220	223.5	54.5
248	72000	93600	240	340	420	334	217	33		390	185	235	238.5	54.5
278	115000	149500	270	380	455	380	248	33		390	202	270	273.5	54.5
318	180000	234000	315	445	550	445	280	48		510	246	315	318.5	71.5
358	253000	328900	350	490	600	500	326	48		510	263	350	353.5	71.5
388	330000	429000	380	535	650	545	362	48		510	277	380	383.5	71.5

Technical data								
Size	Max. speed [rpm]	Perm. displacements			Stiffness figures			
		Angular ¹⁾ ± K _w [°]	Axial ± K _a [mm]	Radial ²⁾ ± K _r [mm]	each lamina set		Coupling complete ²⁾	
					c _t [Nm/rad]	Spacer		c _{tE} = 457.2 [Nm/rad]
158	13800	0.25	3.0	1.56	13.0 · 10 ⁶	839 · 10 ⁶		1.70 · 10 ⁶
168	12300	0.25	3.0	1.45	18.0 · 10 ⁶	1535 · 10 ⁶		3.00 · 10 ⁶
188	11400	0.25	3.3	1.45	28.0 · 10 ⁶	1974 · 10 ⁶		4.08 · 10 ⁶
208	10500	0.25	3.8	1.45	35.0 · 10 ⁶	2876 · 10 ⁶		5.61 · 10 ⁶
228	9700	0.25	4.0	1.34	39.5 · 10 ⁶	4123 · 10 ⁶		7.77 · 10 ⁶
248	9000	0.25	4.2	1.34	60.0 · 10 ⁶	5410 · 10 ⁶		10.70 · 10 ⁶
278	8300	0.25	4.5	1.34	80.0 · 10 ⁶	8592 · 10 ⁶		15.60 · 10 ⁶
318	6900	0.25	5.2	1.13	105.0 · 10 ⁶	14724 · 10 ⁶		26.90 · 10 ⁶
358	6300	0.25	6.0	1.13	155.0 · 10 ⁶	26258 · 10 ⁶		41.20 · 10 ⁶
388	5800	0.25	6.5	1.13	225.0 · 10 ⁶	37596 · 10 ⁶		61.30 · 10 ⁶

¹⁾ Each lamina set ²⁾ with E=457.2 mm and cylindrical maximum finish bore

Size	Coupling ²⁾		Spacer	
	m [kg]	J [kgm ²]	m _R [kg/mm]	J _R [kgm ² /mm]
158	80	0.717	20.28 · 10 ⁻³	81 · 10 ⁻⁶
168	115	1.327	27.282 · 10 ⁻³	149 · 10 ⁻⁶
188	135	1.759	30.975 · 10 ⁻³	191 · 10 ⁻⁶
208	175	2.771	35.118 · 10 ⁻³	279 · 10 ⁻⁶
228	235	4.525	44.397 · 10 ⁻³	400 · 10 ⁻⁶
248	285	6.417	48.614 · 10 ⁻³	524 · 10 ⁻⁶
278	375	10.381	58.694 · 10 ⁻³	833 · 10 ⁻⁶
318	642	24.810	79.311 · 10 ⁻³	1427 · 10 ⁻⁶
358	812	38.404	104.041 · 10 ⁻³	2545 · 10 ⁻⁶
388	1016	57.062	120.151 · 10 ⁻³	3644 · 10 ⁻⁶

Ordering example:	RIGIFLEX®-HP 188	L	Ø 160	Ø 180	457.2
	Coupling size	Type	Bore d ₁	Bore d ₂	Shaft distance dimension E



Flange couplings

Types and operating description 202

BoWex®	
BoWex® FLE-PA	204
BoWex® FLE-PAC	206
Selection according to SAE standard	208
Mounting dimensions according to SAE standard	209
Programme of special flanges deviating from SAE standard	210
Flange couplings in KUBOTA engines	212
Flange couplings in Perkins engines	213
Flange couplings in DEUTZ engines	214



MONOLASTIC®	
Type with 3 holes	216
SAE type	217
Examples of application	218



BoWex-ELASTIC®	
Type HE1 - HE4	220
Type HE3, HE4 and HE-D	222
Type HE-ZS and HEW	224
Type HEG	226



Please note: torque increase



Years of experience with applications at customer sites and additional test series in the KTR test field in Rheine enabled us to determine potentials allowing for an increase of rated torques with some sizes of this series.

BoWex® FLE-PA



BoWex® FLE-PAC



MONOLASTIC®



BoWex-ELASTIC®



FLANGE COUPLINGS

TYPES AND OPERATING DESCRIPTION

Properties of flange couplings

			
Product	BoWex® FLE-PA/-PAC	MONOLASTIC®	BoWex-ELASTIC®
Type	Torsionally rigid flange coupling	Flexible flange coupling	Highly flexible flange coupling
Features			
Torsionally rigid	●		
Torsionally flexible		●	
Highly flexible			●
Damping vibrations		●	●
Maintenance-free	●	●	●
Axial plug-in	●	●	●
Special features/applications			
Variant diversity	very high	high	very high
Flange dimension	SAE standard and special dimensions	type 3/4 hole, SAE standard, special dimensions	SAE standard and special dimensions
Internal spline	see standard programme of BoWex® hubs	for SAE or DIN pump shafts	see standard programme of BoWex® hubs
Applications	hydrostatic drives of construction machines, agricultural machines, ...	hydrostatic drives of construction machines, agricultural machines, ...	generators, splitterboxes, water pumps, piston compressors, agricultural machines, gensets, mill drives, separator drives, ...
Performance data			
Max. rated torque T_{KN} [Nm]	6,600	1,850	70,000
Max. speed n [rpm]	6,000	6,000	6,200
Flange (standard and special)			
Material	fibre-glass reinforced Polyamide (PA)	natural rubber	natural rubber
	combination of polyamide with carbon fibre share and steel flange (PAC)		
Elastomer hardness	torsionally rigid	65, 70 Shore A	"various kinds of hardness for vibration adaptation of drives"
Flange (standard)			
Temperature range [°C] min./max.	-25/+130 (PA)	-40/+90	-40/+90
	-25/+130 (PAC)		
Motor power [kW]			
Max.	800	250	5,000

- ≈ Standard
- ≈ On request
- * ≈ Depending on size

FLANGE COUPLINGS

TYPES AND OPERATING DESCRIPTION

Product finder of flange couplings

Product	BoWex® FLE-PA/-PAC	MONOLASTIC®	BoWex-ELASTIC®
Type	Torsionally rigid flange coupling	Flexible flange coupling	Highly flexible flange coupling
Geometries			
Design	extremely short	short	short
Max. radial displacement	0.5 mm	1 mm	9.5
Shaft diameter min./max. [mm]	20 / 125	20/60	21 / 275
Types (extract)			
Intermediate shaft types » bridging larger shaft distances	-	-	HE-ZS
Shaft-to-shaft connection	-	-	HEW 1 and 2, HEW-ZS
Flange-to-shaft connection	Standard	Standard	HE 1, 2, 3, and 4, HE-ZS
For cardan shafts » Connecting couplings for I. C.-engines	-	-	HEG 1 and 2
Combination with pump mounting flange	●	●	●
Certifications/type examinations			
ATEX 			●
Bureau Veritas 	●		●
DNV/GL 			●
GOST R/ GOST TR 	●	●	●

● ≈ Standard

Please note: Pump mounting flanges



For connecting hydraulic pumps to the diesel engine KTR supplies mounting flanges according to SAE connection dimensions sizes SAE 6 to SAE 1. These flanges are made of steel and EN-GJL-250 (GG25) for hydraulic pumps with flange connections according to SAE-A, -B, -C, -D and -E as types with 2 and 4 holes.

Pump connection housings made of EN-GJL-250 (GG 25) to be mounted directly to the back plate of the engine.

BoWex® FLE-PA

Torsionally rigid flange couplings

Axial plug-in, maintenance-free, torsionally rigid

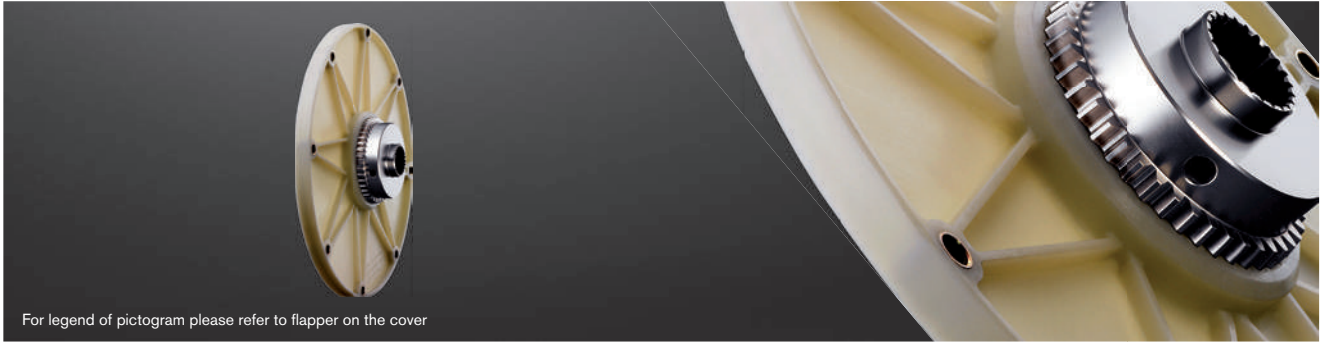

For legend of pictogram please refer to flapper on the cover

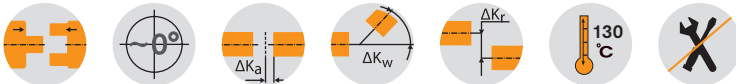

BoWex® FLE-PA – Dimensions/nominal dimension acc. to SAE																			
Size	Pilot bore	Finish bore d		Dimensions [mm]								Special length l1 max.	Nominal size acc. to SAE (Dg)						Max. axial displacement [mm]
		Min.	Max.	D	D1	l1	l3	l7	l8	l10	l11		6 1/2"	7 1/2"	8"	10"	11 1/2"	14"	
48	-	20	48	68	100	50	41	50	20	13	48	up to 60	●	●	●	●			± 2
T 48	13	15	48	68	100	50	38	45	20	13	46	-	●	●	●	●			± 1
T 55	17	20	55	85	115	50	37	48	24	13	48	-	●	●	●	●			± 2
65 / T 65	21	30	65	96	132	55	45	54	27	21	51	up to 70			●	●	●		± 2
T 70	26	30	70	100	153	60	48	56	30	21	57	-				●			± 2
80 / T 80	31	35	90	124	170	90	78	87	30	21	87	-				●	●		± 2
100 / T 100	38	40	100	152	265	110	78	108	35	21	110	-					●	●	± 2
125 / T 125	45	50	125	192	250	140	113	140	50	28	97	-					●	●	± 2

Special flange dimension see page 204 - 207 and on request

Technical data of BoWex® FLE-PA – Torques/weights/mass moments of inertia/torsion spring stiffness																
Size	Torque TK [Nm]			Weight/mass moment of inertia J	Hub with max. bore	FLE-PA flanges according to SAE						Dynamic torsion spring stiffness with +60 °C/ψ = 0.4 [Nm/rad]				
	TKN	TK max	TKW			6 1/2"	7 1/2"	8"	10"	11 1/2"	14"	0.30 TKN	0.50 TKN	0.75 TKN	1.00 TKN	
48	240	600	120	[kg]	0.79	0.32	0.43	0.51	0.64	-	-	35 x 10³	75 x 10³	105 x 10³	125 x 10³	
				[kgm²]	0.0007	0.0021	0.0035	0.0049	0.0085	-	-					
T 48	300	750	150	[kg]	0.79	0.32	0.43	0.51	0.64	-	-	40 x 10³	86 x 10³	120 x 10³	143 x 10³	
				[kgm²]	0.0007	0.0021	0.0035	0.0049	0.0085	-	-					
T 55	450	1125	225	[kg]	1.20	0.34	0.62	0.45	0.646	-	-	90 x 10³	140 x 10³	170 x 10³	195 x 10³	
				[kgm²]	0.0016	0.0022	0.0053	0.0044	0.0086	-	-					
65	650	1600	325	[kg]	1.50	-	-	0.63	0.64	0.89	-	110 x 10³	160 x 10³	200 x 10³	230 x 10³	
				[kgm²]	0.0027	-	-	0.0064	0.0065	0.012	-					
T 65	800	2000	400	[kg]	1.60	-	-	0.63	0.64	0.89	-	130 x 10³	190 x 10³	240 x 10³	280 x 10³	
				[kgm²]	0.0035	-	-	0.0064	0.0065	0.012	-					
T 70	1000	2500	500	[kg]	2.60	-	-	-	0.941	-	-	165 x 10³	315 x 10³	345 x 10³	368 x 10³	
				[kgm²]	0.0059	-	-	-	0.0132	-	-					
80	1200	3000	600	[kg]	5.20	-	-	-	1.05	1.12	-	200 x 10³	410 x 10³	580 x 10³	700 x 10³	
				[kgm²]	0.0151	-	-	-	0.015	0.022	-					
T 80	1500	3750	750	[kg]	5.20	-	-	-	1.05	1.12	-	240 x 10³	450 x 10³	638 x 10³	770 x 10³	
				[kgm²]	0.0151	-	-	-	0.015	0.022	-					
100	2050	5150	1025	[kg]	9.37	-	-	-	-	1.16	8.45	500 x 10³	700 x 10³	856 x 10³	950 x 10³	
				[kgm²]	0.0401	-	-	-	-	0.021	0.234					
T 100	2500	6250	1250	[kg]	9.37	-	-	-	-	1.16	8.45	600 x 10³	830 x 10³	960 x 10³	1070 x 10³	
				[kgm²]	0.0401	-	-	-	-	0.021	0.234					
125	4250	10700	2125	[kg]	19.73	-	-	-	-	2.09	9.85	1280 x 10³	1885 x 10³	2280 x 10³	2665 x 10³	
				[kgm²]	0.1359	-	-	-	-	0.043	0.306					
T 125	5300	13250	2650	[kg]	19.73	-	-	-	-	2.09	9.85	1600 x 10³	2250 x 10³	2700 x 10³	3200 x 10³	
				[kgm²]	0.1359	-	-	-	-	0.043	0.306					

Mounting short version

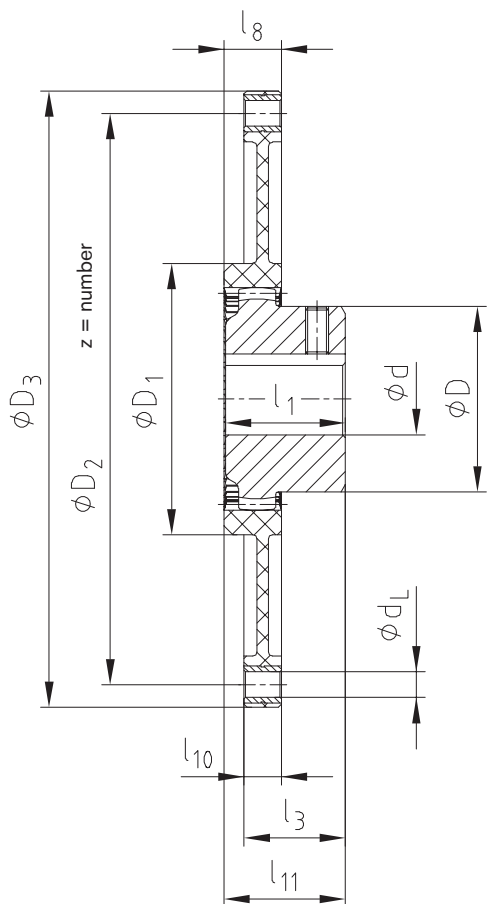

Mounting long version

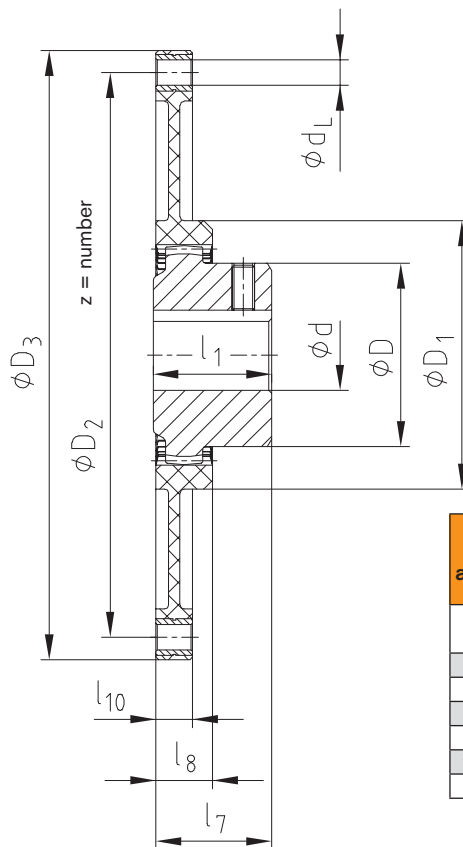

Flange dimensions according to SAE J620 [mm]				
Size	D ₃	D ₂	z	d _L
6 1/2"	215.9	200.02	6	9
7 1/2"	241.3	222.25	8	9
8"	263.52	244.47	6	11
10"	314.32	295.27	8	11
11 1/2"	352.42	333.37	8	11
14"	466.72	438.15	8	13

Example of installation

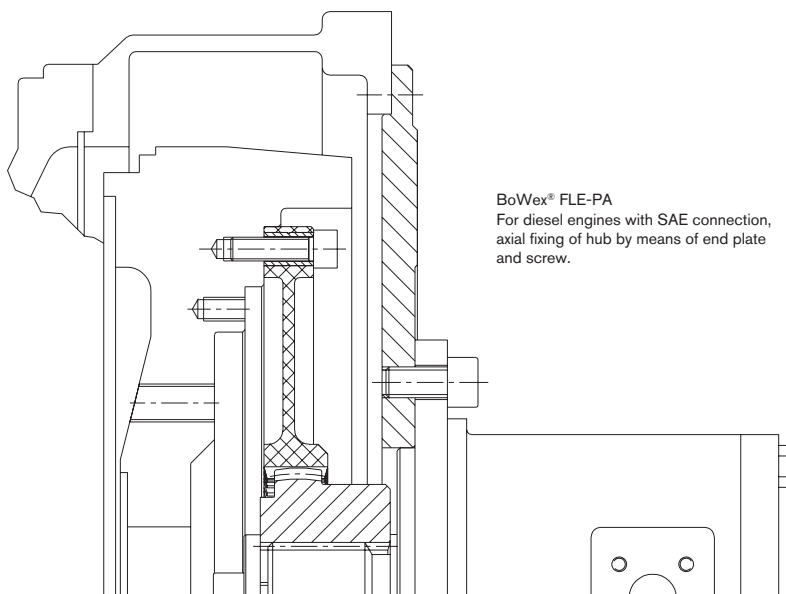

BoWex® FLE-PA
For diesel engines with SAE connection,
axial fixing of hub by means of end plate
and screw.

BoWex® FLE-PAC

Torsionally rigid flange couplings

Axial plug-in, extremely short design, carbon-fibre reinforced material

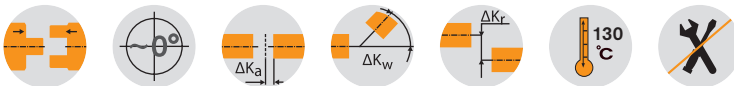
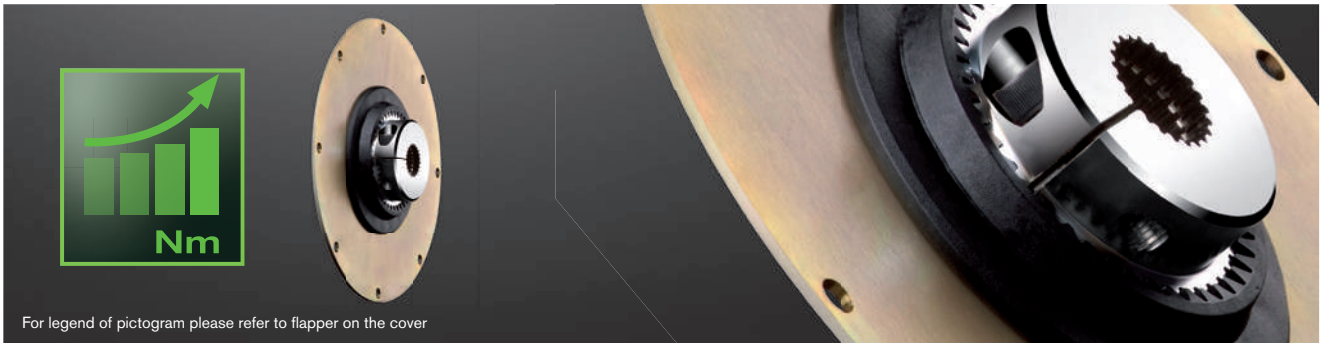

BoWex® FLE-PAC – Dimensions/nominal dimension to SAE

Size	Pilot bore	Finish bore d		Dimensions [mm]							Special length l ₁ max.	Nominal size acc. to SAE (D ₃)						Max. axial displacement [mm]
		Min.	Max.	D	D ₁	l ₁	l ₃	l ₇	l ₈	l ₁₀		6 1/2"	7 1/2"	8"	10"	11 1/2"	14"	
48 / T 48	13	15	48	68	110	50	35	46	25	3	up to 60	●	●	●	●		± 3	
T 55	17	20	55	85	148	50	32	42	28	3	-	●	●	●	●		± 3	
65 / T 65	21	30	65	96	165	55	36	46	32	4	up to 70	●	●	●	●	●	± 3	
80 / T 80	31	35	90	124	220	90	72	76	35	4	-				●	●	± 3	
100 / T 100	38	40	100	152	280	110	85	102	47	5	-				●	●	± 3	
125 / T 125	45	50	125	192	250	140	113	140	50	28	-				●	●	± 3	

Special flange dimensions deviating from SAE standard are also available.

Technical data of BoWex® FLE-PAC – Torques/weights/mass moments of inertia/torsion spring stiffness

Size	Torque T _K [Nm]			Weight/mass moment of inertia J	Hub with max. bore	FLE-PAC flanges according to SAE						Dynamic torsion spring stiffness with +60 °C/ψ = 0.45 [Nm/rad]					
	T _{KN}	T _{K max}	T _{KW}			6 1/2"	7 1/2"	8"	10"	11 1/2"	14"	0.30 T _{KN}	0.50 T _{KN}	0.75 T _{KN}	1.00 T _{KN}		
48	300	600	150	[kg]	0.79	0.77	0.98	1.19	1.73								
				[kgm ²]	0.0007	0.0049	0.0077	0.0109	0.0221				64 x 10 ³	95 x 10 ³	114 x 10 ³	132 x 10 ³	
T 48	370	740	185	[kg]	0.79	0.77	0.98	1.19	1.73								
				[kgm ²]	0.0007	0.0049	0.0077	0.0109	0.0221				91 x 10 ³	129 x 10 ³	155 x 10 ³	182 x 10 ³	
T 55	550	1100	275	[kg]	1.20	0.74	0.95	1.16	1.7								
				[kgm ²]	0.0016	0.0049	0.0077	0.0109	0.0222				181 x 10 ³	258 x 10 ³	312 x 10 ³	358 x 10 ³	
65	800	1600	400	[kg]	1.50	0.93	1.2	1.48	2.20	2.83							
				[kgm ²]	0.0027	0.0065	0.0101	0.0145	0.0294	0.0467			214 x 10 ³	329 x 10 ³	397 x 10 ³	451 x 10 ³	
T 65	1000	2000	500	[kg]	1.60	0.93	1.2	1.48	2.20	2.83							
				[kgm ²]	0.0035	0.0065	0.0101	0.0145	0.0294	0.0467			256 x 10 ³	381 x 10 ³	461 x 10 ³	516 x 10 ³	
80	1500	3000	750	[kg]	5.20				2.27	2.90	5.20						
				[kgm ²]	0.0151				0.0312	0.0485	0.1462	486 x 10 ³	713 x 10 ³	923 x 10 ³	1156 x 10 ³		
T 80	1850	3700	925	[kg]	5.20				2.27	2.90	5.20						
				[kgm ²]	0.0151				0.0312	0.0485	0.1462	556 x 10 ³	815 x 10 ³	1065 x 10 ³	1329 x 10 ³		
100	2550	5100	1275	[kg]	9.37						3.35	6.22					
				[kgm ²]	0.0401						0.0606	0.1828	679 x 10 ³	929 x 10 ³	1218 x 10 ³	1457 x 10 ³	
T 100	3100	6200	1550	[kg]	9.37						3.35	6.22					
				[kgm ²]	0.0401						0.0606	0.1828	767 x 10 ³	1030 x 10 ³	1343 x 10 ³	1594 x 10 ³	
125	5350	10700	2675	[kg]	19.73						2.09	9.85					
				[kgm ²]	0.1359						0.0606	0.1828	1538 x 10 ³	2098 x 10 ³	2528 x 10 ³	2980 x 10 ³	
T 125	6600	13200	3300	[kg]	19.73						2.09	9.85					
				[kgm ²]	0.1359						0.043	0.306	1887 x 10 ³	2495 x 10 ³	3035 x 10 ³	3629 x 10 ³	

■ = Years of experience with applications at customer sites and additional test series in the KTR test field in Rheine enabled us to determine potentials allowing for an increase of the rated torques with some sizes of this series.

Mounting short version

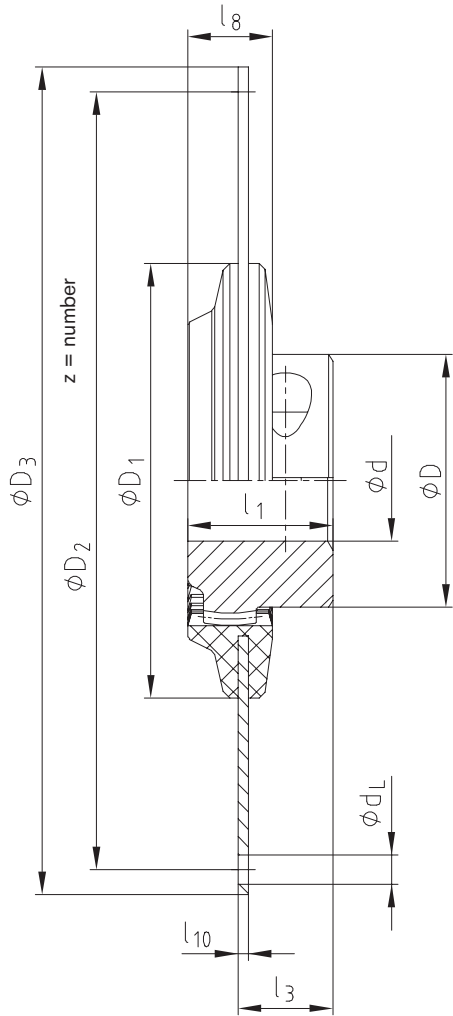

Mounting long version

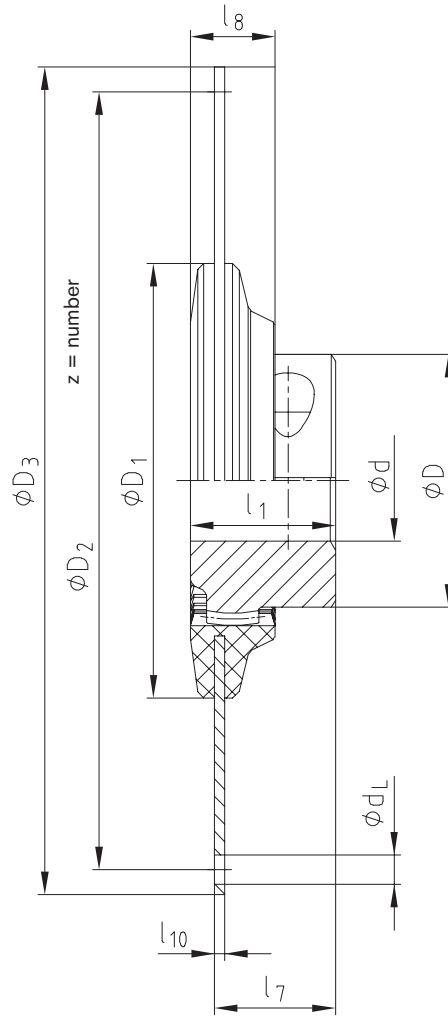

Flange dimensions according to SAE J620 [mm]				
Size	D ₃	D ₂	z	d _L
6 1/2"	215.9	200.02	6	9
7 1/2"	241.3	222.25	8	9
8"	263.52	244.47	6	11
10"	314.32	295.27	8	11
11 1/2"	352.42	333.37	8	11
14"	466.72	438.15	8	14

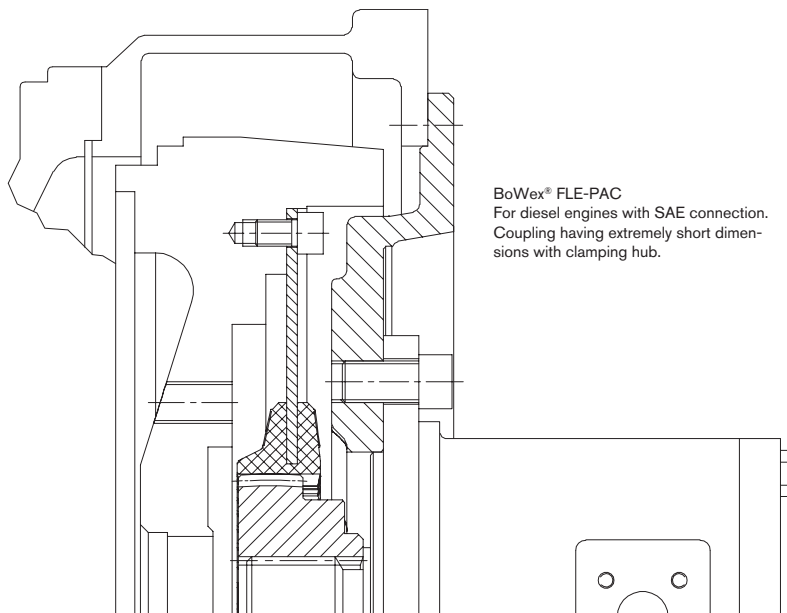

BoWex® FLE-PA / FLE-PAC

Torsionally rigid flange couplings

Selection according to SAE standard

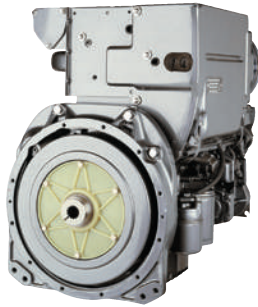

Determination of coupling

- Determination of coupling size
- Connection dimension of coupling
- Hub design/mounting length

- Table 1
- Table 2
- Table 3

SAE pump mounting flange

- Flange size according to SAE 617
- Connection flange of hydraulic pump

- Table 4
- Table 5

Short mounting version of coupling (l₃)

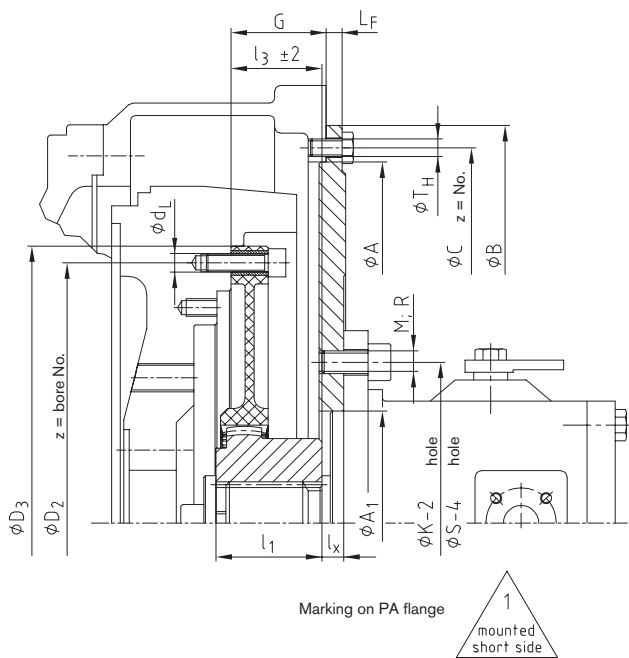

Long mounting version of coupling (l₇)

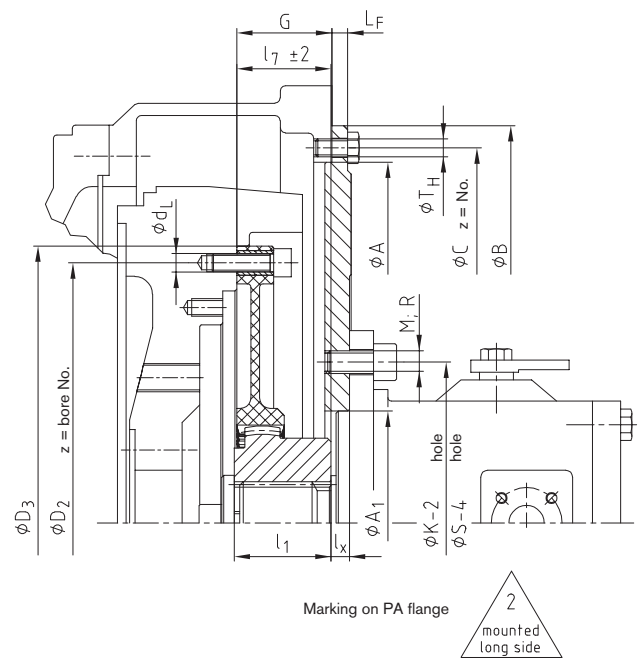

Spline hub

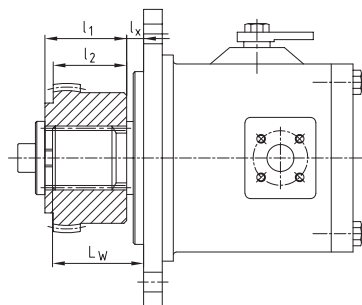

Clamping hub

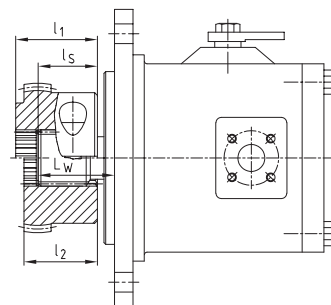

Determination of mounting length l₃ or l₇

SAE shaft	$l_3 / l_7 = G + LF - LW + l_s$
DIN shaft	$l_3 / l_7 = G + LF - l_x$

If axial fixing of the hub by means of an end plate and a screw is not possible for a pump shaft with involute spline, we would recommend to use a clamping hub.

Mounting instructions:

The flange can be fastened to the engine flywheel by means of socket head cap screws according to DIN EN ISO 4762 quality 8.8 or by hexagon head screws quality 8.8. We recommend screws are loctited in position.

Screw tightening torque of FLE-PA flange on the flywheel

M8	25 Nm
M10	49 Nm
M12	86 Nm

Screw tightening torque of spline clamping hubs DIN EN ISO 4762

42/48	M10	49 Nm
T55/65/T70	M12	86 Nm
80/100/125	M16	210 Nm

BoWex® FLE-PA / FLE-PAC

Torsionally rigid flange couplings

Mounting dimensions according to SAE standard

1. Selection of coupling for diesel engine									
⊗	Diesel engine power		Coupling size	Flywheel to SAE			Pump mounting flange		Driving shaft of pump
	kW	HP		G			LF		
up to 30 kW	up to 40 PS	48 FLE-PA	6 1/2"	30.15	1.19"	For dimensions to SAE see tables 3 and 4	9.5	0.375"	See Table 3 hub design SAE J 498 / DIN 5480
			7 1/2"	30.15	1.19"				
			8"	62	2.44"				
up to 90 kW	up to 120 PS	65 FLE-PA	8"	54	2.12"				
			10"	54	2.12"				
			11 1/2"	39.6	1.56"				
up to 180 kW	up to 240 PS	80 FLE-PA	11 1/2"	39.6	1.56"				

2. Dimensions of coupling flange according to SAE J620 [mm]					
⊗	Nominal size	D ₃	D ₂	z = number	d _L
	6 1/2"	215.90	200.02	6	9
	7 1/2"	241.30	222.25	8	9
	8"	263.52	244.47	6	11
	10"	314.32	295.27	8	11
	11 1/2"	352.42	333.37	8	11
	14"	466.72	438.15	8	14

3. Selection of coupling hubs - Determination of mounting length l ₃ or l ₇															
BoWex® coupling size	Pump shaft to SAE J 498 and DIN 5480	Spline hub	Spline clamping hub	Dimensions of coupling hub [mm]			Mounting length of coupling l ₃ or l ₇								Code to order coupling hub Specify coupling size
				l ₁	l ₂	l _S	Flange size 6 1/2" and 7 1/2"		Flange size 8"		Flange size 10"		Flange size 11 1/2"		
							K	L	K	L	K	L	K	L	
42	SAE-16/32 DP	x	x	42	-	33	33	42							P559101
	PI-S 3/4" z = 11														
42	SAE-16/32 DP	x	x	42	-	-	33	42							P567101
	PB-S 7/8" z = 13														
42	SAE-16/32 DP	x	x	42	-	27	33	42							P660201
	PB-BS 1" z = 15														
48	SAE-16/32 DP	x	x	50	-	45	41	50	50	41	50				P663301
65	PA-S 1 3/8" z = 21	x	x	50	-	48			54	45	54	41			P663301
65	SAE-12/24 DP	x	x	55	-	44			54	45	54	41			P656201
	PC-S 1 1/4" z = 14														
65	SAE-16/32 DP	x	x	-	49	45					53	41			P664301
	PD-S 1 1/2" z = 23														
80	SAE-16/32 DP	x	x	55	-	-						33	44		P565402
	PE-S 1 3/4" z = 27														
42	25 x 1.25 x 18 DIN 5480	x	x	42	-	-	33	42							P000205
42		x	x	42	-	-	33	42							P500202
42	30 x 2 x 14 DIN 5480	x	x	42	-	-	33	42							P500203
48		x	x	50	-	-	41	50							P000206
48	35 x 2 x 16 DIN 5480	x	x	50	-	-	41	50	50		50				P500203
48		x	x	46	-	-	37	46							P000303
65	40 x 2 x 18 DIN 5480	x	x	55	-	-					54	39			P000303
65		x	x	60	-	-			50	59	50	59	39		P500301
65	40 x 2 x 18 DIN 5480	x	x	55	-	-					54	39			P000304
65		x	x	55	-	-			54	45	54	39			P500302
65	45 x 2 x 21 DIN 5480	x	x	-	64	-			60	69	60	69	39		P000403
65		x	x	55	-	-			54	45	54	39			P500401
80	50 x 2 x 24 DIN 5480	x	x	55	-	-						37	42		P500405

4. Housing dimensions according to SAE 617 [mm]							
⊗	SAE size	A	B	C	Z	TH	
	SAE-1	511.18	552	530.2	12	M10	3/8"
	SAE-2	447.68	489	466.7	12	M10	3/8"
	SAE-3	409.58	451	428.6	12	M10	3/8"
	SAE-4	361.95	403	381.0	12	M10	3/8"
	SAE-5	314.33	356	333.4	8	M10	3/8"

5. Mounting flange for hydraulic pump acc. to SAE [mm]											
⊗	SAE size	SAE flange with 2 holes					SAE flange with 4 holes				
		A ₁	K-2	M	Z	A ₁	S-4	R	Z		
	A	82.55	106.4	M10	3/8"	2	82.55	104.6	M10	3/8"	4
	B	101.6	146.0	M12	1/2"	2	101.6	127.0	M12	1/2"	4
	C	127.0	181.0	M16	5/8"	2	127.0	162.0	M12	1/2"	4
	D	152.4	228.6	M16	5/8"	2	152.4	228.6	M16	5/8"	4
	E	-	-	-	-	-	165.1	317.5	M20	3/4"	4

Ordering example: Coupling FLE-PA/FLE-PAC			SAE pump mounting flange	
BoWex® 48 FLE-PA	7 1/2"	P663301	SAE-4	B-2L
Coupling size	SAE connection of coupling	Code of coupling hub	Pump mounting flange for engine housing	Pump flange to SAE 2 holes/4 holes standard metric fastening thread
Table 1	Table 2	Table 3	Table 4	Table 5

BoWex® FLE-PA Torsionally rigid flange couplings

Special flange programme, deviations from the SAE standard

Fitting to
diesel engines:
Hatz

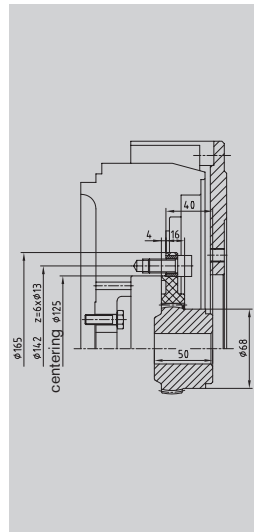

BoWex® 48 FLE-PA, Ø165
Hatz
2L/3L/4L41C 2M/3M/4M41
4M42,4L42C

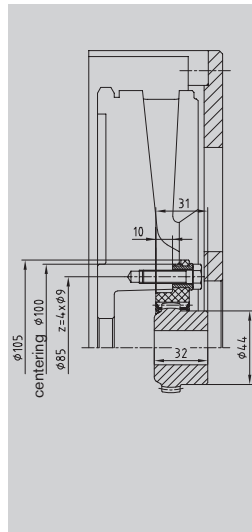

BoWex® 28 FLE-PA, Ø105
Hatz
1D81 / 1D90

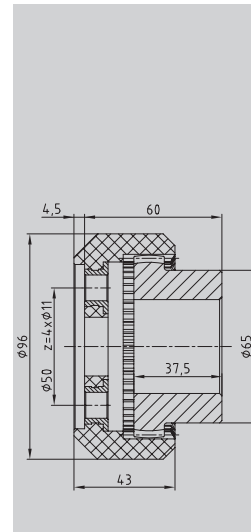

BoWex® 48 FLE-PA, Ø96
Hatz
Z788 / Z789 / Z790

Coupling size

Engine type

Fitting to
diesel engines:
VW
Mitsubishi

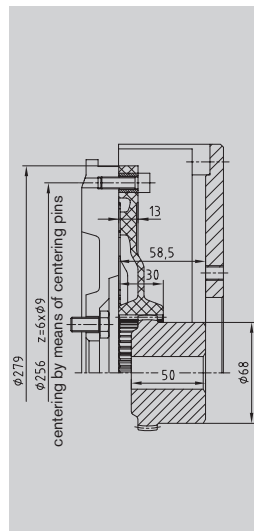

BoWex® 48 FLE-PA, Ø279
VW
028.B / M344

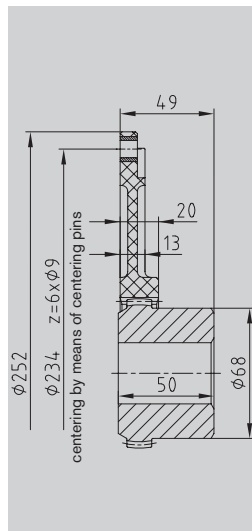

BoWex® 48 FLE-PA, Ø252
VW
062.2 / 068.5 / 6 / A / D

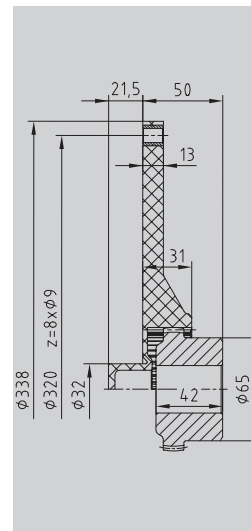

BoWex® 48 FLE-PA
Mitsubishi
Ø338-32

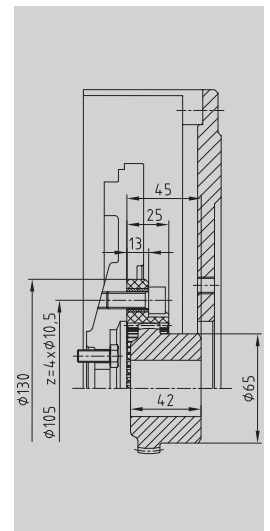

BoWex® 48 FLE-PA, Ø130
Mitsubishi
Series L / Series K

Coupling size

Engine type

Fitting to
diesel engines:
Perkins
Lombardini

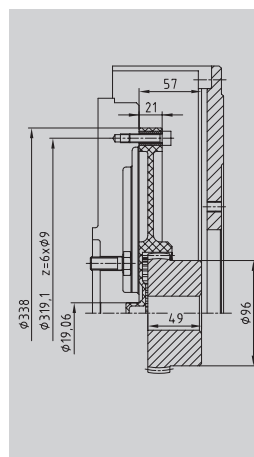

BoWex® 65 FLE-PA, Ø338
Perkins 1104C-44T
Flywheel No. D0014

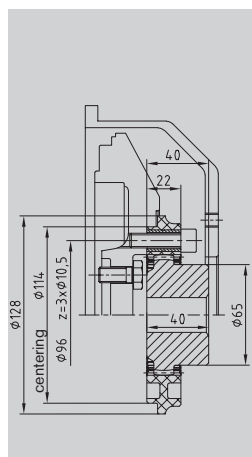

BoWex® 48 FLE-PA, Ø128
Lombardini
FOCS series

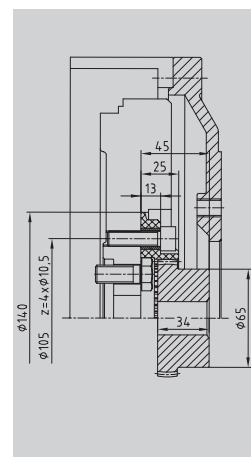

BoWex® 48 FLE-PA, Ø140
Lombardini
LDW

Coupling size

Engine type

BoWex® FLE-PA

Torsionally rigid flange couplings

Special flange programme, deviations from the SAE standard

Fitting to diesel engines:
Perkins
Isuzu
Cummins

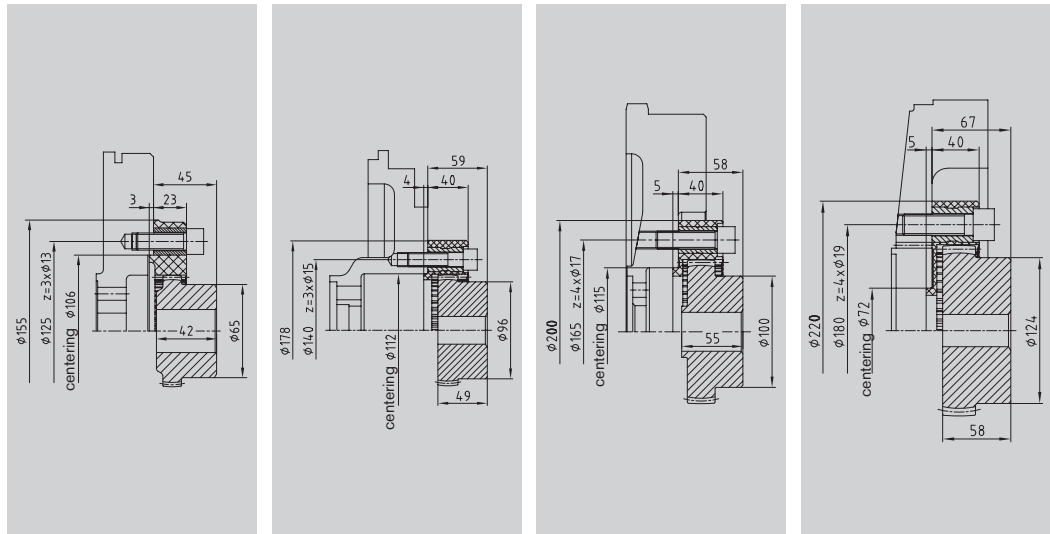

Coupling size
Engine type

BoWex® 48 FLE-PA,
Ø155
3 holes, Ø125

BoWex® 65 FLE-PA,
Ø178
3 holes, Ø140

BoWex® 70 FLE-PA,
Ø200
4 holes, Ø165

BoWex® 80 FLE-PA,
Ø220
4 holes, Ø180

Fitting to diesel engines:
Caterpillar
Daimler
Cummins
John-Deere

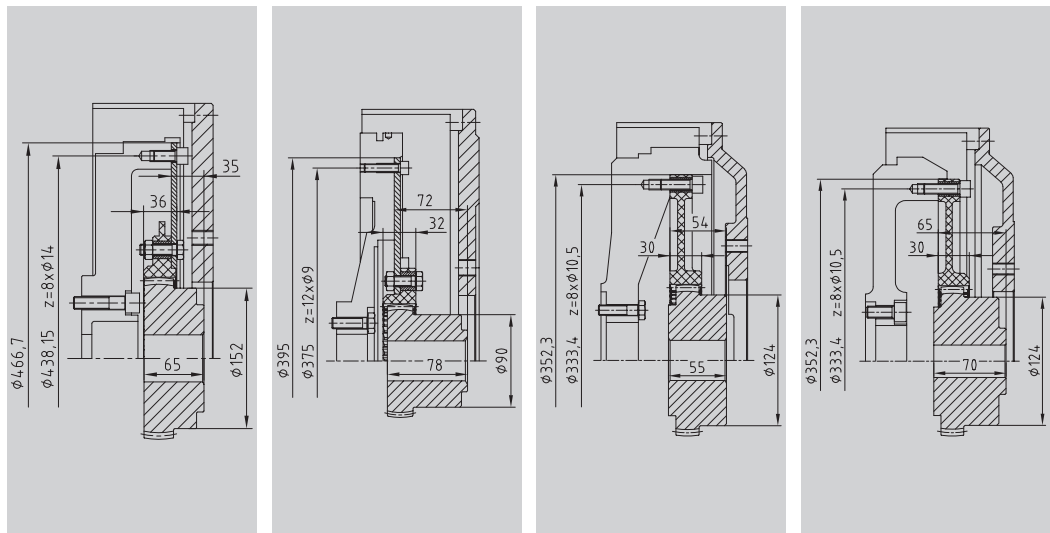

Coupling size
Engine type

BoWex® T100 FLE-PA, 14"
Caterpillar
C 10 / C 12

BoWex® T65 FLE-PA, Ø395
Daimler
OM904

BoWex® 80 FLE-PA, 11 1/2"
Cummins
QSX/QSB

BoWex® 80 FLE-PA 11 1/2"
John Deere

Fitting to shaft motors:
Hatz
Honda
Briggs-Stratton
Yanmar
Kohler
Robin

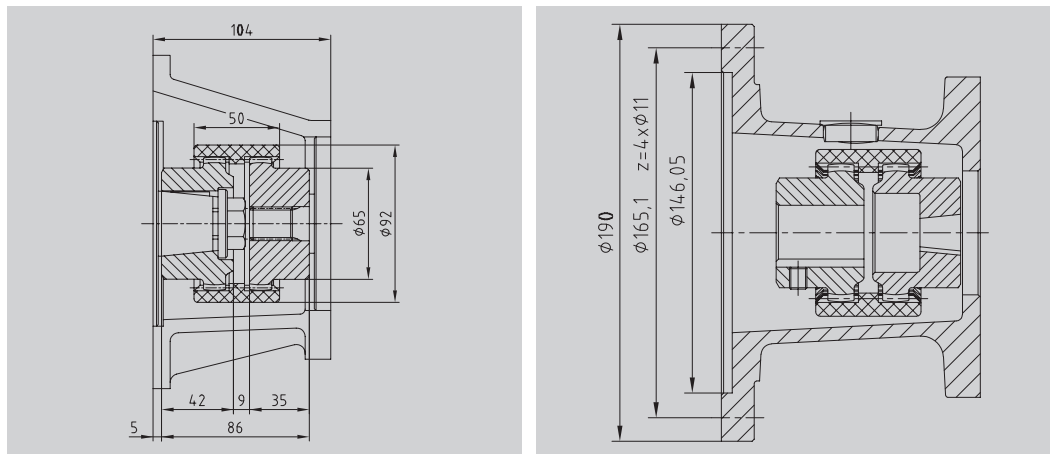

Coupling size
Engine type

BoWex® M42
Hatz 2G30

BoWex® shaft coupling type M28 and M32
Housing connection according to SAE J609A

BoWex® FLE-PA/-PAC

MONOLASTIC®

Flange couplings

BoWex-ELASTIC®

BoWex® FLE-PA

Torsionally rigid flange couplings

Flange couplings and pump connection housings for KUBOTA engines

KUBOTA
Super MINI series

- Z-400
- Z-442-B
- Z-482-B
- D-600
- D-662-B
- D-902-B
- V-800

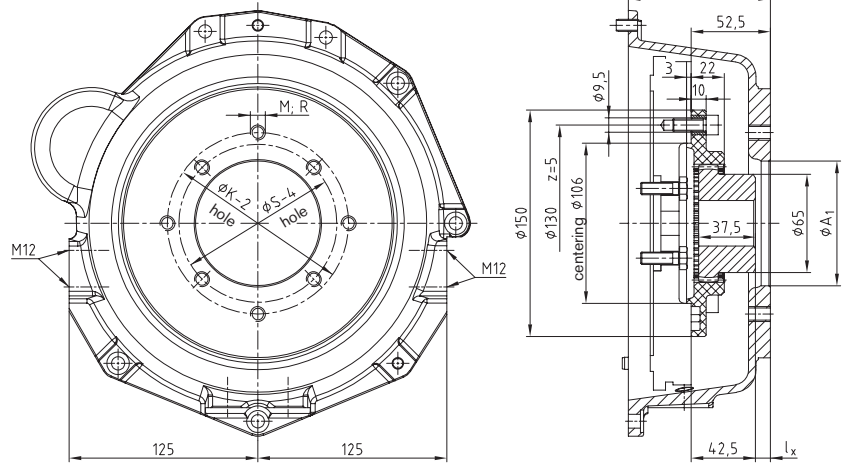

BoWex® 48 FLE-PA Ø 150 / pump connection housings

KUBOTA
Super 3 series

- D 1403/1703
- Flywheel
- No. 190027991
- V 1903/2203
- Flywheel
- No. 190002369
- V 2003-T

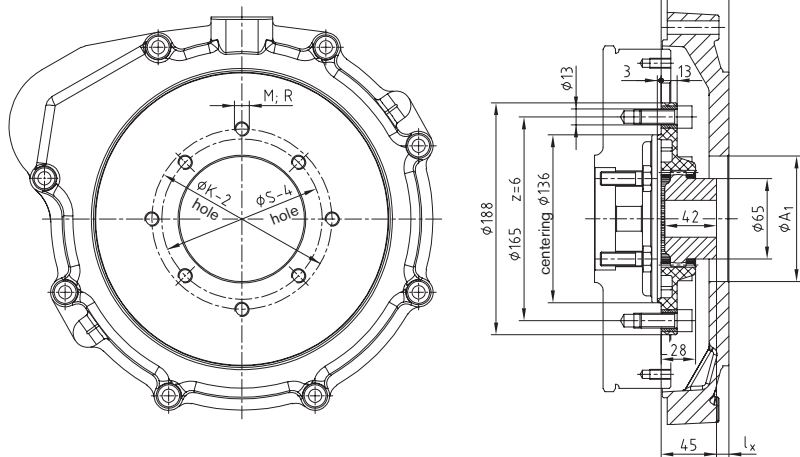

BoWex® 48 FLE-PA Ø 188 / pump connection housings

KUBOTA
Super 5 series

- D 905
- D 1005
- D 1105
- D 1105-T
- V 1205
- V 1305
- V 1505

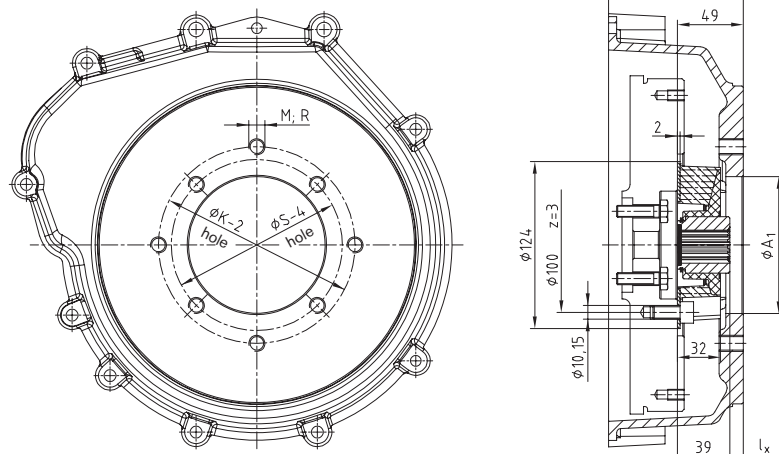

MONOLASTIC® 28 Ø 124 / pump connection housings

BoWex® FLE-PA Torsionally rigid flange couplings

Flange couplings and pump connection housings for Perkins engines

BoWex® FLE-PA/-PAC

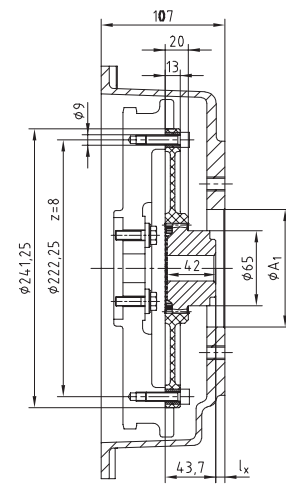
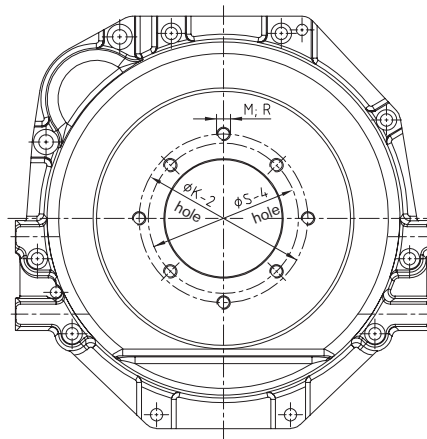
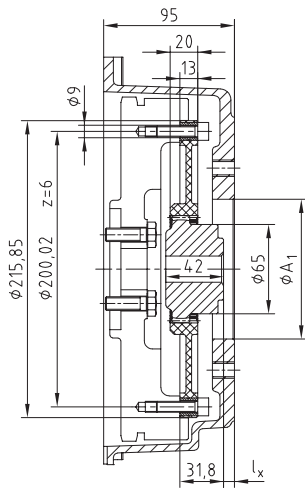

Perkins 403D - 10/11

Perkins 403D - 13/15

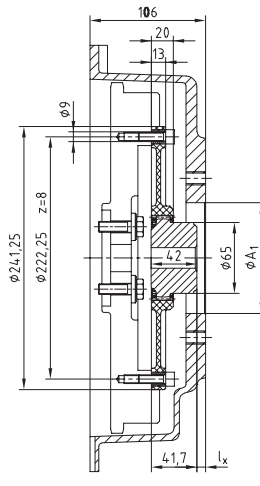
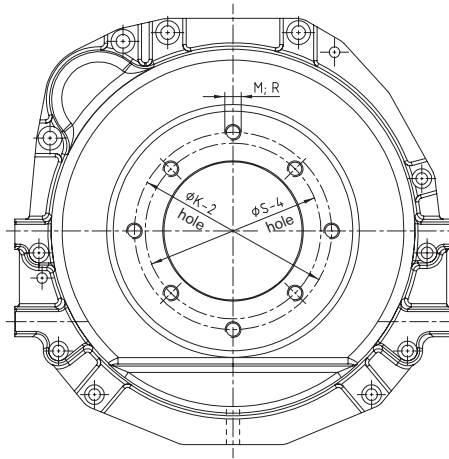
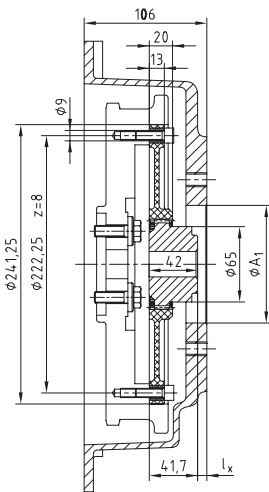

Perkins 404D - 20

Perkins 404D - 22

Other selections on request for Yanmar Mitsubishi etc.

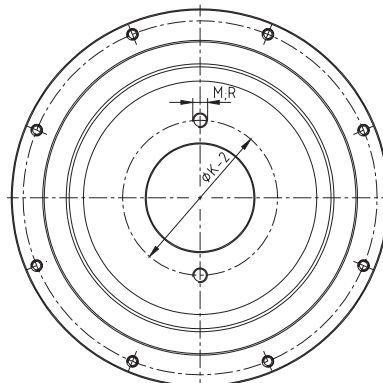

Mitsubishi SL series

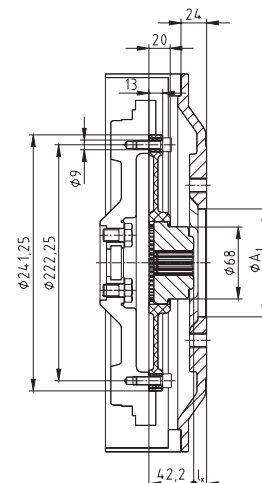

Yanmar TNV series

MONOLASTIC®

Flange couplings

BoWex-ELASTIC®

BoWex® FLE-PA Torsionally rigid flange couplings

Selection of DEUTZ engines FL/M 1011 and FL/M 2011, TCD/TD/D 2.9 L4, TDC/T 3.6 L

Anbaukombination A

Antrieb: Hydraulikpumpen
BoWex® 48 FLE-PA 6 1/2"
SAE-4.0/33 Pumpenanbauflansch

Bezugsfläche
80 33
5,2 11
3 SAE 4
2 Sechskantschraube M8 - DIN ISO 4017
Anziehdrehmoment $T_A=25\text{Nm}$
Festigkeitsklasse > 8.8
Klebesicherung im Gewinde
 $\phi 215,9$
 $\phi 200,02$ z=6x $\phi 9$
13
36 max. $\phi 4,8$ $\phi 68$ SAE A, B, C $\phi 164$
2 Zylinderschraube M8 - DIN 912
Anziehdrehmoment $T_A=25\text{Nm}$
Festigkeitsklasse > 8.8
Klebesicherung im Gewinde
50
3

Antrieb: Kompressoren,
Wasserpumpen usw.
BoWex-Elastic® HE 6 1/2"

Anbaukombination B

Anbaukombination C

Antrieb: Hydraulikpumpen
BoWex® 48 FLE-PA 8"
SAE-4.3/24 Pumpenanbauflansch

Bezugsfläche
80 24
8,9 10
3 SAE 4
1 Sechskantschraube
M10 - DIN ISO 4017
Anziehdrehmoment $T_A=49\text{Nm}$
Festigkeitsklasse > 8.8
Klebesicherung im Gewinde
 $\phi 263,45$
 $\phi 244,47$ z=6x $\phi 10,5$
13 max. $\phi 4,2$ SAE A, B, C
42

Anbaukombination D

Antrieb: Hydraulikpumpen
BoWex® T55 FLE-PA 8"
SAE-4.0/38 Pumpenanbauflansch

Bezugsfläche
80 38
8,9 11
3 SAE 4
1 Zylinderschraube M8 - DIN 912
Anziehdrehmoment $T_A=49\text{Nm}$
Festigkeitsklasse > 8.8
Klebesicherung im Gewinde
 $\phi 263,45$
 $\phi 244,47$ z=6x $\phi 10,5$
13 max. $\phi 1,4$ $\phi 85$ SAE A, B, C
50

ACHTUNG: Entsprechend der Motorleistung ist die Kupplungsanordnung durch den Anwender zu prüfen. Nach erfolgtem Kupplungsanbau Kurbelwellenlangspiel prüfen. Sollmaß für Lagerluft $\phi,1 \dots 0,3\text{mm}$. DEUTZ übernimmt keine Haftung für außerhalb des DEUTZ Lieferumfanges liegende Maßgaben und/oder Teile.

1	1	1	3	Zwischengehäuse (SAE-4)	0427 0980 KZ 0138-52 0417 1040 UA 0138-52	15	0553	
-	-	1	2	Schwungrad (SAE 6 1/2") J= 0,499 kgm'	0428 0586 KZ 0138-05 0417 1301 UA 0138-05	30,3	3174	
1	1	-	1	Schwungrad (SAE 8 u 10") J= 0,485 kgm'	0427 2426 KZ 0138-05 0417 1301 UA 0138-05	25,3	2461	
D	C	B	A	Pos.	Benennung	Nummer	G ^(kg)	Baus.-Nr.

DIMENSIONS ARE IN MILLIMETERS		UNLESS OTHERWISE SPECIFIED		GEOMETRIC TOLERANCES PER ISO 1101	SURFACE TEXTURE PER ISO 1312	MATERIAL	PROJECTION METHOD
CORNERS PER DIN 6764		GENERAL TOLERANCES		IN MICROMETERS	IN MICROMETERS		ISO 121
Bauart	FL/M1011 FL/M2011	Werkstoffangaben nach DIN 6716	Form- und Lagermaßangaben nach DIN 7161	Form- und Lagermaßangaben nach DIN 7161	0,2	Stahl 11	1
Skala	1:1	Äußere Maßangaben nach DIN 401	Äußere Maßangaben nach DIN 401	Äußere Maßangaben nach DIN 401	0,2		
Skizze							
Blatt	1	Datum	17.12.83	Sh			
Gez.		Gez.	12.02.83	Sh			
Norm		Norm					
Kupplungsanbau BoWex® FLE-PA / ELASTIC HE							
DEUTZ AG							
0428 0967 UB 0138-97							

BoWex® FLE-PA Torsionally rigid flange couplings

Selection of DEUTZ engines BFM 1012/1013/2012/2013/1015

Anbaukombination A

Deutz-Motor
BF4/6M 1012/2012, BF4/6 1013/2013,
TCD/TD 2012 L04/06 2V/4V, TCD/TD 2013 L04 2V, TCD 4.1 L4

BoWex® 65 FLE-PA 10"
SAE-4/9 Pumpenanbauflansch

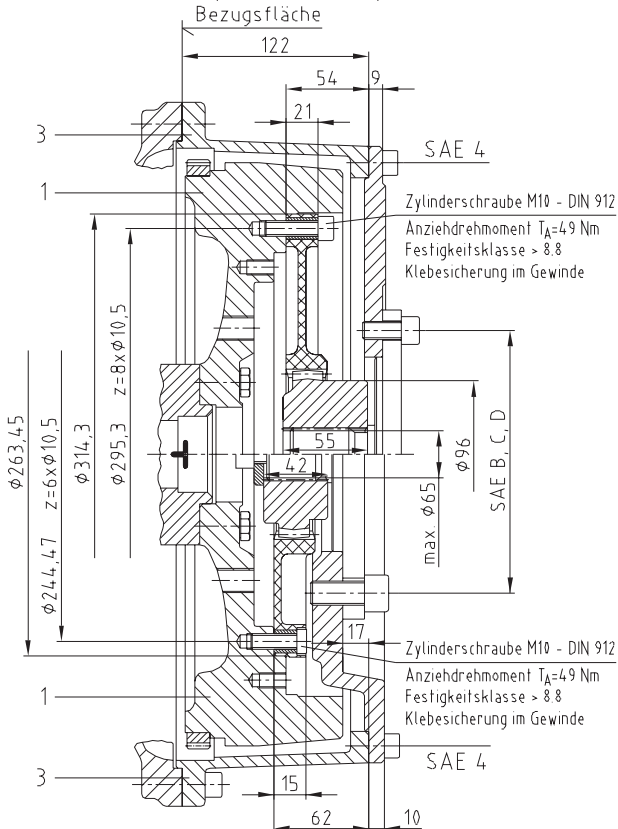

Anbaukombination B

Deutz-Motor
BF4/6M 1012/2012, BF4/6 1013/2013,
TCD/TD 2012 L04/06 2V/4V, TCD/TD 2013 L04 2V, TCD 4.1 L4

BoWex® 65 FLE-PA 8"
SAE-4.2/-17 Pumpenanbauflansch

Anbaukombination C

Deutz-Motor
BF4/6M 1012/2012, BF4/6 1013/2013,
TCD/TD 2012 L04/06 2V/4V, TCD/TD 2013 L04/06 2V, TCD 4.1 L4, TCD 6.1 L6

BoWex® 80 FLE-PA 11 1/2"
SAE-3/9 Pumpenanbauflansch

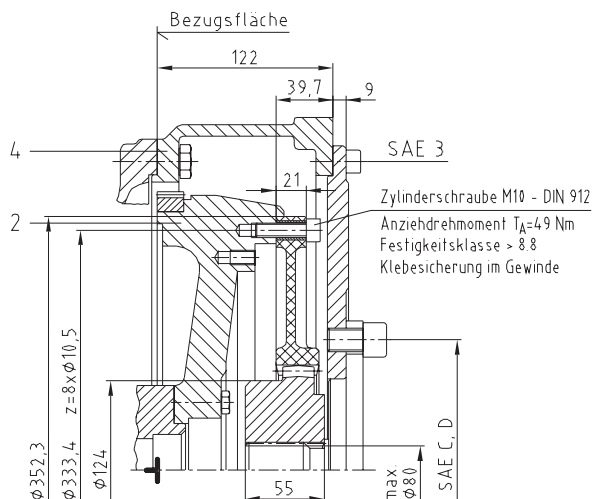

Anbaukombination D

Deutz-Motor
BF6/8M 1015/2015,
TCD 2015 V06, TCD 12 0 V6

BoWex® 100 FLE-PA 14"
SAE-1/20 Pumpenanbauflansch

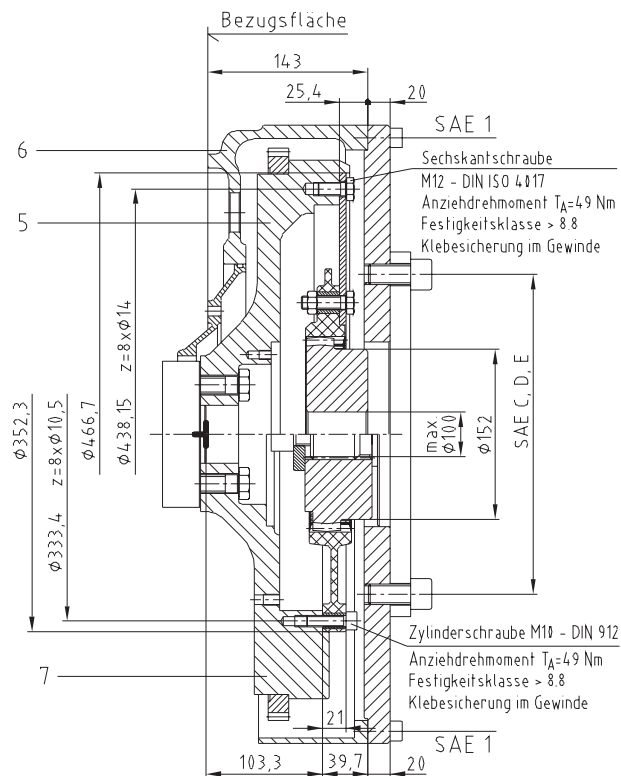

Anbaukombination E

Deutz-Motor
BF6/8M 1015/2015,
TCD 2015 V06, TCD 12 0 V6

BoWex® 100 FLE-PA 11 1/2"
SAE-1/20 Pumpenanbauflansch

ACHTUNG: Entsprechend der Motorleistung ist die Kupplungsanordnung durch den Anwender zu prüfen. Nach erfolgtem Kupplungsanbau Kurbelwellenlängsspiel prüfen. Sollmaß für Lagerluft: Motor 1012/1013/2012/2013 = 0,1 - 0,28 mm; Motor 1015 = 0,2 - 0,4 mm
DEUTZ übernimmt keine Haftung für außerhalb des DEUTZ Lieferumfanges liegende Maßgaben und/oder Teile.

Bei techn. Rückfragen hinsichtlich der Kupplungsausführung wenden Sie sich bitte an KTR-Kupplungstechnik GmbH; Postfach 1763; D-48407 Rheine; Tel.: 05971/798-0

1	-	-	-	7	Schwungrad (SAE-11 1/2") J= 2,255 kgm ²	66,7		
1	1	-	-	6	Anschlußgehäuse (SAE-11)	45,6		
-	1	-	-	5	Schwungrad (SAE-14") J= 2,264 kgm ²	61,6		
-	-	1	-	4	Anschlußgehäuse (SAE-3)			
-	-	-	1	3	Anschlußgehäuse (SAE-4)			
-	-	1	-	2	Schwungrad (SAE-10 u. 11 1/2") J= 0,872 kgm ²			
-	-	-	1	1	Schwungrad (SAE-8 u. 10") J= 1,03 kgm ²			
E	D	C	B	A	Pos.	Benennung	Nummer	G ^{kg} Baus.-Nr.
Anbaukombination								

DEUTZ 1012 / 1013
siehe 0420 8900 UB 0130-97

MONOLASTIC®

One-piece, flexible flange couplings

Type with 3 holes (EP 0853203/U.S. Patent 6,117,017)

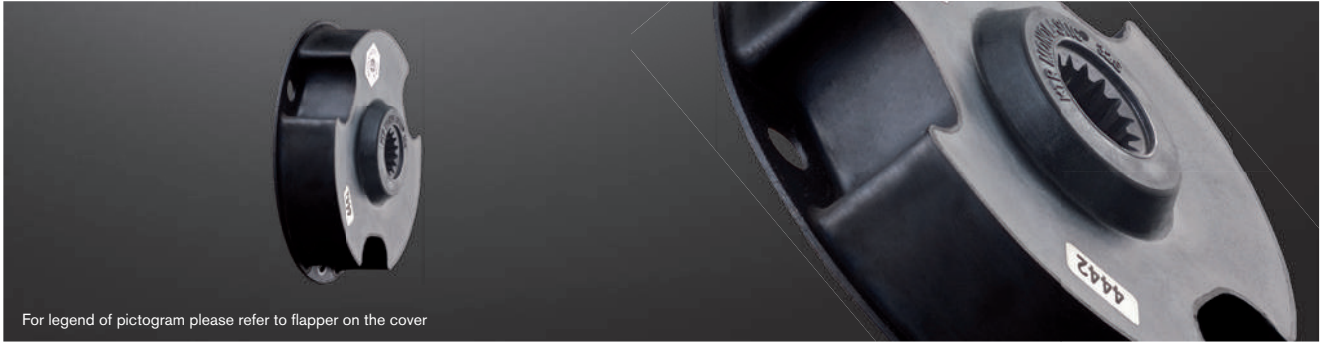

For legend of pictogram please refer to flapper on the cover

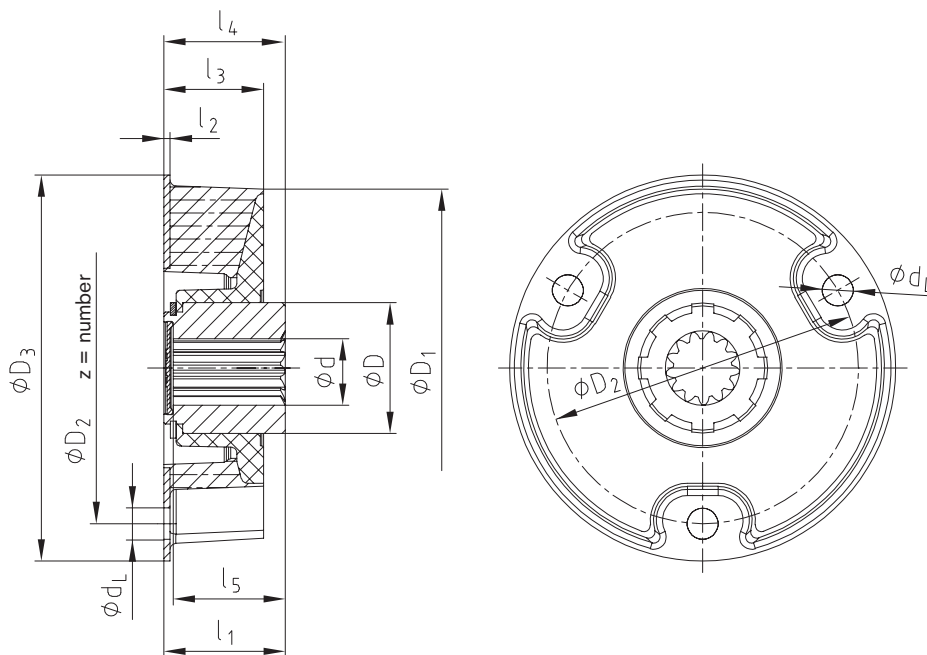
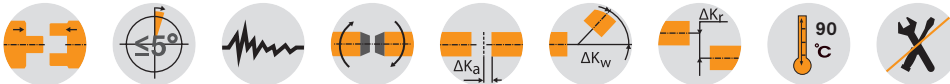

MONOLASTIC®																
Size	Elastomer hardness [Shore A]	Torque [Nm]			Dimensions [mm]											
		T _{KN}	T _{K max}	T _{KW}	d	D	D ₁	D ₂	z	d _L	D ₃	l ₁	l ₂	l ₃	l ₄	l ₅
22	65	40	100	20	20	34	93	80	3	8.10	100	33	1.5	32	34	30
	70	70	175	35	25	42	115	100	3	10.10	124	40	2	32	40	38
28	65	160	400	80	32	50	140	125	3	12.10	150	42	2	42	43	38
	70	225	562	112	32	50	175	165	3	16.15	200	46	3	35	46	43
32	65	260	650	130	32	50	167	140	3	14.10	175	46	3	35	46	43
50-140	70	300	750	150	32	50	175	165	3	16.15	200	46	3	35	46	43
50-165	70	300	750	150	32	50	175	170	3	16.15	200	46	3	35	46	43
50-170	70	400	1000	200	48	68	191	165	3	16.15	205	50	3	40	55	46

Technical data										
Size	Elastomer hardness [Shore A]	C _{dyn.} with 60 °C [Nm/rad]	Perm. damping power with 60 °C P _{KW} [W]	Max. displacement with 2200 rpm ΔK _r [mm]	Perm. angular displacement with 2200 rpm ΔK _w [°]	Radial spring stiffness C _r [N/mm]	Mass moment of inertia [kgm ²]		Max. perm. operating speed n _{max.} [rpm]	
							J _A	J _L		
22	65	600	10	0.6		200	0.00017	0.00010	6000	
28	65	900	15	0.6		300	0.00054	0.00033	6000	
	70	1300	25	0.5		400	0.00120	0.00081	6000	
32	65	1800	25	0.6		400	0.00120	0.00081	6000	
	70	2400	35	0.5	1	500	0.00210	0.00130	6000	
50-140	70	4200	35	0.5		1365	0.00210	0.00130	6000	
50-165	70	5600	40	0.5		1550	0.00250	0.00130	6000	
50-170	70	5600	40	0.5		1550	0.00250	0.00130	6000	
60-165	70	7800	40	0.5		1500	0.00599	0.00358	6000	

MONOLASTIC®

One-piece, flexible flange couplings

Type SAE (EP 0853203/U.S. Patent 6,117,017)

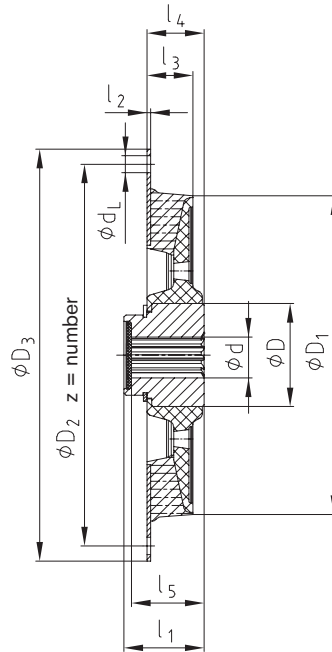
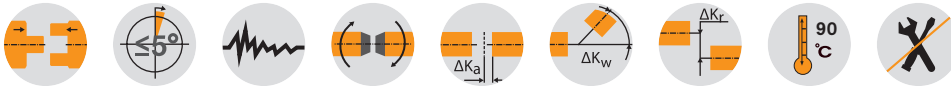
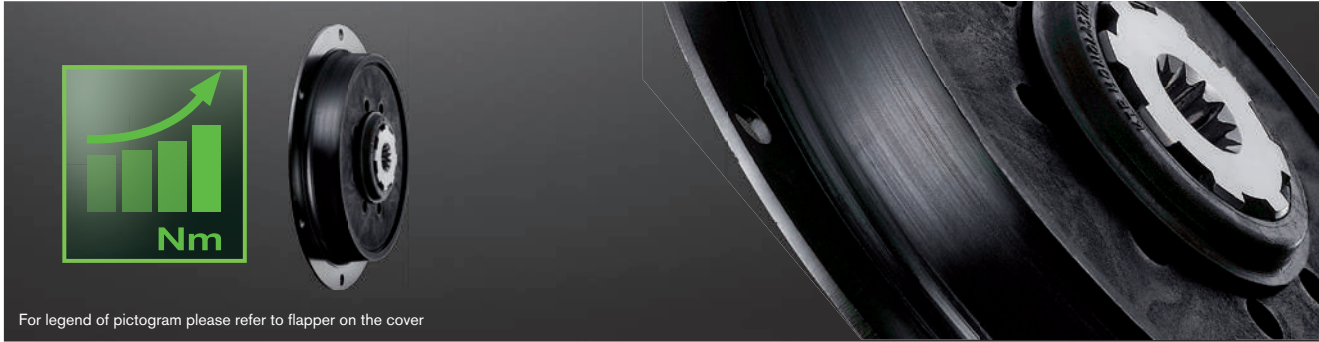

Flange dimensions according to SAE J620 [mm]				
Size	D ₃	D ₂	z	d _L
6 1/2"	215.9	200.02	6	9
7 1/2"	241.3	222.25	8	9
8"	263.52	244.47	6	11
10"	314.32	295.27	8	11
11 1/2"	352.42	333.37	8	11

MONOLASTIC®																	
Size	Elastomer hardness [Shore A]	Torque [Nm]			Dimensions [mm]								MONOLASTIC® flanges according to SAE				
		T _{KN}	T _{K max}	T _{KW}	d	D	D ₁	l ₁	l ₂	l ₃	l ₄	l ₅	6 1/2"	7 1/2"	8"	10"	11 1/2"
30	65	200	400	100	25	42	120	39	2	21	30	36	X	X			
	70	250	500	125													
50	65	350	700	175	32	50	167	42	2	24	30	38	X	X	X	X	
	70	450	900	225													
G50	70	600	1200	300	32	50	178	42	2	24	36	38		X	X	X	
65	65	750	1500	375	48	68	200	45	3	32	45	42				X	X
	70	1000	2000	500													
75	65	1500	3000	750	60	90	265	58	3	35	50	54				X	X
	70	1850	3700	925													

■ = Years of experience with applications at customer sites and additional test series in the KTR test field in Rheine enabled us to determine potentials allowing for an increase of the rated torques with some sizes of this series.

Technical data										
Size	Elastomer hardness [Shore A]	C _{dyn.} with 60 °C [Nm/rad]	Perm. damping power with 60 °C P _{KW} [W]	Max. displacement with 2200 rpm ΔK _r [mm]	Perm. angular displacement with 2200 rpm ΔK _w [°]	Radial spring stiffness C _r [N/mm]	Mass moment of inertia [kgm ²]		Max. perm. operating speed n _{max.} [rpm]	
							J _A	J _L		
30	65	3750	25	0.5	1	1150	6 1/2"	0.0038	0.00030	6000
	70	4875				1500	7 1/2"	0.0057		
50	65	9000	35	0.5	1	1300	8"	0.0078	0.00120	6000
	70	12000				1700	10"	0.0153		
G50	70	17500	40	0.5	1	1910	7 1/2"	0.0060	0.00120	6000
							8"	0.0080		
							10"	0.0162		
65	65	14000	45	0.5	1	1900	10"	0.0238	0.00380	6000
	70	18000				2450	11 1/2"	0.0368		
75	65	34000	80	0.5	1	1850	10"	0.0272	0.01450	6000
	70	42000				2400	11 1/2"	0.0402		

MONOLASTIC®

One-piece, flexible flange couplings

Examples of installation for type with 3 holes (EP 0853203/U.S. Patent 6,117,017)

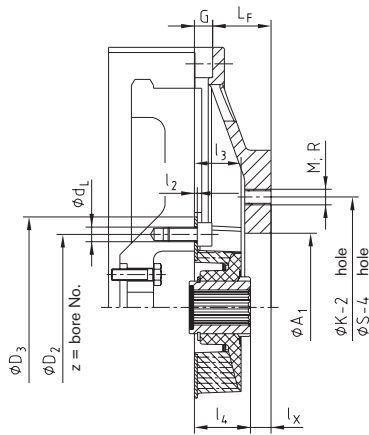

MONOLASTIC® 28
with spline shaft

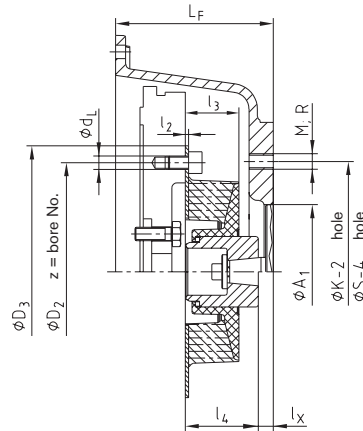

MONOLASTIC® 28
with taper shaft

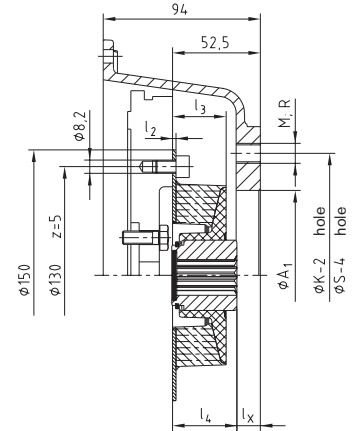

MONOLASTIC® 28
KUBOTA - Mini

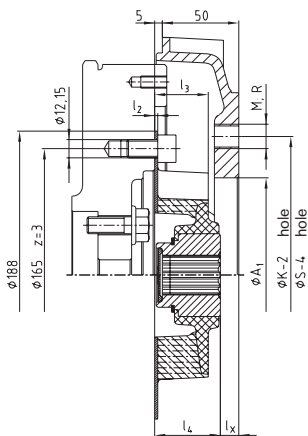

MONOLASTIC® 32 - 188
KUBOTA Super Three Series

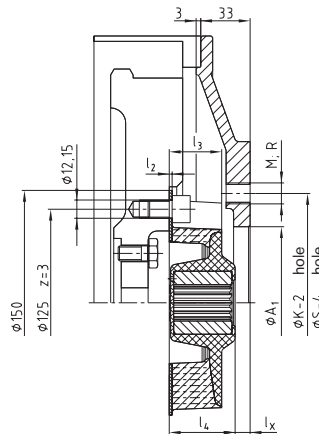

MONOLASTIC® 32 S

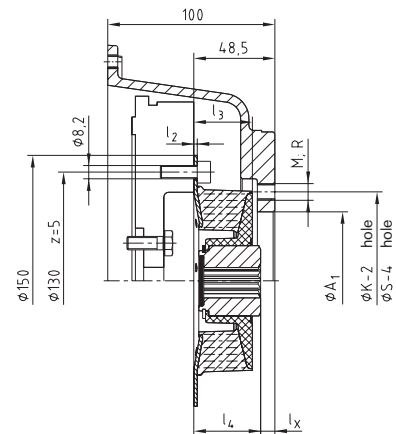

MONOLASTIC® 28
KUBOTA Super Mini

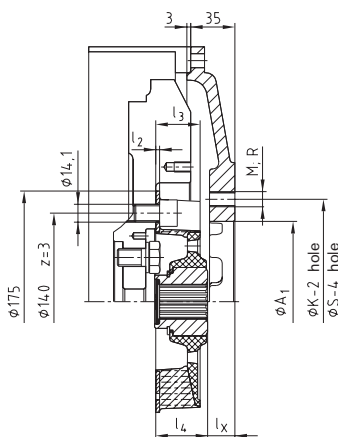

MONOLASTIC® 50 - 140

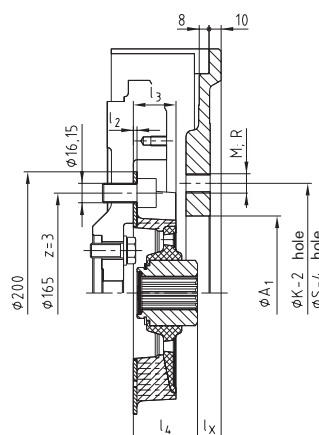

MONOLASTIC® 50 - 165

MONOLASTIC®

One-piece, flexible flange couplings

Examples of installation for SAE type (EP 0853203/U.S. Patent 6,117,017)

BoWex® FLE-PA/-PAC

MONOLASTIC®

Flange couplings

BoWex-ELASTIC®

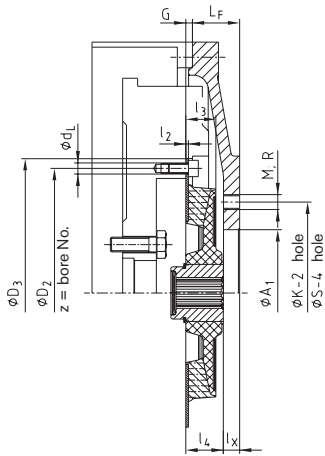

MONOLASTIC® 30
with spline shaft

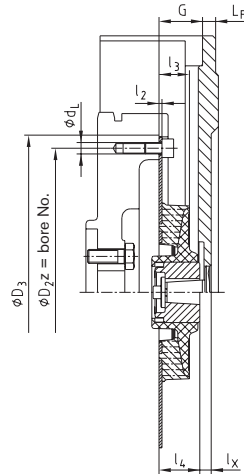

MONOLASTIC® 30
with taper shaft

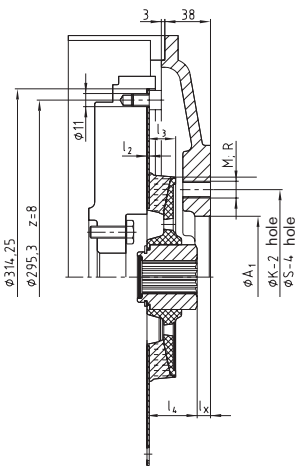

MONOLASTIC® 50 - 10"

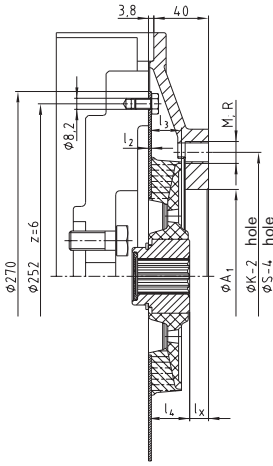

MONOLASTIC® 50 - 270
KUBOTA engine
D1803, V2403, V2403T

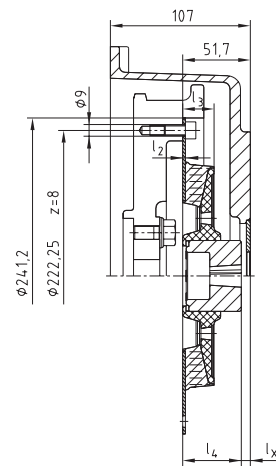

MONOLASTIC® 50
Perkins engine
403-13/403-15

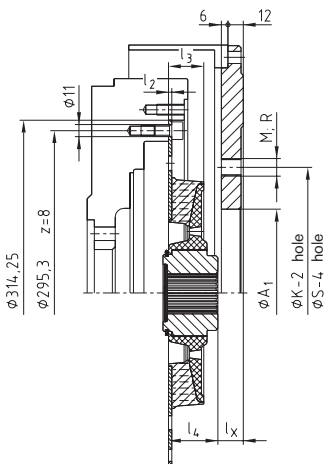

MONOLASTIC® 65 - 10"

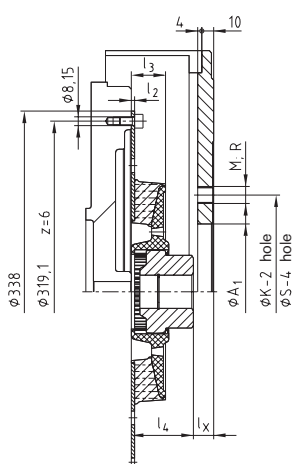

MONOLASTIC® 65 / T48

BoWex-ELASTIC® HE1 - HE4

Highly flexible flange couplings

Axial plug-in, available in different kinds of hardness



For legend of pictogram please refer to flapper on the cover

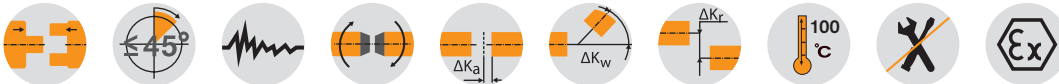

BoWex-ELASTIC® Type HE1 - HE4

Size	Bore d [mm]		Flange connection acc. to SAE - J620														Dimensions [mm]				Type HE1 / HE2			Type HE3 / HE4	
	Pilot bored	Max.	6 1/2"	7 1/2"	8"	10"	11 1/2"	14"	l3 HE1/HE2	l3 HE3/HE4	D5	l2	D4	D	l1	LHE1	LHE2	LHE3	LHE4	Weight with max. bore [kg]	Mass moment of inertia with max. bore [kgm²]		Weight with max. bore [kg]	Mass moment of inertia with max. bore [kgm²]	
																					JA	JL		JA	JL
42 HE	-	42	●	●	●				4	2	180	33	145	65	42	70	50	55	40	1.8	0.0074	0.0016	1.8	0.0071	0.0021
																					2.8	0.0172	0.0016	-	-
48 HE	-	48	●	●	●				4	2	198	37	163	68	50	78	50	68	42	2.3	0.0119	0.0021	1.9	0.0070	0.0022
																					2.6	0.0170	0.0021	2.1	0.0103
65 HE	21	65				●			5	-	244	55	205	96	55	85	62	-	-	4.9	0.0342	0.0021	2.5	0.0201	0.0022
																					5.7	0.0647	0.0069	-	-
G 65 HE						●			-	3	-	45	205	96	55	-	-	73	50	-	-	-	4.1	0.0281	0.0075
																					-	-	-	4.6	0.0423
GG 65 HE						●			-	3	-	48	220	96	55	-	-	73	50	-	-	-	3.8	0.0163	0.0093
																					-	-	-	4.4	0.0294
80 HE	31	90				●			-	4	316	56	265	124	90	126	74	112	60	8.1	0.0239	0.0307	9.1	0.0414	0.0305
										6	-	-	-	-	-	-	132	80	-	-	10.2	0.0765	0.0307	-	-
G 80 HE	31	90				●			-	4	356	66	300	124	90	136	80	122	70	9.7	0.0426	0.0471	11.1	0.0713	0.0472
										6	-	-	-	-	-	-	142	84	-	-	14.7	0.2851	0.0471	-	-
GG 80 HE						●			-	4	-	71	302	124	90	-	-	130	80	-	-	-	4.4	0.0294	0.0093
																					-	-	-	11.9	0.0768
100 HE	38	100				●			-	4	-	80	350	152	110	142	90	150	82	-	-	-	18.3	0.2028	0.1104

Other flange connections on request

Technical data

Size	Shore	Torque [Nm]			Perm. damping power PKW [W]			Perm. operating speed n _{max} [rpm]	Dynamic torsion spring stiffness C _{dyn} [Nm/rad]	Relative damping ψ	Resonance factor VR ≈ π / ψ	Radial spring stiffness Cr [N/mm]
		TKN	TK max	with 10 Hz TKW	60 °C	80 °C	90 °C					
42 HE	T40 Sh	130	390	39	26	13	6.5	6200	550	0.6	10.5	142
	T50 Sh	150	450	45					850	0.8	7.9	219
	T65 Sh	180	540	54					2700	1.2	5.2	697
48 HE	T40 Sh	200	600	60	36	18	9	5600	850	0.6	10.5	176
	T50 Sh	230	690	69					1300	0.8	7.9	269
	T65 Sh	280	840	84					3500	1.2	5.2	724
65 HE	T40 Sh	350	1050	105	60	30	15	4500	1600	0.6	10.5	209
	T50 Sh	400	1200	120					2200	0.8	7.9	288
	T65 Sh	500	1500	150					6000	1.2	5.2	784
G 65 HE	T40 Sh	430	1290	129	68	34	17	4300	2350	0.6	10.5	259
	T50 Sh	500	1500	150					3000	0.8	7.9	346
	T65 Sh	620	1860	186					8500	1.2	5.2	975
GG 65 HE	T40 Sh	600	1800	180	76	38	19	4000	3650	0.6	10.5	240
	T50 Sh	700	2100	210					4800	0.8	7.9	324
	T65 Sh	850	2550	255					13500	1.2	5.2	911
80 HE	T40 Sh	750	2250	225	120	60	30	3600	4500	0.6	10.5	351
	T50 Sh	950	2850	285					6500	0.8	7.9	507
	T65 Sh	1200	3600	360					18000	1.2	5.2	1404
G 80 HE	T40 Sh	1250	3750	375	180	90	45	3000	7500	0.6	10.5	476
	T50 Sh	1600	4800	480					12000	0.8	7.9	762
	T65 Sh	2000	6000	600					32000	1.2	5.2	2031
GG 80 HE	T40 Sh	1550	4650	465	196	98	49	3000	9200	0.6	10.5	395
	T50 Sh	2000	6000	600					14200	0.8	7.9	635
	T65 Sh	2500	7500	750					39600	1.2	5.2	1650
100 HE	T40 Sh	2000	6000	600	212	106	53	2700	12000	0.6	10.5	366
	T50 Sh	2500	7500	750					19000	0.8	7.9	570
	T65 Sh	3200	9600	960					48000	1.2	5.2	1200

T = Temperature-stable rubber compound. The technical data specified apply for an ambient temperature of T = 60 °C.

* Expiring as a standard

Ordering example:	BoWex-ELASTIC® 42	HE1	40	8	70	U
	Coupling size	Type	Elastomer hardness	Flange Ø DA according to SAE or special	Mounting length LHE	Unbored or with finish bore

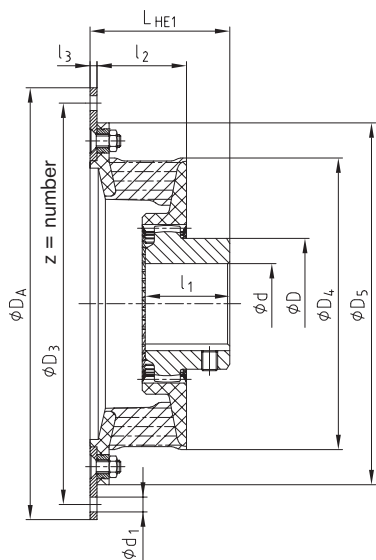

Type HE1

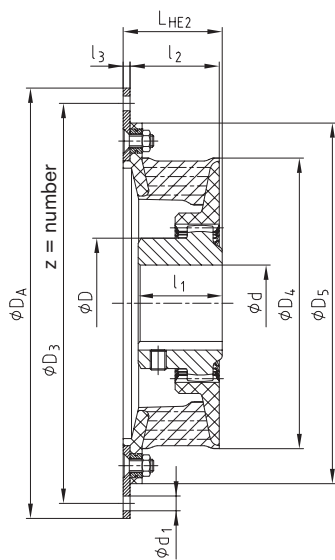

Type HE2

Flange dimensions according to SAE J620 [mm]				
Nominal size	DA	D3	z	d1
6 1/2"	215.90	200.02	6	9
7 1/2"	241.30	222.25	8	9
8"	263.52	244.47	6	11
10"	314.32	295.27	8	11
11 1/2"	352.42	333.37	8	11
14"	466.72	438.15	8	13

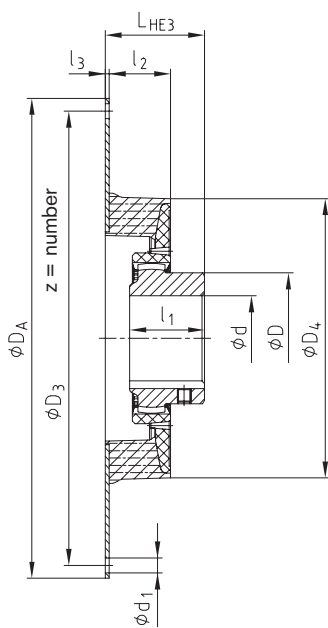

Type HE3

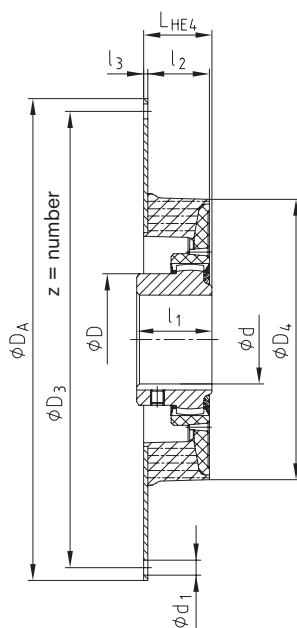

Type HE4

Displacements																
Size	42 HE			48 HE			65 HE G65 HE GG65 HE			80 HE G80 HE GG80 HE			100 HE			
	T40 Sh	T50 Sh	T65 Sh	T40 Sh	T50 Sh	T65 Sh	T40 Sh	T50 Sh	T65 Sh	T40 Sh	T50 Sh	T65 Sh	T40 Sh	T50 Sh	T65 Sh	
Elastomer hardness [Shore A]																
Perm. radial displacement ΔKr [mm]	n=1500 rpm	1.1	1.0	0.5	1.2	1.1	0.5	1.6	1.5	0.7	1.8	1.7	0.8	2.2	2.0	1.0
	max. 1)	3.6	3.3	1.5	3.8	3.5	1.7	5.1	4.7	2.2	5.7	5.3	2.4	6.5	6.0	3.0
Perm. angular displacement ΔKw [°]	n=1500 rpm	1.0	0.75	0.5	1.0	0.75	0.5	1.0	0.75	0.5	1.0	0.75	0.5	1.0	0.75	0.5
	n=3000 rpm	0.5	0.4	0.25	0.5	0.4	0.25	0.5	0.4	0.25	0.5	0.4	0.25	0.5	0.4	0.25
Perm. angular displacement ΔKw [mm]	max. 1)	1.5			1.5			1.5			1.5			1.5		
Perm. axial displacement ΔKa [mm]	± 2			± 2			± 2			± 2			± 3			

1) For short-term start-up operation

Mounting procedure, screw type with property class, tightening torques as per KTR assembly instructions (see www.ktr.com).

BoWex-ELASTIC® HE3 / HE4 / HE-D

Highly flexible flange couplings

Axial plug-in, available in different kinds of hardness

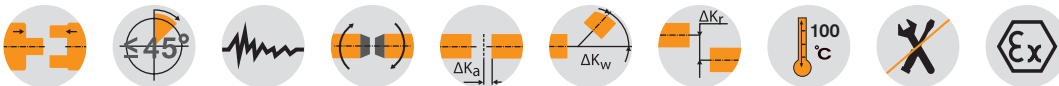

BoWex-ELASTIC® Type HE3, HE4 and HE-D

Size	Bore d [mm]		Flange connection acc. to SAE - J620						Dimensions [mm]						Weight with max. bore [kg]	Mass moment of inertia with max. bore [kgm²]			
	Pilot bored	Max.	14"	16"	18"	21"	24"	Ø800	Ø885	l ₃	l ₂	D ₄	D	l ₁		LHE3	LHE4	J _A	J _L
125 HE	45	125	•							6	92	416	192	140	186	103	33.1	0.3142	0.2750
G125 HE	45	125		•						6	89	440	192	140	179	91	34.8	0.4231	0.2750
150 HE	44	160			•					6	140	470	225	150	205	160	36.6	0.4634	0.3264
150 HE-D	44	160			•					-	286	470	225	275	291	-	39.5	0.6812	0.3264
G150 HE	44	160			•	•				6	140	504	225	150	205	160	46.8	0.7277	0.5414
G150 HE-D	44	160			•	•				-	286	504	225	275	291	-	51.5	1.2120	0.5414
200 HE	46	180				•	•			6	149	568	250	175	240	160	113	3.0045	1.0738
200 HE-D	46	180				•	•			-	325	568	250	298	310	-	155	6.4399	1.0738
G200 HE	46	180				•	•			6	149	600	250	175	240	160	51.9	0.8164	0.6500
G200 HE-D	46	180				•	•			-	325	600	250	298	310	-	56.6	1.3007	0.6500
240 HE	80	240					•	•		8	172	772	326	200	270	205	123	3.1820	1.291
275 HE	80	275						•	•	10	185	810	372	240	312	215	165	6.6173	1.291

Technical data

Size	Shore	Torque [Nm]				Perm. damping power PKW [W]			Perm. operating speed n _{max.} [rpm]	Dynamic torsion spring stiffness C _{dyn.} [Nm/rad] 60 °C	Relative damping ψ	Resonance factor V _R ≈ 2 • π / ψ	Radial spring stiffness C _r [N/mm]
		T _{KN} [Nm]	T _K max 10,000 LW [Nm]	T _K max 50,000 LW [Nm]	T _{KW} [Nm]	60 °C	80 °C	90 °C					
125 HE	T50 Sh	4300	12900	6450	1075	221	133	88	2300	30000	0.8	7.9	617
	T70 Sh	7500	22500	11250	1875								
G125 HE	T50 Sh	6100	18300	9150	1525	240	144	96	2250	51000	0.8	7.9	560
	T70 Sh	9750	29250	14625	2438								
150 HE	T50 Sh	8000	24000	12000	2000	262	157	105	2200	67500	0.8	7.9	714
	T70 Sh	14000	42000	21000	3500								
150 HE-D	T50 Sh	16000	48000	24000	4000	524	314	210	2200	134000	0.8	7.9	1428
	T70 Sh	28000	84000	42000	7000								
G150 HE	T50 Sh	10000	30000	15000	2500	278	167	111	2100	85000	0.8	7.9	1485
	T70 Sh	18000	54000	27000	4500								
G150 HE-D	T50 Sh	20000	60000	30000	5000	556	334	222	2100	170000	0.8	7.9	2970
	T70 Sh	36000	108000	54000	9000								
200 HE	T50 Sh	14500	43500	21750	3625	308	185	123	1900	119000	0.8	7.9	1720
	T70 Sh	25000	75000	37500	6250								
200 HE-D	T50 Sh	29000	87000	43500	7250	616	370	246	1900	238000	0.8	7.9	3440
	T70 Sh	50000	150000	75000	12500								
G200 HE	T50 Sh	17500	52500	26250	4375	324	194	130	1800	139000	0.8	7.9	1952
	T70 Sh	30000	90000	45000	7500								
G200 HE-D	T50 Sh	35000	105000	52500	8750	648	388	260	1800	278000	0.8	7.9	3904
	T70 Sh	60000	180000	90000	15000								
240 HE	T50 Sh	29000	87000	43500	7250	372	223	149	1500	259000	0.8	7.9	2326
	T70 Sh	49000	147000	73500	12250								
275 HE	T50 Sh	42000	126000	63000	10500	410	246	164	1500	375000	0.8	7.9	2950
	T70 Sh	70000	210000	105000	17500								

• = Years of experience with applications at customer sites and additional test series in the KTR test field in Rheine enabled us to determine potentials allowing for an increase of the rated torques with some sizes of this series.

Ordering example:	BoWex-ELASTIC® 80	HE3	40	10	112	U
	Coupling size	Type	Elastomer hardness	Flange Ø D _A according to SAE or special	Mounting length L _{HE}	Unbored or with finish bore

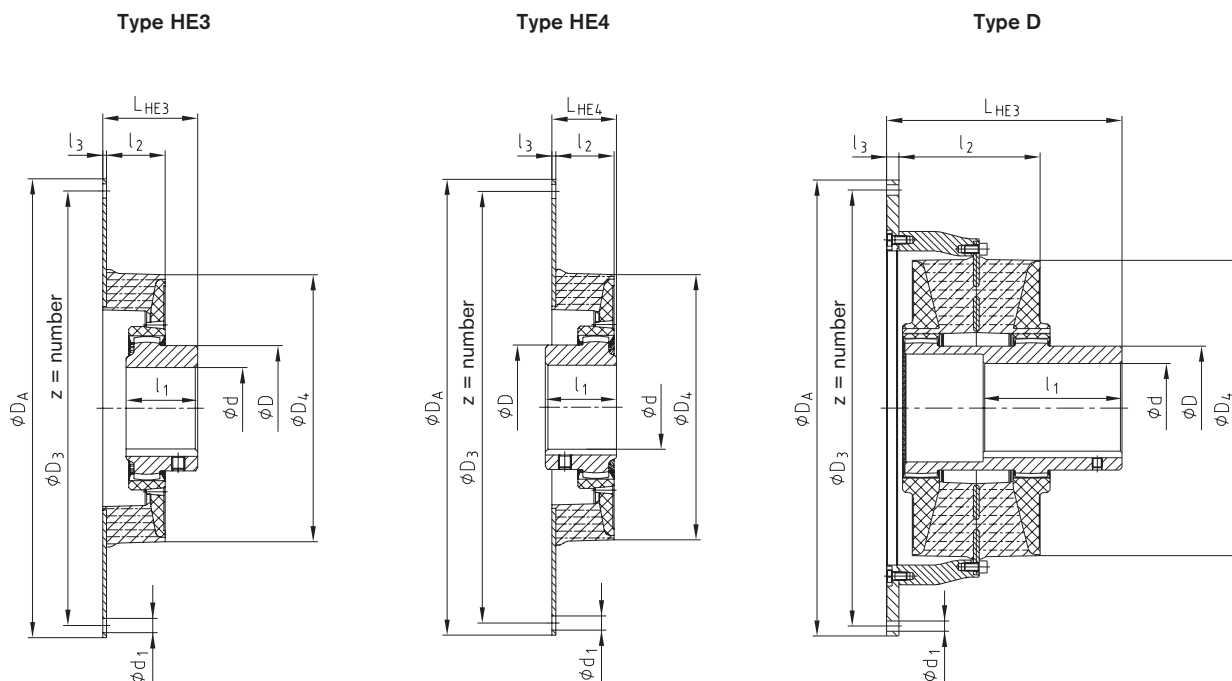

Flange dimensions according to SAE J620 [mm]				
Nominal size	DA	D3	z	d1
14"	466.72	438.15	8	13
16"	517.50	489.00	8	13
18"	571.50	542.90	6	17
21"	673.10	641.35	12	17
24"	733.42	692.15	12	21
Ø800	800	770	32	17
Ø885	885	855	36	17

Displacements

For different operating speeds or higher operating temperatures the permissible radial displacement is calculated as follows:

$$\Delta K_{rperm.} = \Delta Kr \cdot St \cdot \sqrt{1500 / nx}$$

Radial displacement ΔKr Angular displacement

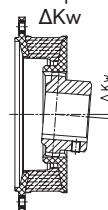
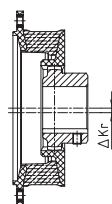

Axial displacement ΔKa

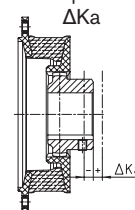

Displacements																
Size	125 HE G125 HE			150 HE G150 HE			200 HE G200 HE			240 HE			275 HE			
	T40 Sh	T50 Sh	T70 Sh	T40 Sh	T50 Sh	T65 Sh	T40 Sh	T50 Sh	T65 Sh	T40 Sh	T50 Sh	T65 Sh	T40 Sh	T50 Sh	T65 Sh	
Perm. radial displacement ΔKr [mm]	n=1500 rpm	2.5	2.3	1.1	2.8	2.5	1.3	3.0	2.7	1.5	3.2	2.9	1.6	3.4	3.1	1.8
	max. ¹⁾	7.5	6.9	3.3	8.0	7.5	4.0	8.5	8.0	4.5	9.0	8.5	5.0	9.5	9.0	5.5
Perm. angular displacement ΔKw [°]	n=1500 rpm	1.0	0.75	0.5	1.0	0.75	0.5	1.0	0.75	0.5	1.0	0.75	0.5	1.0	0.75	0.5
	n=3000 rpm	0.5	0.4	0.25	-	-	-	-	-	-	-	-	-	-	-	-
Perm. angular displacement ΔKw [mm]	max. ¹⁾	1.5			1.5			1.5			1.5			1.5		
Perm. axial displacement ΔKa [mm]	± 3			± 4			± 4			± 4			± 4			

¹⁾ For short-term start-up operation

Mounting procedure, screw type with property class, tightening torques as per KTR assembly instructions (see www.ktr.com).

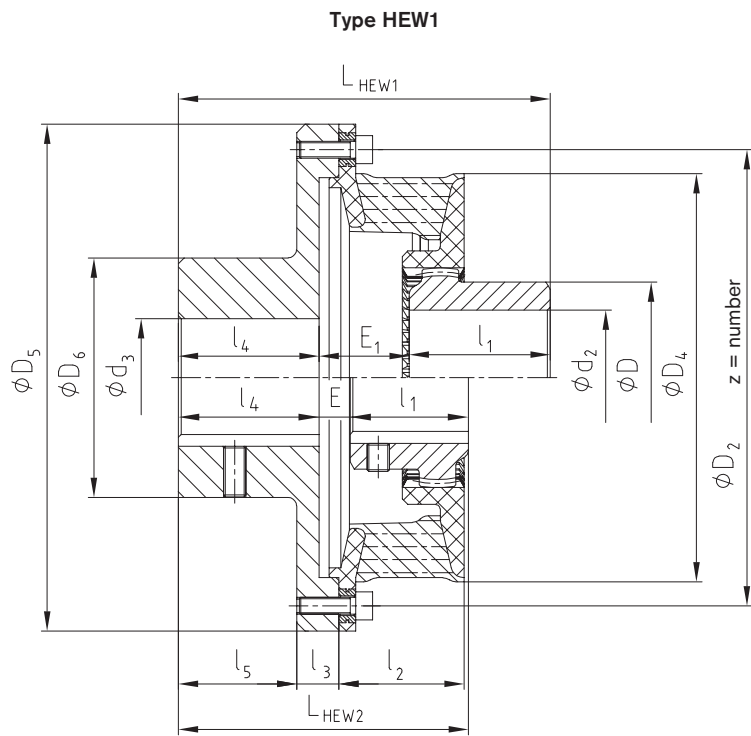
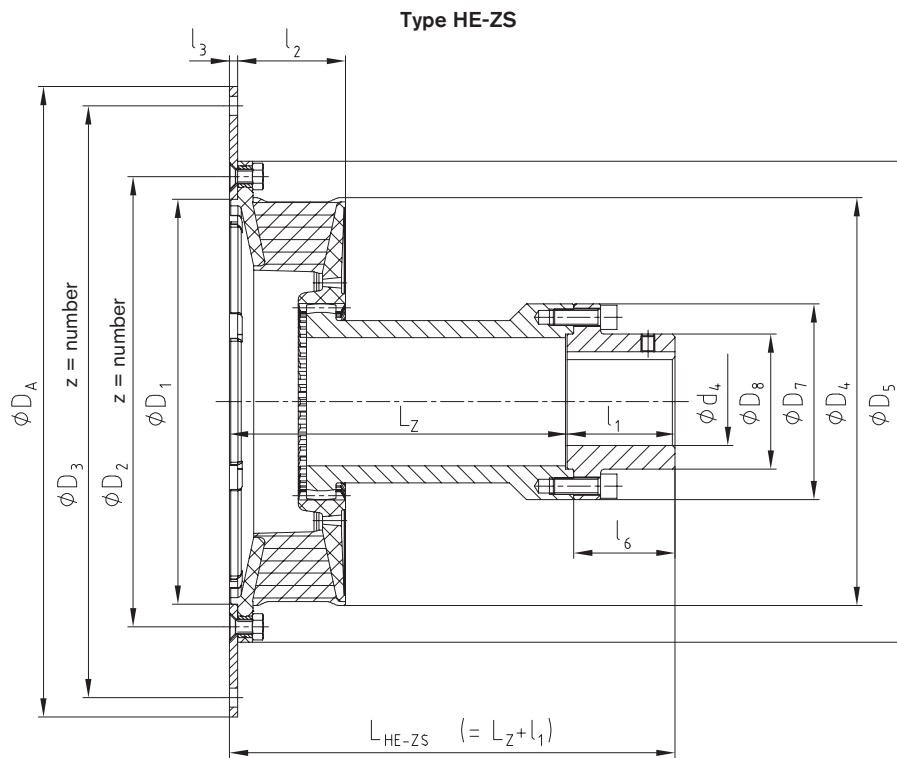

Type HEW2

BoWex-ELASTIC® HEG

Highly flexible flange couplings

Cardan shaft connecting coupling



For legend of pictogram please refer to flapper on the cover

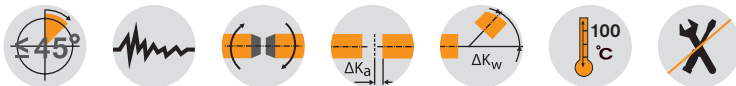

BoWex-ELASTIC® Type HEG1 and type HEG2																															
Size	Flywheel connection acc. to SAE-J620					Metric flange connection HEG1 dimensions [mm]										MECHANICS cardan shaft connection HEG2 dimensions [mm]								Dimensions [mm]			Weight [kg]	Mass moment of inertia			
	8"	10"	11 1/2"	14"	16"	58	65	75	90	100	120	150	180	l ₄	L	2 C	4 C	5 C	6 C	7 C	8,5 C	8 C	L ₁	D ₄	l ₂	l ₃		JA [kgm ²]	JL [kgm ²]		
48 ¹⁾	●					●	●	●						8	58.5										163	43.5	8	7	0.03	0.006	
		●				●	●	●																			8	0.06	0.006		
G 65 ¹⁾		●					●	●	●	●				8	66	●	●	●							71	205	48.0	10	12	0.07	0.02
			●				●	●	●	●						●	●	●									14	0.10	0.02		
80 ¹⁾		●					●	●	●	●				10	88.5		●	●	●						104	265	68.5	23	21	0.11	0.06
			●				●	●	●	●							●	●	●								12	23	0.17	0.06	
G 80 ¹⁾			●				●	●	●	●				10	96		●	●	●		●				110	302	74.0	23	26	0.18	0.09
				●			●	●	●	●							●	●	●		●						12	33	0.48	0.09	
100 ¹⁾				●			●	●	●	●				12	98						●	●			128	350	78.0	16	41	0.63	0.19
125 ²⁾				●			●	●	●	●				12	111							●	●				18	56	0.74	0.42	
					●		●	●	●	●												●	●				12	59	0.97	0.42	

¹⁾ Technical data see page 220

²⁾ Technical data see page 222

Flywheel connection to SAE-J620				
Size	D _A	D ₁	z ₁	d ₁
8"	263.52	244.47	6	11
10"	314.32	295.27	8	11
11 1/2"	352.42	333.37	8	11
14"	466.72	438.15	8	14
16"	517.50	489.00	8	14

Metric flange connection HEG1 [mm]					
Size	D ₂	l ₁	D ₃	z ₂	d ₂
58	30	1.0	47.0	4	M5
65	35	1.0	52.0	4	M6
75	42	1.5	62.0	6	M6
90	47	2.0	74.5	4	M8
100	57	2.0	84.0	6	M8
120	75	2.0	101.5	8	M10
150	90	2.5	130.0	8	M12
180	110	3.0	155.5	8	M14

MECHANICS cardan shaft connection HEG2 [mm]						
Size	D ₅	l ₅	l ₆	l ₇	l ₈	z ₃
2 C	79.35	33.3	59.5	9.50	3.8	M8
4 C	107.92	36.5	87.3	9.50	3.8	M8
5 C	115.06	42.9	88.9	14.26	5.1	M10
6 C	140.46	42.9	114.3	14.26	5.1	M10
7 C	148.39	49.2	117.5	15.85	6.0	M12
8,5 C	165.08	71.4	123.8	15.85	6.0	M12
8 C	206.32	49.2	174.6	15.85	6.0	M12

BoWex-ELASTIC® type HEG has a maintenance-free plain bearing compensating for the radial loads generated by the cardan shaft. Moreover, the coupling has a friction disk which is axially prestressed by the elastomer part. The elastomer part is made of natural rubber via vulcanizing.

The permanent friction provides the coupling with excellent damping properties reducing the high vibratory torques arising in the coupling during the starting process and running through resonance considerably.

Type HEG1

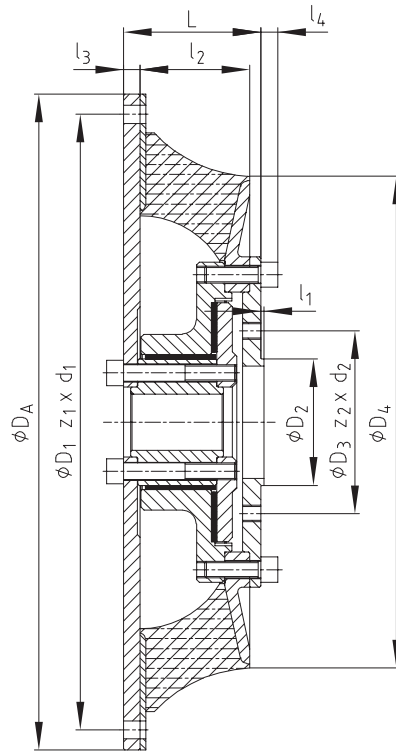

Type HEG2

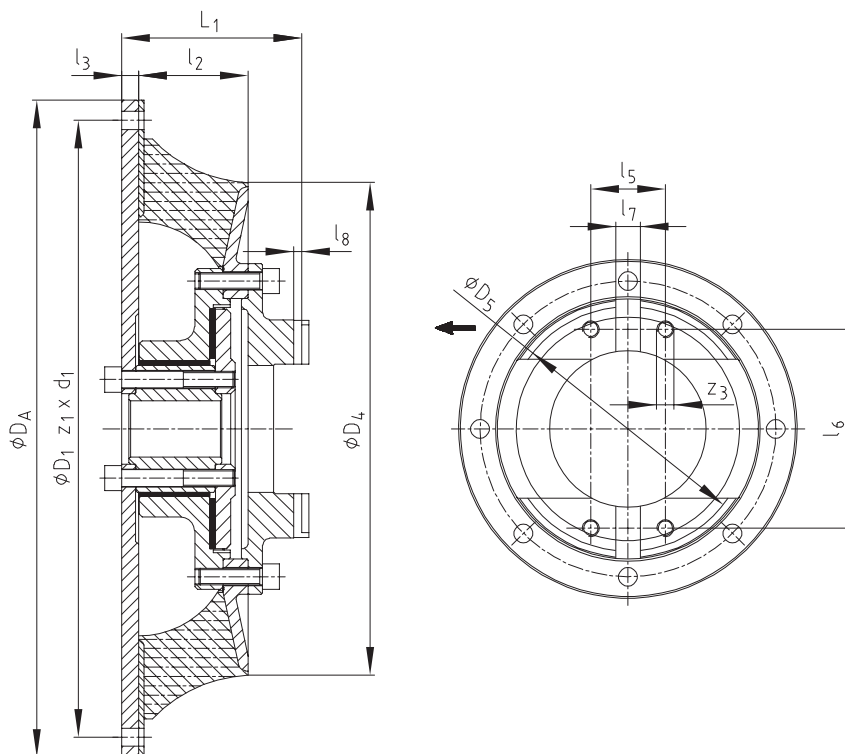



Magnetic couplings

Types and operating description 230

MINEX[®]-S

Containment shroud – material stainless steel	232
Containment shroud – material Hastelloy	234
Containment shroud – material PEEK	236
Containment shroud – material oxide ceramics	238
Conversion kits and customized subassemblies	240
Other types	241



Please note: Higher pressure resistance



Years of experience with applications at customer sites and additional test series in the KTR test field in Rheine enabled us to determine potentials allowing for an increase of pressure resistance with some sizes of this series.

MINEX[®]-S

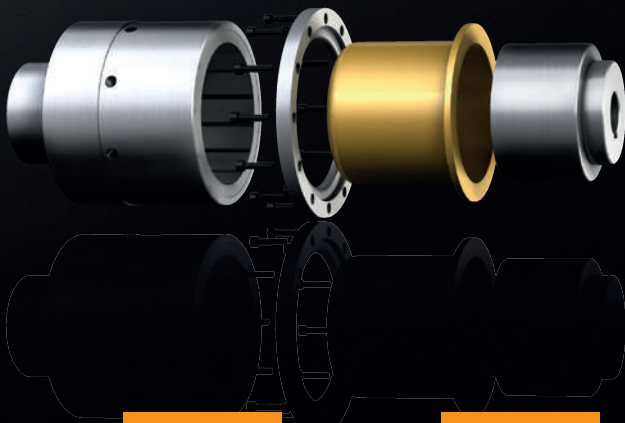

MAGNETIC COUPLINGS

TYPES AND OPERATING DESCRIPTION

General information



General description

MINEX®-S magnetic couplings transmit the torque without contact through magnetic forces between the internal and external rotor. They ensure a hermetic separation between driving and driven side in pumps and agitators sealing critical liquids and gases reliably. As a result they prevent serious leakages operating as a reliable alternative to usual dynamic shaft seals.

Internal rotor



External rotor



Run of flux lines

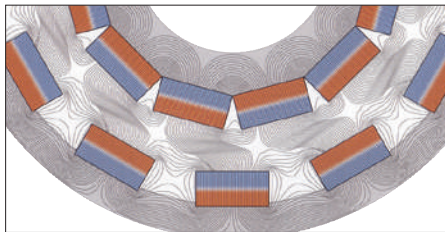

Operation/structure

The coupling consists of an external and an internal rotor. The external rotor has got high-quality, permanent magnets of changing polarity on the inner side and the internal rotor has got them on the outside.

The external rotor is normally fixed on the drive side and the magnets are glued in the keyways. The magnets of the internal rotor on the driven side are fully encapsulated.

Torque transmission

In their non-operative states the north and south poles of the rotors face each other and the magnetic field is completely symmetric. It is only when the rotors are twisted that the magnetic field lines are moved, hence the torque is transmitted through the air gap. Then there is a synchronous operation under a constant torsion angle.

If the maximum coupling torque and the maximum torsion angle are exceeded, the power transmission is interrupted.

Containment shroud



Sealing function

The containment shroud that is fixed to the housing separates internal and external rotor from each other.

It ensures a completely leak-proof separation of product and atmosphere.

The sealing is achieved statically, e. g. with a flat seal or an O-ring, thus eliminating the need to use dynamically loaded sealing elements.

As a standard KTR supplies both metallic and non-metallic containment shrouds.

The metallic types cover the widest application range, yet causing eddy current losses which might require cooling measures.

If eddy current losses can be entirely excluded, the energy-efficient alternative materials PEEK and ceramics are available.



Use in potentially explosive atmospheres

MINEX® couplings are suitable for power transmission in drives in potentially explosive atmospheres. The types with metallic, ceramic and PEEK containment shrouds are assessed and approved as components of category II according to EU directive 2014/34/EU and thus suitable for the use in potentially explosive atmospheres of zone 2G.

Please read through our information included in the respective Type Examination Certificate and the operating and mounting instructions at www.ktr.com.

MAGNETIC COUPLINGS

TYPES AND OPERATING DESCRIPTION

Properties of magnetic couplings

Product	Type with metallic containment shroud	Type with containment shroud made of PEEK CFK	Type with containment shroud made of oxide ceramics
Type	Permanent-magnetic synchronous coupling		
Features			
Permanent-magnetic	●	●	●
Contactless	●	●	●
Maintenance-free	●	●	●
Torsionally flexible	●	●	●
Low vibrations	●	●	●
Special features/applications			
	Most common type Covering the widest performance range Particularly suitable for pump drives/ Applications with liquids High t_{max} [°C] and p_{max} [bar]	No eddy current losses Energy-efficient and economic Particularly suitable for dry running for average requirements on t_{max} [°C] and p_{max} [bar]	High t_{max} [°C] and p_{max} [bar]
Torque range T_{KN} [Nm]			
Max.	1,000	370	550
Max. pressure resistance [bar]			
p_{max} .	Up to 90 bar depending on size	Up to 16 bar with 130 °C	Up to 25 bar depending on size
Geometries			
Shaft diameter min./max. [mm]	Ø5 pilot bored	Ø5 pilot bored	Ø5 pilot bored
Max. temperature resistance [°C]			
t_{max} .	150/300 depending on magnet material	130	300
Certifications/type examinations			
ATEX 	●	CFRP reinforcement ●	GRP reinforcement ●
	For further details see catalogue pages 232 - 235	For further details see catalogue pages 236 - 237	
		For further details see catalogue pages 238 - 239	

Torque reduction with temperature increase

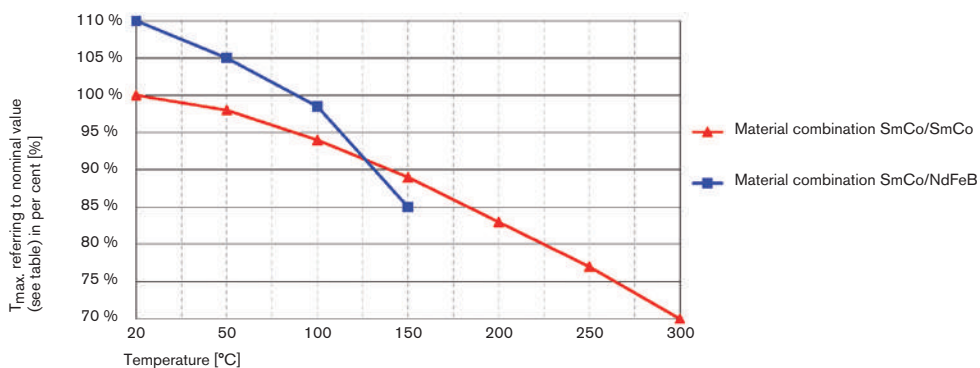

Temporary torque reduction with increased temperature for alternative material combinations [%].

Please note:

KTR recommends to use NdFeB magnets for the external rotor, provided that the operating temperature falls below 150 °C.

MINEX®-S Magnetic couplings

Containment shroud – material stainless steel

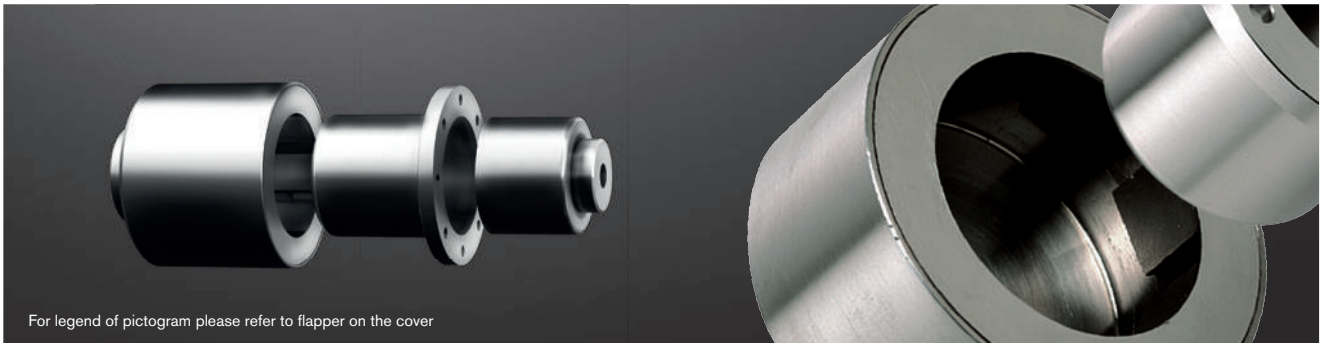

For legend of pictogram please refer to flapper on the cover

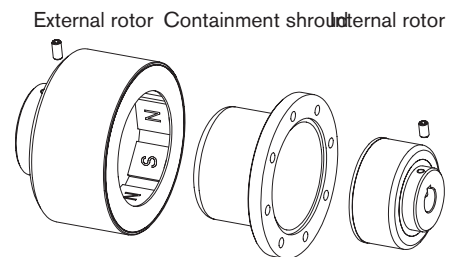
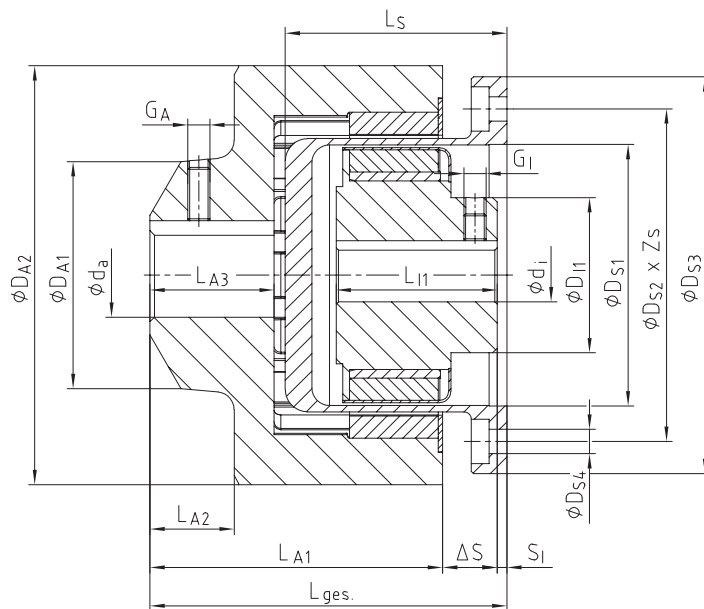

Technical data – Internal rotor and containment shroud

Size	TK max [Nm] with 20 °C	Dimensions [mm]												
		Internal rotor						Containment shroud						
		Finish bore ¹⁾ d _i		D _{I1}	L _{I1}	G _I	S _I		D _{S1}	D _{S2}	D _{S3}	D _{S4}	Z _S	L _S
Min.	Max.	Min.	Max.											
SA 22/4	0.15	5	9	20	20	M3	2.0	2.0	21.5	38	46	4.5	8	29
SA 34/10	1	5	12	20	22	M3	2.0	5.5	34	46	55	4.5	4	30.5
SA 46/6	3	8	16	28	33	M4	6.5	7.0	46	64	78	4.5	8	45
SA 60/8	7	12	22	35	36.3	M5	1.7	5.5	59	75	89	5.5	8	50
SB 60/8	14			36	56	M5	0.0	4.0						70.3

Technical data – External rotor and general

Size	Dimensions [mm]											
	External rotor								General			
	Finish bore ¹⁾ d _a		D _{A1}	D _{A2}	G _A	L _{A1}	L _{A2}	L _{A3}	ΔS	L _{total}		
Min.	Max.	Min.								Max.		
SA 22/4	5	11	18	38	M4	35	8.5	11	5	42	42	
SA 34/10	5	14	22	53	M4	38.8	10.5	13	5.3	46	49.5	
SA 46/6	5	24	40	69.5	M5	53	16	22	9	69	69.5	
SA 60/8	9	32	50	94.5	M6	66	19	28	12	80	83.3	
SB 60/8	9	38			M8	93.3	15	30				105.2

¹⁾ Bores H7 with keyway to DIN 6885 sheet 1 [JS9]

Ordering example:	MINEX® SA 60/8	NdFeB	d _i Ø20 mm	d _a Ø24 mm
	Coupling size	NdFeB – t _{max.} = 150 °C Sm2Co17 – t _{max.} = 300 °C	Finish bore (H7), feather keyway acc. to DIN 6885 sheet 1 (JS9)	

Examples of application

MINEX® couplings with containment shroud made of stainless steel are the most common type for pump drives and other applications with liquids in the lower performance range. Subject to their high resistance to pressure and temperature they cover a wide application range. The magnetic rotors are available from stock in an unbored or pilot bored design. If requested, the parts can be finish bored according to ISO fit H7 and provided with feather keyway to DIN 6885 sheet 1 [JS9].

Inside the rotating magnetic field metallic containment shrouds generally cause losses of eddy current which are converted into heat and which may require cooling measures. On applications with pumps the heat generated can basically be dissipated by the medium to be pumped. If higher pressure resistance than covered by the KTR standard is required, KTR provide for customized special solutions.

Typical applications: gear pumps, centrifugal pumps, screw spindle pumps, agitators, PU foaming lines

Use in potentially explosive atmospheres

MINEX® couplings with containment shroud made of stainless steel are suitable for power transmission in drives in potentially explosive atmospheres. They are assessed and approved as components of category II according to EU directive 2014/34/EU and thus suitable for the use in potentially explosive atmospheres of zone 2G.

 II 2G c IIC T X

If the couplings operate in potentially explosive atmospheres, the user has to provide for special measures. Please read through our information included in the respective Type Examination Certificate and the operating and assembly instructions at www.ktr.com.



Technical data – Materials, temperature and pressure resistance

Size	TK max [Nm] with 20 °C	Internal rotor			Containment shroud			External rotor (+ flange hub optionally)		
		Standard material		Max. temperature	Standard material		Max. pressure	Standard material		Max. temperature
		Hub	Magnets	t _{max.} [°C]	Hub	Cont. shroud	P _N /P _{max.} [bar]	Hub	Magnets	t _{max.} [°C]
SA 22/4	0.15	1.4462	NdFeB	150	1.4571	1.4571	60/90	S355J2	NdFeB	150
SA 34/10	1	1.4462	NdFeB	150	1.4571	1.4571	16/24	S355J2	NdFeB	150
SA 46/6	3	1.4571	Sm2Co17	300	1.4571	1.4571	16/24	S355J2	Sm2Co17	300
SA 60/8	7	1.4571	Sm2Co17	300	1.4571	1.4571	40/60	S355J2	Sm2Co17*	300
SB 60/8	14	1.4571	Sm2Co17	300	1.4571	1.4571	40/60	S355J2	Sm2Co17*	300

*) External rotor alternatively available with magnets made of NdFeB (t_{max.} = 150 °C)

MINEX®-S Magnetic couplings

Containment shroud – material Hastelloy

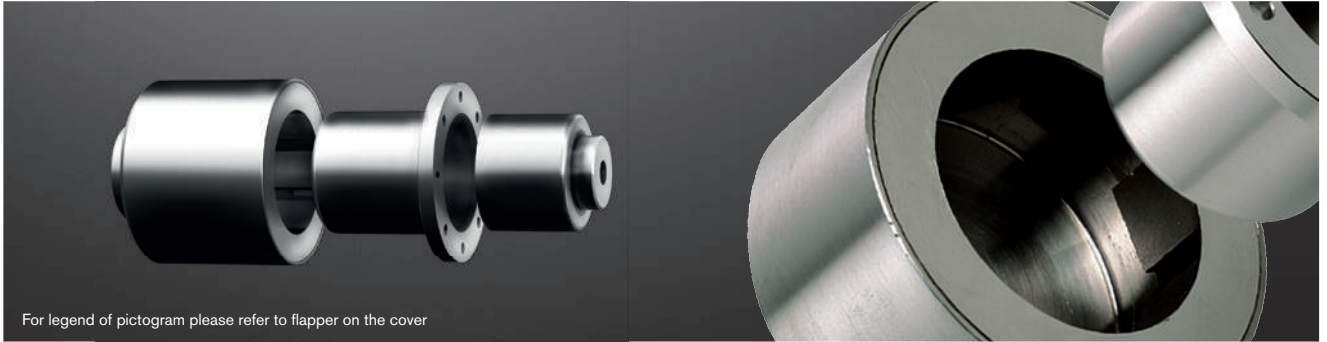

For legend of pictogram please refer to flapper on the cover

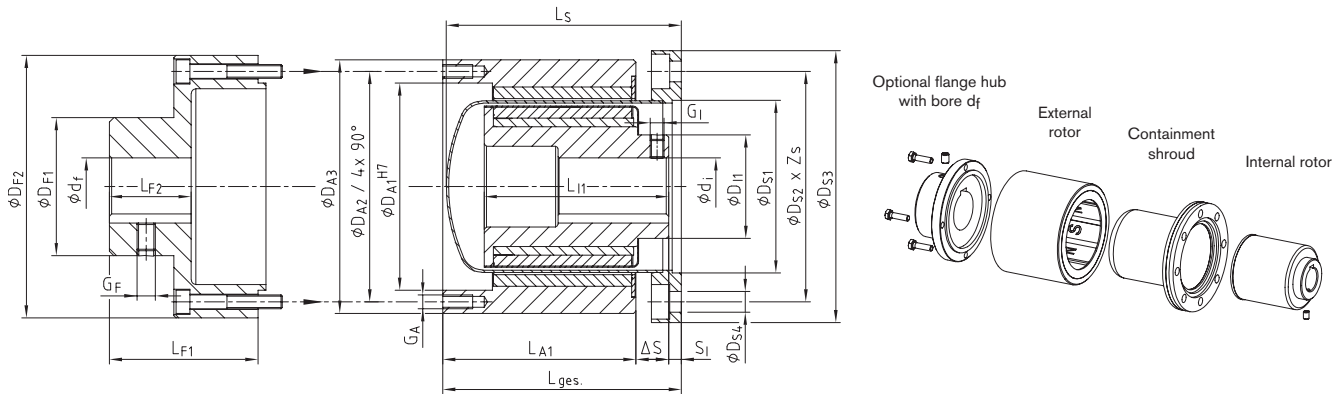

Technical data – Materials, temperature and pressure resistance

Size	TK max [Nm] with 20 °C	Internal rotor		Containment shroud			External rotor (+ flange hub optionally)			
		Standard material		Max. temperature	Standard material		Max. pressure	Standard material		Max. temperature
		Hub	Magnets	t _{max.} [°C]	Hub	Cont. shroud	P _N /P _{max.} [bar]	Hub	Magnets	t _{max.} [°C]
SA 75/10	10	1.4571	Sm2Co17	300	1.4571	2.4602**	25/37.5	S355J2	Sm2Co17*	300
SB 75/10	24	1.4571	Sm2Co17	300	1.4571	2.4602**	25/37.5	S355J2	Sm2Co17*	300
SC 75/10	40	1.4571	Sm2Co17	300	1.4571	2.4602**	25/37.5	S355J2	Sm2Co17*	300
SA 110/16	25	1.4571	Sm2Co17	300	1.4571	2.4856	25/37.5	S355J2	Sm2Co17*	300
SB 110/16	60	1.4571	Sm2Co17	300	1.4571	2.4856	25/37.5	S355J2	Sm2Co17*	300
SC 110/16	95	1.4571	Sm2Co17	300	1.4571	2.4856	25/37.5	S355J2	Sm2Co17*	300
SB 135/20	100	1.4571	Sm2Co17	300	1.4571	2.4856	25/37.5	S355J2	Sm2Co17*	300
SC 135/20	145	1.4571	Sm2Co17	300	1.4571	2.4856	25/37.5	S355J2	Sm2Co17*	300
SD 135/20	200	1.4571	Sm2Co17	300	1.4571	2.4856	25/37.5	S355J2	Sm2Co17*	300
SC 165/24	210	1.4571	Sm2Co17	300	1.4571	2.4856	25/37.5	S355J2	Sm2Co17*	300
SD 165/24	280	1.4571	Sm2Co17	300	1.4571	2.4856	25/37.5	S355J2	Sm2Co17	300
SE 165/24	370	1.4571	Sm2Co17	300	1.4571	2.4856	25/37.5	S355J2	Sm2Co17	300
SD 200/30	430	1.4571	Sm2Co17	300	1.4571	2.4856	16/24	S355J2	Sm2Co17	300
SE 200/30	550	1.4571	Sm2Co17	300	1.4571	2.4856	16/24	S355J2	Sm2Co17	300
SD 250/38	670	1.4571	Sm2Co17	300	1.4571	2.4856	16/24	S355J2	Sm2Co17	300
SE 250/38	820	1.4571	Sm2Co17	300	1.4571	2.4856	16/24	S355J2	Sm2Co17	300
SF 250/38	1000	1.4571	Sm2Co17	300	1.4571	2.4856	16/24	S355J2	Sm2Co17	300

*) External rotor alternatively available with magnets made of NdFeB (t_{max.} = 150 °C)

***) Containment shroud size 75 alternatively available made of stainless steel 1.4571 (P_N/P_{max.} = 16/24 bar)

Ordering example:	MINEX® SB 75/10	NdFeB	d _i Ø20 mm	d _a Ø24 mm	Hastelloy
	Coupling size	NdFeB – t _{max.} = 150 °C Sm2Co17 – t _{max.} = 300 °C	Finish bore (H7), feather keyway acc. to DIN 6885 sheet 1 (JS9)	Containment shroud type stainl. steel 1.4571 or Hastelloy	

Examples of application

MINEX® couplings with containment shroud made of Hastelloy are the most common type for pump drives and other applications with liquids in the average and higher performance range. Subject to their high resistance to pressure and temperature they cover a wide application range.

Inside the rotating magnetic field metallic containment shrouds generally cause losses of eddy current which are converted into heat and which may require cooling measures. On applications with pumps the heat generated can basically be dissipated by the medium to be pumped. If higher pressure resistance than covered by the KTR standard is required, KTR provide for customized special solutions.

Typical applications: gear pumps, centrifugal pumps, screw spindle pumps, agitators, PU foaming lines

Use in potentially explosive atmospheres

MINEX® couplings with containment shroud made of Hastelloy are suitable for power transmission in drives used in potentially explosive atmospheres. They are assessed and approved as components of category II according to EU directive 2014/34/EU and thus suitable for the use in potentially explosive atmospheres of zone 2G.

⊕ II 2G c IIC T X

If the couplings operate in potentially explosive atmospheres, the user has to provide for special measures. Please read through our information included in the respective Type Examination Certificate and the operating and assembly instructions at www.ktr.com.



Technical data – External rotor and general																												
Size	Dimensions [mm]																											
	Internal rotor						Containment shroud						External rotor					Flange hub				General						
	Finish bore ¹⁾		D _{I1}	L _{I1}	G _I	S _I		D _{S1}	D _{S2}	D _{S3}	D _{S4}	Z _S	L _S	D _{A1}	D _{A2}	D _{A3}	L _{A1}	G _A	d _f max.	D _{F1}	D _{F2}	L _{F1}	L _{F2}	G _F	ΔS	Total length ²⁾ (with flange hub)		
	d _i min.	d _i max.				Min.	Max.																			Min.	Max.	
SA 75/10			39.5			46.5											41.3								12.2	140	164.5	
SB 75/10	12	32	45	58	M6	4	26.5	75	100	118	9	8	102	90	100	110	61.3	M6	42	60	114	64.5	35.5	M8	14.2	166.5	166.5	
SC 75/10			80			4.0											83.8											
SA 110/16			45			55.0											41.3										177.5	
SB 110/16	14	55	80	65	M8	4	35.0	110	133	153	9	12	115	126	135	145	61.3	M6	55	85	150	99.5	59.5	M10	18.7	183.5	214.5	
SC 110/16			85			15.0											81.3										203.5	
SB 135/20			65			50.5											70.3											
SC 135/20	20	70	90	85	M10	4	30.5	135	158	178	9	16	139	150	160	170	90.3	M6	70	100	170	65.5	48.5	M12	18.2	190.5	204.5	
SD 135/20			110			8.0											110.3										20.7	200.5
SC 165/24			85			61.5											90.3										18.2	
SD 165/24	24	80	110	110	M12	6	39.0	163.5	192	218	11	12	170	180	188	198	110.3	M6	75	110	198	77	60	M16	20.7	233	247	
SE 165/24			130			19.0											130.3											234
SD 200/30			135			24.0											130.3											
SE 200/30	38	90	130		M16	6		200	252	278	11	12	180	212	222	232		M6	80	120	232	120	98	M12	25.7	282	300	
SD 250/38			115			46.0											110.3											282
SE 250/38	38	100	165	135	M16	6	26.0	255	285	315	13.5	12	182	272	282	292	130.3	M6	100	150	300	140	93	M16	25.7	302	322	
SF 250/38			155			6.0											150.3											322

¹⁾ Bores H7 with keyway to DIN 6885 sheet 1 [JS9]

²⁾ Total length without flange hub = L_S

MINEX®-S Magnetic couplings

Containment shroud – material PEEK

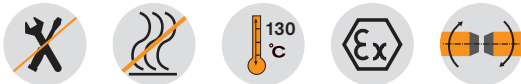
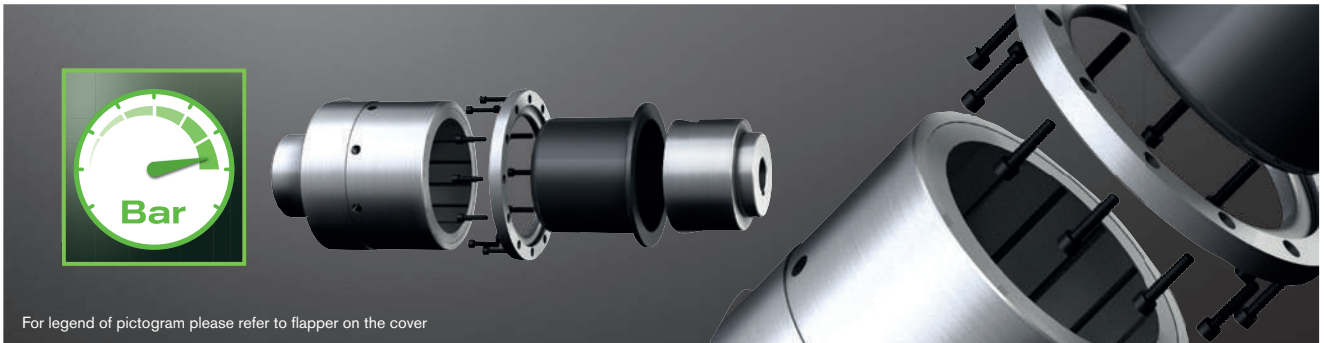

Technical data – Internal rotor and containment shroud															
Size	TK max [Nm] with 20 °C	Dimensions [mm]													
		Internal rotor						Containment shroud							
		Finish bore ¹⁾ d _f		D _{I1}	L _{I1}	G _I	S _I		D _{S1}	D _{S2}	D _{S3}	D _{S4}	Z _S	L _S = L _{total}	
Min.	Max.	Min.	Max.												
SA 75/10	10				39.5		30.5	54.5							
SB 75/10	24	12	32	45	58	M6	8.5	35.5	-	100	118	9	8	108	
SC 75/10	40				80		5.5	13.5							
SA 110/16	30				45		17.9	45							
SB 110/16	70	14	55	80	65	M8	4	25	140	151	168	9	12	115	
SC 110/16	100				85		2	5							
SB 135/20	110				65		38.5	48							
SC 135/20	155	20	70	90	85	M10	18.5	28	157	167	180	6.6	12	144	
SD 135/20	210				110		4	4							
SC 165/24	220				85			32							
SD 165/24	300	24	80	110	110	M12	4	8	196	210	228	9	12	156	
SE 165/24	390				130		-6	-6						165	

Technical data – External rotor, flange hub and general															
Size	Dimensions [mm]														
	External rotor					Flange hub						General			
	DA1	DA2	DA3	LA1	GA	Max. finish bore ¹⁾ d _f	DF1	DF2	LF1	LF2	GF	ΔS	Total length ²⁾ (with flange hub)		
													Min.	Max.	
SA 75/10				41.3											
SB 75/10	90	100	110	61.3	M6	42	60	114	64.5	35.5	M8	12.2	148.5	172.5	
SC 75/10				83.8								14.2	168	172.5	
SA 110/16				41.3									165.5	193.5	
SB 110/16	130	138	150	61.3	M6	55	85	153	87.5	45.5	M10	18.7	172.5	193.5	
SC 110/16				81.3									191.5	193.5	
SB 135/20				70.3									216	225.5	
SC 135/20	158	167	176	90.3	M6	70	100	176	89	67	M12	18.2	216	225.5	
SD 135/20				110.3								20.7	224	224	
SC 165/24				90.3								18.5	231	234.8	
SD 165/24	186	195	204	110.3	M6	75	110	204	94	70	M16	21	231	233.3	
SE 165/24				130.3									254.3	254.3	

¹⁾ Bores H7 with keyway to DIN 6885 sheet 1 [JS9] ²⁾ Total length without flange hub = L_S

Technical data											
Size	TK max [Nm] with 20 °C	Internal rotor				Containment shroud				External rotor (+ flange hub optionally)	
		Standard material		Standard material		Max. pressure		Max. temperature		Standard material	
		Hub	Magnets	Clamping ring	Cont. shroud	P _N [bar]	t _{max.} [°C]	Hub	Magnets		
SA 75/10	10	1.4571	Sm2Co17	-	PEEK	16	130	S355J2	NdFeB		
SB 75/10	24	1.4571	Sm2Co17	-	PEEK	16	130	S355J2	NdFeB		
SC 75/10	40	1.4571	Sm2Co17	-	PEEK	16	130	S355J2	NdFeB		
SA 110/16	30	1.4571	Sm2Co17	Aluminium	PEEK	16	130	S355J2	NdFeB		
SB 110/16	70	1.4571	Sm2Co17	Aluminium	PEEK	16	130	S355J2	NdFeB		
SC 110/16	100	1.4571	Sm2Co17	Aluminium	PEEK	16	130	S355J2	NdFeB		
SB 135/20	110	1.4571	Sm2Co17	Aluminium	PEEK	16	130	S355J2	NdFeB		
SC 135/20	155	1.4571	Sm2Co17	Aluminium	PEEK	16	130	S355J2	NdFeB		
SD 135/20	210	1.4571	Sm2Co17	Aluminium	PEEK	16	130	S355J2	NdFeB		
SC 165/24	220	1.4571	Sm2Co17	Aluminium	PEEK	16	130	S355J2	NdFeB		
SD 165/24	300	1.4571	Sm2Co17	Aluminium	PEEK	16	130	S355J2	NdFeB		
SE 165/24	390	1.4571	Sm2Co17	Aluminium	PEEK	16	130	S355J2	NdFeB		

■ = Years of experience with applications at customer sites and additional test series in the KTR test field in Rheine enabled us to determine potentials allowing for an increase of the pressure resistance with some sizes of this series.

Ordering example:	MINEX® SB 75/10	NdFeB	d _i Ø20 mm	d _a Ø24 mm	PEEK
	Coupling size	NdFeB – t _{max.} = 150 °C	Finish bore (H7), feather keyway acc. to DIN 6885 sheet 1 (JS9)		Containment shroud type

Examples of application

MINEX® couplings with containment shroud made of PEEK are an economic, energy-efficient alternative to the metallic types. They do not generate any eddy current losses and as a result do not generate any heat so that usually expensive cooling measures can be done without. Moreover, they are characterized by low susceptibility to fracture, low weight and easy handling.

They are ideally suitable for applications with low demands on temperature and pressure resistance.

Typical applications: vacuum pumps, fan drives, compressors, agitators, PU foaming lines

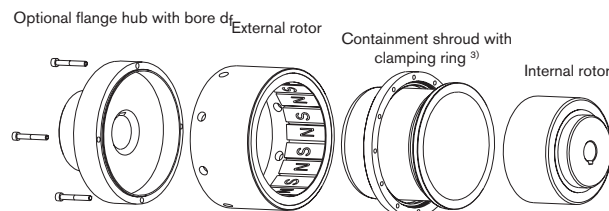
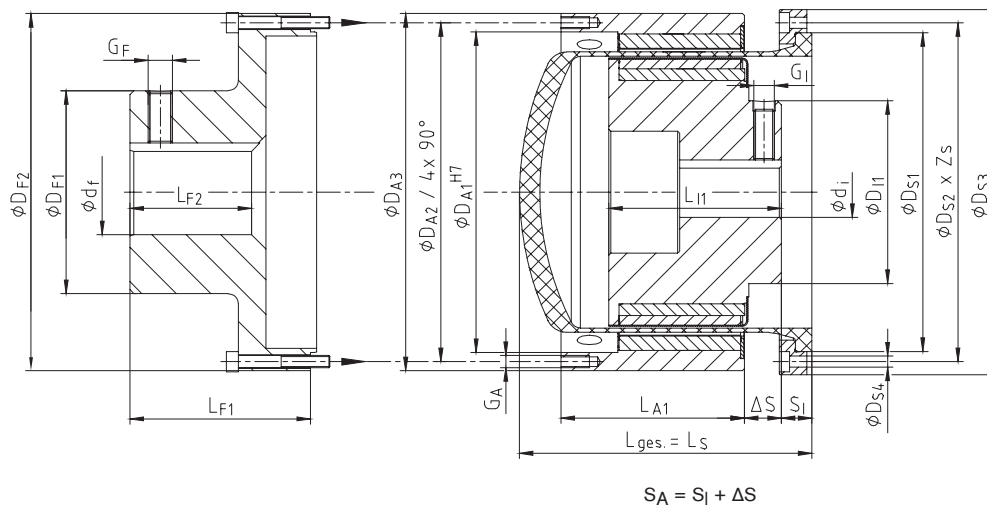

³⁾ Containment shroud size 75 also available as a one-piece design!

Use in potentially explosive atmospheres

MINEX® couplings with containment shrouds made of carbon fibre reinforced PEEK are suitable for power transmission in drives in potentially explosive atmospheres. They are assessed and approved as components of category II according to EU directive 2014/34/EU and thus suitable for the use in potentially explosive atmospheres of zone 2G.

 II 2G c IIC T X

If the couplings operate in potentially explosive atmospheres, the user has to provide for special measures. Please read through our information included in the respective Type Examination Certificate and the operating and assembly instructions at www.ktr.com.



MINEX®-S

Magnetic couplings

Containment shroud – material oxide ceramics

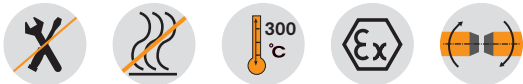
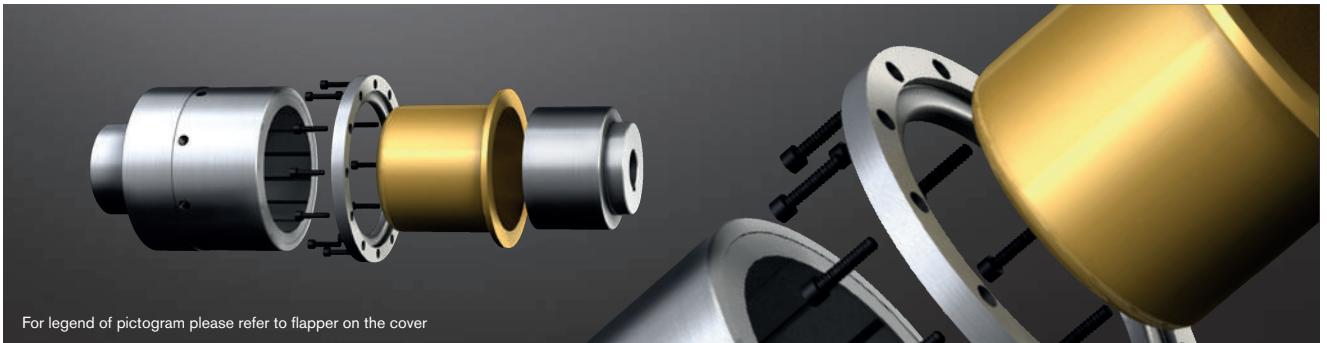

Technical data – Internal rotor and containment shroud

Size	TK max [Nm] with 20 °C	Dimensions [mm]												
		Internal rotor						Containment shroud						
		Finish bore ¹⁾ d _f		D _{I1}	L _{I1}	G _I	S _I		D _{S1}	D _{S2}	D _{S3}	D _{S4}	Z _S	L _S = L _{total}
Min.	Max.	Min.	Max.											
SA 110/16	30				45									
SB 110/16	70	14	55	72	65	M8	4	28.0	132	151	168	9	12	115
SC 110/16	100				85			9.0						
SB 135/20	110				65			46.5						
SC 135/20	155	20	70	90	85	M10	4	26.5	157	167	180	5.5	12	143
SD 135/20	210				110			4.0						
SC 165/24	220				85			28.0						
SD 165/24	300	24	90	110	110	M12	4	4.0	196	210	225	6.6	12	150
SE 165/24	390				130			17.0						185
SD 200/30	430													
SE 200/30	550	38	90	130	135	M16	4	4.0	229	246	265	9	12	185

Technical data – External rotor, flange hub and general

Size	Dimensions [mm]											General		
	External rotor					Flange hub						ΔS	Total length ²⁾ (with flange hub)	
	DA1	DA2	DA3	LA1	GA	Max. finish bore ¹⁾ d _f	DF1	DF2	LF1	LF2	GF		Min.	Max.
SA 110/16				41.3									165.5	195.5
SB 110/16	130	138	150	61.3	M6	55	85	153	87.5	45.5	M10	18.7	171.5	195.5
SC 110/16				81.3									191.5	196.5
SB 135/20				70.3									215	224
SC 135/20	158	167	176	90.3	M6	70	100	176	89	67	M12	18.2	215	224
SD 135/20				110.3								20.7	220	220
SC 165/24				90.3								18.5	225	230.5
SD 165/24	186	195	204	110.3	M6	75	110	204	94	70	M16	20.7	229	229
SE 165/24				130.3									260	260
SD 200/30														
SE 200/30	220	230	240	130.3	M6	80	120	240	120	88	M16	25.7	280	280

¹⁾ Bores H7 with keyway to DIN 6885 sheet 1 [JS9]

²⁾ Total length without flange hub = L_S

Technical data

Size	TK max [Nm] with 20 °C	Internal rotor			Containment shroud			External rotor (+ flange hub optionally)		
		Standard material		Max. temperature	Standard material		Max. pressure	Standard material		Max. temperature
		Hub	Magnets	t _{max.} [°C]	Hub	Cont. shroud	P _N /P _{max.} [bar]	Hub	Magnets	t _{max.} [°C]
SA 110/16	25	1.4571	Sm2Co17	300	Aluminium	ZrO2MgO	25/37.5	S355J2	Sm2Co17	300
SB 110/16	60	1.4571	Sm2Co17	300	Aluminium	ZrO2MgO	25/37.5	S355J2	Sm2Co17	300
SC 110/16	95	1.4571	Sm2Co17	300	Aluminium	ZrO2MgO	25/37.5	S355J2	Sm2Co17	300
SB 135/20	100	1.4571	Sm2Co17	300	Aluminium	ZrO2MgO	25/37.5	S355J2	Sm2Co17	300
SC 135/20	145	1.4571	Sm2Co17	300	Aluminium	ZrO2MgO	25/37.5	S355J2	Sm2Co17	300
SD 135/20	200	1.4571	Sm2Co17	300	Aluminium	ZrO2MgO	25/37.5	S355J2	Sm2Co17	300
SC 165/24	210	1.4571	Sm2Co17	300	Aluminium	ZrO2MgO	25/37.5	S355J2	Sm2Co17	300
SD 165/24	280	1.4571	Sm2Co17	300	Aluminium	ZrO2MgO	25/37.5	S355J2	Sm2Co17	300
SE 165/24	370	1.4571	Sm2Co17	300	Aluminium	ZrO2MgO	25/37.5	S355J2	Sm2Co17	300
SD 200/30	430	1.4571	Sm2Co17	300	Aluminium	ZrO2MgO	25/37.5	S355J2	Sm2Co17	300
SE 200/30	550	1.4571	Sm2Co17	300	Aluminium	ZrO2MgO	25/37.5	S355J2	Sm2Co17	300

Ordering example:

MINEX® SB 135/20	NdFeB	d _i Ø20 mm	d _a Ø24 mm	Oxide ceramics ZrO ₂ MgO
Coupling size	NdFeB – t _{max.} = 150 °C Sm2Co17 – t _{max.} = 300 °C	Finish bore (H7), feather keyway acc. to DIN 6885 sheet 1 (JS9)		Containment shroud type

Examples of application

Like with the types with containment shroud made of PEEK, MINEX® couplings with containment shroud made of ceramics are an economic, energy-efficient alternative to the metallic types. Again they do not generate any eddy current losses and as a result do not generate any heat so that usually expensive cooling measures can be done without. Compared to PEEK, the containment shrouds made of ceramics are characterized by higher resistance to pressure and an excellent temperature resistance.

Typical applications: vacuum pumps, fan drives, compressors, agitators, PU foaming lines

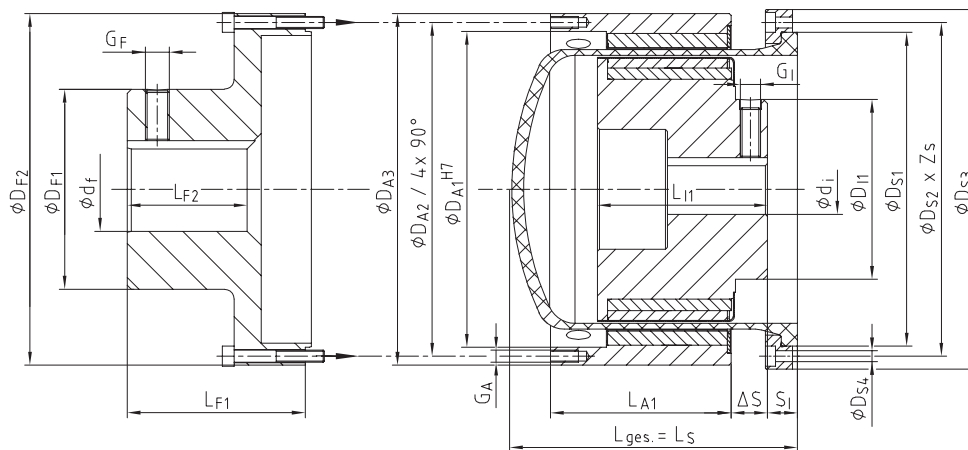

Optional flange hub with bore d_f

External rotor

Containment shroud with clamping ring

Internal rotor

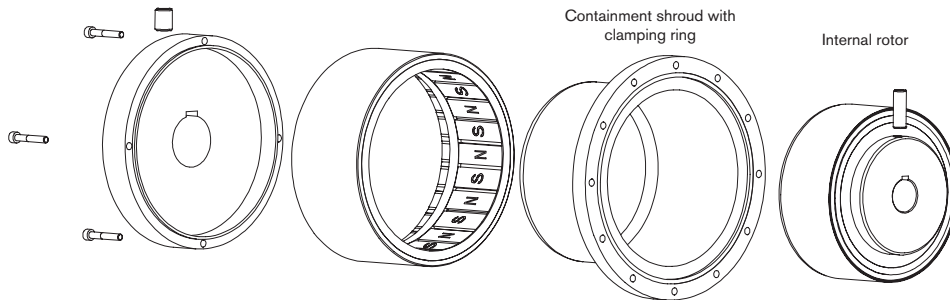

Use in potentially explosive atmospheres

MINEX® couplings with containment shrouds made of oxide ceramics are suitable for power transmission in drives in potentially explosive atmospheres. They are assessed and approved as components of category II according to EU directive 2014/34/EU and thus suitable for the use in potentially explosive atmospheres of zone 2G.

 II 2G c IIC T X

Please read through our information included in the respective Type Examination Certificate and the operating and assembly instructions at www.ktr.com.



MINEX®-S Magnetic couplings

Conversion kits and customized subassemblies

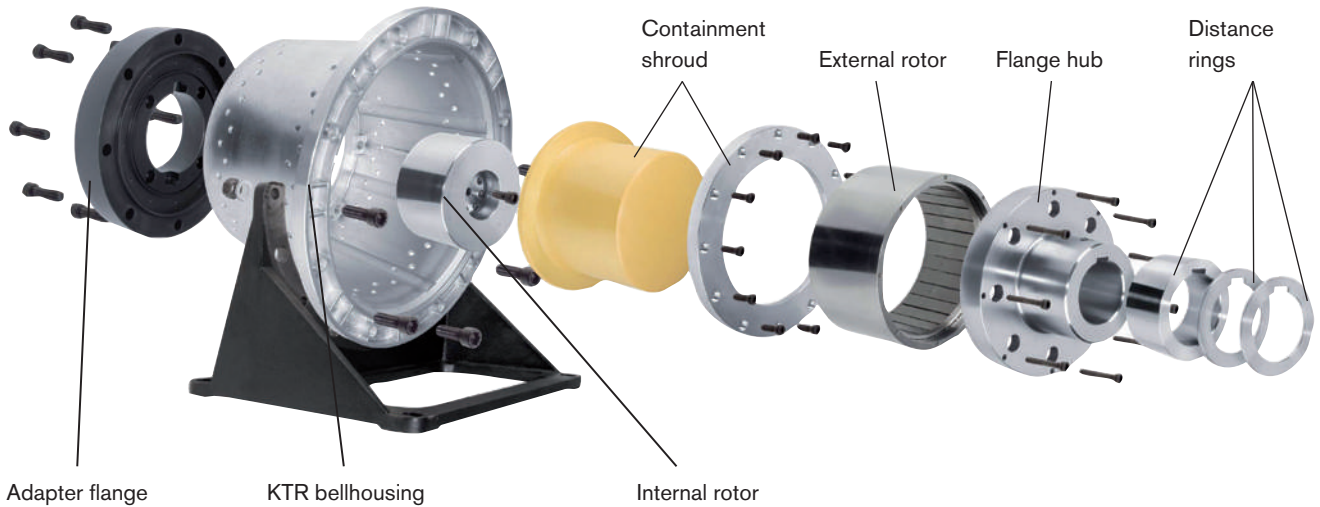

On request KTR provide customized solutions in combination with KTR hydraulic components, allowing to easily retrofit existing systems by MINEX®-S.

Conversion kits for PUR foaming processes

When conveying and proportioning the media polyol and isocyanate in the processing plants for PUR, ambient air has to be prevented from penetrating into the process, since otherwise adverse reactions may be generated.

For a reliable sealing of such drives KTR provides standard conversion kits, among others for axial piston pumps type REXROTH A2VK and ROTARY POWER C series offering the following benefits:

- Maintenance-free operation
- Standstill periods are considerably reduced
- No more problems with sealing
- Better efficiency and process reliability

The subassemblies are available for all motor-pump-combinations and in various materials.

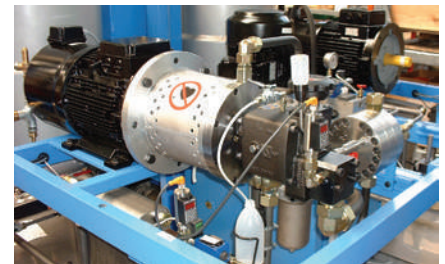



Maintenance-free sealing of proportioning pumps for polyde and isocyanate in high-pressure reaction moulding machines

Pump data		Motor data (4 poles, n=1500 rpm)			Coupling data		
Pump	Type	Engine	Power [kW]	Torque TN	Size	Max. torque TK max	Bellhousing
	A2VK-12	132 S	5.5	35 Nm	SB 110/16	60 Nm	PL 300/13/...
		132 M	7.5	48 Nm	SC 110/16	95 Nm	
		160 M	11	70 Nm	SC 135/20	145 Nm	
REXROTH A2VK	A2VK-28	160 M	11	70 Nm	SC 135/20	145 Nm	PL 350/7/...
		160 L	15	96 Nm	SD 135/20	200 Nm	
	A2VK-55	180 M	18.5	118 Nm	SD 135/20	200 Nm	PL 350/7/...
		160 L	15	96 Nm	SC 165/24	210 Nm	
		180 M	18.5	118 Nm	SC 165/24	210 Nm	
	A2VK-107	180 L	22	144 Nm	SD 165/24	280 Nm	PL350/7/...
		200 L	30	196 Nm	SE 165/24	280 Nm	PL400/5/...
		225 S/M	37/45	240/292 Nm	SE 165/24	370 Nm	PL450/3/...
ROTARY POWER C-Range	C 01	100L	2.2	14 Nm	SB 75/10	24 Nm	PK 250/13/...
		132 M	7.5	48 Nm	SC 110/16	95 Nm	PL300/13/...
	C 07	132 S	5.5	35 Nm	SB 110/16	60 Nm	PL300/13/...
		132 M	7.5	48 Nm	SC 110/16	95 Nm	PL300/13/...
	C20	160 L	15	96 Nm	SD 135/20	200 Nm	PL 350/7/...
		180 M	18.5	118 Nm	SD 135/20	200 Nm	PL 350/7/...

MINEX®-S Magnetic couplings

Other types

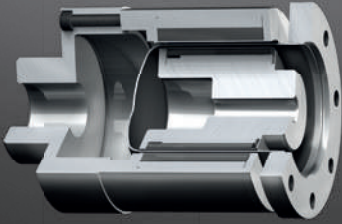
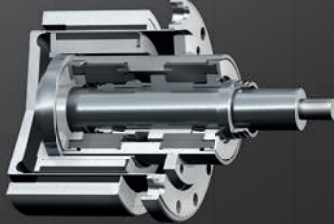
	
<p>Disk coupling With this type the magnets are arranged opposite each other in axial direction. This type becomes relevant if is only little axial mounting space and a flat separating wall between the rotors is requested.</p>	<p>Hysteresis coupling MINEX®-H Different from the MINEX®-S magnetic coupling this type switches to slipping operation once the maximum transmittable torque has been achieved, while it continues to transmit T_{max} as a holding torque. Applications: roller conveyors, winder drives, etc.</p>
	
<p>MINEX®-S fully made of stainless steel If requested, KTR supplies MINEX®-S fully made of stainless steel. The magnets of the external rotor are encapsulated just like with the internal rotor. Applications: roller conveyors, winder drives, etc.</p>	<p>Customized special solutions If requested, KTR supplies MINEX®-S in combination with the slide bearing required for the driven shaft.</p>

Use of MINEX®-S on a small centrifugal pump



MINEX®-S for sealing homogenizers for heavy oil processing in marine operation

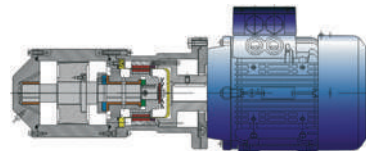

Retrofitting of a gear pump with MINEX® SA 75/10, bellhousing PK 200/30, foot flange and damping rod



MINEX®-S for sealing of autoclaves (T.B.M./STERICHEM) in laboratories and hospitals

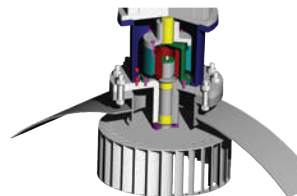

Technical data for coupling selection/selection of components

Motor type	_____	Pump type	_____
Driving power	_____ kW	Speed	_____ rpm
Pressure	_____ bar	Temperature	_____ °C
Viscosity of medium	_____ mm ² /s	Max. perm. dimensions	_____ ØD x L _{total}



Torque limiters

Types and operating description	244
Selection of torque limiters	245

RUFLEX®		SYNTEX®	
Structure and operation	246	Structure and operation	262
Standard	247	Operating principles	263
With sprocket	248	Flange type	264
Max. type	249	With sprocket	266
With torsionally flexible ROTEX®	250	With toothed belt pulley	268
With torsionally rigid BoWex®	251	With backlash-free ROTEX® GS	269

KTR-SI		SYNTEX®-NC / KTR-SI Compact	
Structure and operation	252	SYNTEX®-NC	270
Operating principles	255	Hub design	272
KTR-SI flange type	256	With backlash-free ROTEX® GS	273
KTR-SI with torsionally flexible ROTEX®	257	With torsionally rigid TOOLFLEX® S	274
KTR-SI FRE flange type	258		
KTR-SI FRE with torsionally flexible ROTEX®	259		
KTR-SI FRA flange type FT	260	KTR-SI Compact	
KTR-SI FRA with torsionally flexible POLY-NORM®	261	Flange type	275
		With backlash-free ROTEX® GS	276

RUFLEX®

KTR-SI

SYNTEX®

SYNTEX®-NC

KTR-SI Compact



TORQUE LIMITERS

TYPES AND OPERATING DESCRIPTION

Properties of torque limiters

							
Product	RUFLEX®	KTR-SI	KTR-SI FRE	KTR-SI FRA	SYNTEX®	SYNTEX®-NC	KTR-SI Compact
Type	Torque limiter	Overload system	Overload system	Overload system	Backlash-free overload system		
Torque limitation							
Friction (load-retaining)	●						
Ratchet coupling		●	●	●	●	●	●
Synchronous ratcheting SK/SR (load-separating)		●			●	●	●
Ratcheting DK (load-separating)		●			●	●	●
Idle rotation FR/FRE/FRA (load-separating)		●	●	●			
Fail-safe SGR (no mechanical separation)		●					
Features							
Backlash-free					●	●	●
High repeatability		●	●	●	●	●	●
Quick separation with overload						●	●
Signal by limit switch/sensor		●	●	●	●	●	●
Torque setting while in place	●	●	●	●	●	●	●
Torque range T_{KN} [Nm]							
min. - max.	0.5 - 12,000	2.5 - 8,200	1,000 - 60,000 (and above)	5 - 3,000	6 - 400	2 - 550	3 - 3,100
Max. bore [mm]							
	140	100	200 (and above)	80	50	60	80
Shaft-hub-connection							
Positive locking	●	●	●	●	●	●	●
Frictionally engaged			●		●	●	●
Speed n_{max} [rpm]							
	10,000	6,000	3,300	3,600	1,500	3,500	4,000
Special features							
	High power density, low price	Hardened surfaces, solid design	Modular design, for high torques	Re-engagement by reversing the direction of rotation	For tailor-made solutions, low cost, ideally suitable for bigger quantities	High power density, light-weight design	Hardened surfaces, solid design
Applications							
	Slowly rotating drives such as sprocket or toothed belt drives, conveyors, rotary feeders, ...	Rugged drive situations, e. g. crushers, ...	Shredders, extruders, steel mills, test benches	Shredders, extruders, materials handling, ...	Customized design, packaging machines, linear drives, ...	Dynamic drives, packaging machines, machine tools, linear drives, ...	Packaging machines, special purpose machines, conveyor technology, ...

● ≈ Standard

TORQUE LIMITERS

TYPES AND OPERATING DESCRIPTION

Product finder of torque limiters

Product	RUFLEX®	KTR-SI	KTR-SI FRE	KTR-SI FRA	SYNTEX®	SYNTEX®-NC	KTR-SI Compact
Type	Torque limiter	Overload system	Overload system	Overload system	Backlash-free overload system		
Types (extract)							
Combined with:							
» Sprocket/toothed belt pulley/flange	●	●	●	●	●	●	●
» ROTEX® torsionally flexible jaw coupling	●	●	●				
» BoWex® torsionally rigid curved-tooth gear coupling®	●						
» TOOLFLEX® torsionally rigid metal bellow-type coupling						●	
» ROTEX® GS backlash-free jaw coupling					●	●	●
» POLY-NORM® torsionally flexible jaw coupling				●			
» RADEX-N® torsionally stiff steel lamina coupling	○	○	○				
» RADEX-NC® torsionally rigid servo lamina coupling						○	
Integrated ball bearing			●			●	●

● ≈ Standard
○ ≈ On request

Information on selection of torque limiters

To make sure that the torque limiter is not released with torque peaks related to the process, the switching torque of the coupling should at least be 30 % above the maximum operating torque (see diagramme).

Torque limiters and overload systems that re-engage automatically should be used with reduced speed only after having applied higher release torques. Frequent or continuous slipping or ratching increases the wear on the torque limiter.

After the torque limiter separated driving from driven side in case of overload, it may take some time until the drive stops due to large inertias in the drive train. This may cause higher wear on the torque limiter and the overload system re-engaging automatically. That is why we recommend to use the overload system KTR-SI as an idle rotating type (page 246 et seqq.) for drives with larger inertias or higher speeds.

We basically recommend electronic monitoring of the torque limiters to disconnect the drive immediately in case of overload.

We will be pleased to assist you with technical questions about the selection of torque limiters.

For that purpose we dispose of state-of-the-art simulation and calculation programs. Here the principle applies: The more detailed the data provided, the more accurate the calculation results.

Unless otherwise specified, our feather keyways are designed acc. to DIN 6885 Bl.1 [JS9]. The shaft-hub-connection needs to be inspected by the customer.

A smooth operation is only ensured if the overload torque set exceeds the maximum operating torque of the machine (see diagramme).

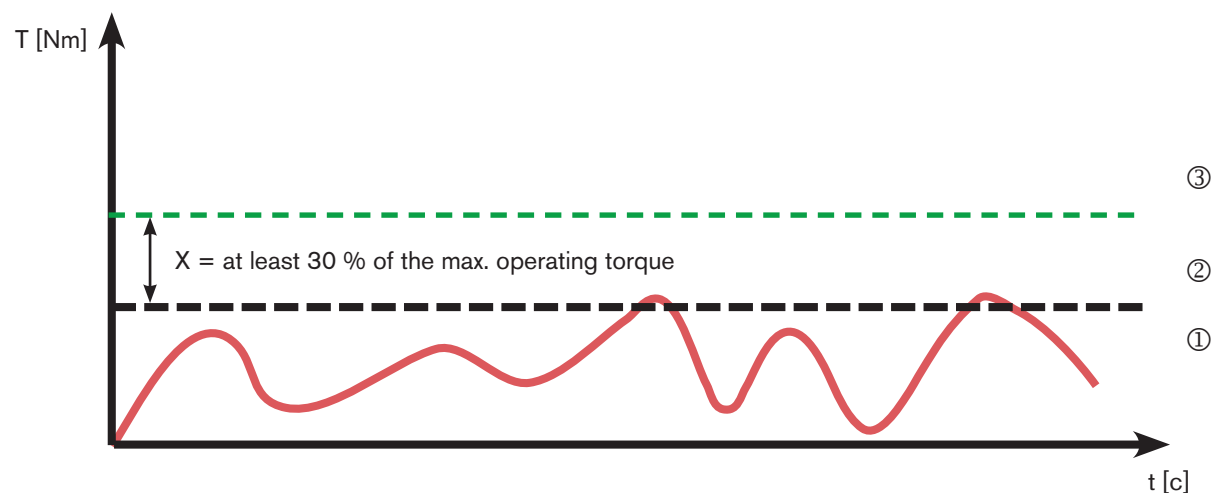

- ① Torque curve of the machine
- ② Max. operating torque arising on the machine
- ③ Torque set on the coupling

RUFLEX®

Torque limiters

Structure and operation

- Load-retaining overload protection up to 12.000 Nm (standard)
- Available with various drive components (e. g. sprocket) and combinations (e.g. ROTEX®)
- Asbestos-free and rust-proof friction lining for dry running (ATEX available on request (Ex))
- High wear capacity, long service life
- High-quality slide bush with dry lubricant
- Torque setting while in place

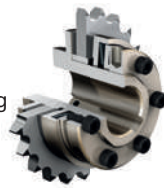

- Securing of the nut by locking in 12 different positions
- Easy assembly and torque setting
- Coupling components made of steel, big safety reserves
- Corrosion protection by zinc-coated and passivated surfaces
- Rust-proof and acid-proof type on request
- High power density due to high-quality disk springs and friction linings

The RUFLEX® modular system provides solutions for your drive, too.

The combination with the approved KTR couplings and the integration of customized drive components (e. g. sprockets) allows for an overload protection optimally adapted to the respective application.

Various disk spring layerings and high-quality friction linings ensure a high power density even with only small mounting space.

RUFLEX® consists of the following components:

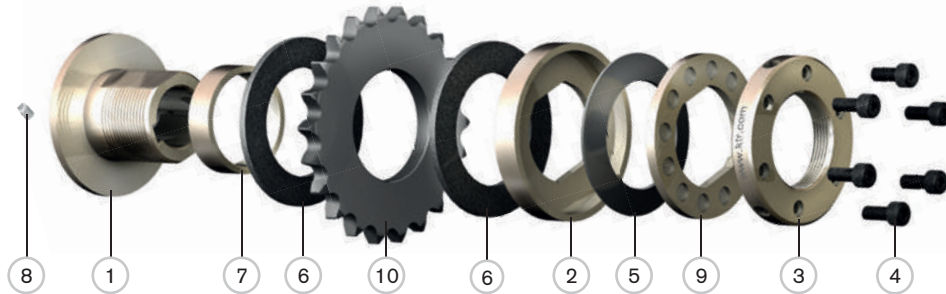

List of components:

- | | |
|-------------------------|------------------------------------|
| ① Hub | ⑥ Friction lining |
| ② Pressure ring | ⑦ Slide bush |
| ③ Setting nut | ⑧ Locking screw |
| ④ Torque setting screws | ⑨ Lock washer |
| ⑤ Disk spring | ⑩ Drive component (e. g. sprocket) |

Disk spring layerings:

- 1TF
- Small specific load on friction linings
 - For small to average torques
 - Long service life of friction linings

- 1TFD
- Small specific load on friction linings
 - Torques like with type 1TF
 - Only small decrease of torque even with a longer period of friction
 - Precision torque adjustment due to double spring excursion

- 2TF
- Average specific load on friction linings
 - Average wear and decrease of torque with longer slipping periods
 - Double torque due to double disk spring layering

- 2TFD
- Average specific load on friction linings
 - Torques like with type 2TF
 - Only small decrease of torque even with a longer period of friction
 - Precision torque adjustment due to double spring excursion

- 3TF
- High specific load on friction linings
 - High wear and decrease of torque with longer slipping periods
 - Suitable only in special cases for designs with only limited dimensions

Standard width of drive component

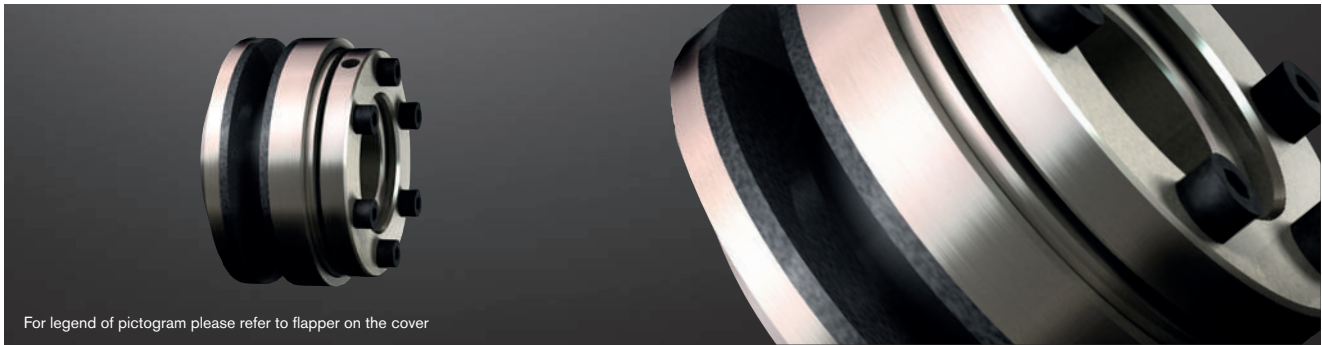

For legend of pictogram please refer to flapper on the cover

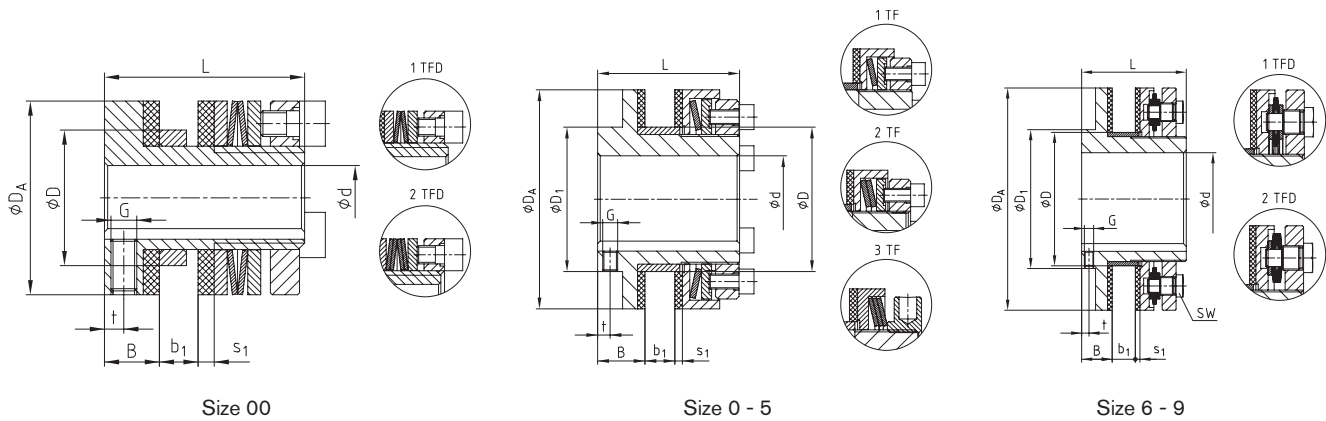

Technical data – dimensions																
Size	Max. speed ⁴⁾ [rpm]	Torques [Nm]			Dimensions [mm]											
					Bore d		Drive component b ₁						Locking screw			
		1TF	2TF	3TF ³⁾	Pilot bore	Max.	D ²⁾	D ₁	D _A	B	Min.	Max.	s ₁	L	t	G
00	10000	(0.5) ⁵⁾ 1-3	2-5	–	–	10	21	–	30	8.5	2	6	2.5	31	3	M4
0	8500	2-10	4-20	–	–	19 (20) ¹⁾	35	45	45	8.5	2	6	2.5	33	3	M4
01	6600	5-35	10-70	–	–	22	40	40	58	16	3	8	3	45	4	M5
1	5600	20-75	40-150	130-200	–	25	44	45	68	17	3	10	3	52	5	M5
2	4300	25-140	50-280	250-400	–	35	58	58	88	19	4	12	3	57	5	M6
3	3300	50-300	100-600	550-800	–	45	72	75	115	21	5	15	4	68	5	M6
4	2700	90-600	180-1200	1100-1600	–	55	85	90	140	23	6	18	4	78	5	M8
5	2200	400-800	800-1600	1400-2100	–	65	98	102	170	29	8	20	5	92	8	M8
6	1900	300-1200	600-2400	–	38	80	116	120	200	31	8	23	5	102	8	M8
7	1600	600-2200	1200-4400	–	45	100	144	150	240	33	8	25	5	113	8	M10
8	1300	900-3400	1800-6800	–	58	120	170	180	285	35	8	25	5	115	8	M10
9	1000	2500-6000	6000-12000	–	65	140	237	225	350	53	16	28	6	162	11	M12

¹⁾ The figure in brackets specifies the max. bore with keyway to DIN 6885 sheet 3 (low-rise design)

²⁾ Bore tolerance (drive component): F8 with size 00 - 4, H8 with size 5 - 9

³⁾ With clamping setting nut to be used on types limited in dimensions only

⁴⁾ See comments on page 245

⁵⁾ With special disk spring

On request:

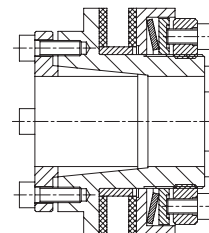
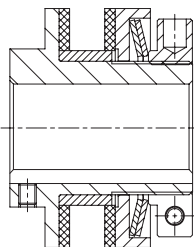

- With clamping setting nut for size 0 - 5 (standard with 3TF)
- For radial torque setting

- With taper bush (hub design 4.5)
- Frictionally engaged shaft-hub-connection

Ordering example:	RUFLEX® 1	2TF	b ₁ 10	d Ø20
	Type/size	Disk spring layering	Width of drive component b ₁	Finish bore

RUFLEX® Torque limiters

With sprocket



For legend of pictogram please refer to flapper on the cover

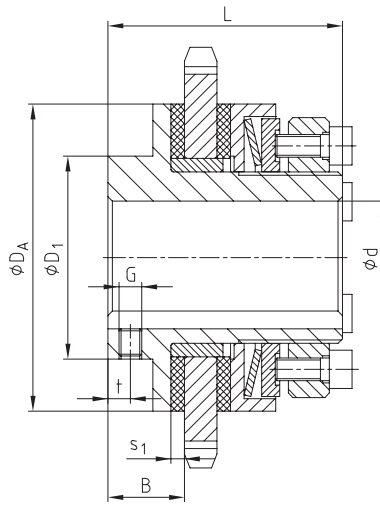

Technical data – dimensions

Size ⁴⁾	Max. speed ³⁾ [rpm]	Torques [Nm]			Dimensions [mm]								
					Max. bore		Locking screw					Standard sprocket ²⁾	
		1TF	2TF	3TF ¹⁾	d	D ₁	D _A	B	s ₁	L	t		G
01	6600	5-35	10-70	–	22	40	58	16	3	45	4	M5	06 B-1 (⁹ / ₈ x ⁷ / ₃₂) z = 23
1	5600	20-75	40-150	130-200	25	45	68	17	3	52	5	M5	08 B-1 (¹ / ₂ x ⁵ / ₁₆) z = 22
2	4300	25-140	50-280	250-400	35	58	88	19	3	57	5	M6	08 B-1 (¹ / ₂ x ⁵ / ₁₆) z = 27
3	3300	50-300	100-600	550-800	45	75	115	21	4	68	5	M6	12 B-1 (³ / ₄ x ⁷ / ₁₆) z = 22
4	2700	90-600	180-1200	1100-1600	55	90	140	23	4	78	5	M8	16 B-1 (1 x 17,02) z = 21

¹⁾ With clamping setting nut to be used on types limited in dimensions only

²⁾ Review minimum number of teeth required / Other sprockets available on request.

³⁾ See comments on page 245

⁴⁾ Other sizes on request

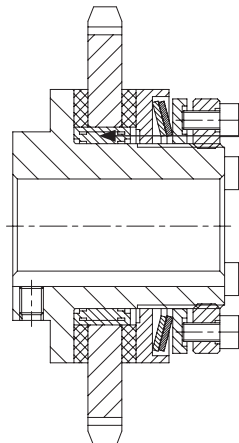

Special type:

- If requested, available with needle bearing instead of slide bush
- For high radial load on the sprocket
- For high speeds or long slipping periods

Ordering example:

RUFLEX® 1	2TF	d Ø20	08 B -1 (¹ / ₂ x ⁵ / ₁₆), z = 29	100 Nm
Type/size	Disk spring layering	Finish bore	Sprocket	Torque set

RUFLEX® Torque limiters

Max. type

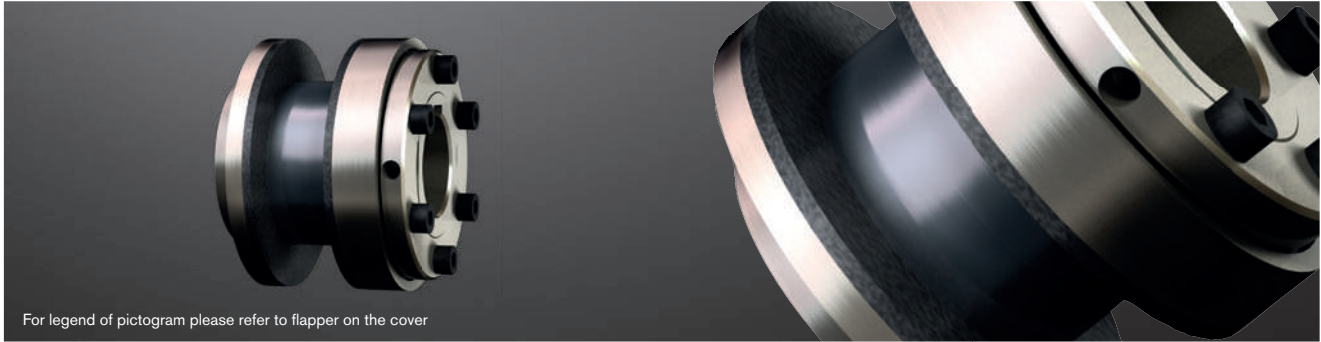

For legend of pictogram please refer to flapper on the cover

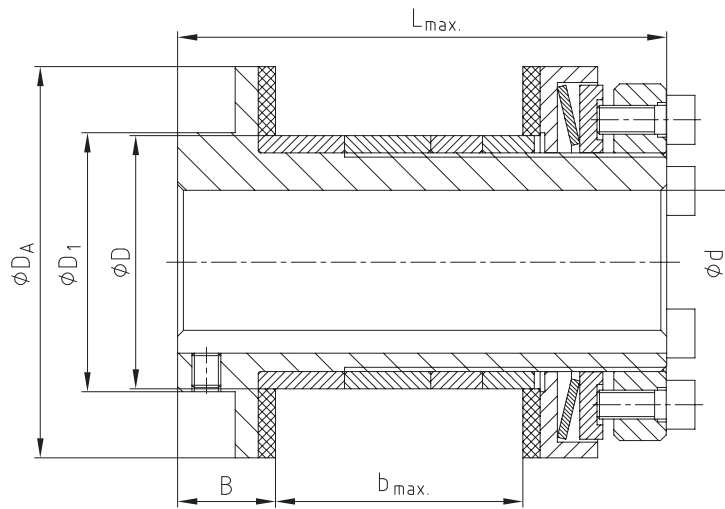

Technical data – dimensions

Size	Max. speed ³⁾ [rpm]	Torques [Nm]			Dimensions [mm]							
		1TF	2TF	3TF ²⁾	Max. bore d	D ₁	D _A	B	Max. b	D ¹⁾	Max. L	
01	6600	5-35	10-70	–	22	40	58	16	33	40	70	
1	5600	20-75	40-150	130-200	25	45	68	17	43	44	85	
2	4300	25-140	50-280	250-400	35	58	88	19	54	58	100	
3	3300	50-300	100-600	550-800	45	75	115	21	62	72	115	
4	2700	90-600	180-1200	1100-1600	55	90	140	23	91.5	85	154	

¹⁾ Bore tolerance (drive component): F8

²⁾ With clamping setting nut to be used on types limited in dimensions only

³⁾ See comments on page 245

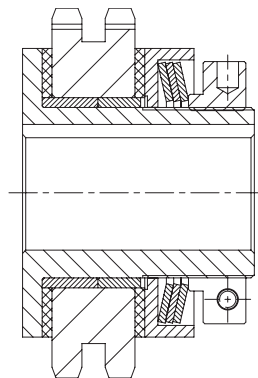

Example:

- RUFLEX® max. with sprocket assembled
- Available as a complete subassembly with torque preset

Ordering example:

RUFLEX® max. 1	2TF	b 35	d Ø20
Type/size	Disk spring layering	Width of drive component b	Finish bore

RUFLEX® Torque limiters

With torsionally flexible ROTEX®



For legend of pictogram please refer to flapper on the cover

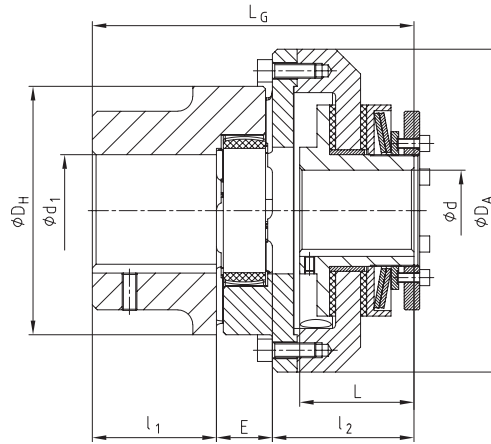

Technical data – dimensions																
RUFLEX® size	ROTEX® size	RUFLEX® Torques [Nm]			ROTEX® ³⁾ Torques [Nm]		Dimensions [mm]									
		1TF	2TF	3TF ²⁾	T _{KN}	T _{K max}	Bore d		Max. bore	D _H	D _A	l ₁	l ₂	E	L	L _G
Pilot bore	Max.	d ₁														
00	14	(0.5) ⁴⁾ 1-3	2-5	-	12.5	25	-	10	16	30	44	11	35	13	31	59.5
0	19	2-10	4-20	-	17	34	-	19 (20) ¹⁾	25	40	63	25	37	16	33	78
01	24	5-35	10-70	-	60	120	-	22	35	55	80	30	50	18	45	98
1	28	20-75	40-150	130-200	160	320	-	25	40	65	98	35	58	20	52	113
2	38	25-140	50-280	250-400	325	650	-	35	48	80	120	45	64	24	57	133
3	48	50-300	100-600	550-800	525	1050	-	45	62	105	162	56	82	28	68	166
4	75	90-600	180-1200	1100-1600	1920	3840	-	55	95	160	185	85	80	40	78	205
5	90	400-800	800-1600	1400-2100	3600	7200	-	65	110	200	260	100	114	45	92	259
6	100	300-1200	600-2400	-	4950	9900	38	80	115	225	285	110	130	50	102	290
7	110	600-2200	1200-4400	-	7200	14400	45	100	125	255	330	120	142	55	113	317
8	140	900-3400	1800-6800	-	12800	25600	58	120	160	320	410	155	152	65	115	372
9	160	2500-6000	6000-12000	-	19200	38400	65	140	185	370	460	175	199	75	161	449

¹⁾ The figure in brackets specifies the max. bore with keyway to DIN 6885 sheet 3 (low-rise design)

²⁾ With clamping setting nut to be used on types limited in dimensions only

³⁾ See selection of ROTEX® couplings on page 14 et seqq.

⁴⁾ With special disk spring

Ordering example:	RUFLEX® 1	2TF	d Ø20	ROTEX® 28	98 ShA	d ₁ Ø25	100 Nm
	Type/size	Disk spring layering	RUFLEX® bore	Type/size	Spider	ROTEX® bore	Torque set

RUFLEX® Torque limiters

With torsionally rigid BoWex®



For legend of pictogram please refer to flapper on the cover

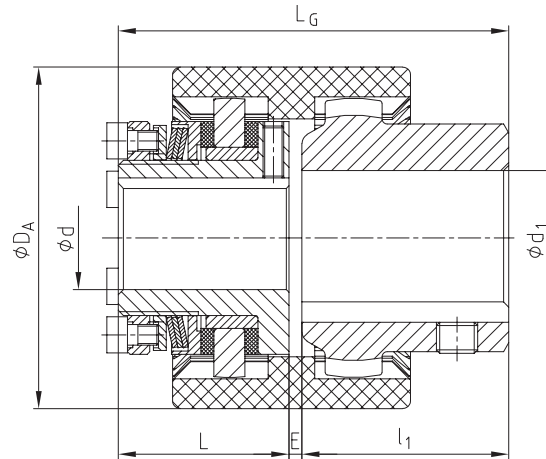

Technical data – dimensions													
RUFLEX® size	BoWex® size	RUFLEX® Torques [Nm]			BoWex® ³⁾ Torques [Nm]		Dimensions [mm]						
		1TF	2TF	3TF ²⁾	TKN	TK max	Max. bore		DA	l ₁	L	E	L _G
00	19	(0.5) ⁴⁾ 1-3	2-5	–	16	32	d	d ₁	48	25.0	31	2.5	58.5
0	28	2-10	4-20	–	45	90	10	19	66	40.0	33	2.5	75.5
01	38	5-35	10-70	–	80	160	19 (20) ¹⁾	28	83	35.5	45	1.0	81.5
1	48	20-75	40-150	130-200	140	280	22	38	95	45.5	52	1.0	98.5
2	65	25-140	50-280	250-400	380	760	25	48	132	64.0	57	1.0	122

¹⁾ The figure in brackets specifies the max. bore with keyway to DIN 6885 sheet 3 (low-rise design)

²⁾ With clamping setting nut to be used on types limited in dimensions only

³⁾ See selection of BoWex® couplings on page 14 et seqq.

⁴⁾ With special disk spring

Ordering example:	RUFLEX® 1	1TF	d Ø20	BoWex® 48	d ₁ Ø25	50 Nm
	Type/size	Disk spring layering	RUFLEX® bore	Type/size	BoWex® bore	Torque set

KTR-SI

Overload systems

Structure and operation

- Overload protection up to 8,200 Nm
- Available as a ratchet, synchronous, idle rotating and fail-safe design having the same dimensions
- Reduction of torque peaks
- High response accuracy, even after a long operating period
- Disconnection of the drive with overload by retrieving limit switch
- Automatically operative (DK, SR, SGR)

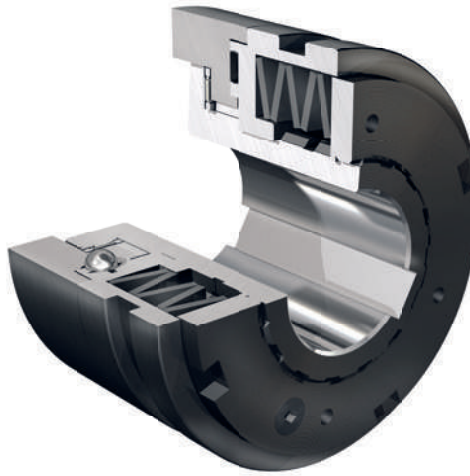

- Available in various designs (e. g. with needle bearing) and combinations (e. g. with torsionally flexible ROTEX®)
- Easy assembly and torque setting
- Maintenance-free
- Insensitive to oil and grease
- Long service life due to high-quality materials

In case of overload the ratchet components (balls or rollers) leave their indentations, and a relative motion between the driving and driven side is generated. Damages caused by overload are reliably prevented in this way. The shift ring (3) makes an axial motion to the engagement travel „H“ activating the limit switch or proximity initiator. The signal can be used for controlling or disconnecting the drive. For restarting we would recommend to bypass the limit switch or proximity switch electrically for a short time.

Component - Description

- | | |
|----|----------------------|
| 1 | Hub |
| 2 | Flange ring |
| 3 | Shifting ring |
| 4 | Setting nut |
| 5 | Disk spring |
| 6 | Ball bearing cage |
| 7 | Slide bush |
| 8 | Axial disk |
| 9 | Axial needle bearing |
| 10 | Setscrew |
| 11 | Lock washer |

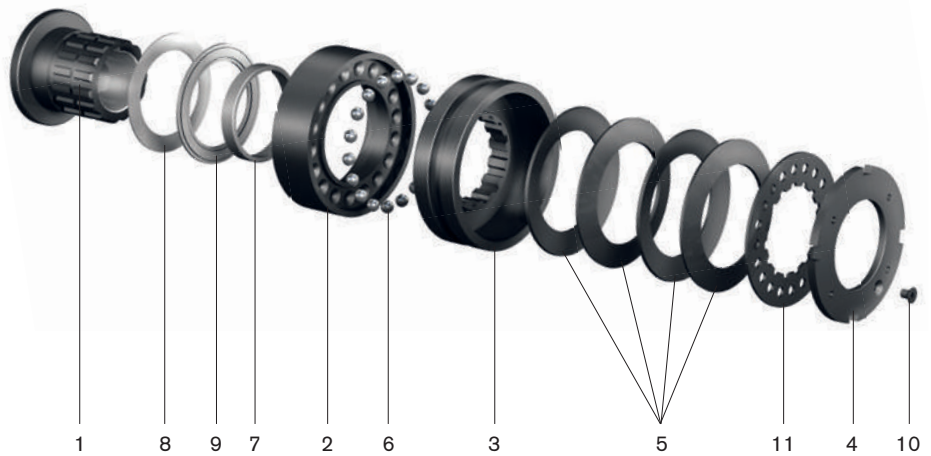

No signal with normal operation

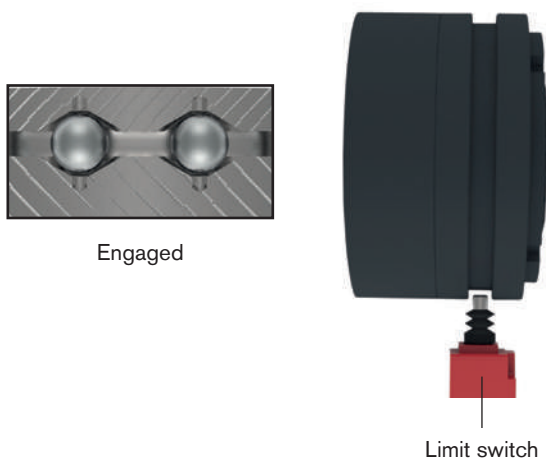

Signal with overload

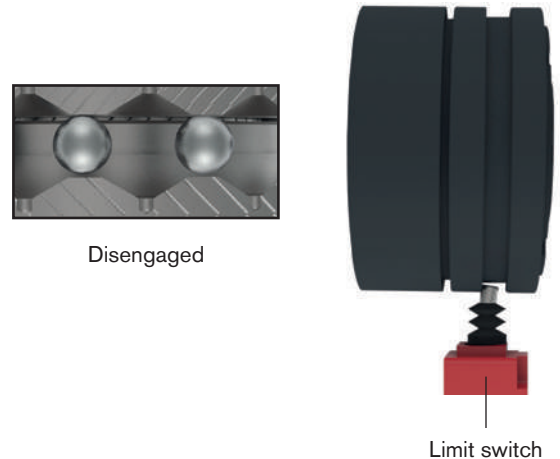

KTR-SI FRE

Idle rotating overload system

Structure and operation

- Setting range up to 60,000 Nm (higher torques available on request)
- Idle rotating overload system (load-separating)
- High repeatability

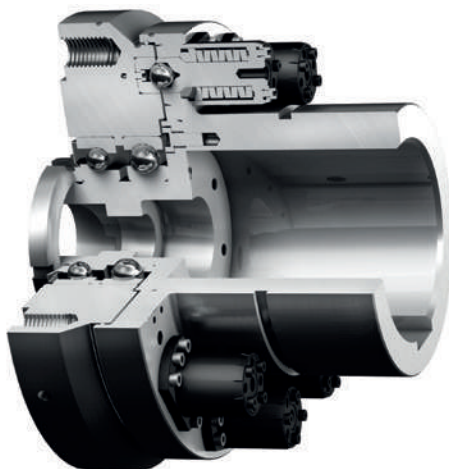

- Flange type to connect toothed belt pulleys or sprockets
- Combination with ROTEX®, GEARex® or RADEX®-N as a shaft-to-shaft connection
- The intelligent further development of shear pin couplings and hydraulic clamping sets

The core of the overload system is formed by the idle rotation elements. They uncouple the driving and driven side in case of overload while protecting the drive train from damages. After eliminating the overload, the rotation segments are manually re-engaged so that the drive is released again. In order to set the coupling to the requested release torque, a defined pre-stress is generated on the disk springs in each idle rotation element via the setting nut. The number of idle rotation elements varies depending on the release torque specified. If requested, the coupling can be preset by the manufacturer. It is also possible to adapt the coupling while in place.

Component - Description

1	Hub
2	Bearing flange
3	Cap screw
4	Angular ball bearing
5	O-ring
6	KTR-SI FRE connection flange
7	Groove ball bearing
8	NILOS ring
9	Supporting disk
10	Safety plate
11	Groove nut
12	Adjusting washer
13	Idle rotation element
14	Locking screw

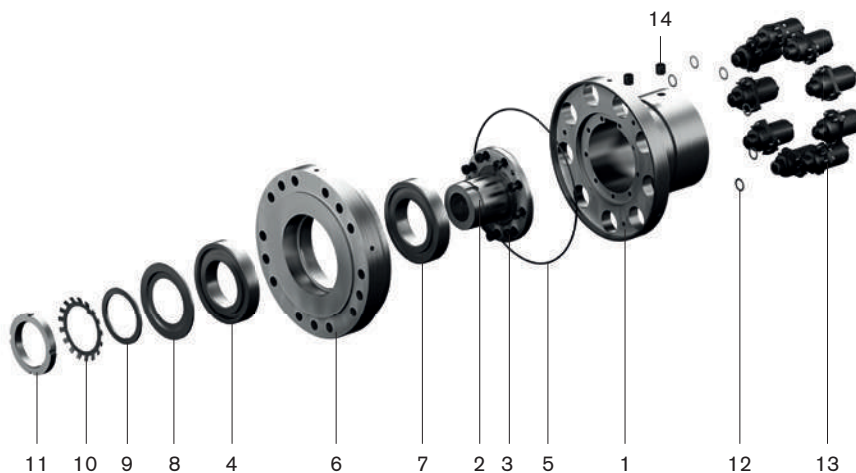

KTR-SI FRA

Idle rotating overload system with automatic re-engagement when reversing the direction of rotation

NEW

Structure and operation

- Overload protection up to 3,000 Nm
- Idle rotating overload system (load-separating)
- Re-engagement by reversing the direction of rotation, thus optimally suitable for positions difficult to access

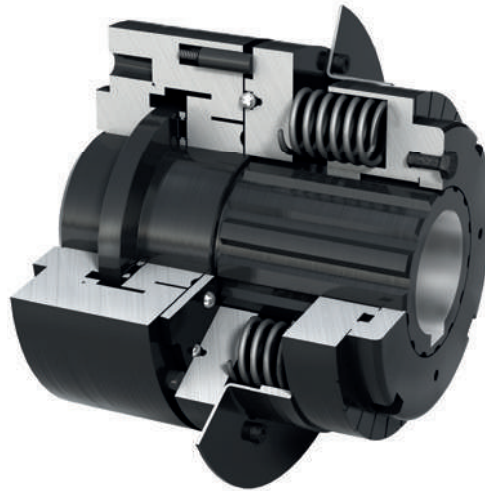

- Flange type to connect toothed belt pulleys or sprockets
- Combination with torsionally flexible POLY-NORM® as a shaft-to-shaft connection

Component - Description

1	Connection flange
2	Slide bearing
3	Axial disk
4	Hub
5	Axial bearing
6	Bearing flange
7	Flange ring
8	Balls
9	Shifting ring
10	Disk springs
11	Pressure ring
12	Lock washer
13	Setting nut



Operating principles

1. Idle rotating design FR/FRE/FRA

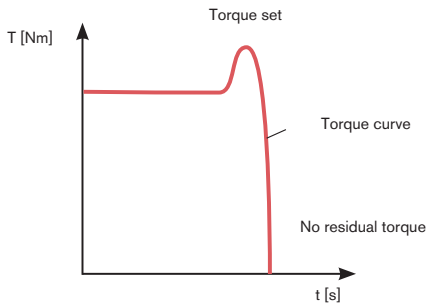

Operating principle of KTR-SI idle rotating couplings:

When achieving the torque set, the coupling rotates. Subject to the idle rotation mechanism driving and driven side remain separated. The resulting flywheel mass can slow down in idle state. After eliminating the overload, the coupling can be re-engaged. The re-engagement is effected manually or via a device respectively automatically.

Re-engagement of FR

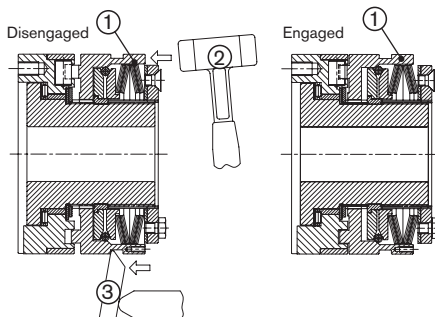

Re-engagement of the idle rotating coupling:

Re-engagement is generated by axial pressure on the shifting ring (1). Dependent on the existing resources, accessibility etc., re-engagement can be effected in different ways: By several blows of a plastic hammer (2) axially on the shifting ring (see above), via assembly levers (3) or a pneumatic or hydraulic engagement device (automated engagement procedure).

Re-engagement of FRE

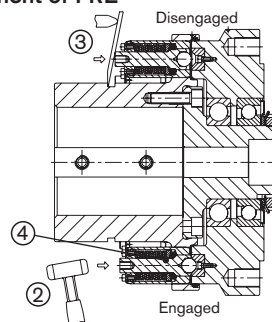

Re-engagement of idle rotating elements:

After eliminating the overload, driving and driven side are aligned to each other. By means of a plastic hammer (2) or a tyre lever (3) the idle rotation elements (4) are manually re-engaged. Re-engagement can be heard loudly. The overload coupling is ready for use again.

Re-engagement of FRA

After eliminating the overload the KTR-SI FRA can be re-engaged by reversing the direction of rotation with slow speed (>100 rpm).

2. Ratchet design DK

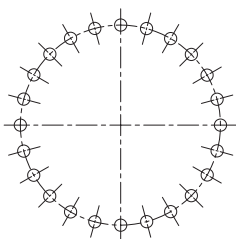

Any engagement after an overload. After eliminating the overload, the balls engage automatically with the next following ball indentation.

3. Synchronous design SR

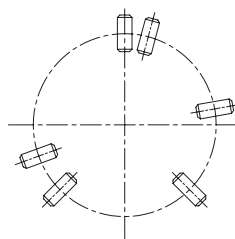

Synchronous engagement after an overload. After eliminating the overload, the balls re-engage automatically with the disk springs after a rotation of 360°. Driving and driven side are always placed in the same position to each other. Other degrees of re-engagement, for example 180°, are also possible.

4. Fail-safe design SGR

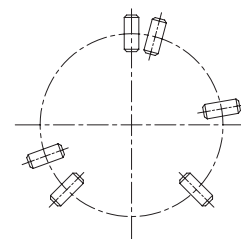

The fail-safe design is purely intended for torque measurement without any ratchet operation. In case of overload a signal is generated by a limit switch along with mechanical separation of driving and driven side = ratching is not possible.

KTR-SI Overload systems

Flange type



For legend of pictogram please refer to flapper on the cover



Type FT

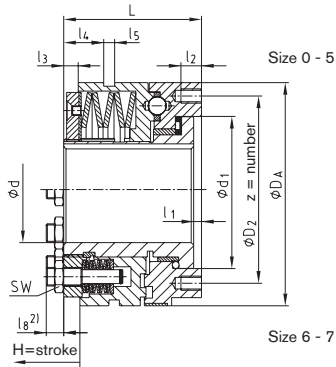

Type KT

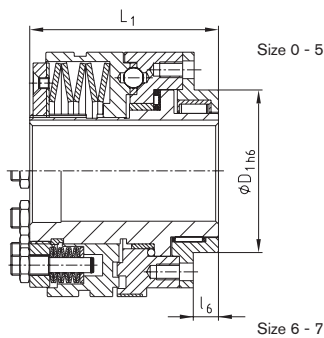

Type LT

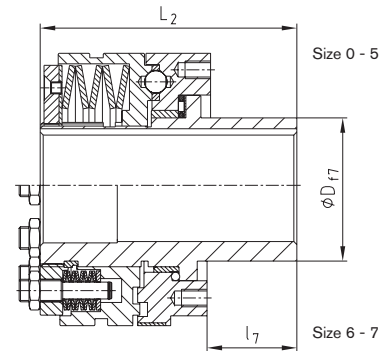

Technical data

Size	Torques [Nm]												Weight with max. bore [kg]
	Type DK				Type SR and SGR				Type FR				
	T1	T2	T3	T4	T1	T2	T3	T4	T1	T2	T3	$n_{max.}^{3)}$ [rpm]	
0	2.5-5	5-20	–	20-40	5-10	10-40	–	–	5-10	10-20	20-40	6000	0.41
1	6-12	12-25	25-55	55-100	12-25	25-50	50-100	–	12-25	25-50	50-100	5000	1.30
2	12-25	25-50	50-120	120-200	25-50	50-100	100-200	–	25-50	50-100	100-200	4000	2.27
3	25-50	50-100	100-250	200-450	50-100	100-200	200-450	–	50-100	100-200	200-450	3500	3.88
4	50-100	100-200	200-500	500-1000	100-200	200-400	400-800	800-2000	100-200	200-400	400-800	3000	8.34
5	85-250	230-600	300-1000	600-2000	170-450	350-900	600-1800	1200-3400	170-450	350-900	600-1800	2300	13.51
6	180-480	360-960	720-1950	1600-3300	300-750	600-1500	1200-3000	2900-5800	–	–	–	–	21
7	250-520	500-1050	1000-2100	2000-3600	550-1100	1100-2200	2200-4400	3000-8200	–	–	–	–	37

Dimensions [mm]

Size	Bore d		d ₁	D	D ₁	D ₂	D _A	l ₁	l ₂	l ₃	l ₄	l ₅	l ₆	l ₇	L	L ₁	L ₂	z	H=stroke			
	Pilot bore	Max.																	DK	SR	SGR	FR
0	7	20	41.0	28	38	48	55	4.0	6.5	3.0	7.5	9	8	27.5	38.5	51.0	66.0	6xM5	1.4	1.2	0.6	1.6
1	10	25	60.0	38	50	70	82	4.0	8.0	6.0	11.5	9	10	33.0	52.0	70.0	85.0	6xM5	2.3	1.8	0.8	2.3
2	14	35	78.0	52	60	89	100	5.0	10.0	5.0	12.0	9	12	39.0	61.0	78.0	100.0	6xM6	2.4	2.0	1.1	3.0
3	18	45	90.5	65	80	105	120	5.0	12.0	8.5	21.0	10	12	47.0	78.0	96.0	125.0	6xM8	2.7	2.2	1.2	3.5
4	24	55	105.0	78	100	125	146	6.5	15.0	11.0	27.0	9	16	52.5	100.0	124.5	152.5	6xM10 ¹⁾	3.7	2.5	1.2	3.8
5	30	65 (70) ⁴⁾	120.5	90	120	155	176	6.5	17.0	12.0	33.0	9	18	57.5	113.5	140.0	171.0	6xM12 ¹⁾	4.6	3.0	1.6	4.5
6 ²⁾	40	80	136.0	108	130	160	200	7.0	20.0	14.0	39.0	9	20	64.0	119.0	150.0	183.0	6xM12 ¹⁾	5.0	3.5	2.5	–
7 ²⁾	50	100 (110) ⁴⁾	168.0	135	160	200	240	8.0	25.0	15.0	46.0	9	25	72.0	141.0	175.0	213.0	6xM16 ¹⁾	5.5	4.0	2.7	–

¹⁾ Type T4 SR and SGR: tightening torques according to 12.9

²⁾ Size 6: dimension l₈ = 15 mm, size 7: dimension l₈ = 21 mm

³⁾ See comments on page 245

⁴⁾ The figure in brackets specifies the max. bore with keyway to DIN 6885 sheet 3 (low-rise design)

Ordering
example:

KTR-SI 2	FR	FT	T2	d Ø20	40 Nm
Type/size	Type (DK/SR/SGR/FR)	Type	Disk spring layering	Bore	Torque set

KTR-SI Overload systems

With torsionally flexible ROTEX®



For legend of pictogram please refer to flapper on the cover

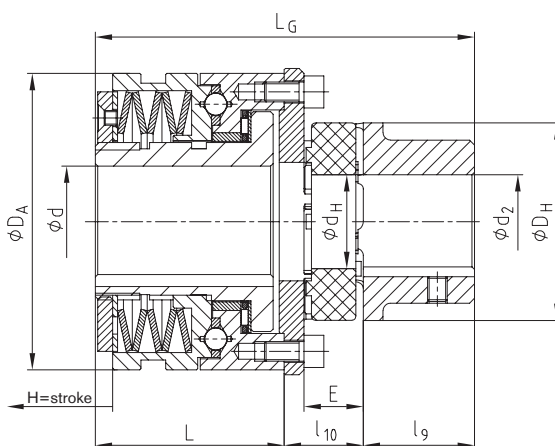

Technical data

KTR-SI size	Torques [Nm]										
	Type DK				Type SR and SGR				Type FR		
	T1	T2	T3	T4	T1	T2	T3	T4	T1	T2	T3
0	2.5-5	5-20	–	20-40	5-10	10-40	–	–	5-10	10-20	20-40
1	6-12	12-25	25-55	55-100	12-25	25-50	50-100	–	12-25	25-50	50-100
2	12-25	25-50	50-120	120-200	25-50	50-100	100-200	–	25-50	50-100	100-200
3	25-50	50-100	100-250	200-450	50-100	100-200	200-450	–	50-100	100-200	200-450
4	50-100	100-200	200-500	500-1000	100-200	200-400	400-800	800-2000	100-200	200-400	400-800
5	85-250	230-600	300-1000	600-2000	170-450	350-900	600-1800	1200-3400	170-450	350-900	600-1800
6	180-480	360-960	720-1950	1600-3300	300-750	600-1500	1200-3000	2900-5800	–	–	–
7	250-520	500-1050	1000-2100	2000-3600	550-1100	1100-2200	2200-4400	3000-8200	–	–	–

Technical data – dimensions

KTR-SI size	ROTEX® size	ROTEX® ¹⁾ Torque [Nm]		Max. bore		Dimensions [mm]								H=stroke		
		98 ShA		d	d2	dH	DH	DA	l9	l10	E	L	LG	Type		
		TKN	TK max											DK	SR	FR
0	19	17	34	20	25	18	40	55	25	22	16	38.5	85.5	1.4	1.2	1.6
	28	160	320		40	30	65		35	28.5	20		102			
1	24	60	120	25	35	27	55	82	30	24	18	52	106	2.3	1.8	2.3
	38	325	650		48	38	80		45	32.5	24		129.5			
2	28	160	320	35	40	30	65	100	35	28	20	61	124	2.4	2.0	3.0
	48	525	1050		62	51	105		56	38	28		155			
3	38	325	650	45	48	38	80	120	45	32	24	78	155	2.7	2.2	3.5
	55	685	1370		74	60	120		65	43	30		186			
4	48	525	1050	55	62	51	105	146	56	38	28	100	194	3.7	2.5	3.8
	75	1920	3840		95	80	160		85	56.5	40		241.5			
5	55	685	1370	65 (70) ²⁾	70	60	120	176	65	44	30	113.5	222.5	4.6	3.0	4.5
	90	3600	7200		110	100	200		100	62	45		275.5			
6	100	4950	9900	80	115	113	225	200	110	72	50	119	301	5.0	3.5	–
7	110	7200	14400	100 (110) ²⁾	125	127	255	240	120	78	55	141	339	5.5	4.0	–

¹⁾ See selection of ROTEX® couplings on page 14 et seqq.

²⁾ The figure in brackets specifies the max. bore with keyway to DIN 6885 sheet 3 (low-rise design)

Ordering example:

KTR-SI 2	DK	T2	d Ø20	ROTEX® 28	98 ShA	d2 Ø25	40 Nm
Type/size	Type (DK/SR/SGR/FR)	Disk spring layering	KTR-SI bore	Type/size	Spider	ROTEX® bore	Torque set

KTR-SI FRE

Idle rotating overload system

Flange type

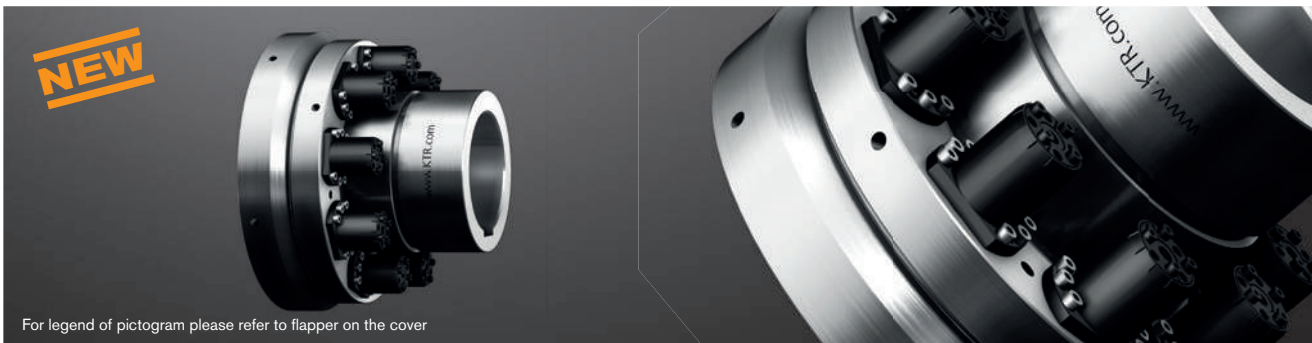

For legend of pictogram please refer to flapper on the cover

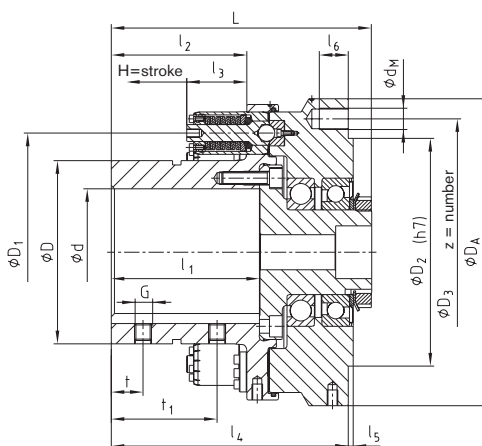

Torques [Nm]							
Size	Type of element	3 idle rotation elements		6 idle rotation elements		9 idle rotation elements	
		Min.	Max.	Min.	Max.	Min.	Max.
9	1T2	1000	4000	2000	8000	-	-
	1T3	2400	5500	4800	11000	-	-
12	1T2	1300	5000	2600	10000	3900	15000
	1T3	2900	6700	5800	13400	8700	20100
15	1T2	1700	6000	3400	12000	5100	18000
	1T3	3500	8200	7000	16400	10500	24600
20	2T2	5000	15000	10000	30000	15000	45000
	2T3	13100	20000	26300	40000	39400	60000

Technical data – dimensions																								
Size ¹⁾	Max. bore	Dimensions [mm]																			Max. permissible forces on the flange connection ²⁾ [kN]		Speed ³⁾ [rpm]	Weight with max. bore [kg]
		d	D	D1	D2	D3	DA	l1	l2	l3	l4	l5	l6	G	t	t1	L	dM	z	Pitch	H=stroke	Radial		
9	90	135	185	200	225	260	120	110	56.7	197	2.5	17.5	M12	25	75	213.5	12	12	12x30°	5.2	18	13	3300	38
12	120	173	225	215	252	290	140	128	56.7	224	4.5	27.5	M16	30	100	246	20	15	20x18°	5.2	26	18	2300	57
15	150	215	270	245	282	324	170	160	56.7	258	4.5	27.5	M20	40	120	281	20	15	20x18°	5.2	30	20	2050	81
20	200	285	370	330	375	460	220	200	88.4	341	5	33.0	M20	50	150	366	24	18	24x15°	8.9	50	40	1550	211

¹⁾ Other sizes on request

²⁾ Larger forces on request

³⁾ Higher speeds on request, see comments on page 245



Special type:

- KTR-SI FRE with sprocket
- Available as a complete subassembly with torque preset

Ordering example:	KTR-SI FRE 12	1T2	9	d Ø85	7500 Nm
	Type/size	Type of element	Number of idle rotating elements	KTR-SI FRE bore	Torque set

KTR-SI FRE

Idle rotating overload system

With torsionally flexible ROTEX®

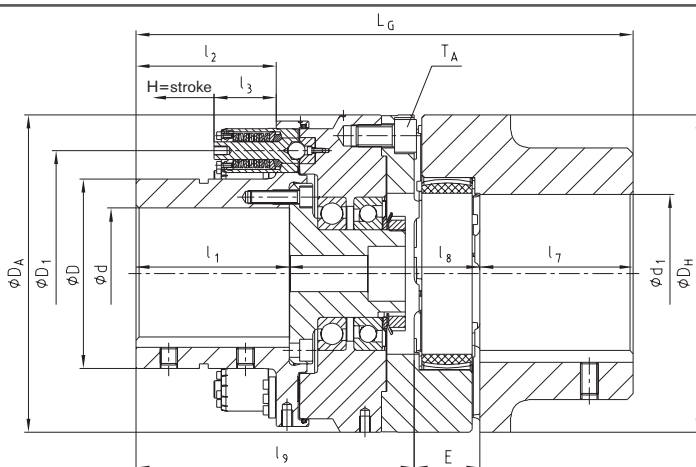

Torques [Nm]							
Size	Type of element	3 idle rotation elements		6 idle rotation elements		9 idle rotation elements	
		Min.	Max.	Min.	Max.	Min.	Max.
9	1T2	1000	4000	2000	8000	-	-
	1T3	2400	5500	4800	11000	-	-
12	1T2	1300	5000	2600	10000	3900	15000
	1T3	2900	6700	5800	13400	8700	20100
15	1T2	1700	6000	3400	12000	5100	18000
	1T3	3500	8200	7000	16400	10500	24600
20	2T2	5000	15000	10000	30000	15000	45000
	2T3	13100	20000	26300	40000	39400	60000

Technical data – dimensions																							
Size ¹⁾	ROTEX®			Max. bore		Dimensions [mm]															TA [Nm]	Speed ²⁾ [rpm]	Weight with max. bore [kg]
	Size	Torque ³⁾ [Nm]		d	d1	D	D1	DH	DA	l1	l2	l3	l7	l8	l9	E	LG	H=stroke					
		TKN	TK max																				
9	90	4500	9000	90	110	135	185	200	260	120	110	56.7	100	133	217	45	362	5.2	117	3300	59		
12	125	12500	25000	120	145	173	225	290	290	146	130	56.7	140	165	254	60	454	5.2	560	2300	106		
15	140	16000	32000	150	160	215	270	320	324	170	160	56.7	155	176	292	65	512	5.2	560	2050	147		
20	180	35000	70000	200	200	285	370	420	460	220	200	88.4	195	227	381	85	661	8.9	970	1550	349		

¹⁾ Other sizes on request

²⁾ Higher speeds on request, see comments on page 245

³⁾ See selection of ROTEX® couplings on page 14 et seq.



Special type:

- KTR-SI FRE with torsionally flexible pin & bush coupling REVOLEX® KX-D and limitation of axial backlash
- KTR-SI FRE with torsionally rigid all-steel gear coupling GEARex® and integrated brake disk
- KTR-SI FRE with torsionally rigid lamina coupling RADEX®-N and integrated brake disk

Ordering example:

KTR-SI FRE 12	1T3	9	d Ø85	ROTEX® 125	98 ShA	d1 Ø85	12000 Nm
Type/size	Type of element	Number of idle rotation elements	KTR-SI FRE bore	Type/size	Spider	ROTEX® bore	Torque set

KTR-SI FRA

Idle rotating overload system with automatic re-engagement when reversing the direction of rotation

Flange type FT

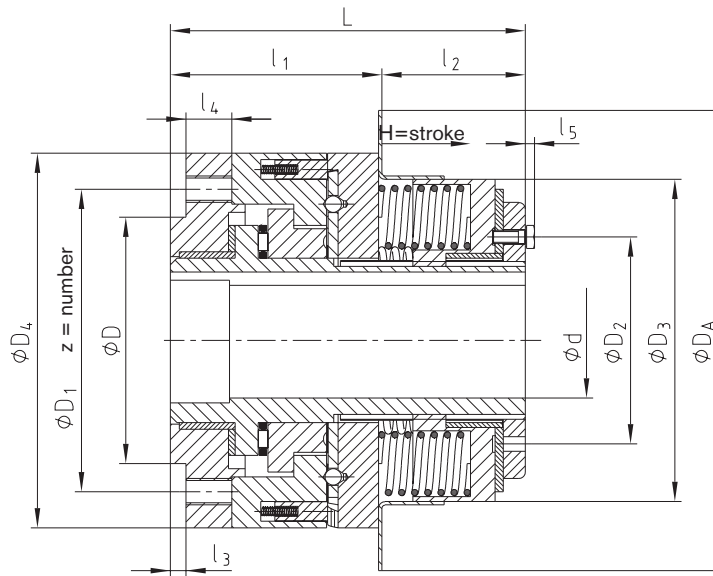

Torques [Nm]				
Size	T1	T2	T3	T4
2	5-20	15-70	40-135	80-260
3	24-104	57-360	110-540	245-730
4	45-210	145-435	340-960	465-1320
5	90-415	240-640	490-1880	1060-3000

Technical data – dimensions																	
Size	Max. bore d	Dimensions [mm]														Speed ¹⁾ [rpm]	Weight with max. bore [kg]
		D _{j7}	D ₁	D ₂	D ₃	D ₄	D _A	l ₁	l ₂	l ₃	l ₄	l ₅	L	z	H=stroke		
2	35	75	92	70	98	114	140	63	45	4.7	14	-	108	6xM8	2.8	3600	5
3	45	95	114	77	131	149	184	69	42	4.7	15	3.5	111	7xM10	3.5	3600	10
4	55	122	144	88	147	166	203	75	46	4.7	15	4.0	121	8xM12	3.5	2000	13
5	80	155	184	152	196	223	279	94	70	6.3	23	2.3	164	8xM16	4.4	2000	32

¹⁾ See comments on page 245

Ordering example:	KTR-SI FRA 3	FT	T3	d Ø35	300 Nm
	Type/size	Type	Torque setting range	KTR-SI FRE bore	Torque set

KTR-SI FRA

Idle rotating overload system with automatic re-engagement when reversing the direction of rotation

With torsionally flexible POLY-NORM®

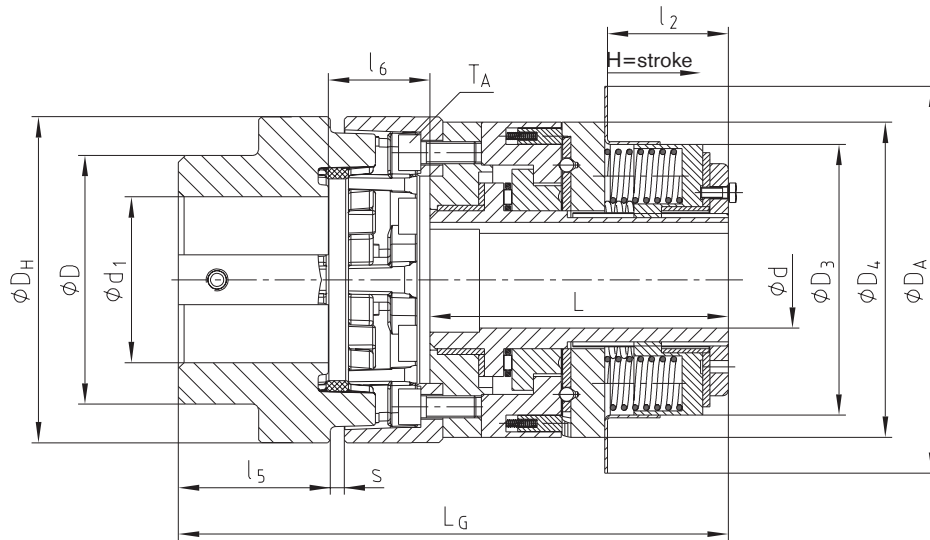

Torques [Nm]

KTR-SI FRA size	T1	T2	T3	T4
2	5-20	15-70	40-135	80-260
3	24-104	57-360	110-540	245-730
4	45-210	145-435	340-960	465-1320
5	90-415	240-640	490-1880	1060-3000

Technical data – dimensions

KTR-SI FRA size	POLY-NORM®			Max. bore		Dimensions [mm]													TA [Nm]	Speed ¹⁾ [rpm]	Weight with max. bore [kg]
	Size	Torque [Nm]		d	d1	D	D3	D4	DH	DA	l1	l2	l5	l6	s	LG	L	H=stroke			
2	55	300	600	35	60	90	98	114	118	140	108	45	55	27	5	189.3	108	2.8	23	3600	9
3	75	850	1700	45	70	123	131	149	158	184	111	42	75	33.8	5	218.8	111	3.5	46	3600	18
4	85	1350	2700	55	80	139	147	166	182	203	121	46	85	52.6	5	257.6	121	3.5	79	2000	25
5	100	3900	7800	80	90	165	196	223	224	279	164	70	100	63.2	6	326.2	164	4.4	195	2000	51

¹⁾ See comments on page 245

Ordering example:

KTR-SI FRA 3	T3	d Ø35	POLY-NORM® 75	AR	d1 Ø45	300 Nm
Type/size	Torque setting range	KTR-SI FRA bore	Type/size	Type	POLY-NORM® bore	Torque set

SYNTEX®

Backlash-free overload systems

Structure and operation

- Backlash-free, torsionally rigid overload protection up to 400 Nm, suitable for reversing operation
- Disconnection of the drive in case of overload
- Reduction of torque peaks
- High response accuracy, even after a long operating period
- Easy integration of customer components
- Compact design, low mass moment of inertia
- Variable due to modular system
- Special disk springs available for special applications

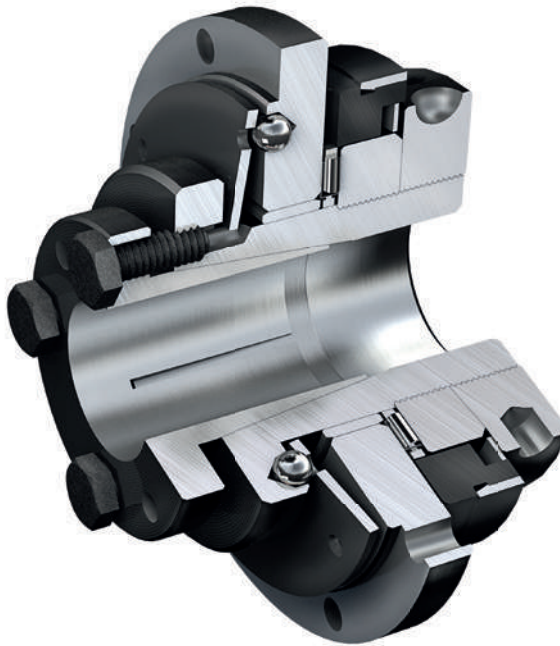

- Low-cost protection even for simple drives
- Easy assembly and torque setting
- Maintenance-free
- Insensitive to oil and grease
- Long service life due to small internal loads
- Backlash-free shaft-hub-connections
- Any or synchronous re-engagement
- Automatically operative

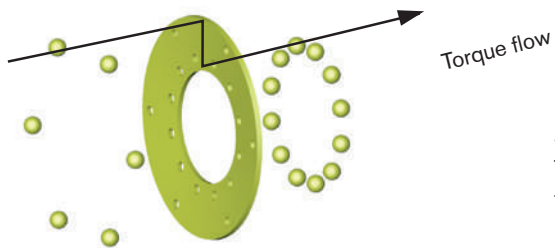

SYNTEX® is an overload system with positive locking operation. The punched disk spring is a component serving for transmitting the torque.

SYNTEX®
Overload system with mounting flange



SYNTEX®
Overload system with sprocket



SYNTEX®
Overload system with ROTEX® GS

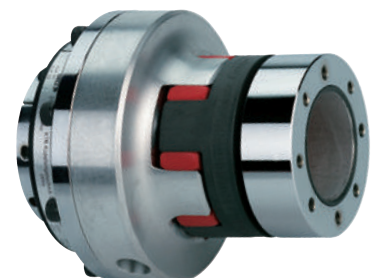

Operating principles

Ratchet design DK

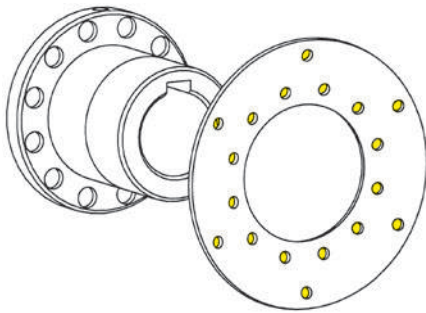

Synchronous design SK

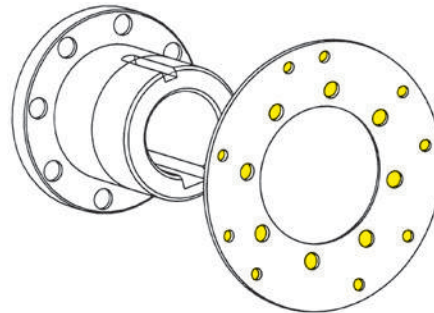

If the torque set is exceeded, a relative movement is generated between the driving and driven side. The transmittable torque is reduced to a minimum.

The balls leave the indentations of the disk springs. After eliminating the overload, the balls engage automatically with the next following ball indentation of the disk springs.

If the torque set is exceeded, a relative movement is generated between the driving and driven side. The transmittable torque is reduced to a minimum.

The balls leave the indentations of the disk springs. After eliminating the overload, the balls re-engage automatically with the disk springs after a rotation of 360° subject to their special pitch. Driving and driven side are always placed in the same position to each other (other degrees of re-engagement, for example 180°, are also possible).

Signal by limit switch or sensor in case of overload

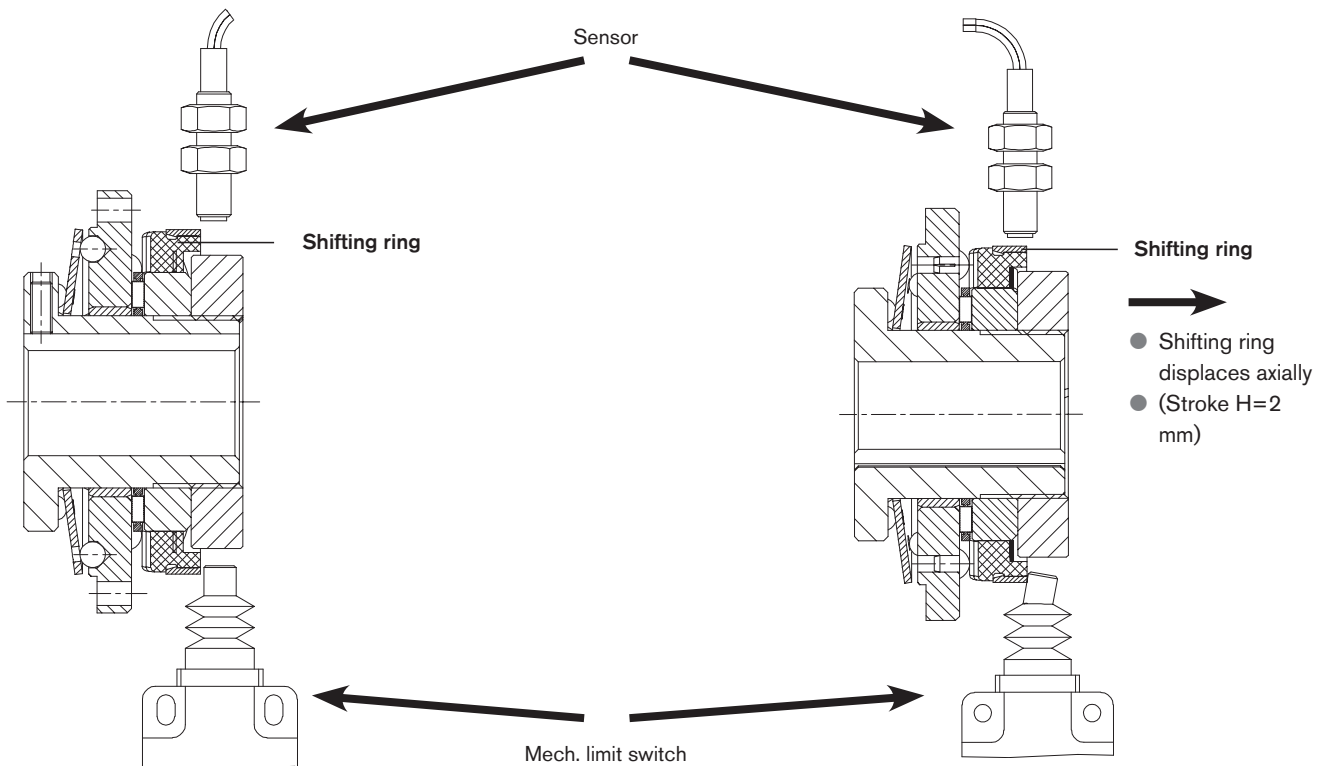

Normal operation:
No signal by sensor or mechanical limit switch.

In case of overload:
The axial motion of the shifting ring activates the sensor or mechanical limit switch, respectively. The resulting signal can be used for control operation (e. g. motor stop).

SYNTEX®

Backlash-free overload systems

Flange type



For legend of pictogram please refer to flapper on the cover



Technical data – dimensions

Size	Torques [Nm]				Max. speed ¹⁾ [rpm]	Dimensions [mm]															
	Ratchet design DK		Synchronous design SK			Max. bore	D	D ₁	D ₂	D ₃	D ₄	D _A	l ₁	l ₂	l ₃	l ₄	l ₅	d ₁	L	z	H=stroke
	DK ₁	DK ₂	SK ₁	SK ₂																	
20	6-20	15-30	10-20	20-65	1500	20	48	54	61.5	65	71	80	8	2	16	6	35	4.5	45	8	2
25	20-60	45-90	25-65	40-100	1500	25	60	68	80	81	89	98	8	2	17	8	39	5.5	50	8	2
35	25-80	75-150	30-100	70-180	1000	35	75	78	91	102	110	120	10	2	21	10	42	5.5	60	12	2
50	60-180	175-300	80-280	160-400	1000	50	105	108	121	142	152	162	12	2	25	13	56	6.6	70	12	2

Dimensions – Hub design 4.5

Size	Dimensions [mm]							Clamping screws	Tightening torque T _A [Nm]
	d ₁ max.	l ₆	l ₇	l ₈	L ₁	s			
20	20	9	3.5	23	54	3	4 x M5	8.5	
25	25	11	4.0	28	61	4	4 x M6	14	
35	35	10	4.0	31	70	4	4 x M6	14	
50	50	12	4.0	37	82	6	4 x M6	14	

Transmittable friction torques T_R [Nm] (fitting tolerance H7/h6) of hub design 4.5

Size	Ø12	Ø14	Ø15	Ø16	Ø17	Ø18	Ø19	Ø20	Ø22	Ø23	Ø24	Ø25	Ø28	Ø30	Ø32	Ø35	Ø38	Ø40	Ø42	Ø45	Ø48	Ø50
20	45	62	71	81	92	103	115	127														
25		72	83	95	107	120	133	148	179	196	213	231										
35									127	139	152	165	207	237	270	323						
50																238	281	311	343	394	448	486

¹⁾ See comments on page 245

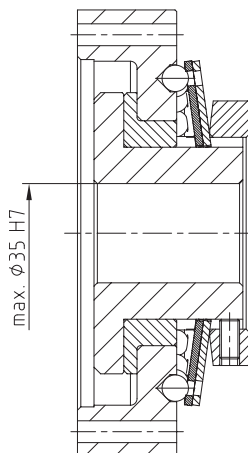

Special type:

- SYNTEX 35 spec. with integrated flange
- Performance range up to 360 Nm
- Adjustment of flange to ambient components possible

Ordering example:

SYNTEX® 25	d Ø20	DK1	1.0	45 Nm
Type/size	Bore	Type (DK/SK)	Hub design	Torque set

Hub design 1.0

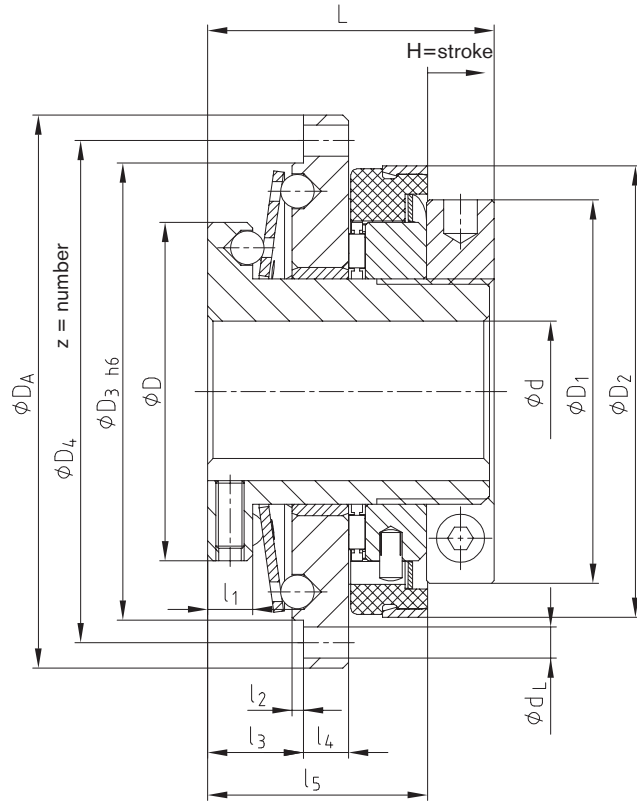

Hub design 4.5

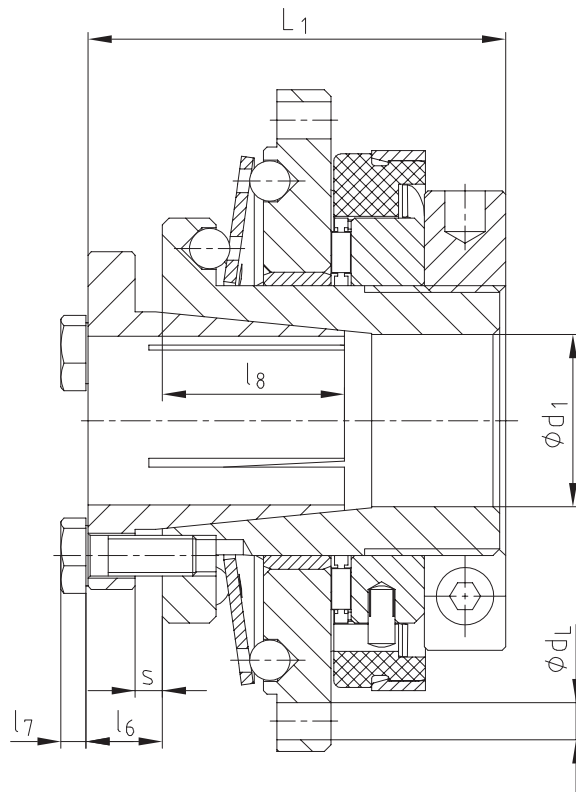

SYNTEX®

Backlash-free overload systems

With sprocket



For legend of pictogram please refer to flapper on the cover



Technical data – dimensions

Size	Torque [Nm]				Max. speed ²⁾ [rpm]	Dimensions [mm]													
	Ratchet design DK		Synchronous design SK			Max. bore d	Standard sprocket ¹⁾					D	D ₁	D ₂	l ₁	l ₃	l ₅	L	H=stroke
	DK1	DK2	SK1	SK2															
20	6-20	15-30	10-20	20-65	1500	20	06 B-1 (⁹ / ₈ x ⁷ / ₃₂) z = 25					48	54	61.5	8	14	33	45	2
25	20-60	45-90	25-65	40-100	1500	25	08 B-1 (¹ / ₂ x ⁵ / ₁₆) z = 24					60	68	80	8	15	37	50	2
35	25-80	75-150	30-100	70-180	1000	35	08 B-1 (¹ / ₂ x ⁵ / ₁₆) z = 29					75	78	91	10	19	41	60	2
50	60-180	175-300	80-280	160-400	1000	50	12 B-1 (³ / ₄ x ⁷ / ₁₆) z = 27					105	108	121	12	23	52	70	2

Dimensions – Hub design 4.5

Size	Dimensions [mm]							Tightening torque T _A [Nm]
	d ₁ max.	l ₆	l ₇	l ₈	L ₁	s	Clamping screws	
20	20	9	3.5	23	54	3	4 x M5	8.5
25	25	11	4.0	28	61	4	4 x M6	14
35	35	10	4.0	31	70	4	4 x M6	14
50	50	12	4.0	37	82	6	4 x M6	14

Transmittable friction torques T_R [Nm] (fitting tolerance H7/h6) of hub design 4.5

Size	Ø12	Ø14	Ø15	Ø16	Ø17	Ø18	Ø19	Ø20	Ø22	Ø23	Ø24	Ø25	Ø28	Ø30	Ø32	Ø35	Ø38	Ø40	Ø42	Ø45	Ø48	Ø50
20	45	62	71	81	92	103	115	127														
25		72	83	95	107	120	133	148	179	196	213	231										
35									127	139	152	165	207	237	270	323						
50																238	281	311	343	394	448	486

¹⁾ z = min. number of teeth required / Other sprockets available on request

²⁾ See comments on page 245

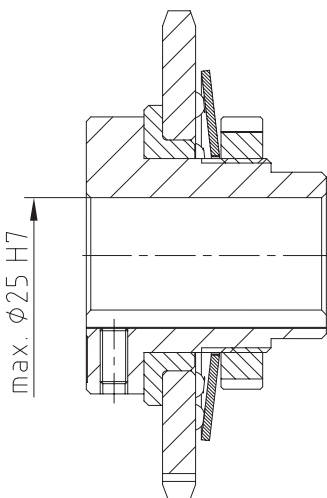

Special type:

- Standard SYNTEX® with integrated belt drive or sprocket
- Available ready for assembly with the torque set
- Reduction of components by integration of components
- Available both as a ratchet and synchronous design
- Torque setting possible while in place
- Finish bore according to ISO fit H7, feather keyway according to DIN 6885, sheet 1 [JS9]
- Also available with a frictionally engaged shaft-hub-connection (hub design 4.5)

Ordering example:

SYNTEX® 25	DK1	1.0	d Ø20	08 B-1 (¹ / ₂ x ⁵ / ₁₆), z = 29	45 Nm
Type/size	Type (DK/SK)	Hub design	Bore	Sprocket	Torque set

Hub design 1.0

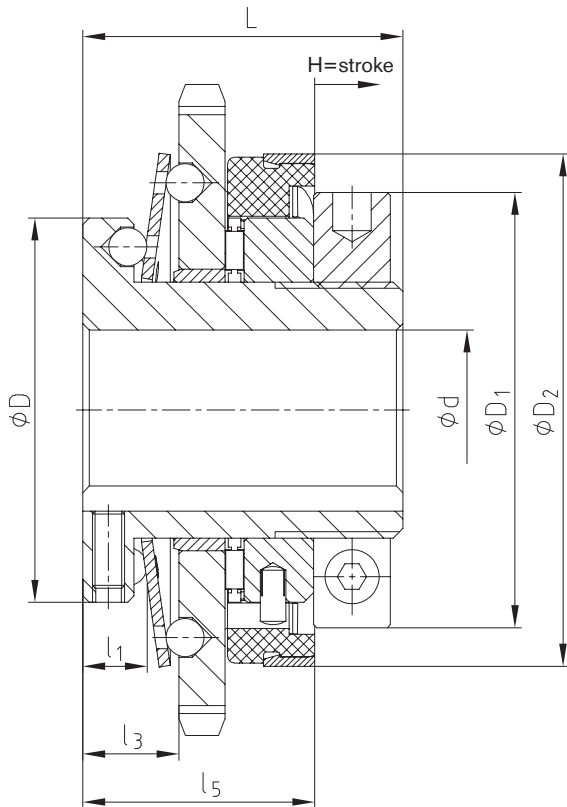

KTR-SI

SYNTEX®

Hub design 4.5

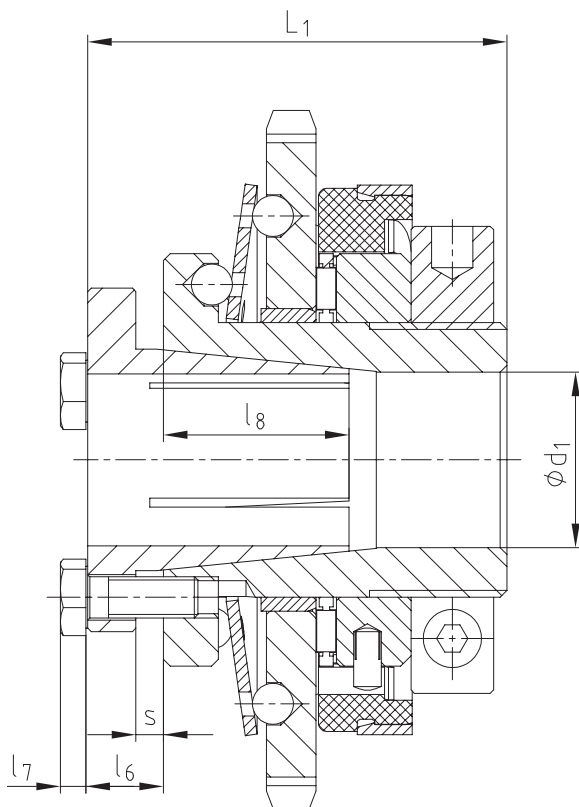

SYNTEX®-NC

Torque limiters

KTR-SI Compact

SYNTEX®

Backlash-free overload systems

With toothed belt pulley



For legend of pictogram please refer to flapper on the cover



Hub design 1.0

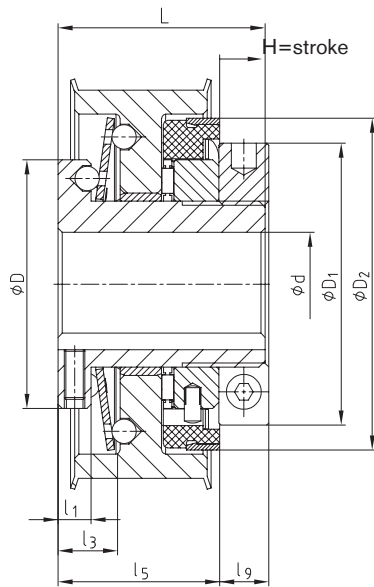

Hub design 4.5

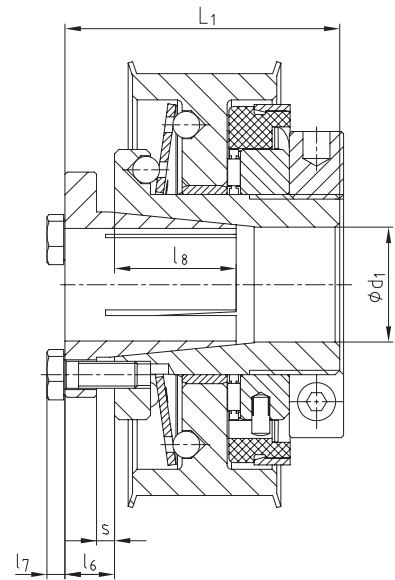

Technical data – dimensions

Size	Torques [Nm]				Max. speed ²⁾ [rpm]	Dimensions [mm]										
	Ratchet design DK		Synchronous design SK			Max. bore	Toothed belt pulley		D	D ₁	D ₂	l ₁	l ₃	l ₅	L	H=stroke
	DK1	DK2	SK1	SK2			d	T10 ¹⁾								
20	6-20	15-30	10-20	20-65	1500	20	T10, z = 24	AT10, z = 24	48	54	61.5	8	14	35	45	2
25	20-60	45-90	25-65	40-100	1500	25	T10, z = 30	AT10, z = 30	60	68	80	8	15	39	50	2
35	25-80	75-150	30-100	70-180	1000	35	T10, z = 36	AT10, z = 36	75	78	91	10	19	42	60	2
50	60-180	175-300	80-280	160-400	1000	50	T10, z = 48 ³⁾	AT10, z = 48 ³⁾	105	108	121	12	23	56	70	2

Dimensions – Hub design 4.5

Size	Max. bore	Dimensions [mm]						s	Clamping screws	Tightening torque T _A [Nm]
		d ₁	l ₆	l ₇	l ₈	l ₉	L ₁			
20	20	9	3.5	23	10	54	3	4 x M5	8.5	
25	25	11	4.0	28	11	61	4	4 x M6	14	
35	35	10	4.0	31	13	70	4	4 x M6	14	
50	50	12	4.0	37	14	82	6	4 x M6	14	

Transmittable friction torques T_R [Nm] (fitting tolerance H7/h6) of hub design 4.5

Size	Ø12	Ø14	Ø15	Ø16	Ø17	Ø18	Ø19	Ø20	Ø22	Ø23	Ø24	Ø25	Ø28	Ø30	Ø32	Ø35	Ø38	Ø40	Ø42	Ø45	Ø48	Ø50
20	45	62	71	81	92	103	115	127														
25		72	83	95	107	120	133	148	179	196	213	231										
35									127	139	152	165	207	237	270	323						
50																238	281	311	343	394	448	486

¹⁾ z = min. number of teeth required / Other sizes available on request

²⁾ See comments on page 245

³⁾ Without flanged wheel

Ordering example:

SYNTEX® 25	DK1	1.0	d Ø20	AT10, z = 24	32	45 Nm
Type/size	Type (DK/SK)	Hub design	Bore	Toothed belt pulley	Width of toothed belt pulley	Torque set

SYNTEX®

Backlash-free overload systems

With backlash-free ROTEX® GS



Hub design 1.0

Hub design 1.0

Hub design 6.0

Hub design 4.5

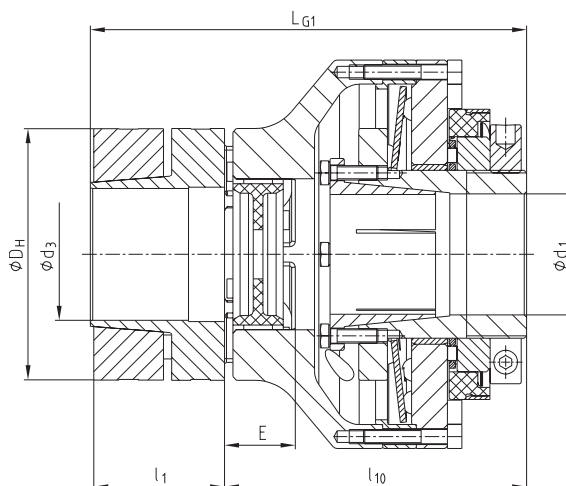
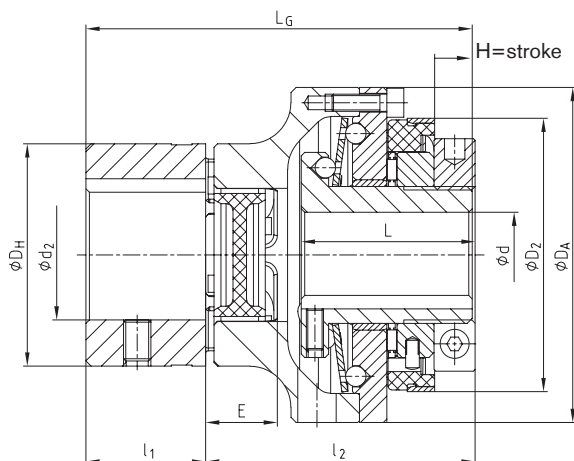

Technical data – dimensions

SYNTEX® size	ROTEX® GS size	Torques [Nm]							Max. speed ²⁾ [rpm]	Dimensions [mm]													
		Ratchet design DK		Synchronous design SK		ROTEX® GS ¹⁾ 98 ShA-GS		Max. bore				D ₂	D _H	D _A	l ₁	l ₂	l ₁₀	E	L	L _G	L _{G1}	H=stroke	
		DK1	DK2	SK1	SK2	T _{KN}	T _{K max}	d		d ₁	d ₂												d ₃
20	24	6-20	15-30	10-20	20-65	60	120	1500	20	20	28	28 ³⁾	61.5	55	80	30	70	83	18	45	100	113	2
25	28	20-60	45-90	25-65	40-100	160	320	1500	25	25	38	38 ³⁾	80	65	98	35	78	91	20	50	113	126	2
35	38	25-80	75-150	30-100	70-180	325	650	1000	35	35	45	48 ³⁾	91	80	120	45	91	105.5	24	60	136	150.5	2
50	48	60-180	175-300	80-280	160-400	525	1050	1000	50	50	62	55 ³⁾	121	105	162	56	111	126	28	70	167	182	2

Transmittable friction torques T_R [Nm] (fitting tolerance H7/h6) of hub design 4.5

Size	Ø12	Ø14	Ø15	Ø16	Ø17	Ø18	Ø19	Ø20	Ø22	Ø23	Ø24	Ø25	Ø28	Ø30	Ø32	Ø35	Ø38	Ø40	Ø42	Ø45	Ø48	Ø50
20	45	62	71	81	92	103	115	127														
25		72	83	95	107	120	133	148	179	196	213	231										
35									127	139	152	165	207	237	270	323						
50																238	281	311	343	394	448	486

¹⁾ See selection of ROTEX® GS couplings on page 22 et seqq.

²⁾ See comments on page 245

³⁾ For transmittable friction torques T_R [Nm] of ROTEX® GS hub type 2.8 or 6.0 refer to mounting instructions of ROTEX® GS

Ordering example:

SYNTEX® 25	DK1	1.0	d Ø20	ROTEX® GS 28	98 ShA-GS	1.0	d ₂ Ø25	50 Nm
Type/size	Type	Hub design	Bore	Type/size	Spider	Hub design	ROTEX® GS bore	Torque set

SYNTEX[®]-NC / KTR-SI Compact Backlash-free overload systems

Structure and operation

The design of the backlash-free overload systems SYNTEX[®]-NC and KTR-SI Compact is based on a spring-preloaded and positive-locking ball-ratchet-principle allowing for a high repeating accuracy and short reaction times. Moreover, an integrated groove ball bearing provides for the option of direct assembly of toothed belt pulleys, special flanges or other components. Main applications are latest machine tools, control and positioning technology as well as packaging machines and special purpose machinery.

Both systems make use of disk springs with a declining spring characteristic curve the preset prestress of which drops during the disengaging process. As a result driving and driven end are reliably separated from each other within some milliseconds with the wear on the components being reduced to a minimum simultaneously.

Spring characteristic curve

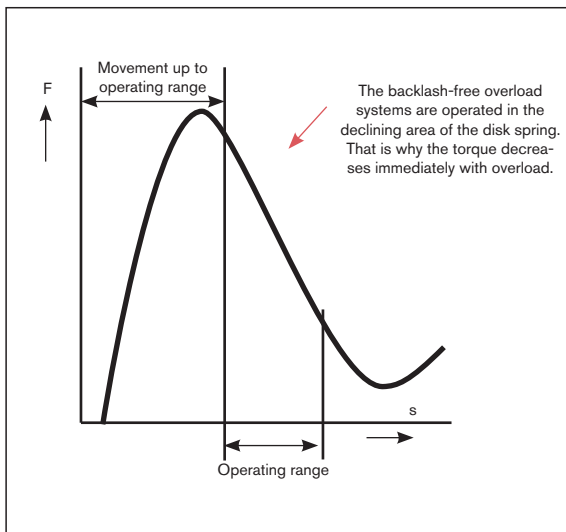

What does backlash-free mean?

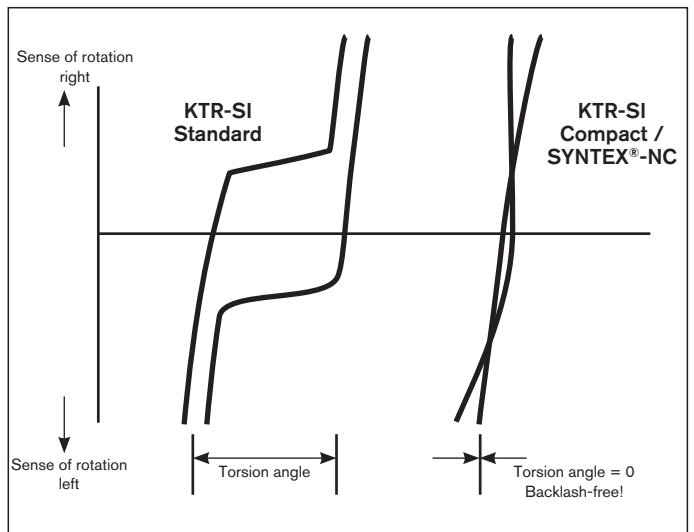

Ratchet design DK

Any engagement after an overload. After eliminating the overload, the balls engage automatically with the next following ball indentation.

Synchronous design SK

Synchronous engagement after an overload. After eliminating the overload, the balls re-engage automatically with the disk springs after a rotation of 360°. Driving and driven side are always placed in the same position to each other. Other degrees of re-engagement, for example 180°, are also possible.

 = The core of the backlash-free overload systems

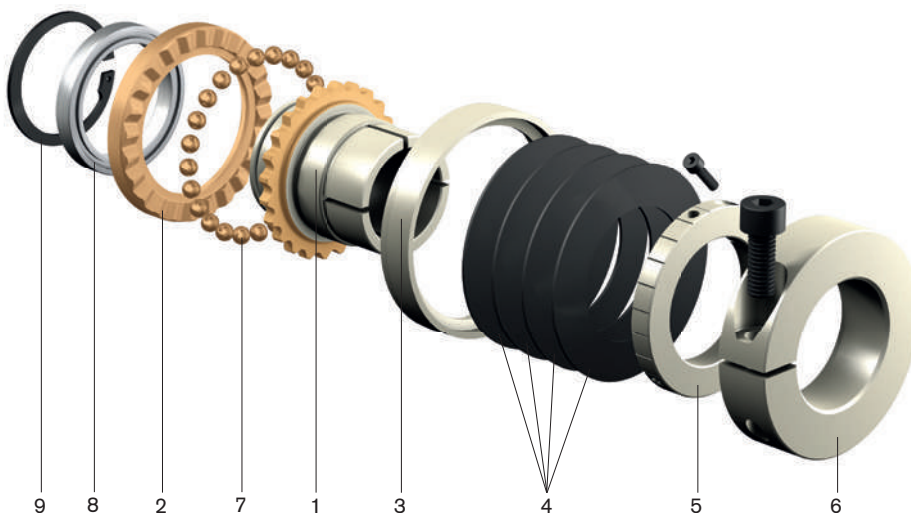

List of components:

1. Hub with keyway to DIN (type 1.0) or with clamping ring (type 6.1)
2. Flange ring
3. Shifting ring
4. Disk spring
5. Setting nut
6. Clamping ring
7. Balls
8. Groove ball bearing
9. Circlip

SYNTEX®-NC / KTR-SI Compact Backlash-free overload systems

Operating principle

- Overload protection up to 550 Nm
- Backlash-free torque transmission
- Light-weight design
- Declining spring characteristic
- Low mass moment of inertia
- Large bore diameters
- Short reaction times
- High power density

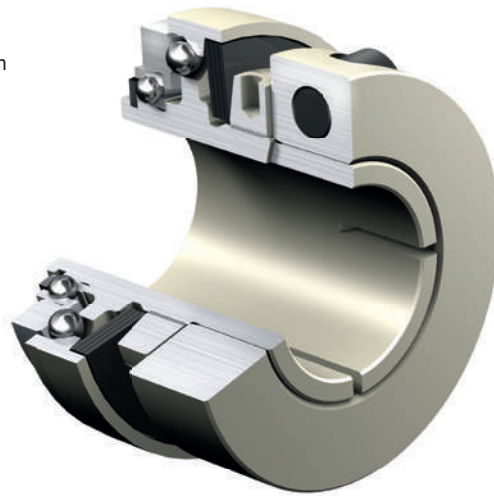

- Clamping ring design easy to assemble
- Available both as a ratchet (DK) and synchronous design (SK)
- Backlash-free shaft-hub-connection
- In combination with the backlash-free ROTEX® GS or backlash-free, torsionally rigid TOOLFLEX®
- Direct assembly of toothed belt pulley, as an example, possible (integrated groove ball bearing)

- Overload protection up to 3,100 Nm
- Backlash-free overload system with a declining spring characteristic
- Solid design
- Accurate disengagement with high repeating accuracy
- Accurate backlash-free torque transmission even in case of wear
- Shifting ring with setting scale for accurate torque setting



- Easy torque setting by torque scale on the coupling
- Connection flange with ball bearing
- Hardened ratchet surfaces for a long service life
- Backlash-free shaft-hub-connection via taper bush
- Can be used with the proven ROTEX® GS as a shaft-to-shaft connection

RUFLEX®

KTR-SI

SYNTEX®

SYNTEX®-NC

KTR-SI Compact

Torque
limiters

SYNTEX®-NC

Backlash-free overload systems

Hub design

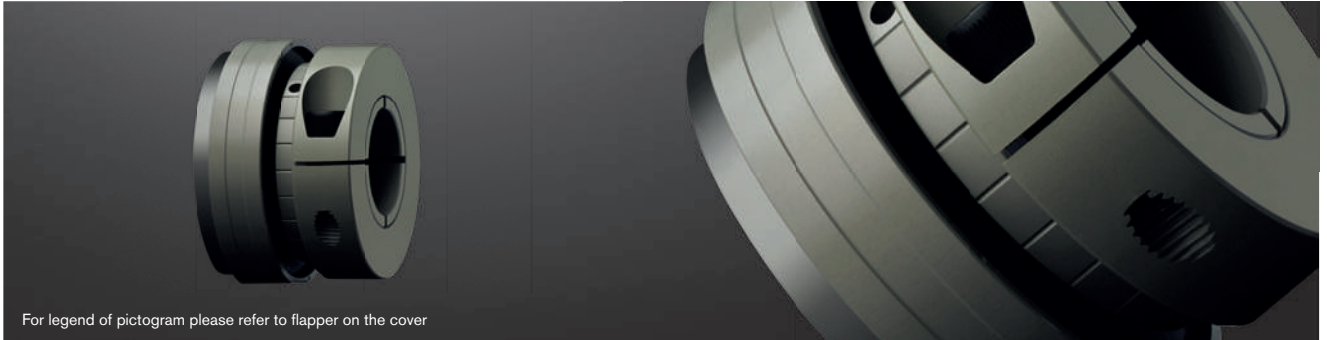

For legend of pictogram please refer to flapper on the cover



Hub design 1.0 (keyway acc. to DIN 6885)

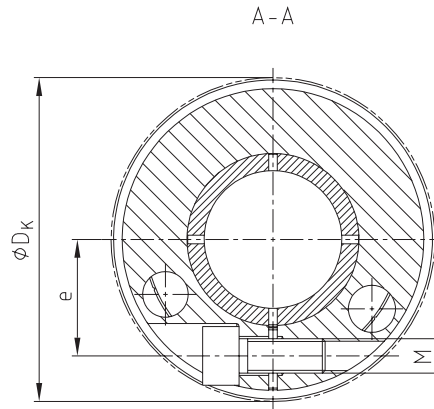
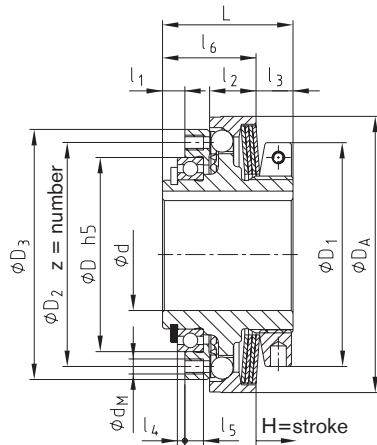

Hub design 6.1 (clamping ring)

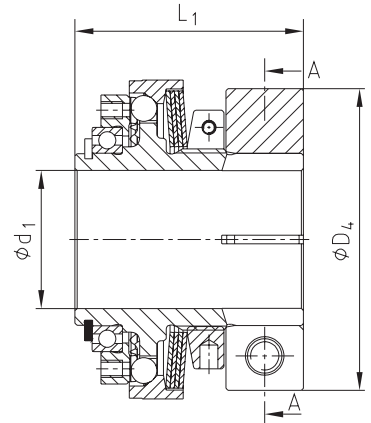

Technical data – dimensions

Size	Max. speed ³⁾ [rpm]	Torques [Nm]			Max. bore d	Dimensions [mm]											H=stroke		
		T1	T2	T3		D _{h5}	D ₁	D ₂	D ₃	D _A	l ₁	l ₂	l ₃	l ₄	l ₅	l ₆		L	z x d _M
15	3500	2-3.5	3.5-7	7-14	12	32	33	37	42	42	5.0	7.0	9.2	2	4	18.8	28	12xM3	0.8
25	3000	9-15	20-35	40-65	19 (22) ¹⁾	42	50	48	56	61	5.5	11.5	9.1	2	5	23.9	33	8xM4	1.2
32	3000	25-38	50-75	100-150	27 (30) ¹⁾	52	60	60	67	74	6	12.5	9.9	2	5	25.1	35	8xM4	1.5
42	2500	30-65	60-135	120-265	36 (38) ¹⁾	65	72	75	83	90	7	16	11.2	2	6	31.8	43	8xM5	1.5
60 ⁴⁾	2000	70-140	120-180	220-550	50	90	96	100	113	116	8	21	11.8	2	7	38.2	52	12xM6	1.8

Dimensions – Hub design 6.1

Size	Bore d ₁		Dimensions [mm]						T _A [Nm]	Weight with max. bore [kg]	Mass moment of inertia ²⁾ J _{total} [kgm ²]
	Pilot bore	Max.	D ₄	D _K	L ₁	e	M				
15	7.5	15	40	43	38	15	M4	1.7	0.124	0.029 x 10 ⁻³	
25	9.5	25	55	-	45	21	M6	14	0.282	0.14 x 10 ⁻³	
32	13.5	32	70	-	53	27	M8	34	0.471	0.35 x 10 ⁻³	
42	18.5	42	86	91.2	63	33	M10	67	0.815	0.95 x 10 ⁻³	
60 ⁴⁾	24	60	112	119.4	75	45	M12	115	3.04	5.9 x 10 ⁻³	

Transmittable friction torques T_R [Nm] (fitting tolerance H7/h6) of hub design 6.1

Size	Ø8	Ø10	Ø11	Ø12	Ø14	Ø15	Ø16	Ø18	Ø19	Ø20	Ø22	Ø24	Ø25	Ø28	Ø30	Ø32	Ø35	Ø36	Ø38	Ø40	Ø42	Ø45	Ø48	Ø50	Ø55	Ø60
15	8	12	14	16	22	24																				
25		30	35	42	55	62	69	48	53	58	69	80	86													
32						74	83	104	114	125	148	116	125	153	172	192										
42										149	178	209	225	275	310	264	309	324	356	389	422					
60 ⁴⁾													247	310	356	405	485	513	571	633	394	452	514	558	675	803

¹⁾ The figure in brackets specifies the max. bore with keyway to DIN 6885 sheet 3 (low-rise design)

²⁾ With max. bore

³⁾ See comments on page 245

⁴⁾ Material steel

Ordering example:

SYNTEX®-NC 32	SK	6.1	T3	d ₁ Ø25	120
Type/size	Type (DK/SK)	Hub design	Disk springs	Bore	Torque set

SYNTEX®-NC

Backlash-free overload systems

With backlash-free ROTEX® GS

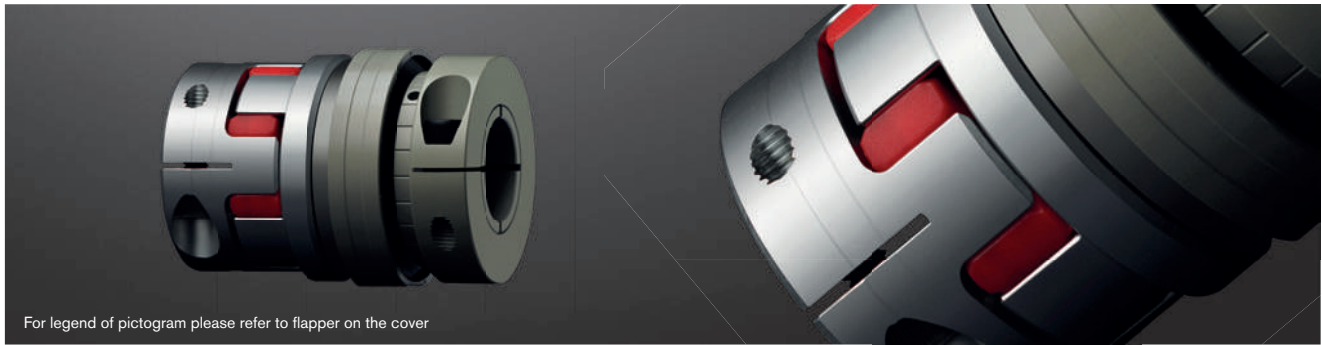

For legend of pictogram please refer to flapper on the cover



LG1 = Hub design 2.8 from size 60 6.0 light
LG2 = Hub design 2.5/2.6

Hub design 6.1

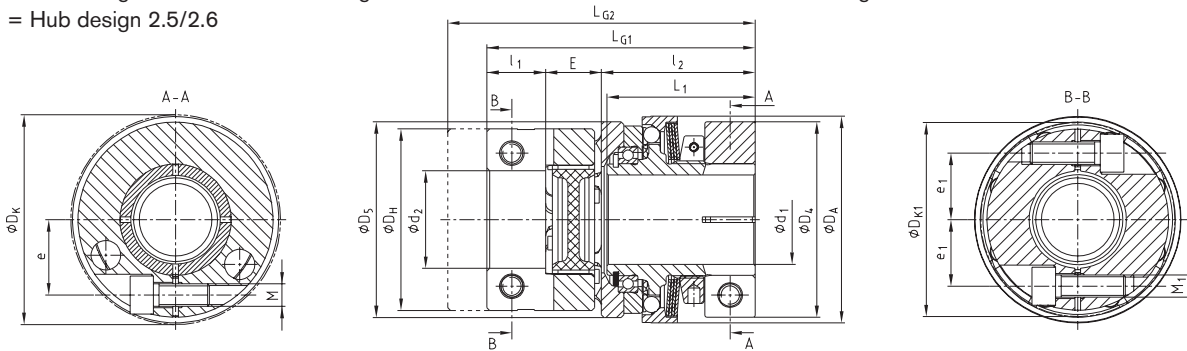

LG = Hub design 2.9 from size 60 1.0
LG3 = Hub design 2.5/2.6

Hub design 1.0

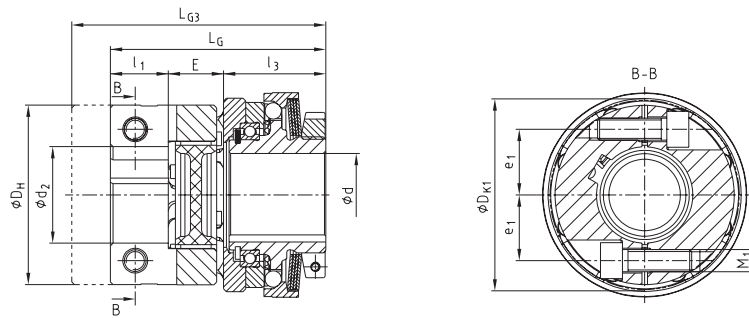

Technical data – dimensions

Size	ROTEX® GS size ¹⁾	Torques [Nm]			Max. speed ²⁾ [rpm]	Max. bore			Dimensions [mm]																			
		T1	T2	T3		d	d ₁	d ₂	D ₅	D _H	DK	DK1	D _A	l ₁	l ₂	l ₃	E	e	e ₁	LG	L ₁	LG1	LG2	LG3	M	T _A [Nm]	M ₁	T _{A1} [Nm]
15	19	2-3.5	3.5-7	7-14	3500	12	15	24 ³⁾	45	40	-	46.7	42	17	40	30	16	15	15.5	63	38	73	81	71	M4	1.7	M5	6
25	24	9-15	20-35	40-65	3000	19 (22) ⁴⁾	25	32 ³⁾	58	55	-	57.5	61	18	47.5	35.5	18	21	20	71.5	45	83.5	95.5	83.5	M6	14	M6	10
32	28	25-38	50-75	100-150	3000	27 (30) ⁴⁾	32	35 ³⁾	70	65	-	69	74	21	55	37	20	27	23.8	78	53	96	110	92	M8	34	M8	25
42	38	30-65	60-135	120-265	2500	36 (38) ⁴⁾	42	45 ³⁾	88	80	91.2	86	90	26	66	46	24	33	30.5	96	63	116	135	115	M10	67	M10	49
60 ⁵⁾	48	70-140	120-280	220-550	2000	50	60	55 ³⁾	113	105	119.4	-	116	56	83	60	28	45	-	144	75	167	144	M12	115	M10	49	

Transmittable friction torques T_R [Nm] (fitting tolerance H7/h6) of hub design 6.1

Size	Ø8	Ø10	Ø11	Ø12	Ø14	Ø15	Ø16	Ø18	Ø19	Ø20	Ø22	Ø24	Ø25	Ø28	Ø30	Ø32	Ø35	Ø36	Ø38	Ø40	Ø42	Ø45	Ø48	Ø50	Ø55	Ø60
15	8	12	14	16	22	24																				
25		30	35	42	55	62	69	48	53	58	69	80	86													
32					74	83	104	114	125	148	116	125	153	172	192											
42									149	178	209	225	275	310	264	309	324	356	389	422						
60 ⁵⁾													247	310	356	405	485	513	571	633	394	452	514	558	675	803

¹⁾ See selection of ROTEX® GS couplings on page 22 et seqq.

²⁾ See comments on page 245

³⁾ For transmittable friction torques T_R [Nm] of ROTEX® GS hub type 2.8 or 6.0 refer to mounting instructions of ROTEX® GS

⁴⁾ The figure in brackets specifies the max. bore with keyway to DIN 6885 sheet 3 (low-rise design)

⁵⁾ Material steel

Ordering example:	SYNTEX®-NC 32	SK	6.1	T3	d ₁ Ø25	28	2.8	d ₂ Ø20	120
	Type/size	Type	Hub design	Disk springs	SYNTEX®-NC bore	ROTEX® GS size	Hub design	ROTEX® GS bore	Torque set

SYNTEX®-NC

Backlash-free overload systems

With torsionally rigid TOOLFLEX® S

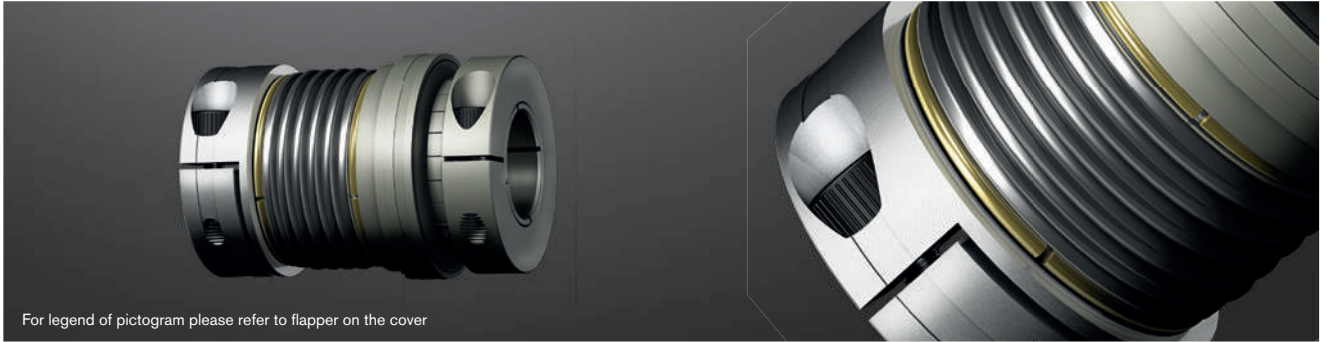

For legend of pictogram please refer to flapper on the cover

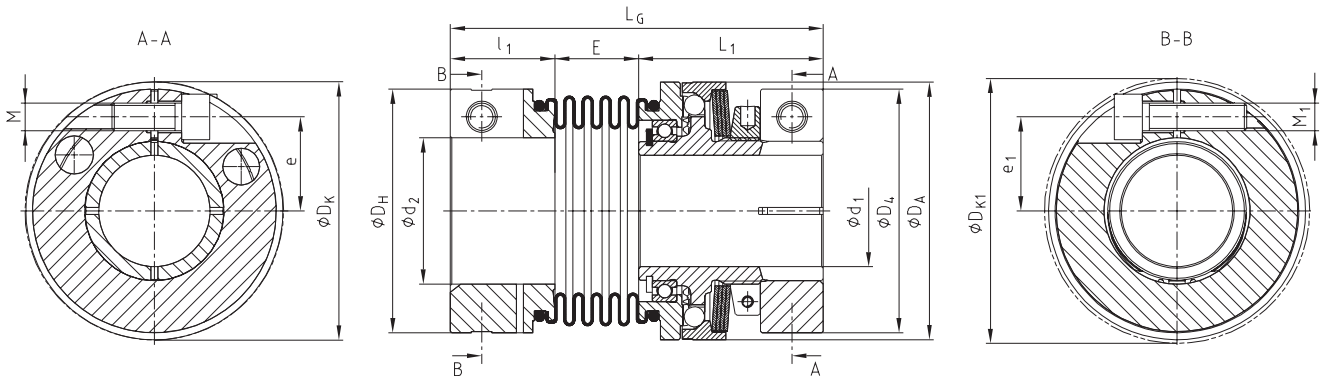

Technical data – dimensions																							
Size	TOOLFLEX® size ¹⁾	Torques [Nm]			Speed ²⁾ [rpm]	Max. bore		Dimensions [mm]															
		T1	T2	T3		d ₁	d ₂	D ₄	D _H	D _A	D _K	D _{K1}	l ₁	L ₁	E	e	e ₁	L _G	M	T _A [Nm]	M ₁	T _{A1} [Nm]	
15	20	2-3.5	3.5-7	7-14	3500	15	20 ³⁾	40	40	52	43	43.5	21.5	38	16.5	15	14.5	76	M4	1.7	M5	6	
25	38	9-15	20-35	40-65	3000	25	38 ³⁾	55	65	61	-	72.6	25.5	45	18	21	25	88	M6	14	M8	25	
32	42	25-38	50-75	100-150	3000	32	42 ³⁾	70	70	74	-	76.1	30	53	24	27	27	107	M8	34	M8	25	
42	45	30-65	60-135	120-265	2500	42	45 ³⁾	86	83	90	91.2	89	32	63	22.5	33	30	114	M10	67	M10	49	
60 ⁴⁾	65	70-140	120-280	220-550	2000	60	65 ³⁾	112	125	140	119.4	127.1	45	84	36	45	45	165	M12	115	M14	185	

Transmittable friction torques T _R [Nm] (fitting tolerance H7/h6) of hub design 6.1																										
Size	Ø8	Ø10	Ø11	Ø12	Ø14	Ø15	Ø16	Ø18	Ø19	Ø20	Ø22	Ø24	Ø25	Ø28	Ø30	Ø32	Ø35	Ø36	Ø38	Ø40	Ø42	Ø45	Ø48	Ø50	Ø55	Ø60
15	8	12	14	16	22	24																				
25		30	35	42	55	62	69	48	53	58	69	80	86													
32					74	83	104	114		125	148	116	125	153	172	192										
42										149	178	209	225	275	310	264	309	324	356	389	422					
60 ⁴⁾													247	310	356	405	485	513	571	633	394	452	514	558	675	803

¹⁾ See selection of TOOLFLEX® couplings on page 22 et seqq.
²⁾ See comments on page 245
³⁾ For transmittable friction torques T_R [Nm] of TOOLFLEX® hub type 2.5 refer to mounting instructions of TOOLFLEX®
⁴⁾ Material steel

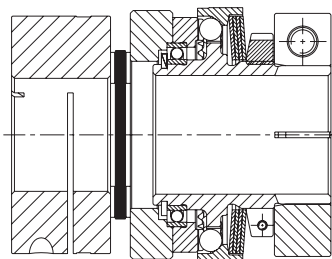

Special type:

- SYNTEX®-NC with RADEX®-NC

Ordering example:	SYNTEX®-NC 32	SK	6.1	T3	d ₁ Ø25	42-S	2.5	d ₂ Ø20	120
	Type/size	Type	Hub design	Disk springs	SYNTEX®-NC bore	TOOLFLEX® size	Hub design	TOOLFLEX® bore	Torque set

KTR-SI Compact

Backlash-free overload systems

Flange type



For legend of pictogram please refer to flapper on the cover



RUFLEX®

KTR-SI

Hub design 1.0

Hub design 4.5
with taper bush

Size 01 - 3

Size 4

Size 01 - 3

Size 4

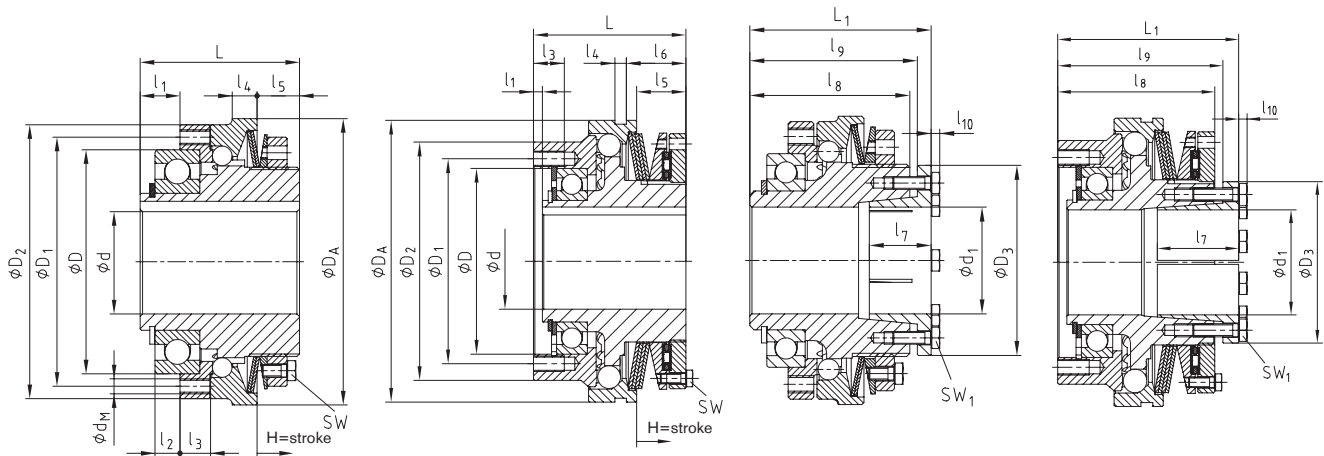

SYNTEX®

Technical data – dimensions

Size	Speed ¹⁾ [rpm]	Torque [Nm]			Dimensions [mm]														
		T1	T2	T3	Bore		D _{h5}	D ₁	D ₂	D _A	l ₁	l ₂	l ₃	l ₄	l ₅	l ₆	L	d _M	SW
01	4000	3-14	6-28	13-56	d	47	56	65	70	8	5	7.5	7	12	-	40	8xM4	7	1.2
0	3000	9-35	18-70	40-140	10-25	62	71	80	85	11	7	8.0	8	14	-	48	8xM5	7	1.5
1	2500	19-65	38-130	78-260	14-30	75	85	95	100	14	9	10.5	9	16	-	59	8xM6	8	1.8
2	2000	35-110	80-220	160-440	18-40 (45) ³⁾	90	100	110	115	16	10	12	10	17	-	64	8xM6	10	2.0
3	1200	80-210	160-400	320-800	24-50	100	116	130	135	18	10	12	12	21	-	75	8xM8	10	2.2
4	400	230-730	460-1590	960-3100	40-75	145 ^{H7}	160	186	220	7	-	24	9	38.5	46.5	119	6xM12	13	3.5

SYNTEX®-NC

Torque
limiters

Dimensions – Hub design 4.5

Size	Bore ²⁾		Dimensions [mm]							T _A [Nm]
	d ₁	D ₃	l ₇	l ₈	l ₉	l ₁₀	L ₁	SW ₁		
01	10-20	40.5	26	40	42	2.8	47	7	3	
0	19-30	57	31	46	49	4.0	56	10	10	
1	19-30	57	40	57	60	4.0	67	10	10	
	32-40	64	31			3.5		8	5.9	
2	32-50	73.5	29	63	68.5	4.0	73	10	10	
3	32-50	73.5	29	75	78.5		85			
	55-60	89	44		78.0	4.0	86	10	10	
4	60-80	123	62	119	126	7	138	16	35	

¹⁾ See comments on page 245

²⁾ For transmittable friction torques T_R [Nm] of hub type 4.5 please refer to assembly instructions

³⁾ The figure in brackets specifies the max. bore with keyway to DIN 6885 sheet 3 (low-rise design)

Ordering example:

KTR-SI Compact 2	DK	4.5	T2	d ₁ Ø40	150 Nm
Type/size	Type (DK/SK)	Hub design	Disk springs	Bore	Torque set

KTR-SI Compact

KTR-SI Compact

Backlash-free overload systems

With backlash-free ROTEX® GS

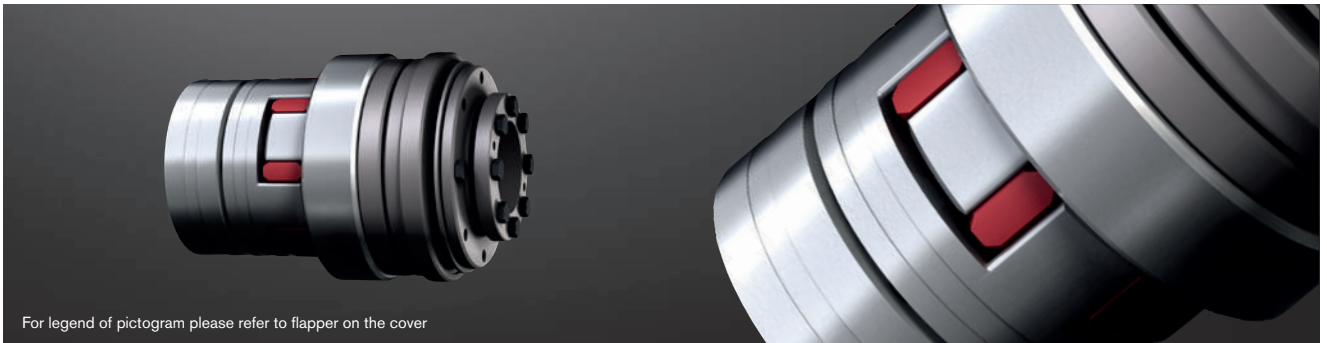

For legend of pictogram please refer to flapper on the cover

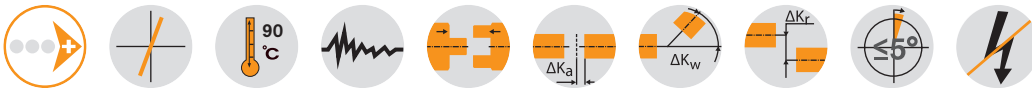

Hub design 1.0

Hub design 1.0

Hub design 6.0

Hub design 4.5

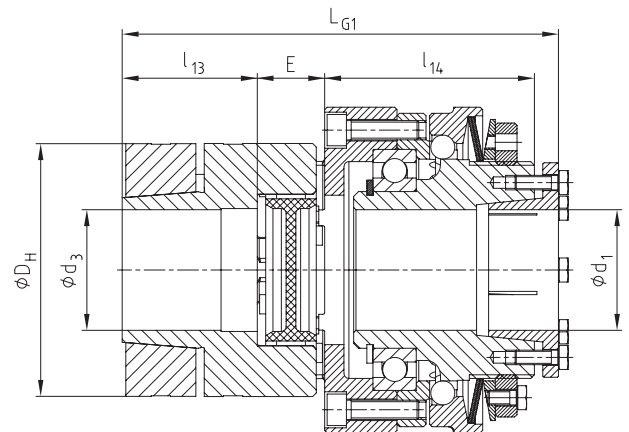
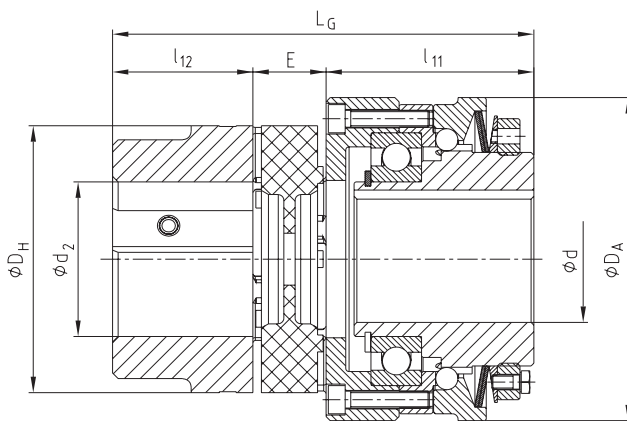

Technical data – dimensions

Size	Max. speed ¹⁾ [rpm]	Torques [Nm]			ROTEX® GS size ²⁾	Max. bore				Dimensions [mm]								
		T1	T2	T3		d	d ₁	d ₂	d ₃	D _H	D _A	l ₁₁	l ₁₂	l ₁₃	l ₁₄	E	L _G	L _{G1}
01	4000	3-14	6-28	13-56	24	20	25	28	28	55	70	47	30	30	47	18	95	102
0	3000	9-35	18-70	40-140	28	25	30	38	38	65	85	56.5	35	35	54.5	20	111.5	119.5
1	2500	19-65	38-130	78-260	38	30	40	45	45	80	100	69	45	45	67	24	138	146
2	2000	35-110	80-220	160-440	42	40 (45) ³⁾	50	55	55	95	115	74	50	50	73	26	150	159
3	1200	80-210	160-400	320-800	48	50	60	62	62	105	135	87	56	56	87	28	171	182
4	400	230-730	460-1590	960-3100	75	75	80	80	80	160	220	158.5	85	85	139.5	40	283.5	302.5

¹⁾ See comments on page 245

²⁾ See selection of ROTEX® GS couplings on page 22 et seqq.

³⁾ The figure in brackets specifies the max. bore with keyway to DIN 6885 sheet 3 (low-rise design)

Ordering
example:

KTR-SI Compact 1	DK	T2	4.5	d ₁ Ø25	6.0 / d ₃ Ø25	150 Nm
Type/size	Type (DK/SK)	Disk spring	KTR-SI hub design	KTR-SI bore	ROTEX® GS hub design/bore	Torque set

Special types

Other types and combinations available on request.

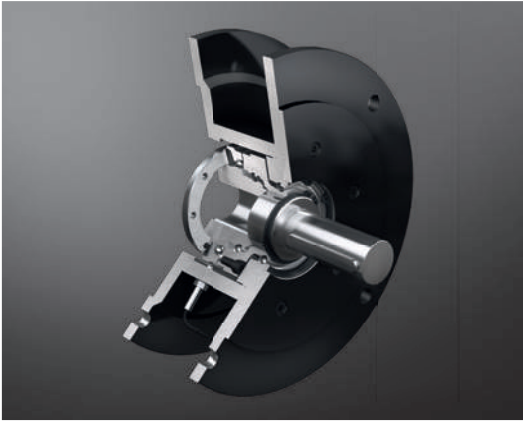

- KTR-SI Compact with IEC flange

RUFLEX®

KTR-SI

SYNTEX®

SYNTEX®-NC

Torque
limiters

KTR-SI Compact

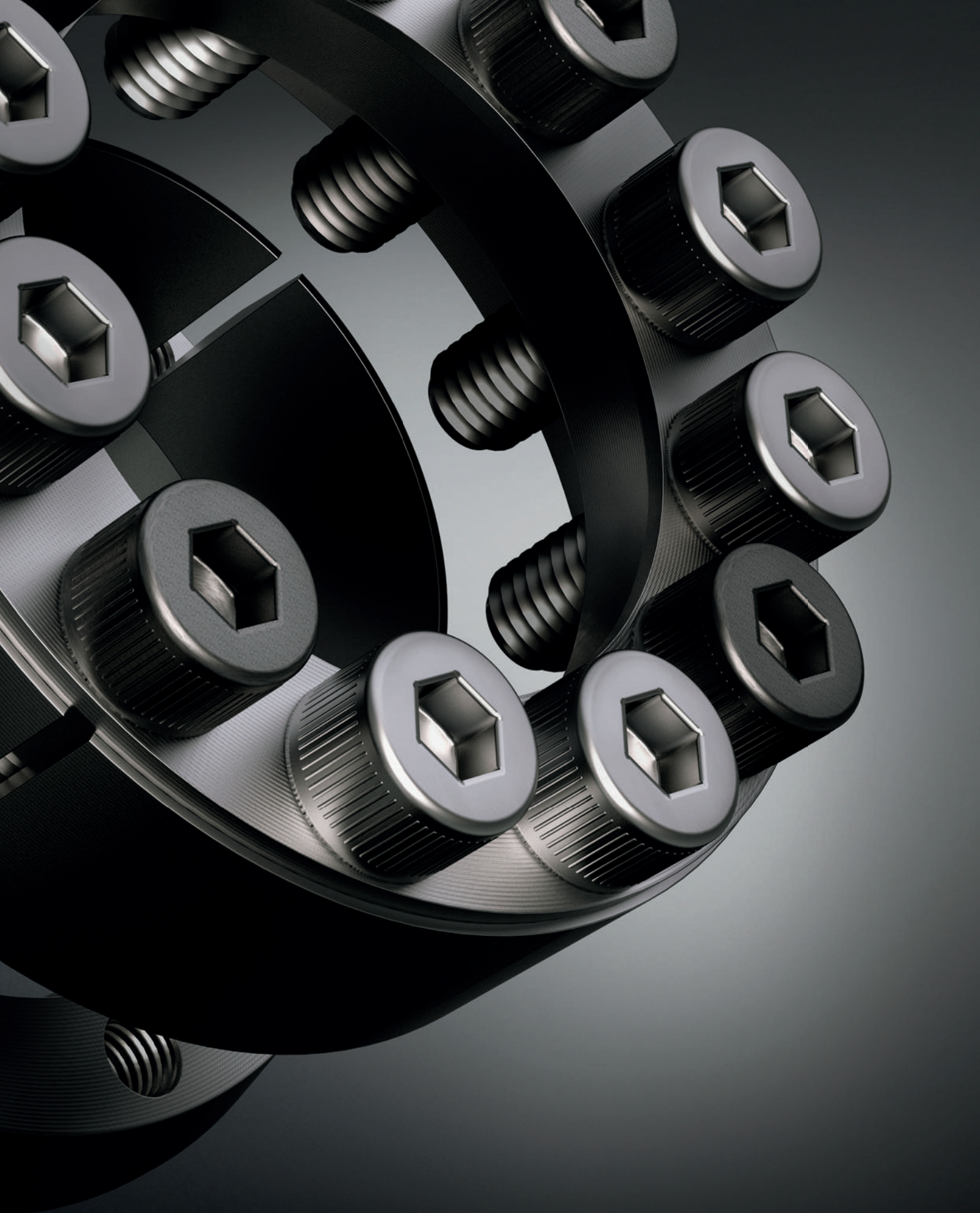

Clamping elements and precision joints

CLAMPEX®

Types of clamping elements	280
Selection	282
Selection guide	284
Calculation of hubs	285
KTR 100	286
KTR 105	288
KTR 130 and KTR 131	290
KTR 150	292
KTR 200 and KTR 201	294
KTR 203 and KTR 206	296
KTR 225	298
KTR 250	300
KTR 400	302
KTR 603	306
KTR 620	308
KTR 700	312

KTR Clamping nuts

Large screw connections for easy and quick assembly	314
--	-----

KTR Precision joints

Selection and sizing	316
Type G and GD with plain bearing	318
Type H and HD with needle bearing	319
Type GA and HA plain and needle bearing (extendable)	320
Type X and XD with plain bearing made of stainless steel	321
Type GR and HR with quick locking	322
Accessories (protection bushings)	323

Internal clamping elements



External clamping elements



Shaft couplings



Precision joints



CLAMPEX® CLAMPING ELEMENTS TYPES AND OPERATING DESCRIPTION

Properties of clamping elements

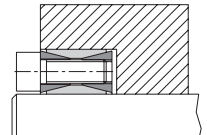
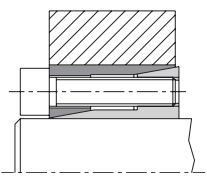
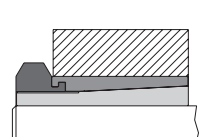
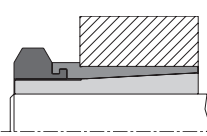
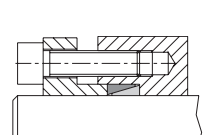
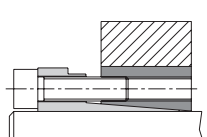
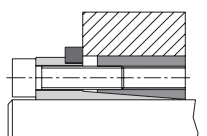
Type	Series	Shaft diameter [mm]	Transmittable torque T [Nm]	Centering of hub versus shaft via the clamping element	Centering between hub and shaft required	Axial displacement of hub during assembly of clamping element	Details on page
Internal clamping elements	 KTR 100	17 – 1,000	260 – 3,017,100		●		286 287
	 KTR 105	5 – 50	5 – 1,900	●		●	288 289
	 KTR 130	5 – 50	10 – 2,320	●		●	290 291
	 KTR 131	5 – 35	10 – 836	●		●	290 291
	 KTR 150	6 – 440	2 – 215,000		●	●*	292 293
	 KTR 200	20 – 200	530 – 68,000	●		●	294 295
	 KTR 201	20 – 200	320 – 48,800	●			294 295

* Depending on mounting position

CLAMPEX® CLAMPING ELEMENTS

TYPES AND OPERATING DESCRIPTION

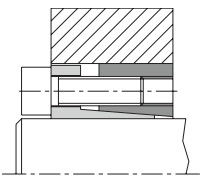
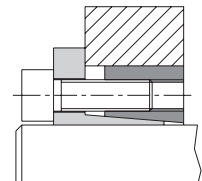
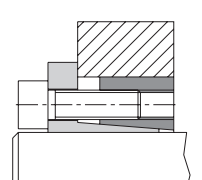
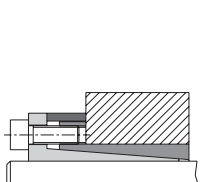
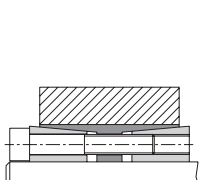
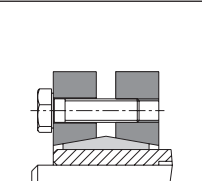
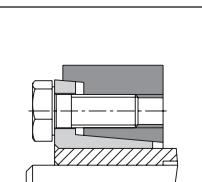
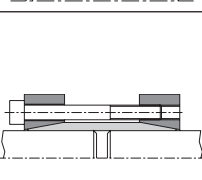
Type	Series	Shaft diameter [mm]	Transmittable torque T [Nm]	Centering of hub versus shaft via the clamping element	Centering between hub and shaft required	Axial displacement of hub during assembly of clamping element	Details on page
Internal clamping elements	 KTR 203	18 – 400	370 – 487,000	●		●	296 297
	 KTR 206	18 – 400	290 – 342,000	●			296 297
	 KTR 225	14 – 50	287 – 1,796	●			298 299
	 KTR 250	6 – 130	11 – 25,000	●			300 301
	 KTR 400	24 – 600	700 – 1,640,000	●		●	302 303
External clamping elements	 KTR 603	10 – 420	28 – 1,460,000	●			304 - 307
	 KTR 620	13 – 700	70 – 7,394,000	●			308 - 311
Shaft couplings	 KTR 700	10 – 100	62 – 8,350	●			312 313

CLAMPEX®

Clamping nuts

KTR Precision joints

Clamping sets

Guide for selection

1. Which properties of a clamping set are required?

- Shall shaft and hub be centered versus each other through the clamping set?
- Is axial displacement of hub permissible during assembly of the clamping set?

For an explanation of the properties specified above see CLAMPEX® selection guide on page 284.

2. Which dimensions of clamping sets are required?

- Internal diameter of clamping set = shaft diameter
- External diameter of clamping set = diameter of hub bore
- Length of clamping set

For dimensions of clamping sets see catalogue on page 287 et seqq.

3. How much torque and/or axial force needs to be transmitted?

The following safety factors are recommended by KTR:

- ≥ 1.5 between the maximum torque/axial force of machine and the transmittable torque/axial force of clamping set.
- ≥ 2.0 between the rated torque/axial force of machine and the transmittable torque/axial force of clamping set.

4. Is the wall thickness of the hubs sufficient?

Calculation of wall thickness of the hubs is possible via the following methods:

- For formula for calculating the necessary outside diameter of hubs see page 284.
- For calculating the necessary outside diameter of hub via correction factor see page 285.

5. Other selection criteria

Please consult with KTR.

- The clamping set is to be mounted on a shaft with a feather keyway.
- Simultaneous transmission of torque and axial force.
- The clamping set is radially loaded.
- The clamping set is subject to bending.
- High circumferential speeds (from 30 m/s).
- High operating temperatures.
- Shaft with bore (hollow shaft).
- Clamping set in a corrosion-protected design.

Selection

Use in potentially explosive atmospheres

The power transmission of CLAMPEX® clamping elements is based on the principle of two taper rings twisted into each other. Axial force generated on the rings (by means of several screws) produces surface pressure inside the shaft and outside the hub which allows for frictionally engaged transmission of the torque. Considering all operating data (intended use) a potential source of ignition does not exist. That is why clamping elements do not come within the scope of directive 2014/34/EU.

Due to the aforementioned design of CLAMPEX® clamping elements a failure of components does not have to be expected. A risk only arises if friction heat is generated with slipping of a clamping connection (improper assembly/tightening torques).

Concentricity

The concentricity of the self-centering CLAMPEX® clamping elements is between 0.02 mm and 0.08 mm. This concentricity is not reproducible due to the slotted individual components of the clamping elements. As a result this figure merely serves for supporting with designing.

Table of screws						
Dimension M	Preload force F_V and tightening torque T_A with $\mu_{total} = 0.14$					
	Preload force F_V [N]			Tightening torque T_A [Nm]		
	8.8	10.9	12.9	8.8	10.9	12.9
M3	2210	3110	3730	1.34	1.89	2.25
M4	3900	5450	6550	2.9	4.1	4.9
M5	6350	8950	10700	6	8.5	10
M6	9000	12600	15100	10	14	17
M8	16500	23200	27900	25	35	41
M10	26200	36900	44300	49	69	83
M12	38300	54000	64500	86	120	145
M14	52500	74000	88500	135	190	230
M16	73000	102000	123000	210	295	355
M18	88000	124000	148000	290	405	485
M20	114000	160000	192000	410	580	690
M22	141000	199000	239000	550	780	930
M24	164000	230000	276000	710	1000	1200
M27	215000	302000	363000	1050	1500	1800
M30	262000	368000	442000	1450	2000	2400

Selection

Symbol	Definition or explanation
$\sigma_{N0,2}$	Yield point of hub material [N/mm ²]
$\sigma_{W0,2}$	Yield point of shaft material [N/mm ²]
C	Value C of hub design (see illustration on page 269)
d	Internal diameter of clamping element [mm]
d_{iW}	Internal diameter of hollow shaft [mm]
D	External diameter of clamping element [mm]
D_N	External diameter of hub required [mm]
T	Transmittable torque [Nm]
T_S	Peak torque to be transmitted [Nm]
T_A	Screw tightening torque [Nm]
B2/B3	Length of clamping element [mm]

Symbol	Definition or explanation
L/L ₁	Hub length [mm]
P_N	Surface pressure generated on the clamping element/hub [N/mm ²]
P_W	Surface pressure generated on the clamping element/shaft [N/mm ²]
C _W	d_{iW}/d -> Ratio of internal diameter of hollow shaft/clamping element
C_N	D/D_N -> Ratio of external diameter of clamping element/hub
F_a	Axial force generated during operation [kN]
F_{ax}	Transmittable axial force [kN]
F_V	Preload force [N]
P_O	Setting force for clamping element [N]
P_S	Clamping force for clamping element [N]
P_A	$P_O + P_S$ = Total force for clamping element [N]

The transmission data are parameters found out by calculations. Subject to the friction coefficient variation which is subjected to physical properties, small deviations with the transmission figures may arise.

1. Fatigue strength and shape stability of components subject to torsion and bending load

The stress concentration figures β_k for the clamping elements press fittings are worked out similar to those of hydraulic fittings. Stress concentration factors on request.

2. Transmittable torque T

The transmittable torque T always has to be above the biggest torque peak T_S , which may arise on the joints. The torque peaks occurring with acceleration of electric motors as well as additional axial forces F_a have to be considered.

$$T \geq \sqrt{T_S [Nm]^2 + (F_a [kN] \cdot \frac{d [mm]}{2})^2}$$

3. Transmittable axial force F_{ax}

The maximum transmittable axial force F_{ax} specified in the tables has to be reduced accordingly with additional torque transmission.

$$F_{ax} [kN] = 2 \cdot \frac{T [Nm]}{d [mm]}$$

4. Calculation of external diameter of hub D_N

The external diameter of hub D_N required depends on the hub geometry, the yield point of the hub material and the surface pressure between clamping element and hub. In order to simplify the calculation, the table on page 269 specifies correction values which allow to calculate D_N .

$$D_N [mm] \geq D \cdot \text{correction value } x$$

Those external diameters of hubs which cannot be calculated based on the table are calculated via the following formula:

$$D_N \geq D \cdot \sqrt{\frac{\sigma_{N0,2} + P_N \cdot C}{\sigma_{N0,2} - P_N \cdot C}}$$

Tangential stress on the internal diameter of hub

$$\sigma_{tiN} \approx P_N \cdot \frac{(1 + C_N^2)}{(1 - C_N^2)} \cdot C$$

For clamping connections with hollow shafts the required internal diameter of the hollow shaft d_{iW} is calculated based on the following formula:

$$d_{iW} \leq d \cdot \sqrt{\frac{\sigma_{W0,2} - 2 \cdot P_W \cdot 0.8}{\sigma_{W0,2}}}$$

Tangential stress on the internal diameter of shaft

$$\sigma_{tiW} \approx \frac{2 \cdot P_W}{(C_W^2 - 1)}$$

Selection of hub material with external clamping sets KTR 603 and KTR 620

The hub material should have a yield strength Re of ≥ 350 N/mm². For applications with additional bending load, Q + T steel such as 42CrMo4 should be used.

Selection guide

Selection guide for CLAMPEX® clamping elements

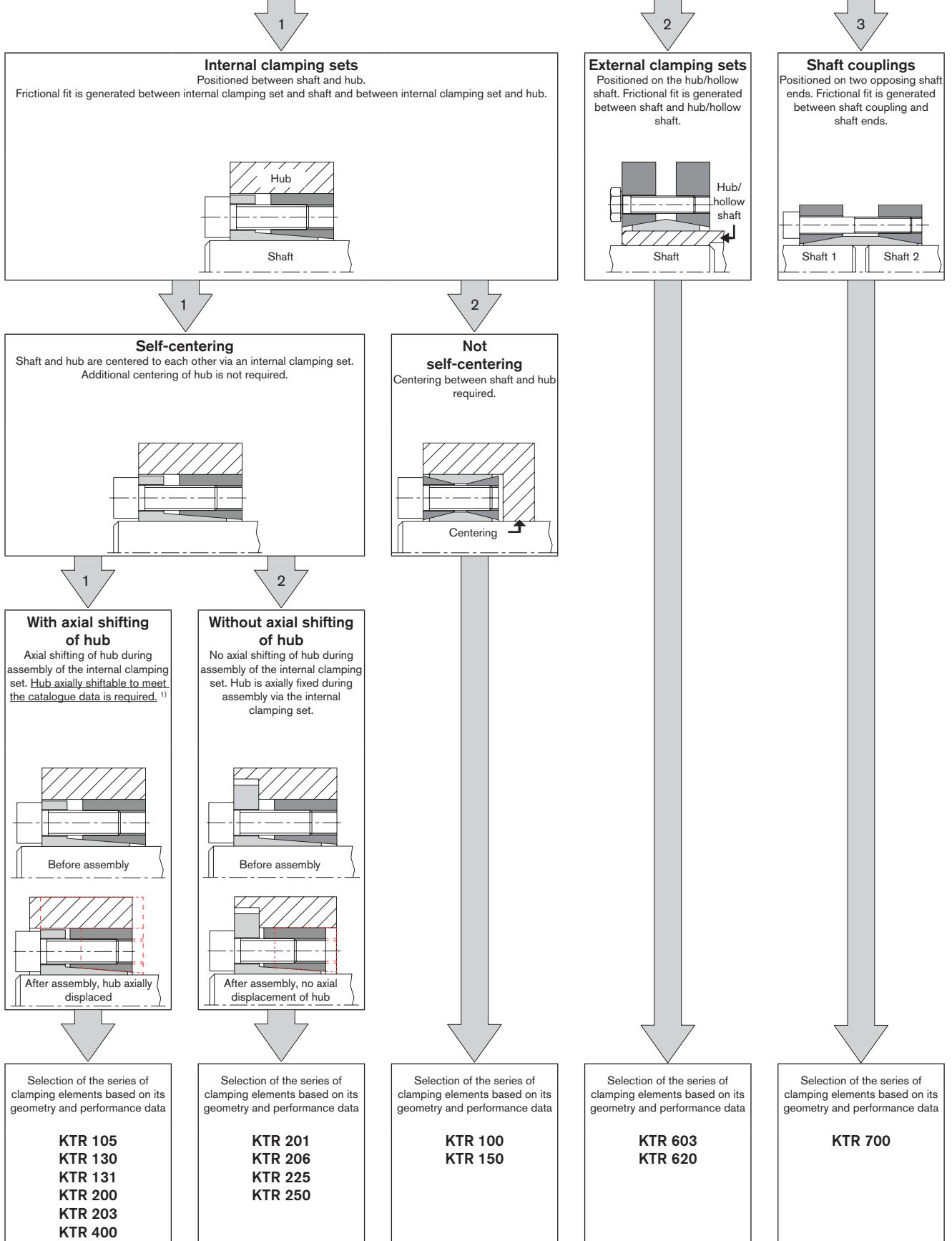

¹⁾ Does not apply for KTR 400

Calculation of hubs

Mounting conditions of clamping elements with value C of hub design

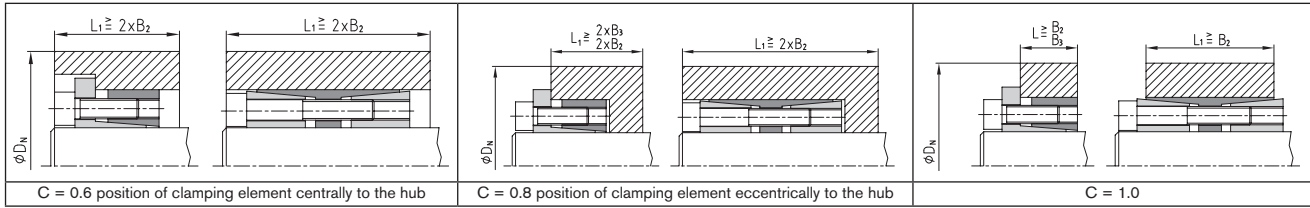

Selection table for the calculation of the external diameter of hub D_N required (correction value x)

Surface pressure between clamping element and hub		Average yield point of material σ 0.2 in N/mm ² (more accurate stiffness figures depending on diameter as specified by the manufacturer)										
		150	180	200	220	250	270	300	350	400	450	600
PN [N/mm ²]	Value C of hub design	Hub materials										
		GJL 200	GJL 250 GE 200	GJL 300 GJMB-350	GE 240 S355J2	GJS 400-15 GE 260 AW-2007	E295 C 35	GJS 500-7 GE 300 S355J2	GJS 600-3 C 45	GJS 700-2 C 60	Q & T steel	Q & T steel
65	C = 0.6	1.30	1.25	1.22	1.20	1.18	1.15	1.13	1.11	1.10	1.09	1.07
	C = 0.8	1.44	1.35	1.30	1.28	1.24	1.22	1.20	1.16	1.14	1.12	1.09
	C = 1.0	1.60	1.45	1.40	1.35	1.30	1.28	1.24	1.20	1.18	1.16	1.12
70	C = 0.6	1.34	1.26	1.24	1.22	1.18	1.16	1.15	1.12	1.11	1.10	1.07
	C = 0.8	1.48	1.38	1.34	1.30	1.25	1.23	1.20	1.18	1.15	1.13	1.10
	C = 1.0	1.65	1.50	1.45	1.40	1.34	1.30	1.26	1.22	1.20	1.17	1.13
75	C = 0.6	1.30	1.28	1.25	1.23	1.20	1.18	1.16	1.14	1.12	1.11	1.08
	C = 0.8	1.52	1.42	1.36	1.32	1.28	1.25	1.22	1.18	1.16	1.14	1.11
	C = 1.0	1.74	1.55	1.48	1.42	1.36	1.33	1.30	1.25	1.20	1.18	1.13
80	C = 0.6	1.39	1.31	1.28	1.25	1.21	1.20	1.18	1.15	1.13	1.11	1.08
	C = 0.8	1.58	1.45	1.39	1.35	1.30	1.27	1.24	1.20	1.18	1.15	1.11
	C = 1.0	1.81	1.61	1.53	1.46	1.39	1.36	1.31	1.26	1.22	1.20	1.14
85	C = 0.6	1.42	1.34	1.30	1.27	1.23	1.21	1.19	1.16	1.14	1.12	1.09
	C = 0.8	1.63	1.49	1.42	1.38	1.32	1.29	1.26	1.22	1.19	1.16	1.12
	C = 1.0	1.90	1.67	1.57	1.50	1.42	1.39	1.34	1.28	1.24	1.21	1.15
90	C = 0.6	1.46	1.36	1.32	1.28	1.25	1.22	1.20	1.17	1.15	1.13	1.09
	C = 0.8	1.69	1.53	1.46	1.40	1.34	1.31	1.28	1.23	1.20	1.18	1.13
	C = 1.0	2.00	1.73	1.62	1.54	1.46	1.41	1.36	1.30	1.26	1.22	1.16
95	C = 0.6	1.49	1.39	1.34	1.30	1.26	1.24	1.21	1.18	1.15	1.14	1.10
	C = 0.8	1.75	1.57	1.49	1.43	1.37	1.34	1.30	1.25	1.21	1.19	1.14
	C = 1.0	2.11	1.80	1.68	1.59	1.49	1.44	1.39	1.32	1.27	1.24	1.17
100	C = 0.6	1.53	1.41	1.36	1.32	1.28	1.25	1.22	1.19	1.16	1.14	1.11
	C = 0.8	1.81	1.61	1.53	1.46	1.39	1.36	1.31	1.26	1.22	1.20	1.14
	C = 1.0	2.24	1.87	1.73	1.63	1.53	1.48	1.41	1.34	1.29	1.25	1.18
105	C = 0.6	1.56	1.44	1.39	1.34	1.29	1.27	1.24	1.20	1.17	1.15	1.11
	C = 0.8	1.88	1.66	1.56	1.50	1.42	1.38	1.33	1.28	1.24	1.21	1.15
	C = 1.0	2.38	1.95	1.79	1.68	1.56	1.51	1.44	1.36	1.31	1.27	1.19
110	C = 0.6	1.60	1.47	1.41	1.36	1.31	1.28	1.25	1.21	1.18	1.16	1.12
	C = 0.8	1.96	1.71	1.60	1.53	1.44	1.40	1.35	1.29	1.25	1.22	1.16
	C = 1.0	2.55	2.04	1.86	1.73	1.60	1.54	1.47	1.38	1.33	1.28	1.20
115	C = 0.6	1.64	1.50	1.43	1.36	1.33	1.30	1.26	1.22	1.19	1.17	1.12
	C = 0.8	2.04	1.76	1.64	1.56	1.47	1.43	1.37	1.31	1.26	1.23	1.17
	C = 1.0	2.75	2.13	1.93	1.79	1.64	1.58	1.50	1.41	1.34	1.30	1.21
120	C = 0.6	1.69	1.53	1.46	1.40	1.34	1.31	1.28	1.23	1.20	1.18	1.13
	C = 0.8	2.13	1.81	1.69	1.60	1.50	1.45	1.39	1.33	1.28	1.24	1.18
	C = 1.0	3.00	2.24	2.00	1.84	1.69	1.61	1.53	1.43	1.36	1.31	1.22
125	C = 0.6	1.73	1.56	1.48	1.43	1.36	1.33	1.29	1.24	1.21	1.18	1.13
	C = 0.8	2.24	1.87	1.73	1.63	1.53	1.48	1.41	1.34	1.29	1.25	1.18
	C = 1.0	3.32	2.35	2.08	1.91	1.73	1.65	1.56	1.45	1.38	1.33	1.24
130	C = 0.6	1.78	1.59	1.51	1.45	1.38	1.35	1.30	1.25	1.22	1.19	1.14
	C = 0.8	2.35	1.93	1.78	1.67	1.56	1.50	1.44	1.36	1.30	1.27	1.19
	C = 1.0	3.74	2.49	2.17	1.97	1.78	1.69	1.59	1.48	1.40	1.35	1.25
135	C = 0.6	1.83	1.62	1.54	1.47	1.40	1.36	1.32	1.27	1.23	1.20	1.15
	C = 0.8	2.48	2.00	1.83	1.71	1.59	1.53	1.46	1.38	1.32	1.28	1.20
	C = 1.0	4.36	2.65	2.27	2.04	1.83	1.73	1.62	1.50	1.42	1.36	1.26
140	C = 0.6	1.88	1.66	1.56	1.50	1.42	1.38	1.33	1.28	1.24	1.21	1.15
	C = 0.8	2.63	2.07	1.88	1.75	1.62	1.55	1.48	1.39	1.33	1.29	1.21
	C = 1.0	5.39	2.83	2.38	2.12	1.88	1.78	1.66	1.53	1.44	1.38	1.27
145	C = 0.6	1.94	1.69	1.59	1.52	1.44	1.40	1.35	1.29	1.25	1.22	1.16
	C = 0.8	2.80	2.15	1.94	1.80	1.65	1.58	1.50	1.41	1.35	1.30	1.22
	C = 1.0	7.68	3.05	2.50	2.21	1.94	1.82	1.69	1.55	1.46	1.40	1.28
150	C = 0.6	2.00	1.73	1.62	1.54	1.46	1.41	1.36	1.30	1.26	1.23	1.16
	C = 0.8	3.00	2.24	2.0	1.84	1.69	1.61	1.53	1.43	1.36	1.31	1.23
	C = 1.0	-	3.32	2.65	2.30	2.00	1.87	1.73	1.58	1.48	1.41	1.29
155	C = 0.6	2.06	1.77	1.65	1.57	1.48	1.43	1.38	1.31	1.27	1.24	1.17
	C = 0.8	3.25	2.33	2.06	1.89	1.72	1.65	1.55	1.45	1.38	1.33	1.23
	C = 1.0	-	3.66	2.80	2.40	2.06	1.92	1.77	1.61	1.51	1.43	1.30
160	C = 0.6	2.13	1.81	1.69	1.60	1.50	1.45	1.39	1.33	1.28	1.24	1.18
	C = 0.8	3.55	2.43	2.13	1.94	1.76	1.67	1.58	1.47	1.39	1.34	1.24
	C = 1.0	-	4.12	3.00	2.52	2.13	1.98	1.81	1.64	1.53	1.45	1.31
165	C = 0.6	2.21	1.86	1.72	1.62	1.52	1.47	1.41	1.34	1.29	1.25	1.18
	C = 0.8	3.96	2.55	2.21	2.00	1.80	1.71	1.60	1.49	1.41	1.35	1.25
	C = 1.0	-	4.80	3.23	2.65	2.21	2.04	1.86	1.67	1.55	1.47	1.33

CLAMPEX® KTR 100

Clamping elements

Not self-centering, suitable for large shaft and hub tolerances



For legend of pictogram please refer to flapper on the cover

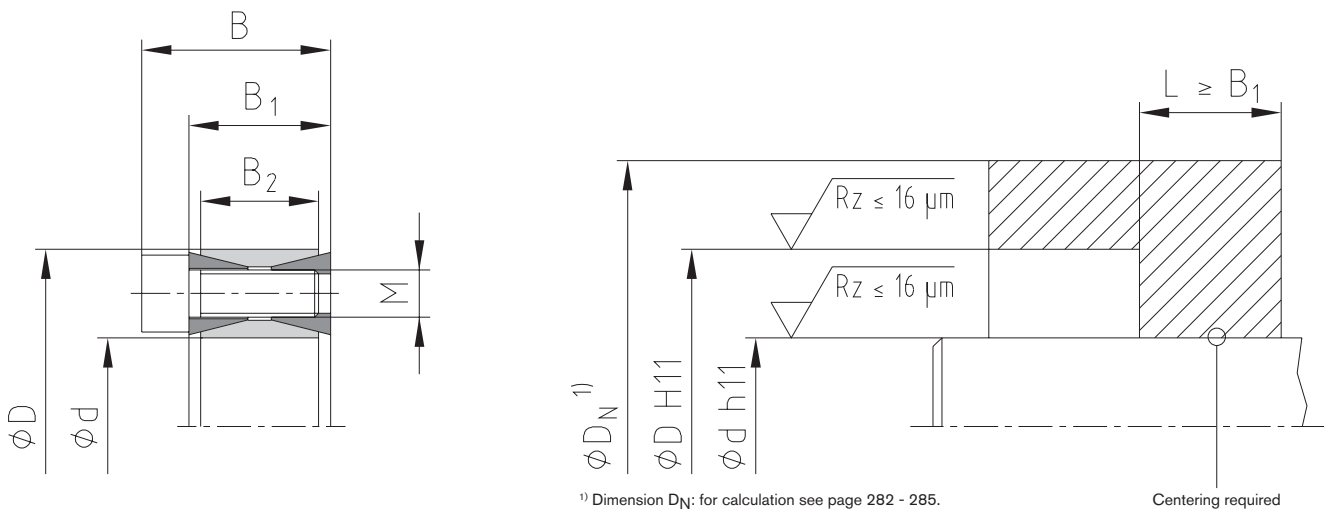

¹⁾ Dimension D_N : for calculation see page 282 - 285.

Example of application of hub design

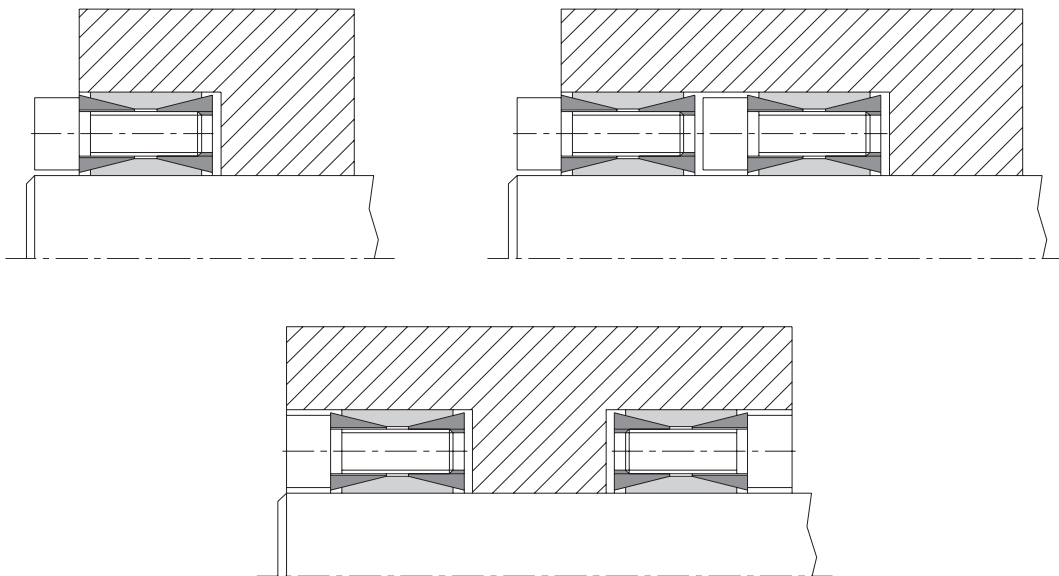

● Sizes of clamping elements available from stock.

¹⁾ These are the maximum screw tightening torques. They can be reduced by a maximum of 40 % of the above-mentioned figures with T , F_{ax} , P_W and P_N decreasing proportionately.

Ordering example:	KTR 100	50	x	80
	Series	Size of internal diameter d		Size of external diameter D

CLAMPEX® – KTR 100

NEW	d x D [mm]	Dimensions [mm]			Clamping screws DIN EN ISO 4762 - 12.9 $\mu_{total}=0.14$				Transmittable torque or axial force		Surface pressure between clamping element		Weight [-kg]	Stock programme
		B	B ₁	B ₂	M	Length	z = number	T _A [Nm] ¹⁾	T [Nm]	F _{ax} [kN]	Shaft P _W [N/mm ²]	Hub P _N [N/mm ²]		
	17 x 47	26	20	17	M6	18	8	16	260	31	281	102	0.2	
	18 x 47	26	20	17	M6	18	8	16	280	31	270	103	0.2	
	19 x 47	26	20	17	M6	18	8	16	290	31	251	101	0.2	●
	20 x 47	26	20	17	M6	18	8	16	310	31	242	103	0.2	●
	22 x 47	26	20	17	M6	18	8	16	340	31	219	103	0.2	●
	24 x 50	26	20	17	M6	18	8	16	370	31	200	96	0.3	●
	25 x 50	26	20	17	M6	18	8	16	390	31	195	97	0.3	●
	28 x 55	26	20	17	M6	18	12	16	650	46	259	132	0.3	●
	30 x 55	26	20	17	M6	18	12	16	700	47	243	132	0.3	●
	32 x 60	26	20	17	M6	18	12	16	750	47	229	122	0.3	●
	35 x 60	26	20	17	M6	18	12	16	820	47	209	122	0.3	●
	38 x 65	26	20	17	M6	18	15	16	1100	58	238	139	0.4	●
	40 x 65	26	20	17	M6	18	15	16	1170	59	228	140	0.3	●
	42 x 75	32	24	20	M8	22	12	40	1670	80	251	141	0.6	●
	45 x 75	32	24	20	M8	22	12	40	1790	80	234	141	0.5	●
	48 x 80	32	24	20	M8	22	12	40	1900	79	219	131	0.6	●
	50 x 80	32	24	20	M8	22	12	40	1990	80	211	132	0.6	●
	55 x 85	32	24	20	M8	22	15	40	2740	100	240	155	0.6	●
	60 x 90	32	24	20	M8	22	15	40	2990	100	220	147	0.7	●
	65 x 95	32	24	20	M8	22	15	40	3240	100	203	139	0.8	●
	70 x 110	38	28	24	M10	25	15	78	5550	159	250	159	1.3	●
	75 x 115	38	28	24	M10	25	15	78	5950	159	234	152	1.2	●
	80 x 120	38	28	24	M10	25	15	78	6350	159	219	146	1.4	●
	85 x 125	38	28	24	M10	25	15	78	6740	159	206	140	1.4	●
	90 x 130	38	28	24	M10	25	15	78	7140	159	195	135	1.5	●
	95 x 135	38	28	24	M10	25	18	78	9000	189	220	155	1.6	●
	100 x 145	44	32	26	M12	30	15	135	11600	232	237	163	2.2	●
	110 x 155	44	32	26	M12	30	15	135	12750	232	215	153	2.3	●
	120 x 165	44	32	26	M12	30	16	135	14800	247	210	153	2.4	●
	130 x 180	50	38	34	M12	30	20	135	20150	310	186	134	3.5	●
	140 x 190	50	38	34	M12	30	22	135	23850	341	190	140	3.8	●
	150 x 200	50	38	34	M12	30	24	135	27850	371	193	145	4.0	●
	160 x 210	50	38	34	M12	30	26	135	32200	403	196	150	4.4	●
	170 x 225	58	44	38	M14	45	22	215	40300	474	195	147	5.7	●
	180 x 235	58	44	38	M14	45	24	215	46600	518	201	154	6.0	●
	190 x 250	66	52	46	M14	45	28	215	57300	603	183	139	8.0	●
	200 x 260	66	52	46	M14	45	30	215	71000	710	205	157	8.2	●
	220 x 285	72	56	50	M16	50	26	335	93200	847	204	158	11.0	●
	240 x 305	72	56	50	M16	50	30	335	117300	978	216	170	12.2	●
	260 x 325	72	56	50	M16	50	34	335	144000	1108	226	181	13.2	●
	280 x 355	84	66	60	M18	60	32	465	177700	1269	200	158	19.2	●
	300 x 375	84	66	60	M18	60	36	465	214100	1427	210	168	20.5	●
	320 x 405	98	78	72	M20	70	36	660	295800	1849	213	168	29.6	●
	340 x 425	98	78	72	M20	70	36	660	314300	1849	200	160	31.1	●
	360 x 455	112	90	84	M22	80	36	900	413300	2296	201	159	42.2	●
	380 x 475	112	90	84	M22	80	36	900	436300	2296	191	153	44.0	●
	400 x 495	112	90	84	M22	80	36	900	459300	2297	181	147	46.0	●
	420 x 515	112	90	84	M22	80	40	900	535800	2551	192	156	50.0	●
	440 x 545	130	102	96	M24	90	40	1130	647600	2944	185	149	64.6	●
	460 x 565	130	102	96	M24	90	40	1130	677000	2943	177	144	67.4	●
	480 x 585	130	102	96	M24	90	42	1130	741800	3091	178	146	71.0	●
	500 x 605	130	102	96	M24	90	44	1130	809500	3238	179	148	72.6	●
	520 x 630	130	102	96	M24	90	45	1130	861000	3312	176	145	80	●
	540 x 650	130	102	96	M24	90	45	1130	894000	3311	169	141	82	●
	560 x 670	130	102	96	M24	90	48	1130	989000	3532	174	146	85	●
	580 x 690	130	102	96	M24	90	50	1130	1067000	3679	175	147	88	●
	600 x 710	130	102	96	M24	90	50	1130	1103800	3679	169	143	91	●
NEW	620 x 730	130	102	96	M24	90	52	1130	1186200	3826	171	145	93	●
NEW	640 x 750	130	102	96	M24	90	54	1130	1271600	3974	172	146	96	●
NEW	660 x 770	130	102	96	M24	90	56	1130	1359900	4121	173	148	99	●
NEW	680 x 790	130	102	96	M24	90	56	1130	1401100	4121	167	144	102	●
NEW	700 x 810	130	102	96	M24	90	60	1130	1545400	4415	174	151	104	●
NEW	720 x 830	130	102	96	M24	90	60	1130	1589500	4415	169	147	107	●
NEW	740 x 850	130	102	96	M24	90	62	1130	1688100	4562	170	148	110	●
NEW	760 x 870	130	102	96	M24	90	64	1130	1789700	4710	171	150	113	●
NEW	780 x 890	130	102	96	M24	90	65	1130	1865500	4783	169	149	116	●
NEW	800 x 910	130	102	96	M24	90	66	1130	1942700	4857	168	147	118	●
NEW	820 x 930	130	102	96	M24	90	68	1130	2051600	5004	169	149	121	●
NEW	840 x 950	130	102	96	M24	90	70	1130	2163500	5151	169	150	124	●
NEW	860 x 970	130	102	96	M24	90	72	1130	2278300	5298	170	151	127	●
NEW	880 x 990	130	102	96	M24	90	74	1130	2396000	5445	171	152	129	●
NEW	900 x 1010	130	102	96	M24	90	75	1130	2483600	5519	169	151	132	●
NEW	920 x 1030	130	102	96	M24	90	76	1130	2572600	5593	168	150	135	●
NEW	940 x 1050	130	102	96	M24	90	78	1130	2697700	5740	169	151	138	●
NEW	960 x 1070	130	102	96	M24	90	80	1130	2825800	5887	169	152	140	●
NEW	980 x 1090	130	102	96	M24	90	81	1130	2920700	5961	168	151	143	●
NEW	1000 x 1110	130	102	96	M24	90	82	1130	3017100	6034	167	150	146	●

CLAMPEX®

Clamping nuts

KTR Precision joints

Clamping sets

CLAMPEX® KTR 105

Clamping elements

Self-centering clamping element in a compact design

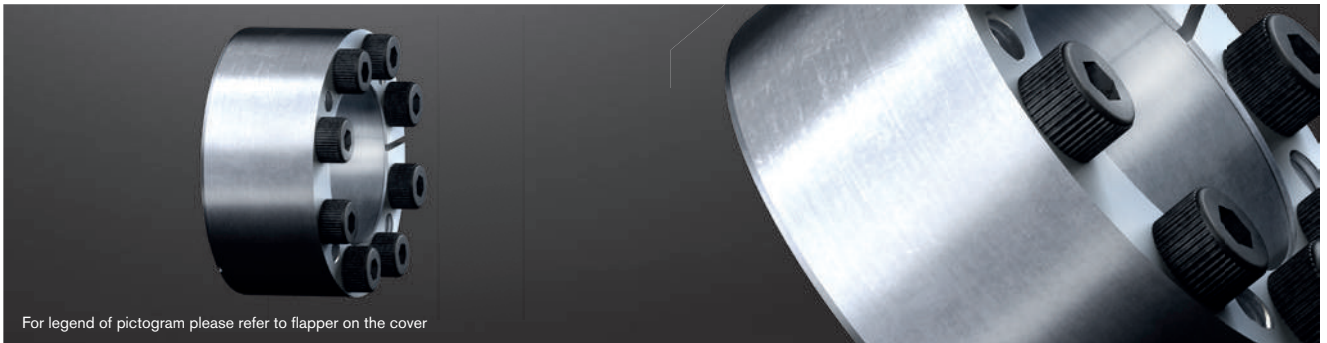

For legend of pictogram please refer to flapper on the cover

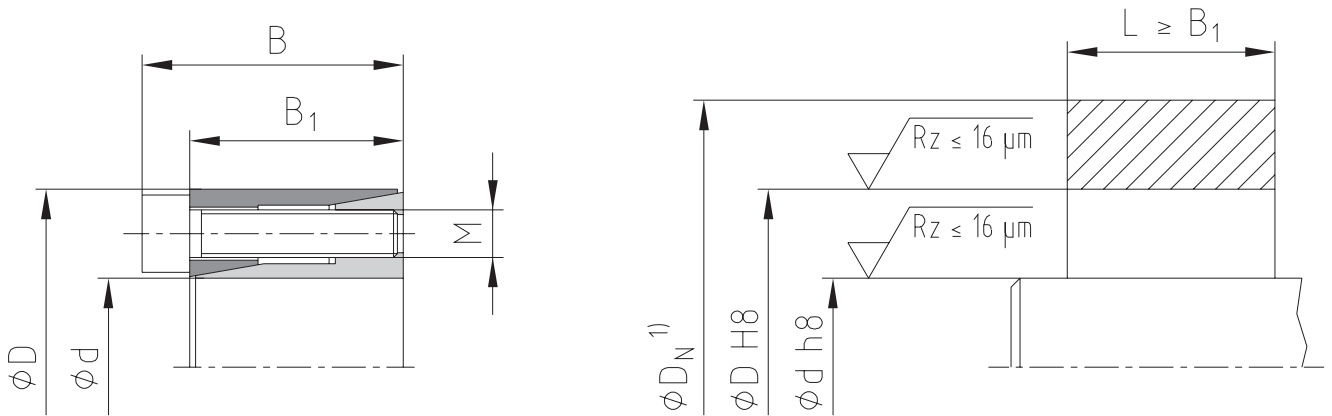
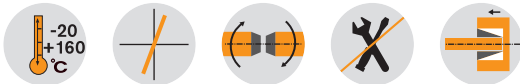

¹⁾ Dimension D_N : for calculation see page 282 - 285.

Example of application of hub design

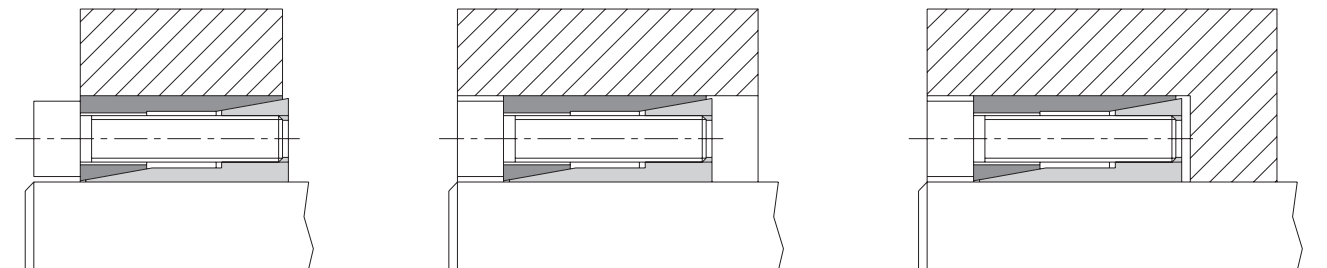

Ordering example:	KTR 105	8	x	18
	Series	Size of internal diameter d		Size of external diameter D

CLAMPEX® – KTR 105													
d x D [mm]	Dimensions [mm]		Clamping screws DIN EN ISO 4762 - 12.9 $\mu_{total}=0.14$				Transmittable torque or axial force			Surface pressure between clamping element		Weight [-kg]	Stock programme
	B	B1	M	Length	z = number	T _A [Nm] ¹⁾	T [Nm]	F _{ax} [kN]	Shaft P _W [N/mm ²]	Hub P _N [N/mm ²]			
5 x 16	13.5	11	M2.5	10	3	1.2	5	2	177	55	0.01	●	
6 x 16	13.5	11	M2.5	10	3	1.2	6	2	147	55	0.01	●	
6.35 x 16	13.5	11	M2.5	10	3	1.2	6	2	132	52	0.01	●	
7 x 17	13.5	11	M2.5	10	3	1.2	8	2	144	59	0.01	●	
8 x 18	13.5	11	M2.5	10	3	1.2	10	3	138	61	0.02	●	
9 x 20	15.5	13	M2.5	12	4	1.2	15	3	140	63	0.02	●	
9.53 x 20	15.5	13	M2.5	12	4	1.2	15	3	125	60	0.02	●	
10 x 20	15.5	13	M2.5	12	4	1.2	15	3	114	57	0.02	●	
11 x 22	15.5	13	M2.5	12	4	1.2	18	3	113	56	0.02	●	
12 x 22	15.5	13	M2.5	12	4	1.2	20	3	105	57	0.02	●	
14 x 26	20	17	M3	16	4	2.1	35	5	105	57	0.04	●	
15 x 28	20	17	M3	16	4	2.1	40	5	94	51	0.04	●	
16 x 32	21	17	M4	16	4	4.9	70	9	132	66	0.07	●	
17 x 35	25	21	M4	20	4	4.9	75	9	125	61	0.09	●	
18 x 35	25	21	M4	20	4	4.9	80	9	119	61	0.09	●	
19 x 35	25	21	M4	20	4	4.9	85	9	114	62	0.08	●	
20 x 38	26	21	M5	20	4	9.7	150	15	153	81	0.1	●	
22 x 40	26	21	M5	20	4	9.7	160	15	135	74	0.1	●	
24 x 47	32	26	M6	25	4	16.5	250	21	154	78	0.2	●	
25 x 47	32	26	M6	25	4	16.5	260	21	147	78	0.2	●	
28 x 50	32	26	M6	25	6	16.5	440	31	198	111	0.2	●	
30 x 55	32	26	M6	25	6	16.5	470	31	185	101	0.3	●	
32 x 55	32	26	M6	25	6	16.5	500	31	173	100	0.25	●	
35 x 60	37	31	M6	30	8	16.5	730	42	166	97	0.35	●	
38 x 65	37	31	M6	30	8	16.5	800	42	155	90	0.4	●	
40 x 65	37	31	M6	30	8	16.5	840	42	147	90	0.4	●	
42 x 75	44	36	M8	35	6	40	911	43	125	70	0.7	●	
45 x 75	44	36	M8	35	8	40	1300	58	155	93	0.6	●	
48 x 80	44	36	M8	35	8	40	1824	76	191	115	0.7	●	
50 x 80	44	36	M8	35	8	40	1900	76	183	115	0.7	●	

● Sizes of clamping elements available from stock.

¹⁾ These are the maximum screw tightening torques. They can be reduced by a maximum of 40 % of the above-mentioned figures with T, F_{ax}, P_W and P_N decreasing proportionately.

CLAMPEX® KTR 130 and KTR 131

Clamping elements

Self-centering clamping elements with a central clamping nut for easy assembly/disassembly

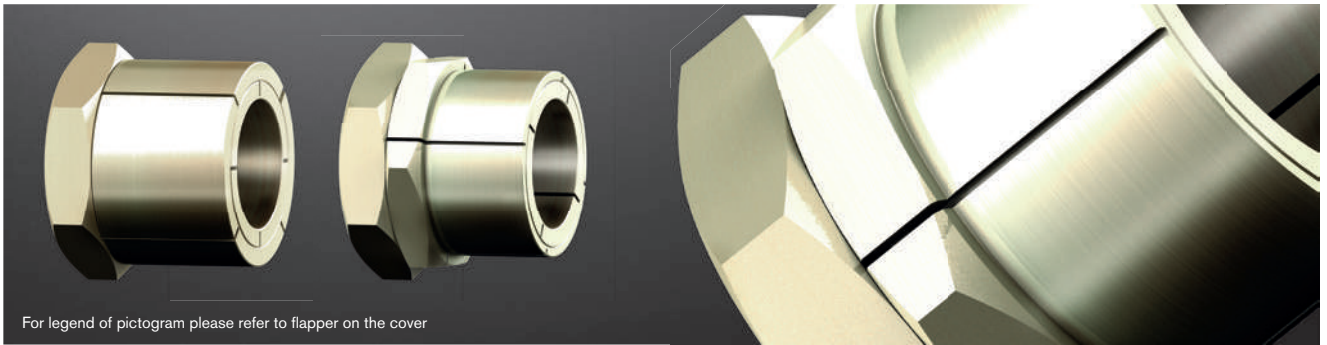

For legend of pictogram please refer to flapper on the cover

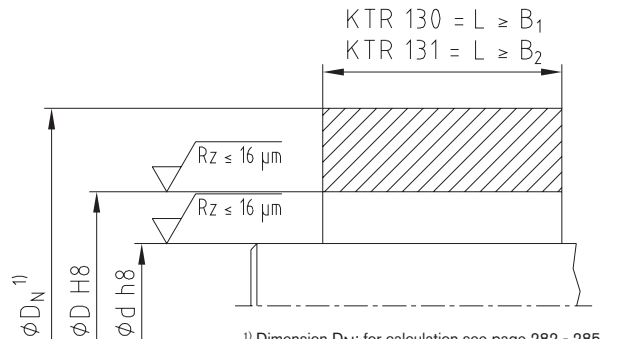
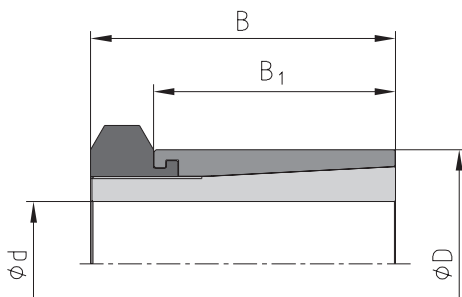
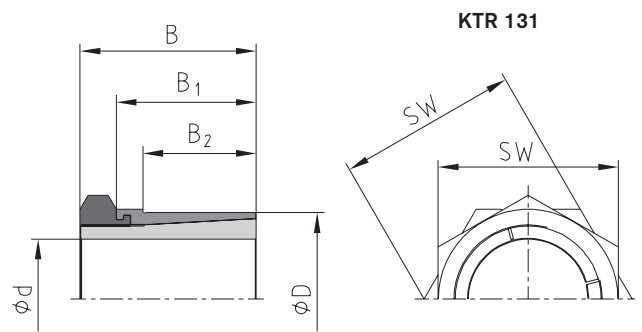
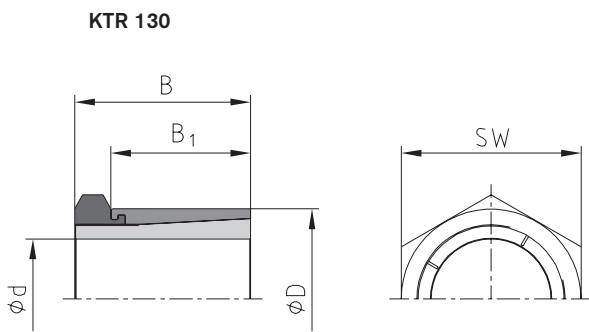

Example of application of hub design

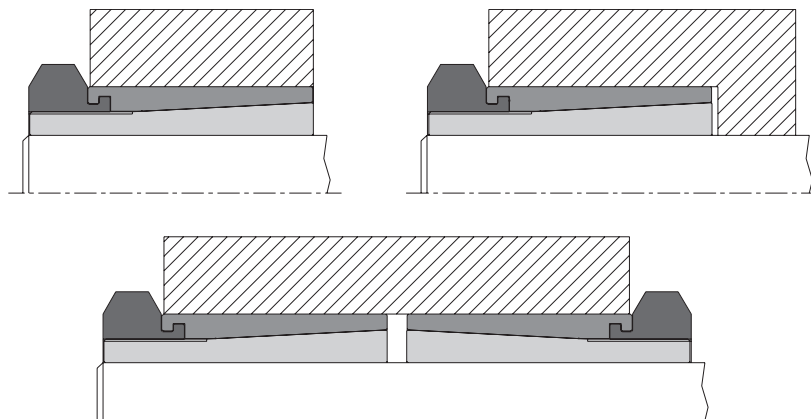

Ordering example:	KTR 130	18	x	35
	Series	Size of internal diameter d		Size of external diameter D

CLAMPEX® – KTR 130											
d x D [mm]	Dimensions [mm]		Hexagon nut		Transmittable torque or axial force			Surface pressure between clamping element		Weight [-kg]	Stock programme
	B	B ₁	Width across flats SW	T _A [Nm] ¹⁾	T [Nm]	F _{ax} [kN]	Shaft P _W [N/mm ²]	Hub P _N [N/mm ²]			
5 x 14	19	15	14	10	10.1	4.0	264	96	0.02	●	
6 x 14	19	15	14	10	12.1	4.0	220	96	0.02	●	
8 x 16	22	17	17	17	23.4	5.8	179	91	0.02	●	
9 x 20	24	19	22	35	43.2	9.7	248	112	0.04	●	
10 x 20	24	19	22	35	48.6	9.7	223	112	0.05	●	
12 x 22	24	19	22	44	65.3	10.9	206	117	0.05	●	
14 x 26	28	22	27	65	93.0	13.3	178	99	0.08	●	
15 x 26	28	22	27	65	99.0	13.3	166	99	0.08	●	
16 x 26	28	22	27	65	106	13.3	156	99	0.07	●	
18 x 35	36	27	36	161	223	24.8	224	125	0.2	●	
19 x 35	36	27	36	161	235	24.8	212	125	0.2	●	
20 x 35	36	27	36	161	248	24.8	201	125	0.2	●	
22 x 42	41	30	46	250	349	31.8	197	110	0.3	●	
24 x 42	41	30	46	250	381	31.8	180	110	0.3	●	
25 x 42	41	30	46	250	397	31.8	173	110	0.3	●	
30 x 47	44	33	50	355	605	40.4	162	110	0.4	●	
32 x 55	51	38	55	490	764	47.8	166	102	0.6	●	
35 x 55	51	38	55	490	836	47.8	151	102	0.6	●	
40 x 62	58	43	65	800	1329	66.5	152	98	0.8	●	
45 x 65	63	48	65	900	1605	71.0	142	98	0.9	●	
48 x 75	73	58	75	1290	2227	92.0	121	77	1.5	●	
50 x 75	73	58	75	1290	2320	92.0	116	77	1.4	●	

● Sizes of clamping elements available from stock.

¹⁾ These are the maximum screw tightening torques. They can be reduced by a maximum of 40 % of the above-mentioned figures with T, F_{ax}, P_W and P_N decreasing proportionately.

CLAMPEX® – KTR 131											
d x D [mm]	Dimensions [mm]			Hexagon nut/ counter hexagon nut		Transmittable torque or axial force		Surface pressure between clamping element		Weight [-kg]	Stock programme
	B	B ₁	B ₂	Width across flats SW	T _A [Nm] ¹⁾	T [Nm]	F _{ax} [kN]	Shaft P _W [N/mm ²]	Hub P _N [N/mm ²]		
5 x 12	19	15	9	14	10	10.1	4.0	264	119	0.02	●
6 x 12	19	15	9	14	10	12.1	4.0	220	119	0.02	●
8 x 14	22	17	11	17	17	23.4	5.8	179	121	0.02	●
10 x 18	24	19	12	22	35	48.6	9.7	221	127	0.04	●
12 x 20	24	19	12	22	44	65.3	10.9	206	128	0.04	●
14 x 24	28	22	15	27	65	93.0	13.3	178	107	0.08	●
15 x 24	28	22	15	27	65	99.0	13.3	166	107	0.07	●
16 x 24	28	22	15	27	65	106	13.3	156	107	0.07	●
18 x 30	36	27	17	36	161	223	24.8	224	145	0.2	●
19 x 30	36	27	17	36	161	235	24.8	212	145	0.2	●
20 x 30	36	27	17	36	161	248	24.8	201	145	0.15	●
22 x 38	41	30	20	46	250	349	31.8	197	122	0.35	●
24 x 38	41	30	20	46	250	381	31.8	180	122	0.3	●
25 x 38	41	30	20	46	250	397	31.8	173	122	0.3	●
30 x 42	44	33	23	50	355	605	40.4	162	123	0.35	●
32 x 50	51	38	28	55	490	764	47.8	166	112	0.55	●
35 x 50	51	38	28	55	490	836	47.8	151	112	0.5	●

● Sizes of clamping elements available from stock.

¹⁾ These are the maximum screw tightening torques. They can be reduced by a maximum of 40 % of the above-mentioned figures with T, F_{ax}, P_W and P_N decreasing proportionately.

CLAMPEX® KTR 150

Clamping elements

Not self-centering clamping element with minimum dimensions



For legend of pictogram please refer to flapper on the cover

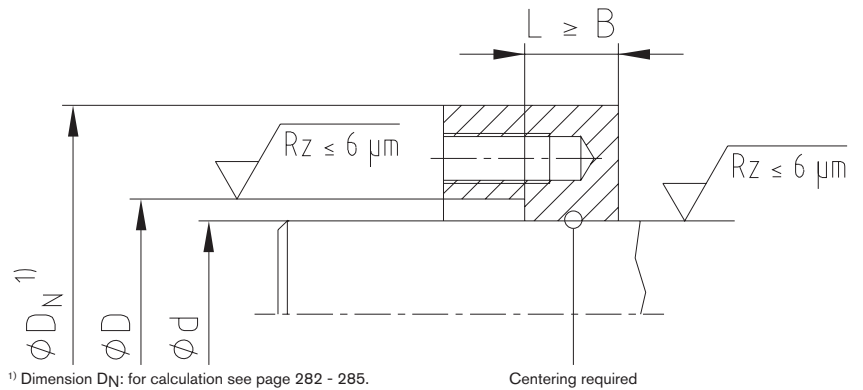
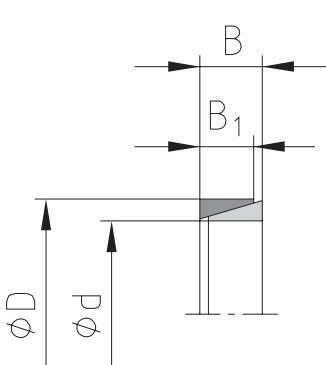
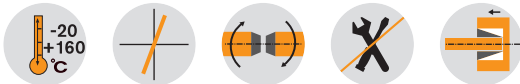

¹⁾ Dimension DN: for calculation see page 282 - 285.

Tolerances for d and D

$$d \leq 38 \text{ mm} = d \text{ h6/D H7}$$

$$d > 38 \text{ mm} = d \text{ h8/D H8}$$

Example of application of hub design

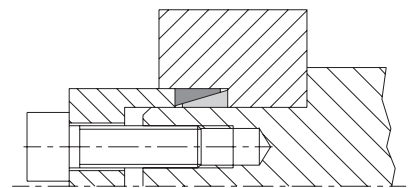
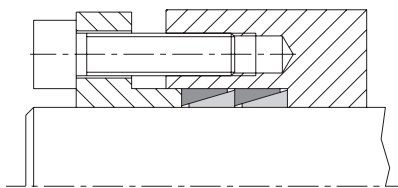
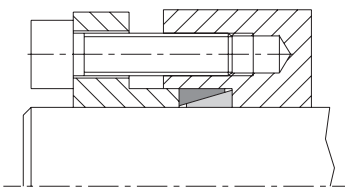

Up to four clamping elements can be installed in a series.

The torques rise as follows:

- 1 clamping element $T = T_{\text{catalogue}} \times 1.00$
- 2 clamping elements $T = T_{\text{catalogue}} \times 1.55$
- 3 clamping elements $T = T_{\text{catalogue}} \times 1.85$
- 4 clamping elements $T = T_{\text{catalogue}} \times 2.02$

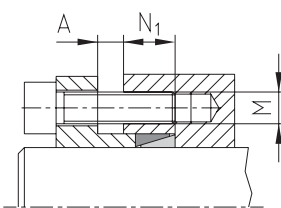

Pressure flanges

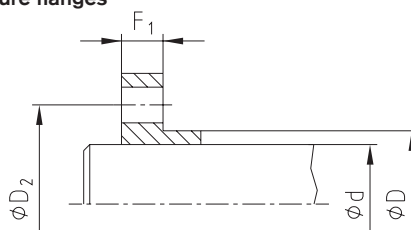

Dimensions of pressure flanges recommended:

- $N_1 \text{ [mm]} \geq 1.5 \cdot B$
- $D_2 \text{ [mm]} = D + 12 + M$
- $F_1 \text{ [mm]} = M \cdot 1.3$ (with screws 8.8)
- $F_1 \text{ [mm]} = M \cdot 1.8$ (with screws 10.9/12.9)

Ordering example:	KTR 150	60	x	68
	Series	Size of internal diameter d		Size of external diameter D

CLAMPEX® – KTR 150

d x D [mm]	Dimensions [mm]		Distance dimension A [mm]				Clamping force required for clamping screws $\mu_{total}=0.14$			Transmittable torque or axial force		Surface pressure between clamping element		Weight [-kg]	Stock programme
	B	B ₁	Clamping elements				P _O [kN]	P _S [kN]	P _A = P _O + P _S [kN]	T [Nm]	F _{ax} [kN]	Shaft P _W [N/mm ²]	Hub P _N [N/mm ²]		
			1	2	3	4									
6 x 9	4.5	3.7	3	3	3	4	0**	3	3	2	0.6	80	53	0.0015	●
7 x 10	4.5	3.7	3	3	3	4	0**	5	5	4	1	117	82	0.0014	●
8 x 11	4.5	3.7	3	3	3	4	0**	6	6	5	1	112	81	0.0015	●
9 x 12	4.5	3.7	3	3	3	4	8	8	16	8	1	142	106	0.0017	●
10 x 13	4.5	3.7	3	3	3	4	7	9	16	10	2	143	110	0.0018	●
12 x 15	4.5	3.7	3	3	3	4	7	8	15	11	1	110	88	0.0022	●
13 x 16	4.5	3.7	3	3	3	4	6	10	16	13	2	110	90	0.0023	●
14 x 18	6.3	5.3	3	4	4	5	11	15	26	22	3	112	87	0.0049	●
15 x 19	6.3	5.3	3	4	4	5	11	15	26	25	3	111	88	0.0053	●
16 x 20	6.3	5.3	3	4	4	5	10	15	25	26	3	102	81	0.0055	●
17 x 21	6.3	5.3	3	4	4	5	10	16	26	30	3	104	84	0.0058	●
18 x 22	6.3	5.3	3	4	4	5	9	17	26	33	3	102	83	0.0061	●
19 x 24	6.3	5.3	3	4	4	5	13	19	32	40	4	111	88	0.0078	●
20 x 25	6.3	5.3	3	4	4	5	12	20	32	44	4	110	88	0.0082	●
22 x 26	6.3	5.3	3	4	4	5	9	21	30	50	4	103	87	0.0072	●
24 x 28	6.3	5.3	3	4	4	5	8	26	34	68	5	118	101	0.0079	●
25 x 30	6.3	5.3	3	4	4	5	10	27	37	75	6	120	100	0.01	●
28 x 32	6.3	5.3	3	4	4	5	7	30	37	90	6	115	101	0.009	●
30 x 35	6.3	5.3	3	4	4	5	8	31	39	100	6	111	95	0.012	●
32 x 36	6.3	5.3	3	4	4	5	8	34	42	120	7	117	104	0.01	●
35 x 40	7	6.0	3	4	4	5	13	42	55	160	9	115	101	0.02	●
36 x 42	7	6.0	4	5	5	6	15	43	58	170	9	116	99	0.02	●
38 x 44	7	6.0	4	5	5	6	14	46	60	190	10	116	100	0.02	●
40 x 45	8	6.6	4	5	5	6	14	53	67	230	11	116	103	0.02	●
42 x 48	8	6.6	4	5	5	6	16	57	73	260	12	118	104	0.03	●
45 x 52	10	8.6	4	5	5	6	26	80	106	390	17	119	103	0.05	●
48 x 55	10	8.6	4	5	5	6	25	82	107	430	17	115	100	0.05	●
50 x 57	10	8.6	4	5	5	6	24	86	110	470	18	116	102	0.05	●
55 x 62	10	8.6	4	5	5	6	22	97	119	580	21	118	105	0.05	●
56 x 64	12	10.4	4	5	5	6	29	122	151	740	26	120	105	0.07	●
60 x 68	12	10.4	4	5	6	7	27	129	156	840	28	119	105	0.07	●
63 x 71	12	10.4	4	5	6	7	26	134	160	920	29	118	105	0.08	●
65 x 73	12	10.4	4	5	6	7	25	142	167	1000	30	121	108	0.08	●
70 x 79	14	12.2	4	5	6	7	31	171	202	1300	37	115	102	0.11	●
71 x 80	14	12.2	4	5	6	7	31	181	212	1400	39	121	107	0.11	●
75 x 84	14	12.2	4	5	6	7	34	184	218	1500	40	116	104	0.12	●
80 x 91	17	15.0	5	6	7	8	48	241	289	2100	52	116	102	0.12	●
85 x 96	17	15.0	5	6	7	8	45	260	305	2400	56	117	104	0.2	●
90 x 101	17	15.0	5	6	7	8	43	276	319	2700	60	118	105	0.2	●
95 x 106	17	15.0	5	6	8	9	41	290	331	3000	63	118	105	0.22	●
100 x 114	21	18.7	5	6	8	9	61	386	447	4200	84	119	105	0.4	●
110 x 124	21	18.7	5	6	8	9	65	393	458	4700	85	110	98	0.4	●
120 x 134	21	18.7	5	6	8	9	60	391	451	5100	85	100	90	0.5	●
130 x 148	28	25.3	6	7	9	11	96	573	669	8100	124	101	88	0.85	●
140 x 158	28	25.3	6	7	9	11	89	618	707	9400	134	101	89	0.91	●
150 x 168	28	25.3	6	7	9	11	84	674	758	11000	146	103	92	0.97	●
160 x 178	28	25.3	6	7	9	11	79	833	912	14500	181	119	107	1.02	●
170 x 191	33	30.0	7	8	10	12	118	1054	1172	19500	229	119	106	1.5	●
180 x 201	33	30.0	7	8	10	12	112	1082	1194	21200	235	116	104	1.6	●
190 x 211	33	30.0	7	9	10	12	106	1166	1272	24100	253	118	106	1.7	●
200 x 224	38	34.5	7	9	11	13	133	1425	1558	31000	310	119	106	2.3	●
210 x 234	38	34.5	7	9	11	13	127	1532	1659	35000	333	122	110	2.5	●
220 x 244	38	34.5	7	9	11	13	122	1587	1709	38000	345	121	109	2.5	●
230 x 257	43	39.5	7	9	12	14	165	1579	1744	39500	343	100	90	3.4	●
240 x 267	43	39.5	7	9	12	14	158	1801	1959	47000	391	110	99	3.5	●
250 x 280	48	44.0	8	10	13	16	188	1912	2100	52000	416	100	90	4.7	●
260 x 290	48	44.0	8	10	13	16	181	1997	2178	56500	434	101	90	4.8	●
270 x 300	48	44.0	8	10	13	16	174	2077	2251	61000	451	101	91	4.9	●
280 x 313	53	49.0	9	11	14	17	205	2381	2586	72500	517	100	90	6.3	●
290 x 323	53	49.0	9	11	14	17	221	2457	2678	77500	534	100	90	6.5	●
300 x 333	53	49.0	9	11	14	17	214	2544	2758	83000	553	100	90	6.7	●
320 x 360	65	59.0	10	15	20	25	291	3275	3566	114000	712	100	89	10.9	●
340 x 380	65	59.0	10	15	20	25	275	3474	3749	128500	755	100	89	11.5	●
360 x 400	65	59.0	10	15	20	25	261	3677	3938	144000	800	100	90	12.2	●
380 x 420	65	59.0	10	15	20	25	269	3870	4139	160000	842	100	90	12.8	●
400 x 440	65	59.0	10	15	20	25	256	4091	4347	178000	890	100	91	13.5	●
420 x 460	65	59.0	10	15	20	25	244	4290	4534	196000	933	100	91	14.1	●
440 x 480	65	59.0	10	15	20	25	234	4492	4726	215000	977	100	92	14.7	●

● Sizes of clamping elements available from stock.

** Slotted type

Other sizes on request.

P_A = Total force

P_O = Setting force

P_S = Clamping force

For continuously updated data please refer to our online catalogue at www.ktr.com

CLAMPEX®

Clamping nuts

KTR Precision joints

Clamping sets

CLAMPEX® KTR 200 and KTR 201 Clamping elements

Self-centering clamping elements with a wide range of applications

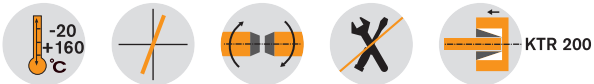
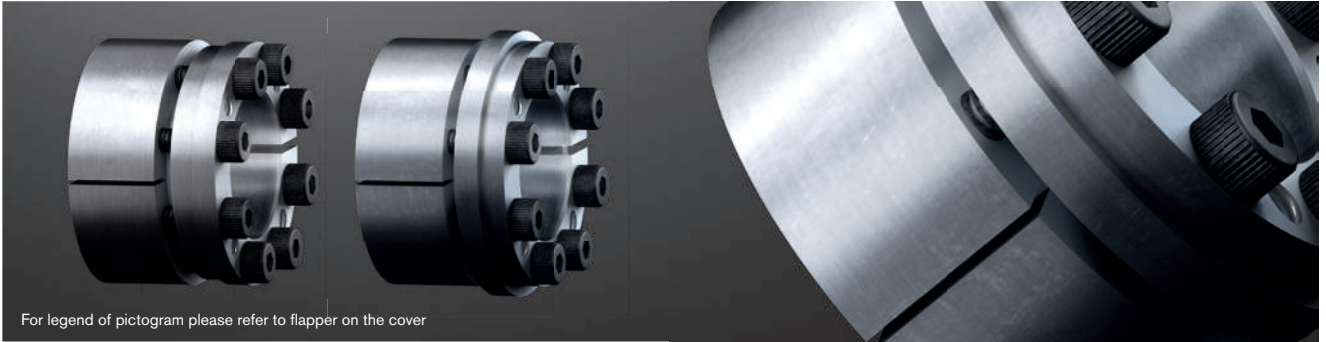

KTR 200

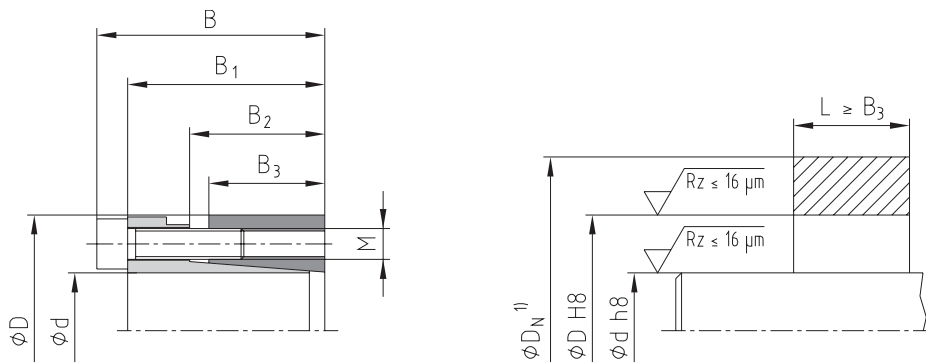

¹⁾ Dimension D_N : for calculation see page 282 - 285.

Example of application of hub design

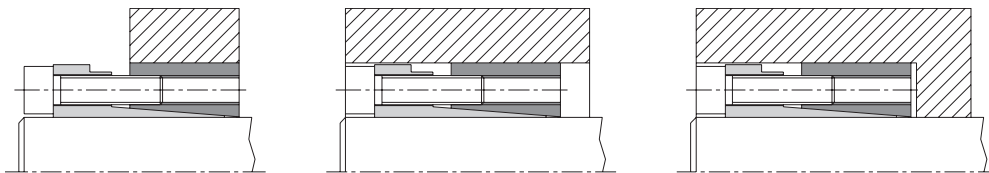

KTR 201

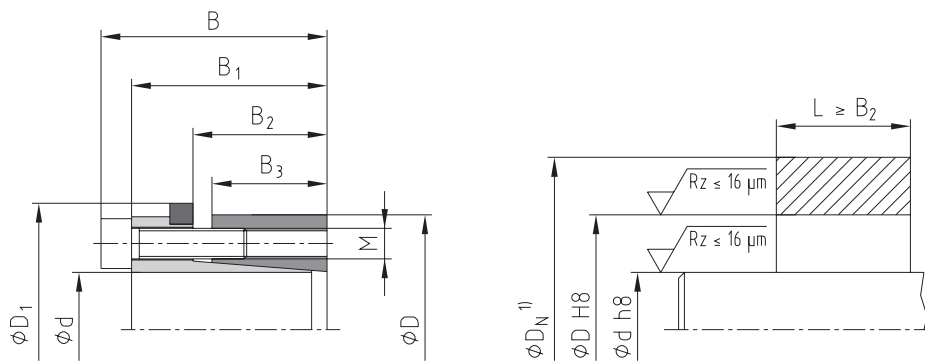

¹⁾ Dimension D_N : for calculation see page 282 - 285.

Example of application of hub design

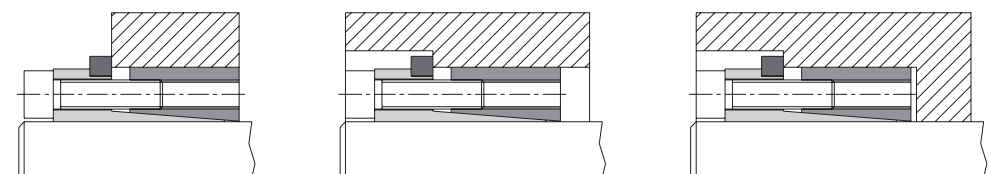

**Ordering
example:**

KTR 200	40	x	65
Series	Size of internal diameter d		Size of external diameter D

CLAMPEX® – KTR 200 and KTR 201

d x D [mm]	Dimensions [mm]					Clamping screws DIN EN ISO 4762 - 12.9 $\mu_{total}=0.14$					KTR 200				KTR 201							
											Transmittable torque or axial force		Surface pressure between clamping element		Weight [-kg]	Stock programme	Transmittable torque or axial force		Surface pressure between clamping element		Weight [-kg]	Stock programme
	T [Nm]	F _{ax} [kN]	Shaft P _W [N/mm ²]	Hub P _N [N/mm ²]	T [Nm]	F _{ax} [kN]	Shaft P _W [N/mm ²]	Hub P _N [N/mm ²]														
20 x 47	48	42	31	26	53	M6	25	6	17	17	530	53	270	115	0.4	●	320	32	163	69	0.4	●
22 x 47	48	42	31	26	53	M6	25	6	17	17	580	53	245	114	0.4	●	360	33	152	71	0.4	●
24 x 50	48	42	31	26	56	M6	25	6	17	17	630	53	223	107	0.4	●	390	33	138	66	0.4	●
25 x 50	48	42	31	26	56	M6	25	6	17	17	660	53	215	108	0.4	●	400	32	131	65	0.4	●
28 x 55	48	42	31	26	61	M6	25	6	17	17	740	53	193	98	0.5	●	450	32	117	60	0.5	●
30 x 55	48	42	31	26	61	M6	25	6	17	17	790	53	179	98	0.5	●	490	33	111	61	0.5	●
32 x 60	48	42	31	26	66	M6	25	8	17	17	1150	72	229	122	0.6	●	690	43	137	73	0.6	●
35 x 60	48	42	31	26	66	M6	25	8	17	17	1300	74	217	126	0.6	●	750	43	125	73	0.5	●
38 x 65	48	42	31	26	71	M6	25	8	17	17	1300	68	184	107	0.6	●	820	43	116	68	0.6	●
40 x 65	48	42	31	26	71	M6	25	8	17	17	1400	70	179	110	0.6	●	860	43	110	67	0.6	●
42 x 75	59	51	35	30	81	M8	30	6	41	41	2000	95	200	112	1.0	●	1300	62	130	73	1.0	●
45 x 75	59	51	35	30	81	M8	30	6	41	41	2200	98	192	115	1.0	●	1400	62	122	73	1.0	●
48 x 80	59	51	35	30	86	M8	30	8	41	41	3200	133	246	147	1.1	●	1900	79	146	87	1.1	●
50 x 80	59	51	35	30	86	M8	30	8	41	41	3300	132	233	146	1.1	●	2000	80	141	88	1.1	●
55 x 85	59	51	35	30	91	M8	30	8	41	41	3600	131	210	136	1.2	●	2200	80	129	83	1.2	●
60 x 90	59	51	35	30	96	M8	30	8	41	41	3900	130	192	128	1.2	●	2400	80	118	79	1.2	●
65 x 95	59	51	35	30	101	M8	30	8	41	41	4300	132	180	123	1.3	●	2600	80	109	74	1.3	●
70 x 110	71	61	46	40	119	M10	30	8	83	83	7500	214	203	129	2.2	●	4600	131	125	79	2.3	●
75 x 115	71	61	46	40	124	M10	30	8	83	83	8000	213	189	123	2.3	●	5000	133	118	77	2.4	●
80 x 120	71	61	46	40	129	M10	30	8	83	83	8500	213	176	117	2.4	●	5200	130	108	72	2.6	●
85 x 125	71	61	46	40	134	M10	30	10	83	83	11400	268	209	142	2.6	●	7000	165	128	87	2.7	●
90 x 130	71	61	46	40	139	M10	30	10	83	83	12000	267	196	136	2.7	●	7400	164	121	84	2.8	●
95 x 135	71	61	46	40	144	M10	30	10	83	83	12600	265	185	130	2.8	●	7800	164	115	81	2.9	●
100 x 145	80	68	52	45	155	M12	35	8	145	145	15000	300	177	122	3.9	●	9800	196	116	80	4.1	●
110 x 155	80	68	52	45	165	M12	35	8	145	145	16500	300	161	114	4.2	●	10700	195	104	74	4.4	●
120 x 165	80	68	52	45	175	M12	35	10	145	145	22500	375	184	134	4.5	●	14600	243	120	87	4.7	●
130 x 180	80	68	52	45	188	M12	35	12	145	145	29000	446	202	146	5.5	●	19000	292	133	96	5.7	●
140 x 190	90	76	58	50	199	M14	40	10	210	230	32000	457	173	128	6.6	●	23000	329	125	92	6.9	●
150 x 200	90	76	58	50	209	M14	40	12	210	230	41000	547	193	145	6.9	●	30000	400	141	106	7.2	●
160 x 210	90	76	58	50	219	M14	40	12	210	230	44000	550	182	139	7.4	●	32000	400	133	101	7.8	●
170 x 225	90	76	58	50	234	M14	40	14	210	230	54500	641	200	151	8.6	●	39000	459	143	108	9.0	●
180 x 235	90	76	58	50	244	M14	40	14	210	230	57500	639	188	144	9.1	●	41000	456	134	103	9.5	●
190 x 250	90	76	58	50	259	M14	40	15	210	230	65000	684	191	145	10.6	●	46400	488	136	104	11.1	●
200 x 260	90	76	58	50	269	M14	40	15	210	230	68000	680	180	139	11.2	●	48800	488	129	100	11.7	●

● Sizes of clamping elements available from stock.

¹⁾ These are the maximum screw tightening torques. They can be reduced by a maximum of 40 % of the above-mentioned figures with T, F_{ax}, P_W and P_N decreasing proportionately.

NEW
NEW

CLAMPEX®

Clamping nuts

KTR Precision joints

Clamping sets

CLAMPEX® KTR 203 and KTR 206

Clamping elements

Self-centering clamping elements as a compact alternative to KTR 200/201

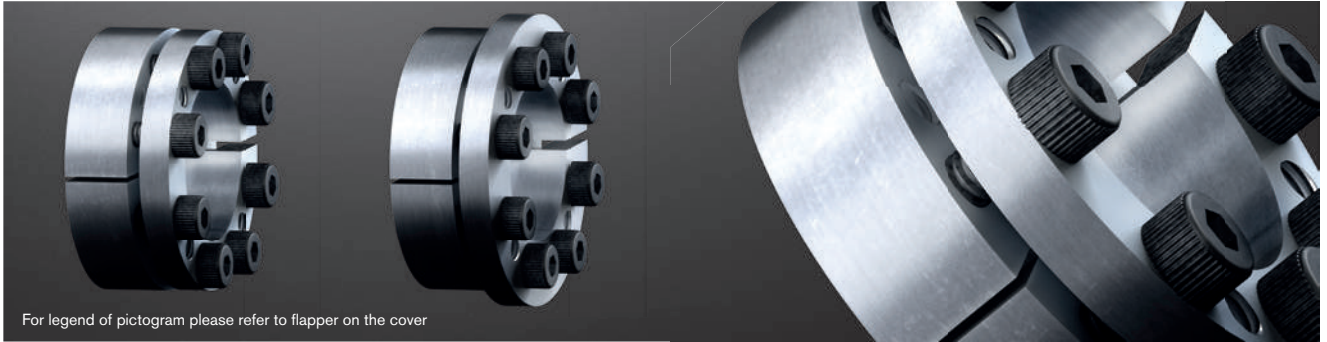

For legend of pictogram please refer to flapper on the cover

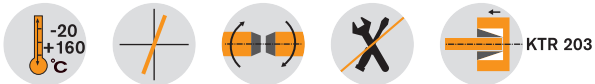

KTR 203

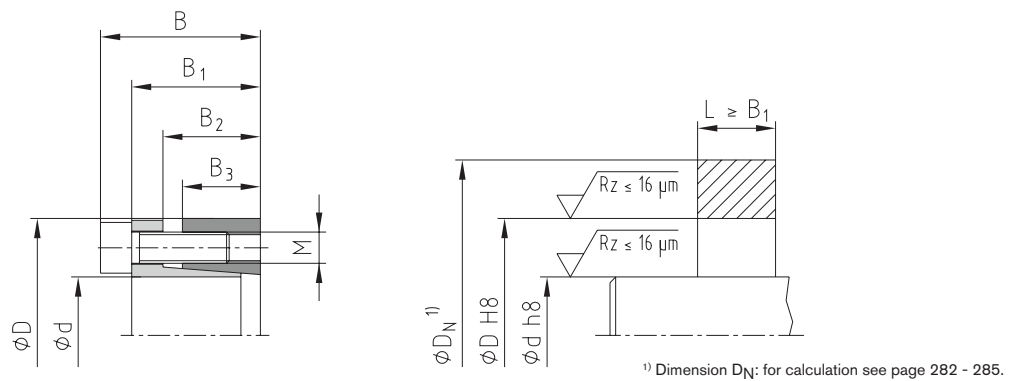

Example of application of hub design

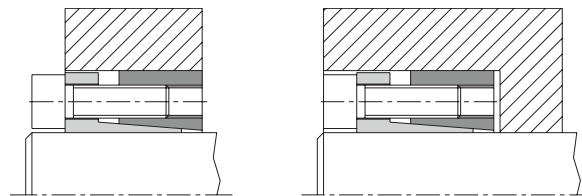

KTR 206

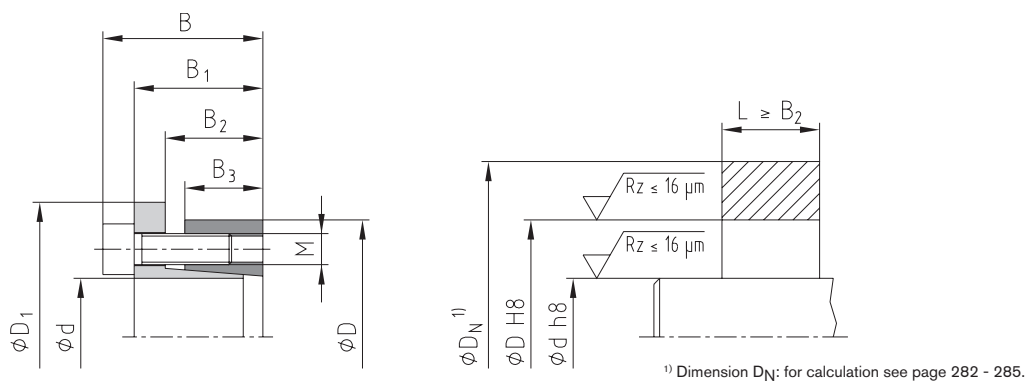

Example of application of hub design

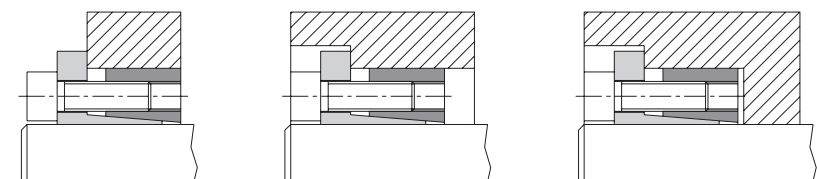

Ordering example:

KTR 203	40	x	65
Series	Size of internal diameter d		Size of external diameter D

CLAMPEX® – KTR 203 and KTR 206

d x D [mm]	Dimensions [mm]					Clamping screws DIN EN ISO 4762 - 12.9 $\mu_{total}=0.14$					KTR 203						KTR 206						
											Transmittable torque or axial force		Surface pressure between clamping element		Weight [-kg]	Stock programme	Transmittable torque or axial force		Surface pressure between clamping element		Weight [-kg]	Stock programme	
											T [Nm]	F _{ax} [kN]	Shaft P _W [N/mm ²]	Hub P _N [N/mm ²]			T [Nm]	F _{ax} [kN]	Shaft P _W [N/mm ²]	Hub P _N [N/mm ²]			
B	B ₁	B ₂	B ₃	D ₁	M	Length	z = number	T _A [Nm] ¹⁾															
								KTR 203	KTR 206														
NEW NEW	18 x 47	34	28	22	17	53	M6	20	6	14	17	370	41	356	136	0.3		290	32	279	107	0.3	
	19 x 47	34	28	22	17	53	M6	20	6	14	17	390	41	337	136	0.3		300	32	259	105	0.3	
	20 x 47	34	28	22	17	53	M6	20	6	14	17	410	41	320	136	0.3	●	320	32	250	106	0.3	●
	22 x 47	34	28	22	17	53	M6	20	6	14	17	450	41	290	136	0.3	●	350	32	226	106	0.3	●
	24 x 50	34	28	22	17	56	M6	20	6	14	17	490	41	265	127	0.3	●	390	33	211	101	0.3	●
	25 x 50	34	28	22	17	56	M6	20	6	14	17	510	41	255	127	0.3	●	400	32	200	100	0.3	●
	28 x 55	34	28	22	17	61.4	M6	20	6	14	17	570	41	227	116	0.3	●	450	32	179	91	0.4	●
	30 x 55	34	28	22	17	61.4	M6	20	6	14	17	610	41	212	115	0.3	●	490	33	170	93	0.3	●
	32 x 60	34	28	22	17.5	67	M6	20	8	14	17	880	55	261	139	0.4	●	700	44	207	111	0.3	●
	35 x 60	34	28	22	17.5	67	M6	20	8	14	17	960	55	238	139	0.3	●	760	43	188	110	0.4	●
	38 x 65	34	28	22	17.5	72	M6	20	8	14	17	1000	53	210	123	0.4	●	820	43	172	101	0.5	●
	40 x 65	34	28	22	17.5	72	M6	20	8	14	17	1100	55	208	128	0.4	●	870	44	165	101	0.4	●
	42 x 75	41	33	25	20	84	M8	25	8	35	41	2200	105	331	185	0.6	●	1700	81	256	143	0.7	●
	45 x 75	41	33	25	20	84	M8	25	8	35	41	2400	107	314	189	0.6	●	1800	80	236	141	0.7	●
	48 x 80	41	33.5	24	20	89	M8	25	8	35	41	2500	104	288	173	0.7	●	1900	79	219	131	0.8	●
	50 x 80	41	33.5	24	20	89	M8	25	8	35	41	2600	104	276	172	0.7	●	2000	80	212	133	0.8	●
	55 x 85	41	33.5	24	20	94	M8	25	8	35	41	2900	105	254	165	0.7	●	2200	80	193	125	0.9	●
	60 x 90	41	33.5	24	20	99	M8	25	8	35	41	3100	103	228	152	0.8	●	2400	80	177	118	0.9	●
	65 x 95	41	33.5	24	20	104	M8	25	8	35	41	3400	105	213	146	0.8	●	2600	80	163	112	0.9	●
	70 x 110	50	40	29	24	119	M10	30	8	70	83	6000	171	271	172	1.5	●	4600	131	208	132	1.6	●
	75 x 115	50	40	29	24	124	M10	30	8	70	83	6400	171	252	164	1.6	●	5000	133	196	128	1.7	●
	80 x 120	50	40	29	24	129	M10	30	8	70	83	6800	170	235	157	1.7	●	5300	133	183	122	1.9	●
	85 x 125	50	40	29	24	134	M10	30	10	70	83	9000	212	275	187	1.8	●	7000	165	214	146	2.0	●
	90 x 130	50	40	29	24	139	M10	30	10	70	83	9600	213	262	181	1.9	●	7400	164	202	140	2.0	●
	95 x 135	50	40	29	24	144	M10	30	10	70	83	10200	215	250	176	2.0	●	7800	164	191	134	2.3	●
	100 x 145	56	44	31	25.5	154	M12	30	8	115	145	12000	240	250	172	2.6	●	9700	194	202	139	2.8	●
	110 x 155	56	44	31	25.5	164	M12	30	8	115	145	13000	236	224	159	2.8	●	10700	195	184	131	3.1	●
	120 x 165	56	44	31	26	174	M12	30	9	115	145	16000	267	227	165	3.6	●	13100	218	186	135	3.2	●
	130 x 180	64	52	39	34	189	M12	30	12	115	145	23000	354	212	153	4.4	●	19000	292	175	127	4.6	●
	140 x 190	68	54	39	34	199	M14	40	9	185	230	25000	357	199	147	4.9	●	20500	293	163	120	5.0	●
	150 x 200	68	54	39	34	209	M14	40	10	185	230	30000	400	208	156	5.2	●	24500	327	170	127	5.2	●
	160 x 210	68	54	39	34	219	M14	40	12	185	230	38800	485	236	180	5.6	●	31300	391	191	145	5.6	●
	170 x 225	78	64	49	44	234	M14	40	12	185	230	41300	486	172	130	6.9	●	33200	391	139	105	6.5	●
	180 x 235	78	64	49	44	244	M14	40	12	185	230	43700	486	163	125	8.5	●	35000	389	130	100	8.5	●
	190 x 250	78	64	49	43.5	259	M14	40	15	185	230	57700	607	195	148	9.0	●	46500	489	157	119	9.0	●
	200 x 260	78	64	49	43.5	269	M14	40	15	185	230	60700	607	185	142	9.6	●	49000	490	149	115	9.6	●
	220 x 285	88	72	57	50	294	M16	40	12	290	360	77300	703	169	131	13.4	●	57100	519	125	97	14.0	●
	240 x 305	88	72	57	50	314	M16	40	15	290	360	105400	878	194	153	14.5	●	77800	648	143	113	15.1	●
	260 x 325	88	72	57	50	334	M16	40	18	290	360	137000	1054	215	172	16.1	●	101200	778	159	127	16.2	●
	280 x 355	102	84	66	60	364	M18	50	16	400	480	160300	1145	181	143	23.4	●	113300	809	128	101	25.6	●
	300 x 375	102	84	66	60	384	M18	50	18	400	480	193200	1288	190	152	25.3	●	136500	910	134	107	25.5	●
	320 x 405	121	101	81	74	414	M20	50	18	580	690	269300	1683	189	149	36.9	●	191000	1194	134	106	37.9	●
NEW	340 x 425	121	101	81	74	434	M20	50	21	580	690	333800	1964	207	166	39.0	●	237000	1394	147	118	38.3	●
NEW	360 x 455	138	116	93	86	464	M22	60	18	780	930	375700	2087	179	141	54.0	●	264000	1467	126	99	53.3	●
NEW	380 x 475	138	116	93	86	484	M22	60	21	780	930	462700	2435	198	158	56.2	●	325000	1711	139	111	57.6	●
NEW	400 x 495	138	116	93	86	504	M22	60	21	780	930	487000	2435	188	152	58.9	●	342000	1710	132	107	60.3	●

● Sizes of clamping elements available from stock.

¹⁾ These are the maximum screw tightening torques. They can be reduced by a maximum of 40 % of the above-mentioned figures with T, F_{ax}, P_W and P_N decreasing proportionately.

CLAMPEX®

Clamping nuts

KTR Precision joints

Clamping sets

CLAMPEX® KTR 225

Clamping elements

Self-centering, combination of a hub \varnothing with various shaft \varnothing



For legend of pictogram please refer to flapper on the cover

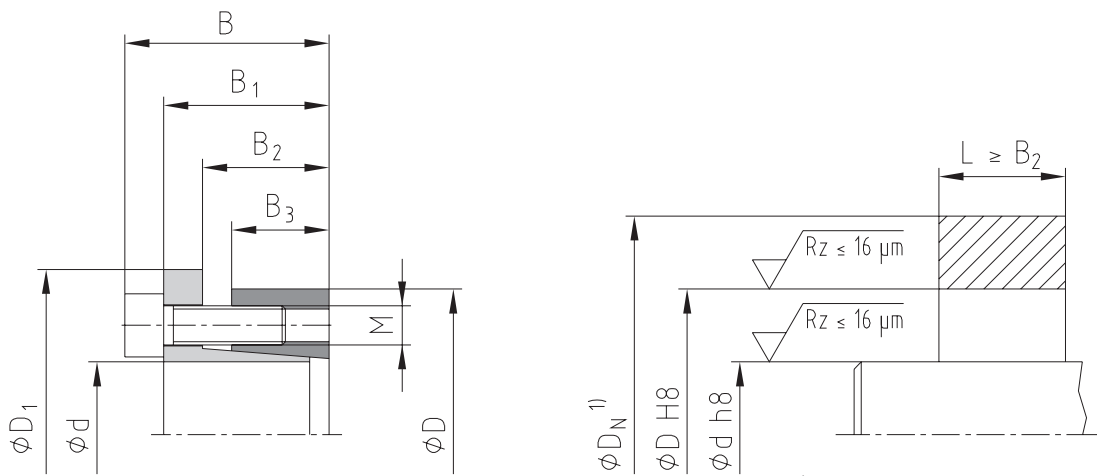

¹⁾ Dimension D_N : for calculation see page 282 - 285.

Example of application of hub design

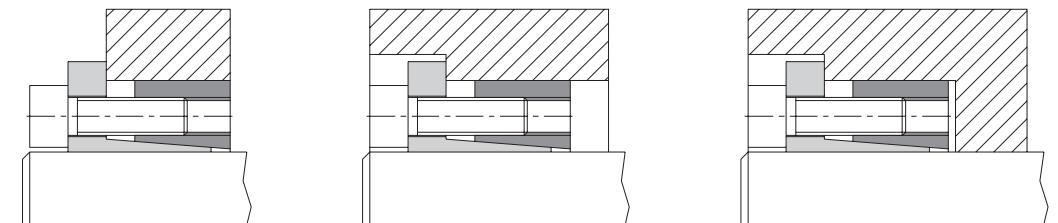

To fasten one size of hub on different shaft diameters

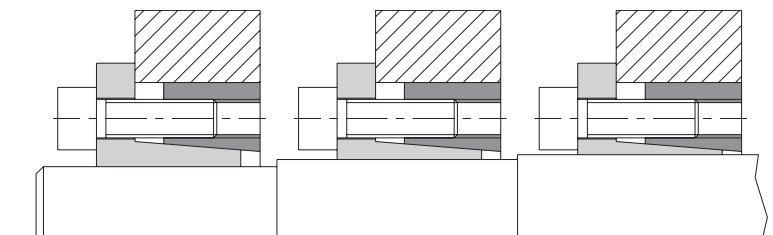

Ordering example:	KTR 225	28	x	65
	Series	Size of internal diameter d		Size of external diameter D

CLAMPEX® – KTR 225															
d x D [mm]	Dimensions [mm]					Clamping screws DIN EN ISO 4762 - 12.9 $\mu_{total}=0.14$				Transmittable torque or axial force		Surface pressure between clamping element		Weight [-kg]	Stock programme
	B	B ₁	B ₂	B ₃	D ₁	M	Length	z = number	T _A ¹⁾ [Nm]	T [Nm]	F _{ax} [kN]	Shaft P _W [N/mm ²]	Hub P _N [N/mm ²]		
14 x 55	38	30	22	17	62	M8	25	4	41	287	41	457	116	0.5	●
16 x 55	38	30	22	17	62	M8	25	4	41	329	41	401	117	0.5	●
18 x 55	38	30	22	17	62	M8	25	4	41	370	41	356	117	0.5	●
19 x 55	38	30	22	17	62	M8	25	4	41	390	41	337	116	0.5	●
20 x 55	38	30	22	17	62	M8	25	4	41	410	41	320	116	0.5	●
22 x 55	38	30	22	17	62	M8	25	4	41	451	41	291	116	0.5	●
24 x 55	38	30	22	17	62	M8	25	4	41	492	41	267	116	0.4	●
25 x 55	38	30	22	17	62	M8	25	4	41	513	41	256	116	0.4	●
28 x 55	38	30	22	17	62	M8	25	4	41	575	41	229	117	0.4	●
30 x 55	38	30	22	17	62	M8	25	4	41	616	41	214	117	0.4	●
24 x 65	38	30	22	17	72	M8	25	5	41	616	51	334	123	0.7	●
25 x 65	38	30	22	17	72	M8	25	5	41	641	51	320	123	0.7	●
28 x 65	38	30	22	17	72	M8	25	5	41	718	51	286	123	0.6	●
30 x 65	38	30	22	17	72	M8	25	5	41	770	51	267	123	0.6	●
32 x 65	38	30	22	17	72	M8	25	5	41	821	51	250	123	0.6	●
35 x 65	38	30	22	17	72	M8	25	5	41	898	51	229	123	0.5	●
38 x 65	38	30	22	17	72	M8	25	5	41	975	51	211	123	0.5	●
40 x 65	38	30	22	17	72	M8	25	5	41	1026	51	200	123	0.5	●
30 x 80	41	33	25	20	88	M8	25	7	41	1077	72	317	119	1.1	
32 x 80	41	33	25	20	88	M8	25	7	41	1150	72	298	119	1.1	
35 x 80	41	33	25	20	88	M8	25	7	41	1257	72	272	119	1.0	
38 x 80	41	33	25	20	88	M8	25	7	41	1364	72	251	119	1.0	
40 x 80	41	33	25	20	88	M8	25	7	41	1436	72	238	119	0.9	●
42 x 80	41	33	25	20	88	M8	25	7	41	1509	72	227	119	0.9	
45 x 80	41	33	25	20	88	M8	25	7	41	1616	72	212	119	0.9	
48 x 80	41	33	25	20	88	M8	25	7	41	1723	72	198	119	0.8	
50 x 80	41	33	25	20	88	M8	25	7	41	1796	72	191	119	0.8	●

● Sizes of clamping elements available from stock.

¹⁾ These are the maximum screw tightening torques. They can be reduced by a maximum of 40 % of the above-mentioned figures with T, F_{ax}, P_W and P_N decreasing proportionately.

CLAMPEX® KTR 250

Clamping elements

Self-centering clamping element, particularly suitable for thin-walled hubs

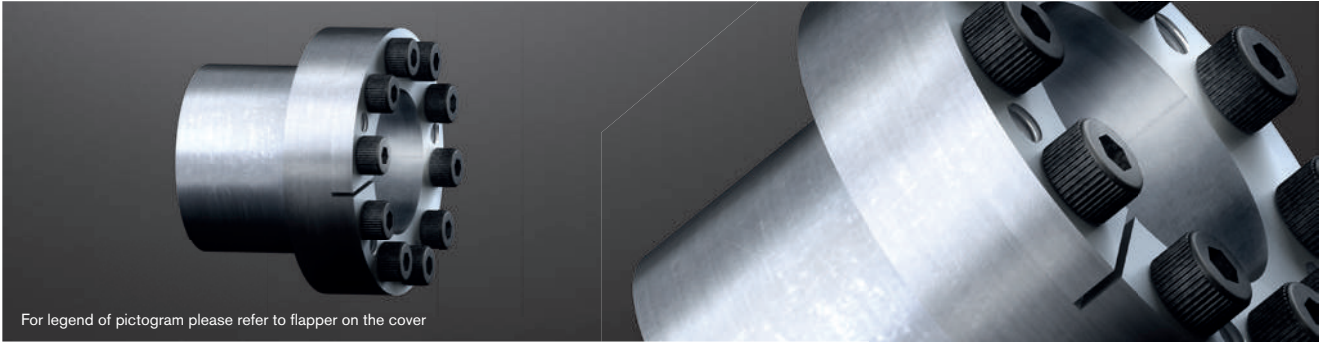

For legend of pictogram please refer to flapper on the cover

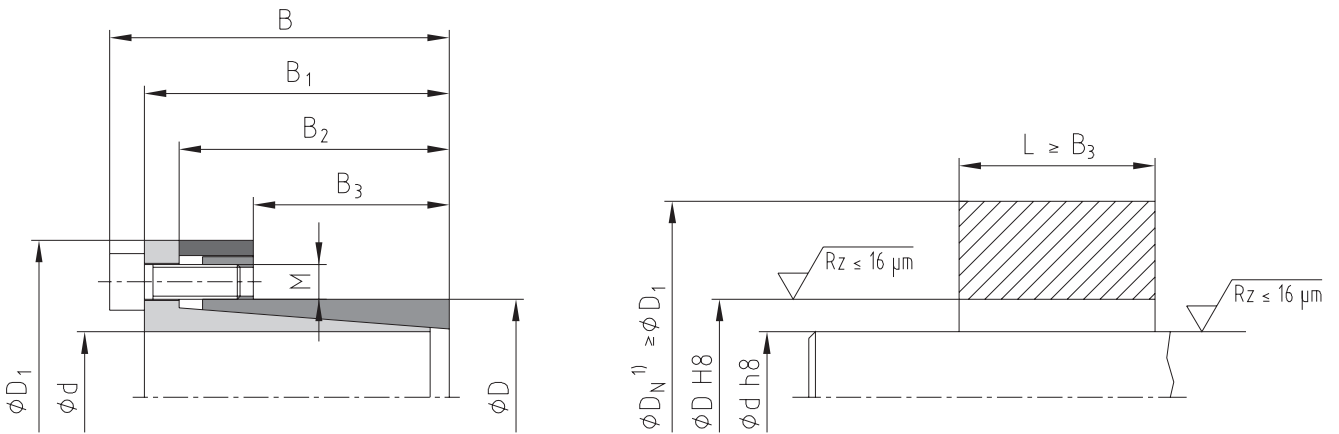

¹⁾ Dimension D_N : for calculation see page 282 - 285.

Example of application of hub design

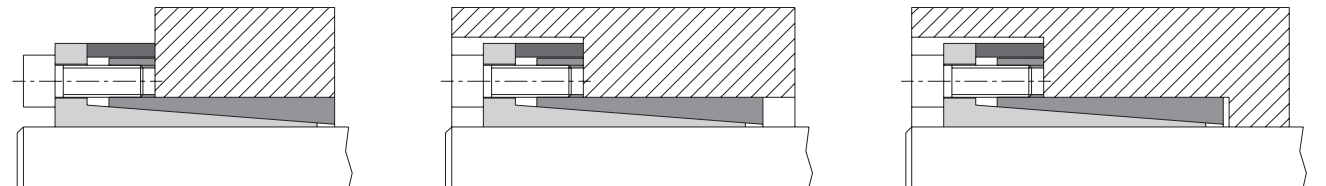

Ordering example:	KTR 250	28	x	39
	Series	Size of internal diameter d		Size of external diameter D

CLAMPEX® – KTR 250

d x D [mm]	Dimensions [mm]					Clamping screws DIN EN ISO 4762 - 12.9 $\mu_{total}=0.14$				Transmittable torque or axial force		Surface pressure between clamping element		Weight [~kg]	Stock programme
	B	B ₁	B ₂	B ₃	D ₁	M	Length	z = number	T _A [Nm] ¹⁾	T [Nm]	F _{ax} [kN]	Shaft P _W [N/mm ²]	Hub P _N [N/ mm ²]		
6 x 14	24.5	21.5	18.5	10	25	M3	10	4	2.6	11	4	162	69	0.05	●
8 x 15	29	25	21.5	11.5	27	M4	10	3	5.6	26	7	187	100	0.05	●
9 x 16	30	26	22.5	14	28	M4	10	4	5.6	37	8	173	97	0.06	●
10 x 16	30	26	22.5	14	29	M4	10	4	5.6	42	8	159	99	0.16	●
11 x 18	30	26	22.5	13.5	32	M4	10	4	5.6	50	9	162	99	0.18	●
12 x 18	30	26	22.5	13.5	32	M4	10	4	5.6	55	9	150	100	0.18	●
14 x 23	30	26	22.5	14	38	M4	10	6	5.6	100	14	193	118	0.20	●
15 x 24	42	36	28.5	16	44	M6	18	4	15	145	19	214	134	0.2	●
16 x 24	42	36	28.5	16	44	M6	18	4	15	155	19	201	134	0.3	●
17 x 25	42	36	28.5	16	45	M6	18	4	15	162	19	186	126	0.2	●
17 x 26	44	38	31	18	47	M6	18	4	17	180	21	184	120	0.2	●
18 x 26	44	38	31	18	47	M6	18	4	17	200	22	182	126	0.2	●
19 x 27	44	38	31	18	48	M6	18	4	17	210	22	171	121	0.3	●
20 x 28	44	38	31	18	49	M6	18	4	17	220	22	162	116	0.2	●
22 x 32	51	45	38	25	54	M6	18	4	17	250	23	110	75	0.3	●
24 x 34	51	45	38	25	56	M6	18	4	17	270	23	99	70	0.3	●
25 x 34	51	45	38	25	56	M6	18	4	17	280	22	95	70	0.3	●
28 x 39	51	45	38	25	61	M6	18	6	17	480	34	130	93	0.4	●
30 x 41	51	45	38	25	62	M6	18	6	17	510	34	120	88	0.4	●
32 x 43	51	45	38	25	65	M6	18	8	17	730	46	151	113	0.5	●
35 x 47	56	50	43	30	69	M6	18	8	17	800	46	115	86	0.5	●
38 x 50	56	50	43	30	72	M6	18	8	17	860	45	105	80	0.6	●
40 x 53	56	50	43	30	75	M6	18	8	17	900	45	99	75	0.6	●
42 x 55	65	57	49	32	78	M8	22	8	41	1800	86	169	129	0.9	●
45 x 59	73	65	57	40	85	M8	22	8	41	1900	84	124	95	1.0	●
48 x 62	78	70	62	45	87	M8	22	8	41	2000	83	102	79	1.0	●
50 x 65	78	70	62	45	92	M8	22	10	41	2600	104	123	94	1.3	●
55 x 71	83	75	67	50	98	M8	22	10	41	2900	105	102	79	1.5	●
60 x 77	83	75	67	50	104	M8	22	10	41	3100	103	91	71	1.7	●
65 x 84	83	75	67	50	111	M8	22	10	41	3400	105	85	66	1.9	●
70 x 90	101	91	80	60	119	M10	25	10	83	5800	166	105	81	2.9	●
75 x 95	101	91	80	60	126	M10	25	10	83	6200	165	97	77	2.3	●
80 x 100	106	96	85	65	131	M10	25	12	83	8000	200	102	82	3.3	●
85 x 106	106	96	85	65	137	M10	25	12	83	8500	200	96	77	3.6	●
90 x 112	106	96	85	65	143	M10	25	15	83	11200	249	113	91	3.9	●
95 x 120	106	96	85	65	153	M10	25	15	83	11800	248	107	84	4.5	●
100 x 125	114	102	89	65	162	M12	30	12	145	14600	292	119	95	5.5	●
110 x 140	140	128	114	90	180	M12	30	12	145	16000	291	78	61	8.0	●
120 x 155	140	128	114	90	198	M12	30	12	145	17400	290	71	55	10.5	●
130 x 165	140	128	114	90	208	M12	30	16	145	25000	385	87	69	11.9	●

● Sizes of clamping elements available from stock.

¹⁾ These are the maximum screw tightening torques. They can be reduced by a maximum of 40 % of the above-mentioned figures with T, F_{ax}, P_W and P_N decreasing proportionately.

CLAMPEX® KTR 400

Clamping elements

Self-centering clamping element with highest transmission performance

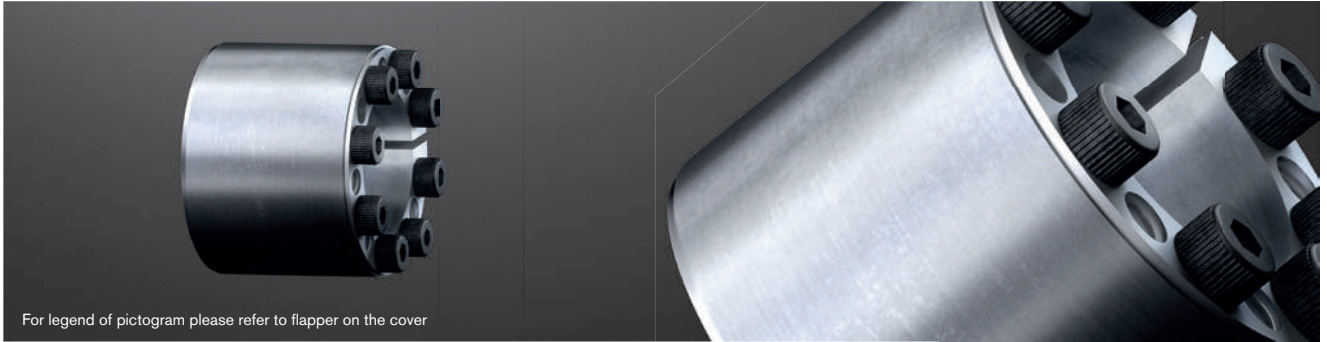

For legend of pictogram please refer to flapper on the cover

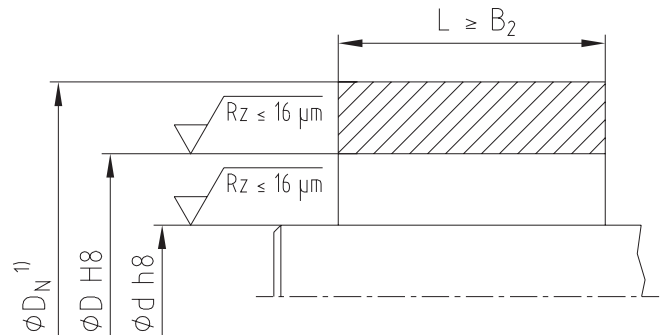
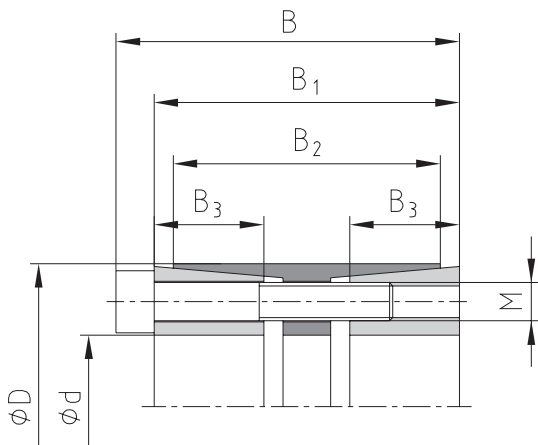
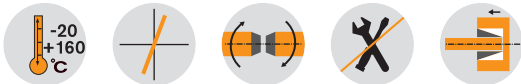

¹⁾ Dimension D_N : for calculation see page 282 - 285.

Example of application of hub design

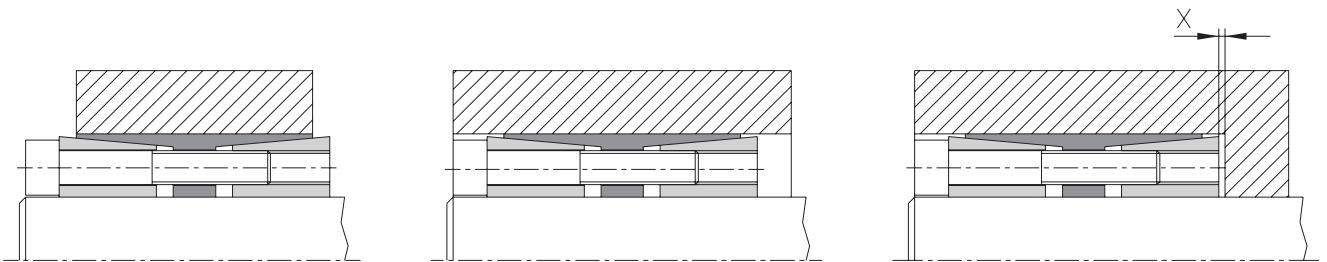

Formula to calculate space x for disassembly:

$$x = \frac{B_1 - B_2}{2}$$

Ordering example:	KTR 400	100	x	145
	Series	Size of internal diameter d		Size of external diameter D

CLAMPEX® – KTR 400

d x D ¹⁾ [mm]	Dimensions [mm]				Standard applications in industry								Applications with components subject to bending and torsion stress								Weight [-kg]	Stock programme	
					Clamping screws DIN EN ISO 4762 - 12.9 $\mu_{total}=0.14$				Transmittable torque or axial force		Surface pressure between clamp- ing element		Clamping screws DIN EN ISO 4762 - 12.9 $\mu_{total}=0.14$				Transmittable torque or axial force		Trans- mittable bending moment				Surface pressure between clamp- ing element
	B	B ₁	B ₂	B ₃	M	z = num- ber	Length	T _A ²⁾ [Nm]	T [Nm]	F _{ax} [kN]	Shaft P _W [N/mm ²]	Hub P _N [N/mm ²]	M	z = num- ber	Length	T _A [Nm]	T [Nm]	F _{ax} [kN]	M _b perm. [Nm]	Shaft P _W [N/mm ²]			Hub P _N [N/mm ²]
24 x 50	51	45	41	16	M6	6	35	17	700	58	202	92	M6	6	35	14	460	38	420	230	93	0.5	●
25 x 50	51	45	41	16	M6	6	35	17	730	58	194	92	M6	6	35	14	470	38	430	222	94	0.5	●
28 x 55	51	45	41	16	M6	8	35	17	1100	79	233	112	M6	8	35	14	740	53	490	257	110	0.5	●
30 x 55	51	45	41	16	M6	8	35	17	1180	79	217	112	M6	8	35	14	790	53	520	243	112	0.5	●
32 x 60	51	45	41	16	M6	8	35	17	1270	79	206	103	M6	8	35	14	830	52	560	230	104	0.8	●
35 x 60	51	45	41	16	M6	8	35	17	1390	79	188	104	M6	8	35	14	890	51	610	214	106	0.7	●
38 x 65	51	45	41	16	M6	10	35	17	1880	99	216	119	M6	10	35	14	1250	66	660	240	119	1.1	●
40 x 65	51	45	41	16	M6	10	35	17	1980	99	205	119	M6	10	35	14	1300	65	700	230	120	1.1	●
40 x 75	51	45	41	16	M8	8	35	41	2850	143	296	149	M8	8	35	35	2030	102	700	320	142	1.1	●
42 x 75	51	45	41	16	M8	8	35	41	3000	143	282	149	M8	8	35	35	2120	101	730	307	142	1.2	●
45 x 75	51	45	41	16	M8	8	35	41	3250	144	266	151	M8	8	35	35	2260	100	780	289	145	1.1	●
48 x 80	70	62	58	23	M8	8	55	41	3450	144	173	98	M8	8	55	35	2160	90	1700	202	101	1.5	●
50 x 80	70	62	58	23	M8	8	55	41	3600	144	166	98	M8	8	55	35	2220	89	1770	196	102	1.4	●
55 x 85	70	62	58	23	M8	8	55	41	3950	144	151	92	M8	8	55	35	2350	85	1950	182	98	1.5	●
60 x 90	70	62	58	23	M8	10	55	41	5400	180	173	109	M8	10	55	35	3380	113	2130	202	113	1.6	●
65 x 95	70	62	58	23	M8	10	55	41	5850	180	160	103	M8	10	55	35	3560	110	2310	190	109	1.7	●
70 x 110	86	76	70	28	M10	10	60	83	10200	291	197	118	M10	10	60	69	6620	189	3650	222	120	3.1	●
75 x 115	86	76	70	28	M10	10	60	83	10950	292	184	113	M10	10	60	69	6970	186	3920	210	117	3.3	●
80 x 120	86	76	70	28	M10	12	60	83	14000	350	207	130	M10	12	60	69	9210	230	4180	231	131	3.5	●
85 x 125	86	76	70	28	M10	12	60	83	15000	353	197	126	M10	12	60	69	9710	228	4440	220	129	3.6	●
90 x 130	86	76	70	28	M10	12	60	83	15800	351	185	121	M10	12	60	69	10000	222	4700	210	124	3.8	●
95 x 135	86	76	70	28	M10	12	60	83	16800	354	176	117	M10	12	60	69	10500	221	4960	201	122	4.0	●
100 x 145	110	98	92	35	M12	12	80	145	26000	520	197	121	M12	12	80	120	16850	337	8580	219	124	6.1	●
110 x 155	110	98	92	35	M12	12	80	145	28600	520	179	114	M12	12	80	120	18000	327	9440	203	118	6.6	●
120 x 165	110	98	92	35	M12	14	80	145	36300	605	191	124	M12	14	80	120	23350	389	10300	214	128	7.1	●
130 x 180	128	114	108	41	M14	12	90	230	46000	708	176	114	M14	12	90	190	29950	461	15300	201	119	10.0	●
140 x 190	128	114	108	41	M14	14	90	230	57800	826	191	126	M14	14	90	190	37200	531	16500	214	129	10.6	●
150 x 200	128	114	108	41	M14	16	90	230	70800	944	204	136	M14	16	90	190	46400	619	17700	226	139	11.2	●
160 x 210	128	114	108	41	M14	16	90	230	75500	944	191	130	M14	16	90	190	48600	608	18800	214	133	11.9	●
170 x 225	162	146	136	52	M16	14	110	355	95900	1128	169	114	M16	14	110	295	59100	695	32000	196	119	17.6	●
180 x 235	162	146	136	52	M16	15	110	355	108800	1209	171	117	M16	15	110	295	67500	750	33900	198	122	18.5	●
190 x 250	162	146	136	52	M16	16	110	355	122500	1289	173	117	M16	16	110	295	76100	801	35800	199	122	21.4	●
200 x 260	162	146	136	52	M16	16	110	355	128900	1289	164	113	M16	16	110	295	78600	786	37700	192	118	22.4	●
220 x 285	162	146	136	52	M16	18	110	355	171800	1562	181	120	M16	18	110	295	105000	955	41400	195	126	26.6	●
240 x 305	162	146	136	52	M16	20	110	355	208000	1733	184	125	M16	20	110	295	128000	1067	45200	198	130	28.7	●
260 x 325	166	150	134	55	M16	21	110	355	237000	1823	169	117	M16	21	110	295	142000	1092	51000	187	123	31.2	●
280 x 355	197	177	165	66	M20	18	130	690	340000	2429	174	119	M20	18	130	580	208000	1486	81300	192	125	46.8	●
300 x 375	197	177	165	66	M20	20	130	690	405000	2700	181	125	M20	20	130	580	252000	1680	87100	198	130	69.7	●
320 x 405	197	177	165	66	M20	21	130	690	453000	2831	178	121	M20	21	130	580	280000	1750	92900	196	127	60.5	●
340 x 425	197	177	165	66	M20	22	130	690	504900	2970	176	121	M20	22	130	580	311000	1829	98700	193	127	63.9	●
360 x 455	224	203	190	76	M22	21	150	930	626000	3478	169	115	M22	21	150	780	381000	2117	138500	189	121	86.8	●
380 x 475	224	203	190	76	M22	22	150	930	692000	3642	167	115	M22	22	150	780	420000	2211	146000	188	122	91.0	●
400 x 495	224	203	190	76	M22	24	150	930	795000	3975	173	121	M22	24	150	780	489000	2445	154000	194	127	95.3	●
420 x 515	224	203	190	76	M22	24	150	930	835000	3976	165	116	M22	24	150	780	505000	2405	161500	186	123	100	●
440 x 535	224	203	190	76	M22	24	150	930	875000	3977	158	112	M22	24	150	780	517000	2350	169000	178	120	105	●
460 x 555	224	203	190	76	M22	24	150	930	914000	3974	151	108	M22	24	150	780	530000	2304	177000	172	117	109	●
480 x 575	224	203	190	76	M22	28	150	930	1113000	4638	169	121	M22	28	150	780	678000	2825	184500	189	128	114	●
500 x 595	224	203	190	76	M22	28	150	930	1160000	4640	162	117	M22	28	150	780	692000	2768	192000	182	125	119	●
520 x 615	224	203	190	76	M22	30	150	930	1292000	4969	167	122	M22	30	150	780	780000	3000	200000	186	129	122.5	●
540 x 635	224	203	190	76	M22	30	150	930	1342000	4970	161	118	M22	30	150	780	799000	2959	207500	180	126	128	●
560 x 655	224	203	190	76	M22	32	150	930	1484000	5300	165	122	M22	32	150	780	893000	3189	215500	184	129	131	●
580 x 675	224	203	190	76	M22	32	150	930	1537000	5300	159	118	M22	32	150	780	912000	3145	223000	179	127	136	●
600 x 695	224	203	190	76	M22	33	150	930	1640000	5467	159	118	M22	33	150	780	972000	3240	231000	179	127	139	●

● Sizes of clamping elements available from stock.

¹⁾ External ring from size 400 x 495 without slot.

²⁾ These are the maximum screw tightening torques. They can be reduced by a maximum of 40 % of the above-mentioned figures with T, F_{ax}, P_W and P_N decreasing proportionately.

CLAMPEX®

Clamping nuts

KTR Precision joints

Clamping sets

CLAMPEX® KTR 603

Clamping elements

Three-part external clamping set for applications on hollow shafts

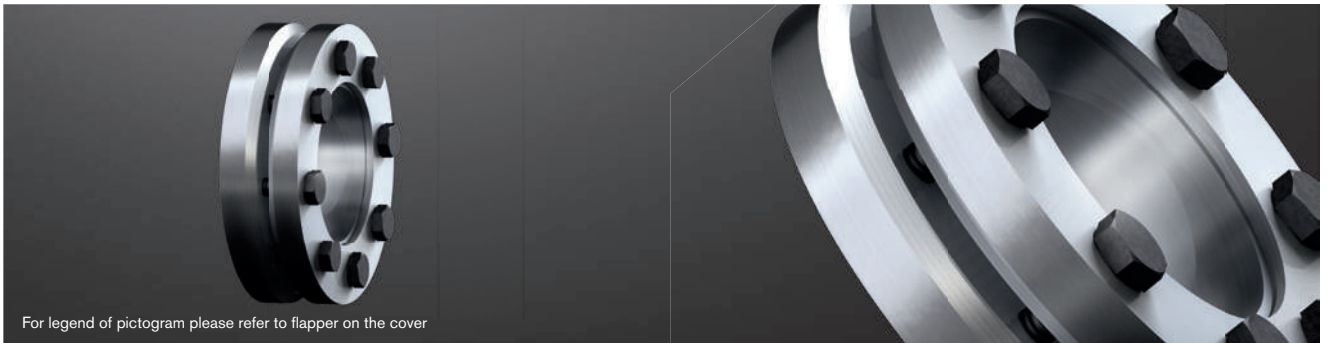

For legend of pictogram please refer to flapper on the cover

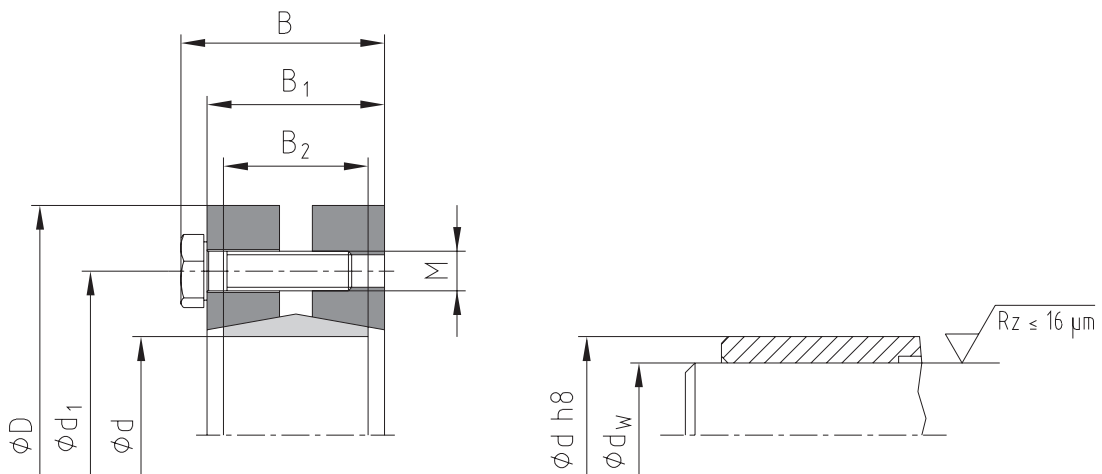

Tolerances for d_w

For d_w from 10 to 30 mm **H6 / j6**

For d_w from 31 to 50 mm **H6 / h6**

For d_w from 51 to 80 mm **H6 / g6**

For d_w from 81 to 500 mm **H7 / g6**

Bigger tolerances are generally possible! Please contact us!

Example of application of hub design

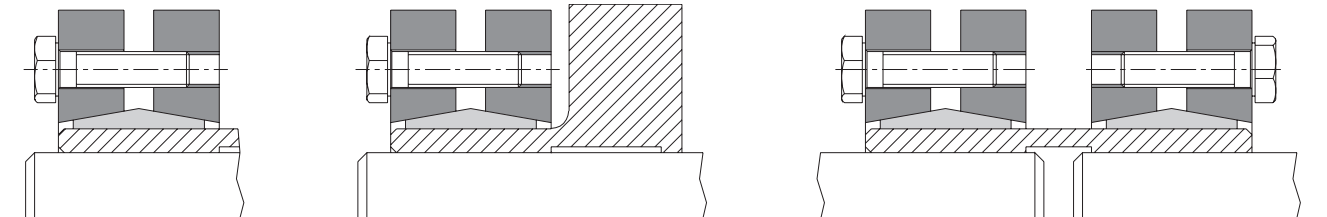

Ordering
example:

KTR 603	44	x	80
Series	Size of internal diameter d		Size of external diameter D

CLAMPEX® – KTR 603

d x D [mm]	Shaft diameter d _w [mm]	Transmittable torque or axial force		Dimensions [mm]				Clamping screws DIN EN ISO 4014 - 10.9 μ _{total} =0.10				Surface pressure of clamping element/hollow shaft P _H [N/mm ²]	Weight [~kg]	Stock programme	
		T [Nm]	F _{ax} [kN]	B	B ₁	B ₂	d ₁	M	Length	z = number	T _A [Nm]				
14 x 38	10	28	6												
	11	38	7	14.5	11	9	24	M5	10	4	3.5	388	0.1	●	
	12	50	8												
16 x 41	12	50	8												
	13	70	11	18.5	15	11	26	M5	14	5	4	310	0.2	●	
	14	90	13												
24 x 50	19	180	19												
	20	210	21	22.5	19	14	36	M5	18	6	5	286	0.2	●	
	21	250	24												
30 x 60	24	310	26												
	25	340	27	24.5	21	16	44	M5	18	6	6	233	0.3	●	
	26	380	29												
36 x 72	28	460	33												
	30	590	39	27	23	18	52	M6	20	5	12	307	0.4	●	
	31	630	41												
44 x 80	32	630	39												
	35	780	45	29	25	20	61	M6	22	7	12	317	0.6	●	
	36	860	48												
50 x 90	38	940	49												
	40	1100	55	31	27	22	70	M6	22	8	12	289	0.8	●	
	42	1300	62												
55 x 100	42	1200	57												
	45	1500	67	34	30	23	75	M6	25	8	12	252	1.1	●	
	48	1900	79												
62 x 110	48	1800	75												
	50	2200	88	34	30	23	86	M6	25	10	12	279	1.3	●	
	52	2400	92												
68 x 115	50	2000	80												
	55	2500	91	34	30	23	86	M6	25	10	12	255	1.4	●	
	60	3100	103												
75 x 138	55	2500	91												
	60	3200	107	37.5	32	25	100	M8	30	7	30	273	1.8	●	
	65	3900	120												
80 x 145	60	3200	107												
	65	3900	120	37.5	32	25	100	M8	30	7	30	256	2.6	●	
	70	4600	131												
85 x 155	65	4800	148												
	70	6100	174	44.5	39	30	114	M8	35	10	30	285	3.9		
	75	7400	197												
90 x 155	65	4700	145												
	70	6000	171	44.5	39	30	114	M8	35	10	30	217	3.8	●	
	75	7200	192												
100 x 170	70	6900	197												
	75	7500	200	49.5	44	34	124	M8	35	12	30	227	4.7	●	
	80	9000	225												
110 x 185	75	7200	192												
	80	9000	225	56.5	50	39	136	M10	40	9	59	215	6.0	●	
	85	11000	259												
115 x 188	80	8500	213												
	85	10000	235	56.5	50	39	141	M10	40	9	59	209	5.0		
	90	12000	267												
120 x 215	80	10500	263												
	85	13200	311	58.5	52	42	160	M10	40	12	59	271	5.9		
	90	14400	320												
125 x 215	85	11000	259												
	90	13000	289	58.5	52	42	160	M10	40	12	59	222	8.5	●	
	95	15000	316												
130 x 215	90	13700	304												
	95	15800	333	58.5	52	42	160	M10	40	12	59	227	9.0		
	100	18200	364												
140 x 230	95	15000	316												
	100	17000	340	67.5	60	46	175	M12	45	10	100	209	11		
	105	20000	381												

● Sizes of clamping elements available from stock.
Other sizes on request.

CLAMPEX® KTR 603

Clamping elements

Three-part external clamping set for applications on hollow shafts

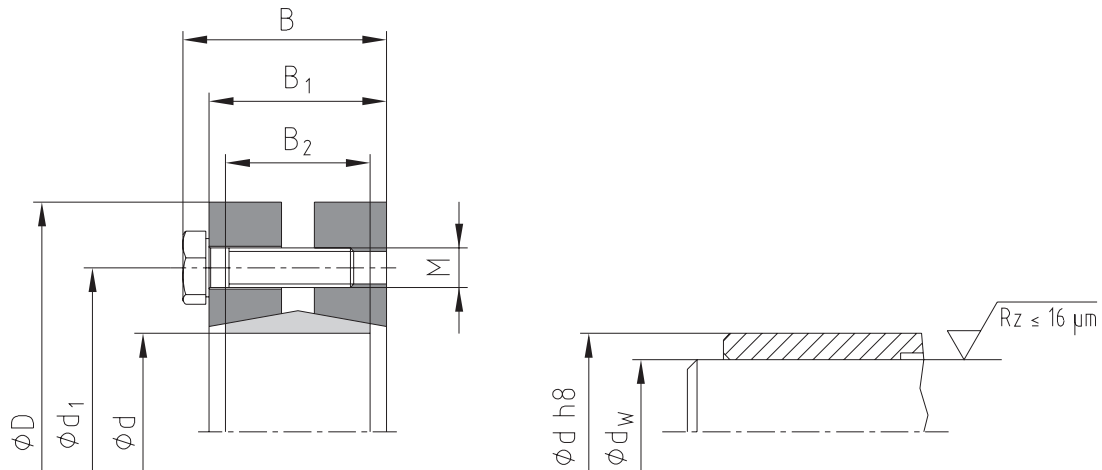

CLAMPEX® – KTR 603														
d x D [mm]	Shaft diameter d _w [mm]	Transmittable torque or axial force		Dimensions [mm]				Clamping screws DIN EN ISO 4014 - 10.9 μ _{total} =0.10				Surface pressure of clamping element/hollow shaft	Weight [~kg]	Stock programme
		T [Nm]	F _{ax} [kN]	B	B ₁	B ₂	d ₁	M	Length	z = number	T _A [Nm]	P _H [N/mm ²]		
155 x 265	105	20000	381	71.5	64	50	192	M12	50	12	100	212	15	
	110	23000	418											
	115	26000	452											
NEW 160x 265	110	22500	409	71.5	64	50	192	M12	50	12	100	204	14	
	115	25500	443											
	120	28600	477											
165 x 290	115	36000	626	81	71	56	210	M16	60	8	250	269	24	
	120	39000	650											
	125	44000	704											
NEW 170 x 290	120	31700	528	81	71	56	210	M16	60	8	250	216	24	
	125	35800	573											
	130	40000	615											
175 x 300	125	40000	640	81	71	56	220	M16	60	8	250	253	16	
	130	44000	677											
	135	49000	726											
NEW 180 x 300	130	36800	566	81	71	56	220	M16	60	8	250	211	16	
	135	42000	622											
	140	46000	657											
185 x 330	135	55000	815	96	86	71	236	M16	65	10	250	231	35	
	140	60000	857											
	145	65000	897											
NEW 190 x 330	140	53300	761	96	86	71	236	M16	65	10	250	201	35	
	145	58500	807											
	150	63500	847											
195 x 350	140	66000	943	96	86	71	246	M16	65	12	250	259	38	
	150	76000	1013											
	155	82000	1058											
200 x 350	150	73700	983	96	86	71	246	M16	65	12	250	240	41	
	155	79800	1030											
	160	85800	1073											
220 x 370	160	95000	1188	114	104	88	270	M16	80	15	250	216	54	
	165	102000	1236											
	170	110000	1294											
240 x 405	170	120000	1412	121.5	109	92	295	M20	80	12	490	239	67	
	180	140000	1556											
	190	160000	1684											
NEW 250 x 405	180	160000	1778	120.5	108	92	295	M20	85	14	490	263	64	
	190	180000	1895											
	200	200000	2000											
260 x 430	190	165000	1737	132.5	120	103	321	M20	90	14	490	225	82	
	200	185000	1850											
	210	204000	1943											

● Sizes of clamping elements available from stock.
Other sizes on request.

CLAMPEX® – KTR 603

d x D [mm]	Shaft diameter d _w [mm]	Transmittable torque or axial force		Dimensions [mm]				Clamping screws DIN EN ISO 4014 - 10.9 μ _{total} =0.10				Surface pressure of clamping element/hollow shaft	Weight [-kg]	Stock programme	
		T [Nm]	F _{ax} [kN]	B	B ₁	B ₂	d ₁	M	Length	z = number	T _A [Nm]	P _H [N/mm ²]			
280 x 460	210	216000	2057												
	220	245000	2227	146.5	134	114	346	M20	100	16	490	217	102		
	230	270000	2348												
300 x 485	230	274000	2383												
	240	296000	2467	154.5	142	122	364	M20	100	18	490	209	118		
	245	316000	2580												
320 x 520	240	311000	2592												
	250	340000	2720	154.5	142	122	386	M20	100	20	490	219	131		
	260	375000	2885												
NEW 330 x 520	250	352000	2816												
	260	385000	2962	154.5	142	122	386	M20	100	22	490	224	126.1		
	270	420000	3111												
340 x 570	250	389000	3112												
	260	422000	3246	168.5	156	134	408	M20	110	24	490	227	186		
	270	459000	3400												
NEW 350 x 580	270	443000	3281												
	280	480000	3429	174.5	162	140	432	M20	110	24	490	212	195		
	285	500000	3509												
360 x 590	280	462000	3300												
	290	500000	3448	174.5	162	140	432	M20	110	24	490	204	204		
	300	530000	3533												
NEW 380 x 645	290	570000	3931												
	300	610000	4067	183	168	144	458	M24	120	20	840	224	239		
	310	660000	4258												
NEW 390 x 660	300	625000	4167												
	310	670000	4323	183	168	144	468	M24	120	21	840	229	260		
	320	720000	4500												
NEW 400 x 680	315	671000	4260												
	320	695000	4344	183	168	144	480	M24	120	21	840	222	280		
	330	745000	4515												
NEW 420 x 690	330	782000	4739												
	340	841000	4947	203	188	164	504	M24	130	24	840	211	316		
	350	902000	5154												
NEW 440 x 750	340	805000	4735												
	350	861000	4920	217	202	177	527	M24	140	24	840	190	408		
	360	920000	5111												
NEW 460 x 770	360	1000000	5556												
	370	1073000	5800	217	202	177	547	M24	140	28	840	210	420		
	380	1141000	6005												
NEW 480 x 800	380	1175000	6184												
	390	1250000	6410	228	213	188	570	M24	140	30	840	206	505		
	400	1312000	6560												
NEW 500 x 850	400	1314000	6570												
	410	1382000	6741	230	213	188	590	M27	150	24	1250	205	575		
	420	1460000	6952												

● Sizes of clamping elements available from stock.
Other sizes on request.

CLAMPEX® KTR 620

Clamping elements

Two-part external clamping set for applications on hollow shafts

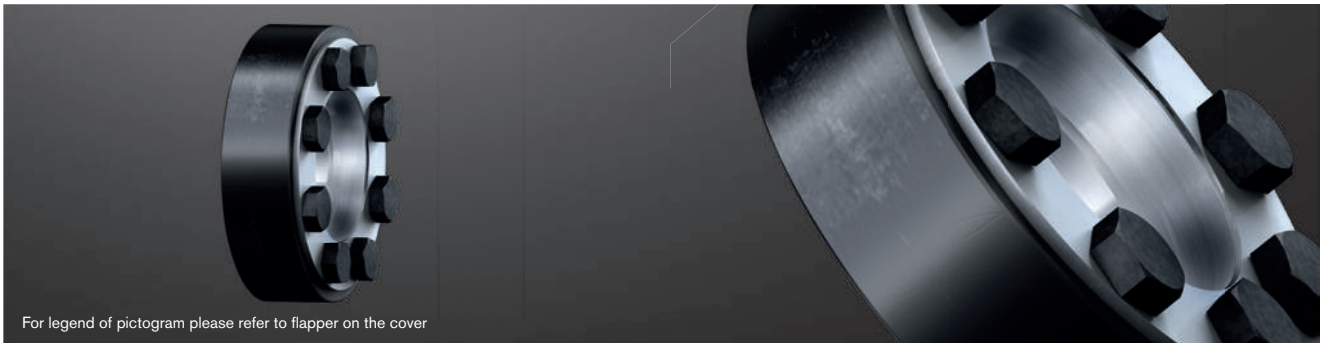

For legend of pictogram please refer to flapper on the cover

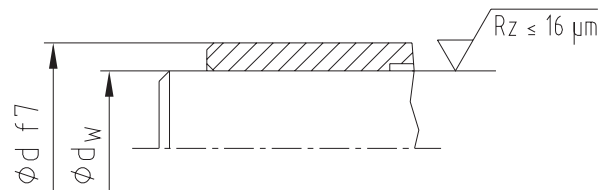
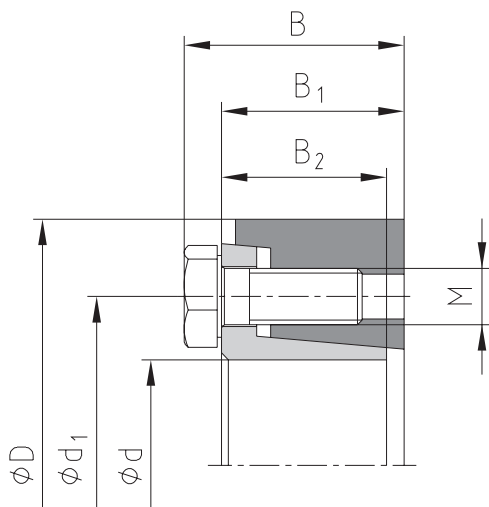

Tolerances for d_w

$$d_w \leq \varnothing 160 = h6/H7$$

$$d_w > \varnothing 160 = g6/H7$$

Bigger tolerances are generally possible! Please contact us!

Example of application of hub design

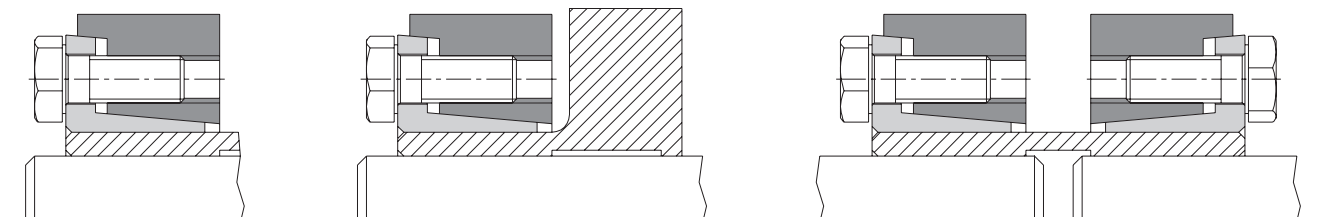

Ordering example:	KTR 620	55	x	100
	Series	Size of internal diameter d		Size of external diameter D

CLAMPEX® – KTR 620

d x D [mm]	Shaft diameter d _w [mm]	Transmittable torque or axial force		Dimensions [mm]				Clamping screws DIN EN ISO 4017 - 12.9 ¹⁾ μ _{total} =0.10				Surface pressure of clamping element/hollow shaft	Weight [-kg]	Stock programme
		T [Nm]	F _{ax} [kN]	B	B ₁	B ₂	d ₁	M	Length	z = number	T _A [Nm]	P _H [N/mm ²]		
NEW 16 x 41	13	70	11	19.5	15.3	13.5	28	M6	12	3	13	254	0.1	
	14	90	13											
NEW 18 x 44	15	80	11	19.5	15.3	13.5	30	M6	12	4	13	222	0.1	
	16	110	14											
20 x 47	17	150	18	19.5	15.3	13.5	32	M6	12	4	13	274	0.1	●
	18	175	19											
24 x 50	19	165	17	22	18.22	16	36	M6	16	5	13	243	0.2	●
	20	215	22											
NEW 26 x 51.5	22	280	25	22	18.05	16	38	M6	16	5	13	238	0.2	
	20	200	20											
30 x 60	22	260	24	24	20.26	18	44	M6	16	6	13	255	0.3	●
	24	330	28											
36 x 72	24	370	31	27.5	22.1	20	52	M8	20	5	30	250	0.5	●
	25	420	34											
38 x 72	26	465	36	27.5	22.1	20	54	M8	20	5	30	240	0.5	●
	27	480	36											
40 x 80	30	650	43	29.5	24.22	22	61	M8	20	6	30	209	0.6	●
	33	835	51											
44 x 80	27	480	36	29.5	24.22	22	61	M8	20	6	30	192	0.6	●
	34	830	49											
50 x 90	35	770	44	31.5	26.1	23.5	68	M8	20	8	30	212	0.8	●
	37	880	48											
55 x 100	38	1130	59	34.5	29	26	72	M8	20	8	30	195	1.1	●
	40	1260	63											
60 x 110	42	1400	67	34.5	29.25	26	80	M8	20	9	30	191	1.3	●
	42	1300	62											
62 x 110	45	1600	71	34.5	29.25	26	80	M8	20	9	30	189	1.3	●
	48	1900	79											
68 x 115	48	1700	71	35	29.4	26	86	M8	20	9	30	206	1.3	●
	50	1950	78											
75 x 138	52	2160	83	37.5	30.7	27	100	M10	25	10	60	211	2.3	●
	48	1700	71											
80 x 141	50	1950	78	37.5	31.1	27	104	M10	25	10	60	215	2.3	●
	52	2160	83											
NEW 85 x 155	55	2500	91	44.5	38.2	34	114	M10	25	11	60	216	3.2	
	60	3150	105											
90 x 155	55	2700	98	44.5	38.2	34	114	M10	25	11	60	223	3.2	●
	65	4100	126											
NEW 95 x 170	60	3400	113	50	43.45	39	124	M10	30	14	60	182	4.3	
	65	4100	126											
100 x 170	60	3300	110	50	43.45	39	124	M10	30	14	60	176	4.3	●
	70	4950	141											
NEW 105 x 185	65	5500	169	56.5	49.1	43.5	136	M12	35	12	100	208	5.8	
	70	6200	177											
110 x 185	70	6600	189	56.5	49.1	43.5	136	M12	35	12	100	202	5.8	●
	75	7900	211											
NEW 115 x 197	70	6200	177	60.5	53	48	147	M12	35	14	100	193	6.9	
	75	7400	197											
120 x 197	80	8600	215	60.5	53	48	147	M12	35	14	100	189	6.9	
	70	6200	177											
NEW 120 x 197	80	10500	263	60.5	53	48	147	M12	35	14	100	189	6.9	
	85	11800	278											
NEW 120 x 197	85	12500	294	60.5	53	48	147	M12	35	14	100	189	6.9	
	90	14100	313											
NEW 120 x 197	90	14100	313	60.5	53	48	147	M12	35	14	100	189	6.9	
	95	16000	337											
NEW 120 x 197	85	12500	294	60.5	53	48	147	M12	35	14	100	189	6.9	
	95	16000	337											

● Sizes of clamping elements available from stock.
¹⁾ DIN EN ISO 4017-10.9 for size 16 x 41 to 20 x 47

CLAMPEX® KTR 620

Clamping elements

Two-part external clamping set for applications on hollow shafts

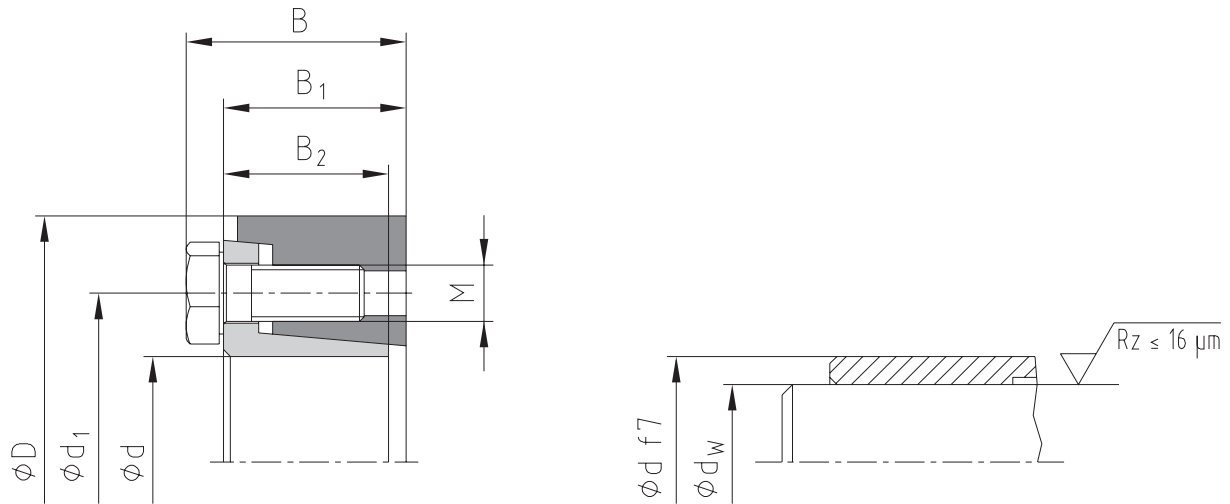

CLAMPEX® – KTR 620

d x D [mm]	Shaft diameter d _w [mm]	Transmittable torque or axial force		Dimensions [mm]				Clamping screws DIN EN ISO 4017 - 12.9 μ _{total} =0.10				Surface pressure of clamping element/hollow shaft		Weight [-kg]	Stock programme
		T [Nm]	F _{ax} [kN]	B	B ₁	B ₂	d ₁	M	Length	z = number	T _A [Nm]	P _H [N/mm ²]			
125 x 215	90	14500	322	61	53.4	48	158	M12	35	14	100	196	8.7	●	
	95	16600	349												
	100	18800	376												
NEW 130 x 215	95	17000	358	61	53.4	48	158	M12	35	14	100	187	9.4		
	100	18400	368												
	110	22000	400												
130 x 230	95	18400	387	66.5	57.5	51	165	M14	40	12	160	213	10.8	●	
	100	20800	416												
	110	26200	476												
NEW 135x 230	95	18400	387	66.5	57.5	51	165	M14	40	12	160	209	10.8		
	100	20800	416												
	110	26200	476												
140 x 230	100	19900	398	67	57.8	51	172	M14	40	12	160	207	10.3		
	105	22200	423												
	115	27800	483												
NEW 150 x 263	110	27000	491	71	62.2	55	186	M14	40	14	160	202	15.2		
	120	32000	533												
	125	36200	579												
155 x 263	110	27000	491	71	62.2	55	186	M14	40	14	160	199	15.2		
	120	32000	533												
	125	36200	579												
NEW 160 x 290	120	39000	650	78.5	68.5	61	198	M16	45	12	250	215	21.5		
	130	48000	738												
	135	51000	756												
165 x 290	120	39000	650	78.5	68.5	61	198	M16	45	12	250	212	21.5		
	130	48000	738												
	135	51000	756												
NEW 170 x 300	130	46500	715	79	68.9	61	208	M16	50	14	250	212	22.5		
	140	53000	757												
	145	59000	814												
175 x 300	130	46500	715	79	68.9	61	208	M16	50	14	250	209	22.5	●	
	140	53000	757												
	145	59000	814												
NEW 180 x 320	140	66000	943	95	85	77.5	222	M16	50	16	250	210	32.7		
	150	76000	1013												
	155	83000	1071												
185 x 320	140	66000	943	95	85	77.5	222	M16	50	16	250	207	32.7		
	150	76000	1013												
	155	83000	1071												
NEW 190 x 340	150	82000	1093	98	87.7	77.5	238	M16	50	16	250	225	36.3		
	160	91000	1138												
	165	102000	1236												
NEW 195 x 340	150	82000	1093	98	87.7	77.5	238	M16	50	16	250	222	36.3		
	160	91000	1138												
	165	102000	1236												
200 x 340	150	82000	1093	98	87.7	77.5	238	M16	50	16	250	219	36.3		
	160	91000	1138												
	165	102000	1236												

● Sizes of clamping elements available from stock.

CLAMPEX® – KTR 620

d x D [mm]	Shaft diameter d _w [mm]	Transmittable torque or axial force		Dimensions [mm]				Clamping screws DIN EN ISO 4017 - 12.9 ²⁾ μ _{total} =0.10				Surface pressure of clamping element/hollow shaft		Weight [-kg]	Stock programme
		T [Nm]	F _{ax} [kN]	B	B ₁	B ₂	d ₁	M	Length	z = number	T _A [Nm]	P _H [N/mm ²]			
220 x 370	160	105000	1313	120	107.55	96.5	268	M20	60	15	480	205	53		
	170	122000	1435												
	180	138000	1533												
240 x 405	170	125000	1471	123.5	111.1	98	288	M20	60	16	480	214	66		
	180	145000	1611												
	200	182000	1820												
260 x 430	190	165000	1737	138	125.3	110.5	312	M20	60	16	480	202	82		
	200	190000	1900												
	220	238000	2164												
280 x 460	210	220000	2095	152.5	140	121	334	M20	60	18	480	193	103		
	220	245000	2227												
	240	300000	2500												
300 x 485	220	297000	2700	159	139.8	124	360	M24	70	16	840	205	120		
	230	330000	2870												
	250	399000	3192												
320 x 520	240	331000	2758	160.5	141.6	124	380	M24	70	18	840	190	138		
	250	365000	2920												
	270	437000	3237												
340 x 570	250	429000	3432	177.5	158.4	139	402	M24	70	18	840	195	189		
	260	469000	3608												
	280	556000	3971												
360 x 590	270	545000	4037	182	163	143	424	M24	70	20	840	216	207		
	280	592000	4229												
	290	694000	4786												
NEW 390 x 650	290	704000	4855	191	169.2	148	454	M27	70	18	1250	216	249		
	300	760000	5067												
	320	879000	5494												
NEW 420 x 670	320	827000	5169	208.4	186.4	166	486	M27	70	20	1250	184	285		
	330	876000	5309												
	350	1000000	5714												
NEW 440 x 710	340	1117000	6571	220	198	179	506	M27	70	21	1250	222	343		
	350	1190000	6800												
	370	1345000	7270												
NEW 460 x 750	360	1306000	7256	223	201	179	534	M27	70	21	1250	230	387		
	370	1386000	7492												
	390	1554000	7969												
NEW 470 x 705	370	950000	5135	241.6	219.6	200	538	M27	70	21	1250	151	340		
	380	1000000	5263												
	400	1150000	5750												
NEW 480 x 770	380	1557000	8195	247	223	201	552	M30	100	21	1650	223	449		
	390	1648000	8451												
	410	1818000	8868												
NEW 500 x 820	400	1653000	8265	241	217	198	572	M30	100	24	1650	214	515		
	410	1725000	8415												
	430	1915000	8907												
NEW 530 x 850	430	2048000	9526	262.3	238.3	216	606.5	M30	100	24	1650	208	585		
	440	2154000	9791												
	460	2374000	10322												
NEW 560 x 885	450	2306000	10249	266	242	220	632	M30	100	24	1650	212	636		
	460	2419000	10517												
	480	2654000	11058												
NEW 590 x 950	470	2735000	11638	281.5	257.5	236	664	M30	100	28	1650	211	805		
	480	2863000	11929												
	500	3128000	12512												
NEW 620 x 960	500	3150000	12600	307	283	258	706	M30	100	28	1650	201	853		
	520	3396000	13062												
	540	3689000	13663												
NEW 660 x 1020	530	3636000	13721	319	293	267	748	M33	130	28	2250	199	993		
	550	3942000	14335												
	570	4261000	14951												
NEW 700 x 1085	560	4189000	14961	318.5	292.5	263	788	M33	130	28	2250	187	1112		
	580	4520000	15586												
	600	4863000	16210												
NEW 750 x 1100	600	5281000	17603	346	320	280	850	M33	130	32	2250	202	1111		
	620	5672000	18297												
	650	6287000	19345												
NEW 800 x 1230	640	6091000	19034	359	333	296	900	M33	130	32	2250	202	1589		
	660	6511000	19730												
	700	7394000	21126												

● Sizes of clamping elements available from stock.
²⁾ DIN EN ISO 4014-12.9 for size 660 x 1020 to 800 x 1230

CLAMPEX® KTR 700

Clamping elements

Rigid shaft coupling to connect two shaft ends

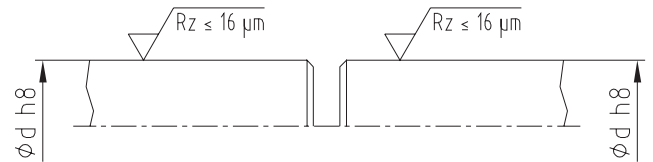
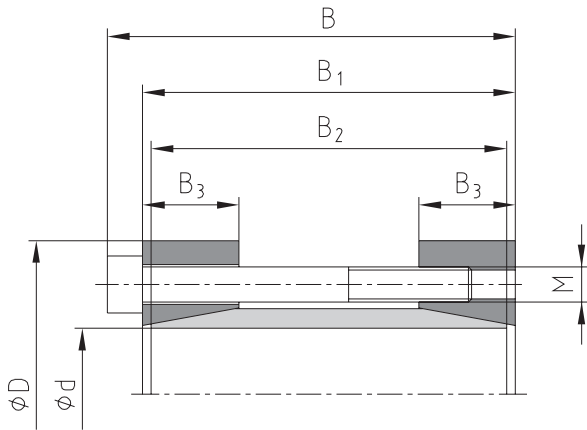
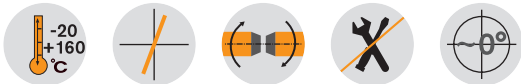
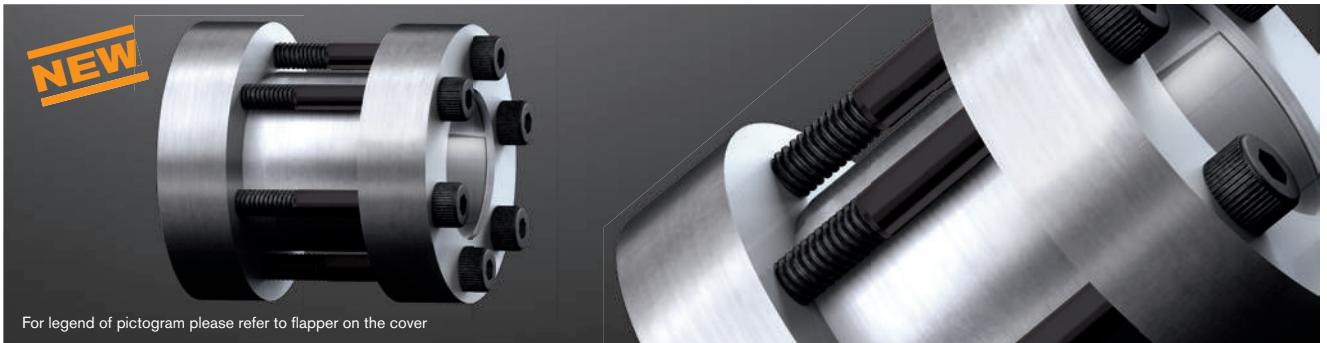

Example of application

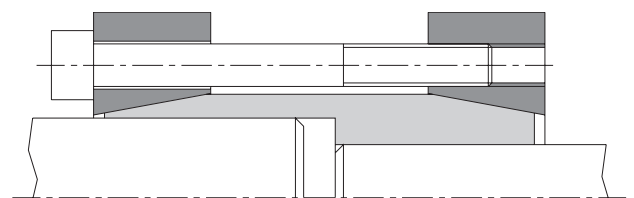
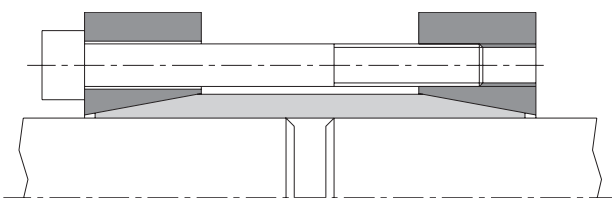

Type on request

Ordering example:	KTR 700	35	x	75
	Series	Size of internal diameter d		Size of external diameter D

CLAMPEX® – KTR 700														
d x D [mm]	Dimensions [mm]				Clamping screws DIN EN ISO 4762 - 12.9 $\mu_{\text{total}}=0.14$				Transmittable torque or axial force			Surface pressure of clamping element/ shaft	Weight [~kg]	Stock programme
	B	B ₁	B ₂	B ₃	M	Length	z = number	T _A [Nm]	T [Nm]	F _{ax} [kN]	P _{VV} [N/mm ²]			
10 x 35	42	38	36	15	M4	30	6	5.5	62	12	219	0.2		
11 x 35	42	38	36	15	M4	30	6	5.5	66	12	193	0.2		
12 x 35	42	38	36	15	M4	30	6	5.5	72	12	177	0.2		
14 x 35	42	38	36	15	M4	30	6	5	76	11	137	0.2		
15 x 45	56	50	47	15	M6	45	4	17	160	21	252	0.4		
16 x 45	56	50	47	15	M6	45	4	17	170	21	235	0.4		
17 x 45	56	50	47	15	M6	45	4	17	180	21	220	0.4	●	
18 x 50	56	50	47	15	M6	45	4	17	190	21	207	0.5		
19 x 50	56	50	47	15	M6	45	4	17	200	21	196	0.4		
20 x 50	56	50	47	15	M6	45	4	17	220	22	195	0.4	●	
22 x 55	66	60	57	18	M6	55	6	17	360	33	219	0.5		
24 x 55	66	60	57	18	M6	55	6	17	390	33	200	0.6		
25 x 55	66	60	57	18	M6	55	6	17	400	32	189	0.6	●	
28 x 60	66	60	57	18	M6	55	6	17	390	28	147	0.8		
30 x 60	66	60	57	18	M6	55	6	17	420	28	138	0.7	●	
32 x 75	83	75	72	20	M8	70	4	41	610	38	158	0.1		
35 x 75	83	75	72	20	M8	70	4	41	670	38	145	1.3	●	
38 x 75	83	75	72	20	M8	70	4	41	730	38	134	1.2		
40 x 75	83	75	72	20	M8	70	4	41	760	38	126	1.2	●	
42 x 85	93	85	81	22	M8	80	6	41	1170	56	160	1.8		
45 x 85	93	85	81	22	M8	80	6	41	1260	56	150	1.7		
48 x 90	93	85	81	22	M8	80	6	41	1360	57	142	1.9		
50 x 90	93	85	81	22	M8	80	6	41	1400	56	135	1.8	●	
55 x 95	93	85	81	22	M8	80	8	41	2000	73	159	2.0		
60 x 100	93	85	81	22	M8	80	8	41	2260	75	151	2.2	●	
65 x 105	93	85	81	22	M8	80	8	41	2500	77	143	2.6		
70 x 115	110	100	96	35	M10	80	8	83	3300	94	102	4.1		
75 x 120	110	100	96	35	M10	80	8	83	3500	93	94	4.3		
80 x 125	110	100	96	35	M10	80	7	75	3900	98	92	4.5		
90 x 136	110	100	96	35	M10	80	8	75	5100	113	95	5.2		
100 x 158	132	120	116	40	M12	100	8	130	8350	167	111	6.0		

● Sizes of clamping elements available from stock.

KTR Clamping nuts

Large screw connections for easy and quick assembly

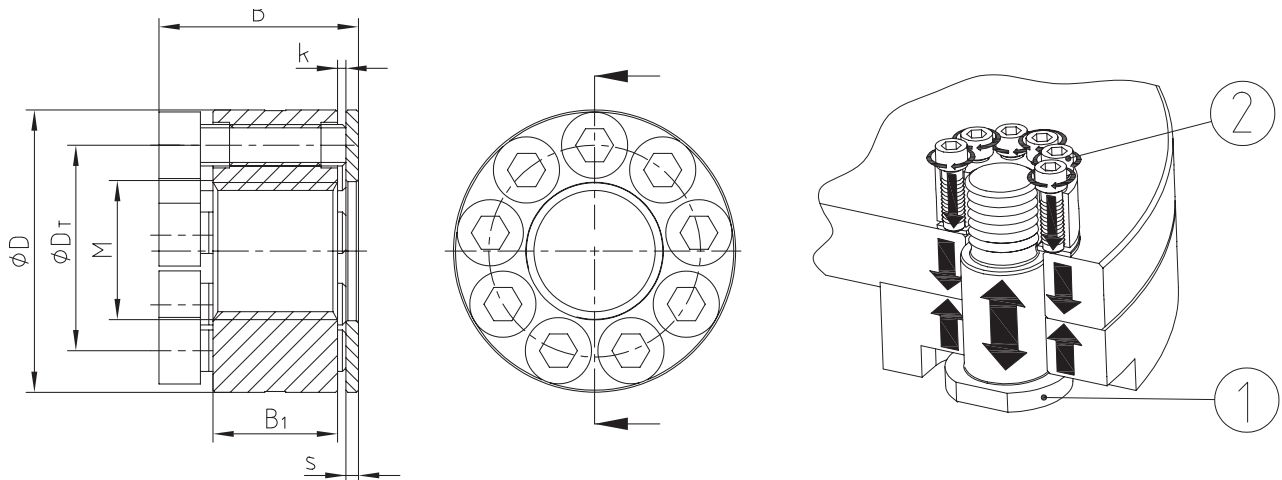
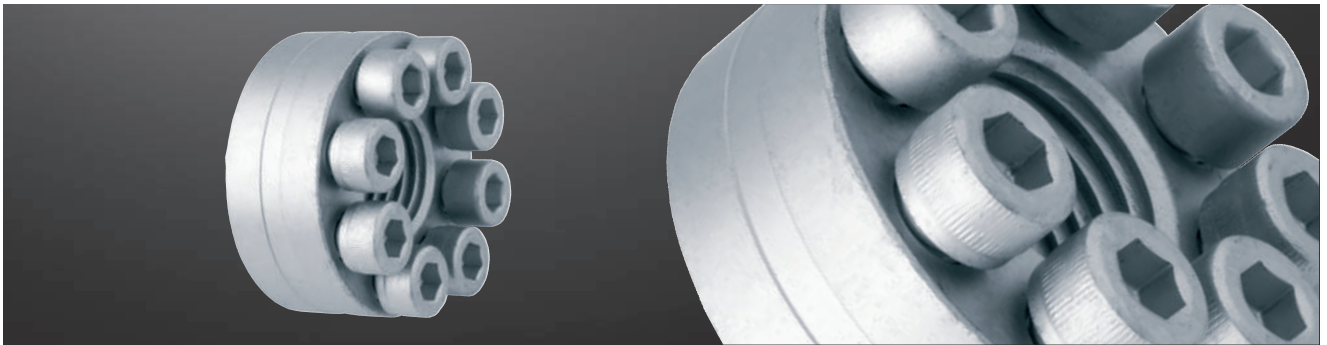

KTR Clamping nuts													
Size	Dimensions [mm]						Pressure screw pos. 2		Property class 8.8, screw pos. 1		Property class 10.9, screw pos. 1		
	D	D _T	B	B ₁	s	k	DIN EN ISO 4762	z = number	Tightening torque* [Nm]	Preload force [N]	Tightening torque* [Nm]	Preload force [N]	
M24 x 3.0	52	39	36.0	20	3.0	1 - 2	M8	8	21	174000	30	249000	
M27 x 3.0	57	42	41.0	25	3.0	1 - 2	M8	9	24	224000	30	280000	
M30 x 3.5	65	48	43.0	25	3.0	1 - 2	M10	8	41	274000	60	401000	
M33 x 3.5	68	51	48.0	30	3.0	1 - 2	M10	9	45	338000	60	451000	
M36 x 4.0	80	58	50.0	30	3.0	1 - 2	M12	8	71	396000	105	586000	
M42 x 4.5	86	64	55.0	35	3.0	1 - 2	M12	10	78	544000	105	732000	
M48 x 5.0	90	72	60.0	40	3.0	1 - 2	M12	11	94	721000	105	806000	
M52 x 5.0	100	79	66.5	42	4.5	1 - 2	M12	13	95	862000	105	952000	
M56 x 5.5	108	83	75.5	45	4.5	1 - 2	M16	9	210	1001000	250	1192000	
M60 x 5.5	112	86	80.5	48	4.5	1 - 2	M16	10	215	1139000	250	1325000	
M64 x 6.0	120	92	84.0	52	8.0	1 - 2	M16	11	225	1311000	250	1457000	
M72 x 6.0	142	107	98.0	58	8.0	1 - 2	M20	10	400	1696000	490	2077000	
M80 x 6.0	164	122	103.0	64	8.0	1 - 2	M20	12	420	2137000	490	2493000	

* each screw pos. 2

Ordering example:	KTR clamping nut	M33 x 3.5
	Designation	Size

Used on 100 kNm test bench flanges

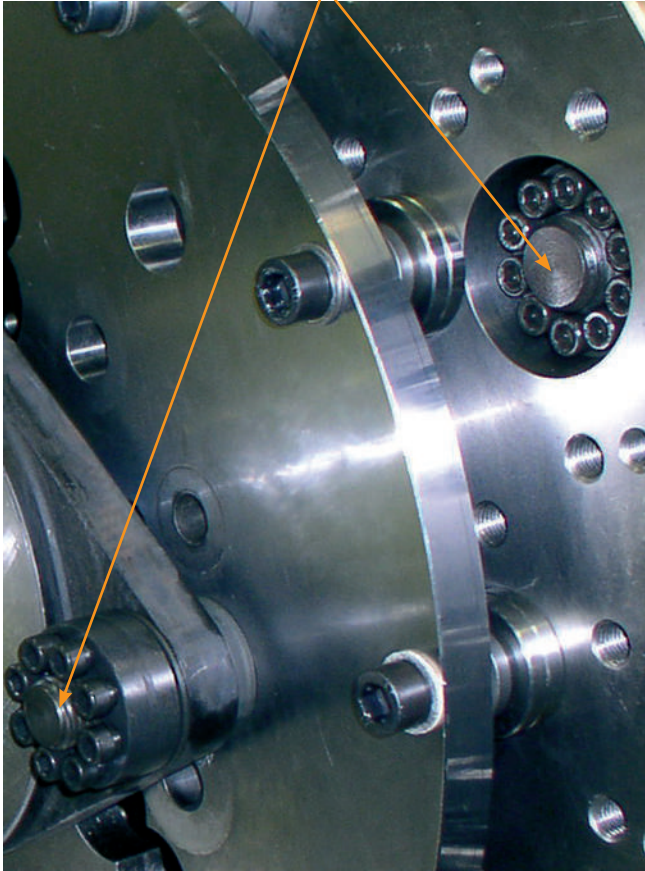

Used on couplings for wind power stations

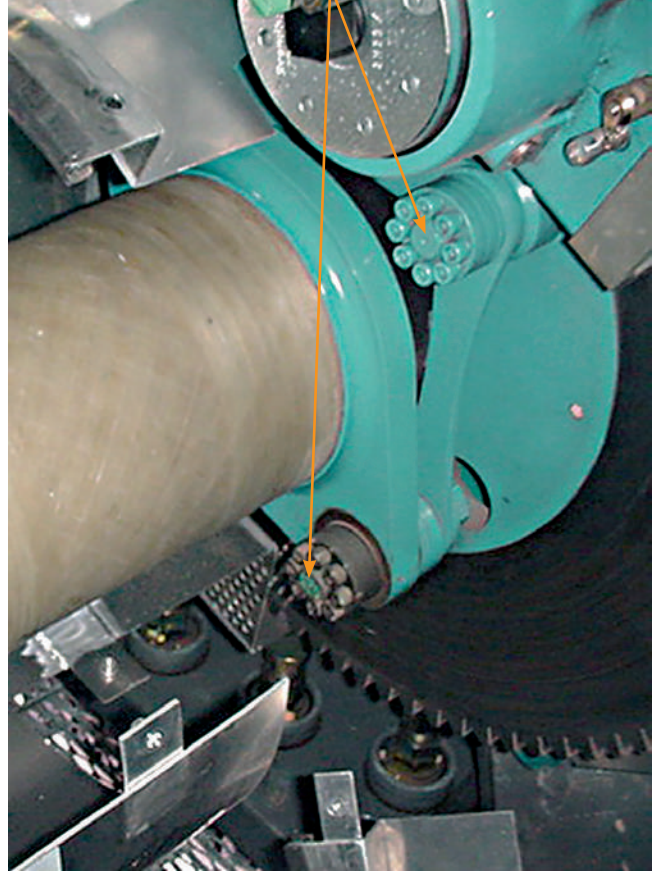

Available as a complete unit including
dowel screw

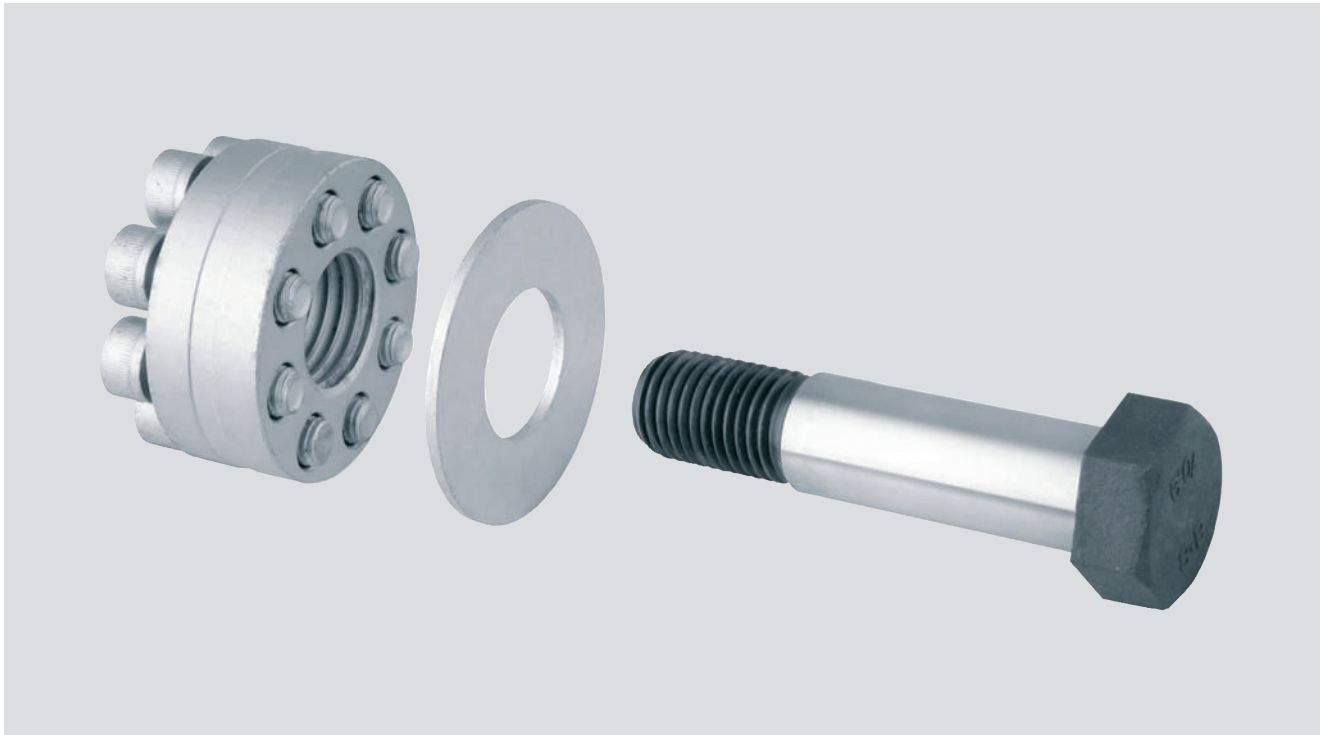

Selection and sizing according to DIN 808 with plain/needle bearing

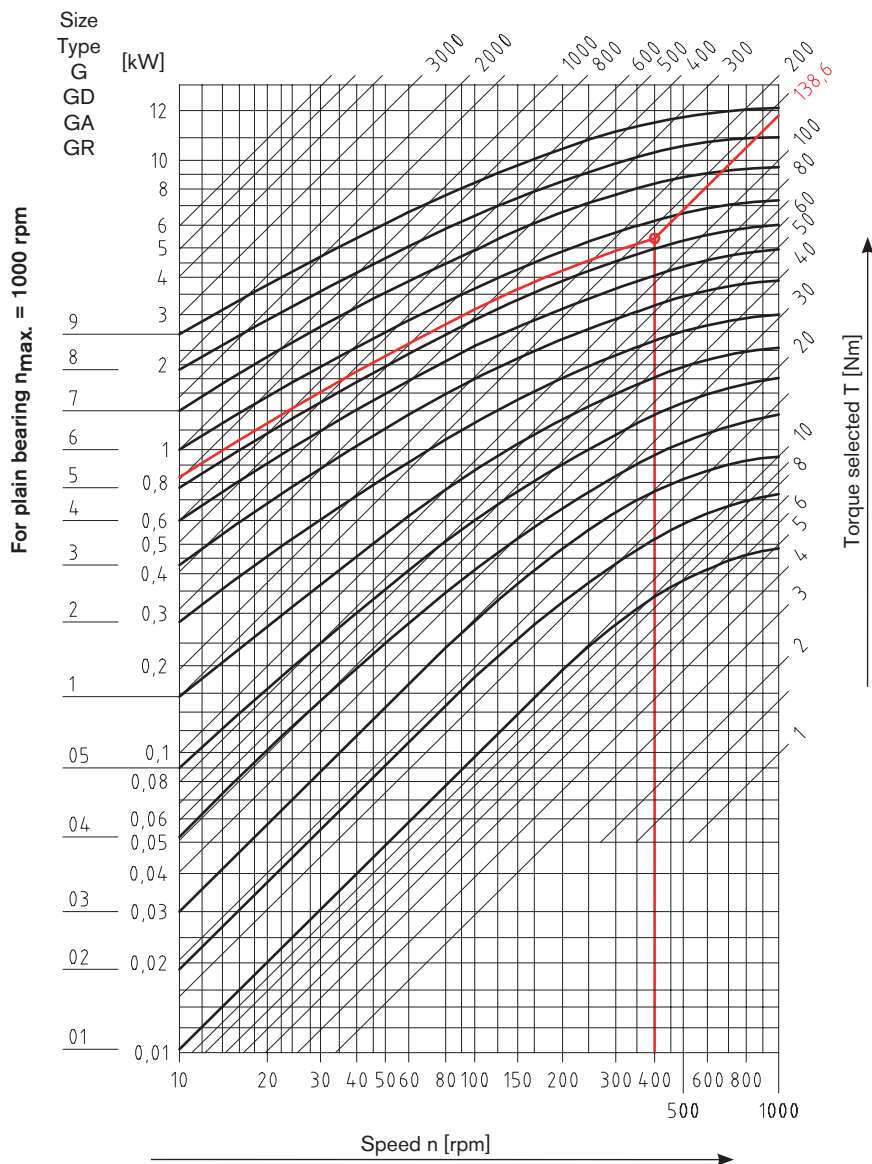

Selection of type G, GD, GA, GR (max. 1000 rpm) ¹⁾

The selection of precision joints with plain bearing is based on the driving torque considering a correction value which depends on the diffraction angle α and the operating speed.

For extendable joints the overall length and the speed need to be additionally considered for sizing (please consult with KTR).

$$\text{Driving torque } M_t \text{ [Nm]} = 9550 \cdot \frac{\text{Power [kW]}}{\text{Speed [rpm]}}$$

$$\text{Torque selected } T \text{ [Nm]} = \text{driving torque} \cdot \text{correction value}$$

Additional review:

$$\text{Diffraction angle } [\alpha] \cdot \text{speed [rpm]} \leq 40,000$$

Diffraction angle $[\alpha]$	5°	10°	15°	20°	25°	30°	35°	40°	45°
Correction value	0.8	1.00	1.25	1.5	1.8	2.2	2.6	3.3	4.0

Details given:

Driving torque M_t 63 Nm
 Diffraction angle 30° → Correction value for diffraction angle 2.2
 Operating speed 400 rpm

$$\text{Torque selected } T \text{ [Nm]} = 63 \text{ Nm} \cdot 2.2 \rightarrow 138.6 \text{ Nm}$$

Selection based on table: [joint size 6](#)

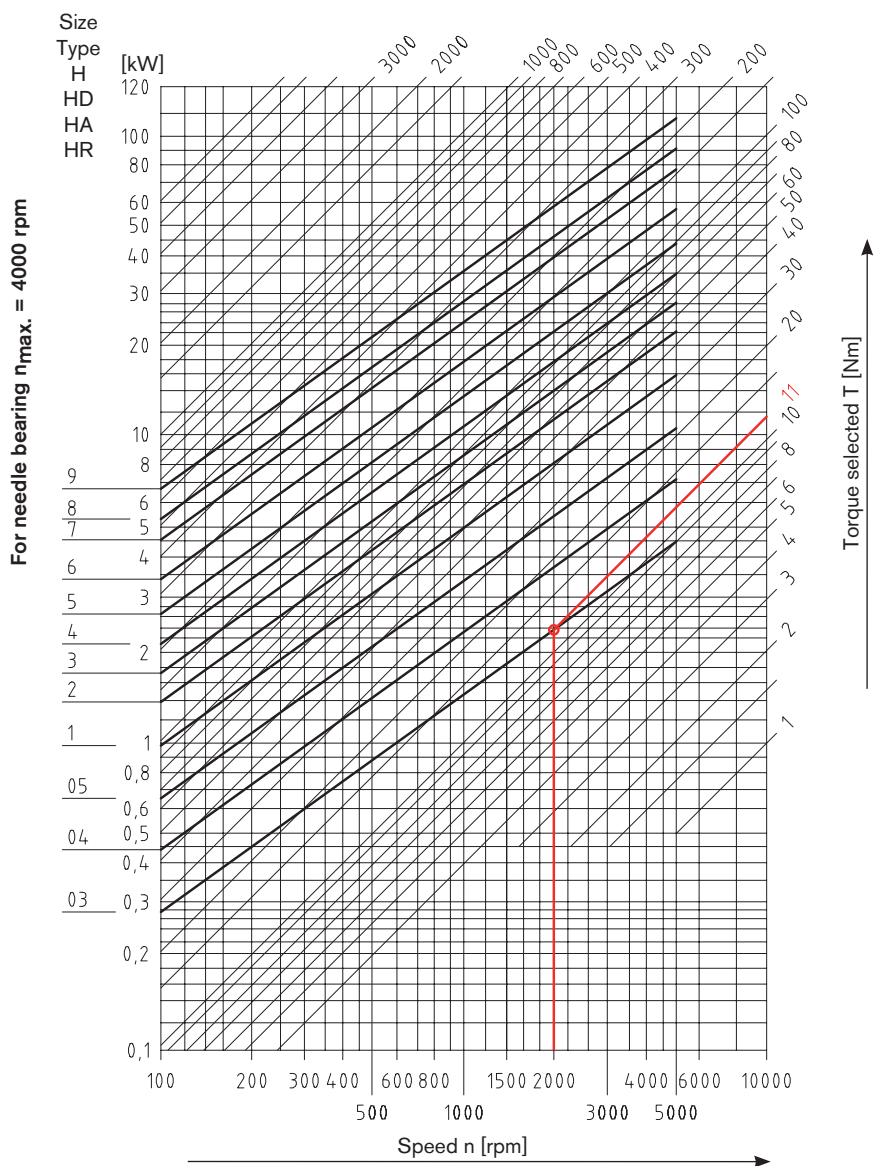

CLAMPEX®

Clamping nuts

Selection of type H, HD, HA, HR (max. 4000 rpm) ¹⁾

The selection of precision joints with needle bearing is based on the driving torque considering a correction value which depends on the diffraction angle α and the operating speed.

For extendable joints the overall length and the speed need to be additionally considered for sizing (please consult with KTR).

$$\text{Driving torque } M_t \text{ [Nm]} = 9550 \cdot \frac{\text{Power [kW]}}{\text{Speed [rpm]}}$$

$$\text{Torque selected } T \text{ [Nm]} = \text{driving torque} \cdot \text{correction value}$$

Additional review:

$$\text{¹⁾ Diffraction angle } [\alpha] \cdot \text{speed [rpm]} \leq 40,000$$

Diffraction angle $[\alpha]$	5°	10°	15°	20°	25°	30°	35°	40°	45°
Correction value	0.8	1.00	1.1	1.25	1.4	2.0	2.5	3.3	4.0

Details given:

Driving torque M_t

8.8 Nm

Diffraction angle

20°

→ Correction value for diffraction angle 1.25

Operating speed

2000 rpm

$$\text{Torque selected } T \text{ [Nm]} = 8.8 \text{ Nm} \cdot 1.25 \rightarrow 11 \text{ Nm}$$

Selection based on table: [joint size 03](#)

KTR Precision joints

Clamping sets

KTR Precision joints type G and GD

According to DIN 808 with plain bearing



For legend of pictogram please refer to flapper on the cover



Precision single joint G

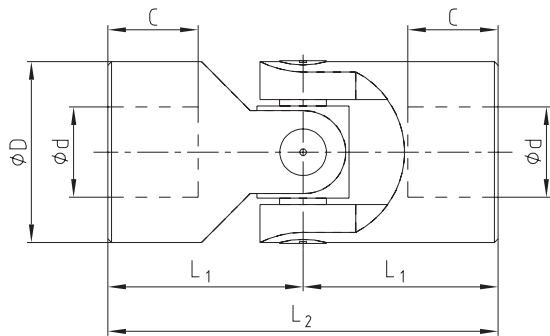

Precision double joint GD

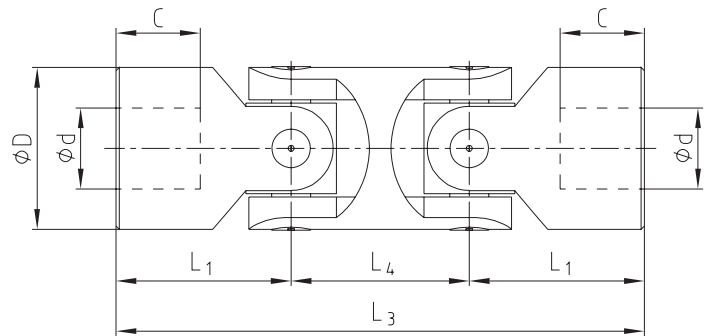

Finish bores:

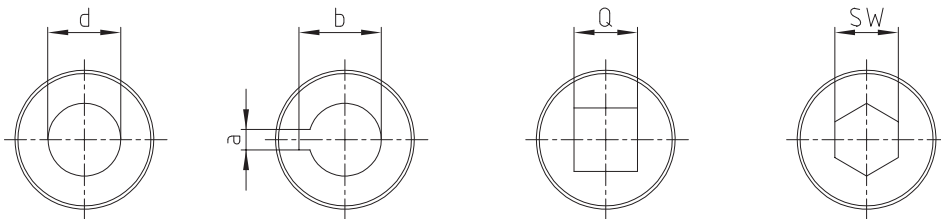

Type G and GD																
Types and size															Weight [kg]	
Size G	DIN designation G	Size GD	DIN designation GD	d (H7)	D	L ₂	L ₁	C	L ₄	L ₃	a (JS9)	b	Q (H10)	SW (H10)	G	GD
01 G	E6 x 16-G	01 GD	D6 x 16-G	6	16	34	17	8	22	56	2	7.0	6	6	0.05	0.08
02 G	E8 x 16-G	02 GD	D8 x 16-G	8	16	40	20	11	22	62	2	9.0	8	8	0.05	0.08
03 G	E10 x 22-G	03 GD	D10 x 22-G	10	22	48	24	12	26	74	3	11.4	10	10	0.10	0.15
04 G	E12 x 25-G	04 GD	D12 x 25-G	12	25	56	28	13	30	86	4	13.8	12	12	0.16	0.25
05 G	E14 x 28-G	05 GD	D14 x 28-G	14	28	60	30	14	36	96	5	16.3	14	14	0.20	0.40
1 G	E16 x 32-G	1 GD	D16 x 32-G	16	32	68	34	16	37	105	5	18.3	16	16	0.30	0.45
2 G	E18 x 36-G	2 GD	D18 x 36-G	18	36	74	37	17	40	114	6	20.8	18	18	0.45	0.70
3 G	E20 x 42-G	3 GD	D20 x 42-G	20	42	82	41	18	47	129	6	22.8	20	20	0.60	1.00
4 G	E22 x 45-G	4 GD	D22 x 45-G	22	45	95	47.5	22	50	145	6	24.8	22	22	0.95	1.55
5 G	E25 x 50-G	5 GD	D25 x 50-G	25	50	108	54	26	55	163	8	28.3	25	25	1.20	2.00
6 G	E30 x 58-G	6 GD	D30 x 58-G	30	58	122	61	29	68	190	8	33.3	30	30	1.85	2.90
6 G1	E32 x 58-G	6 GD1	D32 x 58-G	32	58	130	65	33	68	198	10	35.3	30	30	2.00	3.00
7 G	E35 x 70-G	7 GD	D35 x 70-G	35	70	140	70	33	72	212	10	38.3	-	-	3.15	4.75
8 G	E40 x 80-G	8 GD	D40 x 80-G	40	80	160	80	38	85	245	12	43.3	-	-	4.60	7.20
9 G	E50 x 95-G	9 GD	D50 x 95-G	50	95	190	95	46	100	290	14	53.8	-	-	7.60	12.0

Ordering example:	04 G	Ø12	Ø12 keyway to DIN
	Size and type of joint	Finish bore (H7)	Finish bore (H7), feather keyway acc. to DIN 6885 sheet 1 (JS9)

KTR Precision joints type H and HD

According to DIN 808 with needle bearing



For legend of pictogram please refer to flapper on the cover



Precision single joint H

Precision double joint HD

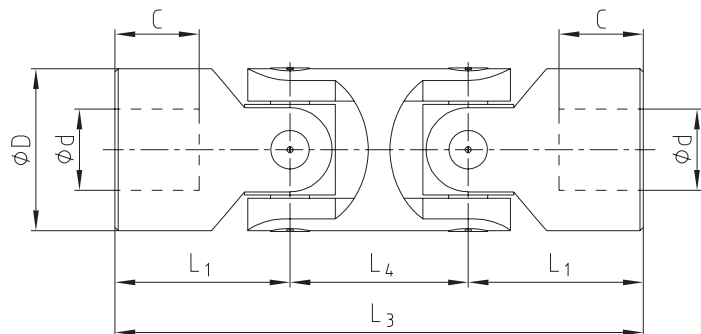
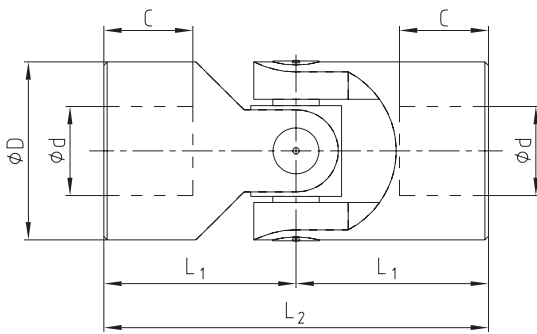

Finish bores:

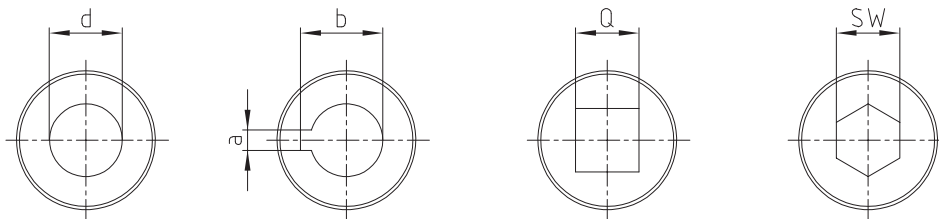

Type H and HD																
Types and size				Dimensions [mm]										Weight [kg]		
Size H	DIN designation H	Size HD	DIN designation HD	d (H7)	D	L ₂	L ₁	C	L ₄	L ₃	a (JS9)	b	Q (H10)	SW (H10)	H	HD
03 H	E10 x 22-W	03 HD	D10 x 22-W	10	22	48	24	12	26	74	3	11.4	10	10	0.10	0.15
04 H	E12 x 25-W	04 HD	D12 x 25-W	12	25	56	28	13	30	86	4	13.8	12	12	0.16	0.25
05 H	E14 x 28-W	05 HD	D14 x 28-W	14	28	60	30	14	36	96	5	16.3	14	14	0.20	0.40
1 H	E16 x 32-W	1 HD	D16 x 32-W	16	32	68	34	16	37	105	5	18.3	16	16	0.30	0.45
2 H	E18 x 36-W	2 HD	D18 x 36-W	18	36	74	37	17	40	114	6	20.8	18	18	0.45	0.70
3 H	E20 x 42-W	3 HD	D20 x 42-W	20	42	82	41	18	47	129	6	22.8	20	20	0.60	1.00
4 H	E22 x 45-W	4 HD	D22 x 45-W	22	45	95	47.5	22	50	145	6	24.8	22	22	0.95	1.55
5 H	E25 x 50-W	5 HD	D25 x 50-W	25	50	108	54	26	55	163	8	28.3	25	25	1.20	2.00
6 H	E30 x 58-W	6 HD	D30 x 58-W	30	58	122	61	29	68	190	8	33.3	30	30	1.85	2.90
6 H1	E32 x 58-W	6 HD1	D32 x 58-W	32	58	130	65	33	68	198	10	35.3	30	30	2.00	3.00
7 H	E35 x 70-W	7 HD	D35 x 70-W	35	70	140	70	33	72	212	10	38.3	-	-	3.15	4.75
8 H	E40 x 80-W	8 HD	D40 x 80-W	40	80	160	80	38	85	245	12	43.3	-	-	4.60	7.20
9 H	E50 x 95-W	9 HD	D50 x 95-W	50	95	190	95	46	100	290	14	53.8	-	-	7.60	12.0

Ordering example:	1 H	Ø16	Ø16 keyway to DIN
	Size and type of joint	Finish bore (H7)	Finish bore (H7), feather keyway acc. to DIN 6885 sheet 1 (JS9)

KTR Precision joints type GA and HA

According to DIN 808 with plain and needle bearing (extendable)

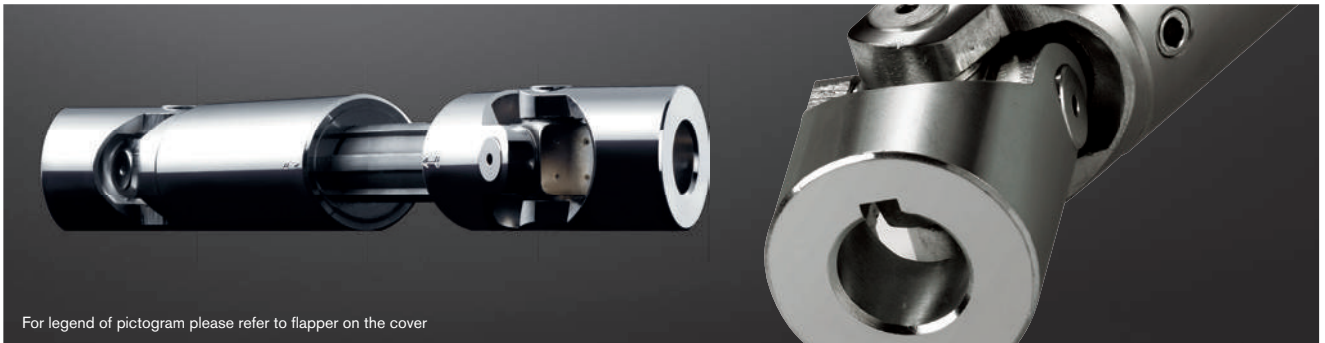

For legend of pictogram please refer to flapper on the cover

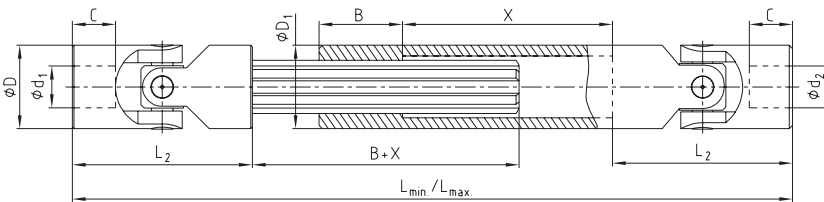
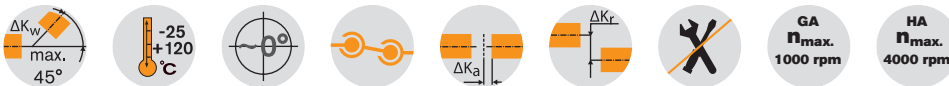

Preferred lengths									
Size	Dimensions [mm]								
	L _{min.} / L _{max.}								
03	140	160	180	230					
	170	200	240	330					
04	160	180	200	220	250	280	300		
	190	225	270	300	355	420	450		
05	170	180	200	220	250	280	300	350	400
	200	220	260	300	350	420	450	550	650
1	190	210	240	250	275	300	380	400	
	220	250	320	350	390	430	590	630	
2	230	250	270	290	300	400	500		
	280	320	370	400	415	620	820		
3	250	270	290	320	380	420	500		
	300	340	380	440	560	640	800		
4	250	270	290	330	350	470			
	280	320	350	430	470	710			
5	295	310	350	380	420	460	500		
	345	375	450	500	590	660	745		
6	330	350	370	400	450	500	540		
	380	420	455	510	620	720	795		

Finish bores:

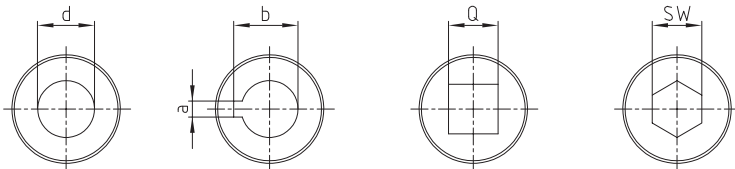

Type GA with plain bearing n _{max.} = 1000 rpm and type HA with needle bearing n _{max.} = 4000 rpm													
Size		Dimensions [mm]										Splines shaft	D ₁
GA	HA	d ₁ , d ₂ (H7)	D	L ₂	C	L _{min.} / L _{max.} / X	B	a (JS9)	b	Q (H10)	SW (H10)		
01 GA	-	6	16	34	8	← →	25	2	7.0	6	6	SW8	16
02 GA	-	8	16	40	11	← →	25	2	9.0	8	8	SW8	16
03 GA	03 HA	10	22	48	12	← →	30	3	11.4	10	10	11 x 14 Z6	22
04 GA	04 HA	12	25	56	13	← →	40	4	13.8	12	12	13 x 16 Z6	26
05 GA	05 HA	14	28	60	14	← →	40	5	16.3	14	14	13 x 16 Z6	29
1 GA	1 HA	16	32	68	16	← →	40	5	18.3	16	16	16 x 20 Z6	32
2 GA	2 HA	18	36	74	17	← →	40	6	20.8	18	18	18 x 22 Z6	37
3 GA	3 HA	20	42	82	18	← →	45	6	22.8	20	20	21 x 25 Z6	42
4 GA	4 HA	22	45	95	22	← →	45	6	24.8	22	22	23 x 28 Z6	47
5 GA	5 HA	25	50	108	26	← →	45	8	28.3	25	25	26 x 32 Z6	52
6 GA	6 HA	30	58	122	29	← →	50	8	33.3	30	30	32 x 38 Z8	58
7 GA	7 HA	35	70	140	33	← →	70	10	38.3	-	-	36 x 42 Z8	70
8 GA	8 HA	40	80	160	38	← →	80	12	43.3	-	-	42 x 48 Z8	80
9 GA	9 HA	50	95	190	46	← →	90	14	53.8	-	-	46 x 54 Z8	95

Calculation of mounting lengths L and X (stroke)

$$\text{Stroke } X \geq \frac{L_{\max.} - 2 \cdot L_2 - B}{2}$$

$$L_{\min.} \geq \frac{L_{\max.} + 2 \cdot L_2 + B}{2}$$

$$\text{Minimum size } L_{\min.} = L_2 + B + X + L_2$$

Ordering example:	3 GA	d ₁ = Ø20	d ₂ = Ø20 keyway to DIN	550/650
	Size and type of joint	Finish bore (H7)	Finish bore (H7), feather keyway acc. to DIN 6885 sheet 1 (JS9)	Mounting length L _{min.} /L _{max.}

KTR Precision joints type X and XD

According to DIN 808 with plain bearing made of stainless steel 1.4301

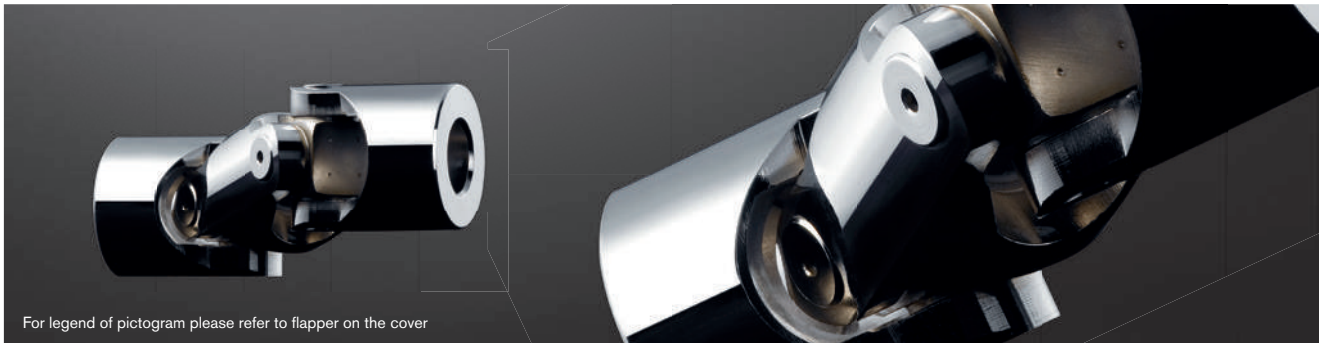

For legend of pictogram please refer to flapper on the cover



Precision single joint X

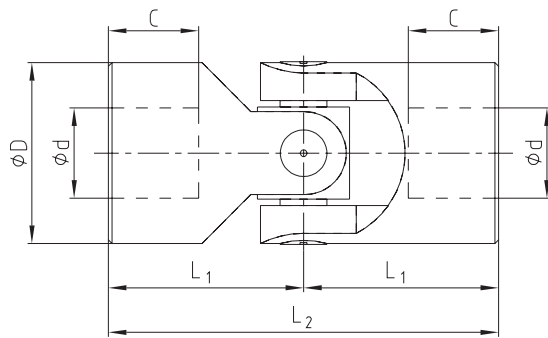

Precision double joint XD

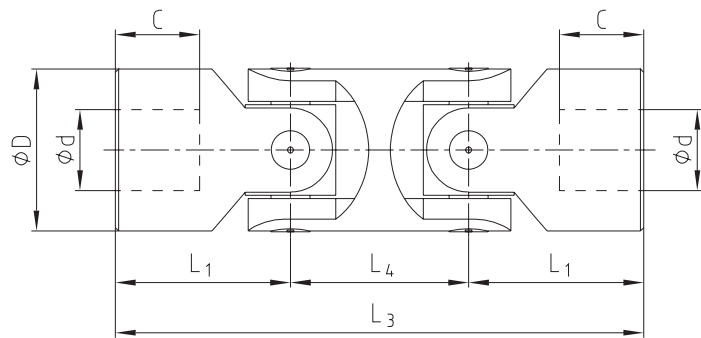

Finish bores:

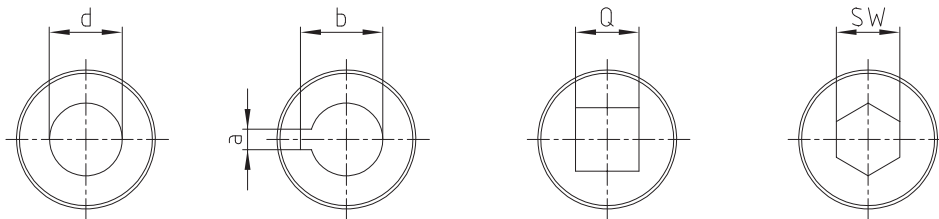

Type X and XD																
Types and size				Dimensions [mm]											Weight [kg]	
Size X	DIN designation X	Size XD	DIN designation XD	d (H7)	D	L ₂	L ₁	C	L ₄	L ₃	a (JS9)	b	Q (H10)	SW (H10)	X	XD
01 X	E6 x 16-G	01 XD	D6 x 16-G	6	16	34	17	8	22	56	2	7.0	6	6	0.05	0.08
02 X	E8 x 16-G	02 XD	D8 x 16-G	8	16	40	20	11	22	62	2	9.0	8	8	0.05	0.08
03 X	E10 x 22-G	03 XD	D10 x 22-G	10	22	48	24	12	26	74	3	11.4	10	10	0.10	0.15
04 X	E12 x 25-G	04 XD	D12 x 25-G	12	25	56	28	13	30	86	4	13.8	12	12	0.16	0.25
1 X	E16 x 32-G	1 XD	D16 x 32-G	16	32	68	34	16	37	105	5	18.3	16	16	0.30	0.45
3 X	E20 x 42-G	3 XD	D20 x 42-G	20	42	82	41	18	47	129	6	22.8	20	20	0.60	1.00
5 X	E25 x 50-G	5 XD	D25 x 50-G	25	50	108	54	26	55	163	8	28.3	25	25	1.20	2.00
6 X	E30 x 58-G	6 XD	D30 x 58-G	30	58	122	61	29	68	190	8	33.3	30	30	1.85	2.90

Ordering example:	04 X	Ø12	Ø12 keyway to DIN
	Size and type of joint	Finish bore (H7)	Finish bore (H7), feather keyway acc. to DIN 6885 sheet 1 (JS9)

KTR Precision joints type GR and HR

Plain and needle bearing with quick locking

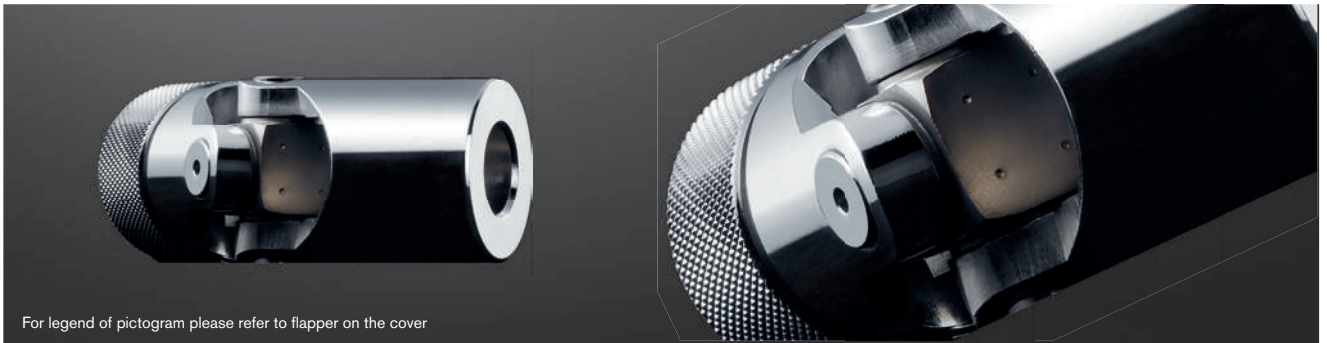

For legend of pictogram please refer to flapper on the cover

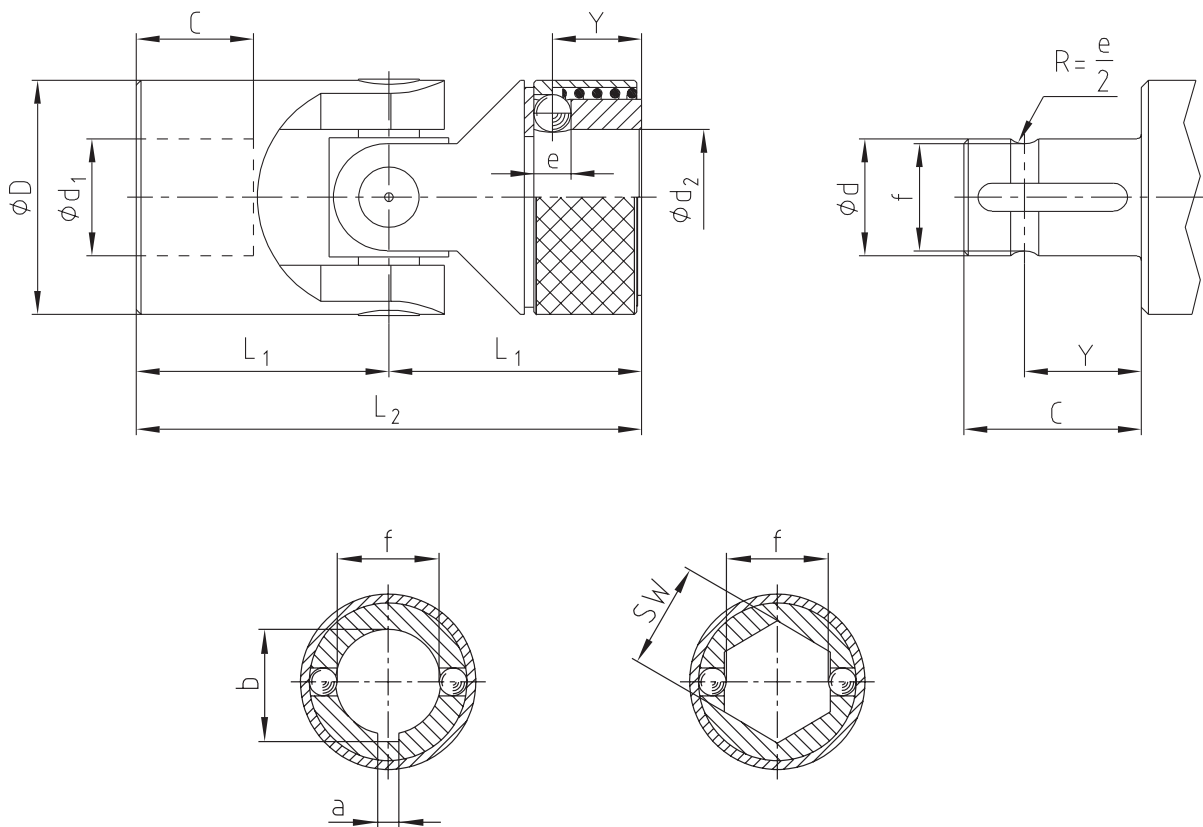

Type GR with plain bearing $n_{max.} = 1000$ rpm and type HR with needle bearing $n_{max.} = 4000$ rpm

Size		Dimensions [mm]											Weight [kg]
GR	HR	d_1, d_2 (H7)	D	L_2	L_1	C	Y	e	f	a (JS9)	b	SW (H10)	
02 GR	-	8	16	52	26	14	9.5	3.5	6.3	2	9.0	8	0.05
03 GR	03 HR	10	22	62	31	17	11.5	4.0	8.7	3	11.0	10	0.12
04 GR	04 HR	12	25	74	37	21	13.5	4.0	11.0	4	13.3	12	0.19
05 GR	05 HR	14	25	74	37	21	13.5	4.0	13.0	5	15.3	14	0.17
1 GR	1 HR	16	32	86	43	24	14.0	6.35	14.8	5	18.3	16	0.34
2 GR	2 HR	18	36	96	48	28	19.0	8.0	16.0	6	20.8	18	0.48
3 GR	3 HR	20	42	108	54	31	19.0	8.0	18.0	6	22.8	20	0.76
4 GR	4 HR	22	45	120	60	34	20.5	10.0	20.0	6	24.8	22	0.97
5 GR	5 HR	25	50	132	66	38	20.5	10.0	23.0	8	28.3	25	1.3
6 GR	6 HR	30	58	166	83	49	25.0	10.0	28.0	8	33.3	30	2.13

Ordering example:	03 HR	$d_1 = \varnothing 10$	$d_2 = \varnothing 10$ keyway to DIN
	Size and type of joint	Finish bore (H7)	Finish bore (H7), feather keyway acc. to DIN 6885 sheet 1 (JS9)

Protection bushings

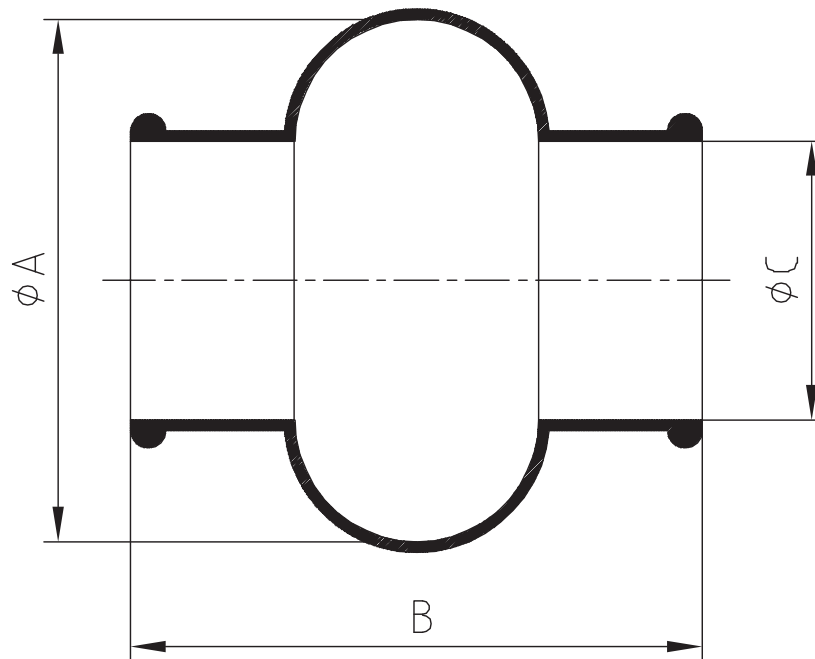

Protection bushings				
Size	Precision joints	A	B	C
M 01	01 G, 01 X	28	34	15
M 02	02 G, 02 X, 02 GR	32	40	16.5
M 03	03 G, 03 H, 03 GA, 03 HA, 03 X, 03 GR, 03 HR	40	45	20.5
M 04	04 G, 04 H, 04 GA, 04 HA, 04 X, 04 GR, 04 HR	48	50	24.5
M 05	05 G, 05 H, 05 GA, 05 HA, 05 GR, 05 HR	52	56	27.5
M 1	1 G, 1 H, 1 GA, 1 HA, 1 X, 1 GR, 1 HR	56	65	30.5
M 2	2 G, 2 H, 2 GA, 2 HA, 2 GR, 2 HR	66	72	35.5
M 3	3 G, 3 H, 3 GA, 3 HA, 3 X, 3 GR, 3 HR	75	82	40.0
M 4	4 G, 4 H, 4 GA, 4 HA, 4 GR, 4 HR	84	95	45.0
M 5	5 G, 5 H, 5 GA, 5 HA, 5 X, 5 GR, 5 HR	92	108	50.0
M 6	6 G, 6 G1, 6 H, 6 H1, 6 GA, 6 HA, 6 X, 6GR, 6 HR	100	122	56.0

CLAMPEX®

Clamping nuts

KTR Precision joints

Clamping sets



Torque measuring technology

Torque measuring shafts
Types and operating description 326

DATAFLEX®

Type 16/10, 16/30, 16/50	328
Type 32/100, 32/300, 32/500	330
Type 42/1000	332
Type 70/3000, 70/5000	334
Type 110/10000, 110/20000	336
Type 140/50000	337
Connection accessories	338

DATAFLEX® 16

DATAFLEX® 32

DATAFLEX® 42

DATAFLEX® 70

DATAFLEX® 110

DATAFLEX® 140



TORQUE MEASURING TECHNOLOGY TYPES AND OPERATING DESCRIPTION

Properties of torque measuring shafts

DATAFLEX® 16, 32, 42, 70, 110 - High precision with each revolution



With the new size of DATAFLEX® 110 KTR extend their range of precision measuring shafts for bigger torques. Along with the established sizes of DATAFLEX® 16 to DATAFLEX® 110 measuring ranges from 10 Nm to 20,000 Nm are covered.

With the new series the torque is measured using the approved technology of wire strain gauges DMS while processing contactlessly with a resolution of 24 bit. Thus, the inaccuracy of torque measuring is reduced to less than 0.1 % of the measuring range. By integrating a high-resolution speed sensor the new series combines four measurements in one: Measuring the torque, speed, rotation angle and rotation direction is part of the standard equipment.

DATAFLEX® 140 - Technology at top prices

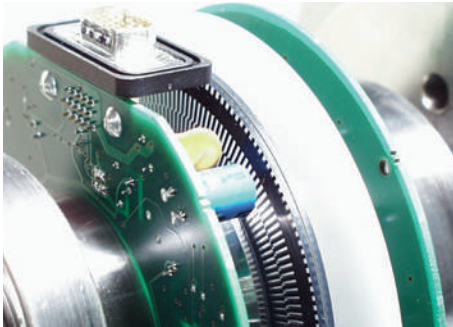

The DATAFLEX® torque measuring shafts size 140 measure the torque contactlessly and free from wear. Their secret is a measuring method sensing twisting of the torsion shaft by light quantity measurement. Here the light is directed through two disks the transparency of which changes proportionately to the torque. The overall electronics are installed in a stationary housing to make sure that no signals have to be transmitted by the rotating shaft and the torque is available completely with a high band width of 16 kHz. This allows to measure and analyze highly dynamic processes accurately.

The analog output values are available both as a voltage signal from 0 - 10 V and as a current signal from 4 - 20 mA. In addition a speed encoder is fitted as a standard providing a signal at a resolution of 60 pulses per revolution.

Couplings adjusted to every application



Matching with all series of DATAFLEX® we recommend to use the servo lamina coupling RADEX®-NC and the steel lamina coupling RADEX®-N. Together they form a compact solution which is easy to integrate while having a high stiffness. Basically it is also possible to use backlash-free, plug-in types of couplings such as ROTEX® GS or to fit an overload coupling.

TORQUE MEASURING TECHNOLOGY TYPES AND OPERATING DESCRIPTION

Product finder of torque measuring shafts

Product	DATAFLEX® 16	DATAFLEX® 32	DATAFLEX® 42	DATAFLEX® 70	DATAFLEX® 110	DATAFLEX® 140
Maintenance-free	●	●	●	●	●	●
For rotating applications	●	●	●	●	●	●
Torque range T_{KN} [Nm]	10, 30, 50	100, 300, 500	1000	3000, 5000	10000, 20000	50000
Measuring inaccuracy [% of final value]	0.1	0.1	0.1	0.1	0.1	1
Torque output	-10 ... 10 V	-10 ... 10 V	-10 ... 10 V	-10 ... 10 V	-10 ... 10 V	0 ... 10 V, 4 ... 20 mA
Speed output						
Square-wave signal [pulses/rev.]	2 x 360	2 x 720	2 x 720	2 x 450	2 x 720	1 x 60
DC - direct voltage signal [0 ... 10V]	●	●	●	●	●	●
Direction signal	●	●	●	●	●	–
Maximum speed [rpm]	10,000	7,500	6,500	4,000	3,000	2,000
Coupling recommended	RADEX®-NC 20, 25	RADEX®-N 42, 60	RADEX®-N 80	RADEX®-N 90, 115	as specified	as specified
Connection housing DF2	●	●	●	●	●	●

Connection housing DF2 - All Inclusive



The connection housing DF2 can easily be combined with all DATAFLEX® torque measuring shafts disposing of a retainer for top hat rail assembly as well as terminal screws for an easy connection of external devices.

The following features save the purchase of expensive measuring amplifiers and converters:

- The torque output can be filtered over 5 steps so that short torque peaks in the display can be reduced.
- The pulsed outputs of the speed signals can be configured both for 5V (TTL) and 24V (HTL) controls. This makes the outputs compatible with data logging boards and SPS controls.
- In parallel with the pulse signal an integrated frequency voltage converter supplies a DC voltage from 0 – 10 V proportionally to the speed, the scaling of which can be individually adapted. This makes an expensive counter superfluous so that the signal can either be processed as a voltage or displayed.
- A direction signal indicates the rotational direction of the drive (with DATAFLEX® 16, 32, 42, 70 and 110).

DATAFLEX® 16/10, 16/30, 16/50 TORQUE MEASURING SHAFTS

For torques from 10 to 50 Nm

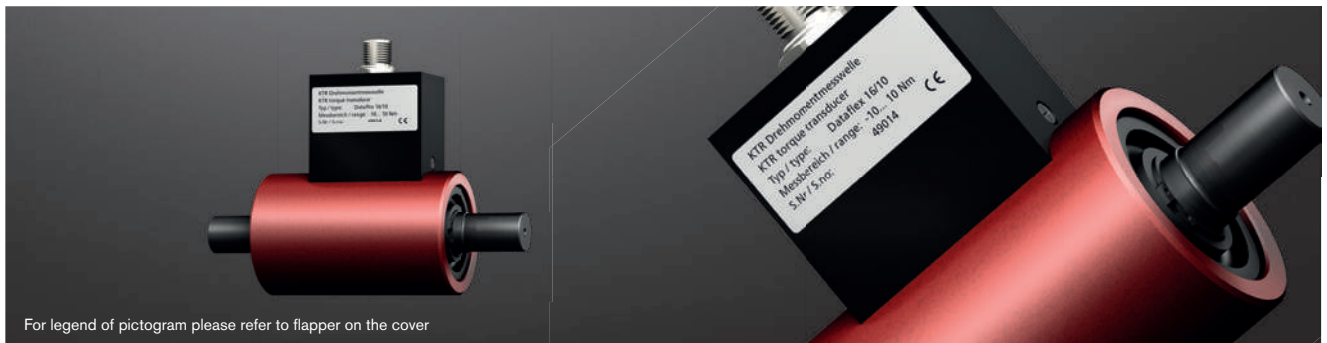

General properties

Type of DATAFLEX®	Rated torque T_{KN} [Nm]	Supply voltage [V]	Current consumption [mA]	Operating temperature range [°C]
16/10	-10 ... +10	24 ± 4	< 100	0 ... 55
16/30	-30 ... +30			
16/50	-50 ... +50			

Technical data of torque signal

Technical data of speed signal

Type of DATAFLEX®	Inaccuracy ^{1,2)} [%]	Output voltage [V]	Band width [kHz]	Influence of temperature ¹⁾ [%/10 °C]	Resolution [pulses/rev.]	Number of channels	Square-wave signal ³⁾ [V _{ss}]	Direct voltage signal ³⁾ [V]	Direction signal ³⁾ [V]
16/10	< 0.1	-10 ... 10	2	0.05	360	2, 90° offset	5/24	0 ... 10, scalable	5/24
16/30									
16/50									

Mechanical data of torque measuring shaft

Type of DATAFLEX®	Static load limit ¹⁾ $T_{K \max}$ [%]	Breaking load $T_{K \text{ break}}$ ¹⁾ [%]	Max. bending torque [Nm]	Max. radial force [N]	Max. axial force [kN]	Weight [kg]	Torsion spring stiffness C_T [Nm/rad]	Torsion angle with T_{KN} [°]	Mass moment of inertia [kgmm ²]	Max. speed [rpm]
16/10	150	300	1.07	12	1.1	0.7	910	0.63	22.6	10000
16/30			3.2	37	2.3		2840	0.61		
16/50			5.3	61	3.1		4100	0.7		

Mechanical data of combination DATAFLEX® 16 and RADEX®-NC

Type of DATAFLEX®	Coupling			Mechanical data of combination			
	RADEX®-NC size	Clamping screw M		Mass moment of inertia [kgmm ²]	Torsion spring stiffness C_T [Nm/rad]	Weight [kg]	Max. speed ⁴⁾ [rpm]
		M	T_A [Nm]				
16/10	20	M6	10	330.5	860	1.30	7500
16/30	25	M8	25	809	2600	1.75	
16/50				3600	1.75		

¹⁾ Referring to rated torque T_{KN}

²⁾ Error in linearity incl. hysteresis

³⁾ See page 332: with connection housing DF2

⁴⁾ Higher speed on request; with high speeds please use coupling hubs that are balanced

Ordering example:

DATAFLEX® 16/30	DF2	2 m, 5 m and 10 m	RADEX®-NC 25 EK Ø16/20-Ø16/30
Type of measuring shaft with measuring range	Connection housing (is required)	Connection cable	If accessories are requested: coupling type, finish bores d/d_1 - d/d_2

Components

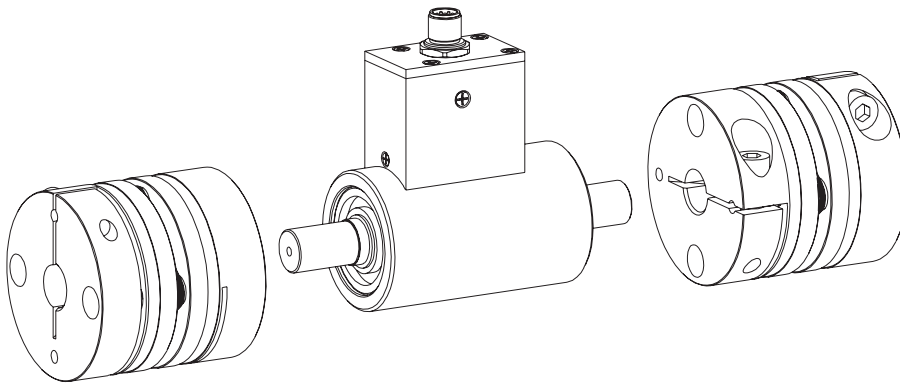

DATAFLEX® 16

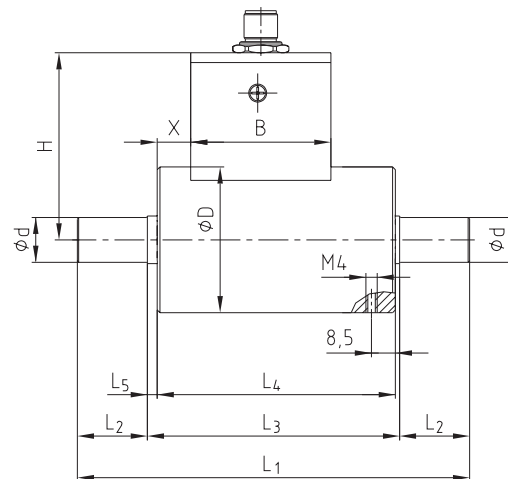

Combination of DATAFLEX® 16 with RADEX®-NC

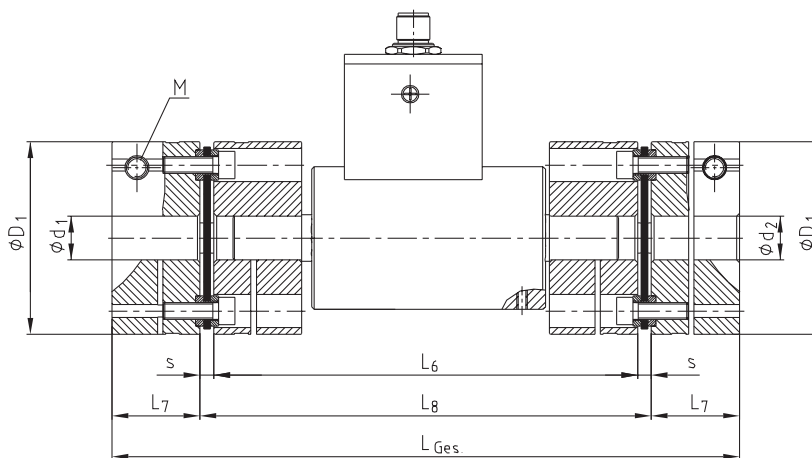

Dimensions [mm] of torque measuring shaft and coupling combination

Type of DATAFLEX®	d	D	L ₁	L ₂	L ₃	L ₄	L ₅	H	B	X	RADEX®-NC size	D ₁	d ₁ , d ₂ max.	s	L ₆	L ₇	L ₈	L _{total}
16/10											20	59	25	4	138	24	146	194
16/30	16	52	140	25	90	85	3.5	67	50	12	25	70	35	5	154	32	164	228
16/50																		

DATAFLEX® 32/100, 32/300, 32/500 TORQUE MEASURING SHAFTS

For torques from 100 to 500 Nm



For legend of pictogram please refer to flapper on the cover



General properties

Type of DATAFLEX®	Rated torque T_{KN} [Nm]	Supply voltage [V]	Current consumption [mA]	Operating temperature range [°C]
32/100	-100 ... +100	24 ± 4	< 100	0 ... 55
32/300	-300 ... +300			
32/500	-500 ... +500			

Technical data of torque signal

Technical data of speed signal

Type of DATAFLEX®	Inaccuracy ^{1,2)} [%]	Output voltage [V]	Band width [kHz]	Influence of temperature ¹⁾ [%/10 °C]	Resolution [pulses/rev.]	Number of channels	Square-wave signal ³⁾ [Vss]	Direct voltage signal ³⁾ [V]	Direction signal ³⁾ [V]
32/100	< 0.1	-10 ... 10	2	0.05	720	2, 90° offset	5/24	0 ... 10, scalable	5/24
32/300									
32/500									

Mechanical data of torque measuring shaft

Type of DATAFLEX®	Static load limit ¹⁾ $T_{K \max}$ [%]	Breaking load $T_{K \text{ break}}$ ¹⁾ [%]	Max. bending torque [Nm]	Max. radial force [N]	Max. axial force [kN]	Weight [kg]	Torsion spring stiffness C_T [Nm/rad]	Torsion angle with T_{KN} [°]	Mass moment of inertia [kgmm ²]	Max. speed [rpm]
32/100	150	300	11	110	5.0	1.9	18000	0.32	219	7500
32/300			32	320	10.4		46000	0.37	221	
32/500			53	530	14.6		60000	0.48	224	

Mechanical data of combination DATAFLEX® 32 and RADEX®-N

Type of DATAFLEX®	Coupling				Mechanical data of combination			
	RADEX®-N size	Setscrew			Mass moment of inertia [kgmm ²]	Torsion spring stiffness C_T [Nm/rad]	Weight [kg]	Max. speed ⁴⁾ [rpm]
		G	t	T_A [Nm]				
32/100	42	M8	20	10	5900	16000	6.95	7500
32/300	60				40000	11.65	6700	
32/500					49000	11.70		

¹⁾ Referring to rated torque T_{KN}

²⁾ Error in linearity incl. hysteresis

³⁾ See page 332: with connection housing DF2

⁴⁾ Higher speed on request

Ordering example:

DATAFLEX® 32/300	DF2	2 m, 5 m and 10 m	RADEX®-N 60 NN Ø32/50NnD Ø32/60NnD
Type of measuring shaft with measuring range	Connection housing (is required)	Connection cable	If accessories are requested: coupling type, finish bores d/d_1 - d/d_2

Components

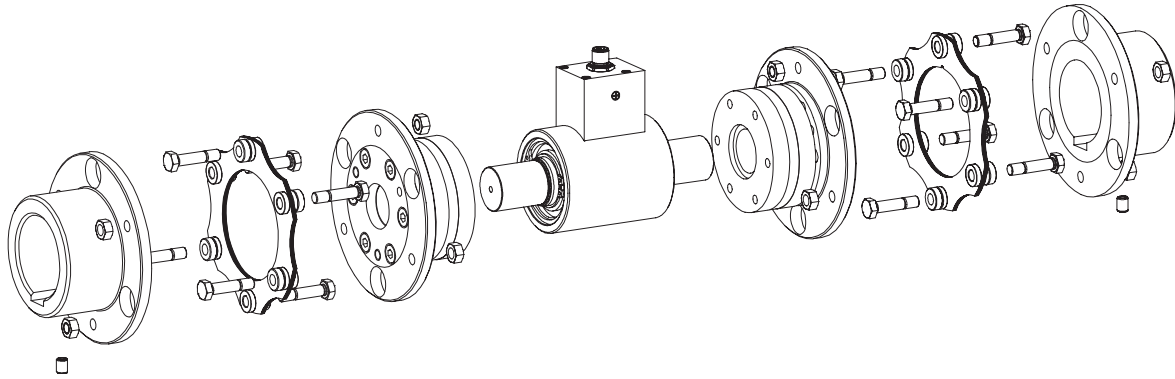

DATAFLEX® 32

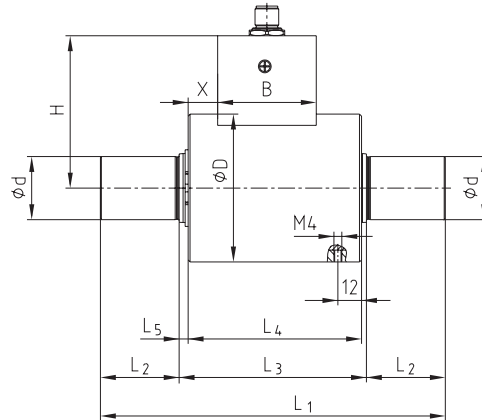

Combination of DATAFLEX® 32 with RADEX®-N

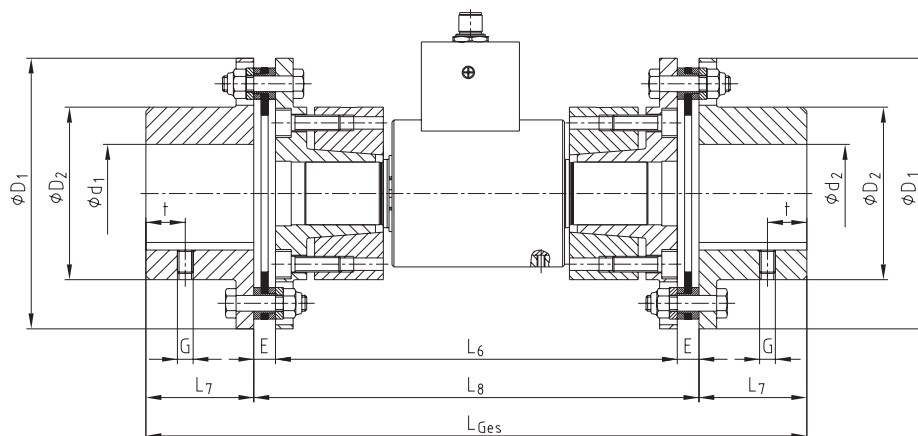

Dimensions [mm] of torque measuring shaft and coupling combination

Type of DATAFLEX®	d	D	L ₁	L ₂	L ₃	L ₄	L ₅	H	B	X	RADEX®-N size	D ₁	D ₂	d ₁ , d ₂ max.	E	L ₆	L ₇	L ₈	L _{total}
32/100	32	75	175	40	95	88	4.5	77.3	50	15	42	104	68	42	10	185	45	205	295
32/300											60	138	88	60	11	205	55	227	337
32/500																			

DATAFLEX® 42/1000 TORQUE MEASURING SHAFTS

For torques up to 1000 Nm



For legend of pictogram please refer to flapper on the cover



General properties				
Type of DATAFLEX®	Rated torque T_{KN} [Nm]	Supply voltage [V]	Current consumption [mA]	Operating temperature range [°C]
42/1000	-1000 ... +1000	24 ±4	< 100	0 ... 55

Technical data of torque signal					Technical data of speed signal				
Type of DATAFLEX®	Inaccuracy ^{1,2)} [%]	Output voltage [V]	Band width [kHz]	Influence of temperature ¹⁾ [%/10 °C]	Resolution [pulses/rev.]	Number of channels	Square-wave signal ³⁾ [V _{ss}]	Direct voltage signal ³⁾ [V]	Direction signal ³⁾ [V]
42/1000	<0.1	-10 ... 10	2	0.05	720	2, 90° offset	5/24	0 ... 10, scalable	5/24

Mechanical data of torque measuring shaft										
Type of DATAFLEX®	Static load limit ¹⁾ $T_{K \max}$ [%]	Breaking load $T_{K \text{ break}}$ ¹⁾ [%]	Max. bending torque [Nm]	Max. radial force [N]	Max. axial force [kN]	Weight [kg]	Torsion spring stiffness C_T [Nm/rad]	Torsion angle with T_{KN} [°]	Mass moment of inertia [kgmm ²]	Max. speed [rpm]
42/1000	150	300	107	780	24	3.43	132000	0.43	710	6500

Mechanical data of combination DATAFLEX® 42 and RADEX®-N									
Type of DATAFLEX®	Coupling				Mechanical data of combination				
	RADEX®-N size	Setscrew			Mass moment of inertia [kgmm ²]	Torsion spring stiffness C_T [Nm/rad]	Weight [kg]	Max. speed [rpm] ⁴⁾	
		G	t	T_A [Nm]					
42/1000	80	M10	20	17	61000	107000	23.1	5100	

¹⁾ Referring to rated torque T_{KN}

²⁾ Error in linearity incl. hysteresis

³⁾ See page 332: with connection housing DF2

⁴⁾ Higher speed on request

Ordering example:	DATAFLEX® 42/1000	DF2	2 m, 5 m and 10 m	RADEX®-N 80 NN Ø42/50NnD Ø42/60NnD
		Type of measuring shaft with measuring range	Connection housing (is required)	Connection cable

Components

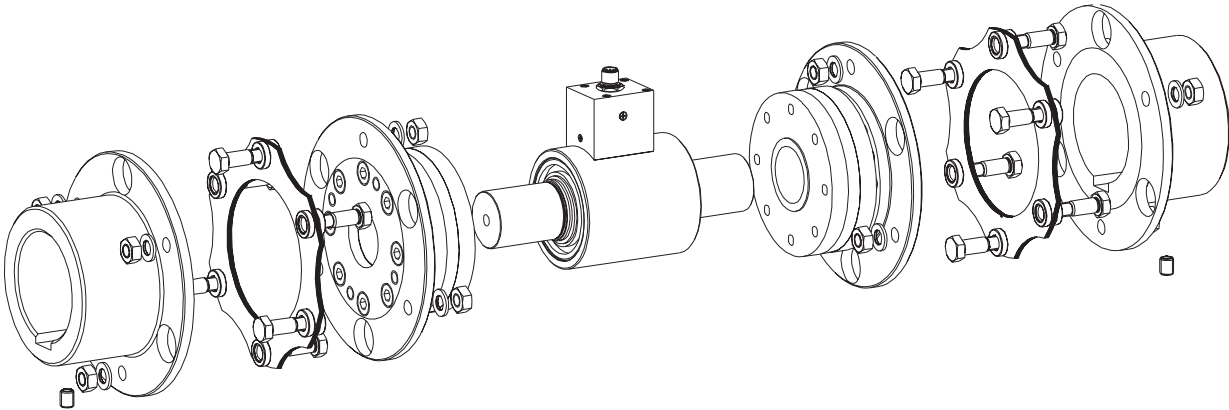

DATAFLEX® 42

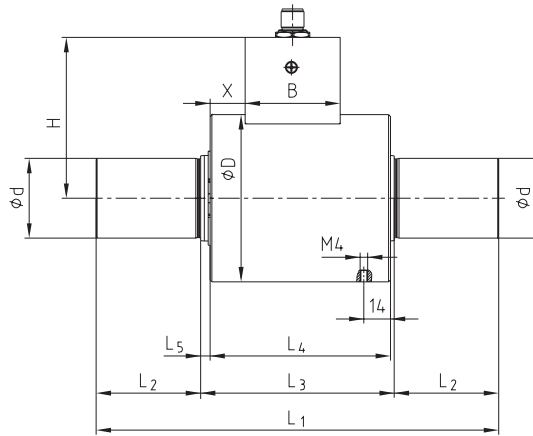

Combination of DATAFLEX® 42 with RADEX®-N

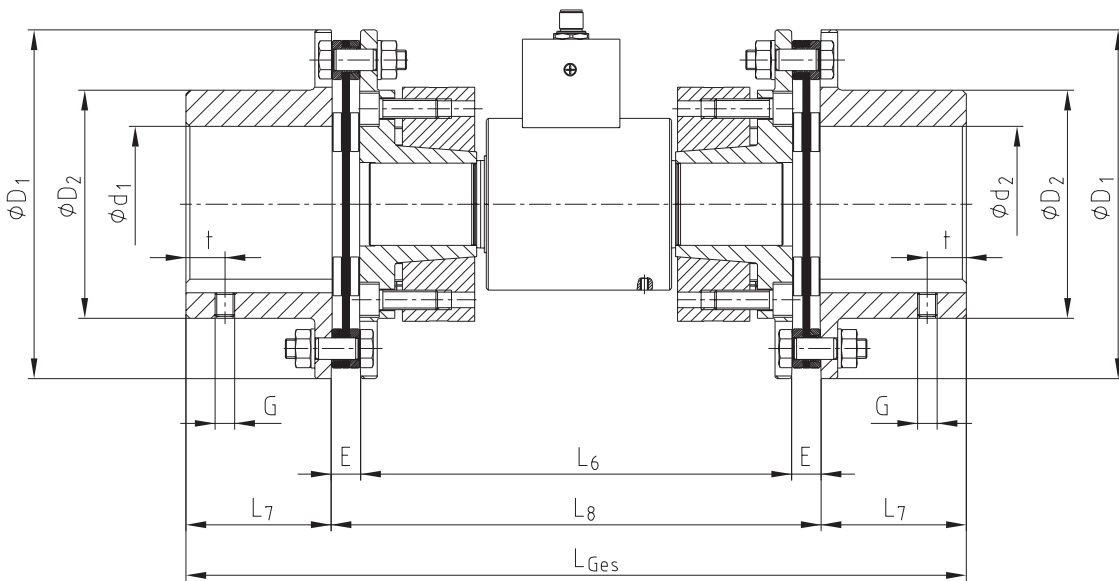

Dimensions [mm] of torque measuring shaft and coupling combination

Type of DATAFLEX®	d	D	L ₁	L ₂	L ₃	L ₄	L ₅	H	B	X	RADEX®-N size	D ₁	D ₂	d ₁ , d ₂ max.	E	L ₆	L ₇	L ₈	L _{total}
42/1000	42	88	212	55	102	95	5	84.7	50	18.5	80	179	117	80	14	222	75	250	400

DATAFLEX® 70/3000, 70/5000 TORQUE MEASURING SHAFTS

For torques from 3000 to 5000 Nm



For legend of pictogram please refer to flapper on the cover



General properties										
Type of DATAFLEX®	Rated torque T_{KN} [Nm]		Supply voltage [V]		Current consumption [mA]		Operating temperature range [°C]			
70/3000	-3000 ... +3000		24 ±4		<100		0 ... 55			
70/5000	-5000 ... +5000									
Technical data of torque signal					Technical data of speed signal					
Type of DATAFLEX®	Inaccuracy ¹⁾ [%]	Output voltage [V]	Band width [kHz]	Influence of temperature ¹⁾ [%/10 °C]	Resolution [pulses/rev.]	Number of channels	Square-wave signal ²⁾ [Vss]	Direct voltage signal ²⁾ [V]	Direction signal ²⁾ [V]	
70/3000	< 0.1	-10 ... 10	2	0.05	450	2, 90° offset	5/24	0 ... 10, scalable	5/24V	
70/5000										
Mechanical data of torque measuring shaft										
Type of DATAFLEX®	Static load limit ¹⁾ $T_{K \max}$ [%]	Breaking load $T_{K \text{ break}}$ ¹⁾ [%]	Max. bending torque [Nm]	Max. radial force [N]	Max. axial force [kN]	Weight [kg]	Torsion spring stiffness C_T [Nm/rad]	Torsion angle with T_{KN} [°]	Mass moment of inertia [kgmm ²]	Max. speed [rpm]
70/3000	150	300	320	1700	48	12.30	395000	0.44	7200	4000
70/5000			520	2800	66	12.45	500000	0.57	7300	
Mechanical data of combination DATAFLEX® 70 and RADEX®-N										
Type of DATAFLEX®	Coupling				Mechanical data of combination					
	RADEX®-N size	Setscrew			Mass moment of inertia [kgmm ²]	Torsion spring stiffness C_T [Nm/rad]	Weight [kg]	Max. speed [rpm] ⁴⁾		
		G	t	T_A [Nm]						
70/3000	90	M12	25	40	155200	283000	44.7	4000		
70/5000	115		30		470000	389000	77.6	3400		

¹⁾ Referring to rated torque T_{KN}

²⁾ See page 332: with connection housing DF2

³⁾ Higher speed on request

Ordering example:

DATAFLEX® 70/5000	DF2	2 m, 5 m and 10 m	RADEX®-N 115 NN Ø65/60Nd Ø65/70Nd
Type of measuring shaft with measuring range	Connection housing (is required)	Connection cable	If accessories are requested: coupling type, finish bores d/d_1 - d/d_2

Components

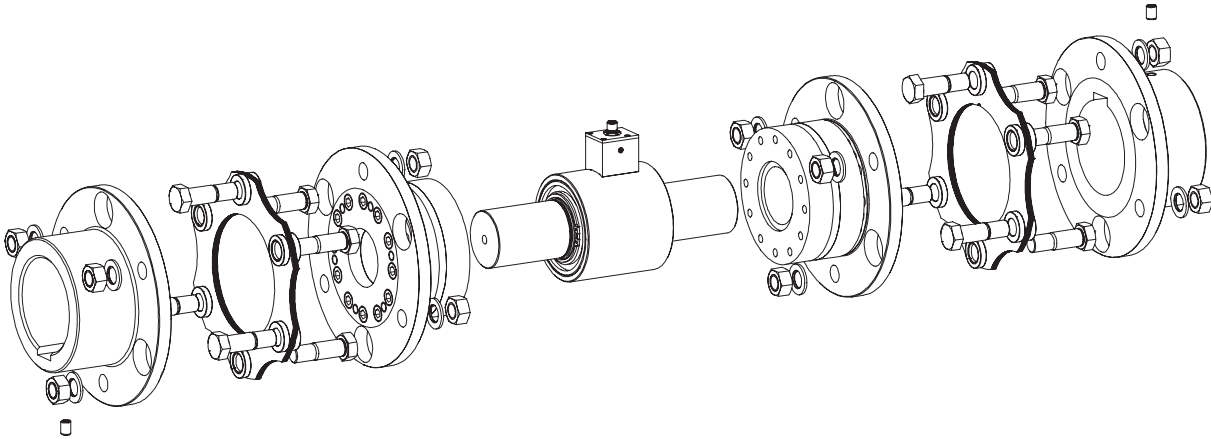

DATAFLEX® 70

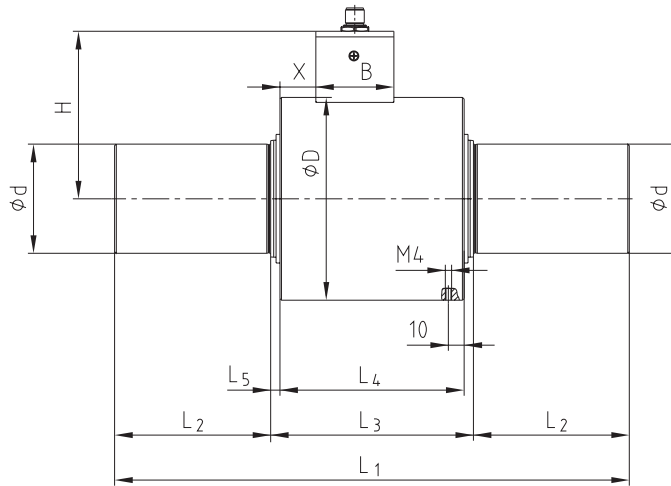

Combination of DATAFLEX® 70 with RADEX®-N

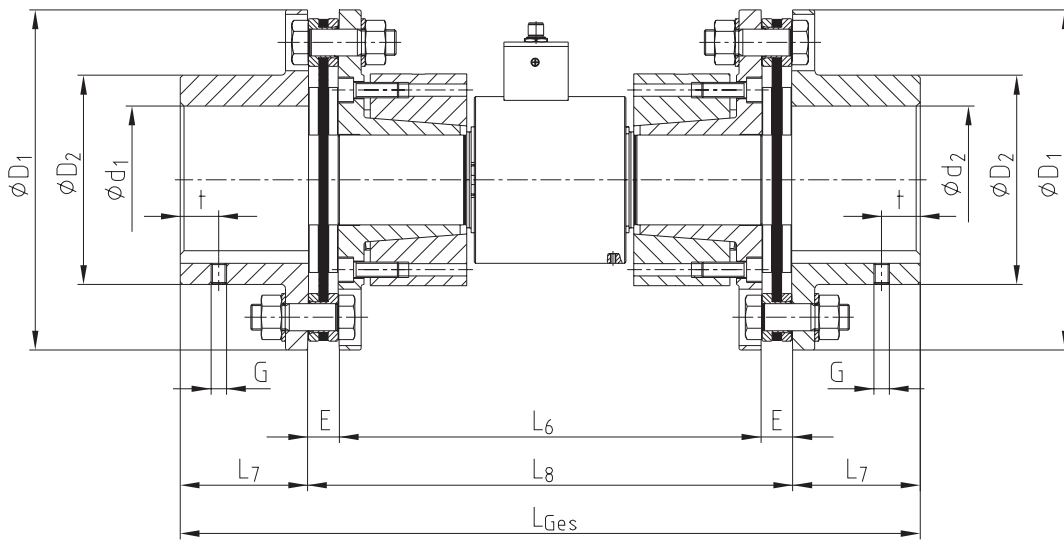

Dimensions [mm] of torque measuring shaft and coupling combination

Type of DATAFLEX®	d	D	L ₁	L ₂	L ₃	L ₄	L ₅	H	B	X	RADEX®-N size	D ₁	D ₂	d ₁ , d ₂ max.	E	L ₆	L ₇	L ₈	L _{total}
70/3000	70	130	330	100	130	118	6	107.35	50	23	90	210	132	90	15	330	80	360	520
70/5000	70	130	330	100	130	118	6	107.35	50	23	115	265	163	115	23	330	100	376	576

DATAFLEX® 110/10000, 110/20000 TORQUE MEASURING SHAFTS

For torques from 10000 to 20000 Nm



DATAFLEX® 110

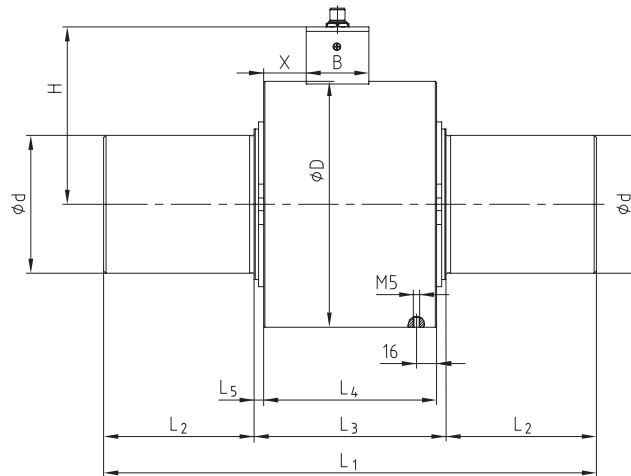

General properties

Type of DATAFLEX®	Rated torque T_{KN} [Nm]	Supply voltage [V]	Current consumption [mA]	Operating temperature range [°C]
110/10000	- 10000 ... + 10000	24 ± 4	<100	0 ... 55
110/20000	- 20000 ... + 20000			

Technical data of torque signal

Technical data of speed signal

Type of DATAFLEX®	Inaccuracy ¹⁾ [%]	Output voltage [V]	Band width [kHz]	Influence of temperature ¹⁾ [%/10 °C]	Resolution [pulses/rev.]	Number of channels	Square-wave signal ²⁾ [V _{SS}]	Direct voltage signal ²⁾ [V]	Direction signal ²⁾ [V]
110/10000	< 0.1	-10 ... +10	2	0.05	720	2, 90° offset	5/24	0 ... 10, scalable	5/24
110/20000									

Mechanical data of torque measuring shaft

Type of DATAFLEX®	Static load limit ¹⁾ $T_{K \max}$ [%]	Breaking load $T_{K \text{ break}}$ ¹⁾ [%]	Max. bending torque [Nm]	Max. radial force [N]	Max. axial force [kN]	Weight [kg]	Torsion spring stiffness C_T [Nm/rad]	Torsion angle with T_{KN} [°]	Mass moment of inertia [kgmm ²]	Max. speed [rpm]
110/10000	150	300	1033	4700	106	35.72	2270000	0.25	0.0562	3000
110/20000			2037	9300	166	36.20	3550000	0.32	0.0569	

Dimensions [mm] of torque measuring shaft

Type of DATAFLEX®	d	D	L ₁	L ₂	L ₃	L ₄	L ₅	H	B	X
110/10000	110	196	393	120	153	138	7.5	141.4	50	34
110/20000										

¹⁾ Referring to rated torque T_{KN}

²⁾ See page 332: with connection housing DF2

³⁾ Higher speed on request

Ordering example:

DATAFLEX® 110/10000	DF2	2 m, 5 m and 10 m
Type of measuring shaft with measuring range	Connection housing (is required)	Connection cable

DATAFLEX® 140/50000 TORQUE MEASURING SHAFT

For torques up to 50000 Nm

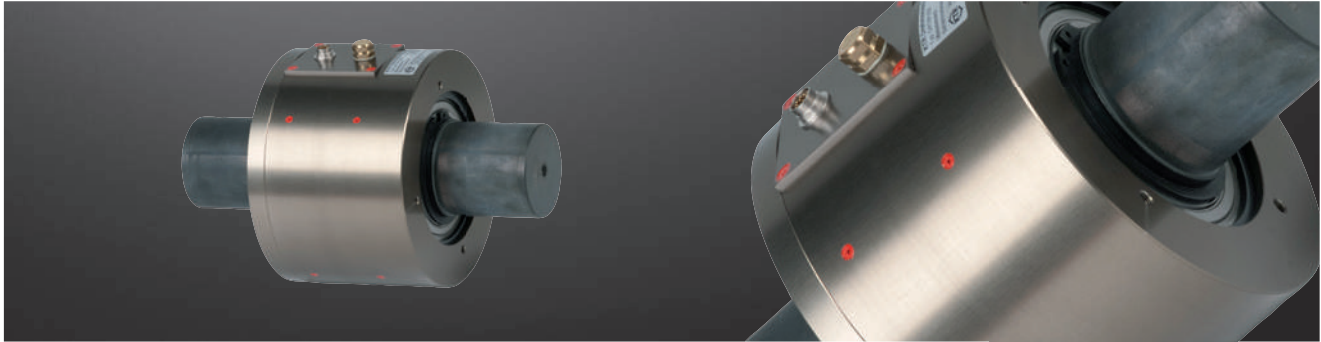

DATAFLEX® 140

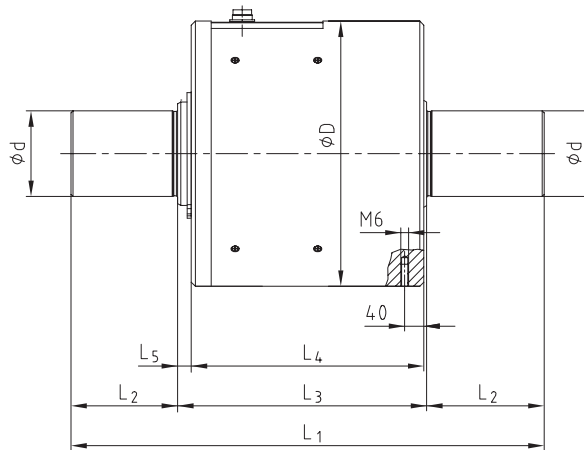

General properties

Type of DATAFLEX®	Rated torque T_{KN} [Nm]	Supply voltage [V]	Current consumption [mA]	Operating temperature range [°C]
140/50000	-50000 ... +50000	24 ±4	< 100	0 ... 55

Technical data of torque signal

Technical data of speed signal

Type of DATAFLEX®	Inaccuracy ¹⁾ [%]	Output voltage [V]	Output current [mA]	Band width [kHz]	Influence of temperature ¹⁾ [%/10 °C]	Resolution [pulses/rev.]	Number of channels	Square-wave signal ²⁾ [V _{ss}]	Direct voltage signal ²⁾ [V]	Direction signal ²⁾ [V]
140/50000	< ±0.5	0 ... 10	4 ... 20	16	0.5	60	1	5/24	0 ... 10, scalable	-

Mechanical data of torque measuring shaft

Type of DATAFLEX®	Static load limit ¹⁾ $T_{K \max}$ [%]	Breaking load TK break ¹⁾ [%]	Max. bending torque [Nm]	Max. radial force [N]	Max. axial force [kN]	Weight [kg]	Torsion spring stiffness C_T [Nm/rad]	Torsion angle with T_{KN} [°]	Mass moment of inertia [kgmm ²]	Max. speed [rpm]
140/50000	150	300	5500	16000	160	76.5	6750000	0.42	175000	2000

Dimensions [mm] of torque measuring shaft

Type of DATAFLEX®	d	D	L ₁	L ₂	L ₃	L ₄	L ₅
140/50000	140	280	486	140	206	191	13

¹⁾ Referring to rated torque T_{KN}

²⁾ See page 332: with connection housing DF2

Ordering example:

DATAFLEX® 140/50000	DF2	2 m, 5 m and 10 m
Type of measuring shaft with measuring range	Connection housing (is required)	Connection cable

DATAFLEX® CONNECTION ACCESSORIES TORQUE MEASURING SHAFTS

Connection housing DF2 and connection cable

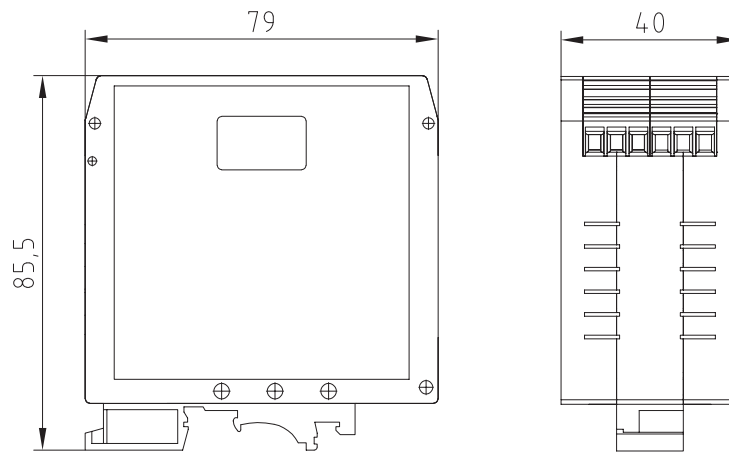
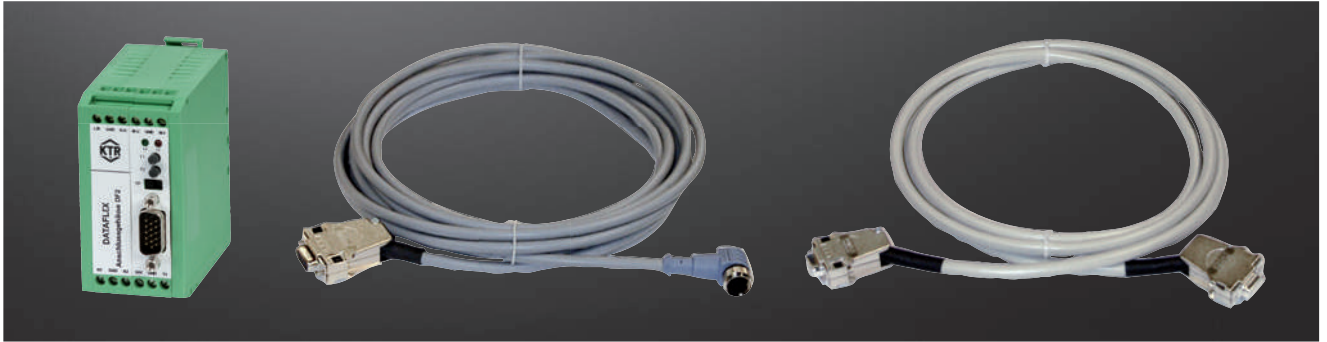

Connection cable and connection housing DF2							
Designation	Function	DATAFLEX® 16	DATAFLEX® 32	DATAFLEX® 42	DATAFLEX® 70	DATAFLEX® 110	DATAFLEX® 140
Connections DF2							
Input operating voltage							
24V	Supply voltage +	24 V DC ± 4V / 100mA max.					
GND	Supply voltage -						
Torque output							
M-U	Voltage output +	-10 V ... 10V					0 V ... 10 V
GND		Mass of torque output					
M-I	Current output	-	-	-	-	-	4 mA ... 20 mA
Speed output pulse signal							
N1	Pulsed output speed track 1	HTL, TTL (24V, 5V, 360 pulses/rev.)	HTL, TTL (24V, 5V, 720 pulses/rev.)	HTL, TTL (24V, 5V, 720 pulses/rev.)	HTL, TTL (24V, 5V, 450 pulses/rev.)	HTL, TTL (24V, 5V, 720 pulses/rev.)	HTL, TTL (24V, 5V, 1 x 60 pulses/rev.)
GND		Mass of pulsed output					
N2	Pulsed output speed track 2	HTL, TTL (24V, 5V, 360 pulses/rev.)	HTL, TTL (24V, 5V, 720 pulses/rev.)	HTL, TTL (24V, 5V, 720 pulses/rev.)	HTL, TTL (24V, 5V, 450 pulses/rev.)	HTL, TTL (24V, 5V, 720 pulses/rev.)	-
Speed of direct voltage output							
R/L	Direction signal speed	HTL, TTL (24V, 5V, CW = 1)					-
GND		Mass of direct voltage output speed					
N-U	Voltage output speed	0 V ... 10 V (scalable)					
Other connections / operating devices							
T1	Sensor T1 - connection	External sensor connection T1					
L1, L2	Signal LEDs	Condition monitoring					
T1, T2	Sensor T1, T2	Sensor for programming					
TP	Switch low pass	Filter for torque signal to be set in four stages					
Connection cable							
Lengths of connection cable		2, 5, 10 m, other lengths on request					

Summary of literature

No matter if a perfect drive, a brake that takes effect, space-saving cooling or accurate hydraulics is required, if on land, by sea or at an airy height - KTR's product portfolio is just as manifold as its applications. The following catalogues and leaflets provide an overview. Available at www.ktr.com

Product catalogues

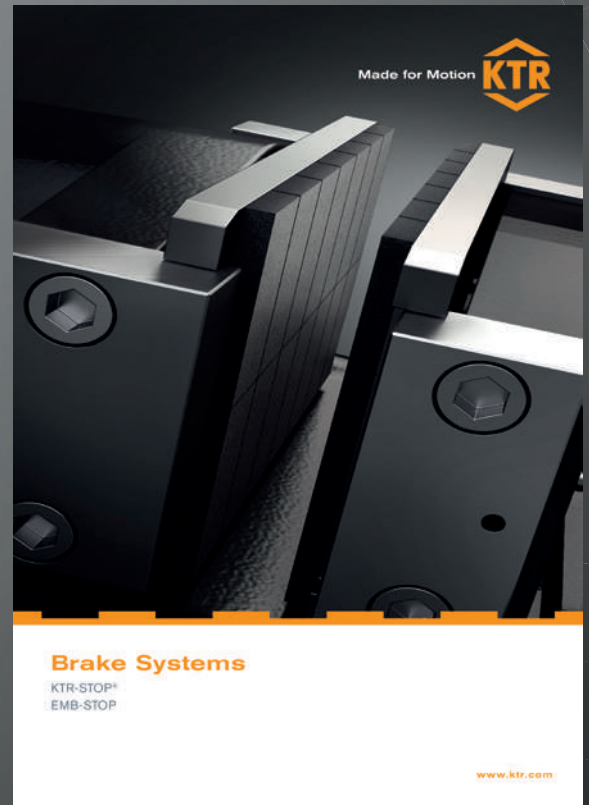

ATEX leaflet

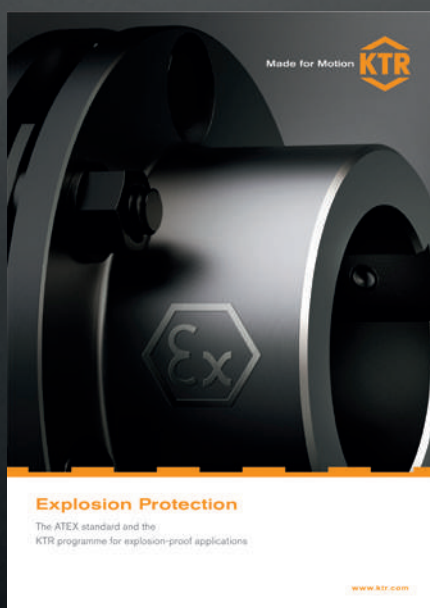

Company leaflet





Made for Motion **KTR**

Hydraulic Components

Bellhousings
Damping Elements
Tanks

www.ktr.com



Made for Motion **KTR**

Cooling systems

For mobile machines and stationary hydraulics
Customised solutions or standard design

www.ktr.com

KTR Germany:

Headquarters:

KTR Systems GmbH
Carl-Zeiss-Straße 25
D-48432 Rheine
Phone: +49 5971 798-0
Fax: +49 5971 798-698 or 798-450
E-mail: mail@ktr.com
Internet: www.ktr.com

KTR Brake Systems GmbH

Competence Center for Brake Systems
Zur Brinke 14
D-33758 Schloß Holte-Stukenbrock
Phone: +49 5207 99161-0
Mobile: +49 175 2650033
Fax: +49 5207 99161-11

Leiter Vertrieb Bremsen Wind

Jörn Edzards, Dipl.-Ing. (FH)
Zur Brinke 14
D-33758 Schloß Holte-Stukenbrock
Phone: +49 5207 99161-0
Mobile: +49 175 2650033
E-mail: j.edzards@ktr.com

Leiter Vertrieb Bremsen Industrie

Thomas Wienkotte, Dipl.-Ing. (FH)
Peter-Schumacher-Straße 102
D-50171 Kerpen
Phone: +49 2237 971796
Mobile: +49 172 5859448
E-mail: t.wienkotte@ktr.com

Außendienst Norddeutschland für Hydraulik-Komponenten

Gunnar Ehlers
Finkenstieg 4b
21629 Neu Wulmstorf
Mobile: +49 174 3301536
E-mail: g.ehlers@ktr.com

Außendienst Bayern, Baden-Württemberg und Österreich für Hydraulik-Komponenten

Klaus-Peter Sprödhuber
Hussengutstr. 55
95445 Bayreuth
Phone: +49 921 16388991
Mobile: +49 172 1096496
E-mail: k.sproedhuber@ktr.com

Schleswig-Holstein, Nord-Niedersachsen, Hamburg, Bremen

Martin Lau, Maschinenbautechniker
KTR, Ingenieurbüro Hamburg
Geschwister-Scholl-Allee 44
25524 Itzehoe
Phone: +49 4821 4050812
Mobile: +49 172 5310014
E-mail: m.lau@ktr.com

NRW: Reg.-Bez.: Düsseldorf

Günter Enk, Dipl.-Ing.
KTR Ingenieurbüro Bocholt
Stormstraße 17
46397 Bocholt
Phone: +49 2871 227488
Mobile: +49 172 5355704
E-mail: g.enk@ktr.com

Pia Wiesmann, Maschinenbautechnikerin

KTR Ingenieurbüro Bocholt
Stormstraße 17
46397 Bocholt
Phone: +49 2871 227488
Mobile: +49 172 5730670
E-mail: p.wiesmann@ktr.com

Emsland, Mitte- und Süd-Niedersachsen, Ostwestfalen

Rainer Lüttmann
KTR Systems GmbH
Carl-Zeiss-Straße 25
48432 Rheine
Phone: +49 5971 798-340
Mobile: +49 172 5322164
E-mail: r.luettmann@ktr.com

Ruhrgebiet, Siegerland, Hessen-Nord

René Pottmann, Maschinenbautechniker
KTR Ingenieurbüro Dortmund
Lindemannstraße 9
44137 Dortmund
Phone: +49 231 91259060
Mobile: +49 162 2186045
E-mail: r.pottmann@ktr.com

Hessen, Rheinland-Pfalz, Saarland

Martin Dietrich, Ingenieur
KTR Ingenieurbüro Frankfurt
Schorbachstr. 9
35510 Butzbach
Phone: +49 6033 9248494
Mobile: +49 172 5329968
E-mail: m.dietrich@ktr.com

Berlin, Mecklenburg-Vorpommern

Südost, Sachsen-Anhalt, Brandenburg
Thüringen Nord, Sachsen
Norman Schlag, Tech. BW (IHK)
KTR Ingenieurbüro Leipzig
Hauptstraße 101
04416 Markkleeberg
Phone: +49 341 35416467
Mobile: +49 173 4716266
E-mail: n.schlag@ktr.com

Baden-Württemberg Nord

Eberhard Maier, Dipl.-Ing. (FH)
Hortensienweg 1
70374 Stuttgart, Sommerrain
Phone: +49 7116 5842957
Mobile: +49 172 5355056
E-mail: e.maier@ktr.com

Baden-Württemberg Süd

Jochen Glöckler, Maschinenbautechniker
KTR Ingenieurbüro Balingen
Hölzlestraße 44
72336 Balingen
Phone: +49 7433 91381
Mobile: +49 172 5310049
E-mail: j.gloeckler@ktr.com

Bayern-Nord, Thüringen Süd

Alexander Ennulat, Dipl.-Ing.
KTR Ingenieurbüro Römerstein
Grabenstetterstraße 28
72587 Römerstein
Phone: +49 7382 9369226
Mobile: +49 162 4160354
E-mail: a.ennulat@ktr.com

Bayern-Süd, Baden-Württemberg Ost

Peter Benkard, Dipl.-Ing. (FH)
KTR Ingenieurbüro Adelsried
Am Mittelfeld 13
86477 Adelsried
Phone: +49 8293 960504
Mobile: +49 172 5313059
E-mail: p.benkard@ktr.com

For all representatives and sales partners please refer to www.ktr.com.

KTR worldwide:

Algeria

KTR Alger
Algeria Business Center -
Pins Maritimes
DZ-16130 Alger Mohammadia
Phone: +213 661 92 24 00
E-mail: ktr-dz@ktr.com

Brazil

KTR do Brasil Ltda.
Rua Jandaia do Sul 471 -
Bairro Emiliano Perneta
Pinhais - PR - Cep: 83324-040
Phone: +55 41 36 69 57 13
Fax: +55 41 36 69 57 13
E-mail: ktr-br@ktr.com

Chile

KTR Systems Chile SpA
Calle Bucarest 17
Oficina 33 Providencia
Santiago de Chile
Phone: +56 23 22 46 674
Mobile: +56 9 44 75 57 02
E-mail: ktr-cl@ktr.com

China

KTR Power Transmission Technology
(Shanghai) Co. Ltd.
Building 1005, ZOBON Business Park
999 Wangqiao Road
Pudong
Shanghai 201201
Phone: +86 21 58 38 18 00
Fax: +86 21 58 38 19 00
E-mail: ktr-cn@ktr.com

Czech Republic

KTR CR, spol. s r.o.
Brněnská 559
569 43 Jevíčko
Czech Republic
Phone: +420 461 325 014
E-mail: ktr-cz@ktr.com

Finland

KTR Finland OY
Tiistiniityntie 4
SF-02230 Espoo
PL 23
SF-02231 Espoo
Phone: +358 2 07 41 46 10
Fax: +358 2 07 41 46 19
E-mail: ktr-fi@ktr.com

France

KTR France S.A.R.L.
5 CHEMIN DE LA BROCARDIERE
F-69570 DARDILLY
Phone: +33 478 64 54 66
Fax: +33 478 64 54 31
E-mail: ktr-fr@ktr.com

India

KTR Couplings (India) Pvt. Ltd.,
T-36 / 37 / 38, MIDC Bhosari
Pune 411026
Phone: +91 20 27 12 73 22
Fax: +91 20 27 12 73 23
E-mail: ktr-in@ktr.com

Italy

KTR Systems GmbH
Sede Secondaria Italia
Via Giovanni Brodolini, 8
I - 40133 Bologna (BO)
Phone: +39 051 613 32 32
Fax: +39 02 700 37 570
E-mail: ktr-it@ktr.com

Japan

KTR Japan Co., Ltd.
Toei Bldg.2F, 6-1-8 Motomachi-dori
Chuo-ku, Kobe
650-0022 Japan
Phone: +81 7 89 54 65 70
Fax: +81 7 85 74 03 10
E-mail: ktr-jp@ktr.com

KTR Japan - Tokyo Office
1-11-6, Higashi-Ueno, Taito-Ku,
Tokyo 110-0015 Japan
(Takeno-building, 5F)
Japan
Phone: +81 3 58 18 32 07
Fax: +81 3 58 18 32 08

Korea

KTR Korea Ltd.
101, 978-10, Topyung-Dong
Guri-City, Gyeonggi-Do
471-060 Korea
Phone: +82 3 15 69 45 10
Fax: +82 3 15 69 45 25
E-mail: ktr-kr@ktr.com

Netherlands

KTR Benelux B. V.
Postbus 87
NL-7550 AB Hengelo (O)
Oosterveldsingel 3
NL-7558 PJ Hengelo (O)
Phone: +31 74 2553680
Fax: +31 74 2553689
E-mail: ktr-nl@ktr.com

Norway

KTR Systems Norge AS
Fjellbovegen 13
N-2016 Frogner
Phone: +47 64 83 54 90
Fax: +47 64 83 54 95
E-mail: ktr-no@ktr.com

Poland

KTR Polska Sp. z o.o.
ul. Czerwone Maki 65
PL-30-392 Kraków
Phone: +48 12 267 28 83
Fax: +48 12 267 07 66
E-mail: ktr-pl@ktr.com

KTR Steel Construction Sp. z o.o.

ul. Kolejowa 1
46-040 Ozimek
Phone: +48 77 402 68 50
Fax: +48 77 465 11 36
E-mail: ks.ozimek@ks.com.pl

Russia

KTR RUS LLC
6 Verhni Pereulok 12
Litera A, Office 229
194292 St. Petersburg
Phone: +7 812 383 51 20
Fax: +7 812 383 51 25
E-mail: ktr-ru@ktr.com
Internet: www.ktr.ru

South Africa

KTR Couplings SA (Pty) Ltd.
28 Spartan Road, Kempton Park,
GautengSpartan Ext. 21
Phone: +27 11 281 3801
Fax: +27 11 281 3812
E-mail: ktr-za@ktr.com

Spain

KTR Systems GmbH
Estartetxe, nº 5-Oficina 218
E-48940 Leioa (Vizcaya)
Phone: +34 9 44 80 39 09
Fax: +34 9 44 31 68 07
E-mail: ktr-es@ktr.com

Sweden

KTR Sverige AB
Box 742
S-191 27 Sollentuna
Phone: +46 86 25 02 90
Fax: +46 86 25 02 99
E-mail: info.se@ktr.com

Switzerland

KTR Systems Schweiz AG
Bahnstr. 60
CH-8105 Regensdorf
Phone: +41 4 33 11 15 55
Fax: +41 4 33 11 15 56
E-mail: ktr-ch@ktr.com

Taiwan

KTR Taiwan Ltd.
No.: 30-1, 36 Rd
Taichung Industry Zone
Taichung City
407 Taiwan (R. O. C.)
Phone: +886 4 23 59 32 78
Fax: +886 4 23 59 75 78
E-mail: ktr-tw@ktr.com

Turkey

KTR Turkey
Güç Aktarma Sistemleri San. ve Tic. Ltd.
Sti.
Kayışdağı Cad. No: 117/2
34758 Atasehir -Istanbul
Phone: +90 216 574 37 80
Fax: +90 216 574 34 45
E-mail: ktr-tr@ktr.com

United Kingdom

KTR U.K. Ltd.
Robert House
Unit 7, Acorn Business Park
Woodseats Close
Sheffield
United Kingdom, S8 0TB
Phone: +44 11 42 58 77 57
Fax: +44 11 42 58 77 40
E-mail: ktr-uk@ktr.com

USA

KTR Corporation
122 Anchor Road
Michigan City, Indiana 46360
Phone: +1 2 19 8 72 91 00
Fax: +1 2 19 8 72 91 50
E-mail: ktr-us@ktr.com





Headquarters
KTR Systems GmbH

Carl-Zeiss-Straße 25

D-48432 Rheine

Phone: +49 5971 798-0

Fax: +49 5971 798-698 or 798-450

E-mail: mail@ktr.com

Internet: www.ktr.com

Made for Motion



Certificates and Approvals

Being one of the first companies in the field of drive technology, KTR was certified in accordance with DIN EN ISO 9001 already in 1993, including the plants in Poland, China, India and USA.

Currently KTR products have been approved by numerous societies for standardization and classification being of international significance. Individual approvals by other societies can be implemented on request without fail.



Legend of pictograms



Torsionally rigid



Light-weight



Protected against corrosion



Torsionally flexible

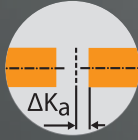

Axial compensation



Electrically insulating



Highly flexible

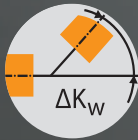

Angular compensation



Maximum speed



Damping vibrations

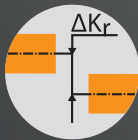

Radial compensation



No eddy current losses



Axial plug-in



Shiftable at standstill



Torque limiter slipping



Consider shaft distance



Relatively short shaft distance



Double-cardanic



Torque limiter with synchronous ratcheting



Relatively short shaft distance



Radial disassembly Ease of service



Torque limiter with idle rotation type

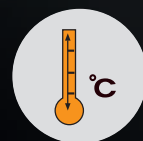

Maximum operating temperature



Standard drop-out center lengths available



Hardened surface



High speeds



Available in accordance with API



Accuracy X %



Backlash-free



Complying with ATEX For details refer to our ATEX leaflet



Consider axial displacement



Shear type, separating, slipping



Maintenance-free



Additional features compared to standard version