

HIWIN®

Motion Control & Systems



Linear Guideways

Linear Guidance Systems

Linear guideways & accessories

A linear guideway permits linear movement with the aid of rolling elements. By using balls or rollers between the rail and block, a linear guideway can attain an extremely precise linear movement. Compared with a standard sliding guide, the friction coefficient here is just one fiftieth. The good efficiency and zero play mean that the linear guideway can be used in various ways.

Linear guideways

Contents

Contents

1	Product overview	6
2	General information	8
2.1	Properties and advantages	8
2.2	Selection principles	9
2.3	Load ratings	10
2.4	Lifetime calculation	11
2.5	Operating load	13
2.6	Friction and lubrication	15
2.7	Mounting position	16
2.8	Assembly	17
2.9	Sealing systems	22
2.10	SynchMotion™ technology	24
2.11	Heat-resistant linear guideways	25
2.12	HIWIN coatings for linear guideways	26
3	Linear guideways	29
3.1	HG and QH series	29
3.2	EG and QE series	47
3.3	CG series	62
3.4	WE and QW series	78
3.5	MG series	90
3.6	RG and QR series	103
3.7	PG series	120
4	Accessories	128
4.1	Lubrication adapters	128
4.2	HIWIN grease guns and lubricants	132

Linear guideways

Product overview

1. Product overview

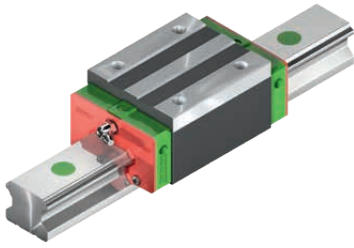

Linear guideway, series HG and QH

[Page 29](#)

- 4-row recirculation ball bearing guide
- 45° contact angle
- High loading capacity in all mounting positions
- High rigidity
- Block with SynchMotion™ technology (QH series)

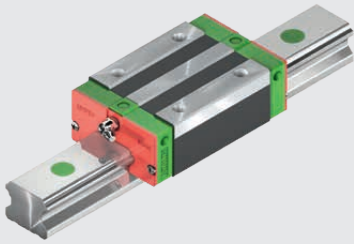

Linear guideway, series EG and QE

[Page 47](#)

- 4-row recirculation ball bearing guide
- 45° contact angle
- High loading capacity in all mounting positions
- Low installation height
- Block with SynchMotion™ technology (QE series)

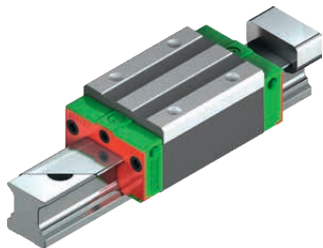

Linear guideway, series CG

[Page 62](#)

- 4-row recirculation ball bearing guide
- O-arrangement with 45° contact angle
- High torque loading capacity, especially rolling moment capacity
- Optional: rail with cover strip

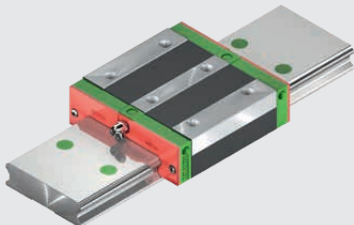

Linear guideway, series WE and QW

[Page 78](#)

- 4-row recirculating ball bearing guide
- 45° contact angle
- High torque loading capacity
- Low installation height
- Block with SynchMotion™ technology (QW series)

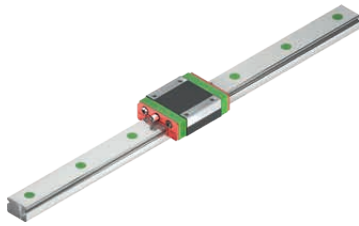

Linear guideway, series MG

[Page 90](#)

- 2-row recirculating ball bearing guide
- 45° contact angle
- Compact construction
- Narrow and wide designs

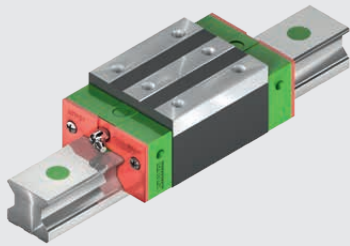

Linear guideway, series RG and QR

[Page 103](#)

- 4-row recirculation ball bearing guide
- 45° contact angle
- Roller guide
- Very high loading capacity
- Very high rigidity
- Block with SynchMotion™ technology (QR series)

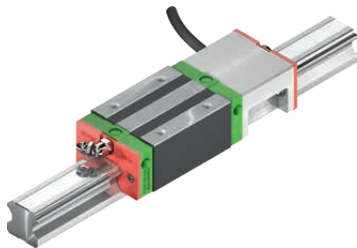

Linear guideway, series PG

[Page 120](#)

- HG, QH, CG series with integrated distance measuring system
- Zero contact distance measurement
- Simple attachment and assembly
- Signal output in real time

Accessories

[Page 128](#)

- Grease nipple
- Lubrication adapter
- Push-in fittings

Linear guideways

General information

2. General information

2.1 Properties and advantages

1. High positioning accuracy

A carriage mounted with a linear guideway only has to overcome rolling friction. The difference between the static and dynamic rolling friction is very small so the break-away force is only slightly greater than the motion force. Stick-slip effects are not experienced.

2. Long lifetime and highly precise movement

With a sliding guide, the different thicknesses of lubrication film may result in accuracy errors. The sliding friction and the fact that lubrication is often insufficient cause a lot of wear and therefore decreasing accuracy. Contrasted with this, the linear guideway has very low rolling friction, coupled with extremely low wear. Guidance accuracy remains virtually constant over the entire lifetime.

3. High speed and low driving force

The low friction coefficients mean that only low driving forces are needed. The required power also remains low when reversing.

4. Same high load capacity in all directions

Thanks to the enforced guidance inherent in its design, a linear guideway can absorb forces in a vertical and horizontal direction.

5. Simple installation and interchangeability

Assembling a linear guideway is a simple process. A high level of accuracy is achieved with a milled or ground mounting surface if the assembly instructions are followed. Standard sliding guides require considerably more effort to assemble as the sliding surfaces have to be scraped. Individual components cannot be interchanged without scraping. Linear guideways can however be interchanged with very little effort.

6. Simple lubrication

Insufficient lubrication on sliding guides destroys the sliding surfaces. Lubricant must be used at a large number of points on the sliding surfaces. The linear guideway only requires minimal lubrication which is provided by a simple supply line to the block. HIWIN can also supply blocks with an integrated oil lubrication unit and interchangeable oil tank for long-term lubrication.

7. Corrosion protection

To achieve optimum corrosion protection, blocks and rails can be supplied with different coatings. The individual procedures selected depend on the application. Data relating to the ambient conditions and corrosive substances is needed for an optimum choice of coating. The miniature linear guideway MG is produced in stainless steel.

2.2 Selection principles

Establish the selection conditions

- Machine base
- Max. installation space
- Desired accuracy
- Rigidity required
- Type of loading
- Travel distance
- Speed of travel, acceleration
- Frequency of use
- Lifetime
- Ambient conditions

Select the series

- HG and CG series – Grinding, milling and drilling machines, lathes, machining centres, woodworking
- EG series – Automation technology, high-speed transport, semiconductor equipment, precision measuring equipment
- WE series – Single axes with high torque loads M_x
- MG series – Miniature technology, semiconductor equipment, medical technology
- RG series – Machining centres, injection moulding machines, machines and systems with high rigidity

Select the accuracy class

- Classes C, H, P, SP, UP depending on the accuracy required

Define the size and number of blocks

- Depending on empirical values
- Depending on type of loading
- If a ballscrew is used, the nominal size of the linear guideways and the ballscrew should be roughly the same, e.g. 32 ballscrew and 35 rail

Calculate the maximum load of the blocks

- Calculate the maximum load using the sample calculations (see Section 2.5). Ensure that the static structural safety of the selected linear guideway is higher than the corresponding value in the table on static structural safety.

Determine the preload

- The preload depends on the rigidity requirements and the accuracy of the mounting surface.

Determine the rigidity

- Use the rigidity table to calculate the deformation (δ) the rigidity increases with preload and as the guide increases in size.

Calculate the lifetime

- Establish the lifetime needed taking account of the speed and frequency of travel; base work on sample calculations (see Section 2.4).

Select the type of lubrication

- Grease via grease nipple
- Oil via connection line

Selection complete

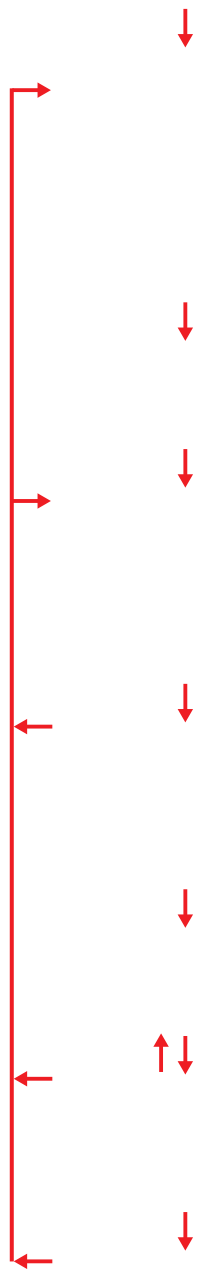

Linear guideways

General information

2.3 Load ratings

2.3.1 Static load rating C_0

If a linear guideway is subject to disproportionately high loads or impact during movement or when stationary, local permanent deformation occurs between the block and balls. Once this permanent deformation exceeds a particular level, it impacts on how easily the guide moves. By definition, the static load rating corresponds to a static load which causes a permanent deformation of $0.0001 \times$ ball diameter at the point of

contact subject to the most loading. The values are stated in the tables for each linear guideway. These tables can be used to select a suitable linear guideway. The maximum static load to which a linear guideway is subjected must not exceed the static load rating.

2.3.2 Permissible static moment M_0

The permissible static moment is the moment that corresponds to the greatest possible loading of moving parts by the static load rating in a defined direction and magnitude. The permissible static moment is defined in three directions (MX, MY and MZ) for linear movement systems.

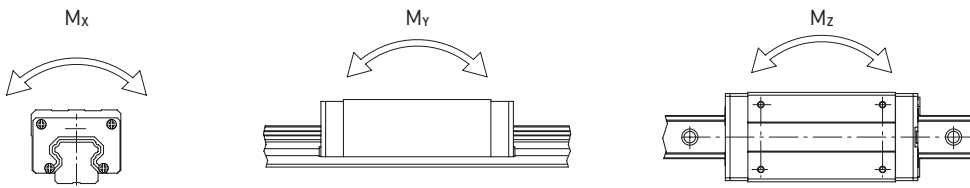

2.3.3 Static structural safety

Static structural safety, which depends on the ambient and operating conditions, must be taken into account for rail systems at rest or moving slowly. A higher level of structural safety is especially important for guides subject to impact loads, see [Table 2.1](#). The static structural safety can be calculated using [F 2.1](#).

F 2.1

$$f_{SL} = \frac{C_0}{P} ; f_{SM} = \frac{M_0}{M}$$

- f_{SL} Static structural safety
- f_{SM} Static safety factor for torque loading
- C_0 Static load rating [N]
- M_0 Permissible static moment [Nm]
- P Equivalent static working load [N]
- M Equivalent static moment [Nm]

Please note: The load-bearing capacity of the linear guideway is often limited not by its load-bearing strength, but the screw connection. We therefore recommend checking the maximum permitted load-bearing capacity of the screw connection in accordance with VDI 2230.

Table 2.1 Static structural safety	
Loading	f_{SL}, f_{SM} [min.]
Normal loading	1.25 – 3.00
With impact and vibration	3.00 – 5.00

2.3.4 Dynamic load rating C_{dyn}

The dynamic load rating is the defined loading (in direction and magnitude) at which a linear guideway achieves a nominal lifetime of $50 \text{ km}^{1)}$ travel distance (HG, QH, EG, QE, CG, WE, QW, MG) or $100 \text{ km}^{1)}$ (RG, QR). The dynamic load rating is stated for each guide in the dimension charts. This can be used to calculate the lifetime of one particular guide.

¹⁾ The dynamic load rating of linear guideways is stated for a lifetime of 50 or 100 km travel distance depending on the manufacturer. The following factors can be used to convert the dynamic load rating.

$$C_{dyn} 50 \text{ km} = 1.26 \times C_{dyn} 100 \text{ km (series HG, QH, EG, QE, CG, WE, QW, MG)}$$

$$C_{dyn} 50 \text{ km} = 1.23 \times C_{dyn} 100 \text{ km (series RG, QR)}$$

2.4 Lifetime calculation

2.4.1 Definition of lifetime

Continual and repeat loading of the tracks and balls on a linear guideway causes signs of fatigue on the track surface. Ultimately this results in what is known as pitting. The lifetime of a linear guideway is defined as the total travel distance covered until pitting starts to form on the surface of the track or balls.

2.4.2 Nominal lifetime (L)

The lifetime may vary significantly even if the linear guideways are produced in the same way and used under the same movement conditions. The nominal lifetime should therefore be viewed as a rough estimate of the lifetime of a linear guideway. The nominal lifetime corresponds to the total travel distance which 90 % of a group of identical linear guideways reach under the same conditions without failure.

2.4.2.1 Nominal lifetime calculation

The actual loading affects the nominal lifetime of a linear guideway. The nominal lifetime can be calculated with Formulas F 2.2 and F 2.3 using the selected dynamic load rating and equivalent dynamic loading.

Formulas for calculating nominal lifetime (L)

Series HG, QH, EG, QE, CG, WE, QW, MG:

F 2.2

$$L = \left(\frac{C_{dyn}}{P} \right)^3 \times 50 \text{ km}$$

L Nominal lifetime [km]
 C_{dyn} Dynamic load rating [N]
 P Equivalent dynamic loading [N]

Series RG, QR:

F 2.3

$$L = \left(\frac{C_{dyn}}{P} \right)^{10/3} \times 100 \text{ km}$$

2.4.2.2 Factors affecting nominal lifetime

The type of loading, hardness of the track and temperature of the guide have a considerable impact on the nominal lifetime. Formulas F 2.4 and F 2.5 show the relationship between these factors.

Hardness factor (f_h)

The tracks of the linear guideways have a hardness of 58 HRC. A hardness factor of 1.0 applies. If the hardness differs from this, the hardness factor shown on the right should be used. If the stated hardness is not reached, the permissible loading is reduced. If this happens, the dynamic and static load ratings must be multiplied by the hardness factor.

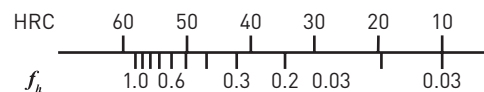

Temperature factor (f_t)

Standard rails can be used in an ambient temperature range of -10 to 80 °C. At ambient temperatures up to 150 °C, linear guideways with a metallic end cap must be used (identified in the type code by the addition "/SE"). Intermittent ambient temperatures of up to 180 °C are possible. However, we do recommend contacting our technical support team to be sure. If the temperature of a linear guideway exceeds 100 °C, the permissible load and lifetime are reduced. The dynamic and static load ratings must therefore be multiplied by the temperature factor.

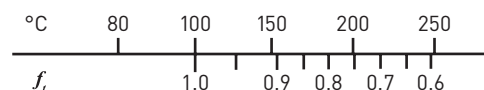

Linear guideways

General information

Load factor (f_w)

The equivalent dynamic load is multiplied by the load factor according to Table 2.2.

This takes into account the external effects on the rail's service life that are not entered directly in the calculations (e.g. vibrations, impacts, and high speed). For short-stroke applications (stroke $< 2 \times$ block length), the load factor determined must be doubled.

Type of loading	Speed of travel	f_w
No impact and vibration	up to 15 m/min	1.0 – 1.2
Normal load	15 m/min to 60 m/min	1.2 – 1.5
Little impact	60 m/min to 120 m/min	1.5 – 2.0
With impact and vibration	greater than 120 m/min	2.0 – 3.5

Formula for calculating nominal lifetime (taking factors into account)

Series HG, QH, EG, QE, CG, WE, QW, MG:

F 2.4

$$L = \left(\frac{f_h \times f_t \times C_{dyn}}{f_w \times P} \right)^3 \times 50 \text{ km}$$

L Nominal lifetime [km]
 f_h Hardness factor
 C_{dyn} Dynamic load rating [N]
 f_t Temperature factor
 P Equivalent dynamic loading [N]
 f_w Load factor

Series RG, QR:

F 2.5

$$L = \left(\frac{f_h \times f_t \times C_{dyn}}{f_w \times P} \right)^{10/3} \times 100 \text{ km}$$

2.4.3 Lifetime calculation (L_h)

The speed of travel and frequency of movement are used to calculate the lifetime in hours from the nominal lifetime.

Formula for calculating lifetime (L_h)

Series HG, QH, EG, QE, CG, WE, QW, MG:

F 2.6

$$L_h = \frac{L}{v \times 60} = \frac{\left(\frac{C_{dyn}}{P} \right)^3 \times 50,000}{v \times 60}$$

L_h Lifetime [h]
 L Nominal lifetime [m]
 v Speed [m/min]
 C_{dyn}/P Ratio between load rating and load

Series RG, QR:

F 2.7

$$L_h = \frac{L}{v \times 60} = \frac{\left(\frac{C_{dyn}}{P} \right)^{10/3} \times 100,000}{v \times 60}$$

2.5 Operating load

2.5.1 Operating load

When calculating the loads acting on a linear guideway, various factors must be taken into account, e.g. the focal point of the load, the motion force's point of entry and the mass inertia at the start and end of movement. To obtain a correct value, each parameter must be taken into account.

Load on a block

Table 2.3 Load on a block (examples of calculating load on a block)		
Typical examples	Distribution of load	Load on a block
		$P_1 = \frac{W}{4} + \frac{F}{4} + \frac{F \times a}{2c} + \frac{F \times b}{2d}$ $P_2 = \frac{W}{4} + \frac{F}{4} + \frac{F \times a}{2c} - \frac{F \times b}{2d}$ $P_3 = \frac{W}{4} + \frac{F}{4} - \frac{F \times a}{2c} + \frac{F \times b}{2d}$ $P_4 = \frac{W}{4} + \frac{F}{4} - \frac{F \times a}{2c} - \frac{F \times b}{2d}$
		$P_1 = P_3 = \frac{F \times l}{2d}$ $P_2 = P_4 = \frac{W}{4} + \frac{F \times l}{2d}$
		$P_1 = P_2 = P_3 = P_4 = -\frac{W \times h}{2d} + \frac{F \times l}{2d}$
		$P_1 = P_2 = -\frac{W \times h}{2c} - \frac{F \times l}{2c}$ $P_3 = P_4 = \frac{W \times h}{2c} + \frac{F \times l}{2c}$ $P_{t1} = P_{t3} = \frac{W}{4} + \frac{F}{4} + \frac{F \times k}{2d}$ $P_{t2} = P_{t4} = \frac{W}{4} + \frac{F}{4} - \frac{F \times k}{2d}$

$P_1 \dots P_4$ Load on the individual block
 W Weight of load
 F Motion force; other force arising
 l Distance from external force to carriage

c Rail spacing
 d Block spacing
 a, b, k Distance from external force to geometric center
 h Distance from center of gravity to driver

Linear guideways

General information

Load and mass inertia

Table 2.4 Load and mass inertia (examples of calculating load and mass inertia)	
	Load on one block
	<ul style="list-style-type: none"> ○ Constant velocity $P_1 \dots P_4 = \frac{W}{4}$ ○ Acceleration $P_1 = P_3 = \frac{W}{4} + \frac{1}{2} \times \frac{W}{g} \times \frac{v_c}{t_1} \times \frac{l}{d}$ $P_2 = P_4 = \frac{W}{4} - \frac{1}{2} \times \frac{W}{g} \times \frac{v_c}{t_1} \times \frac{l}{d}$ ○ Deceleration $P_1 = P_3 = \frac{W}{4} - \frac{1}{2} \times \frac{W}{g} \times \frac{v_c}{t_3} \times \frac{l}{d}$ $P_2 = P_4 = \frac{W}{4} + \frac{1}{2} \times \frac{W}{g} \times \frac{v_c}{t_3} \times \frac{l}{d}$

$P_1 \dots P_4$ Load on the individual block

W Weight of load

F Motion force

F_A Reaction force

g Gravitational acceleration [m/s^2]

v_c Velocity [m/s]

t_1 Acceleration time [s]

t_2 Constant speed time [s]

t_3 Deceleration time [s]

c Rail spacing [m]

d Block spacing [m]

l Distance from center of gravity to carriage [m]

2.5.2 Calculation of equivalent load during changing loads

If loading of a linear guideway fluctuates greatly, an equivalent load must be used in the lifetime calculation. The equivalent load is defined as the load which causes the same wear on the bearings as the changing loads. It can be calculated using [Table 2.5](#).

Table 2.5 Examples of calculating equivalent load (P_m)		
Gradual change	Steady change	Sinusoidal change
$P_m = \sqrt[3]{\frac{1}{L} (P_1^3 \times L_1 + P_2^3 \times L_2 + \dots + P_n^3 \times L_n)}$	$P_m = \frac{1}{3} (P_{\min} + 2 \times P_{\max})$	$P_m = 0.65 \times P_{\max}$

P_m Equivalent load

P_n Changing load

P_{\min} Minimum load

P_{\max} Maximum load

L Total travel distance

L_n Travel distance under load P_n

2.6 Friction and lubrication

2.6.1 Frictional resistance

Using rolling elements in the linear guideway mainly reduces friction on the roll friction of the rolling elements. This makes the friction coefficient of linear guideways very low, up to one fiftieth of that of traditional sliding guides. Generally, the friction coefficient is around 0.004 depending on the series. If the loading is only 10 % or less

of the dynamic load rating, most of the frictional resistance is caused by the wiper and grease and friction between the rolling elements. If the operating load is more than 10 % of the dynamic load rating, the load provides the majority of the frictional resistance.

F 2.8 $F = \mu \times W + S$

F	Frictional force [N]
S	Frictional resistance [N]
μ	Friction coefficient
W	Load [N]

2.6.2 Lubrication

Like any other roller bearing, linear guideways need a sufficient supply of lubricant. In principle, both oil and grease can be used for lubrication. The lubricant is a design element and should be taken into account when designing a machine.

Lubricants reduce wear, protect against contamination, reduce corrosion and their properties extend the service life. Dirt may build up on unprotected rails. This dirt must be removed on a regular basis.

HIWIN provides greases for various requirements:

- HIWIN G01: heavy-duty applications
- HIWIN G02: clean room and vacuum applications
- HIWIN G03: high-speed clean room and vacuum applications
- HIWIN G04: high-speed applications
- HIWIN G05: standard applications

You will find information about the HIWIN lubricants in the accessories chapter on [Page 132](#). You will also find details about the HIWIN lubricants and lubrication of the linear guideways in the Assembly Instructions “**Linear Guideways**” available from www.hiwin.de.

2.6.3 Oil lubrication unit E2

The oil lubrication unit E2 consists of a lubricating unit between the deflection system and the end seal, and an interchangeable oil tank. The block does not need to be disassembled in order to interchange the oil tank. Lubrication passes from the oil tank via the connector to the lubricating unit which then lubricates the track of the rail. Due to the specific design of the oil tank, the block can be assembled in any position

without influencing the lubrication effect. The oil lubrication unit E2 can be used at an ambient temperature of -10 °C to $+60\text{ °C}$. The replacement intervals depend greatly on the loads and the environmental conditions. Environmental influences such as high loads, vibrations and dirt shorten the replacement intervals.

The oil lubrication unit E2 is available for the HG, EG and RG series. You will find the corresponding dimensions, lubricant volumes and intervals in the chapters for the corresponding series. Series HG: [Page 42](#), series EG: [Page 58](#), series RG: [Page 114](#).

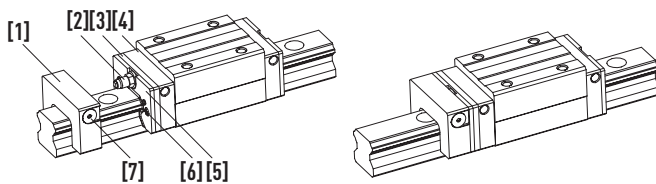

- [1] Oil tank
- [2] Connector
- [3] Lubrication unit
- [4] Deflection system
- [5] End seal
- [6] Screw
- [7] Seal plug

Applications

- Machine tools
- Production machines, injection moulding machines, paper industry, textile machines, foodstuffs industry, woodworking machines
- Electronics industry, semiconductor industry, robot technology, cross tables, measurement and test machines
- Other areas, medical equipment, automation, industrial handling

Linear guideways

General information

2.7 Mounting position

2.7.1 Examples of typical mounting positions

A linear guideway can absorb loads from above/below and right/left. The mounting position depends on the requirements of the machine and the loading direction. The precision of the rail is defined by the straightness and evenness of the installation surfaces, since the rail is attached to these while the screws are being tightened.

Profile rails that are not attached to an installation surface may have larger tolerances in terms of straightness. Below you will find typical mounting situations: Details of the assembly tolerances can be found in the chapters for the individual series.

A profile bar on a reference edge:

The reference edge is identified by arrows on the top of the rail. For very short rails, identification is on the front side of the rail.

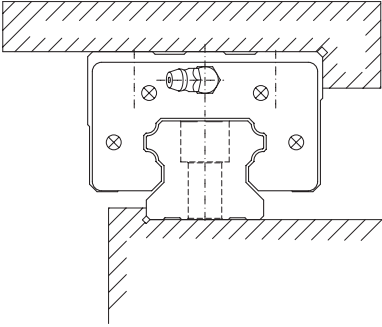

Two rails with mobile block:

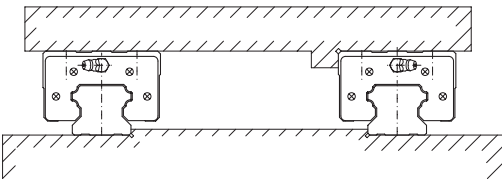

Two rails with permanently installed block:

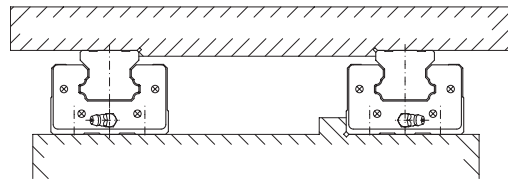

Two external blocks:

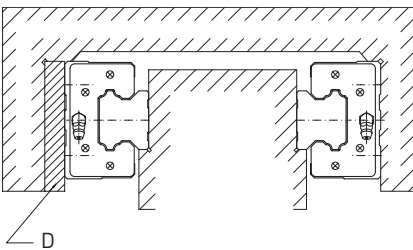

Two internal blocks:

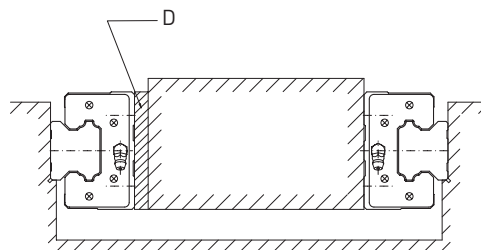

Setup with permanently installed surface:

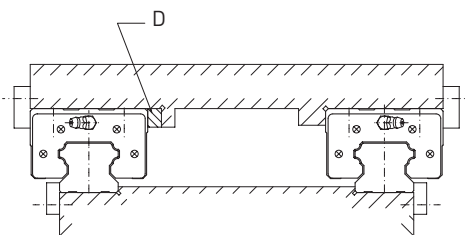

HGW_C block with different mounting directions:

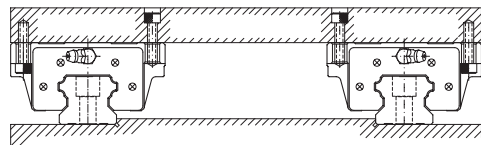

D Spacer

2.8 Assembly

Depending on the accuracy required and the linear guideway's impact and vibration loading, the following three types of assembly are recommended.

2.8.1 Assembly of rails with reference edge and clamp

If the machine is subject to severe vibration, impact or lateral force, guides and blocks may move. To avoid this problem and achieve a high level of rigidity and guidance accuracy, we would recommend assembling the linear guideway with reference edges and clamps on both sides.

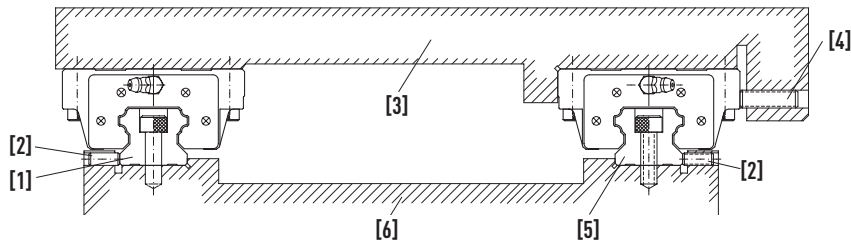

- [1] Following side
- [2] Guide clamping screw
- [3] Carriage
- [4] Block clamping screw
- [5] Reference side
- [6] Machine bed

2.8.1.1 Types of attachment

The following four types of attachment are recommended.

Attachment with a clamping plate:

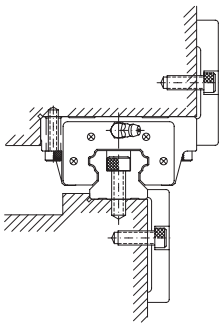

Attachment with clamping screws:

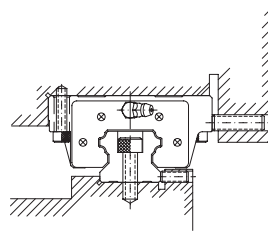

Attachment with clamping strips:

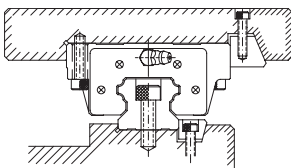

Attachment with needle rollers:

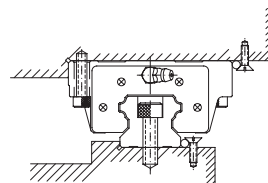

Linear guideways

General information

2.8.1.2 Assembly of the rails

1) Before beginning, remove all dirt from the surface of the machine

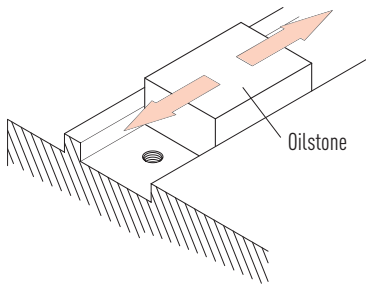

2) Place the rail carefully on the bed and align it with the reference edge

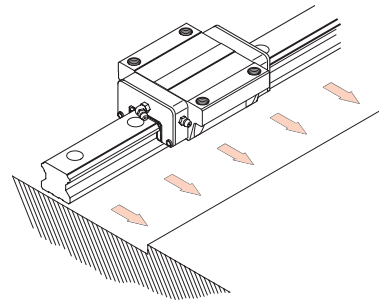

3) When aligning the rail on the bed, ensure that the thread engages with the screws used

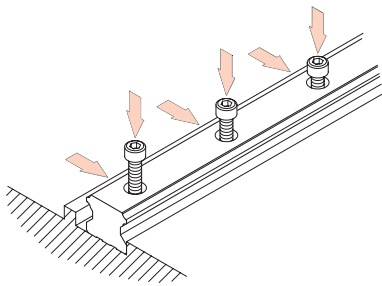

4) Tighten clamping screws one after another in order to ensure good contact between the rail and the reference edge

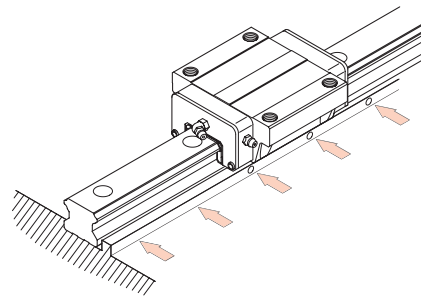

5) Tighten rail mounting bolts in three stages using a torque wrench until the specified torque is reached

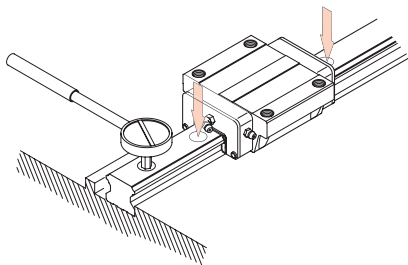

6) Assemble the second rail in the same way as the first

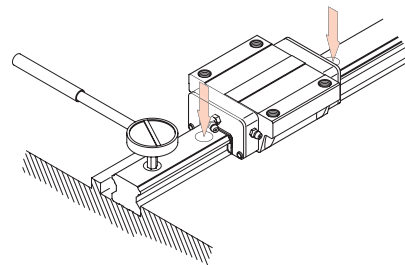

2.8.1.3 Assembly of the blocks

- Carefully place carriage on block. Then provisionally tighten carriage mounting bolts.
- Press block against carriage's reference edge and align carriage by tightening clamping screws.
- To assemble carriage evenly, tighten mounting bolts on reference side and following side in turn four times.

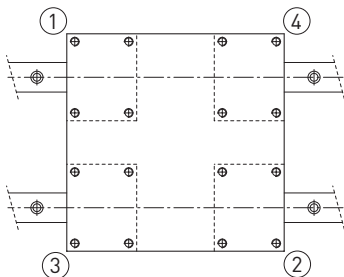

2.8.2 Assembly of rails with reference edge without clamp

To ensure that the reference and following rails are parallel when not using clamping screws, we would recommend the following methods of assembly. The block is installed as described above.

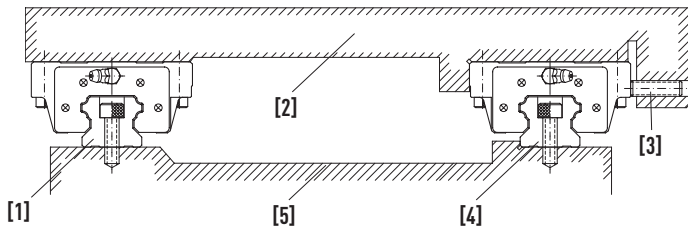

- [1] Following rail
- [2] Carriage
- [3] Block clamping screw
- [4] Reference rail
- [5] Machine bed

2.8.2.1 Assembly of rail on the reference side

Place the guide on the machine bed's mounting surface. Tighten the mounting bolts slightly and then use a vice to press the guide against the reference edge of the machine bed. Then tighten the mounting bolts in turn to the specified torque.

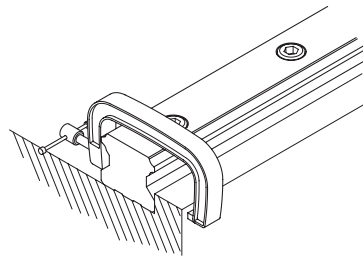

2.8.2.2 Assembly of rail on the following side

Aligning to a straight edge:

Place the straight edge between the guides and align it parallel to the reference edge on the reference side using a dial gauge. Once the guide on the following side is aligned parallel to the reference side, tighten the mounting bolts in turn working from one end of the guide to the other.

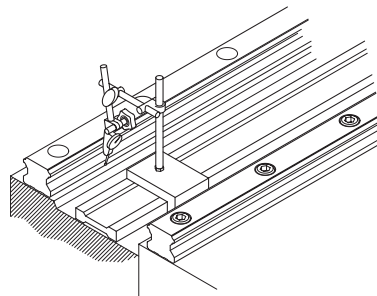

Using a plate:

Install a plate on two blocks on the reference rail. On the following rail, loosely secure a block on the plate. Then fit a dial gauge on the plate and bring the gauge into contact with the side of the following rail's block. Then move the plate from one end to the other and align the following rail parallel to the reference rail. Tighten the mounting bolts in turn.

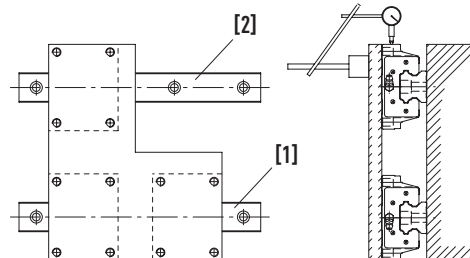

- [1] Reference rail
- [2] Following rail

Linear guideways

General information

Aligning to a reference rail:

When the reference rail is correctly installed, securely fit a plate on two blocks on the reference rail and one of the two blocks on the following rail. Then move the plate from one end of the rails to the other, while tightening the mounting bolts of the following rail.

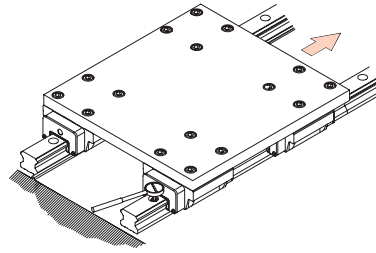

Using a gauge:

Use a special gauge to establish the position of the following rail and tighten the mounting bolts to the specified torque.

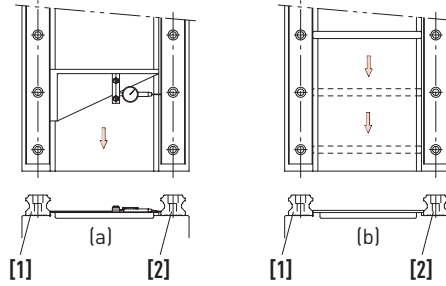

- [1] Reference rail
- [2] Following rail

2.8.3 Assembly of rails without reference edge and without clamp

To ensure that the reference and following rails are parallel even if there is no reference edge on the reference side, we would recommend the following type of assembly. The blocks are installed as described above.

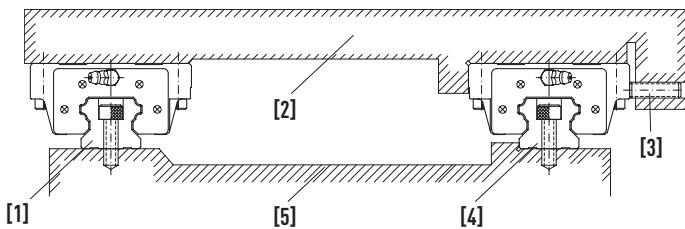

- [1] Following rail
- [2] Carriage
- [3] Block clamping screw
- [4] Following rail
- [5] Machine bed

2.8.3.1 Assembly of rail on the reference side

Aligning to a temporary reference edge:

Closely connect two blocks with a plate. Use an edge on the machine bed to align the rail from one end to the other. To check, move the block and tighten the mounting bolts in turn to the specified torque.

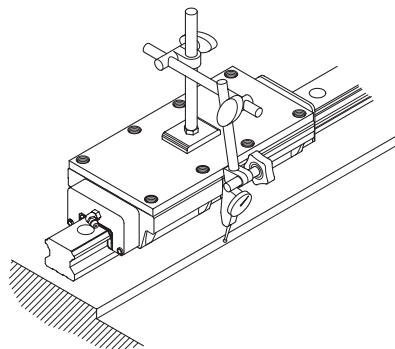

Aligning to a straight edge:

Use a dial gauge on a straight edge to align the rail from one end to the other. Be sure to tighten the mounting bolts in turn.

The following rail is assembled as described under [2.8.2.2, „Assembly of rail on the following side“](#).

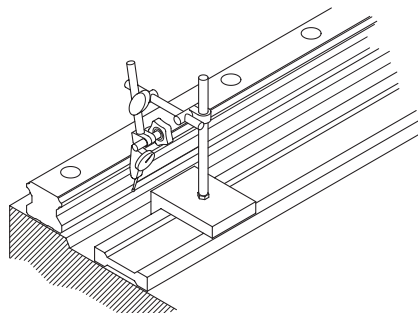

2.8.4 Joint rails

Joint (multi-part) rails must be assembled according to the markings on them. The joints of each section are identified in consecutive alphabetical order as well as by the rail/pair number so that each rail section can be clearly assigned.

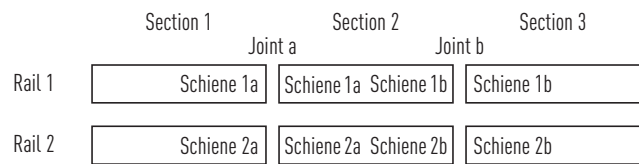

Each joint is printed on the top of the rail. This assists with initial assembly and can be removed at any time using a suitable cleaning agent (e.g. methylated spirit). For paired multi-part rails, the word "Paar" must also be stated in addition to the rail number.

Paar = pair
Schiene = rail

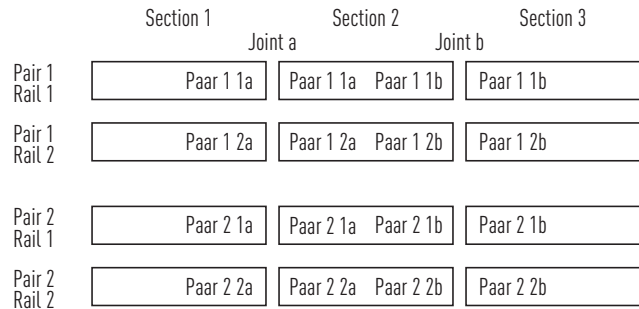

For paired multi-part rails, the butt joints should be staggered.

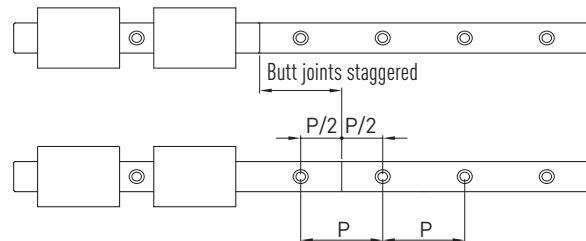

2.8.5 Tightening torques for mounting bolts

Insufficient tightening of the mounting bolts strongly compromises the precision of the linear guideway; the following tightening torques are therefore recommended for the relevant screw sizes.

Table 2.6 Tightening torques of the mounting bolts according to ISO 4762-12.9

Screw size	Torque [Nm]	Screw size	Torque [Nm]
M2	0.6	M8	30
M3	2.0	M10	70
M4	4.0	M12	120
M5	9.0	M14	160
M6	13.0	M16	200

Linear guideways

General information

2.9 Sealing systems

2.9.1 Sealing systems SS, ZZ, DD, KK

The HIWIN end seals firstly prevent the ingress of foreign substances such as dust particles, chips or liquid into the block's ball tracks and secondly reduce the amount of lubricant lost. HIWIN provides various sealing systems for the various ambient conditions of your application. The effectiveness of the end seal impacts directly on the lifetime of the linear guideway and should therefore be taken into account at the design stage and selected to suit the ambient conditions of your application.

SS (standard):

End seal with bottom seal

- For applications with little dirt and dust
- Only minimal increase in displacement forces

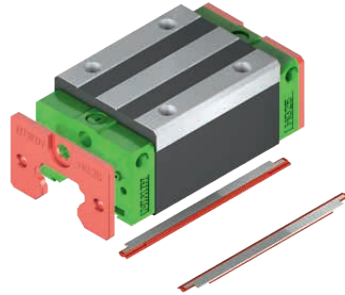

ZZ:

End seal with bottom seal and scraper

- For applications associated with hot chips or sharp-edged particles of dirt
- The scraper protects the end seal and prevents it from being damaged

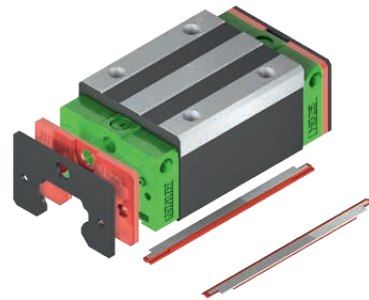

DD:

Double end seal with bottom seal

- For applications associated with a lot of dirt and dust
- The double end seal effectively prevents the ingress of dirt into the block

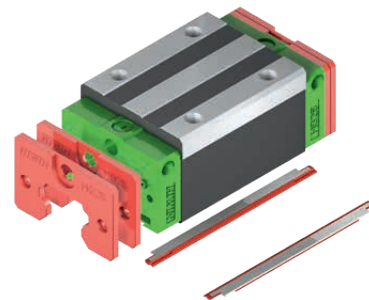

KK:

Double end seal with bottom seal and scraper

- For applications associated with a lot of dirt and dust and hot chips or sharp-edged particles of dirt
- The scraper protects the end seals and prevents them from being damaged

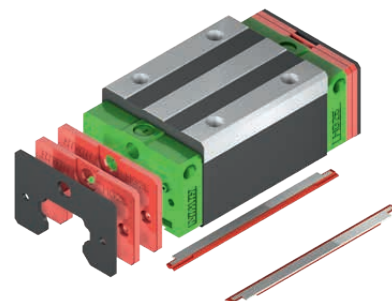

Availability of sealing systems SS, ZZ, DD and KK:

Sealing systems SS, ZZ, DD and KK are available for all series and sizes.

The exceptions are the MG and MG-0 series, for which only the standard sealing system SS is available.

2.9.2 Sealing systems SW and ZWX for optimum dust protection

Sealing systems SW and ZWX allow HIWIN linear guideways to also be used in areas with very high levels of dirt. The sealing systems offer optimum protection against the ingress of dirt, dust and liquid. The end seal is resistant to oils and greases and very resistant to wear.

Properties:

- End seal with double sealing lip
- Bottom seal
- Additional top seal
- Optimized stainless steel scraper

Advantages:

- Optimum dust protection
- Lifetime extended ten-fold
- Longer lubrication intervals
- Lower maintenance costs

SW:

End seal with double sealing lip, bottom seal and additional top seal

- Optimum dust protection
- The additional top seal (not available for all sizes) prevents the ingress of dirt via the top of the rail
- The bottom seal protects against the ingress of dirt on the rail flank

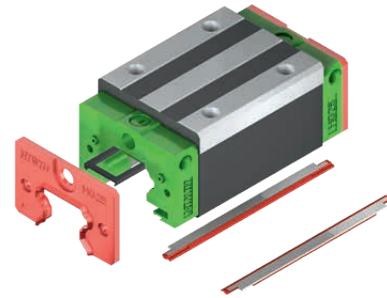

ZWX:

End seal with double sealing lip, bottom seal, additional top seal and optimized scraper

- Optimum dust protection
- The additional top seal (not available for all sizes) prevents the ingress of dirt via the top of the rail
- The bottom seal protects against the ingress of dirt on the rail flank
- The optimized scraper also protects against dirt particles > 0.2 mm in diameter and prevents damage to the end seal.

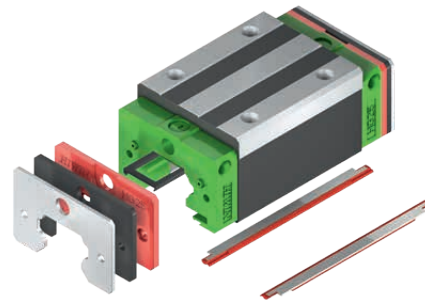

Dust test for sealing systems SW and ZWX

Thorough dust tests have shown that the lifetime with sealing systems SW and ZWX is ten times longer than that with a standard seal in cases of high dust levels.

Test conditions:

- Sealed room in which MDF dust is swirled about
- $v = 1.3 \text{ m/s}$
- Grease lubrication

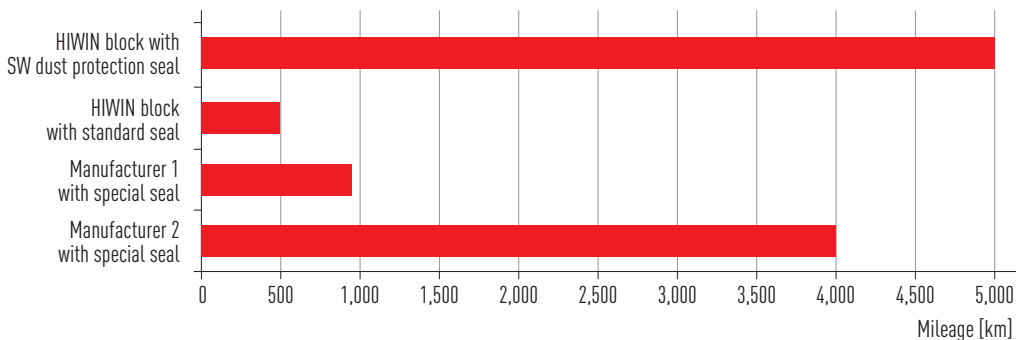

Table 2.7 Availability of sealing systems SW and ZWX

Series	Sizes							
	15	20	25	30	35	45	55	65
HG	●	● ■	● ■	● ■	● ■	● ■	● ■	● ■
CG	● ■	● ■	● ■	● ■	● ■	● ■		
RG	—	—	—	—	—	● ■	● ■	● ■

● Sealing system SW
■ Sealing system ZWX

Linear guideways

General information

2.10 SynchMotion™ technology

The innovative SynchMotion™ technology reduces contact between the rolling elements and with the block. Like the ball cage of a standard ball bearing, the rolling elements are kept a defined distance from one another using SynchMotion™ technology. Reciprocal friction, as is produced in standard linear guideways, is therefore prevented and synchronous fluctuations are greatly reduced. No uncontrolled ball movements occur, even at high speeds. SynchMotion™ technology also improves the transport of lubricant within the block and the storage of lubricant.

Advantages:

- Improved synchronous performance
- Optimised for high travel speeds
- Improved lubrication properties
- Less running noise
- Higher dynamic load capacities

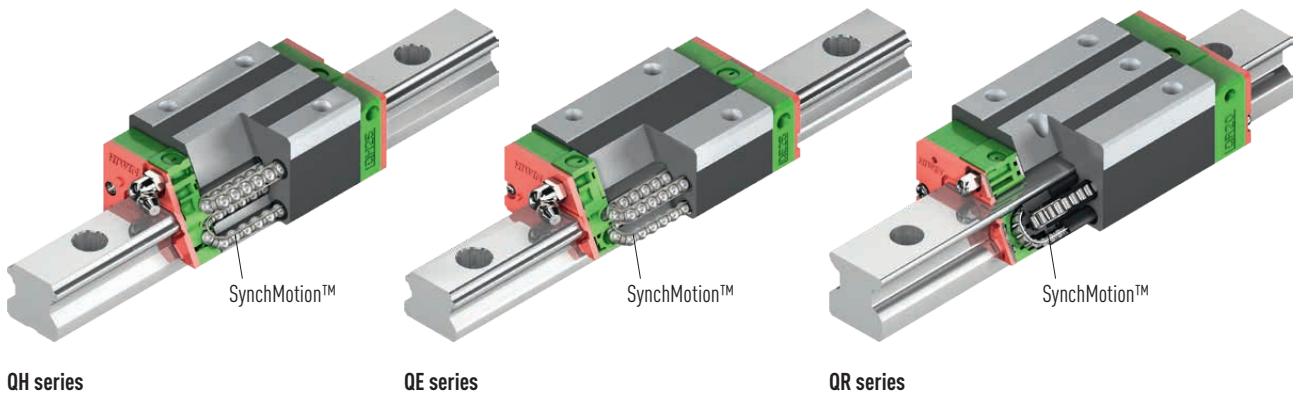

Table 2.8 Availability of SynchMotion™ technology for HIWIN linear guideways

Series	Sizes									
	15	20	21	25	27	30	35	45	55	65
QH	●	●	—	●	—	●	●	●	—	—
QE	●	●	—	●	—	●	●	—	—	—
QW	—	—	●	—	●	—	●	—	—	—
QR	—	—	—	●	—	●	●	●	—	—

Blocks with SynchMotion™ technology come in identical sizes, are compatible with the HG, EG, WE and RG blocks, are fitted on the standard rail and are very easy to interchange.

2.11 Heat-resistant linear guideways

“Solid steel” blocks with steel deflection systems are deployed for permanent use at temperatures in excess of 80 °C. The standard end seals are replaced by heat-resistant seals and the plastic cover caps on the rail with brass caps.

Special properties:

- Good resistance to temperature
- Operating temperature up to 150 °C
- Temperature peaks up to 180 °C.

Areas of use:

- Devices for heat treatment
- Welding devices
- Devices for the production of glass
- Devices for use in vacuums

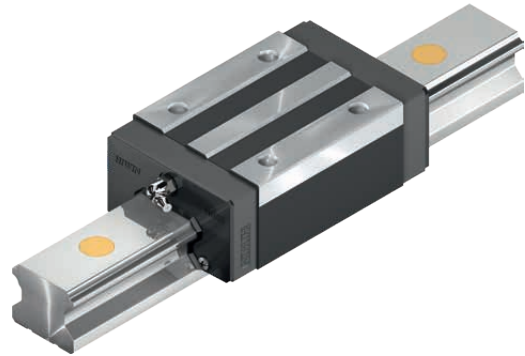

Table 2.9 Series with steel deflection system option

Series	Sizes
HG	15, 20, 25, 30, 35, 45, 55, 65
EG	20, 25
MGN	7, 9, 12, 15
MGW	12, 15

Order code: Add the “/SE” identifier to the order code for the steel deflection system option. Refer to structure of order codes in the chapter for the individual series. HG: from [Page 29](#), EG: from [Page 47](#), MG: from [Page 91](#)

Sample order:

HG **W** **25** **C** **C** **ZA** **H** **ZZ** **SE**

Linear guideways

General information

2.12 HIWIN coatings for linear guideways

2.12.1 HIWIN coating HICOAT CZS

2.12.1.1 Characteristics

HICOAT CZS is a very thin zinc coating that offers a very good corrosion protection, even on radii and chamfers. Smaller bare parts stay protected by the cathodic corrosion protection. Compared with uncoated pieces this leads to significantly higher periods of use. The CZS coating is available for the HG, EG and CG series.

Specific features

- Very good corrosion protection
- Free of Cr(VI)
- One-piece and multi-part rails are available from stock
- Preservation of rail ends with zinc spray (details see below)
- A possible interaction between coating, ambient medium and lubricant should be tested in each individual case

Technical data

- Salt spray test according to DIN EN ISO 9227 (with unloaded rail): 300 hours
- Maximum rail length (single-piece): 4.0 meters

2.12.1.2 Order code for CZS coatings

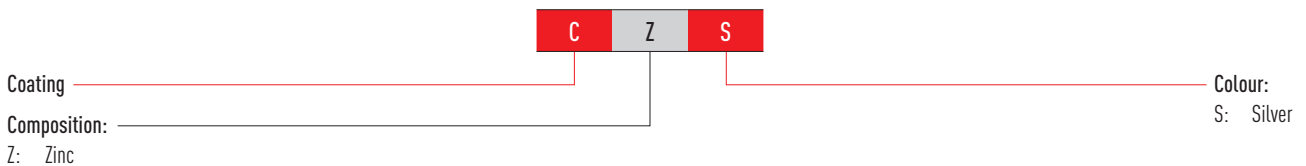

2.12.1.3 Corrosion test

In this test CZS coated profile rails were compared with an uncoated profile rail.



New rail with CZS coating



Rail with CZS coating – after 6 months of outdoor storage



Rail with CZS coating – after 99 hours of salt spray test (acc. to DIN EN ISO 9227)



Uncoated rail – after 4 hours of salt spray test

2.12.1.4 Rail ends

The rail ends are preserved with zinc spray. To achieve a reliable corrosion protection even in the uncoated rail ends, a high-quality zinc spray (zinc content 99 %) is used. The rail ends of one-piece rails and the outer ends of multi-part rails are preserved with zinc spray about 2 mm beyond the cutting edge as shown in the adjacent picture. The ends of jointed rails are supplied with greased, uncoated surfaces.

Note: The mounting holes, as well as the process-related contact points on the bottom side of the rail, can have lower coating thicknesses or sporadic uncoated areas. Generally the inner surfaces of the blocks are not coated.

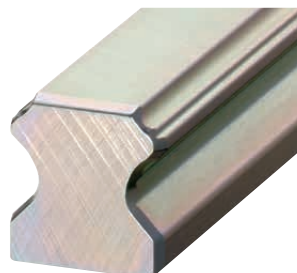

2.12.2 HIWIN coating HICOAT CTS

2.12.2.1 Characteristics

HICOAT CTS is a thin layer chrome coating that offers good corrosion protection and a very high wear protection. The high wear protection results from the extraordinary hardness of the coating. The CTS coating is free of Cr(VI) and suitable for use in food stuffs. It is available for the HG, EG, CG and WE series.

Specific features

- Very good wear protection
- Good corrosion protection
- Free of Cr(VI)
- One-piece rails are available from stock (preservation of rail ends with zinc spray, details see below)
- Multi-part rails are delivered with coated rail ends (longer delivery time)
- Suitable for use in food stuffs

Technical data

- Salt spray test according to DIN EN ISO 9227 (with unloaded rail): 96 hours
- Maximum rail length (single-piece): 4.0 meters

2.12.2.2 Order code for CTS coatings

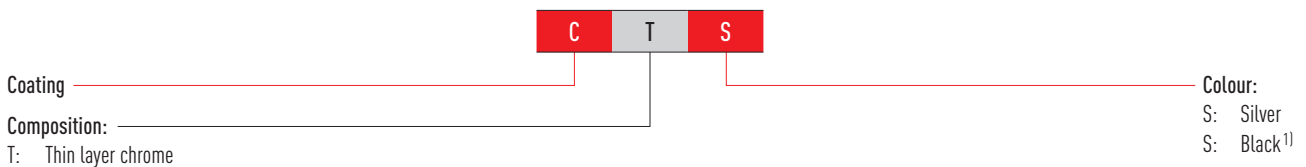

¹⁾ Longer delivery time, not suitable for use in food stuffs, as containing Cr(VI)

2.12.2.3 Corrosion test

In this test CTS coated profile rails were compared with an uncoated profile rail.



New rail with CTS coating



Rail with CTS coating – after one month of outdoor storage



Rail with CTS coating – after 22 hours of salt spray test (acc. to DIN EN ISO 9227)



Uncoated rail – after 4 hours of salt spray test

2.12.2.4 Rail ends

The rail ends of one-piece rails are preserved with zinc spray as shown in the adjacent picture. To achieve a reliable corrosion protection even in the uncoated rail ends, a high-quality zinc spray (zinc content 99 %) is used. Multi-part rails are delivered with coated rail ends (longer delivery time).

Note: The mounting holes can have lower coating thicknesses or sporadic uncoated areas. Generally the inner surfaces of the blocks are not coated.



Linear guideways

General information

2.12.3 Order code for coated linear guideways

Order code for linear guideway (fully assembled)

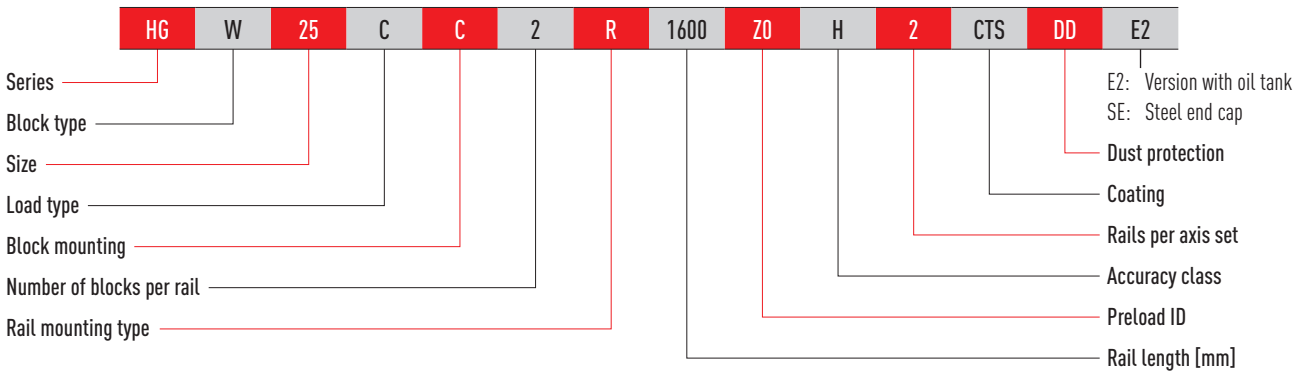

Order code for block (unmounted)

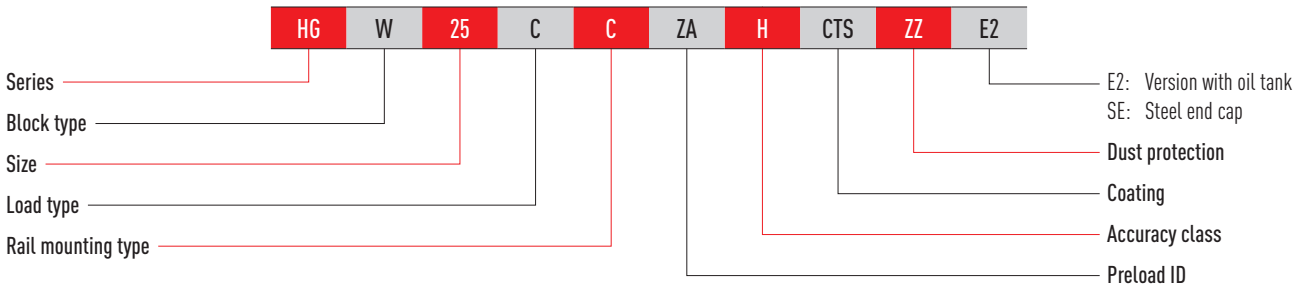

Order code for rail (unmounted)

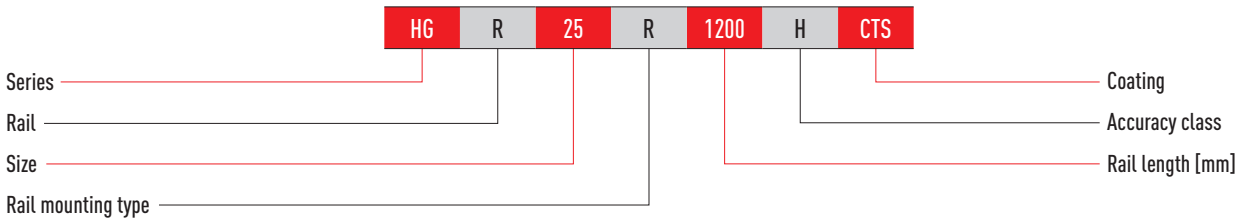

3. Linear guideways

3.1 HG and QH series

3.1.1 Properties of the linear guideways, series HG and QH

The HIWIN linear guideways of the HG series with four ball tracks are designed for high loads and rigidities. Due to the 45° arrangement of the ball tracks the HG series can equally take loads from all directions. Low displacement forces and a high efficiency are further features of the HG series. The ball retainers prevent the balls from falling out when the block is pulled off the rail during assembly.

The models of the QH series with SynchMotion™ technology offer all the advantages of the standard series HG. Controlled movement of the balls at a defined distance also results in improved synchronous performance, higher reliable travel speeds, extended lubrication intervals and less running noise. Since the installation dimensions of the QH blocks are identical to those of the HG blocks, they are also fitted on the HGR standard rail and can therefore be interchanged with ease. For more information, refer to [Page 24](#).

3.1.2 Design of the HG/QH series

- 4-row recirculation ball bearing guide
- 45° contact angle of ball tracks
- Ball retainers prevent the balls from falling out when the block is removed
- Various sealing variants depending on the field of application
- 6 options for connecting grease nipple or lubrication adapter
- SynchMotion™ technology (QH series)

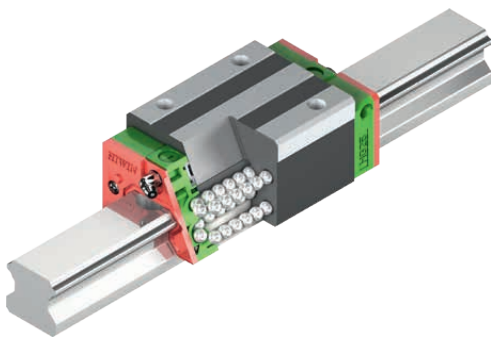

Design of the HG series

Advantages:

- Zero play
- Interchangeable
- High accuracy
- High loading capacity in all loading directions
- Low friction losses even with preload thanks to optimized ball tracks and 2-point contact

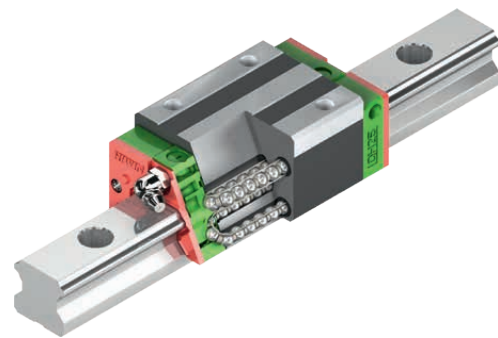

Design of the QH series

Additional advantages of QH series:

- Improved synchronous performance
- Optimized for higher travel speeds
- Extended lubrication intervals
- Less running noise
- Higher dynamic load capacities

3.1.3 Order codes for the HG/QH series

For HG/QH linear guideways, a distinction is made between fully assembled and unmounted models. The dimensions of both models are the same. The main difference is that the block and rail in the unmounted models can be freely interchanged. Block and rail can be ordered separately and fitted by the customer. Their accuracy extends to class P.

Linear guideways

HG and QH series

Order code for linear guideway (fully assembled)

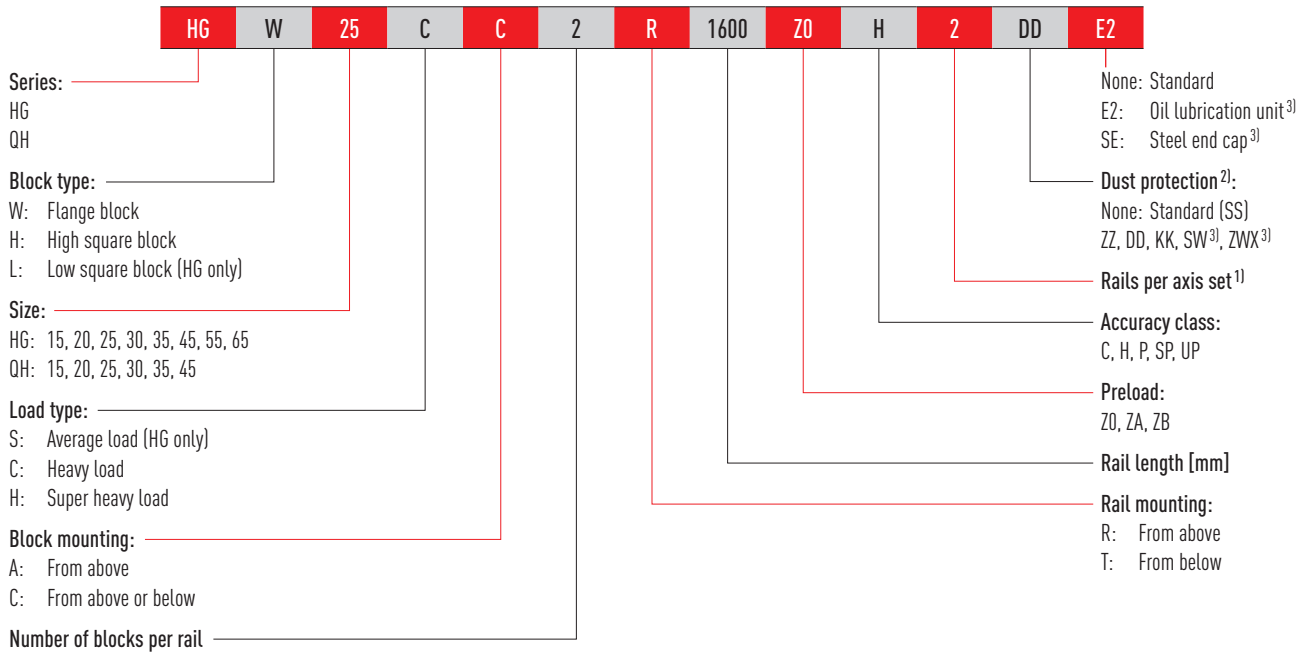

Order code for block (unmounted)

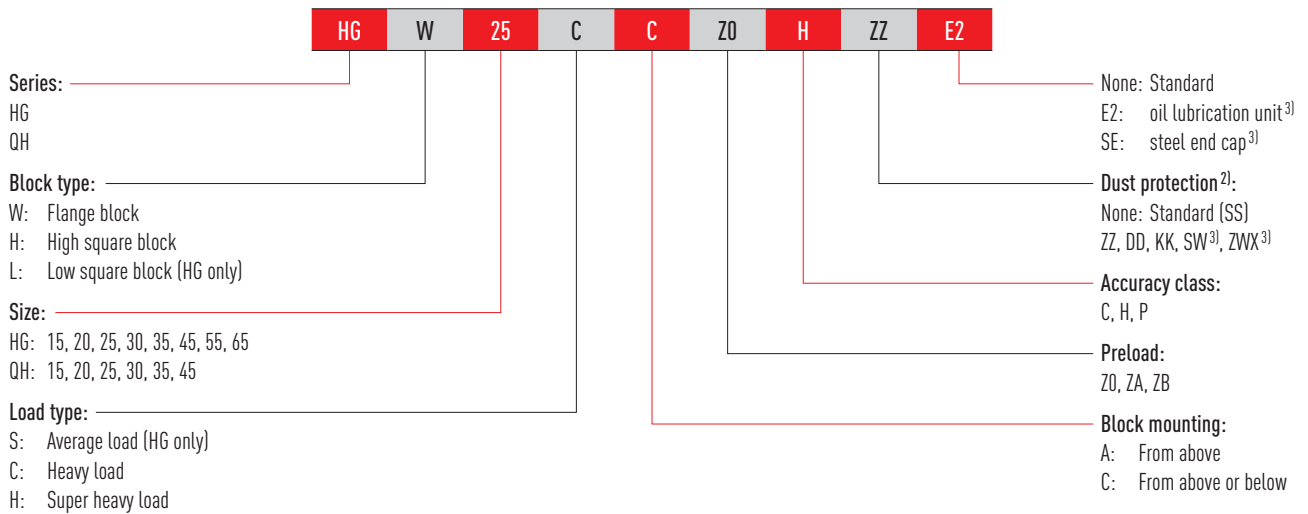

Order code for rail (unmounted)

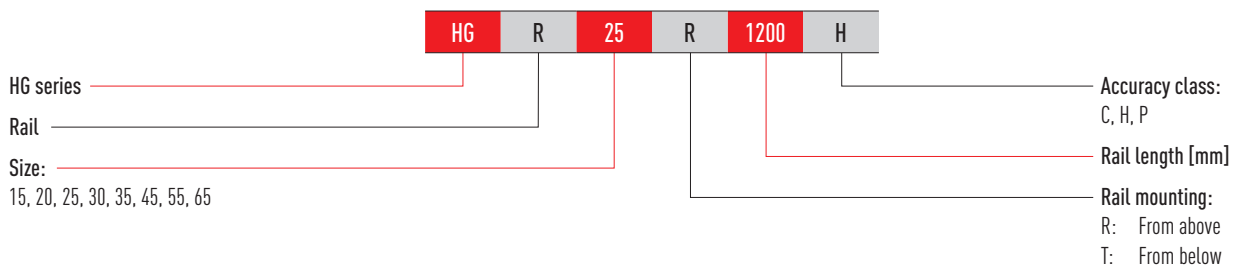

Note:

¹⁾ The figure 2 is also a quantity, i.e. one item of the above-mentioned article consists of a pair of rails. No number is specified for individual rails.

By default multi-part rails are delivered with staggered butt joints.

²⁾ You will find an overview of the individual sealing systems on [Page 22](#)

³⁾ Not available for QH

3.1.4 Block types

HIWIN provides square and flange blocks for its linear guideways. Given their low height and larger mounting surface, flange blocks are better suited to large loads.

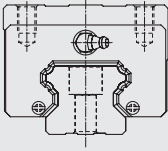
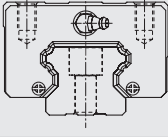
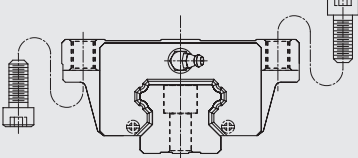
Type	Series/size	Structure	Height [mm]	Typical application
High square type	HGH-CA HGH-HA		28 – 90	<ul style="list-style-type: none"> ○ Machining centres ○ NC lathes ○ Grinding machines ○ Precision milling machines ○ High-performance cutting machines ○ Automation technology ○ Transport technology ○ Measuring technology ○ Machines and equipment requiring high positioning accuracy
Low square type	HGL-CA HGL-HA		24 – 70	
Flange type	HGW-CC HGW-HC		24 – 90	

¹⁾ Optional version on request

3.1.5 Rail types

In addition to rails with standard fastening from above, HIWIN also provides rails for fastening from below.

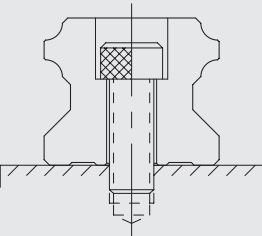
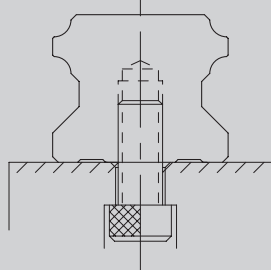
Fastening from above	Fastening from below
	
HGR_R	HGR_T

Linear guideways

HG and QH series

3.1.6 Preload

Definition

Every rail type can be preloaded based on the size of the balls. The curve shows that the rigidity doubles at higher preload. The HG/QH series offers three standard preload classes for various applications and conditions.

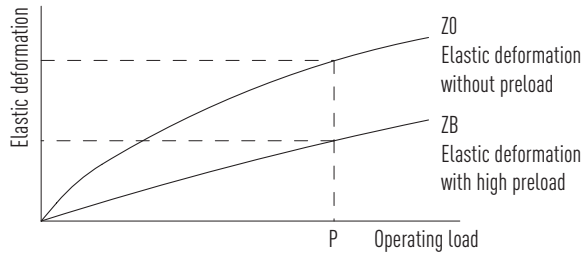

Preload ID

Table 3.3 Preload ID				
ID	Preload		Application	Sample applications
Z0	Light preload	$0 - 0.02 C_{dyn}$	Constant load direction, little vibration, lower accuracy needed	<ul style="list-style-type: none"> ○ Transport technology ○ Automatic packaging machines ○ X-Y axis in industrial machines ○ Welding machines
ZA	Medium preload	$0.05 - 0.07 C_{dyn}$	High accuracy needed	<ul style="list-style-type: none"> ○ Machining centres ○ Z axes for industrial machines ○ Eroding machines ○ NC lathes ○ Precision X-Y tables ○ Measuring technology
ZB	High preload	above $0.1 C_{dyn}$	High rigidity needed, vibration and impact	<ul style="list-style-type: none"> ○ Machining centres ○ Grinding machines ○ NC lathes ○ Horizontal and vertical milling machines ○ Z axis of machine tools ○ High-performance cutting machines

3.1.7 Load ratings and torques

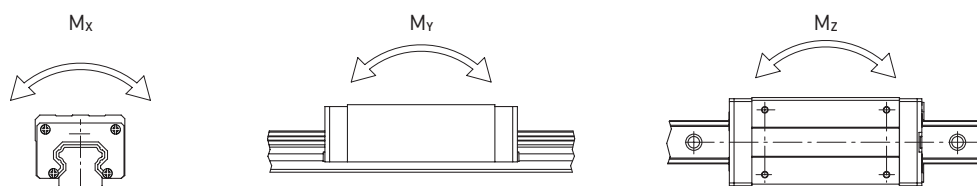

Table 3.4 Load ratings and torques for series HG/QH

Series/size	Dynamic load rating C_{dyn} [N] ¹⁾	Static load rating C_0 [N]	Dynamic moment [Nm]			Static moment [Nm]		
			M_x	M_y	M_z	M_{0x}	M_{0y}	M_{0z}
HG_15C	11,380	16,970	76	67	67	120	100	100
QH_15C	13,880	14,360	90	84	84	100	80	80
HG_20S	12,190	16,110	99	61	61	130	80	80
HG_20C	17,750	27,760	178	126	126	270	200	200
QH_20C	23,080	25,630	231	171	171	260	190	190
HG_20H	21,180	35,900	208	203	203	350	350	350
QH_20H	27,530	31,670	268	230	230	310	270	270
HG_25S	18,650	24,290	239	123	123	310	160	160
HG_25C	26,480	36,490	301	240	240	420	330	330
QH_25C	31,780	33,680	361	294	294	390	310	310
HG_25H	32,750	49,440	374	379	379	560	570	570
QH_25H	39,300	43,620	451	410	410	500	450	450
HG_30C	38,740	52,190	494	396	396	660	530	530
QH_30C	46,490	48,170	588	491	491	600	500	500
HG_30H	47,270	69,160	600	630	630	880	920	920
QH_30H	56,720	65,090	722	623	623	830	890	890
HG_35C	49,520	69,160	832	577	577	1,160	810	810
QH_35C	60,520	63,840	1,019	720	720	1,070	760	760
HG_35H	60,210	91,630	1,011	918	918	1,540	1,400	1,400
QH_35H	73,590	86,240	1,233	1,135	1,135	1,450	1,330	1,330
HG_45C	77,570	102,710	1,497	1,169	1,169	1,980	1,550	1,550
QH_45C	89,210	94,810	1,723	1,295	1,295	1,830	1,380	1,380
HG_45H	94,540	136,460	1,825	1,857	1,857	2,630	2,680	2,680
QH_45H	108,720	128,430	2,097	2,041	2,041	2,470	2,410	2,410
HG_55C	114,440	148,330	2,843	2,039	2,039	3,690	2,640	2,640
HG_55H	139,350	196,200	3,464	3,242	3,242	4,880	4,570	4,570
HG_65C	163,630	215,330	5,049	3,245	3,245	6,650	4,270	4,270
HG_65H	208,360	303,130	6,449	5,068	5,068	9,380	7,380	7,380

¹⁾ Dynamic load rating for travel distance of 50,000 m

Linear guideways

HG and QH series

3.1.8 Rigidity

Rigidity depends on preload. Formula [F 3.1](#) can be used to determine deformation depending on rigidity.

F 3.1

$$\delta = \frac{P}{k}$$

δ Deformation [μm]
 P Operating load [N]
 k Rigidity [N/ μm]

Load class	Series/ size	Rigidity depending on preload		
		Z0	ZA	ZB
Average load	HG_20S	130	170	190
Heavy load	HG_15C	200	260	290
	QH_15C	180	230	260
	HG_20C	250	320	360
	QH_20C	230	290	320
	HG_25C	300	390	440
	QH_25C	270	350	400
	HG_30C	370	480	550
	QH_30C	330	430	500
	HG_35C	410	530	610
	QH_35C	370	480	550
	HG_45C	510	660	750
	QH_45C	460	590	680
	HG_55C	620	800	910
	HG_65C	760	980	1,120
Super heavy load	HG_20H	310	400	460
	QH_20H	280	360	410
	HG_25H	390	510	580
	QH_25H	350	460	520
	HG_30H	480	620	710
	QH_30H	430	560	640
	HG_35H	530	690	790
	QH_35H	480	620	710
	HG_45H	650	850	970
	QH_45H	590	770	870
	HG_55H	790	1,030	1,180
	HG_65H	1,030	1,330	1,520

Unit: N/ μm

3.1.9 Dimensions of the HG/QH blocks

3.1.9.1 HGH/QHH

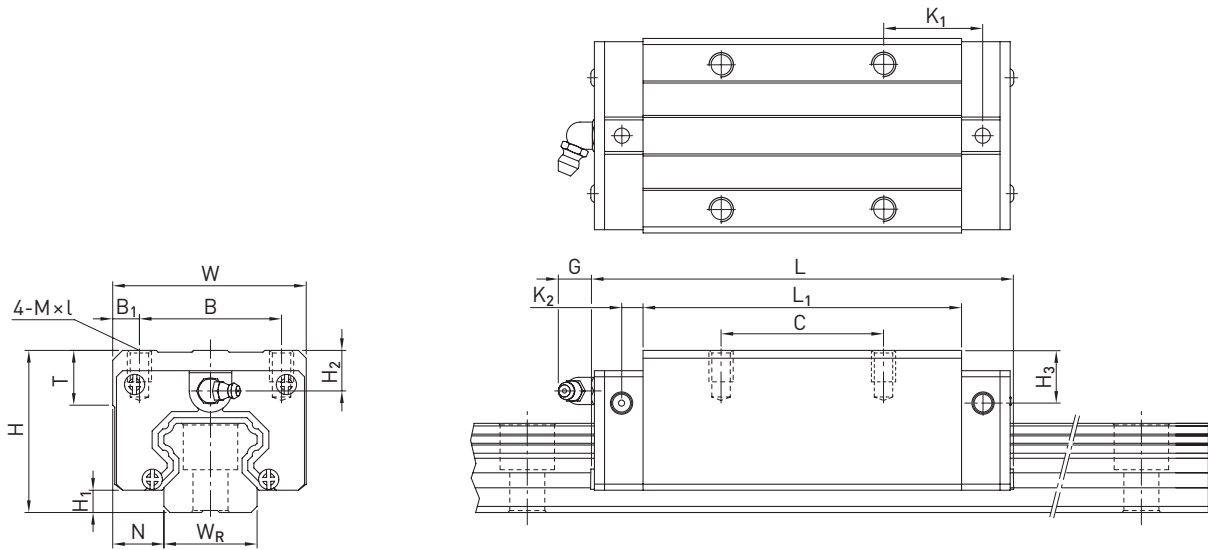

Table 3.6 Dimensions of the block

Series/ size	Installation dimensions [mm]			Dimensions of the block [mm]													Load ratings [N]		Weight [kg]
	H	H ₁	N	W	B	B ₁	C	L ₁	L	K ₁	K ₂	G	M × l	T	H ₂	H ₃	C _{dyn}	C ₀	
HGH15CA	28	4.3	9.5	34	26	4.0	26	39.4	61.4	10.00	4.85	5.3	M4 × 5	6.0	7.95	7.7	11,380	16,970	0.18
QHH15CA	28	4.0	9.5	34	26	4.0	26	39.4	61.4	10.00	5.00	5.3	M4 × 5	6.0	7.95	8.2	13,880	14,360	0.18
HGH20CA	30	4.6	12.0	44	32	6.0	36	50.5	77.5	12.25	6.00	12.0	M5 × 6	8.0	6.00	6.0	17,750	27,760	0.30
HGH20HA							50	65.2	92.2	12.60							21,180	35,900	0.39
QHH20CA	30	4.6	12.0	44	32	6.0	36	50.5	76.7	11.75	6.00	12.0	M5 × 6	8.0	6.00	6.0	23,080	25,630	0.29
QHH20HA							50	65.2	91.4	12.10							27,530	31,670	0.38
HGH25CA	40	5.5	12.5	48	35	6.5	35	58.0	84.0	15.70	6.00	12.0	M6 × 8	8.0	10.00	9.0	26,480	36,490	0.51
HGH25HA							50	78.6	104.6	18.50							32,750	49,440	0.69
QHH25CA	40	5.5	12.5	48	35	6.5	35	58.0	83.4	15.70	6.00	12.0	M6 × 8	8.0	10.00	9.0	31,780	33,680	0.50
QHH25HA							50	78.6	104.0	18.50							39,300	43,620	0.68
HGH30CA	45	6.0	16.0	60	40	10.0	40	70.0	97.4	20.25	6.00	12.0	M8 × 10	8.5	9.50	13.8	38,740	52,190	0.88
HGH30HA							60	93.0	120.4	21.75							47,270	69,160	1.16
QHH30CA	45	6.0	16.0	60	40	10.0	40	70.0	97.4	19.50	6.25	12.0	M8 × 10	8.5	9.50	9.0	46,490	48,170	0.87
QHH30HA							60	93.0	120.4	21.75							56,720	65,090	1.15
HGH35CA	55	7.5	18.0	70	50	10.0	50	80.0	112.4	20.60	7.00	12.0	M8 × 12	10.2	16.00	19.6	49,520	69,160	1.45
HGH35HA							72	105.8	138.2	22.50							60,210	91,630	1.92
QHH35CA	55	7.5	18.0	70	50	10.0	50	80.0	113.6	19.00	7.50	12.0	M8 × 12	10.2	15.50	13.5	60,520	63,840	1.44
QHH35HA							72	105.8	139.4	20.90							73,590	86,240	1.90
HGH45CA	70	9.5	20.5	86	60	13.0	60	97.0	139.4	23.00	10.00	12.9	M10 × 17	16.0	18.50	30.5	77,570	102,710	2.73
HGH45HA							80	128.8	171.2	28.90							94,540	136,460	3.61
QHH45CA	70	9.2	20.5	86	60	13.0	60	97.0	139.4	23.00	10.00	12.9	M10 × 17	16.0	18.50	20.0	89,210	94,810	2.72
QHH45HA							80	128.8	171.2	29.09							108,720	128,430	3.59
HGH55CA	80	13.0	23.5	100	75	12.5	75	117.7	166.7	27.35	11.00	12.9	M12 × 18	17.5	22.00	29.0	114,440	148,330	4.17
HGH55HA							95	155.8	204.8	36.40							139,350	196,200	5.49
HGH65CA	90	15.0	31.5	126	76	25.0	70	144.2	200.2	43.10	14.00	12.9	M16 × 20	25.0	15.00	15.0	163,630	215,330	7.00
HGH65HA							120	203.6	259.6	47.80							208,360	303,130	9.82

¹⁾ 98.8 for version SE; ²⁾ 121.8 for version SE

For dimensions of the rail see Page 38, for standard and optional lubrication adapters see Page 128.

Linear guideways

HG and QH series

3.1.9.2 HGL

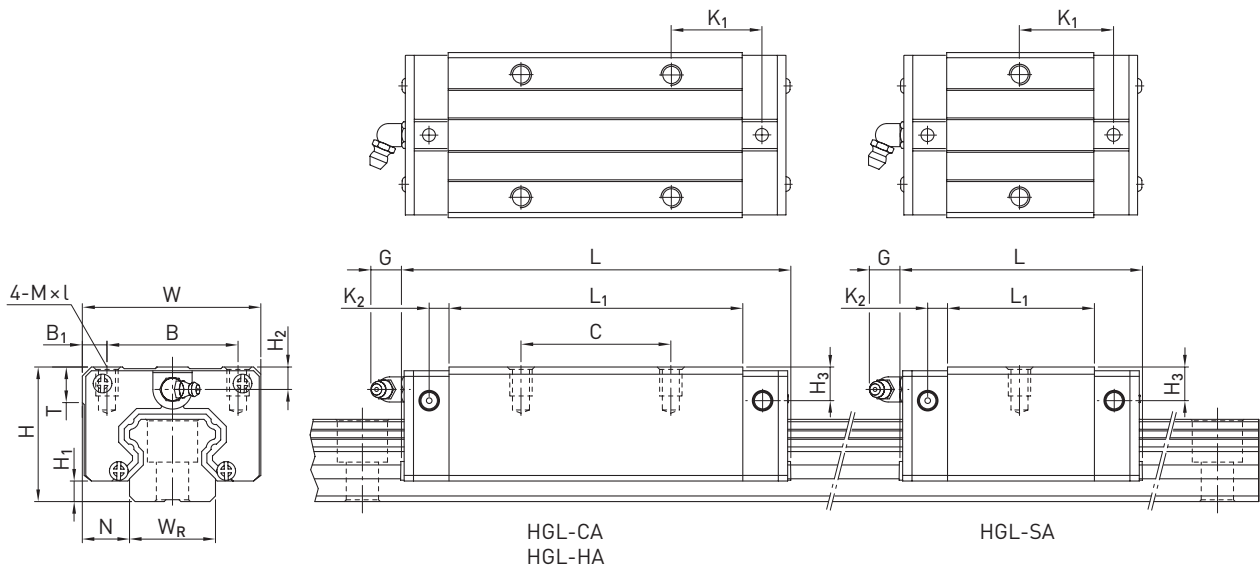

Table 3.7 Dimensions of the block

Series/ size	Installation dimensions [mm]			Dimensions of the block [mm]													Load ratings [N]		Weight [kg]
	H	H ₁	N	W	B	B ₁	C	L ₁	L	K ₁	K ₂	G	M × l	T	H ₂	H ₃	C _{dyn}	C ₀	
HGL15CA	24	4.3	9.5	34	26	4.0	26	39.4	61.4	10.00	4.85	5.3	M4 × 4	6.0	3.95	3.7	11,380	16,970	0.14
HGL25SA	36	5.5	12.5	48	35	6.5	—	38.2	64.2	23.20	6.00	12.0	M6 × 6	8.0	6.00	5.0	18,650	24,290	0.32
HGL25CA							35	58.0	84.0	15.70							26,480	36,490	0.42
HGL25HA							50	78.6	104.6	18.50							32,750	49,440	0.57
HGL30CA	42	6.0	16.0	60	40	10.0	40	70.0	97.4 ¹⁾	20.25	6.00	12.0	M8 × 10	8.5	6.50	10.8	38,740	52,190	0.78
HGL30HA							60	93.0	120.4 ²⁾	21.75							47,270	69,160	1.03
HGL35CA	48	7.5	18.0	70	50	10.0	50	80.0	112.4	20.60	7.00	12.0	M8 × 12	10.2	9.00	12.6	49,520	69,160	1.14
HGL35HA							72	105.8	138.2	22.50							60,210	91,630	1.52
HGL45CA	60	9.5	20.5	86	60	13.0	60	97.0	139.4	23.00	10.00	12.9	M10 × 17	16.0	8.50	20.5	77,570	102,710	2.08
HGL45HA							80	128.8	171.2	28.90							94,540	136,460	2.75
HGL55CA	70	13.0	23.5	100	75	12.5	75	117.7	166.7	27.35	11.00	12.9	M12 × 18	17.5	12.00	19.0	114,440	148,330	3.25
HGL55HA							95	155.8	204.8	36.40							139,350	196,200	4.27

¹⁾ 98.8 for version SE; ²⁾ 121.8 for version SE

For dimensions of the rail see Page 38, for standard and optional lubrication adapters see Page 128.

3.1.9.3 HGW/QHW

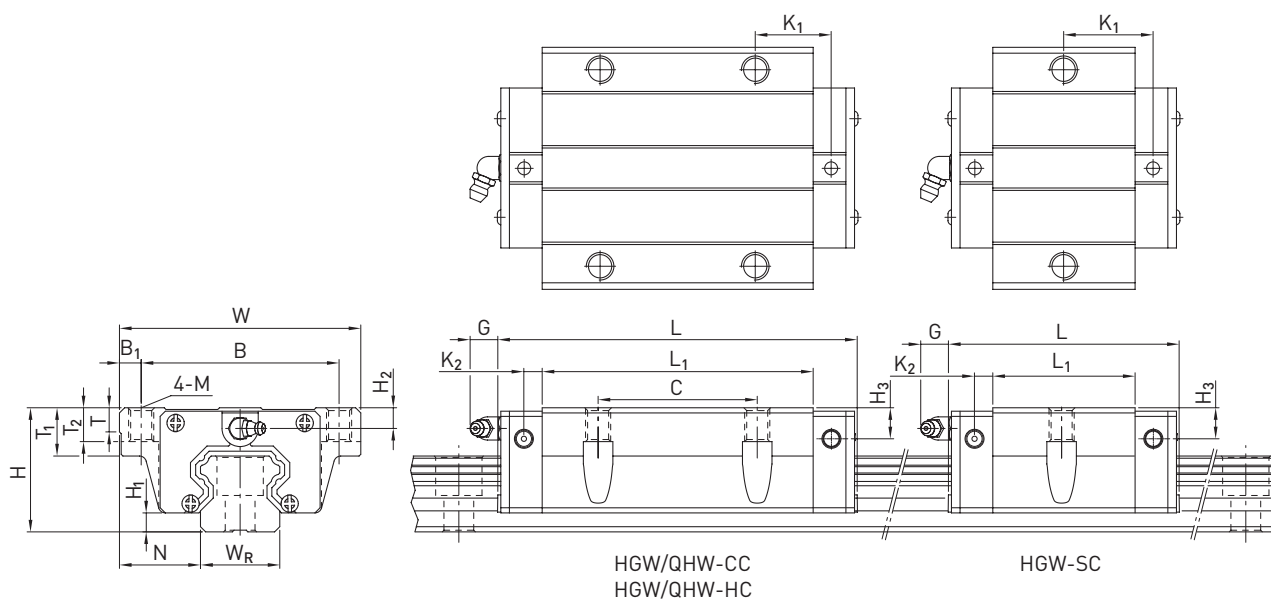

Table 3.8 Dimensions of the block

Series/ size	Installation dimensions [mm]			Dimensions of the block [mm]																Load ratings [N]		Weight [kg]		
	H	H ₁	N	W	B	B ₁	C	L ₁	L	K ₁	K ₂	M	G	T	T ₁	T ₂	H ₂	H ₃	C _{dyn}	C ₀				
HGW15CC	24	4.3	16.0	47	38	4.5	30	39.4	61.4	8.00	4.85	M5	5.3	6.0	8.9	7.0	3.95	3.7	11,380	16,970	0.17			
QHW15CC	24	4.0	16.0	47	38	4.5	30	39.4	61.4	8.00	5.00	M5	5.3	6.0	8.9	7.0	3.95	4.2	13,880	14,360	0.17			
HGW20SC	30	4.6	21.5	63	53	5.0	—	29.5	54.3	19.65	6.00	M6	12.0	8.0	10.0	9.5	6.00	6.0	12,190	16,110	0.28			
HGW20CC							40	50.5	77.5	10.25												17,750	27,760	0.40
HGW20HC							—	65.2	92.2	17.60												21,180	35,900	0.52
QHW20CC	30	4.6	21.5	63	53	5.0	40	50.5	76.7	9.75	6.00	M6	12.0	8.0	10.0	9.5	6.00	6.0	23,080	25,630	0.40			
QHW20HC							—	65.2	91.4	17.10												27,530	31,670	0.52
HGW25SC	36	5.5	23.5	70	57	6.5	—	38.2	64.2	23.20	6.00	M8	12.0	8.0	14.0	10.0	6.00	5.0	18,650	24,290	0.42			
HGW25CC							45	58.0	84.0	10.70												26,480	36,490	0.59
HGW25HC							—	78.6	104.6	21.00												32,750	49,440	0.80
QHW25CC	36	5.5	23.5	70	57	6.5	45	58.0	83.4	10.70	6.00	M8	12.0	8.0	14.0	10.0	6.00	5.0	31,780	33,680	0.59			
QHW25HC							—	78.6	104.0	21.00												39,300	43,620	0.80
HGW30CC	42	6.0	31.0	90	72	9.0	52	70.0	97.4 ¹⁾	14.25	6.00	M10	12.0	8.5	16.0	10.0	6.50	10.8	38,740	52,190	1.09			
HGW30HC							—	93.0	120.4 ²⁾	25.75												47,270	69,160	1.44
QHW30CC	42	6.0	31.0	90	72	9.0	52	70.0	97.4	13.50	6.25	M10	12.0	8.5	16.0	10.0	6.50	6.0	46,490	48,170	1.09			
QHW30HC							—	93.0	120.4	25.75												56,720	65,090	1.44
HGW35CC	48	7.5	33.0	100	82	9.0	62	80.0	112.4	14.60	7.00	M10	12.0	10.1	18.0	13.0	9.00	12.6	49,520	69,160	1.56			
HGW35HC							—	105.8	138.2	27.50												60,210	91,630	2.06
QHW35CC	48	7.5	33.0	100	82	9.0	62	80.0	113.6	13.00	7.50	M10	12.0	10.1	18.0	13.0	8.50	6.5	60,520	63,840	1.56			
QHW35HC							—	105.8	139.4	25.90												73,590	86,240	2.06
HGW45CC	60	9.5	37.5	120	100	10.0	80	97.0	139.4	13.00	10.00	M12	12.9	15.1	22.0	15.0	8.50	20.5	77,570	102,710	2.79			
HGW45HC							—	128.8	171.2	28.90												94,540	136,460	3.69
QHW45CC	60	9.2	37.5	120	100	10.0	80	97.0	139.4	13.00	10.00	M12	12.9	15.1	22.0	15.0	8.50	10.0	89,210	94,810	2.79			
QHW45HC							—	128.8	171.2	28.90												108,720	128,430	3.69
HGW55CC	70	13.0	43.5	140	116	12.0	95	117.7	166.7	17.35	11.00	M14	12.9	17.5	26.5	17.0	12.00	19.0	114,440	148,330	4.52			
HGW55HC							—	155.8	204.8	36.40												139,350	196,200	5.96
HGW65CC	90	15.0	53.5	170	142	14.0	110	144.2	200.2	23.10	14.00	M16	12.9	25	37.5	23.0	15.00	15.0	163,630	215,330	9.17			
HGW65HC							—	203.6	259.6	52.80												208,360	303,130	12.89

¹⁾ 98.8 for version SE; ²⁾ 121.8 for version SE

For dimensions of the rail see Page 38, for standard and optional lubrication adapters see Page 128.

Linear guideways

HG and QH series

3.1.10 Dimensions of the HG rail

The HG rails are used for both the HG and QH blocks.

3.1.10.1 Dimensions of HGR_R

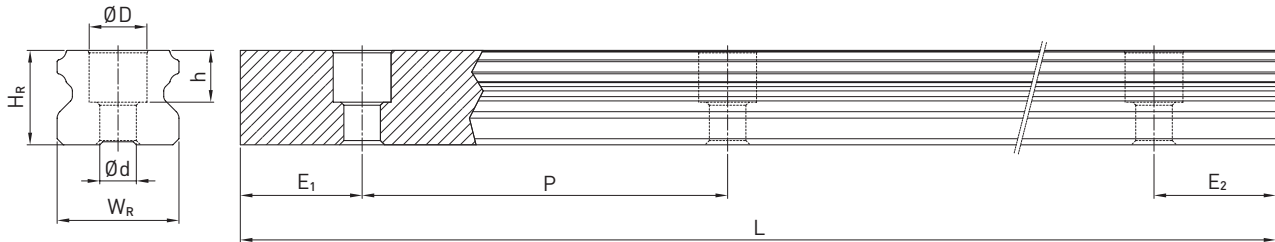

Table 3.9 Dimensions of rail HGR_R

Series/ size	Assembly screw for rail [mm]	Dimensions of rail [mm]						Max. length [mm]	Max. length $E_1 = E_2$ [mm]	Min. length [mm]	$E_{1/2}$ min [mm]	$E_{1/2}$ max [mm]	Weight [kg/m]
		W_R	H_R	D	h	d	P						
HGR15R	M4 × 20	15	15.0	7.5	5.3	4.5	60	4,000	3,900	132	6	54	1.45
HGR20R	M5 × 20	20	17.5	9.5	8.5	6.0	60	4,000/5,600 ¹⁾	3,900/5,520 ¹⁾	134	7	53	2.21
HGR25R	M6 × 25	23	22.0	11.0	9.0	7.0	60	4,000/5,600 ¹⁾	3,900/5,520 ¹⁾	136	8	52	3.21
HGR30R	M8 × 30	28	26.0	14.0	12.0	9.0	80	4,000/5,600 ¹⁾	3,920/5,520 ¹⁾	178	9	71	4.47
HGR35R	M8 × 35	34	29.0	14.0	12.0	9.0	80	4,000/5,600 ¹⁾	3,920/5,520 ¹⁾	178	9	71	6.30
HGR45R	M12 × 45	45	38.0	20.0	17.0	14.0	105	4,000/5,600 ¹⁾	3,885/5,460 ¹⁾	234	12	93	10.41
HGR55R	M14 × 55	53	44.0	23.0	20.0	16.0	120	4,000/5,600 ¹⁾	3,840/5,440 ¹⁾	268	14	106	15.08
HGR65R	M16 × 65	63	53.0	26.0	22.0	18.0	150	4,000/5,600 ¹⁾	3,750/5,350 ¹⁾	330	15	135	21.18

¹⁾ Optional version on request

3.1.10.2 Dimensions of HGR_T

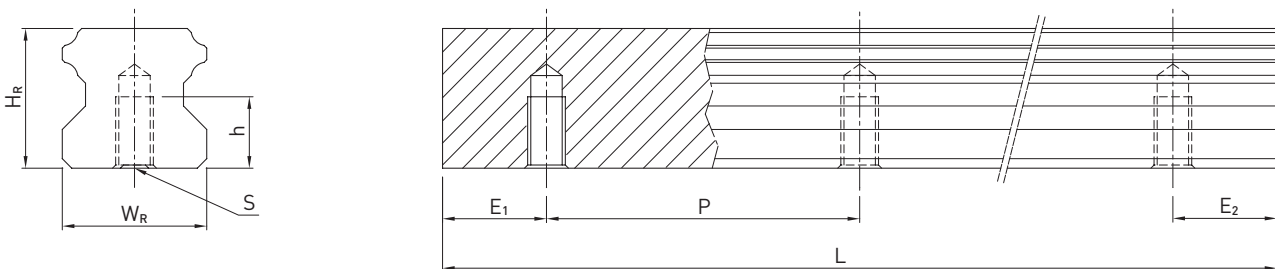

Table 3.10 Dimensions of rail HGR_T

Series/ size	Dimensions of rail [mm]					Max. length [mm]	Max. length $E_1 = E_2$ [mm]	Min. length [mm]	$E_{1/2}$ min [mm]	$E_{1/2}$ max [mm]	Weight [kg/m]
	W_R	H_R	S	h	P						
HGR15T	15	15.0	M5	8	60	4,000	3,900	132	6	54	1.48
HGR20T	20	17.5	M6	10	60	4,000	3,900	134	7	53	2.29
HGR25T	23	22.0	M6	12	60	4,000	3,900	136	8	52	3.35
HGR30T	28	26.0	M8	15	80	4,000	3,920	178	9	71	4.67
HGR35T	34	29.0	M8	17	80	4,000	3,920	178	9	71	6.51
HGR45T	45	38.0	M12	24	105	4,000	3,885	234	12	93	10.87
HGR55T	53	44.0	M14	24	120	4,000	3,840	268	14	106	15.67
HGR65T	63	53.0	M20 ¹⁾	30	150	4,000	3,750	330	15	135	21.73

¹⁾ Deviating from DIN 645

Note:

1. The tolerance for E is +0.5 to -1 mm for standard rails and 0 to -0.3 mm for joints.
2. If the $E_{1/2}$ dimensions are not indicated, the maximum possible number of mounting holes will be determined under consideration of $E_{1/2}$ min.
3. The rails are shortened to the required length. If the $E_{1/2}$ dimensions are not indicated, these will be carried out symmetrically.

3.1.10.3 Calculating the length of rails

HIWIN offers rails in customized lengths. To prevent the risk of the end of the rail becoming unstable, the value E must not exceed half of the distance between the mounting holes (P). At the same time, the value E_{1/2} should be between E_{1/2} min and E_{1/2} max so that the mounting hole does not rupture.

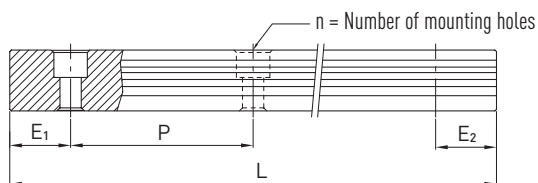

F.3.2

$$L = (n - 1) \times P + E_1 + E_2$$

L Total length of the rail [mm]
n Number of mounting holes
P Distance between two mounting holes [mm]
E_{1/2} Distance from the middle of the last mounting hole to the end of the rail [mm]

3.1.10.4 Tightening torques for mounting bolts

Insufficient tightening of the mounting bolts strongly compromises the precision of the linear guideway; the following tightening torques are therefore recommended for the relevant screw sizes.

Table 3.11 Tightening torques of the mounting bolts according to ISO 4762-12.9

Series/size	Screw size	Torque [Nm]	Series/size	Screw size	Torque [Nm]
HG/QH_15	M4 × 20	4	HG/QH_35	M8 × 35	31
HG/QH_20	M5 × 20	9	HG/QH_35	M10	70
HG/QH_25	M6 × 25	14	HG/QH_45	M12 × 45	120
HG/QH_30	M8 × 30	31	HG_55	M14 × 55	160
HG/QH_30	M10	70	HG_65	M16 × 65	200

3.1.10.5 Cover caps for mounting holes of rails

The cover caps are used to keep the mounting holes free of chips and dirt. The standard plastic caps are provided with each rail. Optional cover caps must be ordered separately.



Table 3.12 Cover caps for mounting holes of rails

Rail	Screw	Article number			Ø D [mm]	Height H [mm]
		Plastic (200 pcs.)	Brass	Steel		
HGR15R	M4	5-002218	5-001344	—	7.5	1.2
HGR20R	M5	5-002220	5-001350	5-001352	9.5	2.5
HGR25R	M6	5-002221	5-001355	5-001357	11.0	2.8
HGR30R	M8	5-002222	5-001360	5-001362	14.0	3.5
HGR35R	M8	5-002222	5-001360	5-001362	14.0	3.5
HGR45R	M12	5-002223	5-001324	5-001327	20.0	4.0
HGR55R	M14	5-002224	5-001330	5-001332	23.0	4.0
HGR65R	M16	5-002225	5-001335	5-001337	26.0	4.0

Linear guideways

HG and QH series

3.1.11 Sealing systems

Various sealing systems are available for HIWIN blocks. You will find an overview on [Page 22](#). The table below shows the total length of the blocks with the different sealing systems. Sealing systems suitable for these sizes are available.

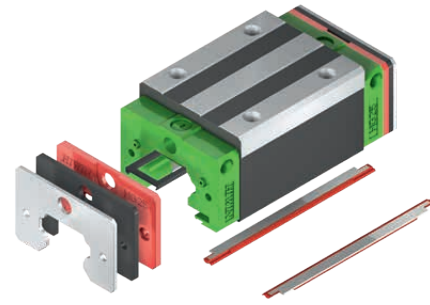

Table 3.13 Total length of blocks with different sealing systems

Series/ size	Total length L					
	SS	DD	ZZ	KK	SW	ZWX
HG_15C	61.4	68.0	69.0	75.6	63.2	—
QH_15C	61.4	68.0	68.4	75.0	—	—
HG_20S	56.5	59.5	57.5	62.5	57.5	61.3
HG_20C	77.5	82.5	82.5	87.5	78.5	82.3
QH_20C	76.7	81.7	81.9	86.9	—	—
HG_20H	92.2	97.5	97.2	102.2	93.2	97.0
QH_20H	91.4	96.4	96.6	101.6	—	—
HG_25C	84.0	89.0	89.0	94.0	85.0	91.8
QH_25C	83.4	88.4	89.4	94.4	—	—
HG_25H	104.6	109.6	109.6	114.6	105.6	112.4
QH_25H	104.4	109.0	110.0	115.0	—	—
HG_30C	97.4	104.8	105.4	112.8	99.0	105.8
QH_30C	97.4	104.8	104.8	112.2	—	—
HG_30H	120.4	127.8	128.4	135.8	122.0	128.8
QH_30H	120.4	127.8	127.8	135.2	—	—
HG_35C	112.4	119.8	120.4	127.8	115.2	122.4
QH_35C	113.6	118.6	119.0	124.0	—	—
HG_35H	138.2	145.6	146.2	153.6	141.0	148.2
QH_35H	139.4	144.4	144.8	149.8	—	—
HG_45C	139.4	149.4	150.0	160.0	140.0	144.8
QH_45C	139.4	146.6	147.2	154.4	—	—
HG_45H	171.2	181.2	181.8	191.8	171.8	176.6
QH_45H	171.2	178.4	179.0	186.2	—	—
HG_55C	166.7	177.1	177.1	187.5	163.7	172.9
HG_55H	204.8	215.2	215.2	225.5	201.8	211.0
HG_65C	200.2	209.2	208.2	217.2	196.2	203.4
HG_65H	259.6	268.6	267.6	276.6	255.6	262.8

Unit: mm

3.1.11.1 Designation of sealing sets

The sealing sets are always supplied along with the assembly material and include the parts needed in addition to the standard seal.

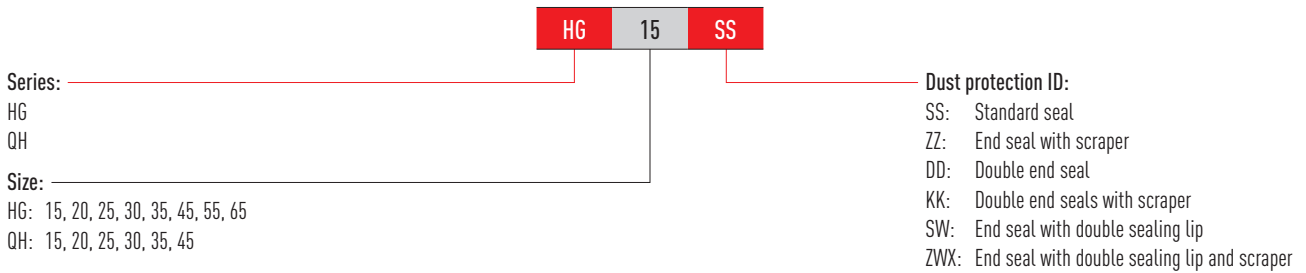

3.1.12 Friction

The table shows the maximum frictional resistance of the individual end seal. Depending on sealing setup (SS, DD, ZZ, KK), the value may have to be multiplied. The values indicated apply to blocks on uncoated rails. Higher friction forces occur on coated rails.

Series/size	Friction force [N]	Series/size	Friction force [N]
HG/QH_15	1.2	HG_45	3.9
HG/QH_20	1.6	QH_45	5.3
HG/QH_25	2.0	HG_55	4.7
HG/QH_30	2.7	HG_65	5.8
HG/QH_35	3.1		

Linear guideways

HG and QH series

3.1.13 Lubrication unit E2

You will find more information about the lubrication unit in the general information in the lubrication unit E2 Section „2.6.3 Oil Lubrication unit E2“ on Page 15.

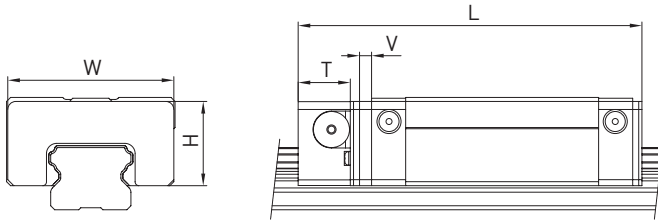

Table 3.15 Dimensions of block with lubrication unit E2

Model	Dimensions of the block [mm]								Oil quantity [cm ³]	Mileage ²⁾ [km]
	W	H	T	V	L _{SS} ¹⁾	L _{ZZ} ¹⁾	L _{DD} ¹⁾	L _{KK} ¹⁾		
HG_15C	32.4	19.5	12.5	3.0	75.4	80.5	82.0	87.1	1.6	2,000
HG_20S	43.0	24.4	13.5	3.5	70.9	73.0	75.0	78.0	3.9	4,000
HG_20C	43.0	24.4	13.5	3.5	93.5	95.6	97.5	100.6	3.9	4,000
HG_20H	43.0	24.4	13.5	3.5	108.2	110.2	112.2	115.2	3.9	4,000
HG_25C	46.4	29.5	13.5	3.5	100.0	102.0	104.0	107.0	5.1	6,000
HG_25H	46.4	29.5	13.5	3.5	120.6	122.6	124.6	127.6	5.1	6,000
HG_30C	58.0	35.0	13.5	3.5	112.9	118.0	119.9	125.0	7.8	8,000
HG_30H	58.0	35.0	13.5	3.5	135.9	141.0	142.9	148.0	7.8	8,000
HG_35C	68.0	38.5	13.5	3.5	127.9	133.4	135.3	140.8	9.8	10,000
HG_35H	68.0	38.5	13.5	3.5	153.7	159.2	161.1	166.6	9.8	10,000
HG_45C	82.0	49.0	16.0	4.5	157.2	162.1	166.1	171.7	18.5	20,000
HG_45H	82.0	49.0	16.0	4.5	189.0	193.9	197.9	203.5	18.5	20,000
HG_55C	97.0	55.5	16.0	4.5	183.9	189.6	193.8	200.0	25.9	30,000
HG_55H	97.0	55.5	16.0	4.5	222.0	227.7	231.9	238.1	25.9	30,000
HG_65C	121.0	69.0	16.0	4.5	219.2	220.7	226.7	229.7	50.8	40,000
HG_65H	121.0	69.0	16.0	4.5	278.6	280.1	286.1	289.1	50.8	40,000

¹⁾ Total length depending on selected dust protection. SS = Standard dust protection

²⁾ Mileage at which the oil tank level should be checked at the very latest

3.1.14 Tolerances depending on accuracy class

The HG and QH series are available in five accuracy classes depending on parallelism between block and rail, height accuracy H and accuracy of width N. The choice of accuracy class is determined by the machine requirements.

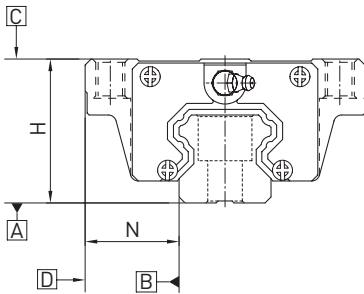

3.1.14.1 Parallelism

Parallelism of stop surfaces D and B of block and parallelism of top of block C to mounting surface A of rail. Ideal linear guideway installation is required, as is a measurement in the centre of the block.

Table 3.16 Tolerance of parallelism between block and rail

Rail length [mm]	Accuracy class				
	C	H	P	SP	UP
- 100	12	7	3	2	2
100 - 200	14	9	4	2	2
200 - 300	15	10	5	3	2
300 - 500	17	12	6	3	2
500 - 700	20	13	7	4	2
700 - 900	22	15	8	5	3
900 - 1100	24	16	9	6	3
1100 - 1500	26	18	11	7	4
1500 - 1900	28	20	13	8	4
1900 - 2500	31	22	15	10	5
2500 - 3100	33	25	18	11	6
3100 - 3600	36	27	20	14	7
3600 - 4000	37	28	21	15	7

Unit: μm

Linear guideways

HG and QH series

3.1.14.2 Accuracy – height and width

Height tolerance of H

Permissible absolute dimension variance of height H, measured between centre of screw-on surface C and underside of rail A, with block in any position on the rail.

Height variance of H

Permissible variance of height H between several blocks on a rail, measured in the same rail position.

Width tolerance of N

Permissible absolute dimension variance of width N, measured between centre of screw-on surfaces D and B, with block in any position on the rail.

Width variance of N

Permissible variance of width N between several blocks on a rail, measured in the same rail position.

Series/size	Accuracy class	Height tolerance of H	Width tolerance of N	Height variance of H	Width variance of N
HG_15, 20 QH_15, 20	C (Normal)	± 0.1	± 0.1	0.02	0.02
	H (High)	± 0.03	± 0.03	0.01	0.01
	P (Precision)	0/− 0.03 ¹⁾ ± 0.015 ²⁾	0/− 0.03 ¹⁾ ± 0.015 ²⁾	0.006	0.006
	SP (Super precision)	0/− 0.015	0/− 0.015	0.004	0.004
	UP (Ultra precision)	0/− 0.008	0/− 0.008	0.003	0.003
HG_25, 30, 35 QH_25, 30, 35	C (Normal)	± 0.1	± 0.1	0.02	0.03
	H (High)	± 0.04	± 0.04	0.015	0.015
	P (Precision)	0/− 0.04 ¹⁾ ± 0.02 ²⁾	0/− 0.04 ¹⁾ ± 0.02 ²⁾	0.007	0.007
	SP (Super precision)	0/− 0.02	0/− 0.02	0.005	0.005
	UP (Ultra precision)	0/− 0.01	0/− 0.01	0.003	0.003
HG_45, 55 QH_45	C (Normal)	± 0.1	± 0.1	0.03	0.03
	H (High)	± 0.05	± 0.05	0.015	0.02
	P (Precision)	0/− 0.05 ¹⁾ ± 0.025 ²⁾	0/− 0.05 ¹⁾ ± 0.025 ²⁾	0.007	0.01
	SP (Super precision)	0/− 0.03	0/− 0.03	0.005	0.007
	UP (Ultra precision)	0/− 0.02	0/− 0.02	0.003	0.005
HG_65	C (Normal)	± 0.1	± 0.1	0.03	0.03
	H (High)	± 0.07	± 0.07	0.02	0.025
	P (Precision)	0/− 0.07 ¹⁾ ± 0.035 ²⁾	0/− 0.07 ¹⁾ ± 0.035 ²⁾	0.01	0.015
	SP (Super precision)	0/− 0.05	0/− 0.05	0.007	0.01
	UP (Ultra precision)	0/− 0.03	0/− 0.03	0.005	0.007

Unit: mm

¹⁾ Fully assembled linear guideway

²⁾ Unmounted linear guideway

3.1.14.3 Permissible mounting surface tolerances

Once the requirements relating to the accuracy of the mounting surfaces are met, the good accuracy, rigidity and lifetime of the HG and QH series linear guideways are achieved.

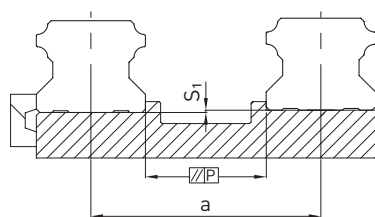

Tolerance for the parallelism of the reference surface (P):

Table 3.18 Maximum tolerance for parallelism (P)

Series/size	Preload class		
	Z0	ZA	ZB
HG/QH_15	25	18	—
HG/QH_20	25	20	18
HG/QH_25	30	22	20
HG/QH_30	40	30	27
HG/QH_35	50	35	30
HG/QH_45	60	40	35
HG_55	70	50	45
HG_65	80	60	55

Unit: μm

Tolerance for the height of the reference surface (S_1)

F 3.3 $S_1 = a \times K$

- S_1 Max. height tolerance [mm]
- a Distance between rails [mm]
- K Coefficient of the height tolerance

Table 3.19 Coefficient of the height tolerance (K)

Series/size	Preload class		
	Z0	ZA	ZB
HG/QH_15	2.6×10^{-4}	1.7×10^{-4}	—
HG/QH_20	2.6×10^{-4}	1.7×10^{-4}	1.0×10^{-4}
HG/QH_25	2.6×10^{-4}	1.7×10^{-4}	1.4×10^{-4}
HG/QH_30	3.4×10^{-4}	2.2×10^{-4}	1.8×10^{-4}
HG/QH_35	4.2×10^{-4}	3.0×10^{-4}	2.4×10^{-4}
HG/QH_45	5.0×10^{-4}	3.4×10^{-4}	2.8×10^{-4}
HG_55	6.0×10^{-4}	4.2×10^{-4}	3.4×10^{-4}
HG_65	7.0×10^{-4}	5.0×10^{-4}	4.0×10^{-4}

Linear guideways

HG and QH series

3.1.15 Shoulder heights and fillets

Imprecise shoulder heights and fillets of mounting surfaces compromise precision and may lead to conflicts with the block or rail profiles. The following shoulder heights and edge profiles must be observed in order to avoid assembly problems.

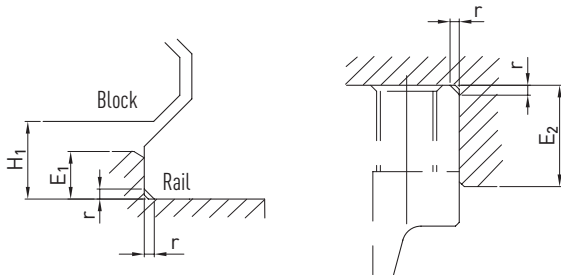

Table 3.20 Shoulder heights and fillets

Series/size	Max. edge radius r	Shoulder height of reference edge of rail E_1	Shoulder height of reference edge of block E_2	Clearance under block H_1
HG_15	0.5	3.0	4.0	4.3
QH_15	0.5	3.0	4.0	4.0
HG/QH_20	0.5	3.5	5.0	4.6
HG/QH_25	1.0	5.0	5.0	5.5
HG/QH_30	1.0	5.0	5.0	6.0
HG/QH_35	1.0	6.0	6.0	7.5
HG/QH_45	1.0	8.0	8.0	9.5
HG_55	1.5	10.0	10.0	13.0
HG_65	1.5	10.0	10.0	15.0

Unit: mm

3.2 EG and QE series

3.2.1 Properties of the linear guideways, series EG and QE

The HIWIN linear guideways of the EG series with four ball tracks have a low installation height, making them ideally suited to applications with a low installation space. Despite this, the EG series has the same properties as the HG series – good loading capacity, low displacement forces and high efficiency. The ball retainers prevent the balls from falling out when the block is pulled off the rail during assembly.

The models of the QE series with SynchMotion™ technology offer all the advantages of the standard series EG. Controlled movement of the balls at a defined distance also results in improved synchronous performance, higher reliable travel speeds, extended lubrication intervals and less running noise. Since the installation dimensions of the QE blocks are identical to those of the EG blocks, they are also fitted on the EGR standard rail and can therefore be interchanged with ease. For more information, refer to [Page 24](#).

3.2.2 Design of the EG/QE series

- 4-row recirculation ball bearing guide
- 45° contact angle of ball tracks
- Ball retainers prevent the balls from falling out when the block is removed
- Various sealing variants depending on the field of application
- 6 options for connecting grease nipple or lubrication adapter
- SynchMotion™ technology (QE series)

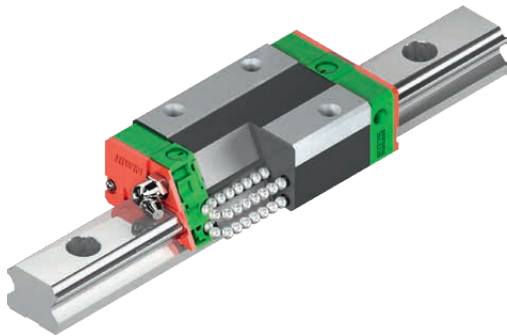

Design of the EG series

Advantages:

- Zero play
- Interchangeable
- High accuracy
- High loading capacity in all loading directions
- Low friction losses even with preload thanks to optimized ball tracks and 2-point contact

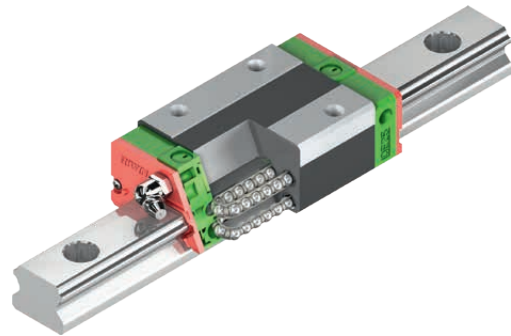

Design of the QE series

Additional advantages of QE series:

- Improved synchronous performance
- Optimized for higher travel speeds
- Extended lubrication intervals
- Less running noise
- Higher dynamic load capacities

3.2.3 Order codes for the EG/QE series

For EG/QE linear guideways, a distinction is made between fully assembled and unmounted models. The dimensions of both models are the same. The main difference is that the block and rail in the unmounted models can be freely interchanged. Block and rail can be ordered separately and fitted by the customer. Their accuracy extends to class P.

Linear guideways

EG and QE series

Order code for linear guideway (fully assembled)

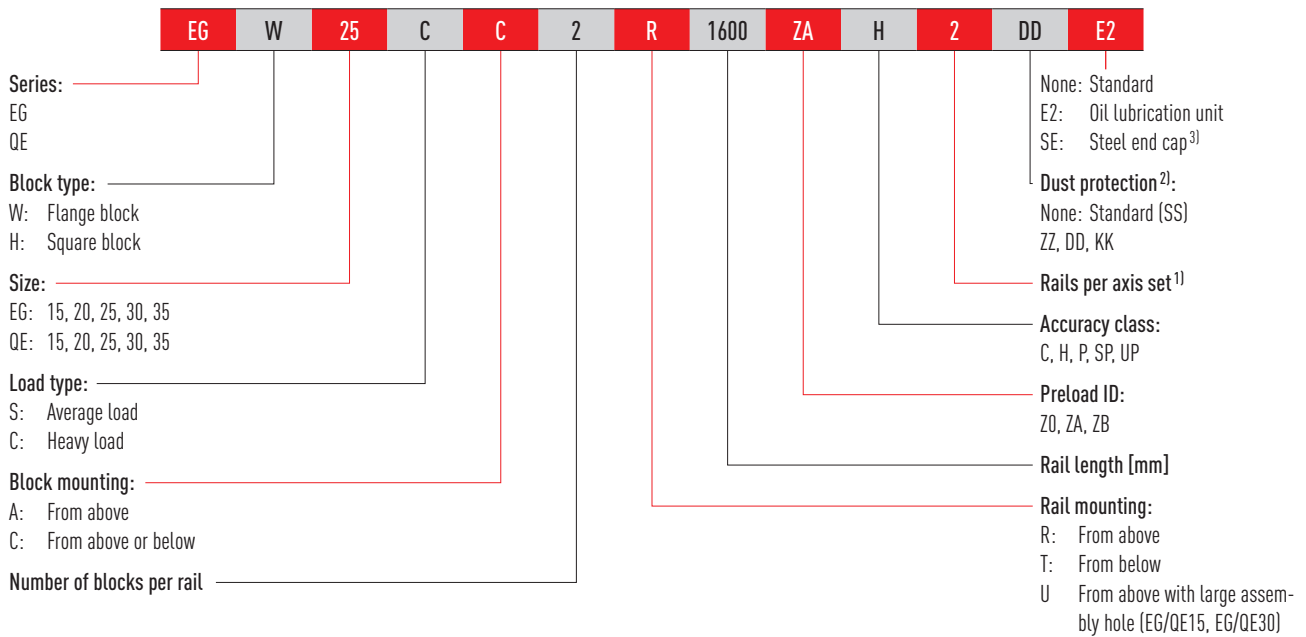

Order code for block (unmounted)

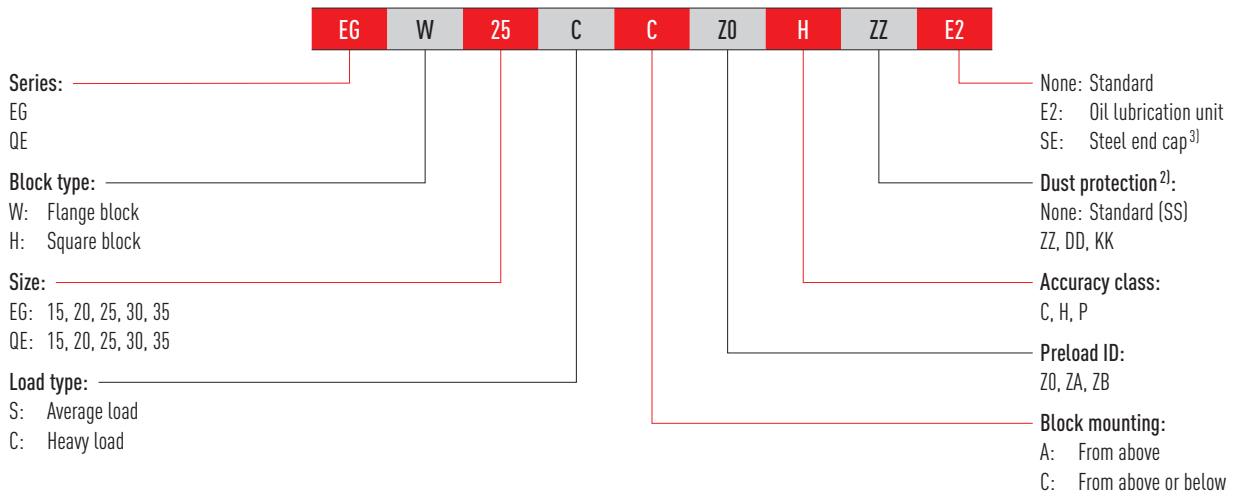

Order code for rail (unmounted)

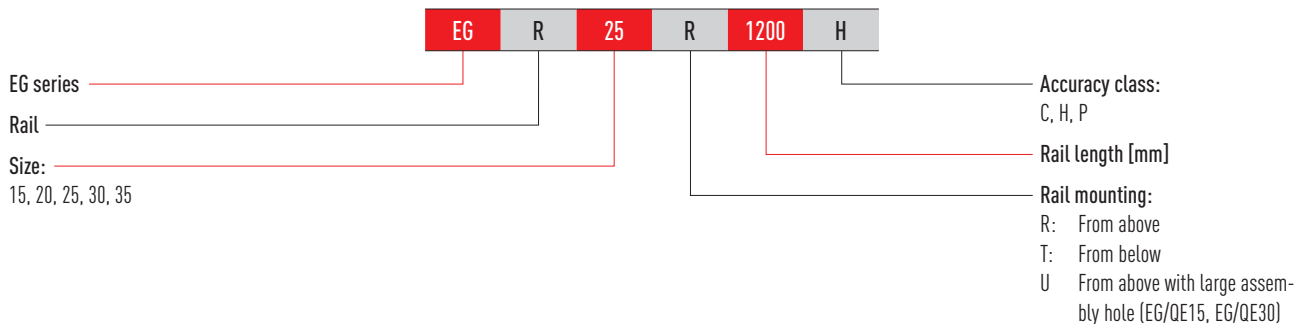

Note:

¹⁾ The figure 2 is also a quantity, i.e. one item of the above-mentioned article consists of a pair of rails. No number is specified for individual rails

By default multi-part rails are delivered with staggered butt joints.

²⁾ You will find an overview of the individual sealing systems on [Page 22](#)

³⁾ Only available for EG 20 and EG 25

3.2.4 Block types

HIWIN provides square and flange blocks for its linear guideways. Given their low height and larger mounting surface, flange blocks are better suited to large loads.

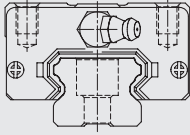
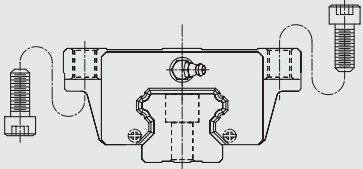
Type	Series/size	Structure	Height [mm]	Typical application
Square type	EGH-SA EGH-CA		24 – 48	<ul style="list-style-type: none"> ○ Machining centres ○ NC lathes ○ Grinding machines ○ Precision milling machines ○ High-performance cutting machines ○ Automation technology ○ Transport technology ○ Measuring technology ○ Machines and equipment requiring high positioning accuracy
Flange type	EGW-SC EGW-CC			

3.2.5 Rail types

In addition to rails with standard fastening from above, HIWIN also provides rails for fastening from below.

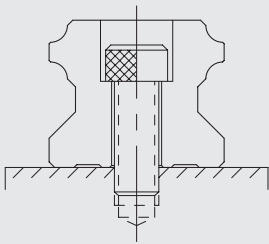
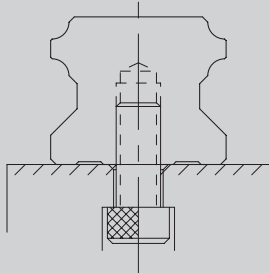
Fastening from above	Fastening from below
	
EGR_R	EGR_T

3.2.6 Preload

Definition

Every rail type can be preloaded based on the size of the balls. The curve shows that the rigidity doubles at higher preload. The EG/QE series offers three standard preload classes for various applications and conditions.

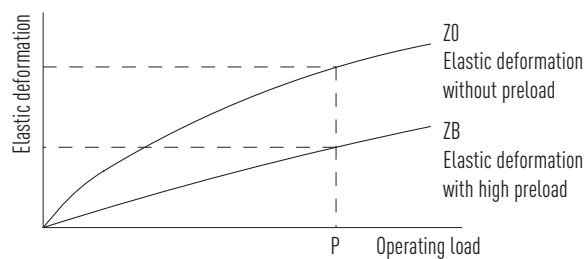

Linear guideways

EG and QE series

Preload ID

ID	Preload		Application	Sample applications
ZO	Light preload	$0 - 0.02 C_{dyn}$	Constant load direction, low impact, low accuracy needed	<ul style="list-style-type: none"> ○ Transport technology ○ Automatic packaging machines ○ X-Y axis in industrial machines ○ Welding machines
ZA	Medium preload	$0.03 - 0.05 C_{dyn}$	High accuracy needed	<ul style="list-style-type: none"> ○ Machining centres ○ Z axes for industrial machines ○ Eroding machines ○ NC lathes ○ Precision X-Y tables ○ Measuring technology
ZB	High preload	$0.06 - 0.08 C_{dyn}$	High rigidity needed, vibration and impact	<ul style="list-style-type: none"> ○ Machining centres ○ Grinding machines ○ NC lathes ○ Horizontal and vertical milling machines ○ Z axis of machine tools ○ High-performance cutting machines

3.2.7 Load ratings and torques

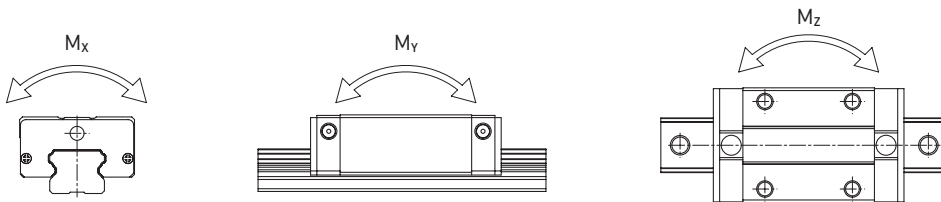

Series/size	Dynamic load rating C_{dyn} [N] ¹⁾	Static load rating C_0 [N]	Dynamic moment [Nm]			Static moment [Nm]		
			M_x	M_y	M_z	M_{0x}	M_{0y}	M_{0z}
EG_15S	5,350	9,400	45	22	22	80	40	40
QE_15S	8,560	8,790	68	29	29	70	30	30
EG_15C	7,830	16,190	62	48	48	130	100	100
QE_15C	12,530	15,280	98	73	73	120	90	90
EG_20S	7,230	12,740	73	34	34	130	60	60
QE_20S	11,570	12,180	123	47	47	130	50	50
EG_20C	10,310	21,130	107	78	78	220	160	160
QE_20C	16,500	20,210	171	122	122	210	150	150
EG_25S	11,400	19,500	134	70	70	230	120	120
QE_25S	18,240	18,900	212	96	96	220	100	100
EG_25C	16,270	32,400	190	160	160	380	320	320
QE_25C	26,030	31,490	305	239	239	370	290	290
EG_30S	16,420	28,100	233	122	122	400	210	210
QE_30S	26,270	27,820	377	169	169	400	180	180
EG_30C	23,700	47,460	339	274	274	680	550	550
QE_30C	37,920	46,630	544	414	414	670	510	510
EG_35S	22,660	37,380	339	187	187	560	310	310
QE_35S	36,390	36,430	609	330	330	610	330	330
EG_35C	33,350	64,840	504	354	354	980	690	690
QE_35C	51,180	59,280	863	648	648	1,000	750	750

¹⁾ Dynamic load rating for travel distance of 50,000 m

3.2.8 Rigidity

Rigidity depends on preload. Formula [F 3.4](#) can be used to determine deformation depending on rigidity.

F 3.4

$$\delta = \frac{P}{k}$$

δ Deformation [µm]
P Operating load [N]
k Rigidity [N/µm]

Table 3.25 Radial rigidity for series EG/QE

Load class	Series/ size	Rigidity depending on preload		
		Z0	ZA	ZB
Average load	EG_15S	105	126	141
	QE_15S	96	115	128
	EG_20S	126	151	168
	QE_20S	116	139	153
	EG_25S	156	187	209
	QE_25S	137	165	184
	EG_30S	184	221	246
	QE_30S	169	203	226
	EG_35S	221	265	295
	QE_35S	214	257	287
Heavy load	EG_15C	172	206	230
	QE_15C	157	187	209
	EG_20C	199	238	266
	QE_20C	183	219	245
	EG_25C	246	296	329
	QE_25C	219	263	293
	EG_30C	295	354	395
	QE_30C	271	326	363
	EG_35C	354	425	474
	QE_35C	333	399	445

Unit: N/µm

Linear guideways

EG and QE series

3.2.9 Dimensions of the EG/QE blocks

3.2.9.1 EGH/QEH

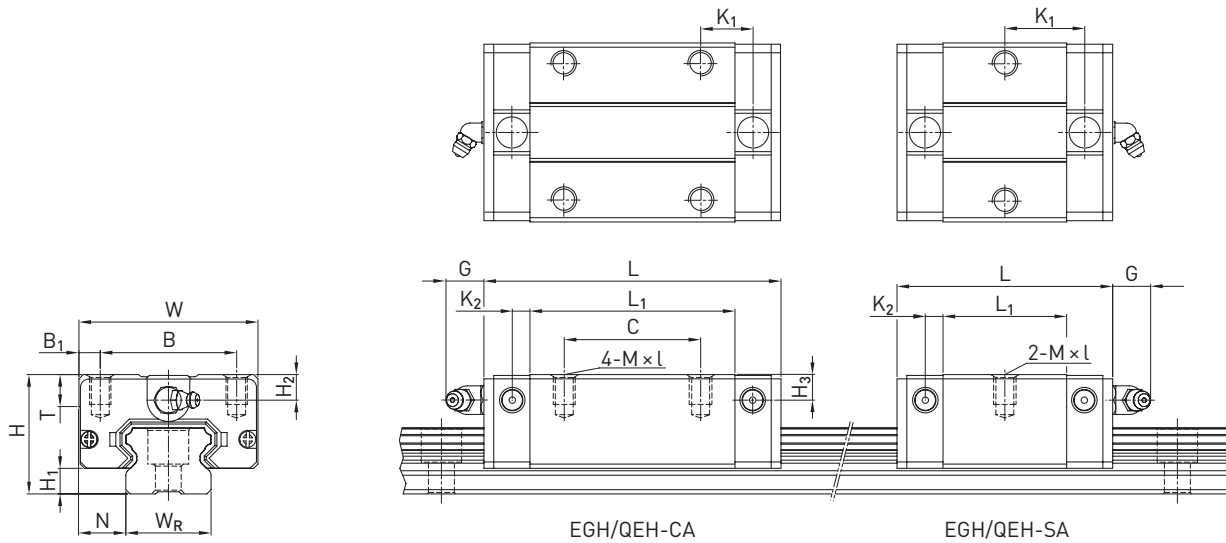

Table 3.26 Dimensions of the block

Series/ size	Installation dimensions [mm]			Dimensions of the block [mm]													Load ratings [N]		Weight [kg]
	H	H ₁	N	W	B	B ₁	C	L ₁	L	K ₁	K ₂	G	M × l	T	H ₂	H ₃	C _{dyn}	C ₀	
EGH15SA	24	4.5	9.5	34	26	4.0	—	23.1	40.1	14.80	3.50	5.7	M4 × 6	6.0	5.5	6.0	5,350	9,400	0.09
EGH15CA							26	39.8	56.8	10.15							7,830	16,190	0.15
QEH15SA	24	4.0	9.5	34	26	4.0	—	23.1	40.1	14.80	3.50	5.7	M4 × 6	6.0	5.5	6.0	8,560	8,790	0.09
QEH15CA							26	39.8	56.8	10.15							12,530	15,280	0.15
EGH20SA	28	6.0	11.0	42	32	5.0	—	29.0	50.0	18.75	4.15	12.0	M5 × 7	7.5	6.0	6.0	7,230	12,740	0.15
EGH20CA							32	48.1	69.1	12.30							10,310	21,130	0.24
QEH20SA	28	6.0	11.0	42	32	5.0	—	29.0	50.0	18.75	4.15	12.0	M5 × 7	7.5	6.0	6.5	11,570	12,180	0.15
QEH20CA							32	48.1	69.1	12.30							16,500	20,210	0.23
EGH25SA	33	7.0	12.5	48	35	6.5	—	35.5	59.1	21.90	4.55	12.0	M6 × 9	8.0	8.0	8.0	11,400	19,500	0.25
EGH25CA							35	59.0	82.6	16.15							16,270	32,400	0.41
QEH25SA	33	6.2	12.5	48	35	6.5	—	35.5	60.1	21.90	5.00	12.0	M6 × 9	8.0	8.0	8.0	18,240	18,900	0.24
QEH25CA							35	59.0	83.6	16.15							26,030	31,490	0.40
EGH30SA	42	10.0	16.0	60	40	10.0	—	41.5	69.5	26.75	6.00	12.0	M8 × 12	9.0	8.0	9.0	16,420	28,100	0.45
EGH30CA							40	70.1	98.1	21.05							23,700	47,460	0.76
QEH30SA	42	10.0	16.0	60	40	10.0	—	41.5	67.5	25.75	6.00	12.0	M8 × 12	9.0	8.0	9.0	26,270	27,820	0.44
QEH30CA							40	70.1	96.1	20.05							37,920	46,630	0.75
EGH35SA	48	11.0	18.0	70	50	10.0	—	45.0	75.0	28.50	7.00	12.0	M8 × 12	10.0	8.5	8.5	22,660	37,380	0.74
EGH35CA							50	78.0	108.0	20.00							33,350	64,840	1.10
QEH35SA	48	11.0	18.0	70	50	10.0	—	51.0	76.0	30.30	6.25	12.0	M8 × 12	10.0	8.5	8.5	36,390	36,430	0.58
QEH35CA							50	83.0	108.0	21.30							51,180	59,280	0.90

For dimensions of rail, see Page 54. for standard and optional lubrication adapter, see Page 128.

3.2.9.2 EGW/QEW

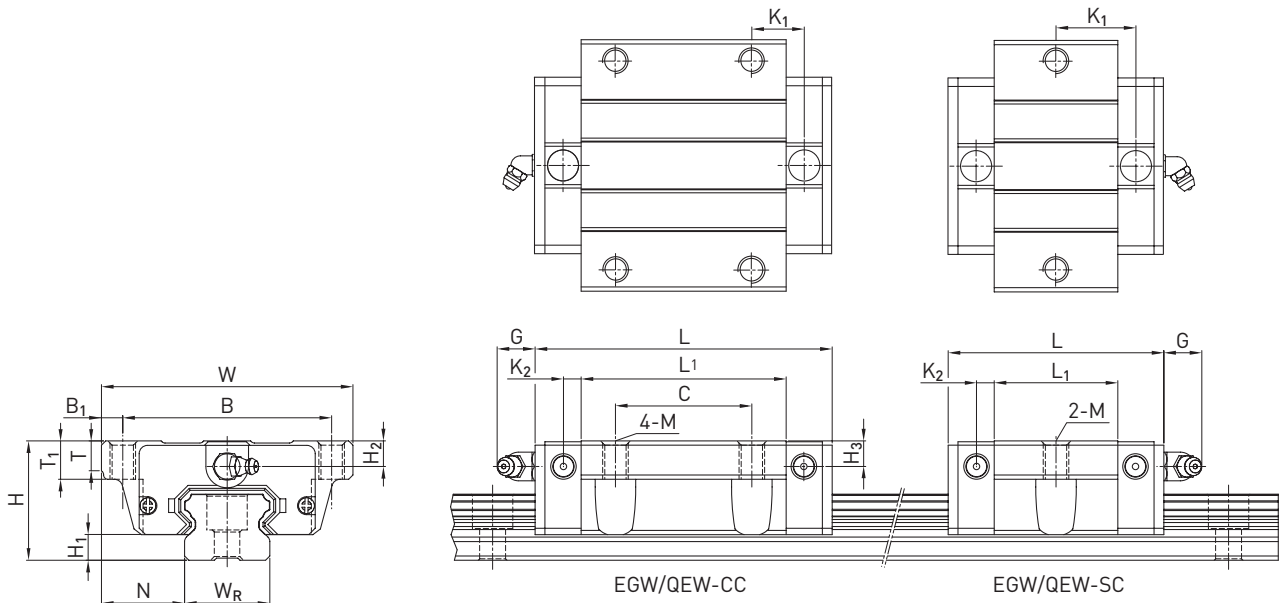

Table 3.27 Dimensions of the block

Series/ size	Installation dimensions [mm]			Dimensions of the block [mm]														Load ratings [N]		Weight [kg]
	H	H ₁	N	W	B	B ₁	C	L ₁	L	K ₁	K ₂	G	M	T	T ₁	H ₂	H ₃	C _{dyn}	C ₀	
EGW15SC	24	4.5	18.5	52	41	5.5	—	23.1	40.1	14.80	3.50	5.7	M5	5.0	7	5.5	6.0	5,350	9,400	0.12
EGW15CC							26	39.8	56.8	10.15								7,830	16,190	0.21
QEW15SC	24	4.0	18.5	52	41	5.5	—	23.1	40.1	14.80	3.50	5.7	M5	5.0	—	5.5	6.0	8,560	8,790	0.12
QEW15CC							26	39.8	56.8	10.15								12,530	15,280	0.21
EGW20SC	28	6.0	19.5	59	49	5.0	—	29.0	50.0	18.75	4.15	12.0	M6	7.0	9	6.0	6.0	7,230	12,740	0.19
EGW20CC							32	48.1	69.1	12.30								10,310	21,130	0.32
QEW20SC	28	6.0	19.5	59	49	5.0	—	29.0	50.0	18.75	4.15	12.0	M6	7.0	—	6.0	6.5	11,570	12,180	0.19
QEW20CC							32	48.1	69.1	12.30								16,500	20,210	0.31
EGW25SC	33	7.0	25.0	73	60	6.5	—	35.5	59.1	21.90	4.55	12.0	M8	7.5	10	8.0	8.0	11,400	19,500	0.35
EGW25CC							35	59.0	82.6	16.15								16,270	32,400	0.59
QEW25SC	33	6.2	25.0	73	60	6.5	—	35.5	60.1	21.90	5.00	12.0	M8	7.5	—	8.0	8.0	18,240	18,900	0.34
QEW25CC							35	59.0	83.6	16.15								26,030	31,490	0.58
EGW30SC	42	10.0	31.0	90	72	9.0	—	41.5	69.5	26.75	6.00	12.0	M10	7.0	10	8.0	9.0	16,420	28,100	0.62
EGW30CC							40	70.1	98.1	21.05								23,700	47,460	1.04
QEW30SC	42	10.0	31.0	90	72	9.0	—	41.5	67.5	25.75	6.00	12.0	M10	7.0	—	8.0	9.0	26,270	27,820	0.61
QEW30CC							40	70.1	96.1	20.05								37,920	46,630	1.03
EGW35SC	48	11.0	33.0	100	82	9.0	—	45.0	75.0	28.50	7.00	12.0	M10	10.0	13	8.5	8.5	22,660	37,380	0.91
EGW35CC							50	78.0	108.0	20.00								33,350	64,840	1.40
QEW35SC	48	11.0	33.0	100	82	9.0	—	51.0	76.0	30.30	6.25	12.0	M10	10.0	13	8.5	8.5	36,390	36,430	0.77
QEW35CC							50	83.0	108.0	21.30								51,180	59,280	1.19

For dimensions of rail, see Page 54, for standard and optional lubrication adapter, see Page 128.

Linear guideways

EG and QE series

3.2.10 Dimensions of the EG rail

The EG rails are used for both the EG and QE blocks.

3.2.10.1 Dimensions of EGR_R

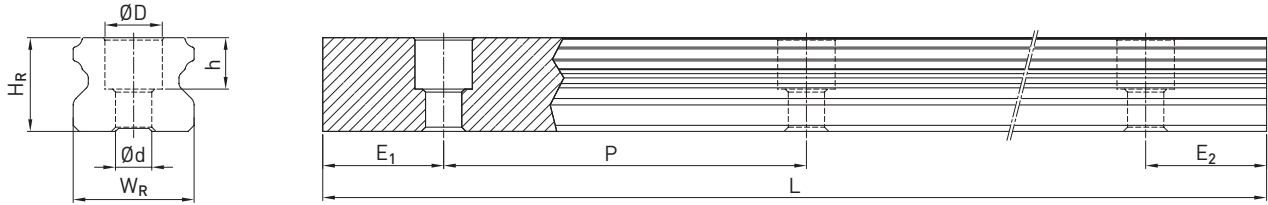

Table 3.28 Dimensions of rail EGR_R

Series/ size	Assembly screw for rail [mm]	Dimensions of rail [mm]						Max. length [mm]	Max. length $E_1 = E_2$ [mm]	Min. length [mm]	$E_{1/2}$ min [mm]	$E_{1/2}$ max [mm]	Weight [kg/m]
		W_R	H_R	D	h	d	P						
EGR15R	M3 × 16	15	12.5	6.0	4.5	3.5	60	4,000	3,900	132	6	54	1.25
EGR20R	M5 × 20	20	15.5	9.5	8.5	6.0	60	4,000	3,900	134	7	53	2.08
EGR25R	M6 × 25	23	18.0	11.0	9.0	7.0	60	4,000	3,900	136	8	52	2.67
EGR30R	M6 × 30	28	23.0	11.0	9.0	7.0	80	4,000	3,920	178	9	71	4.35
EGR35R	M8 × 35	34	27.5	14.0	12.0	9.0	80	4,000	3,920	178	9	71	6.14

3.2.10.2 Dimensions of EGR_U (large mounting holes)

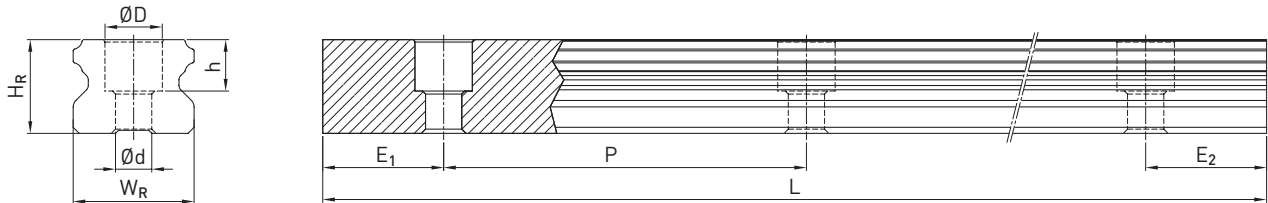

Table 3.29 Dimensions of rail EGR_U

Series/ size	Assembly screw for rail [mm]	Dimensions of rail [mm]						Max. length [mm]	Max. length $E_1 = E_2$ [mm]	Min. length [mm]	$E_{1/2}$ min [mm]	$E_{1/2}$ max [mm]	Weight [kg/m]
		W_R	H_R	D	h	d	P						
EGR15U	M4 × 16	15	12.5	7.5	5.3	4.5	60	4,000	3,900	132	6	54	1.23
EGR30U	M8 × 30	28	23.0	14.0	12.0	9.0	80	4,000	3,920	178	9	71	4.23

Note:

1. The tolerance for E is +0.5 to -1 mm for standard rails and 0 to -0.3 mm for joints.
2. If the $E_{1/2}$ dimensions are not indicated, the maximum possible number of mounting holes will be determined under consideration of $E_{1/2}$ min.
3. The rails are shortened to the required length. If the $E_{1/2}$ dimensions are not indicated, these will be carried out symmetrically.

3.2.10.3 Dimensions of EGR_T (rail mounting from below)

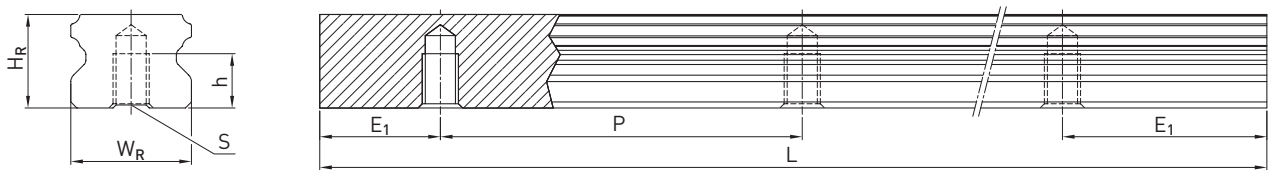

Table 3.30 Dimensions of rail EGR_T

Series/ size	Dimensions of rail [mm]					Max. length [mm]	Max. length $E_1 = E_2$ [mm]	Min. length [mm]	$E_{1/2}$ min [mm]	$E_{1/2}$ max [mm]	Weight [kg/m]
	W_R	H_R	S	h	P						
EGR15T	15	12.5	M5	7	60	4,000	3,900	132	6	54	1.26
EGR20T	20	15.5	M6	9	60	4,000	3,900	134	7	53	2.15
EGR25T	23	18.0	M6	10	60	4,000	3,900	136	8	52	2.79
EGR30T	28	23.0	M8	14	80	4,000	3,920	178	9	71	4.42
EGR35T	34	27.5	M8	17	80	4,000	3,920	178	9	71	6.34

Note:

1. The tolerance for E is +0.5 to -1 mm for standard rails and 0 to -0.3 mm for joints.
2. If the $E_{1/2}$ dimensions are not indicated, the maximum possible number of mounting holes will be determined under consideration of $E_{1/2}$ min.
3. The rails are shortened to the required length. If the $E_{1/2}$ dimensions are not indicated, these will be carried out symmetrically.

3.2.10.4 Calculating the length of rails

HIWIN offers rails in customised lengths. To prevent the risk of the end of the rail becoming unstable, the value E must not exceed half of the distance between the mounting holes (P). At the same time, the value $E_{1/2}$ should be between $E_{1/2}$ min and $E_{1/2}$ max so that the mounting hole does not rupture.

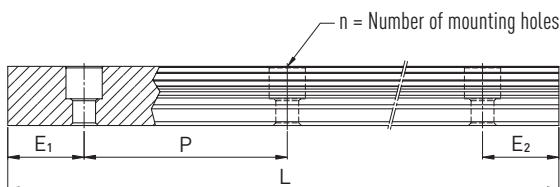

F 3.5

$$L = (n - 1) \times P + E_1 + E_2$$

- L Total length of the rail [mm]
- n Number of mounting holes
- P Distance between two mounting holes [mm]
- $E_{1/2}$ Distance from the middle of the last mounting hole to the end of the rail [mm]

3.2.10.5 Tightening torques for mounting bolts

Insufficient tightening of the mounting bolts strongly compromises the precision of the linear guideway; the following tightening torques are therefore recommended for the relevant screw sizes.

Table 3.31 Tightening torques of the mounting bolts according to ISO 4762-12.9

Series/size	Screw size	Torque [Nm]	Series/size	Screw size	Torque [Nm]
EG/QE_15	M3 × 16	2	EG/QE_30	M6 × 30	14
EG/QE_15U	M4 × 16	4	EG/QE_30U	M8 × 30	31
EG/QE_20	M5 × 20	9	EG/QE_35	M8 × 35	31
EG/QE_25	M6 × 25	14			

Linear guideways

EG and QE series

3.2.10.6 Cover caps for mounting holes of rails

The cover caps are used to keep the mounting holes free of chips and dirt. The standard plastic caps are provided with each rail. Optional cover caps must be ordered separately.

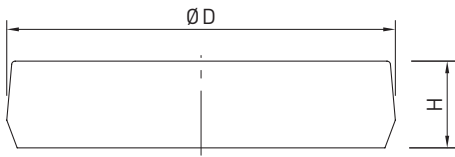

Table 3.32 Cover caps for mounting holes of rails

Rail	Screw	Article number			Ø D [mm]	Height H [mm]
		Plastic (200 pcs.)	Brass	Steel		
EGR15R	M3	5-002217	5-001340	—	6.0	1.2
EGR20R	M5	5-002220	5-001350	5-001352	9.5	2.5
EGR25R	M6	5-002221	5-001355	5-001357	11.0	2.8
EGR30R	M6	5-002221	5-001355	5-001357	11.0	2.8
EGR35R	M8	5-002222	5-001360	5-001362	14.0	3.5
EGR15U	M4	5-002218	5-001344	—	7.5	1.2
EGR30U	M8	5-002222	5-001360	5-001362	14.0	3.5

3.2.11 Sealing systems

Various sealing systems are available for HIWIN blocks. You will find an overview on [Page 22](#). The table below shows the total length of the blocks with the different sealing systems. Sealing systems suitable for these sizes are available.

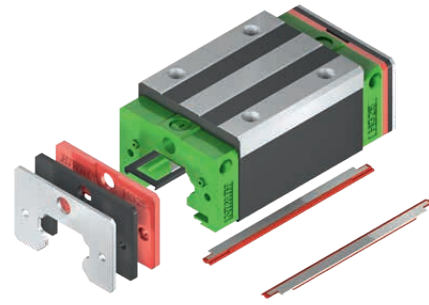

Table 3.33 Total length of blocks with different sealing systems

Series/ size	Total length L			
	SS	DD	ZZ	KK
EG_15S	40.1	44.1	41.7	45.7
QE_15S	40.1	44.1	42.1	46.1
EG_15C	56.8	60.8	58.4	62.4
QE_15C	56.8	60.8	58.8	62.8
EG_20S	50.0	54.0	51.6	55.6
QE_20S	50.0	54.0	52.0	56.0
EG_20C	69.1	73.1	70.7	74.7
QE_20C	69.1	73.1	71.1	75.1
EG_25S	59.1	63.1	61.1	65.1
QE_25S	60.1	65.1	62.1	67.1
EG_25C	82.6	86.6	84.6	88.6
QE_25C	83.6	88.6	85.6	90.6
EG_30S	69.5	73.5	71.5	75.5
QE_30S	67.5	72.5	69.5	74.5
EG_30C	98.1	102.1	100.1	104.1
QE_30C	96.1	101.1	98.1	103.1
EG_35S	75.0	79.0	78.0	82.0
QE_35S	76.0	80.0	79.0	83.0
EG_35C	108.0	112.0	111.0	115.0
QE_35C	108.0	112.0	111.0	115.0

Unit: mm

3.2.11.1 Designation of sealing sets

The sealing sets are always supplied along with the assembly material and include the parts needed in addition to the standard seal.

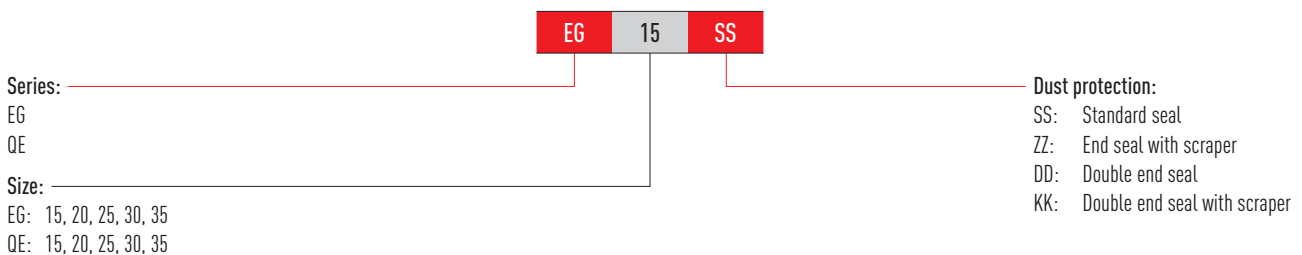

Linear guideways

EG and QE series

3.2.12 Friction

The table shows the maximum frictional resistance of the individual end seal. Depending on sealing setup (SS, ZZ, DD, KK), the value may have to be multiplied. The values indicated apply to blocks on uncoated rails. Higher friction forces occur on coated rails.

Table 3.34 Frictional resistance of single-lipped seals

Series/size	Friction force [N]	Series/size	Friction force [N]
EG_15	1.0	QE_15	1.1
EG_20	1.0	QE_20	1.4
EG_25	1.0	QE_25	1.7
EG_30	1.5	QE_30	2.1
EG_35	2.0	QE_35	2.3

3.2.13 Lubrication unit E2

You will find more information about the lubrication unit in the general information in the lubrication unit E2 Section „2.6.3 Oil lubrication unit E2“ on Page 15.

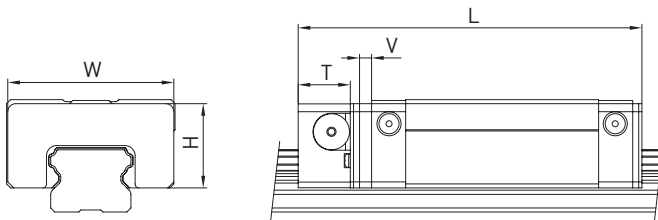

Table 3.35 Dimensions of block with lubrication unit E2

Model	Dimensions of the block [mm]								Oil quantity [cm ³]	Mileage ²⁾ [km]
	W	H	T	V	L _{SS} ¹⁾	L _{ZZ} ¹⁾	L _{DD} ¹⁾	L _{KK} ¹⁾		
EG_15S	33.3	18.7	11.5	3.0	54.6	56.2	58.6	60.2	1.7	2,000
EG_15C	33.3	18.7	11.5	3.0	71.3	72.9	75.3	76.9	1.7	2,000
EG_20S	41.3	20.9	13.0	3.0	66.0	67.6	70.0	71.6	2.9	3,000
EG_20C	41.3	20.9	13.0	3.0	85.1	86.7	89.1	90.7	2.9	3,000
EG_25S	47.3	24.9	13.0	3.0	75.1	77.1	79.1	81.1	4.8	5,000
EG_25C	47.3	24.9	13.0	3.0	98.6	100.6	102.6	104.6	4.8	5,000
EG_30S	59.3	31.0	13.0	3.0	85.5	87.5	89.5	91.5	8.9	9,000
EG_30C	59.3	31.0	13.0	3.0	114.1	116.1	118.1	120.1	8.9	9,000

¹⁾ Total length depending on selected dust protection. SS = Standard dust protection

²⁾ Mileage at which the oil tank level should be checked at the very latest

3.2.14 Tolerances depending on accuracy class

The EG and QE series are available in five accuracy classes depending on parallelism between block and rail, height accuracy H and accuracy of width N. The choice of accuracy class is determined by the machine requirements.

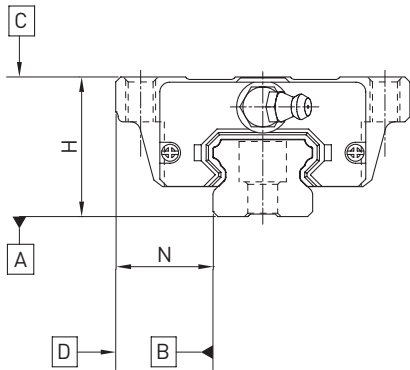

3.2.14.1 Parallelism

Parallelism of stop surfaces D and B of block and rail and parallelism of top of block C to mounting surface A of rail. Ideal linear guideway installation is required, as is a measurement in the centre of the block.

Table 3.36 Tolerance of parallelism between block and rail

Rail length [mm]	Accuracy class				
	C	H	P	SP	UP
- 100	12	7	3	2	2
100 - 200	14	9	4	2	2
200 - 300	15	10	5	3	2
300 - 500	17	12	6	3	2
500 - 700	20	13	7	4	2
700 - 900	22	15	8	5	3
900 - 1100	24	16	9	6	3
1100 - 1500	26	18	11	7	4
1500 - 1900	28	20	13	8	4
1900 - 2500	31	22	15	10	5
2500 - 3100	33	25	18	11	6
3100 - 3600	36	27	20	14	7
3600 - 4000	37	28	21	15	7

Unit: μm

Linear guideways

EG and QE series

3.2.14.2 Accuracy – height and width

Height tolerance of H

Permissible absolute dimension variance of height H, measured between centre of screw-on surface C and underside of rail A, with block in any position on the rail.

Height variance of H

Permissible variance of height H between several blocks on a rail, measured in the same rail position.

Width tolerance of N

Permissible absolute dimension variance of width N, measured between centre of screw-on surfaces D and B, with block in any position on the rail.

Width variance of N

Permissible variance of width N between several blocks on a rail, measured in the same rail position.

Series/size	Accuracy class	Height tolerance of H	Width tolerance of N	Height variance of H	Width variance of N
EG_15, 20 QE_15, 20	C (Normal)	± 0.1	± 0.1	0.02	0.02
	H (High)	± 0.03	± 0.03	0.01	0.01
	P (Precision)	0/- 0.03 ¹⁾ ± 0.015 ²⁾	0/- 0.03 ¹⁾ ± 0.015 ²⁾	0.006	0.006
	SP (Super precision)	0/- 0.015	0/- 0.015	0.004	0.004
	UP (Ultra precision)	0/- 0.008	0/- 0.008	0.003	0.003
EG_25, 30, 35 QE_25, 30, 35	C (Normal)	± 0.1	± 0.1	0.02	0.03
	H (High)	± 0.04	± 0.04	0.015	0.015
	P (Precision)	0/- 0.04 ¹⁾ ± 0.02 ²⁾	0/- 0.04 ¹⁾ ± 0.02 ²⁾	0.007	0.007
	SP (Super precision)	0/- 0.02	0/- 0.02	0.005	0.005
	UP (Ultra precision)	0/- 0.01	0/- 0.01	0.003	0.003

Unit: mm

¹⁾ Fully assembled linear guideway

²⁾ Unmounted linear guideway

3.2.14.3 Permissible mounting surface tolerances

Once the requirements relating to the accuracy of the mounting surfaces are met, the good accuracy, rigidity and lifetime of the EG and QE series linear guideways are achieved.

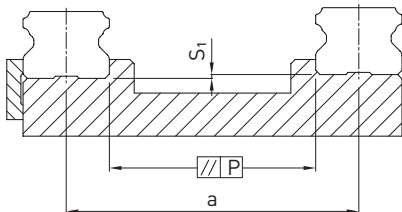

Tolerance for the parallelism of the reference surface (P):

Table 3.38 Maximum tolerance for parallelism (P)

Series/size	Preload class		
	Z0	ZA	ZB
EG/QE_15	25	18	—
EG/QE_20	25	20	18
EG/QE_25	30	22	20
EG/QE_30	40	30	27
EG/QE_35	50	35	30

Unit: μm

Tolerance for the height of the reference surface (S₁):

F 3.6 $S_1 = a \times K$

- S₁ Max. height tolerance [mm]
- a Distance between rails [mm]
- K Coefficient of the height tolerance

Table 3.39 Coefficient of the height tolerance (K)

Series/size	Preload class		
	Z0	ZA	ZB
EG/QE_15	2.6×10^{-4}	1.7×10^{-4}	—
EG/QE_20	2.6×10^{-4}	1.7×10^{-4}	1.0×10^{-4}
EG/QE_25	2.6×10^{-4}	1.7×10^{-4}	1.4×10^{-4}
EG/QE_30	3.4×10^{-4}	2.2×10^{-4}	1.8×10^{-4}
EG/QE_35	4.2×10^{-4}	3.0×10^{-4}	2.4×10^{-4}

3.2.15 Shoulder heights and fillets

Imprecise shoulder heights and fillets of mounting surfaces compromise precision and may lead to conflicts with the block or rail profiles. The following shoulder heights and edge profiles must be observed in order to avoid assembly problems.

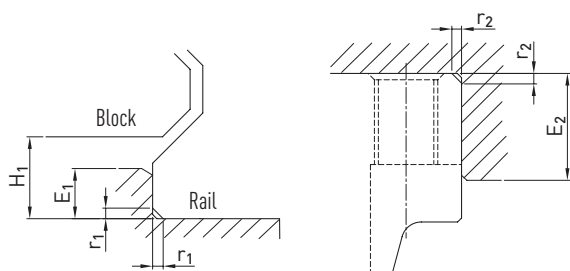

Table 3.40 Shoulder heights and fillets

Series/size	Max. edge radius r ₁	Max. edge radius r ₂	Shoulder height of reference edge of rail E ₁	Shoulder height of reference edge of block E ₂	Clearance under block H ₁
EG/QE_15	0.5	0.5	2.7	5.0	4.5
EG/QE_20	0.5	0.5	5.0	7.0	6.0
EG/QE_25	1.0	1.0	5.0	7.5	7.0
EG/QE_30	1.0	1.0	7.0	7.0	10.0
EG_35	1.0	1.0	7.5	9.5	11.0
QE_35	1.0	1.5	7.5	9.5	11.0

Unit: mm

Linear guideways

CG series

3.3 CG series

3.3.1 Properties of the linear guideways, series CG

The HIWIN linear guideways of the CG series with O-arrangement of the ball tracks guarantee high torque loading capacity, especially in the M_x direction. The modified track geometry ensures high load ratings. The new flexible end seal automatically adjusts itself to the rail contour and ensures a high, permanent dust protection.

To protect the end seal against mechanical damage, the CG series is equipped with a sheet metal scraper in front of the end seal as standard.

Optionally, a cover strip is available – the entry of dust and wear of the sealing lip are thus permanently reduced to a minimum. With the help of a mounting tool the cover strip is installed in a few easy steps.

For optimum lubricant distribution the block has an additional lubrication path which leads the lubricant into the middle of the carrying zone. This ensures long relubrication intervals and a significant advantage especially in short stroke applications.

3.3.2 Design of the CG series

Free of play 4-row recirculation ball bearing guide with best dust protection already in the standard version.

Easy mounting, better protection against entry of dust and against wear of the end seal due to cover strip.

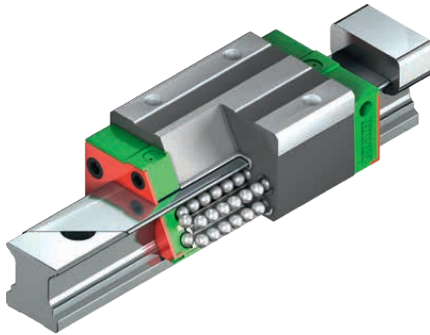

Optimized lubrication concept for long relubrication intervals and short stroke applications.

O-arrangement and optimized geometry of ball bearing guide for high torque loading capacity and high load ratings.

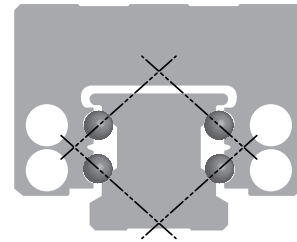
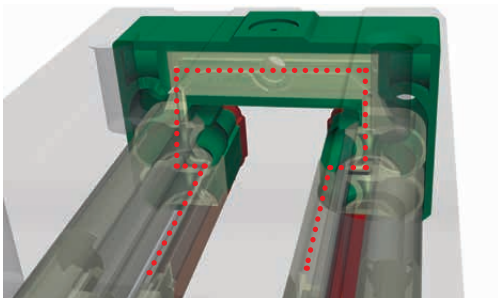

Advantages:

- Free of play
- Interchangeable
- High accuracy
- High torque loading capacity, especially rolling moment M_x
- Optional with cover strip

3.3.3 Order codes for the CG series

For CG linear guideways, a distinction is made between fully assembled and unmounted models. The dimensions of both models are the same. The main difference is that the block and rail in the unmounted models can be freely interchanged. Block and rail can be ordered separately and fitted by the customer. Their accuracy extends to class P.

Order code for linear guideway (fully assembled)

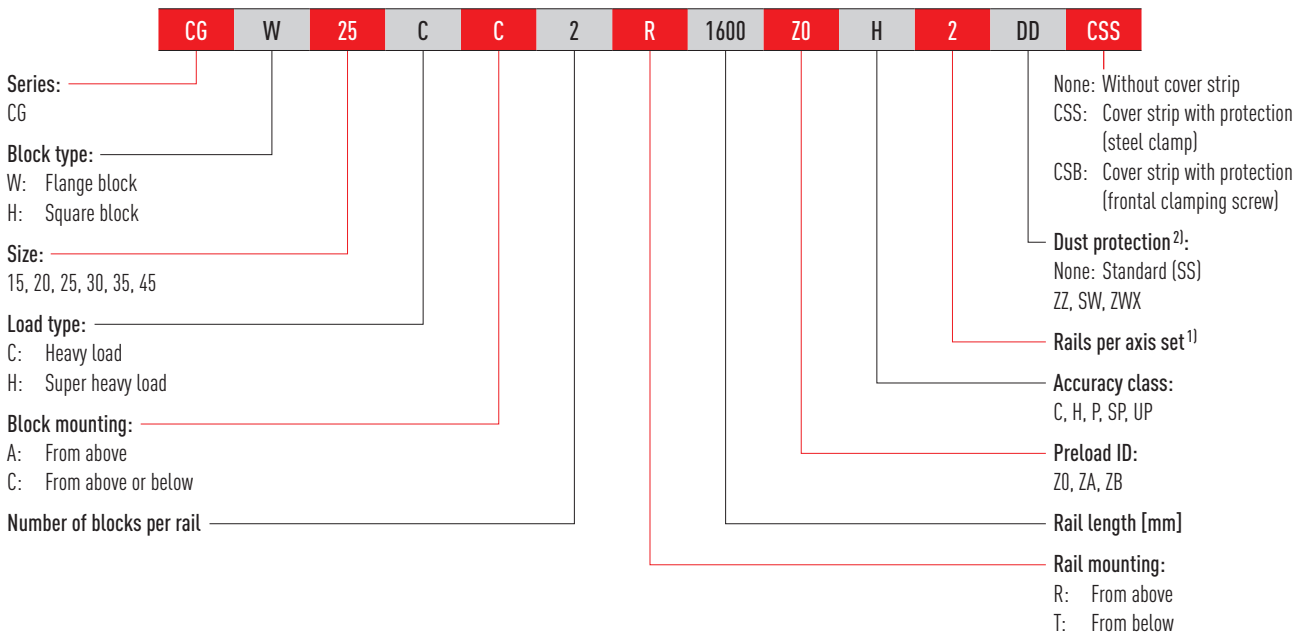

Order code for block (unmounted)

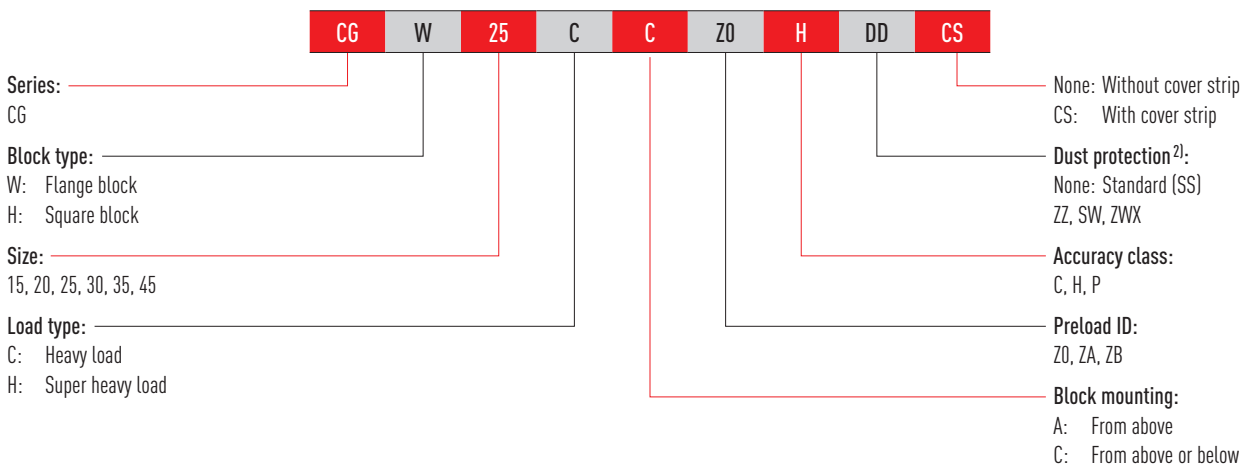

Order code for rail (unmounted)

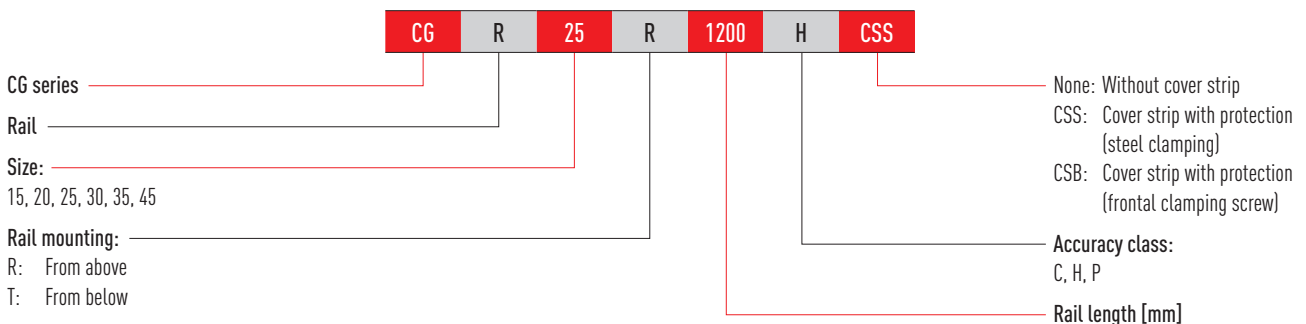

Note:

¹⁾ The figure 2 is also a quantity, i.e. one item of the above-mentioned article consists of a pair of rails. No number is specified for individual rails.

By default multi-part rails are delivered with staggered butt joints.

²⁾ You will find an overview of the individual sealing systems on [Page 22](#)

Linear guideways

CG series

3.3.4 Block types

HIWIN provides square and flange blocks for its linear guideways. Given their low height and larger mounting surface, flange blocks are better suited to large loads.

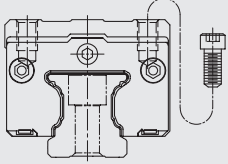
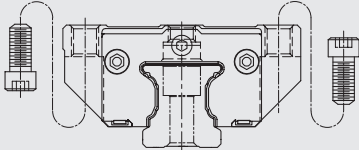
Type	Series/size	Structure	Height [mm]	Typical application
Square type	CGH-CA CGH-HA		28 – 70	<ul style="list-style-type: none"> ○ Woodworking ○ Machining centres ○ NC lathes ○ Grinding machines ○ Precision milling machines ○ High-performance cutting machines
Flange type	CGW-CA CGW-HA		24 – 60	<ul style="list-style-type: none"> ○ Automation technology ○ Transport technology ○ Measuring technology ○ Machines and equipment requiring high positioning accuracy

3.3.5 Rail types

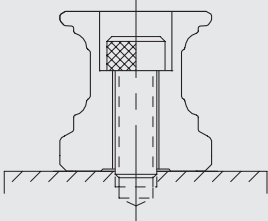
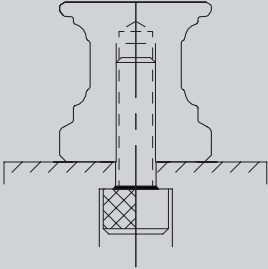
Fastening from above	Fastening from below
	
CGR_R	CGR_T

3.3.6 Preload

Definition

Every rail type can be preloaded based on the size of the balls. The curve shows that the rigidity doubles at higher preload. The CG series offers three standard preload classes for various applications and conditions.

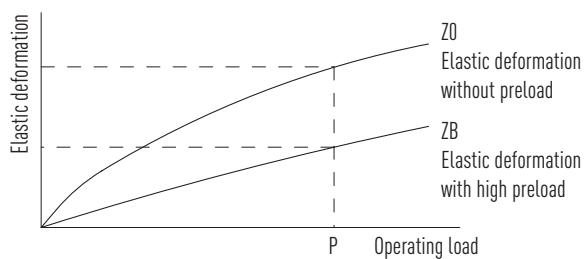

Preload ID

ID	Preload		Application	Sample applications
ZO	Light preload	0 – 0.02 C _{dyn}	Constant load direction, little vibration, lower accuracy needed	<ul style="list-style-type: none"> ○ Transport technology ○ Automatic packaging machines ○ X-Y axis in industrial machines ○ Welding machines
ZA	Medium preload	0.05 – 0.07 C _{dyn}	High accuracy needed	<ul style="list-style-type: none"> ○ Machining centres ○ Z axes for industrial machines ○ Eroding machines ○ NC lathes ○ Precision X-Y tables ○ Measuring technology
ZB	High preload	above 0.1 C _{dyn}	High rigidity needed, vibration and impact	<ul style="list-style-type: none"> ○ Machining centres ○ Grinding machines ○ NC lathes ○ Horizontal and vertical milling machines ○ Z axis of machine tools ○ High-performance cutting machines

3.3.7 Load ratings and torques

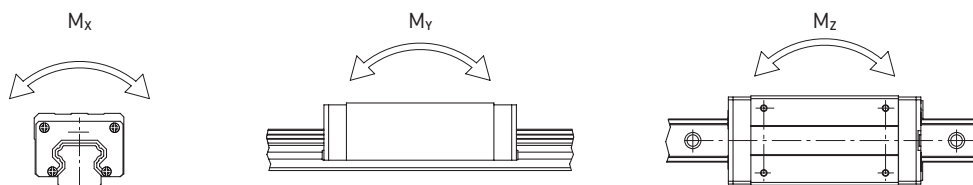

Series/size	Dynamic load rating C _{dyn} [N] ¹⁾	Static load rating C ₀ [N]	Dynamic moment [Nm]			Static moment [Nm]		
			M _x	M _y	M _z	M _{0x}	M _{0y}	M _{0z}
CG_15C	14,700	19,520	143	105	105	190	140	140
CG_20C	23,700	30,510	287	218	218	370	280	280
CG_20H	28,600	39,900	344	344	344	480	480	480
CG_25C	34,960	43,940	477	390	390	600	490	490
CG_25H	40,500	54,080	554	546	546	740	730	730
CG_30C	46,000	55,190	792	583	583	950	700	700
CG_30H	58,590	78,180	1,011	921	921	1,350	1,230	1,230
CG_35C	61,170	79,300	1,334	841	841	1,730	1,090	1,090
CG_35H	77,900	112,340	1,705	1,400	1,400	2,460	2,020	2,020
CG_45C	98,430	112,660	3,037	2,076	2,076	3,560	2,350	2,350
CG_45H	125,580	159,600	2,893	2,549	2,549	5,050	4,450	4,450

¹⁾ Dynamic load rating for travel distance of 50,000 m

Linear guideways

CG series

3.3.8 Rigidity

Rigidity depends on preload. Formula [F 3.7](#) can be used to determine deformation depending on rigidity.

F 3.7

$$\delta = \frac{P}{k}$$

δ Deformation [μm]
 P Operating load [N]
 k Rigidity [N/ μm]

Table 3.45 Radial rigidity for series CG

Load class	Series/ size	Rigidity depending on preload		
		Z0	ZA	ZB
Heavy load	CG_15C	240	290	330
	CG_20C	270	420	480
	CG_25C	340	440	570
	CG_30C	440	550	760
	CG_35C	470	610	800
	CG_45C	550	720	820
Super heavy load	CG_20H	360	470	530
	CG_25H	410	540	620
	CG_30H	490	640	730
	CG_35H	570	730	840
	CG_45H	740	960	1,100

Unit: N/ μm

3.3.9 Dimensions of the CG blocks

3.3.9.1 CGH

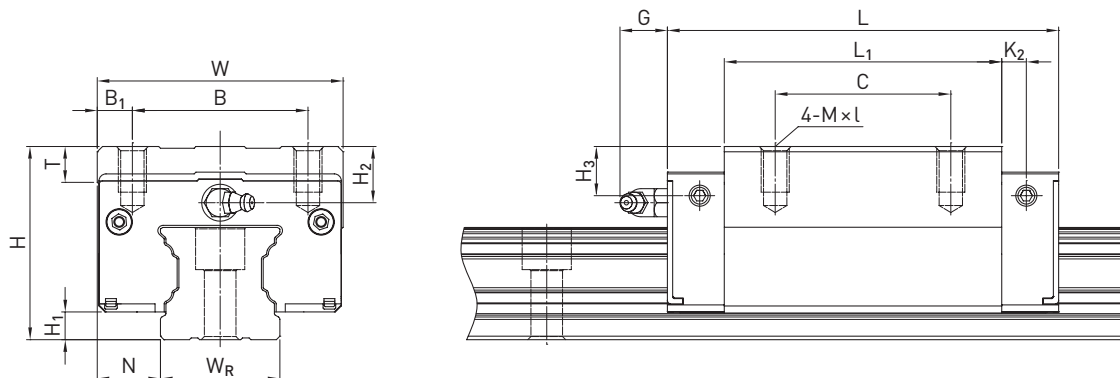

Table 3.46 Dimensions of the block

Series/size	Installation dimensions [mm]			Dimensions of the block [mm]													Load ratings [N]		Weight [kg]
	H	H ₁	N	W	B	B ₁	C	L ₁	L	K ₂	G	M × l	T	H ₂	H ₃	C _{dyn}	C ₀		
CGH15CA	28	4.1	9.5	34	26	4.0	26	39.6	58.2	4.25	6.0	M4 × 6	6.0	7.8	7.8	14,700	19,520	0.15	
CGH20CA	30	4.6	12.0	44	32	6.0	36	52.5	74.9	5.50	6.0	M5 × 6	8.0	3.7	3.5	23,700	30,510	0.25	
CGH20HA							50												68.5
CGH25CA	40	6.1	12.5	48	35	6.5	35	61.0	84.0	5.00	12.0	M6 × 8	8.0	10.0	9.5	34,960	43,940	0.46	
CGH25HA							50												78.4
CGH30CA	45	7.0	16.0	60	40	10.0	40	69.0	97.4	8.70	12.0	M8 × 10	9.5	9.7	10.0	46,000	55,190	0.71	
CGH30HA							60												91.5
CGH35CA	55	7.6	18.0	70	50	10.0	50	79.0	111.4	7.00	12.0	M8 × 13	10.2	16.0	14.0	61,170	79,300	1.24	
CGH35HA							72												103.4
CGH45CA	70	9.7	20.5	86	60	13.0	60	97.2	137.6	8.70	12.9	M10 × 17	16.0	18.5	18.2	98,430	112,660	2.38	
CGH45HA							80												133.6

For dimensions of rail, see [Page 69](#). for standard and optional lubrication adapter, see [Page 128](#).

Linear guideways

CG series

3.3.9.2 CGW

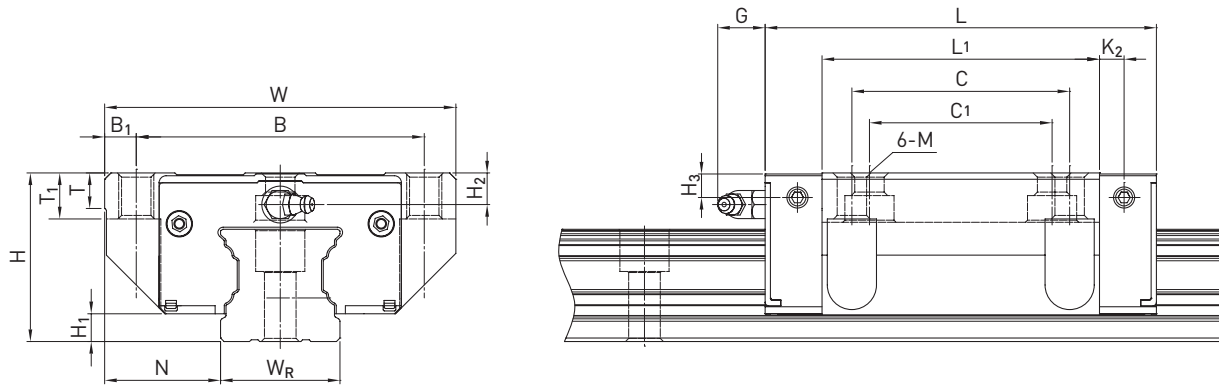

Table 3.47 Dimensions of the block

Series/size	Installation dimensions [mm]			Dimensions of the block [mm]														Load ratings [N]		Weight [kg]
	H	H ₁	N	W	B	B ₁	C	C ₁	L ₁	L	K ₂	G	M	T	T ₁	H ₂	H ₃	C _{dyn}	C ₀	
CGW15CC	24	4.1	16.0	47	38	4.5	30	26	39.6	58.2	4.25	6.0	M5	6.0	6.5	3.8	3.8	14,700	19,520	0.14
CGW20CC	30	4.6	21.5	63	53	5.0	40	35	52.5	74.9	5.50	6.0	M6	6.5	7.7	3.7	3.5	23,700	30,510	0.36
CGW20HC									68.5	90.9								28,600	39,900	0.47
CGW25CC	36	6.1	23.5	70	57	6.5	45	40	61.0	84.0	5.00	12.0	M8	7.0	9.3	6.0	5.5	34,960	43,940	0.53
CGW25HC									78.4	101.4								40,500	54,080	0.68
CGW30CC	42	7.0	31.0	90	72	9.0	52	44	69.0	97.4	8.70	12.0	M10	10.5	12.0	6.7	7.0	46,000	55,190	0.90
CGW30HC									91.5	119.9								58,590	78,180	1.19
CGW35CC	48	7.6	33.0	100	82	9.0	62	52	79.0	111.4	7.00	12.0	M10	10.1	13.1	9.0	7.0	61,170	79,300	1.37
CGW35HC									103.4	135.8								77,900	112,340	1.79
CGW45CC	60	9.7	37.5	120	100	10.0	80	60	97.2	137.6	8.70	12.9	M12	15.1	15.0	8.5	8.1	98,430	112,660	2.45
CGW45HC									133.6	174.0								125,580	159,600	3.00

For dimensions of rail, see [Page 69](#). for standard and optional lubrication adapter, see [Page 128](#).

3.3.10 Dimensions of the CG rail

3.3.10.1 Dimensions of rail CGR_R

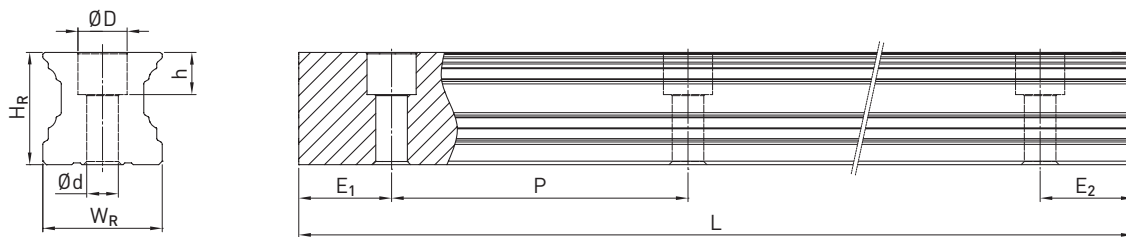

Table 3.48 Dimensions of rail CGR_R

Series/ size	Assembly screw for rail [mm]	Dimensions of rail [mm]						Max. length [mm]	Max. length E ₁ = E ₂ [mm]	Min. length [mm]	E _{1/2} min [mm]	E _{1/2} max [mm]	Weight [kg/m]
		W _R	H _R	D	h	d	P						
CGR15R	M4 × 20	15	16.20	7.5	5.9	4.5	60	4,000	3,900	132	6	54	1.58
CGR20R	M5 × 25	20	20.55	9.5	8.5	6.0	60	4,000	3,900	134	7	53	2.48
CGR25R	M6 × 30	23	24.25	11.0	9.0	7.0	60	4,000	3,900	136	8	52	3.38
CGR30R	M8 × 35	28	28.35	14.0	12.4	9.0	80	4,000	3,920	178	9	71	5.10
CGR35R	M8 × 40	34	31.85	14.0	12.0	9.0	80	4,000	3,920	178	9	71	7.14
CGR45R	M12 × 50	45	39.85	20.0	17.0	14.0	105	4,000	3,885	234	12	93	11.51

3.3.10.2 Dimensions of rail CGR_T

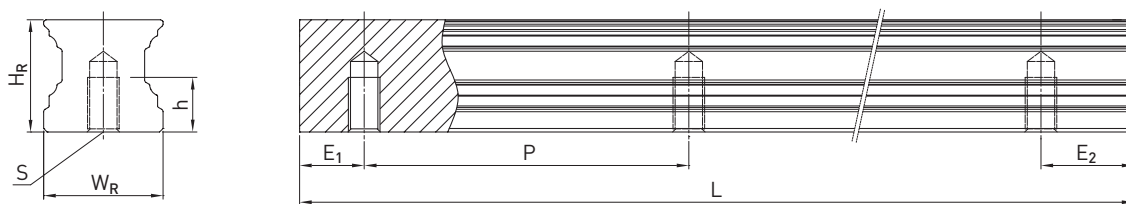

Table 3.49 Dimensions of rail CGR_T

Series/ size	Dimensions of rail [mm]					Max. length [mm]	Max. length E ₁ = E ₂ [mm]	Min. length [mm]	E _{1/2} min [mm]	E _{1/2} max [mm]	Weight [kg/m]
	W _R	H _R	S	h	P						
CGR15T	15	16.20	M5	8	60	4,000	3,900	132	6	54	1.58
CGR20T	20	20.55	M6	10	60	4,000	3,900	134	7	53	2.48
CGR25T	23	24.25	M6	12	60	4,000	3,900	136	8	52	3.38
CGR30T	28	28.35	M8	15	80	4,000	3,920	178	9	71	5.10
CGR35T	34	31.85	M8	17	80	4,000	3,920	178	9	71	7.14
CGR45T	45	39.85	M12	24	105	4,000	3,885	234	12	93	11.51

Note:

1. The tolerance for E is +0.5 to -1 mm for standard rails and 0 to -0.3 mm for joints.
2. If the E_{1/2} dimensions are not indicated, the maximum possible number of mounting holes will be determined under consideration of E_{1/2} min.
3. The rails are shortened to the required length. If the E_{1/2} dimensions are not indicated, these will be carried out symmetrically.

Linear guideways

CG series

3.3.10.3 Calculating the length of rails

HIWIN offers rails in customized lengths. To prevent the risk of the end of the rail becoming unstable, the value E must not exceed half of the distance between the mounting holes (P). At the same time, the value $E_{1/2}$ should be between $E_{1/2}$ min and $E_{1/2}$ max so that the mounting hole does not rupture.

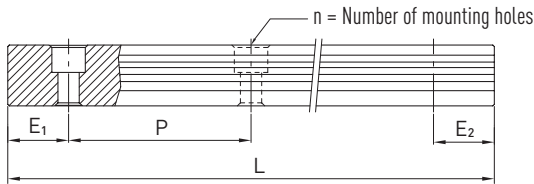

F 3.8

$$L = (n - 1) \times P + E_1 + E_2$$

- L Total length of the rail [mm]
- n Number of mounting holes
- P Distance between two mounting holes [mm]
- $E_{1/2}$ Distance from the middle of the last mounting hole to the end of the rail [mm]

3.3.10.4 Tightening torques for mounting bolts

Insufficient tightening of the mounting bolts strongly compromises the precision of the linear guideway; the following tightening torques are therefore recommended for the relevant screw sizes.

Table 3.50 Tightening torques of the mounting bolts according to ISO 4762-12.9

Series/size	Screw size	Torque [Nm]	Series/size	Screw size	Torque [Nm]
CG_15	M4 × 20	4	CG_30	M10	70
CG_20	M5 × 25	9	CG_35	M8 × 40	31
CG_25	M6 × 30	14	CG_35	M10	70
CG_30	M8 × 35	31	CG_45	M12 × 50	120

3.3.10.5 Cover caps for mounting holes of rails

The cover caps are used to keep the mounting holes free of chips and dirt. The standard plastic caps are provided with each rail. Optional cover caps must be ordered separately.



Table 3.51 Cover caps for mounting holes of rails

Rail	Screw	Article number			Ø D [mm]	Height H [mm]
		Plastic (200 pcs.)	Brass	Steel		
CGR15R	M4	5-002218	5-001344	—	7.5	1.2
CGR20R	M5	5-002220	5-001350	5-001352	9.5	2.5
CGR25R	M6	5-002221	5-001355	5-001357	11.0	2.8
CGR30R	M8	5-002222	5-001360	5-001362	14.0	3.5
CGR35R	M8	5-002222	5-001360	5-001362	14.0	3.5
CGR45R	M12	5-002223	5-001324	5-001327	20.0	4.0

3.3.10.6 Cover strip protection

The optional cover strip is delivered with a steel clamp for securing the strip. Alternatively, the cover strip can also be secured with a frontal clamping screw.



Fig. 3.1 Cover strip protection: steel clamp

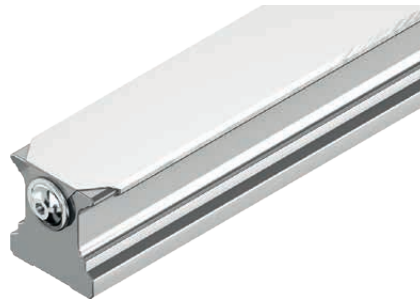

Fig. 3.2 Cover strip protection: frontal clamping screw

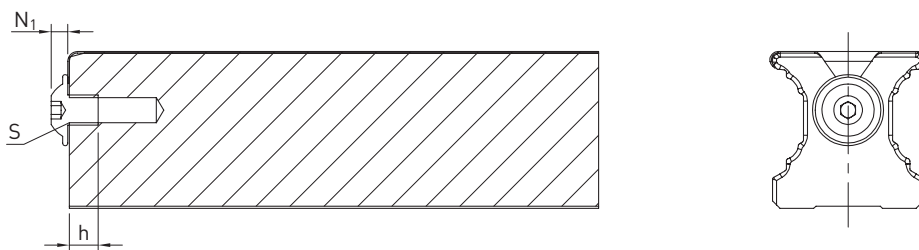

Table 3.52 Dimensions of frontal clamping screw protection

Series/size	S [mm]	h [mm]	N ₁ [mm]
CG_15	M3	5	1.65
CG_20	M4	5	2.20
CG_25	M4	5	2.20
CG_30	M4	5	2.20
CG_35	M6	9	3.30
CG_45	M6	9	3.30

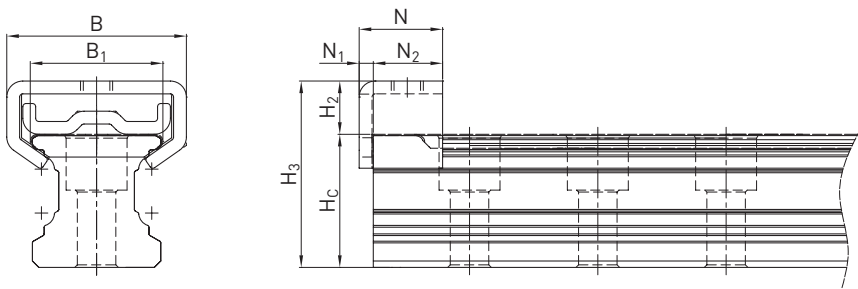

Table 3.53 Dimensions of steel clamp protection

Series/size	H ₃ [mm]	H _c [mm]	H ₂ [mm]	N	N ₁ [mm]	N ₂ [mm]	B [mm]	B ₁ [mm]
CG_15	20.09	16.70	3.9	15	2.2	12.8	21.0	15.8
CG_20	29.05	20.75	8.3	13	2.2	10.8	28.0	20.7
CG_25	34.42	24.45	10.0	15	2.2	12.8	30.6	23.9
CG_30	37.80	28.55	9.3	12	2.2	9.8	34.0	28.9
CG_35	43.20	30.40	13.0	18	2.2	15.8	35.4	34.8
CG_45	52.66	39.85	13.7	18	2.2	15.8	53.6	45.6

Linear guideways

CG series

3.3.11 Sealing systems

Various sealing systems are available for HIWIN blocks. You will find an overview on [Page 22](#). The table below shows the total length of the blocks with the different sealing systems. Sealing systems suitable for these sizes are available.

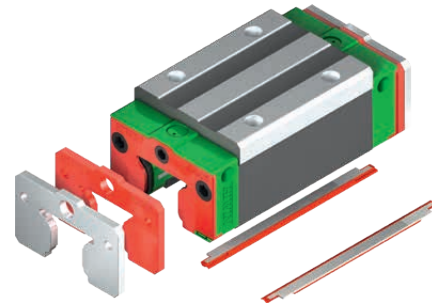

Table 3.54 Total length of blocks with different sealing systems

Series/ size	Total length L			
	SS	ZZ	SW	ZWX
CG15C	58.2	61.2	63.2	66.2
CG20C	74.9	77.9	79.9	82.9
CG20H	90.9	93.9	95.9	98.9
CG25C	84.0	90.0	89.0	95.0
CG25H	101.4	107.4	106.4	112.4
CG30C	97.4	103.4	102.8	108.8
CG30H	119.9	125.9	125.3	131.3
CG35C	111.4	117.4	116.8	122.8
CG35H	135.8	141.8	141.2	147.2
CG45C	137.6	143.6	143.0	149.0
CG45H	172.3	178.3	177.7	183.7

Unit: mm

3.3.12 Tolerances depending on accuracy class

The CG series is available in five accuracy classes depending on parallelism between block and rail, height accuracy H and accuracy of width N. The choice of accuracy class is determined by the machine requirements.

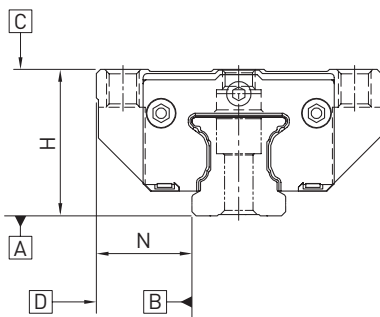

3.3.12.1 Parallelism

Parallelism of stop surfaces D and B of block and rail and parallelism of top of block C to mounting surface A of rail. Ideal linear guideway installation is required, as is a measurement in the centre of the block.

Table 3.55 Tolerance of parallelism between block and rail

Rail length [mm]	Accuracy class				
	C	H	P	SP	UP
- 100	12	7	3	2	2
100 - 200	14	9	4	2	2
200 - 300	15	10	5	3	2
300 - 500	17	12	6	3	2
500 - 700	20	13	7	4	2
700 - 900	22	15	8	5	3
900 - 1100	24	16	9	6	3
1100 - 1500	26	18	11	7	4
1500 - 1900	28	20	13	8	4
1900 - 2500	31	22	15	10	5
2500 - 3100	33	25	18	11	6
3100 - 3600	36	27	20	14	7
3600 - 4000	37	28	21	15	7

Unit: μm

Linear guideways

CG series

3.3.12.2 Accuracy – height and width

Height tolerance of H

Permissible absolute dimension variance of height H, measured between centre of screw-on surface C and underside of rail A, with block in any position on the rail.

Height variance of H

Permissible variance of height H between several blocks on a rail, measured in the same rail position.

Width tolerance of N

Permissible absolute dimension variance of width N, measured between centre of screw-on surfaces D and B, with block in any position on the rail.

Width variance of N

Permissible variance of width N between several blocks on a rail, measured in the same rail position.

Table 3.56 Height and width tolerances

Series/size	Accuracy class	Height tolerance of H (T _H)	Width tolerance of N	Height variance of H	Width variance of N
CG_15, 20	C (Normal)	± 0.1	± 0.1	0.02	0.02
	H (High)	± 0.03	± 0.03	0.01	0.01
	P (Precision)	0/− 0.03 ¹⁾ ± 0.015 ²⁾	0/− 0.03 ¹⁾ ± 0.015 ²⁾	0.006	0.006
	SP (Super precision)	0/− 0.015	0/− 0.015	0.004	0.004
	UP (Ultra precision)	0/− 0.008	0/− 0.008	0.003	0.003
CG_25, 30, 35	C (Normal)	± 0.1	± 0.1	0.02	0.03
	H (High)	± 0.04	± 0.04	0.015	0.015
	P (Precision)	0/− 0.04 ¹⁾ ± 0.02 ²⁾	0/− 0.04 ¹⁾ ± 0.02 ²⁾	0.007	0.007
	SP (Super precision)	0/− 0.02	0/− 0.02	0.005	0.005
	UP (Ultra precision)	0/− 0.01	0/− 0.01	0.003	0.003
CG_45	C (Normal)	± 0.1	± 0.1	0.03	0.03
	H (High)	± 0.05	± 0.05	0.015	0.02
	P (Precision)	0/− 0.05 ¹⁾ ± 0.025 ²⁾	0/− 0.05 ¹⁾ ± 0.025 ²⁾	0.007	0.01
	SP (Super precision)	0/− 0.03	0/− 0.03	0.005	0.007
	UP (Ultra precision)	0/− 0.02	0/− 0.02	0.003	0.005

Unit: mm

¹⁾ Fully assembled linear guideway

²⁾ Unmounted linear guideway

3.3.12.3 Permissible mounting surface tolerances

Once the requirements relating to the accuracy of the mounting surfaces are met, the good accuracy, rigidity and lifetime of the CG series linear guideways are achieved.

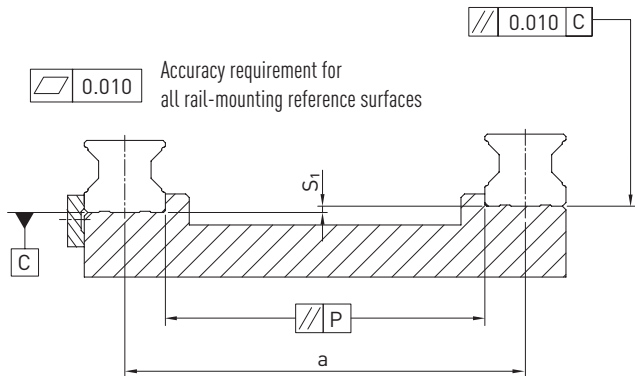

Tolerance for the parallelism of the reference surface (P):

Table 3.57 Maximum tolerance for parallelism (P)

Series/size	Preload class		
	Z0	ZA	ZB
CG_15	9	5	4
CG_20	11	7	5
CG_25	12	8	6
CG_30	14	9	7
CG_35	15	11	8
CG_45	19	12	10

Unit: μm

Tolerance for the height of the reference surface (S_1)

F 3.9 $S_1 = a \times K - T_H$

- S_1 Max. height tolerance [mm]
- a Distance between rails [mm]
- K Coefficient of the height tolerance
- T_H Tolerance of height H acc. to [Table 3.56](#)

Table 3.58 Coefficient of height tolerance (K)

Series/size	Preload class		
	Z0	ZA	ZB
CG_15 - CG_45	2.8×10^{-4}	1.7×10^{-4}	1.2×10^{-4}

Note: If $S_1 < 0$, select another tolerance class!

Linear guideways

CG series

Height tolerance of the block mounting surface:

- The height tolerance of the reference surface in the parallel use of two or more blocks (S_2)

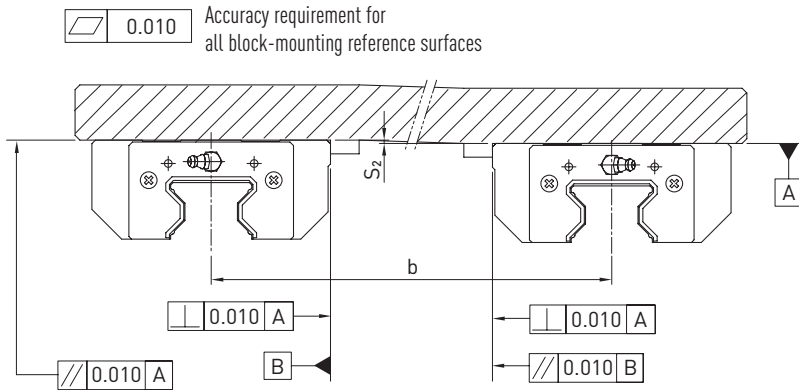

F 3.10 $S_2 = b \times K$

- S_2 Max. height tolerance [mm]
- b Distance between blocks [mm]
- K Coefficient of the height tolerance

- The height tolerance of the reference surface in the parallel use of two or more blocks (S_3)

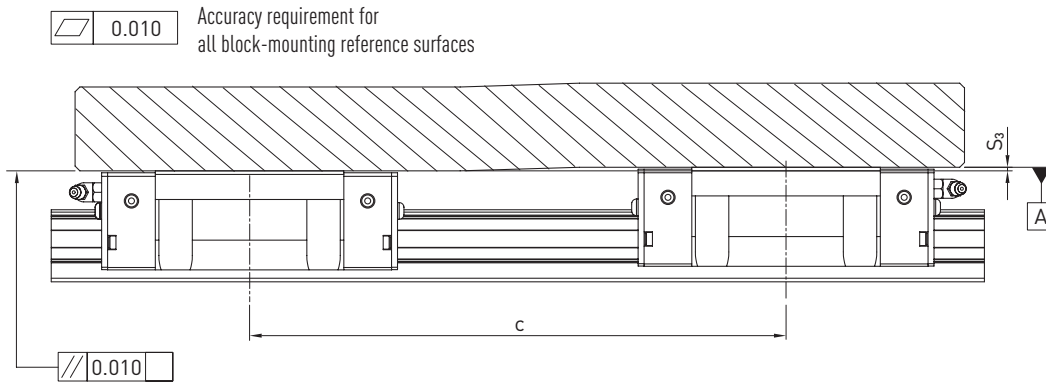

F 3.11 $S_3 = c \times K$

- S_3 Max. height tolerance [mm]
- c Distance between blocks [mm]
- K Coefficient of the height tolerance

Table 3.59 Coefficient of height tolerance (K)		
Series/size	Load type	
	CG_C	CG_H
CG_15 – CG_45	4.2×10^{-5}	3.0×10^{-5}

3.3.13 Shoulder heights and fillets

Imprecise shoulder heights and fillets of mounting surfaces compromise precision and may lead to conflicts with the block or rail profiles. The following shoulder heights and edge profiles must be observed in order to avoid assembly problems.

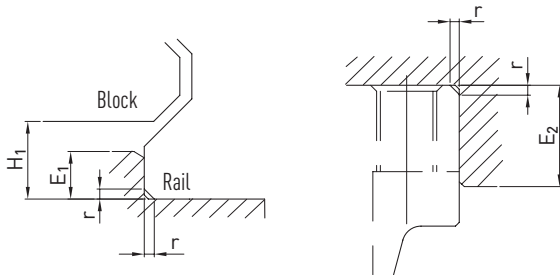

Table 3.60 Shoulder heights and fillets

Series/size	Max. edge radius r	Shoulder height of reference edge of rail E_1	Shoulder height of reference edge of block E_2	Clearance under block H_1
CG_15	0.5	3.0	4.0	4.3
CG_20	0.5	3.5	5.0	4.6
CG_25	1.0	5.0	5.0	6.1
CG_30	1.0	5.0	5.0	7.0
CG_35	1.0	6.0	6.0	7.6
CG_45	1.0	8.0	8.0	9.5

Unit: mm

Linear guideways

WE and QW series

3.4 WE and QW series

3.4.1 Properties of the linear guideway, series WE and QW

The HIWIN linear guideways of the WE series are based on proven HIWIN technology. Their large rail width and low installation height permit a compact design and high torque loading capacity.

The models of the QW series with SynchMotion™ technology offer all the advantages of the standard series WE. Controlled movement of the balls at a defined distance also results in improved synchronous performance, higher reliable travel speeds, extended lubrication intervals and less running noise. Since the installation dimensions of the QW blocks are identical to those of the WE blocks, they are also fitted on the WER standard rail and can therefore be interchanged with ease. For more information, refer to [Page 24](#).

3.4.2 Design of the WE/QW series

- 4-row recirculation ball bearing guide
- 45° contact angle
- Ball retainers prevent the balls from falling out when the block is removed
- Low installation height
- Wide linear guideway for high torque loading capacity
- Large mounting surface on block
- SynchMotion™ technology (QW series)

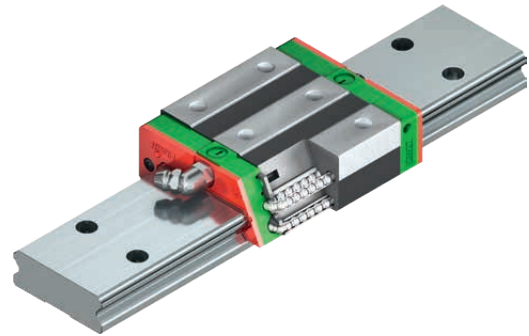
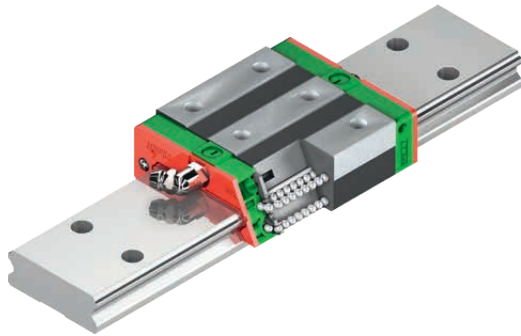

Design of the WE series

Advantages:

- Compact and low-cost design thanks to high torque loading capacity
- High efficiency thanks to low friction losses

Design of the QW series

Additional advantages of QW series:

- Improved synchronous performance
- Optimized for higher travel speeds
- Extended lubrication intervals
- Less running noise
- Higher dynamic load capacities

50% wider than standard series

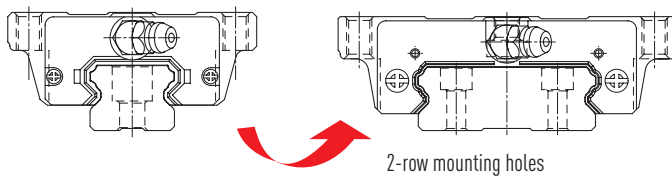

- The block's large mounting surface supports the transfer of higher torques
- The 45° arrangement of ball tracks permits high loading from all directions

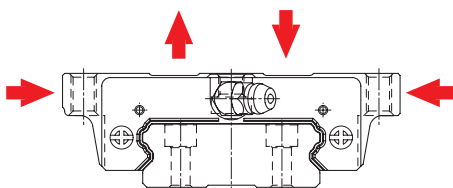

3.4.3 Order codes for the WE/QW series

For WE/QW linear guideways, a distinction is made between fully assembled and unmounted models. The dimensions of both models are the same. The main difference is that the block and rail in the unmounted models can be freely interchanged. Block and rail can therefore be ordered separately and fitted by the customer. Their accuracy extends to class P.

Order code for linear guideway (fully assembled)

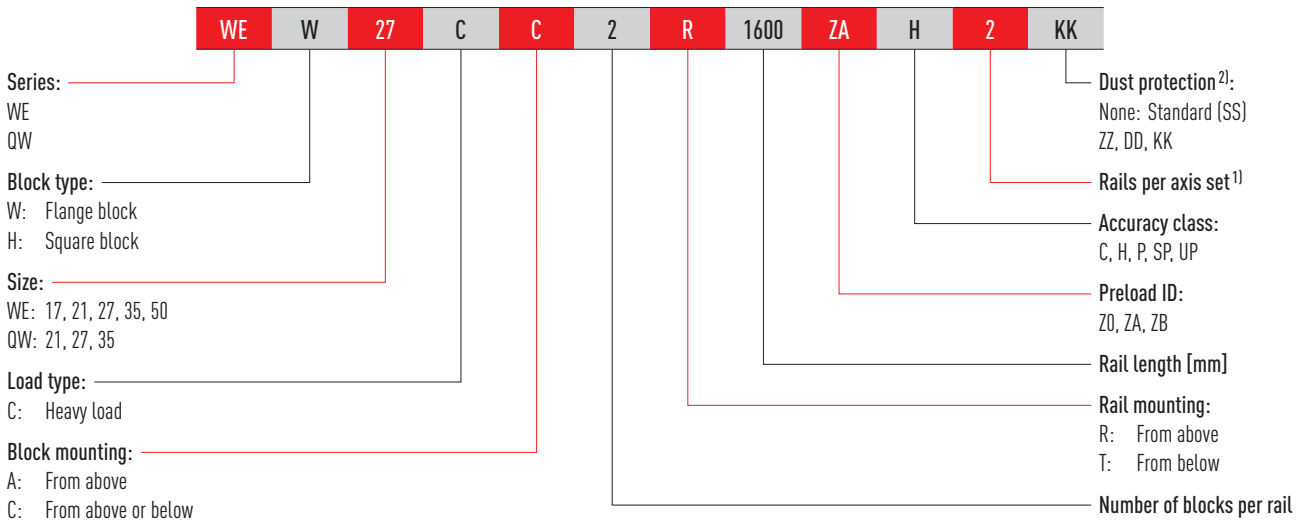

Order code for block (unmounted)

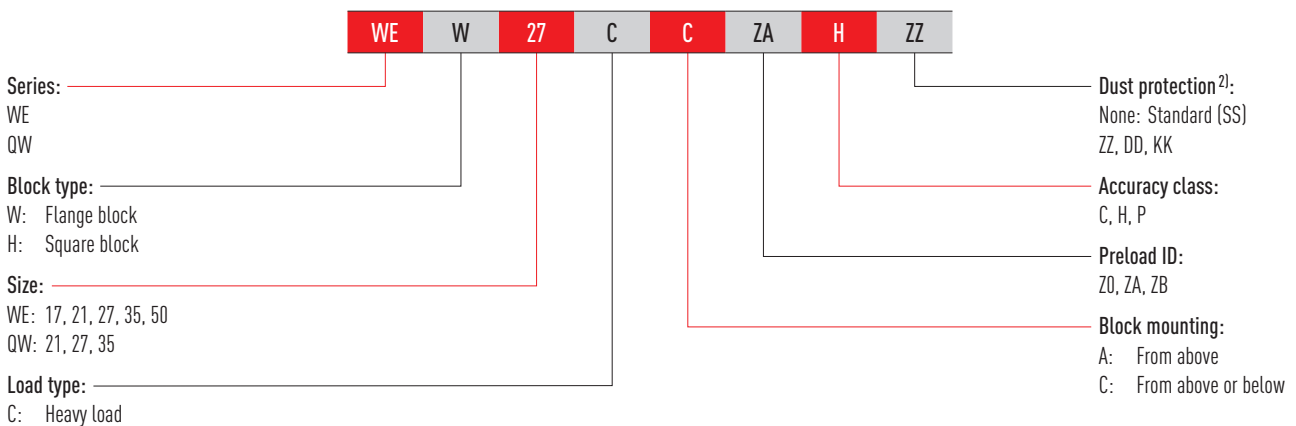

Order code for rail (unmounted)

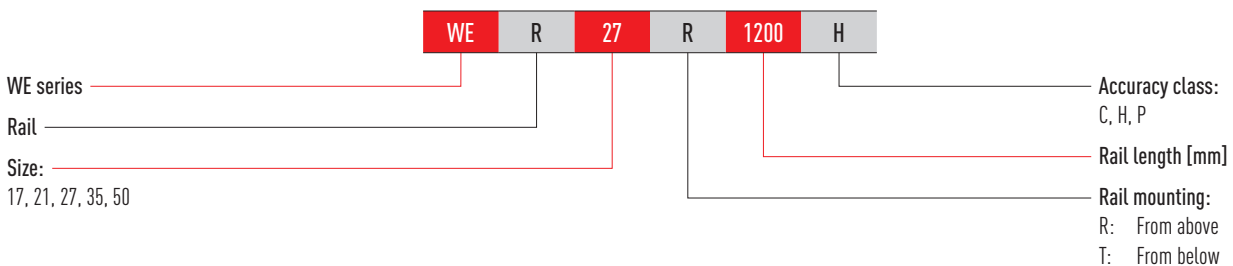

Note:

¹⁾ The figure 2 is also a quantity, i.e. one item of the above-mentioned article consists of a pair of rails. No number is specified for individual rails.

By default multi-part rails are delivered with staggered butt joints.

²⁾ You will find an overview of the individual sealing systems on [Page 22](#)

Linear guideways

WE and QW series

3.4.4 Block types

HIWIN provides square and flange blocks for its linear guideways. Given their low height and larger mounting surface, flange blocks are better suited for large loads.

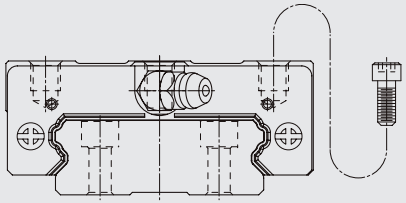
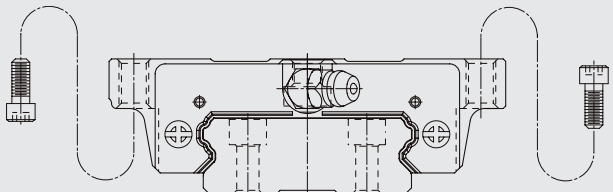
Type	Series/size	Structure	Height [mm]	Typical application
Square type	WEH-CA QWH-CA		17 – 50	<ul style="list-style-type: none"> ○ Automation ○ Handling industry ○ Measuring and test technology ○ Semiconductor industry ○ Injection moulding machines ○ Linear axes
Flange type	WEW-CC QWW-CC			

3.4.5 Preload

Definition

Every rail type can be preloaded based on the size of the balls. The curve shows that the rigidity doubles at higher preload. The WE/QW series offers three standard preload classes for various applications and conditions.

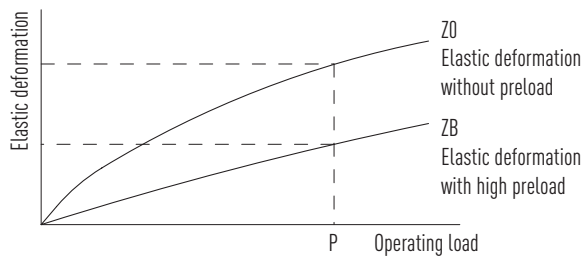

Preload ID

ID	Preload		Application	Sample applications
Z0	Light preload	$0 - 0.02 C_{dyn}$	Constant load direction, low impact, low accuracy needed	<ul style="list-style-type: none"> ○ Transport technology ○ Automatic packaging machines ○ X-Y axis in industrial machines ○ Welding machines
ZA	Medium preload	$0.03 - 0.05 C_{dyn}$	High accuracy needed	<ul style="list-style-type: none"> ○ Machining centres ○ Z axes for industrial machines ○ Eroding machines ○ NC lathes ○ Precision X-Y tables ○ Measuring technology
ZB	High preload	$0.06 - 0.08 C_{dyn}$	High rigidity needed, vibration and impact	<ul style="list-style-type: none"> ○ Machining centres ○ Grinding machines ○ NC lathes ○ Horizontal and vertical milling machines ○ Z axis of machine tools ○ High-performance cutting machines

3.4.6 Load ratings and torques

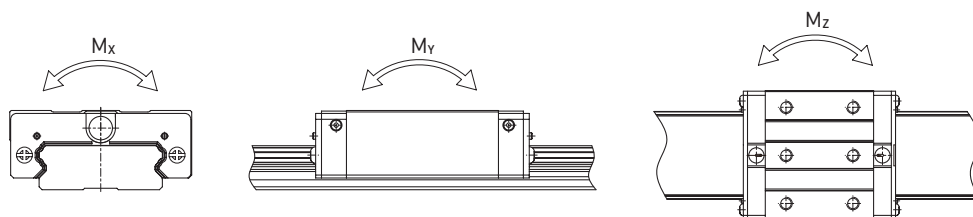

Table 3.63 Load ratings and torques for series WE/QW

Series/ size	Dynamic load rating C_{dyn} [N] ¹⁾	Static load rating C_0 [N]	Dynamic moment [Nm]			Static moment [Nm]		
			M_x	M_y	M_z	M_{0x}	M_{0y}	M_{0z}
WE_17C	5,230	9,640	82	34	34	150	62	62
WE_21C	7,210	13,700	122	53	53	230	100	100
QW_21C	9,000	12,100	156	67	67	210	90	90
WE_27C	12,400	21,600	242	98	98	420	170	170
QW_27C	16,000	22,200	303	144	144	420	200	200
WE_35C	29,800	49,400	893	405	405	1,480	670	670
WE_35C	36,800	49,200	1,129	486	486	1,510	650	650
WE_50C	61,520	97,000	2,556	1,244	1,244	4,030	1,960	1,960

¹⁾ Dynamic load rating for travel distance of 50,000 m

3.4.7 Rigidity

Rigidity depends on preload. Formula F 3.12 can be used to determine deformation depending on rigidity.

F 3.12

$$\delta = \frac{P}{k}$$

δ Deformation [μm]
 P Operating load [N]
 k Rigidity [N/ μm]

Table 3.64 Radial rigidity for series WE/QW

Load class	Series/ size	Rigidity depending on preload		
		Z0	ZA	ZB
Heavy load	WE_17C	128	166	189
	WE_21C	154	199	228
	QW_21C	140	176	200
	WE_27C	187	242	276
	QW_27C	183	229	260
	WE_35C	281	364	416
	QW_35C	277	348	395
	WE_50C	428	554	633

Unit: N/ μm

Linear guideways

WE and QW series

3.4.8 Dimensions of the WE/QW blocks

3.4.8.1 WEH/QWH

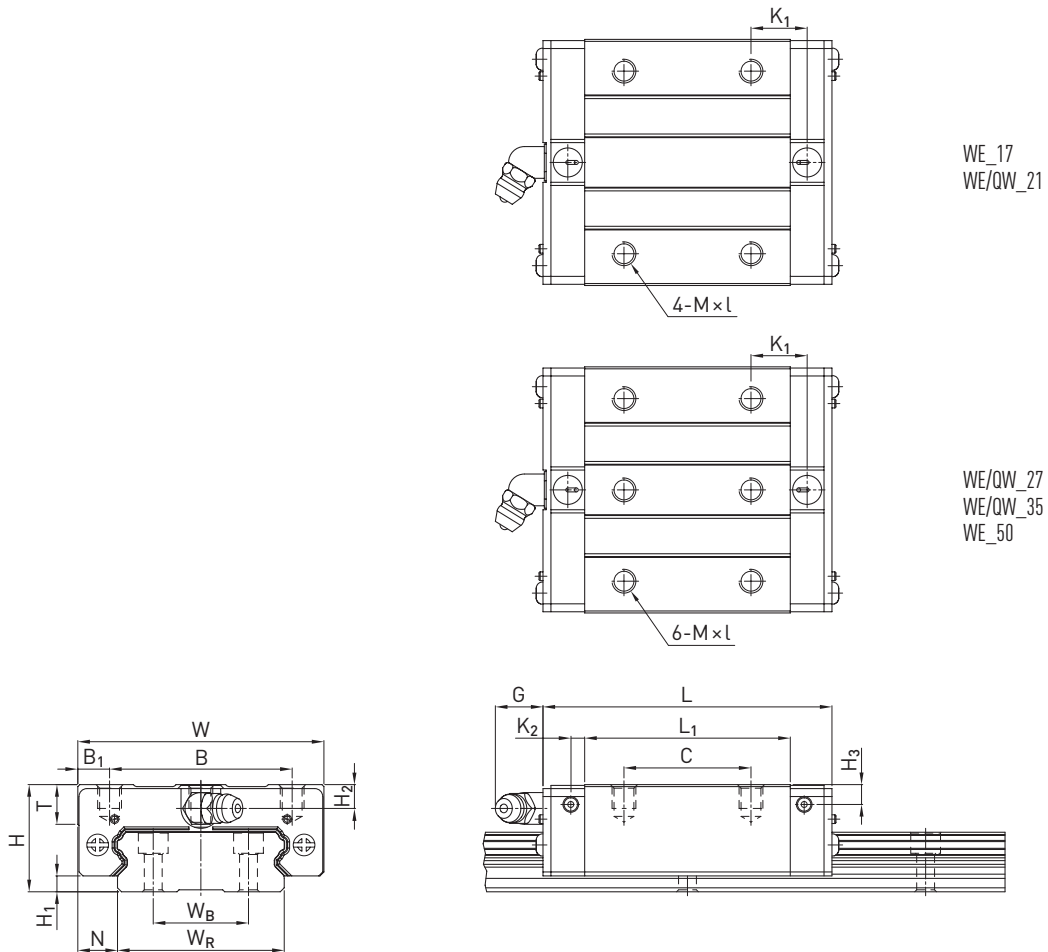

WE_17
WE/QW_21

WE/QW_27
WE/QW_35
WE_50

Table 3.65 Dimensions of the block

Series/ size	Installation dimensions [mm]			Dimensions of the block [mm]													Load ratings [N]		Weight [kg]
	H	H ₁	N	W	B	B ₁	C	L ₁	L	K ₁	K ₂	G	M × l	T	H ₂	H ₃	C _{dyn}	C ₀	
WEH17CA	17	2.5	8.5	50	29	10.5	15	35.0	50.6	—	3.10	4.9	M4 × 5	6.0	4.0	3.0	5,230	9,640	0.12
WEH21CA	21	3.0	8.5	54	31	11.5	19	41.7	59.0	14.68	3.65	12.0	M5 × 6	8.0	4.5	4.2	7,210	13,700	0.20
QWH21CA	21	3.0	8.5	54	31	11.5	19	41.7	59.0	14.68	3.65	12.0	M5 × 6	8.0	4.5	4.2	9,000	12,100	0.20
WEH27CA	27	4.0	10.0	62	46	8.0	32	51.8	72.8	14.15	3.50	12.0	M6 × 6	10.0	6.0	5.0	12,400	21,600	0.35
QWH27CA	27	4.0	10.0	62	46	8.0	32	56.6	73.2	15.45	3.15	12.0	M6 × 6	10.0	6.0	5.0	16,000	22,200	0.35
WEH35CA	35	4.0	15.5	100	76	12.0	50	77.6	102.6	18.35	5.25	12.0	M8 × 8	13.0	8.0	6.5	29,800	49,400	1.10
QWH35CA	35	4.0	15.5	100	76	12.0	50	73.0	107.0	21.5	5.50	12.0	M8 × 8	13.0	8.0	6.5	36,800	49,200	1.10
WEH50CA	50	7.5	20.0	130	100	15.0	65	112.0	140.0	28.05	6.00	12.9	M10 × 15	19.5	12.0	10.5	61,520	97,000	3.16

For dimensions of rail, see [Page 84](#), for standard and optional lubrication adapter, see [Page 128](#).

3.4.8.2 WEW/QWW

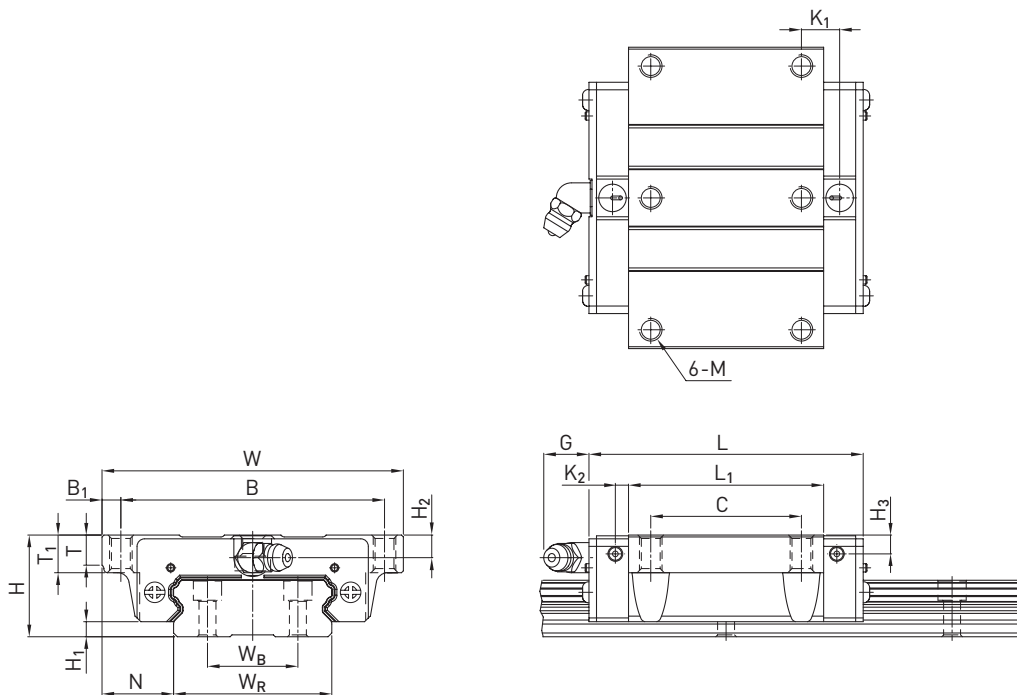

Table 3.66 Dimensions of the block

Series/ size	Installation dimensions [mm]			Dimensions of the block [mm]														Load ratings [N]		Weight [kg]
	H	H ₁	N	W	B	B ₁	C	L ₁	L	K ₁	K ₂	G	M	T	T ₁	H ₂	H ₃	C _{dyn}	C ₀	
WEW17CC	17	2.5	13.5	60	53	3.5	26	35.0	50.6	—	3.10	4.9	M4	5.3	6	4.0	3.0	5,230	9,640	0.13
WEW21CC	21	3.0	15.5	68	60	4.0	29	41.7	59.0	9.68	3.65	12.0	M5	7.3	8	4.5	4.2	7,210	13,700	0.23
QWW21CC	21	3.0	15.5	68	60	4.0	29	41.7	59.0	9.68	3.65	12.0	M5	7.3	8	4.5	4.2	9,000	12,100	0.23
WEW27CC	27	4.0	19.0	80	70	5.0	40	51.8	72.8	10.15	3.50	12.0	M6	8.0	10	6.0	5.0	12,400	21,600	0.43
QWW27CC	27	4.0	19.0	80	70	5.0	40	56.6	73.2	15.45	3.15	12.0	M6	8.0	10	6.0	5.0	16,000	22,200	0.43
WEW35CC	35	4.0	25.5	120	107	6.5	60	77.6	102.6	13.35	5.25	12.0	M8	11.2	14	8.0	6.5	29,800	49,400	1.26
QWW35CC	35	4.0	25.5	120	107	6.5	60	83.0	107.0	21.50	5.50	12.0	M8	11.2	14	8.0	6.5	36,800	49,200	1.26
WEW50CC	50	7.5	36.0	162	144	9.0	80	112.0	140.0	20.55	6.00	12.9	M10	14.0	18	12.0	10.5	61,520	97,000	3.71

For dimensions of rail, see [Page 84](#), for standard and optional lubrication adapter, see [Page 128](#).

Linear guideways

WE and QW series

3.4.9 Dimensions of the WE rail

3.4.9.1 Dimensions of WER_R

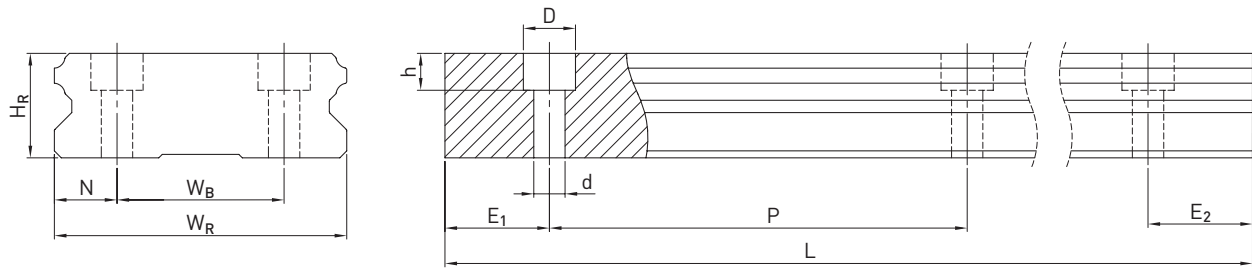

Table 3.67 Dimensions of rail WER_R

Series/ size	Assembly screw for rail [mm]	Dimensions of the rail [mm]							Max. length [mm]	Max. length $E_1 = E_2$ [mm]	Min. length [mm]	$E_{1/2}$ min [mm]	$E_{1/2}$ max [mm]	Weight [kg/m]
		W_R	W_B	H_R	D	h	d	P						
WER17R	M4 × 12	33	18	9.3	7.5	5.3	4.5	40	4,000	3,960	92	6	34	2.2
WER21R	M4 × 16	37	22	11.0	7.5	5.3	4.5	50	4,000	3,950	112	6	44	3.0
WER27R	M4 × 20	42	24	15.0	7.5	5.3	4.5	60	4,000	3,900	132	6	54	4.7
WER35R	M6 × 25	69	40	19.0	11.0	9.0	7.0	80	4,000	3,920	176	8	72	9.7
WER50R	M8 × 30	90	60	24.0	14.0	12.0	9.0	80	4,000	3,920	178	9	71	14.6

3.4.9.2 Dimensions of WER_T

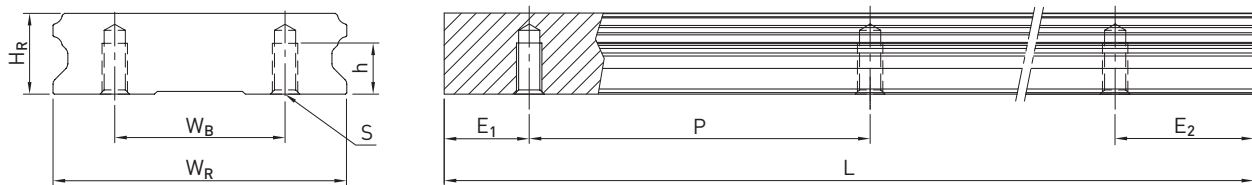

Table 3.68 Dimensions of rail WER_T

Series/ size	Dimensions of the rail [mm]							Max. length [mm]	Max. length $E_1 = E_2$ [mm]	Min. length [mm]	$E_{1/2}$ min [mm]	$E_{1/2}$ max [mm]	Weight [kg/m]
	W_R	W_B	H_R	S	h	P							
WER21T	37	22	11	M4	7.0	50	4,000	3,950	112	6	44	3.0	
WER27T	42	24	15	M5	7.5	60	4,000	3,900	132	6	54	4.7	
WER35T	69	40	19	M6	12.0	80	4,000	3,920	176	8	72	9.7	

Note:

1. The tolerance for E is $+0.5$ to -1 mm for standard rails and 0 to -0.3 mm for joints.
2. If the $E_{1/2}$ dimensions are not indicated, the maximum possible number of mounting holes will be determined under consideration of $E_{1/2}$ min.
3. The rails are shortened to the required length. If the $E_{1/2}$ dimensions are not indicated, these will be carried out symmetrically.

3.4.9.3 Calculating the length of rails

HIWIN offers rails in customized lengths. To prevent the risk of the end of the rail becoming unstable, the value E must not exceed half of the distance between the mounting holes (P). At the same time, the value $E_{1/2}$ should be between $E_{1/2}$ min and $E_{1/2}$ max so that the mounting hole does not rupture.

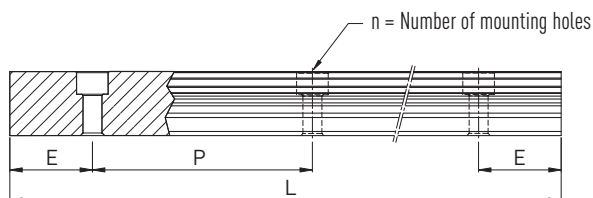

F 3.13

$$L = (n - 1) \times P + E_1 + E_2$$

L Total length of the rail [mm]
n Number of mounting holes
P Distance between two mounting holes [mm]
 $E_{1/2}$ Distance from the middle of the last mounting hole to the end of the rail [mm]

3.4.9.4 Tightening torques for mounting bolts

Insufficient tightening of the mounting bolts compromises the function and precision of the linear guideways. The following tightening torques are recommended for the screw sizes.

Table 3.69 Tightening torques of the mounting bolts according to ISO 4762-12.9

Series/size	Screw size	Torque [Nm]	Series/size	Screw size	Torque [Nm]
WE_17	M4 × 12	4	WE/QW_35	M6 × 25	14
WE/QW_21	M4 × 16	4	WE_50	M8 × 30	31
WE/QW_27	M4 × 20	4			

3.4.9.5 Cover caps for mounting holes of rails

The cover caps are used to keep the mounting holes free of chips and dirt. The standard plastic caps are provided with each rail. Optional cover caps must be ordered separately.



Table 3.70 Cover caps for mounting holes of rails

Rail	Screw	Article number			Ø D [mm]	Height H [mm]
		Plastic (200 pcs.)	Brass	Steel		
WER17R	M4	5-002218	5-001344	—	7.5	1.2
WER21R	M4	5-002218	5-001344	—	7.5	1.2
WER27R	M4	5-002218	5-001344	—	7.5	1.2
WER35R	M6	5-002221	5-001355	5-001357	11.0	2.8
WER50R	M8	5-002222	5-001360	5-001362	14.0	3.5

Linear guideways

WE and QW series

3.4.10 Sealing systems

Various sealing systems are available for HIWIN blocks. You will find an overview on [Page 22](#). The table below shows the total length of the blocks with the different sealing systems. Sealing systems suitable for these sizes are available.

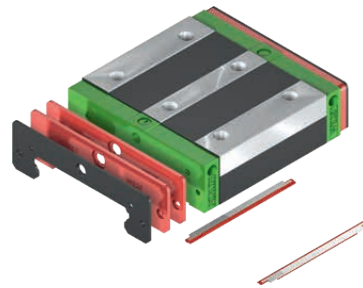

Table 3.71 Total length of block with different sealing systems

Series/ size	Total length L			
	SS	DD	ZZ	KK
WE_17C	50.6	53.8	52.6	55.8
WE/QW_21C	59.0	63.0	61.0	65.0
WE/QW_27C	72.8	76.8	74.8	78.8
WE/QW_35C	102.6	106.6	105.6	109.6
WE_50C	140.0	145.0	142.0	147.0

Unit: mm

3.4.11 Designation of sealing sets

The sealing sets are always supplied along with the assembly material and include the parts needed in addition to the standard seal.

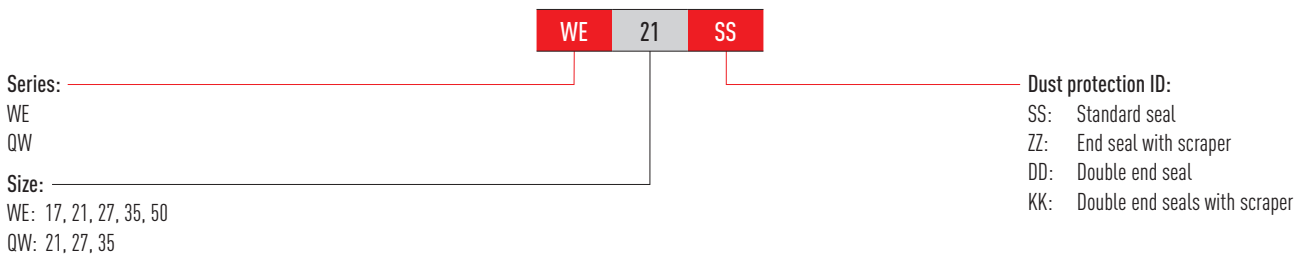

3.4.12 Friction

The table shows the maximum frictional resistance of the individual end seal. Depending on sealing setup (SS, ZZ, DD, KK), the value may have to be multiplied. The values indicated apply to blocks on uncoated rails. Higher friction forces occur on coated rails.

Table 3.72 Frictional resistance of single-lipped seals

Series/size	Friction force [N]	Series/size	Friction force [N]
WE_17	1.2	WE/QW_35	3.9
WE/QW_21	2.0	WE_50	3.9
WE/QW_27	2.9		

3.4.13 Tolerances depending on accuracy class

The WE and QW series are available in five accuracy classes depending on parallelism between block and rail, height accuracy H and accuracy of width N. The choice of accuracy class is determined by the machine requirements.

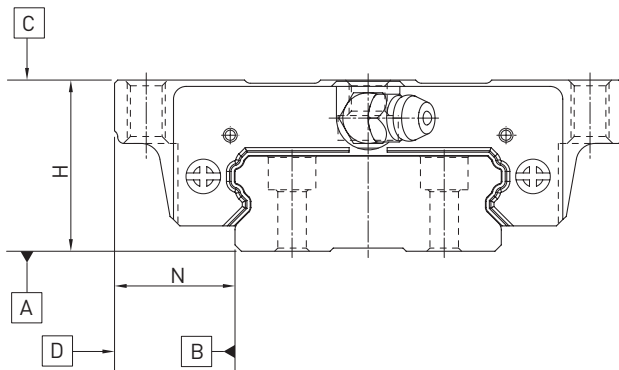

3.4.14 Parallelism

Parallelism of stop surfaces D and B of block and rail and parallelism of top of block C to mounting surface A of rail. Ideal linear guideway installation is required, as is a measurement in the centre of the block.

Table 3.73 Tolerance of parallelism between block and rail

Rail length [mm]	Accuracy class				
	C	H	P	SP	UP
- 100	12	7	3	2	2
100 - 200	14	9	4	2	2
200 - 300	15	10	5	3	2
300 - 500	17	12	6	3	2
500 - 700	20	13	7	4	2
700 - 900	22	15	8	5	3
900 - 1100	24	16	9	6	3
1100 - 1500	26	18	11	7	4
1500 - 1900	28	20	13	8	4
1900 - 2500	31	22	15	10	5
2500 - 3100	33	25	18	11	6
3100 - 3600	36	27	20	14	7
3600 - 4000	37	28	21	15	7

Unit: μm

Linear guideways

WE and QW series

3.4.14.1 Accuracy – height and width

Height tolerance of H

Permissible absolute dimension variance of height H, measured between centre of screw-on surface C and underside of rail A, with block in any position on the rail.

Height variance of H

Permissible variance of height H between several blocks on a rail, measured in the same rail position.

Width tolerance of N

Permissible absolute dimension variance of width N, measured between centre of screw-on surfaces D and B, with block in any position on the rail.

Width variance of N

Permissible variance of width N between several blocks on a rail, measured in the same rail position.

Table 3.74 Height and width tolerances

Series/size	Accuracy class	Height tolerance of H	Width tolerance of N	Height variance of H	Width variance of N
WE_17, 21 QW_21	C (Normal)	± 0.1	± 0.1	0.02	0.02
	H (High)	± 0.03	± 0.03	0.01	0.01
	P (Precision)	$0/-0.03^{1)}$ $\pm 0.015^{2)}$	$0/-0.03^{1)}$ $\pm 0.015^{2)}$	0.006	0.006
	SP (Super precision)	$0/-0.015$	$0/-0.015$	0.004	0.004
	UP (Ultra precision)	$0/-0.008$	$0/-0.008$	0.003	0.003
WE_27, 35 QW_27, 35	C (Normal)	± 0.1	± 0.1	0.02	0.03
	H (High)	± 0.04	± 0.04	0.015	0.015
	P (Precision)	$0/-0.04^{1)}$ $\pm 0.02^{2)}$	$0/-0.04^{1)}$ $\pm 0.02^{2)}$	0.007	0.007
	SP (Super precision)	$0/-0.02$	$0/-0.02$	0.005	0.005
	UP (Ultra precision)	$0/-0.01$	$0/-0.01$	0.003	0.003
WE_50	C (Normal)	± 0.1	± 0.1	0.03	0.03
	H (High)	± 0.05	± 0.05	0.02	0.02
	P (Precision)	$0/-0.05^{1)}$ $\pm 0.025^{2)}$	$0/-0.05^{1)}$ $\pm 0.025^{2)}$	0.01	0.01
	SP (Super precision)	$0/-0.03$	$0/-0.03$	0.01	0.01
	UP (Ultra precision)	$0/-0.02$	$0/-0.02$	0.01	0.01

Unit: mm

¹⁾ Fully assembled linear guideway

²⁾ Unmounted linear guideway

3.4.14.2 Permissible mounting surface tolerances

Once the requirements relating to the accuracy of the mounting surfaces are met, the good accuracy, rigidity and lifetime of the WE and QW series linear guideways are achieved.

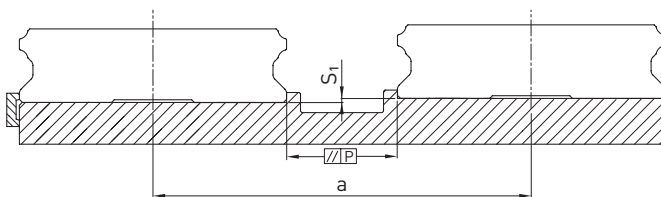

Tolerance for the parallelism of the reference surface (P):

Table 3.75 Maximum tolerance for parallelism (P)

Series/size	Preload class		
	Z0	ZA	ZB
WE_17	20	15	9
WE/QW_21	25	18	9
WE/QW_27	25	20	13
WE/QW_35	30	22	20
WE_50	40	30	27

Unit: μm

Tolerance for the height of the reference surface (S₁):

F 3.14 $S_1 = a \times K$

- S₁ Max. height tolerance [mm]
- a Distance between rails [mm]
- K Coefficient of the height tolerance

Table 3.76 Coefficient of the height tolerance (K)

Series/size	Preload class		
	Z0	ZA	ZB
WE_17	1.3×10^{-4}	0.4×10^{-4}	—
WE/QW_21	2.6×10^{-4}	1.7×10^{-4}	0.9×10^{-4}
WE/QW_27	2.6×10^{-4}	1.7×10^{-4}	0.9×10^{-4}
WE/QW_35	2.6×10^{-4}	1.7×10^{-4}	1.4×10^{-4}
WE_50	3.4×10^{-4}	2.2×10^{-4}	1.8×10^{-4}

3.4.15 Shoulder heights and fillets

Imprecise shoulder heights and fillets of mounting surfaces compromise precision and may lead to conflicts with the block or rail profiles. The following shoulder heights and edge profiles must be observed in order to avoid assembly problems.

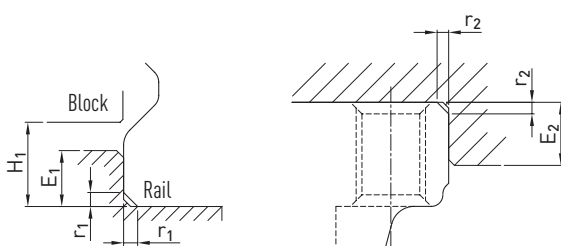

Table 3.77 Shoulder heights and fillets

Series/size	Max. edge radius r ₁	Max. edge radius r ₂	Shoulder height of reference edge of rail E ₁	Shoulder height of reference edge of block E ₂	Clearance under block H ₁
WE_17	0.4	0.4	2.0	4.0	2.5
WE/QW_21	0.4	0.4	2.5	5.0	3.0
WE/QW_27	0.5	0.5	3.0	7.0	4.0
WE/QW_35	0.5	0.5	3.5	10.0	4.0
WE_50	0.8	0.8	6.0	10.0	7.5

Unit: mm

Linear guideways

MG series

3.5 MG series

3.5.1 Properties of the linear guideway, series MGN

The HIWIN linear guideway of the MGN series is based on proven HIWIN technology. The Gothic arch contact design absorbs loads in all directions and is particularly rigid and precise. Given its compact and lightweight design, it is particularly suited to use in small devices.

3.5.2 Design of the MGN series

- 2-row recirculation ball bearing guide
- Gothic arch contact design
- Stainless steel block and balls
- Rails made from standard or stainless steel
- Compact and lightweight design
- Balls are secured in the block by retaining wire
- Grease nipple available for MGN15
- End seal
- Interchangeable models are available in defined accuracy classes

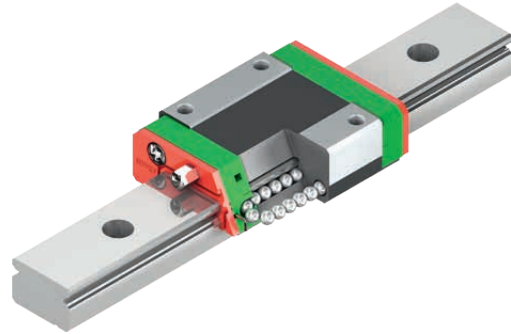

Design of the MGN series

3.5.3 Properties of the linear guideway, series MGW

The HIWIN linear guideway of the MGW series is based on proven HIWIN technology. The Gothic arch contact design absorbs loads in all directions and is particularly rigid and precise. The MGW series has a wider rail than the MGN series so can absorb considerably higher load torques.

3.5.4 Design of the MGW series

- 2-row recirculation ball bearing guide
- Gothic arch contact design
- Stainless steel block and balls
- Rails made from standard or stainless steel
- Compact and lightweight design
- Balls are secured in the block by retaining wire
- Grease nipple available for MGW15
- End seal
- Interchangeable models are available in defined accuracy classes

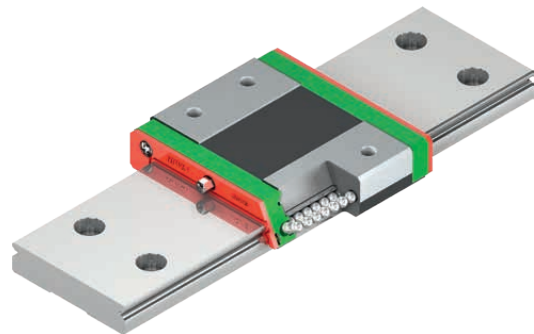

Design of the MGW series

3.5.5 Applications of the MG series

The MGN and MGW series can be used in many sectors, e.g. in the semiconductor industry, PCB population, medical technology, robot applications, measurement devices, office automation and other sectors needing miniature guides.

3.5.6 Order codes for the MG series

For MGN and MGW linear guideways, a distinction is made between fully assembled and unmounted models. The dimensions of both models are the same. The main difference is that the block and rail in the unmounted models can be freely interchanged. Block and rail can therefore be ordered separately and fitted by the customer.

Order code for linear guideway (fully assembled)

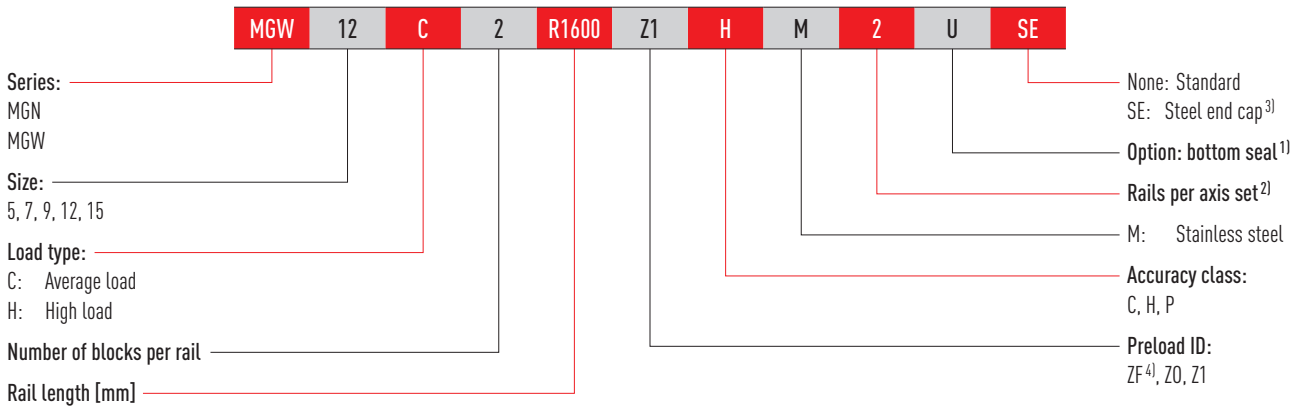

Order code for block (unmounted)

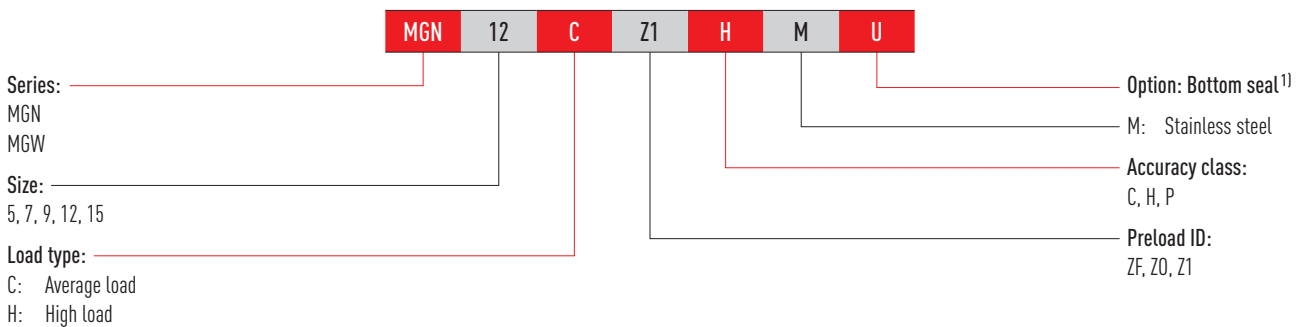

Order code for rail (unmounted)

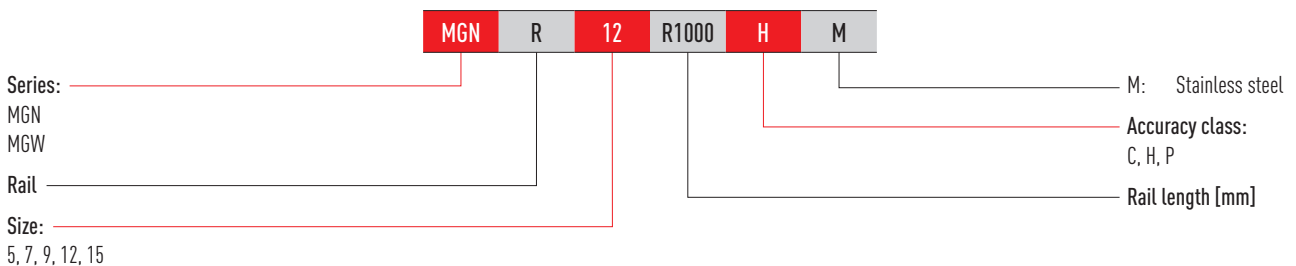

Note:

¹⁾ Available for MGN and MGW series in sizes 12 and 15.

²⁾ The figure 2 is also a quantity, i.e. one item of the above-mentioned article consists of a pair of rails. No number is specified for individual rails. By default multi-part rails are delivered with staggered butt joints.

³⁾ Available for MGN07, 09, 12, 15 and MGW12, 15.

⁴⁾ Not available for paired rails and for MG05.

Linear guideways

MG series

3.5.7 Block types

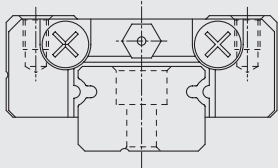
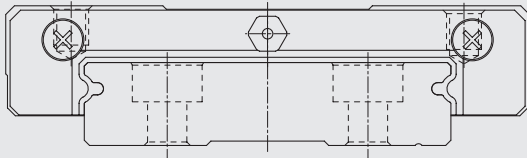
Table 3.78 Block types				
Type	Series/size	Structure	Height [mm]	Typical application
Narrow type	MGN-C MGN-H		8 – 16	<ul style="list-style-type: none"> ○ Printers ○ Robotics ○ Precision measuring equipment ○ Semiconductor industry
Wide type	MGW-C MGW-H		9 – 16	

3.5.8 Rail types

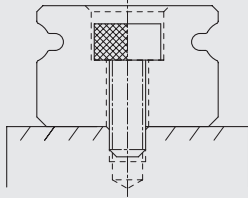
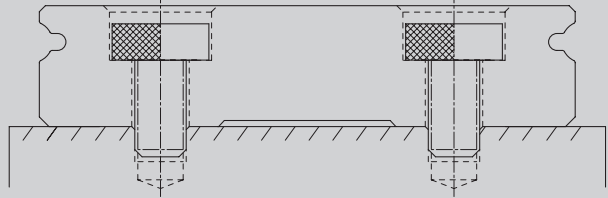
Table 3.79 Rail types	
Fastening from above	
	
MGN_R	MGW_R

3.5.9 Preload

The MGN/MGW series offers three preload classes for various applications.

Table 3.80 Preload ID

ID	Preload	Accuracy class
ZF	Slight play: 4 – 10 µm	C, H
Z0	Zero-play, very slight preload	C – P
Z1	Slight preload: 0 – 0.02 C _{dyn}	C – P

¹⁾ Not available for size 5

3.5.10 Load ratings and torques

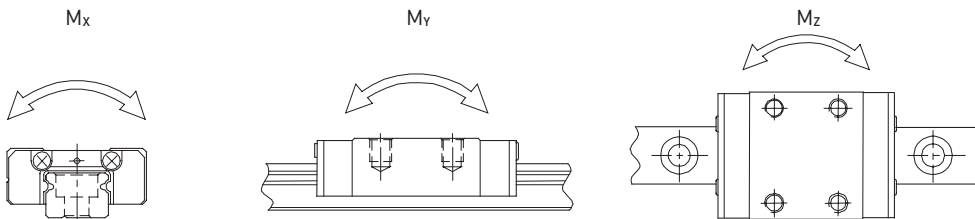

Table 3.81 Load ratings and torques for MG series

Series/size	Dynamic load rating C _{dyn} [N] ¹⁾	Static load rating C ₀ [N]	Dynamic moment [Nm]			Static moment [Nm]		
			M _x	M _y	M _z	M _{0x}	M _{0y}	M _{0z}
MGN05C	540	840	1.3	0.8	0.8	2.0	1.3	1.3
MGN05H	670	1,080	1.6	1.4	1.4	2.6	2.3	2.3
MGN07C	980	1,245	3.0	2.0	2.0	4.7	2.8	2.8
MGN07H	1,370	1,960	5.0	3.0	3.0	7.6	4.8	4.8
MGN09C	1,860	2,550	8.0	5.0	5.0	11.8	7.4	7.4
MGN09H	2,550	4,020	12.4	11.8	11.8	19.6	18.6	18.6
MGN12C	2,840	3,920	18.0	10.0	10.0	25.5	13.7	13.7
MGN12H	3,720	5,880	24.0	23.0	23.0	38.2	36.3	36.3
MGN15C	4,610	5,590	37.0	18.0	18.0	45.1	21.6	21.6
MGN15H	6,370	9,110	52.0	41.0	41.0	73.5	57.8	57.8
MGW05C	680	1,180	3.2	1.6	1.6	5.5	2.7	2.7
MGW07C	1,370	2,060	10.0	4.0	4.0	15.7	7.1	7.1
MGW07H	1,770	3,140	13.0	8.0	8.0	23.5	15.5	15.5
MGW09C	2,750	4,120	27.0	12.0	12.0	40.1	18.0	18.0
MGW09H	3,430	5,890	32.0	20.0	20.0	54.5	34.0	34.0
MGW12C	3,920	5,590	50.0	19.0	19.0	70.3	27.8	27.8
MGW12H	5,100	8,240	64.0	36.0	36.0	102.7	57.4	57.4
MGW15C	6,770	9,220	149.0	42.0	42.0	199.3	56.7	56.7
MGW15H	8,930	13,380	196.0	80.0	80.0	299.0	122.6	122.6

¹⁾ Dynamic load rating for travel distance of 50,000 m

Linear guideways

MG series

3.5.11 Rigidity

Rigidity depends on preload. Formula F 3.15 can be used to determine deformation depending on rigidity.

F 3.15

$$\delta = \frac{P}{k}$$

δ Deformation [μm]
 P Operating load [N]
 k Rigidity [N/ μm]

Table 3.82 Radial rigidity for series MGN

Load Class	Series/ size	Preload	
		Z0	Z1
Average load	MGN07C	26	33
	MGN09C	37	48
	MGN12C	44	56
	MGN15C	57	74
High load	MGN07H	39	51
	MGN09H	56	73
	MGN12H	63	81
	MGN15H	87	113

Unit: N/ μm

Table 3.83 Radial rigidity for series MGW

Load Class	Series/ size	Preload	
		Z0	Z1
Average load	MGW07C	38	49
	MGW09C	55	71
	MGW12C	63	81
	MGW15C	78	101
High load	MGW07H	54	70
	MGW09H	74	95
	MGW12H	89	114
	MGW15H	113	145

Unit: N/ μm

3.5.12 Dimensions of the MG block

3.5.12.1 MGN

MGN05

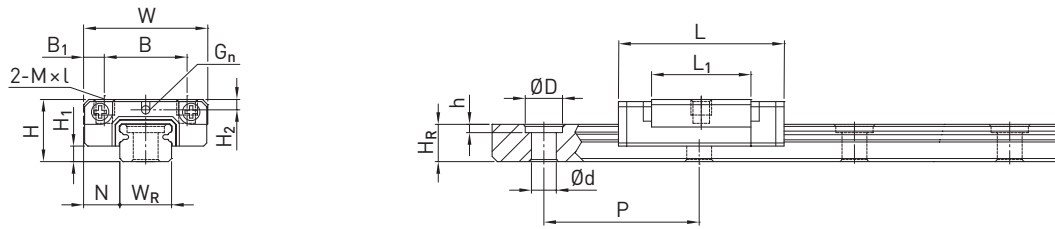

MGN07, MGN09, MGN12

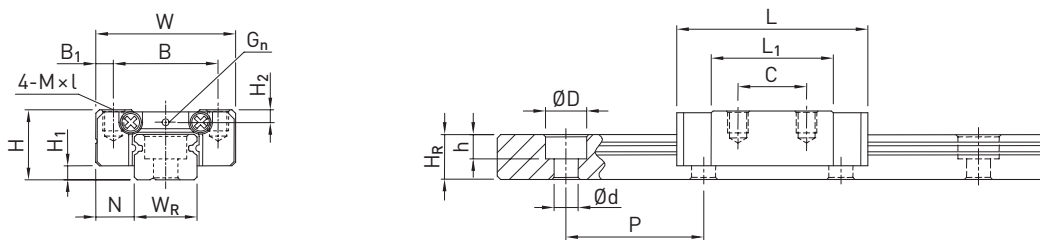

MGN15

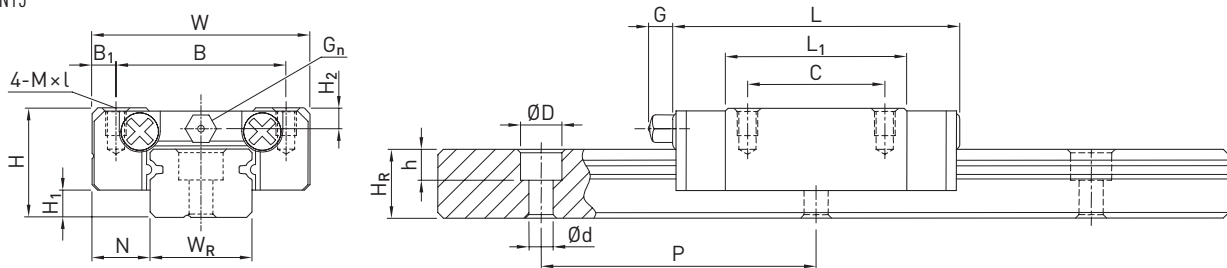

Table 3.84 Dimensions of the block

Series/ size	Installation dimensions [mm]			Dimensions of the block [mm]										Load ratings [N]		Weight [kg]
	H	H ₁	N	W	B	B ₁	C	L ₁	L	G	G _n	M × l	H ₂	C _{dyn}	C ₀	
MGN05C	6	1.5	3.5	12	8	2.0	—	9.6	16.0	—	Ø0.8	M2 × 1.5	1.0	540	840	0.008
MGN05H							—	12.6	19.0					670	1,080	0.010
MGN07C	8	1.5	5.0	17	12	2.5	8	13.5	22.5	—	Ø1.2	M2 × 2.5	1.5	980	1,245	0.010
MGN07H							13	21.8	30.8					1,372	1,960	0.020
MGN09C	10	2.0	5.5	20	15	2.5	10	18.9	28.9	—	Ø1.4	M3 × 3	1.8	1,860	2,550	0.020
MGN09H							16	29.9	39.9					2,550	4,020	0.030
MGN12C	13	3.0	7.5	27	20	3.5	15	21.7	34.7	—	Ø2	M3 × 3.5	2.5	2,840	3,920	0.030
MGN12H							20	32.4	45.4					3,720	5,880	0.050
MGN15C	16	4.0	8.5	32	25	3.5	20	26.7	42.1	4.5	M3	M3 × 4	3.0	4,610	5,590	0.060
MGN15H							25	43.4	58.8					6,370	9,110	0.090

For dimensions of rail, see [Page 97](#), for standard and optional lubrication adapter, see [Page 128](#).

Linear guideways

MG series

3.5.12.2 MGW

MGW05

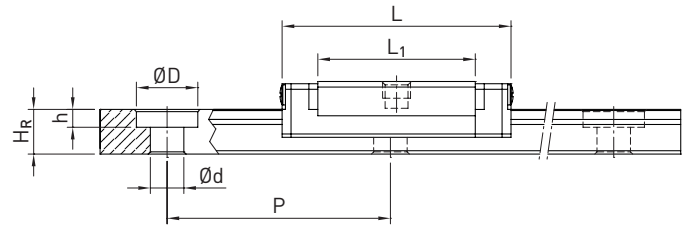
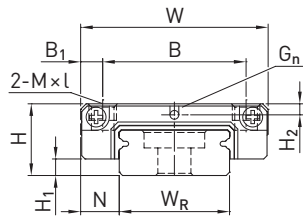

MGW07, MGW09, MGW12

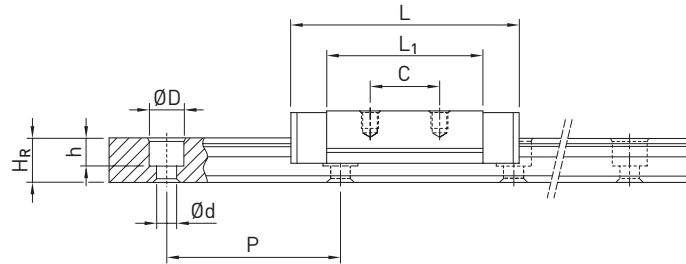
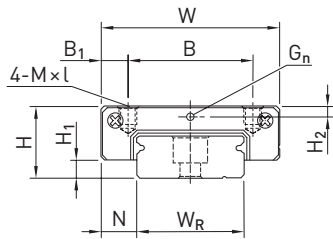

MGW15

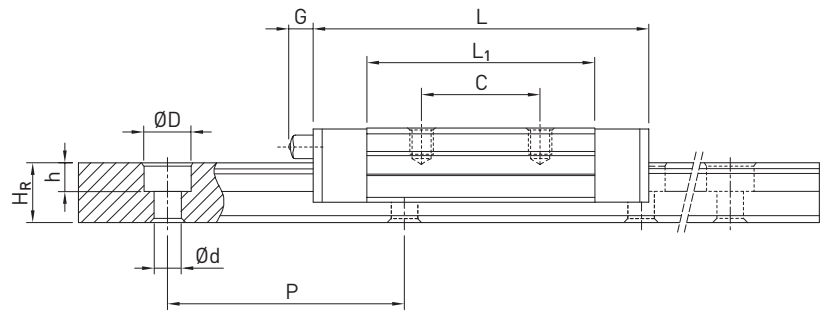
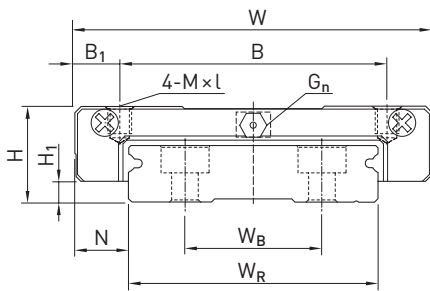

Table 3.85 Dimensions of the block

Series/ size	Installation dimensions [mm]			Dimensions of the block [mm]										Load ratings [N]		Weight [kg]
	H	H ₁	N	W	B	B ₁	C	L ₁	L	G	G _n	M × l	H ₂	C _{dyn}	C ₀	
MGW05C	6.5	1.5	3.5	17	13	2.0	—	14.1	20.5	—	Ø1.2	M2.5 × 1.5	1.00	680	1,180	0.02
MGW07C	9.0	1.9	5.5	25	19	3.0	10	21.0	31.2	—	Ø1.2	M3 × 3	1.85	1,370	2,060	0.02
MGW07H							19	30.8	41.0	1,770				3,140	0.03	
MGW09C	12.0	2.9	6.0	30	21	4.5	12	27.5	39.3	—	Ø1.4	M3 × 3	2.40	2,750	4,120	0.04
MGW09H					23	3.5	24	38.5	50.7	3,430				5,890	0.06	
MGW12C	14.0	3.4	8.0	40	28	6.0	15	31.3	46.1	—	Ø2	M3 × 3.6	2.80	3,920	5,590	0.07
MGW12H							28	45.6	60.4	5,100				8,240	0.10	
MGW15C	16.0	3.4	9.0	60	45	7.5	20	38.0	54.8	5.2	M3	M4 × 4.2	3.20	6,770	9,220	0.14
MGW15H							35	57.0	73.8	8,930				13,380	0.22	

For dimensions of rail, see [Page 97](#), for standard and optional lubrication adapter, see [Page 128](#).

3.5.13 Dimensions of the MG rail

3.5.13.1 Dimensions of MGN_R

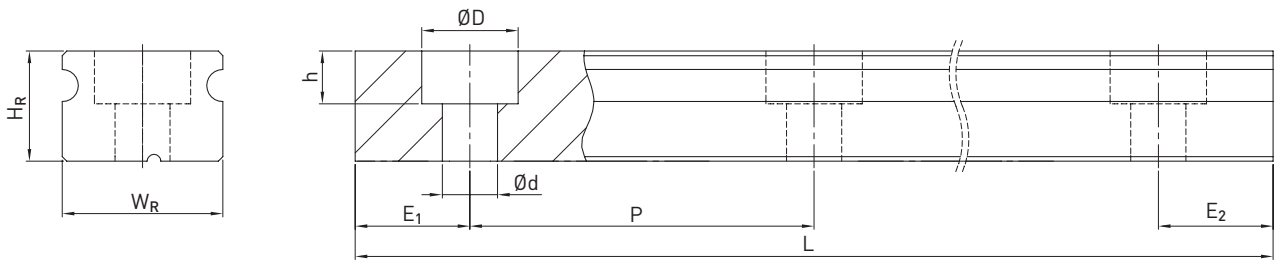

Table 3.86 Dimensions of rail MGN_R

Series/ size	Assembly screw for rail [mm]	Dimensions of rail [mm]						Max. length [mm]	Max. length $E_1 = E_2$ [mm]	Min. length [mm]	$E_{1/2}$ min [mm]	$E_{1/2}$ max [mm]	Weight [kg/m]
		W_R	H_R	D	h	d	P						
MGNR05R	M2 × 8	5	3.6	3.6	0.8	2.4	15	250	225	38	4	11	0.15
MGNR07R	M2 × 8	7	4.8	4.2	2.3	2.4	15	600	585	40	5	12	0.22
MGNR09R	M3 × 10	9	6.5	6.0	3.5	3.5	20	1,200	1,180	50	5	15	0.38
MGNR12R	M3 × 10	12	8.0	6.0	4.5	3.5	25	2,000	1,975	60	5	20	0.65
MGNR15R	M3 × 12	15	10.0	6.0	4.5	3.5	40	2,000	1,960	92	6	34	1.06

3.5.13.2 Dimensions of MGW_R

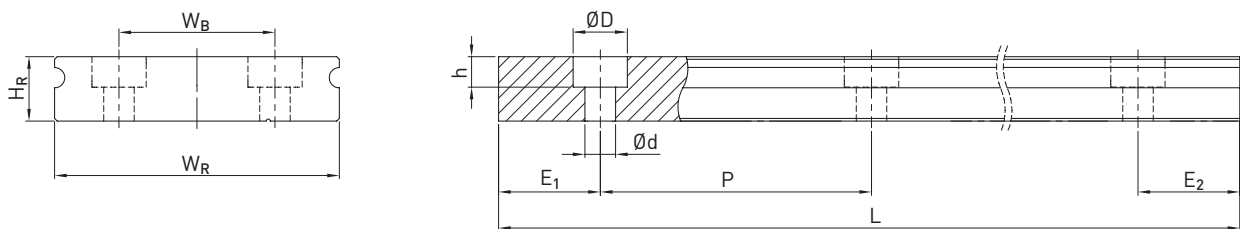

Table 3.87 Dimensions of rail MGW_R

Series/ size	Assembly screw for rail [mm]	Dimensions of the rail [mm]							Max. length [mm]	Max. length $E_1 = E_2$ [mm]	Min. length [mm]	$E_{1/2}$ min [mm]	$E_{1/2}$ max [mm]	Weight [kg/m]
		W_R	H_R	W_B	D	h	d	P						
MGWR05R	M2.5 × 8	10	4.0	—	5.5	1.6	3.0	20	250	220	48	4	11	0.34
MGWR07R	M3 × 8	14	5.2	—	6.0	3.2	3.5	30	600	570	72	6	24	0.51
MGWR09R	M3 × 10	18	7.0	—	6.0	4.5	3.5	30	2,000	1,170	72	6	24	0.91
MGWR12R	M4 × 12	24	8.5	—	8.0	4.5	4.5	40	2,000	1,960	96	8	32	1.49
MGWR15R	M4 × 16	42	9.5	23	8.0	4.5	4.5	40	2,000	1,960	96	8	32	2.86

Note:

1. The tolerance for E is $+0.5$ to -1 mm for standard rails and 0 to -0.3 mm for joints.
2. If the $E_{1/2}$ dimensions are not indicated, the maximum possible number of mounting holes will be determined under consideration of $E_{1/2}$ min.
3. The rails are shortened to the required length. If the $E_{1/2}$ dimensions are not indicated, these will be carried out symmetrically

Linear guideways

MG series

3.5.13.3 Calculating the length of rails

HIWIN offers rails in customized lengths. To prevent the risk of the end of the rail becoming unstable, the value E must not exceed half of the distance between the mounting holes (P). At the same time, the value $E_{1/2}$ should be between $E_{1/2}$ min and $E_{1/2}$ max so that the mounting hole does not rupture.

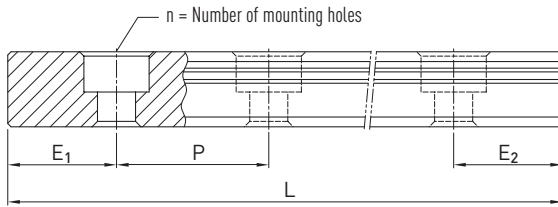

F 3.16

$$L = (n - 1) \times P + E_1 + E_2$$

- L Total length of the rail [mm]
- n Number of mounting holes
- P Distance between two mounting holes [mm]
- $E_{1/2}$ Distance from the middle of the last mounting hole to the end of the rail [mm]

3.5.13.4 Tightening torques for mounting bolts

Insufficient tightening of the mounting bolts strongly compromises the precision of the linear guideway; the following tightening torques are therefore recommended for the relevant screw sizes.

Table 3.88 Tightening torques of the mounting bolts according to ISO 4762-12.9

Series/size	Screw size	Torque [Nm]	Series/size	Screw size	Torque [Nm]
MGN05	M2 × 6	0.6	MGW05	M2.5 × 7	1.2
MGN07	M2 × 6	0.6	MGW07	M3 × 6	2.0
MGN09	M3 × 8	2.0	MGW09	M3 × 8	2.0
MGN12	M3 × 8	2.0	MGW12	M4 × 8	4.0
MGN15	M3 × 10	2.0	MGW15	M4 × 10	4.0

3.5.13.5 Cover caps for mounting holes of rails

The cover caps are used to keep the mounting holes free of chips and dirt. The standard plastic caps are provided with each rail.



Table 3.89 Cover caps for mounting holes of rails

Rail	Screw	Article number		Ø D [mm]	Height H [mm]
		Plastic (200pcs.)	Brass		
MGNR09R	M3	5-002217 ¹⁾	5-001340 ¹⁾	6	1.2
MGNR12R	M3	5-002217	5-001340	6	1.2
MGNR15R	M3	5-002217	5-001340	6	1.2
MGWR09R	M3	5-002217	5-001340	6	1.2
MGWR12R	M4	5-002219	—	8	1.2
MGWR15R	M4	5-002219	—	8	1.2

¹⁾ Standard: without cover caps, state in order if required. Only possible with cylinder head screws with a low head according to DIN 7984

3.5.14 Dust protection

The blocks of the MG series are equipped on both sides with an end seal to protect against dirt as standard. In addition seals for the bottom of the block can be ordered using the "+U" identifier in the order code. They are available as options for sizes 12 and 15. They cannot be fitted for sizes 5, 7 and 9 due to the limited installation space H_1 . When fitting a bottom seal, the side mounting surface of the rail must not exceed H_1 .

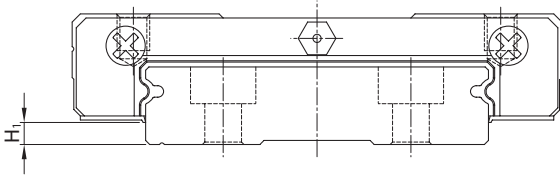
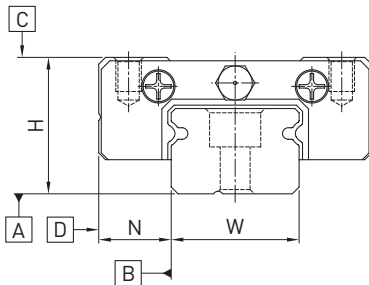

Table 3.90 Installation space H_1

Series/size	Bottom seal	H_1	Series/size	Bottom seal	H_1
MGN05	—	—	MGW05	—	—
MGN07	—	—	MGW07	—	—
MGN09	—	—	MGW09	—	—
MGN12	●	2.0	MGW12	●	2.6
MGN15	●	3.0	MGW15	●	2.6

3.5.15 Tolerances depending on accuracy class

The MG series are available in three accuracy classes depending on parallelism between block and rail, height accuracy H and accuracy of width N . The choice of accuracy class is determined by the machine requirements.



Linear guideways

MG series

3.5.15.1 Parallelism

Parallelism of stop surfaces D and B of block and rail and parallelism of top of block C to mounting surface A of rail. Ideal linear guideway installation is required, as is a measurement in the centre of the block.

Table 3.91 Tolerance of parallelism between block and rail

Rail length [mm]	Accuracy class		
	C	H	P
– 50	12	6	2.0
50 – 80	13	7	3.0
80 – 125	14	8	3.5
125 – 200	15	9	4.0
200 – 250	16	10	5.0
250 – 315	17	11	5.0
315 – 400	18	11	6.0
400 – 500	19	12	6.0
500 – 630	20	13	7.0
630 – 800	22	14	8.0
800 – 1000	23	16	9.0
1000 – 1200	25	18	11.0
1200 – 1300	25	18	11.0
1300 – 1400	26	19	12.0
1400 – 1500	27	19	12.0
1500 – 1600	28	20	13.0
1600 – 1700	29	20	14.0
1700 – 1800	30	21	14.0
1800 – 1900	30	21	15.0
1900 – 2000	31	22	15.0

Unit: μm

3.5.15.2 Accuracy – height and width

Height tolerance of H

Permissible absolute dimension variance of height H, measured between centre of screw-on surface C and underside of rail A, with block in any position on the rail.

Height variance of H

Permissible variance of height H between several blocks on a rail, measured in the same rail position

Width tolerance of N

Permissible absolute dimension variance of width N, measured between centre of screw-on surfaces D and B, with block in any position on the rail.

Width variance of N

Permissible variance of width N between several blocks on a rail, measured in the same rail position.

Table 3.92 Height and width tolerances

Series/size	Accuracy class	Height tolerance of H	Width tolerance of N	Height variance of H	Width variance of N
MG_05 – MG_15	C (Normal)	± 0.04	± 0.04	0.03	0.3
	H (High)	± 0.02	± 0.025	0.015	0.02
	P (Precision)	± 0.01	± 0.015	0.007	0.01

Unit: mm

3.5.15.3 Permissible mounting surface tolerances

Once the requirements relating to the accuracy of the mounting surfaces are met, the good accuracy, rigidity and lifetime of the MG series linear guideways are achieved.

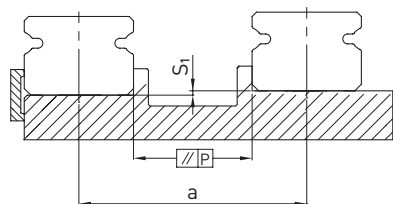

Tolerance for the parallelism of the reference surface (P):

Table 3.93 Maximum tolerance for parallelism (P)

Series/size	Preload class		
	ZF	Z0	Z1
MG_05	2	2	2
MG_07	3	3	3
MG_09	4	4	3
MG_12	9	9	5
MG_15	10	10	6

Unit: μm

Tolerance for the height of the reference surface (S_1):

F 3.17 $S_1 = a \times K$

S_1 Max. height tolerance [mm]
 a Distance between rails [mm]
 K Coefficient of the height tolerance

Table 3.94 Maximum tolerance for height of reference surface (S_1)

Series/size	Preload class		
	ZF	Z0	Z1
MG_05	0.4×10^{-4}	0.4×10^{-4}	0.04×10^{-4}
MG_07	0.5×10^{-4}	0.5×10^{-4}	0.06×10^{-4}
MG_09	0.7×10^{-4}	0.7×10^{-4}	0.12×10^{-4}
MG_12	1.0×10^{-4}	1.0×10^{-4}	0.24×10^{-4}
MG_15	1.2×10^{-4}	1.2×10^{-4}	0.40×10^{-4}

Table 3.95 Requirements for the mounting surface

Series/size	Required evenness of the mounting surface
MG_05	0.015/200
MG_07	0.025/200
MG_09	0.035/200
MG_12	0.050/200
MG_15	0.060/200

Note: The values in the table are applicable to the preload classes ZF and Z0. For Z1 or if more than one rail is to be mounted on the same surface, the table values must be at least halved.

Linear guideways

MG series

3.5.16 Shoulder heights and fillets

Imprecise shoulder heights and fillets of mounting surfaces compromise precision and may lead to conflicts with the block or rail profiles. The following shoulder heights and edge profiles must be observed in order to avoid assembly problems.

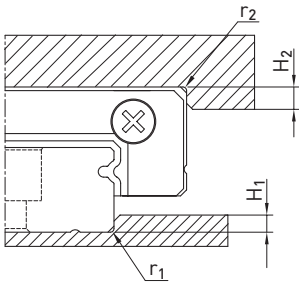

Table 3.96 Shoulder heights and fillets

Series/size	Max. edge radius r_1	Max. edge radius r_2	Shoulder height of H_1	Shoulder height of H_2
MGN05	0.1	0.2	1.2	2
MGN07	0.2	0.2	1.2	3
MGN09	0.2	0.3	1.7	3
MGN12	0.3	0.4	1.7	4
MGN15	0.5	0.5	2.5	5
MGW05	0.1	0.2	1.2	2
MGW07	0.2	0.2	1.7	3
MGW09	0.3	0.3	2.5	3
MGW12	0.4	0.4	3.0	4
MGW15	0.4	0.8	3.0	5

Unit: mm

3.6 RG and QR series

3.6.1 Properties of the linear guideways, series RG and QR

The HIWIN linear guideways of the RG series use rollers rather than balls as rolling elements. The RG series provides extremely good rigidity and very good loading capacity. It is designed with a 45° contact angle. Its linear contact surface greatly reduces deformation from the loading produced and therefore ensures very good rigidity and loading capacity in all 4 loading directions. The linear guides of the RG series are therefore ideal for use in high-precision manufacturing.

The models of the QR series with SynchMotion™ technology offer all the positive properties of the standard series RG. Controlled movement of the rollers at a defined distance also results in improved synchronous performance, higher reliable travel speeds, extended lubrication intervals and less running noise. Since the installation dimensions of the QR blocks are identical to those of the RG blocks, they are also fitted on the RGR standard rail and can therefore be interchanged with ease. For more information, refer to [Page 24](#).

3.6.2 Design of the RG/QR series

- 4-row recirculation roller bearing guide
- 45° contact angle
- Various sealing variants depending on the field of application
- 6 options for connecting grease nipple and lubrication adapter
- SynchMotion™ technology (QR series)

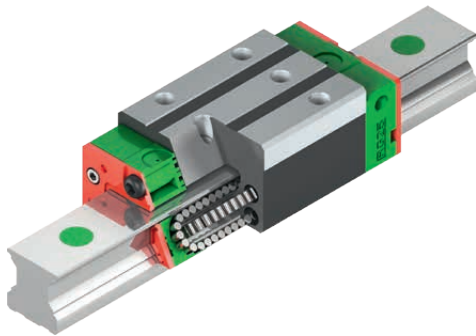

Design of the RG series

Advantages:

- Zero play
- Interchangeable
- Very high load ratings
- Very high rigidity
- Low displacement forces even with high preload

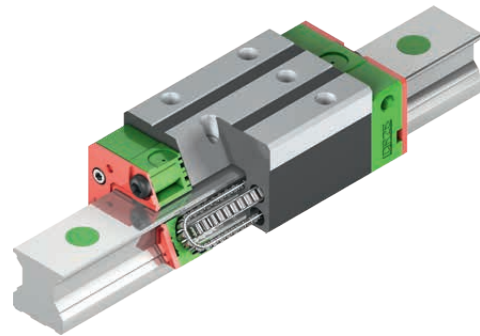

Design of the QR series

Additional advantages of QR series:

- Improved synchronous performance
- Optimized for higher travel speeds
- Extended lubrication intervals
- Less running noise
- Higher dynamic load capacities

3.6.3 Order codes for the RG/QR series

For RG/QR linear guideways, a distinction is made between fully assembled and unmounted models. The dimensions of both models are the same. The main difference is that the block and rail in unmounted models can be freely interchanged. The order codes of the series include the dimensions, model, accuracy class, preload etc.

Linear guideways

RG and QR series

Order code for linear guideway (fully assembled)

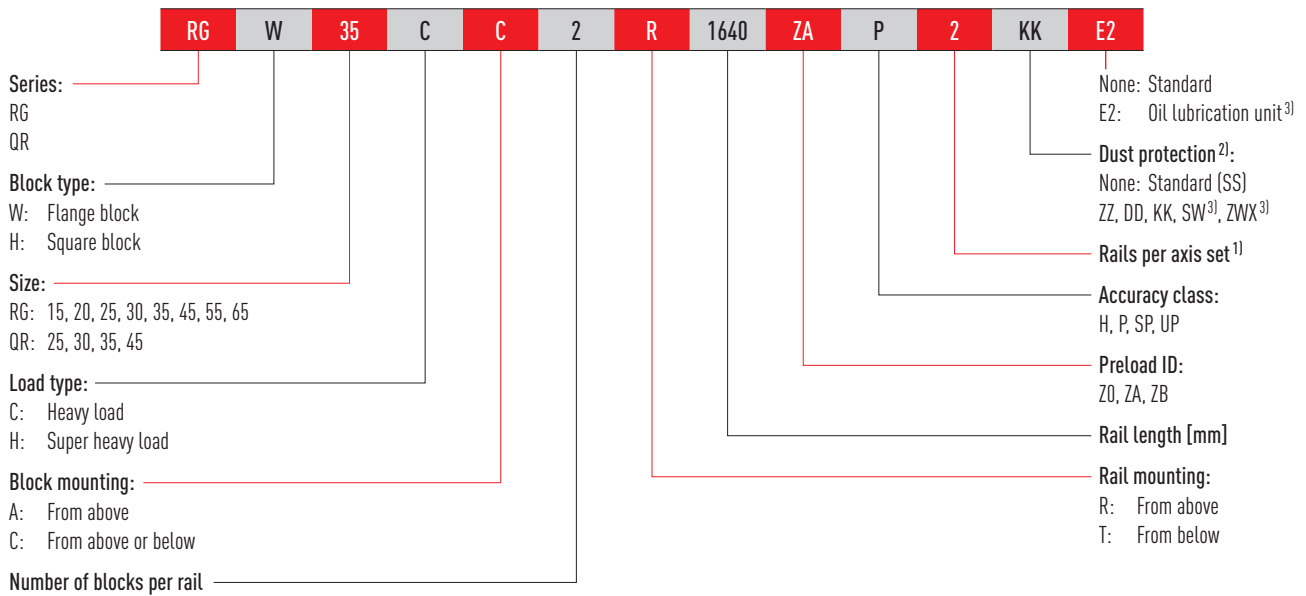

Order code for block (unmounted)

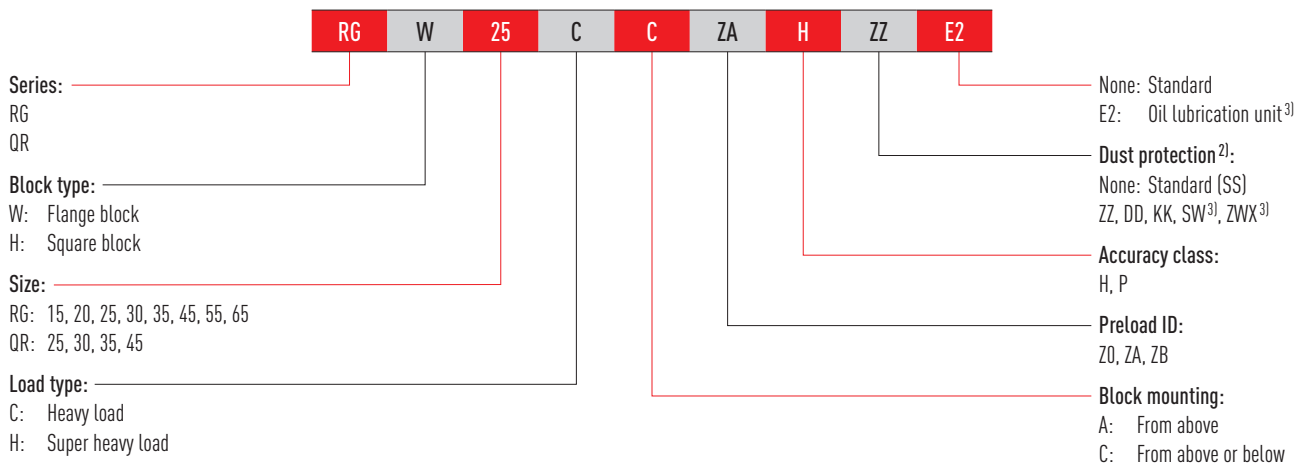

Order code for rail (unmounted)

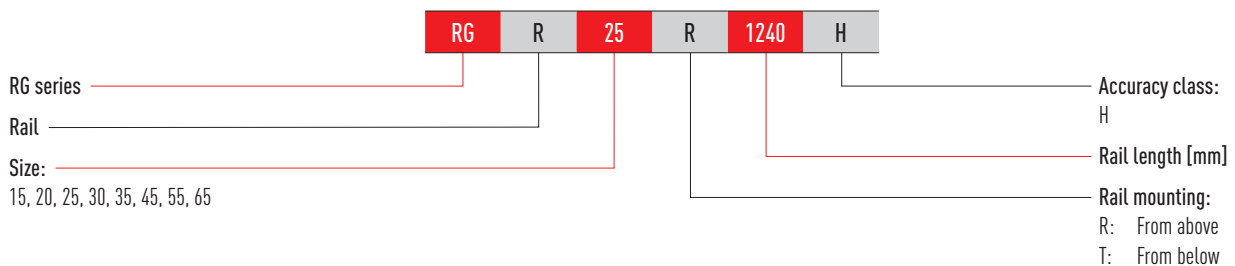

Note:

¹⁾ The figure 2 is also a quantity, i.e. one item of the above-mentioned article consists of a pair of rails. No number is specified for individual rails.

By default multi-part rails are delivered with staggered butt joints.

²⁾ You will find an overview of the individual sealing systems on [Page 22](#)

³⁾ Only available for RG

3.6.4 Block types

HIWIN provides square and flange blocks for the linear guideways. Given their low height and large mounting surface, flange blocks are suited to large loads.

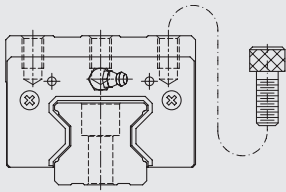
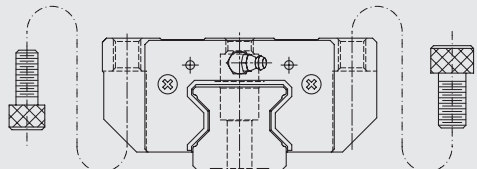
Type	Series/size	Structure	Height [mm]	Typical application
Square type	RGH-CA RGH-HA		28 – 90	<ul style="list-style-type: none"> ○ Automation technology ○ Transport technology ○ CNC machining centres ○ High-performance cutting machines ○ CNC grinding machines ○ Injection moulding machines ○ Portal milling machines
Flange type	RGW-CC RGW-HC		24 – 90	<ul style="list-style-type: none"> ○ Machines and systems requiring high rigidity ○ Machines and systems requiring high load rating ○ Spark erosion machines

3.6.5 Rail types

In addition to rails with standard fastening from above, HIWIN also provides rails for fastening from below.

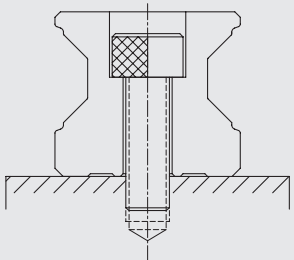
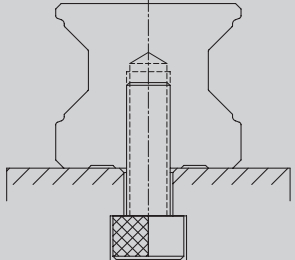
Fastening from above	Fastening from below
	
RGR_R	RGR_T

Linear guideways

RG and QR series

3.6.6 Preload

Definition

Every rail type can be preloaded based on the size of the balls. The curve shows that the rigidity doubles at higher preload. The RG/QR series offers three standard preload classes for various applications and conditions.

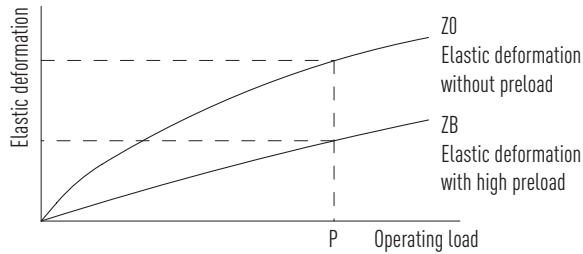

Preload ID

Table 3.99 Preload ID			
ID	Preload		Application
Z0	Light preload	0.02 – 0.04 C_{dyn}	Constant load direction, little impact, low precision required
ZA	Medium preload	0.07 – 0.09 C_{dyn}	High precision needed
ZB	High preload	0.12 – 0.14 C_{dyn}	Very high rigidity required, with vibration and impact

The diagram shows the relationship between rigidity, frictional resistance and nominal lifetime. For smaller models, a preload of no more than ZA is recommended to avoid the lifetime being shortened as a result of preload.

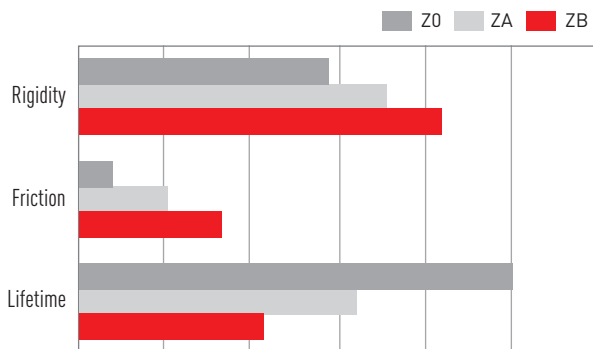

3.6.7 Load ratings and torques

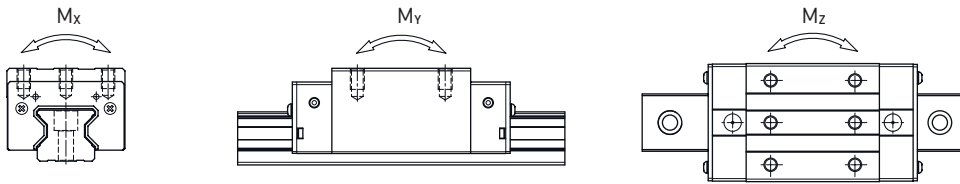

Table 3.100 Load ratings and torques for series RG/QR

Series/size	Dynamic load rating C_{dyn} [N] ¹⁾	Static load rating C_0 [N]	Dynamic moment [Nm]			Static moment [Nm]		
			M_x	M_y	M_z	M_{0x}	M_{0y}	M_{0z}
RG_15C	11,300	24,000	147	82	82	311	173	173
RG_20C	21,300	46,700	296	210	210	647	460	460
RG_20H	26,900	63,000	373	358	358	872	837	837
RG_25C	27,700	57,100	367	293	293	758	605	605
QR_25C	38,500	54,400	511	444	444	722	627	627
RG_25H	33,900	73,400	450	457	457	975	991	991
QR_25H	44,700	65,300	594	621	621	867	907	907
RG_30C	39,100	82,100	688	504	504	1,445	1,060	1,060
QR_30C	51,500	73,000	906	667	667	1,284	945	945
RG_30H	48,100	105,000	845	784	784	1,846	1,712	1,712
QR_30H	64,700	95,800	1,138	1,101	1,101	1,685	1,630	1,630
RG_35C	57,900	105,200	1,194	792	792	2,170	1,440	1,440
QR_35C	77,000	94,700	1,590	1,083	1,083	1,955	1,331	1,331
RG_35H	73,100	142,000	1,508	1,338	1,338	2,930	2,600	2,600
QR_35H	95,700	126,300	1,975	1,770	1,770	2,606	2,335	2,335
RG_45C	92,600	178,800	2,340	1,579	1,579	4,520	3,050	3,050
QR_45C	123,200	156,400	3,119	2,101	2,101	3,959	2,666	2,666
RG_45H	116,000	230,900	3,180	2,748	2,748	6,330	5,470	5,470
QR_45H	150,800	208,600	3,816	3,394	3,394	5,278	4,694	4,694
RG_55C	130,500	252,000	4,148	2,796	2,796	8,010	5,400	5,400
RG_55H	167,800	348,000	5,376	4,942	4,942	11,150	10,250	10,250
RG_65C	213,000	411,600	8,383	5,997	5,997	16,200	11,590	11,590
RG_65H	275,300	572,700	10,839	10,657	10,657	22,550	22,170	22,170

¹⁾ Dynamic load rating for travel distance of 100,000 m

Linear guideways

RG and QR series

3.6.8 Rigidity

Rigidity depends on preload. Formula F 3.18 can be used to determine deformation depending on rigidity.

F 3.18

$$\delta = \frac{P}{k}$$

δ Deformation [μm]
 P Operating load [N]
 k Rigidity [N/ μm]

Table 3.101 Radial rigidity for series RG/QR

Load class	Series/ size	Rigidity depending on preload		
		Z0	ZA	ZB
Heavy load	RG_15C	482	504	520
	RG_20C	586	614	633
	RG_25C	682	717	740
	QR_25C	616	645	665
	RG_30C	809	849	876
	QR_30C	694	726	748
	RG_35C	954	1,002	1,035
	QR_35C	817	856	882
	RG_45C	1,433	1,505	1,554
	QR_45C	1,250	1,310	1,350
	RG_55C	1,515	1,591	1,643
	RG_65C	2,120	2,227	2,300
Super heavy load	RG_20H	786	823	848
	RG_25H	873	917	947
	QR_25H	730	770	790
	RG_30H	1,083	1,136	1,173
	QR_30H	910	950	980
	RG_35H	1,280	1,344	1,388
	QR_35H	1,090	1,140	1,170
	RG_45H	1,845	1,938	2,002
	QR_45H	1,590	1,660	1,720
	RG_55H	2,079	2,182	2,254
RG_65H	2,931	3,077	3,178	

Unit: N/ μm

3.6.9 Dimensions of the RG/QR blocks

3.6.9.1 RGH/QRH

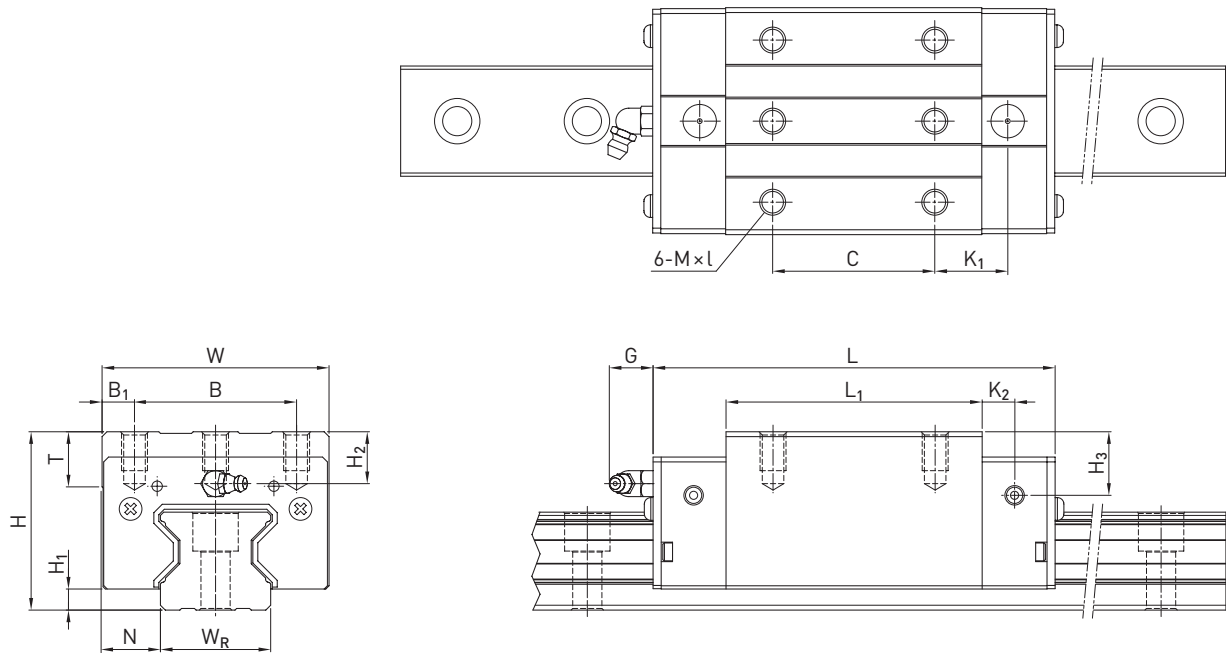

Table 3.102 Dimensions of the block

Series/ size	Installation dimensions [mm]			Dimensions of the block [mm]													Load ratings [N]		Weight [kg]
	H	H ₁	N	W	B	B ₁	C	L ₁	L	K ₁	K ₂	G	M × l	T	H ₂	H ₃	C _{dyn}	C ₀	
RGH15CA	28	4.0	9.5	34	26	4.0	26	45.0	68.0	13.40	4.70	5.3	M4 × 8	6.0	7.6	10.1	11,300	24,000	0.20
RGH20CA	34	5.0	12.0	44	32	6.0	36	57.5	86.0	15.80	6.00	5.3	M5 × 8	8.0	8.3	8.3	21,300	46,700	0.40
RGH20HA								50	77.5	106.0							18.80	26,900	63,000
RGH25CA	40	5.5	12.5	48	35	6.5	35	64.5	97.9	20.75	7.25	12.0	M6 × 8	9.5	10.2	10.0	27,700	57,100	0.61
RGH25HA								50	81.0	114.4							21.50	33,900	73,400
QRH25CA	40	5.5	12.5	48	35	6.5	35	66.0	9.9	20.75	7.25	12.0	M6 × 8	9.5	10.2	10.0	38,500	54,400	0.60
QRH25HA								50	81.0	112.9							21.50	44,700	65,300
RGH30CA	45	6.0	16.0	60	40	10.0	40	71.0	109.8	23.50	8.00	12.0	M8 × 10	9.5	9.5	10.3	39,100	82,100	0.90
RGH30HA								60	93.0	131.8							24.50	48,100	105,000
QRH30CA	45	6.0	16.0	60	40	10.0	40	71.0	109.8	23.50	8.00	12.0	M8 × 10	9.5	9.5	10.3	51,500	73,000	0.89
QRH30HA								60	93.0	131.8							24.50	64,700	95,800
RGH35CA	55	6.5	18.0	70	50	10.0	50	79.0	124.0	22.50	10.00	12.0	M8 × 12	12.0	16.0	19.6	57,900	105,200	1.57
RGH35HA								72	106.5	151.5							25.25	73,100	142,000
QRH35CA	55	6.5	18.0	70	50	10.0	50	79.0	124.0	22.50	10.00	12.0	M8 × 12	12.0	16.0	19.6	77,000	94,700	1.56
QRH35HA								72	106.5	151.5							25.25	95,700	126,300
RGH45CA	70	8.0	20.5	86	60	13.0	60	106.0	153.2	31.00	10.00	12.9	M10 × 17	16.0	20.0	24.0	92,600	178,800	3.18
RGH45HA								80	139.8	187.0							37.90	116,000	230,900
QRH45CA	70	8.0	20.5	86	60	13.0	60	106.0	153.2	31.00	10.00	12.9	M10 × 17	16.0	20.0	24.0	123,200	156,400	3.16
QRH45HA								80	139.8	187.0							37.90	150,800	208,600
RGH55CA	80	10.0	23.5	100	75	12.5	75	125.5	183.7	37.75	12.50	12.9	M12 × 18	17.5	22.0	27.5	130,500	252,000	4.89
RGH55HA								95	173.8	232.0							51.90	167,800	348,000
RGH65CA	90	12.0	31.5	126	76	25.0	70	160.0	232.0	60.80	15.80	12.9	M16 × 20	25.0	15.0	15.0	213,000	411,600	8.89
RGH65HA								120	223.0	295.0							67.30	275,300	572,700

For dimensions of rail, see Page 111, for standard and optional lubrication adapter, see Page 128.

Linear guideways

RG and QR series

3.6.9.2 RGW/QRW

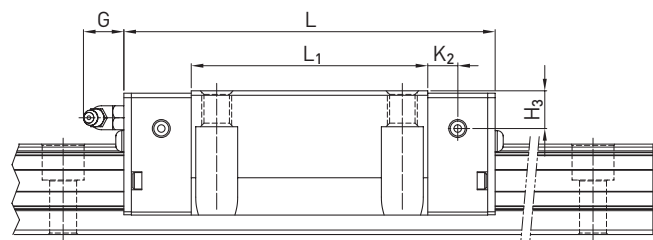
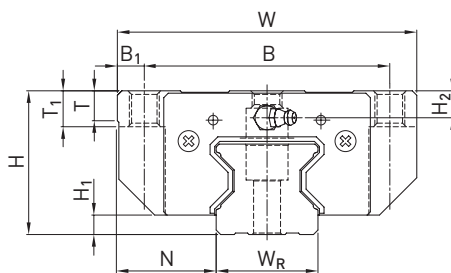
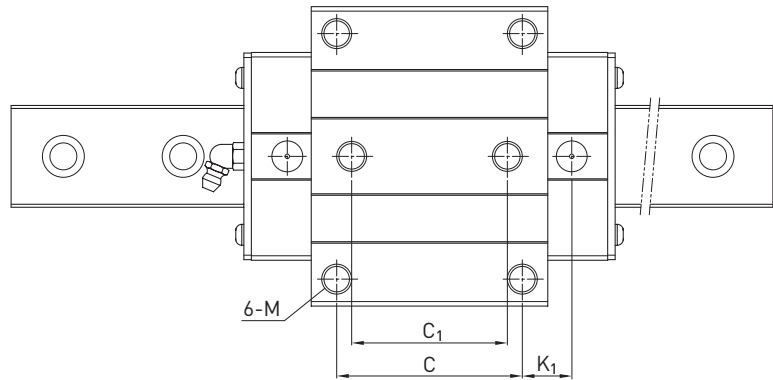

Table 3.103 Dimensions of the block

Series/ size	Installation dimensions [mm]			Dimensions of the block [mm]															Load ratings [N]		Weight [kg]
	H	H ₁	N	W	B	B ₁	C	C ₁	L ₁	L	K ₁	K ₂	G	M	T	T ₁	H ₂	H ₃	C _{dyn}	C ₀	
RGW15CC	24	4.0	16.0	47	38	4.5	30	26	45.0	68.0	11.40	4.70	5.3	M5	6.0	7	3.6	6.1	11,300	24,000	0.22
RGW20CC	30	5.0	21.5	63	53	5.0	40	35	57.5	86.0	13.80	6.00	5.3	M6	8.0	10	4.3	4.3	21,300	46,700	0.47
RGW20HC									77.5	106.0	23.80										
RGW25CC	36	5.5	23.5	70	57	6.5	45	40	64.5	97.9	15.75	7.25	12.0	M8	9.5	10	6.2	6.0	27,700	57,100	0.72
RGW25HC									81.0	114.4	24.00										
QRW25CC	36	5.5	23.5	70	57	6.5	45	40	66.0	97.9	15.75	7.25	12.0	M8	9.5	10	6.2	6.0	38,500	54,400	0.71
QRW25HC									81.0	112.9	24.00										
RGW30CC	42	6.0	31.0	90	72	9.0	52	44	71.0	109.8	17.50	8.00	12.0	M10	9.5	10	6.5	7.3	39,100	82,100	1.16
RGW30HC									93.0	131.8	28.50										
QRW30CC	42	6.0	31.0	90	72	9.0	52	44	71.0	109.8	17.50	8.00	12.0	M10	9.5	10	6.5	7.3	51,500	73,000	1.15
QRW30HC									93.0	131.8	28.50										
RGW35CC	48	6.5	33.0	100	82	9.0	62	52	79.0	124.0	16.50	10.00	12.0	M10	12.0	13	9.0	12.6	57,900	105,200	1.75
RGW35HC									106.5	151.5	30.25										
QRW35CC	48	6.5	33.0	100	82	9.0	62	52	79.0	124.0	16.50	10.00	12.0	M10	12.0	13	9.0	12.6	77,000	94,700	1.74
QRW35HC									106.5	151.5	30.25										
RGW45CC	60	8.0	37.5	120	100	10.0	80	60	106.0	153.2	21.00	10.00	12.9	M12	14.0	15	10.0	14.0	92,600	178,800	3.43
RGW45HC									139.8	187.0	37.90										
QRW45CC	60	8.0	37.5	120	100	10.0	80	60	106.0	153.2	21.00	10.00	12.9	M12	14.0	15	10.0	14.0	123,200	156,400	3.41
QRW45HC									139.8	187.0	37.90										
RGW55CC	70	10.0	43.5	140	116	12.0	95	70	125.5	183.7	27.75	12.50	12.9	M14	16.0	17	12.0	17.5	130,500	252,000	5.43
RGW55HC									173.8	232.0	51.90										
RGW65CC	90	12.0	53.5	170	142	14.0	110	82	160.0	232.0	40.80	15.80	12.9	M16	22.0	23	15.0	15.0	213,000	411,600	11.63
RGW65HC									223.0	295.0	72.30										

For dimensions of rail, see [Page 111](#), for standard and optional lubrication adapter, see [Page 128](#).

3.6.10 Dimensions of the RG rail

The RG rails are used for both the RG and QR blocks.

3.6.10.1 Dimensions of RGR_R

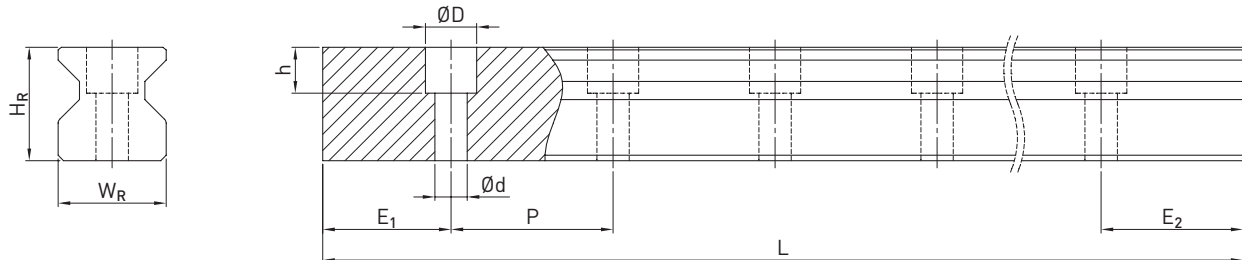

Table 3.104 Dimensions of rail RGR_R

Series/ size	Assembly screw for rail [mm]	Dimensions of rail [mm]						Max. length [mm]	Max. length $E_1 = E_2$ [mm]	Min. length [mm]	$E_{1/2}$ min [mm]	$E_{1/2}$ max [mm]	Weight [kg/m]
		W_R	H_R	D	h	d	P						
RGR15R	M4 × 20	15	16.5	7.5	5.7	4.5	30.0	4,000	3,960.0	72	6	24.0	1.70
RGR20R	M5 × 25	20	21.0	9.5	8.5	6.0	30.0	4,000	3,960.0	74	7	23.0	2.66
RGR25R	M6 × 30	23	23.6	11.0	9.0	7.0	30.0	4,000	3,960.0	76	8	22.0	3.08
RGR30R	M8 × 35	28	28.0	14.0	12.0	9.0	40.0	4,000	3,920.0	98	9	31.0	4.41
RGR35R	M8 × 35	34	30.2	14.0	12.0	9.0	40.0	4,000	3,920.0	98	9	31.0	6.06
RGR45R	M12 × 45	45	38.0	20.0	17.0	14.0	52.5	4,000/5,600 ¹⁾	3,937.5/5,437.5 ¹⁾	129	12	40.5	9.97
RGR55R	M14 × 55	53	44.0	23.0	20.0	16.0	60.0	4,000/5,600 ¹⁾	3,900.0/5,500 ¹⁾	148	14	46.0	13.98
RGR65R	M16 × 65	63	53.0	26.0	22.0	18.0	75.0	4,000/5,600 ¹⁾	3,900.0/5,500 ¹⁾	180	15	60.0	20.22

¹⁾ Optional version on request

3.6.10.2 Dimensions RGR_T (rail mounting from below)

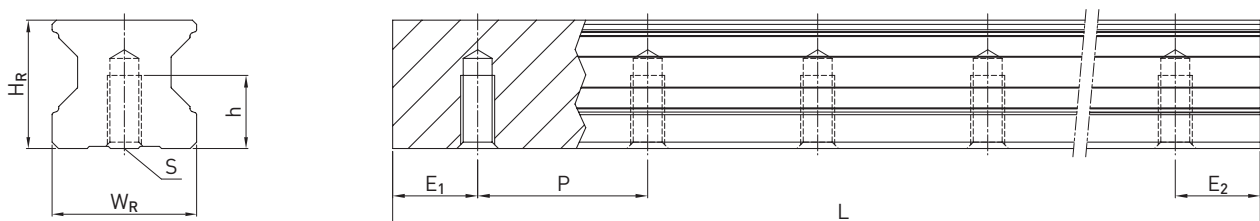

Table 3.105 Dimensions of rail RGR_T

Series/ size	Dimensions of rail [mm]					Max. length [mm]	Max. length $E_1 = E_2$ [mm]	Min. length [mm]	$E_{1/2}$ min [mm]	$E_{1/2}$ max [mm]	Weight [kg/m]
	W_R	H_R	S	h	P						
RGR15T	15	16.5	M5	8.0	30.0	4,000	3,960.0	72	6	24.0	1.86
RGR20T	20	21.0	M6	10.0	30.0	4,000	3,960.0	74	7	23.0	2.76
RGR25T	23	23.6	M6	12.0	30.0	4,000	3,960.0	76	8	22.0	3.36
RGR30T	28	28.0	M8	15.0	40.0	4,000	3,920.0	98	9	31.0	4.82
RGR35T	34	30.2	M8	17.0	40.0	4,000	3,920.0	98	9	31.0	6.48
RGR45T	45	38.0	M12	24.0	52.5	4,000	3,937.5	129	12	40.5	10.83
RGR55T	53	44.0	M14	24.0	60.0	4,000	3,900.0	148	14	46.0	15.15
RGR65T	63	53.0	M20 ¹⁾	30.0	75.0	4,000	3,900.0	180	15	60.0	21.24

¹⁾ Deviating from DIN 645

Note:

1. The tolerance for E is +0.5 to - 1 mm for standard rails and 0 to - 0.3 mm for joints.
2. If the $E_{1/2}$ dimensions are not indicated, the maximum possible number of mounting holes will be determined under consideration of $E_{1/2}$ min.
3. The rails are shortened to the required length. If the $E_{1/2}$ dimensions are not indicated, these will be carried out symmetrically.

Linear guideways

RG and QR series

3.6.10.3 Calculating the length of rails

HIWIN offers rails in customized lengths. To prevent the risk of the end of the rail becoming unstable, the value E must not exceed half of the distance between the mounting holes (P). At the same time, the value $E_{1/2}$ should be between $E_{1/2}$ min and $E_{1/2}$ max so that the mounting hole does not rupture.

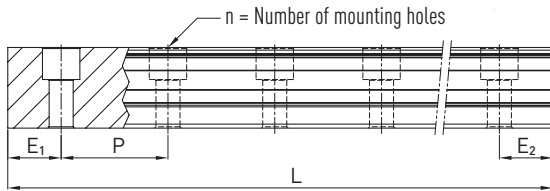

F 3.19

$$L = (n - 1) \times P + E_1 + E_2$$

- L Total length of the rail [mm]
- n Number of mounting holes
- P Distance between two mounting holes [mm]
- $E_{1/2}$ Distance from the middle of the last mounting hole to the end of the rail [mm]

3.6.10.4 Tightening torques for mounting bolts

Insufficient tightening of the mounting bolts strongly compromises the precision of the linear guideway. The following tightening torques are recommended for the relevant screw sizes.

Table 3.106 Tightening torques of the mounting bolts according to ISO 4762-12.9

Series/size	Screw size	Torque [Nm]	Series/size	Screw size	Torque [Nm]
RG_15	M4 × 20	4	RG/QR_35	M8 × 35	31
RG_20	M5 × 25	9	RG/QR_45	M12 × 45	120
RG/QR_25	M6 × 30	14	RG_55	M14 × 55	160
RG/QR_30	M8 × 35	31	RG_65	M16 × 65	200

3.6.10.5 Cover caps for mounting holes of rails

The cover caps are used to keep the mounting holes free of chips and dirt. The standard plastic caps are provided with each rail. Optional cover caps must be ordered separately.



Table 3.107 Cover caps for mounting holes of rails

Rail	Screw	Article number			Ø D [mm]	Height H [mm]
		Plastic (200 pcs.)	Brass	Steel		
RGR15R	M4	5-002218	5-001344	—	7.5	1.2
RGR20R	M5	5-002220	5-001350	5-001352	9.5	2.5
RGR25R	M6	5-002221	5-001355	5-001357	11.0	2.8
RGR30R	M8	5-002222	5-001360	5-001362	14.0	3.5
RGR35R	M8	5-002222	5-001360	5-001362	14.0	3.5
RGR45R	M12	5-002223	5-001324	5-001327	20.0	4.0
RGR55R	M14	5-002224	5-001330	5-001332	23.0	4.0
RGR65R	M16	5-002225	5-001335	5-001337	26.0	4.0

3.6.11 Sealing systems

Various sealing systems are available for HIWIN blocks. You will find an overview on [Page 22](#). The table below shows the total length of the blocks with the different sealing systems. Sealing systems suitable for these sizes are available.

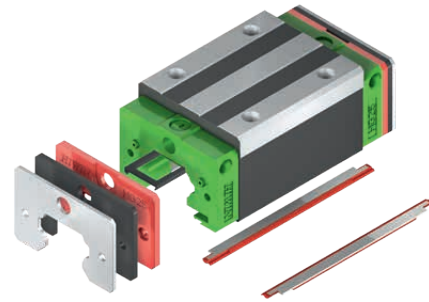

Table 3.108 Total length of block with different sealing systems

Series/ size	Total length L					
	SS	DD	ZZ	KK	SW	ZWX
RG_15C	68.0	72.4	70.0	74.4	—	—
RG_20C	86.0	90.4	88.0	92.4	—	—
RG_20H	106.0	110.4	108.0	112.4	—	—
RG_25C	97.9	102.3	99.9	104.3	—	—
QR_25C	97.7	102.3	99.9	104.3	—	—
RG_25H	114.4	118.8	116.4	120.8	—	—
QR_25H	112.9	117.3	114.9	119.3	—	—
RG_30C	109.8	114.6	112.8	117.6	—	—
QR_30C	109.8	114.6	112.8	117.6	—	—
RG_30H	131.8	136.6	134.8	139.6	—	—
QR_30H	131.8	136.6	134.8	139.6	—	—
RG_35C	124.0	129.0	127.0	132.0	—	—
QR_35C	124.0	129.0	127.0	132.0	—	—
RG_35H	151.5	156.5	154.5	159.5	—	—
QR_35H	151.5	156.5	154.5	159.5	—	—
RG_45C	153.2	160.4	156.2	163.4	156.5	166.2
QR_45C	153.2	160.4	156.2	163.4	—	—
RG_45H	187.0	194.2	190.0	197.2	190.3	200.0
QR_45H	187.0	194.2	190.0	197.2	—	—
RG_55C	183.7	190.9	186.7	193.9	186.9	198.3
RG_55H	232.0	239.2	235.0	242.2	235.2	246.6
RG_65C	232.0	240.8	235.0	243.8	235.2	245.3
RG_65H	295.0	303.8	298.0	306.8	298.2	308.3

Unit: mm

3.6.11.1 Designation of seal sets

The sealing sets are always supplied along with the assembly material and include the parts needed in addition to the standard seal.

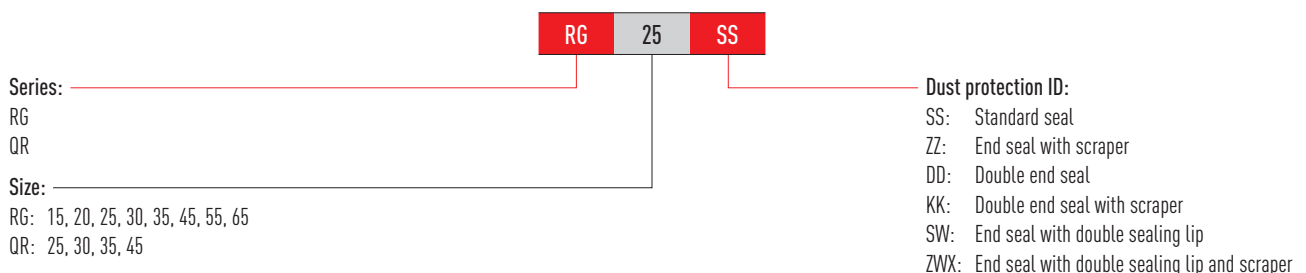

Linear guideways

RG and QR series

3.6.12 Friction

The table shows the maximum frictional resistance of the individual end seal. Depending on sealing setup (SS, ZZ, DD, KK), the value may have to be multiplied. The values indicated apply to blocks on uncoated rails. Higher friction forces occur on coated rails.

Table 3.109 Frictional resistance of the single-tipped seals

Series/size	Friction force [N]	Series/size	Friction force [N]
RG_15	2.0	RG/QR_35	3.5
RG_20	2.5	RG/QR_45	4.2
RG/QR_25	2.8	RG_55	5.1
RG/QR_30	3.3	RG_65	6.7

3.6.13 Lubrication unit E2

You will find more information about the lubrication unit in the general information in Section „2.6.3 Oil lubrication unit E2“ on Page 15.

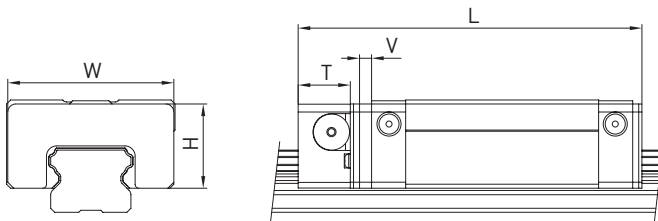

Table 3.110 Dimensions of block with lubrication unit E2

Model	Dimensions of the block [mm]								Oil quantity [cm ³]	Mileage ²⁾ [km]
	W	H	T	V	L _{SS} ¹⁾	L _{ZZ} ¹⁾	L _{DD} ¹⁾	L _{KK} ¹⁾		
RG_25C	46.8	29.2	13.5	3.5	114.9	116.9	119.3	121.3	5.0	6,000
RG_25H	46.8	29.2	13.5	3.5	131.4	133.4	135.8	137.8	5.0	6,000
RG_30C	58.8	34.9	13.5	3.5	126.8	129.8	131.6	134.6	7.5	8,000
RG_30H	58.8	34.9	13.5	3.5	148.8	151.8	153.6	156.6	7.5	8,000
RG_35C	68.8	40.3	13.5	3.5	141.0	144.0	146.0	149.0	10.7	10,000
RG_35H	68.8	40.3	13.5	3.5	168.5	171.5	173.5	176.5	10.7	10,000
RG_45C	83.8	50.2	16.0	4.5	173.7	176.7	180.9	183.9	18.5	20,000
RG_45H	83.8	50.2	16.0	4.5	207.5	210.5	214.7	217.7	18.5	20,000
RG_55C	97.6	58.4	16.0	4.5	204.2	207.2	211.4	214.4	26.5	30,000
RG_55H	97.6	58.4	16.0	4.5	252.5	255.5	259.7	262.7	26.5	30,000
RG_65C	121.7	76.1	16.0	4.5	252.5	255.5	261.3	264.3	50.5	40,000
RG_65H	121.7	76.1	16.0	4.5	315.5	318.5	324.3	327.3	50.5	40,000

¹⁾ Total length depending on selected dust protection. SS = Standard dust protection

²⁾ Mileage at which the oil tank level should be checked at the very latest.

3.6.14 Tolerances depending on accuracy class

The RG and QR series are available in four accuracy classes depending on parallelism between block and rail, height accuracy H and accuracy of width N. The choice of accuracy class is determined by the machine requirements.

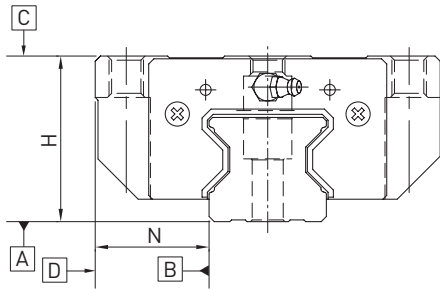

3.6.14.1 Parallelism

Parallelism of stop surfaces D and B of block and rail and parallelism of top of block C to mounting surface A of rail. Ideal linear guideway installation is required, as is a measurement in the centre of the block.

Table 3.111 Tolerance of parallelism between block and rail

Rail length [mm]	Accuracy class			
	H	P	SP	UP
- 100	7	3	2	2
100 - 200	9	4	2	2
200 - 300	10	5	3	2
300 - 500	12	6	3	2
500 - 700	13	7	4	2
700 - 900	15	8	5	3
900 - 1100	16	9	6	3
1100 - 1500	18	11	7	4
1500 - 1900	20	13	8	4
1900 - 2500	22	15	10	5
2500 - 3100	25	18	11	6
3100 - 3600	27	20	14	7
3600 - 4000	28	21	15	7

Unit: μm

Linear guideways

RG and QR series

3.6.14.2 Accuracy – height and width

Height tolerance of H

Permissible absolute dimension variance of height H, measured between centre of screw-on surface C and underside of rail A, with block in any position on the rail.

Height variance of H

Permissible variance of height H between several blocks on a rail, measured in the same rail position.

Width tolerance of N

Permissible absolute dimension variance of width N, measured between centre of screw-on surfaces D and B, with block in any position on the rail.

Width variance of N

Permissible variance of width N between several blocks on a rail, measured in the same rail position.

Series/size	Accuracy class	Height tolerance of H (T_H)	Width tolerance of N	Height variance of H	Width variance of N
RG_15, 20	H (High)	± 0.03	± 0.03	0.01	0.01
	P (Precision)	$0/-0.03^{1)}$ $\pm 0.015^{2)}$	$0/-0.03^{1)}$ $\pm 0.015^{2)}$	0.006	0.006
	SP (Super precision)	$0/-0.015$	$0/-0.015$	0.004	0.004
	UP (Ultra precision)	$0/-0.008$	$0/-0.008$	0.003	0.003
RG_25, 30, 35 QR_25, 30, 35	H (High)	± 0.04	± 0.04	0.015	0.015
	P (Precision)	$0/-0.04^{1)}$ $\pm 0.02^{2)}$	$0/-0.04^{1)}$ $\pm 0.02^{2)}$	0.007	0.007
	SP (Super precision)	$0/-0.02$	$0/-0.02$	0.005	0.005
	UP (Ultra precision)	$0/-0.01$	$0/-0.01$	0.003	0.003
RG_45, 55 QR_45	H (High)	± 0.05	± 0.05	0.015	0.02
	P (Precision)	$0/-0.05^{1)}$ $\pm 0.025^{2)}$	$0/-0.05^{1)}$ $\pm 0.025^{2)}$	0.007	0.01
	SP (Super precision)	$0/-0.03$	$0/-0.03$	0.005	0.007
	UP (Ultra precision)	$0/-0.02$	$0/-0.02$	0.003	0.005
RG_65	H (High)	± 0.07	± 0.07	0.02	0.025
	P (Precision)	$0/-0.07^{1)}$ $\pm 0.035^{2)}$	$0/-0.07^{1)}$ $\pm 0.035^{2)}$	0.01	0.015
	SP (Super precision)	$0/-0.05$	$0/-0.05$	0.007	0.01
	UP (Ultra precision)	$0/-0.03$	$0/-0.03$	0.005	0.007

Unit: mm

¹⁾ Fully assembled linear guideway

²⁾ Unmounted linear guideway

3.6.14.3 Permissible mounting surface tolerances

Once the requirements relating to the accuracy of the mounting surfaces are met, the good accuracy, rigidity and lifetime of the RG and QR series linear guideways are achieved.

Tolerance for the parallelism of the reference surface (P)

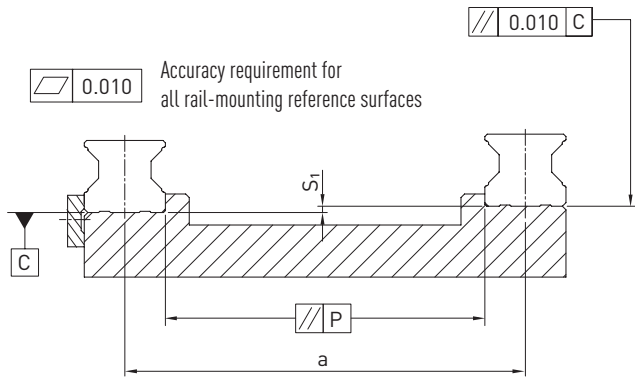

Table 3.113 Maximum tolerance for parallelism (P)

Series/size	Preload class		
	Z0	ZA	ZB
RG_15	5	3	3
RG_20	8	6	4
RG/QR_25	9	7	5
RG/QR_30	11	8	6
RG/QR_35	14	10	7
RG/QR_45	17	13	9
RG_55	21	14	11
RG_65	27	18	14

Unit: μm

Tolerance for the height of the reference surface (S_1)

F 3.20 $S_1 = a \times K - T_H$

- S_1 Max. height tolerance [mm]
- a Distance between rails [mm]
- K Coefficient of the height tolerance
- T_H Tolerance of height H acc. to [Table 3.112](#)

Table 3.114 Coefficient of height tolerance (K)

Series/size	Preload class		
	Z0	ZA	ZB
RG_15 – 65/QR_25 – 45	2.2×10^{-4}	1.7×10^{-4}	1.2×10^{-4}

Note: If $S_1 < 0$, select another tolerance class!

Linear guideways

RG and QR series

Height tolerance of the block mounting surface

- The height tolerance of the reference surface in the parallel use of two or more blocks (S_2)

 Accuracy requirement for all block-mounting reference surfaces

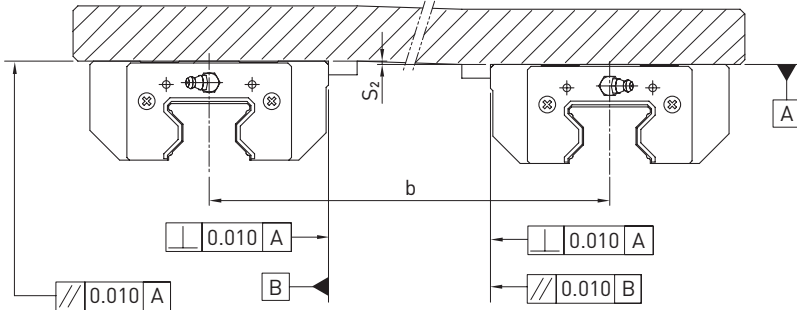

F 3.21 $S_2 = b \times 4.2 \times 10^{-5}$

S_2 Max. height tolerance [mm]
 b Distance between blocks [mm]

- The height tolerance of the reference surface in the parallel use of two or more blocks (S_3)

 Accuracy requirement for all block-mounting reference surfaces

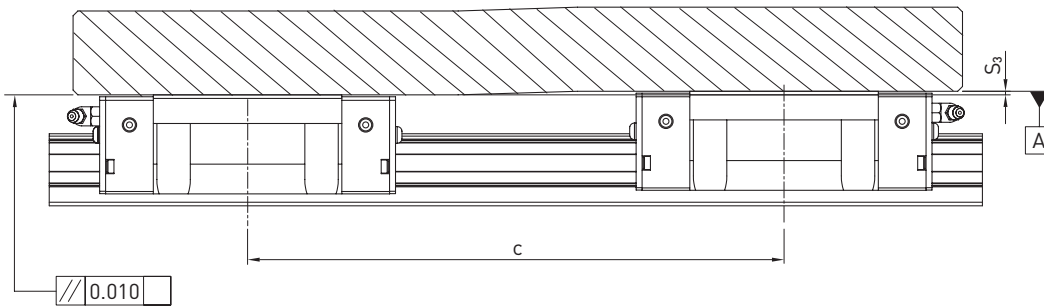

F 3.22 $S_3 = c \times 4.2 \times 10^{-5}$

S_3 Max. height tolerance [mm]
 c Distance between blocks [mm]

3.6.15 Shoulder heights and fillets

Imprecise shoulder heights and fillets of mounting surfaces compromise precision and may lead to conflicts with the block or rail profiles. The following shoulder heights and edge profiles must be observed in order to avoid assembly problems.

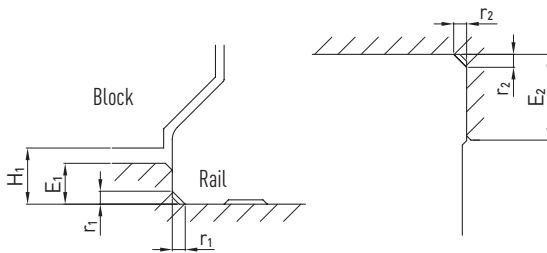

Table 3.115 Shoulder heights and fillets

Series/size	Max. edge radius r_1	Max. edge radius r_2	Shoulder height of reference edge of rail E_1	Shoulder height of reference edge of block E_2	Clearance under block H_1
RG_15	0.5	0.5	3.0	4.0	4.0
RG_20	0.5	0.5	3.5	5.0	5.0
RG/QR_25	1.0	1.0	5.0	5.0	5.5
RG/QR_30	1.0	1.0	5.0	5.0	6.0
RG/QR_35	1.0	1.0	6.0	6.0	6.5
RG/QR_45	1.0	1.0	7.0	8.0	8.0
RG_55	1.5	1.5	9.0	10.0	10.0
RG_65	1.5	1.5	10.0	10.0	12.0

Unit: mm

Linear guideways

PG series

3.7 PG series

3.7.1 Properties of the linear guideways, series PG

The HIWIN linear guideways of the PG series are a special type of the HG/QH/CG series with the integrated, magnetic distance measuring system MAGIC. The magnetic distance measuring systems of the HIWIN MAGIC series are optimised for measuring the distances travelled in linear movements and particularly on linear motor axes. The measuring system consists of a magnetic measuring gauge on a stainless steel carrier tape and a sensing unit. The robust housing with excellent electrical shielding and real-time signal output make the HIWIN MAGIC series the distance measuring system of choice for demanding applications.

In the PG series, the encoder is fitted directly on the HG/QH/CG series block. The magnetic tape is integrated in an additional groove in the HGR/CGR rail. The MAGIC distance measuring system is also available as a model not dependent on the rail. The customer can specify where the magnetic tape and stylus are positioned. For details, please refer to the catalogue "Linear Motors & Distance Measuring Systems".

3.7.2 Design of the PG series

- HG/QH/CG series block
- HG/CG series rail with additional groove for measuring scale
- Encoder can be fitted on HG_20, HG_25, QH_20, QH_25, CG_20 and CG_25 size blocks
- Assembly direction: Looking towards the reference edge of the block, the encoder is fitted on the left as standard. The encoder cable is also on the side of the reference edge

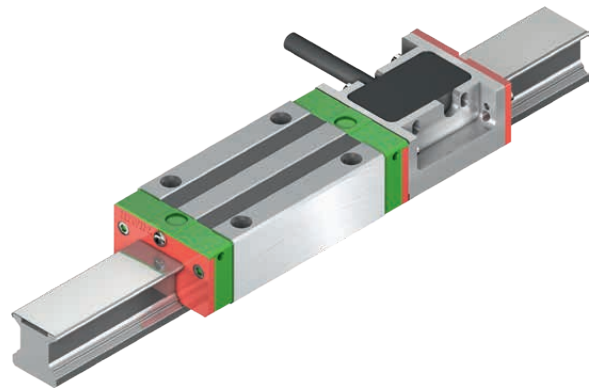
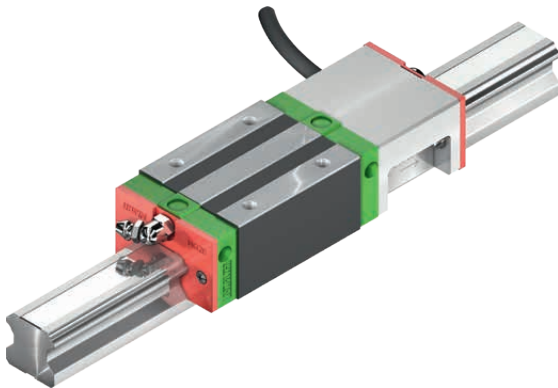

Characteristics:

- Zero contact measurement with 1 V_{pp} or digital output
- Digital resolution of 1 µm
- Encoder and housing are resistant to dust, humidity, oil and chips
- Encoder with metal housing and IP67 protection class
- Simple assembly
- Signal output in real time
- Special housing for EMC optimization

3.7.3 Order code for the PG series

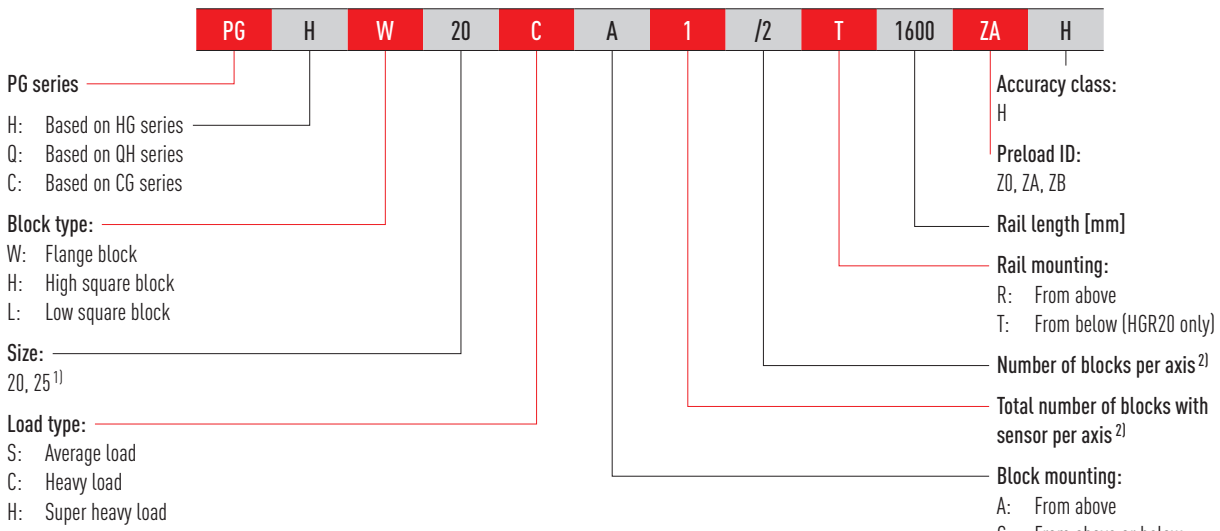

Continuation of order code for PG series

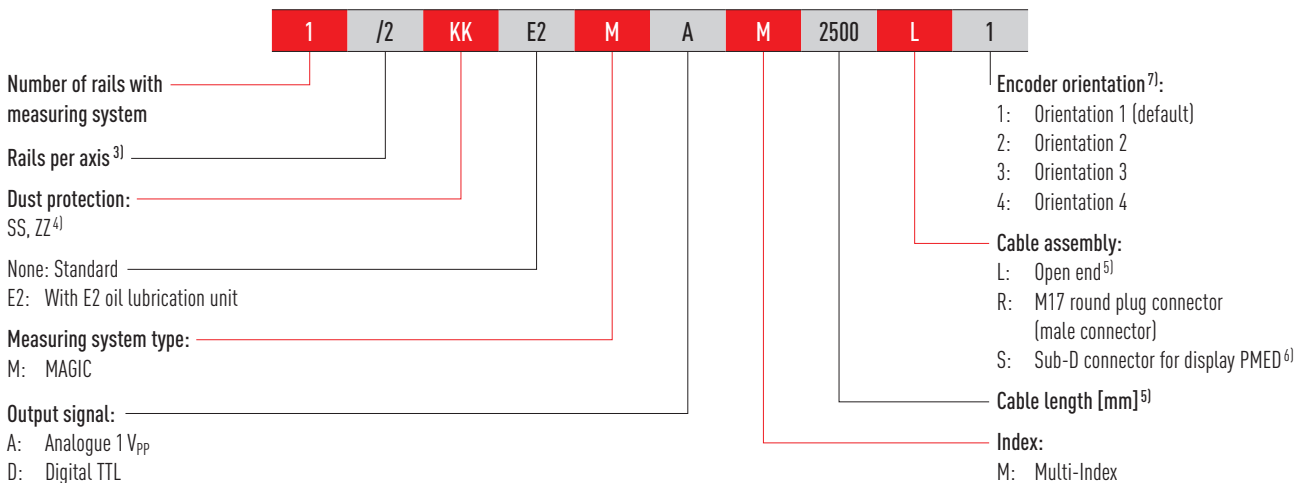

¹⁾ PGH, PGQ: not identical to the standard rail HGR25R without groove. Mounting screw M5 instead of M6

²⁾ In the PG series, the total number of blocks per axis is specified (all blocks of the ordered article)

³⁾ The figure 2 is also a quantity, i.e. one item of the above-mentioned article consists of a pair of rails
 No number is specified for individual rails. By default multi-part rails are delivered with staggered butt joints

⁴⁾ If nothing is specified, the block is supplied with standard dust protection (standard end seal and bottom seal)
 For an overview of the various sealing systems, see [Page 22](#).

⁵⁾ With open ends, the 1,000 cable length should be selected as standard (max. length PGH, PGQ: 5,000 mm; PGC: 1,000 mm)

⁶⁾ The display must be ordered separately.

⁷⁾ See Section [3.7.6](#)

Linear guideways

PG series

3.7.4 Dimensions of the PG blocks

The following figure shows a HGH20CA/HGH25CA block. It is also possible to use the modules with HG_20, HG_25, QH_20, QH_25, CG_20 and CG_25 block sizes. The overall dimensions then change accordingly. The dimensions of all block sizes are shown in [Table 3.116](#).

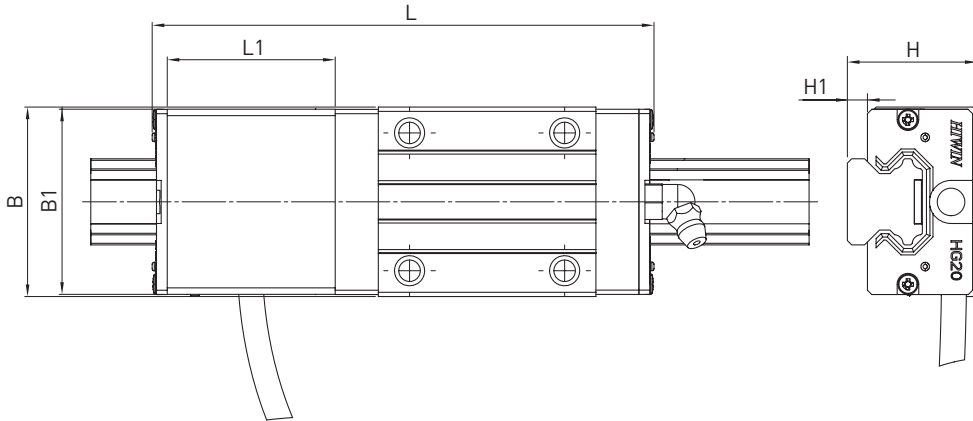

Table 3.116 Dimensions of the block including MAGIC-PG housing

Series/size	L [mm]	L1 [mm]	B [mm]	B1 [mm]	H [mm]	H1 [mm]
HG_20C	118.0	41.5	44	43.0	30	4.6
HG_20H	132.7	41.5	44	43.0	30	4.6
HG_25C	124.5	41.5	48	46.4	40	5.5
HG_25H	145.1	41.5	48	46.4	40	5.5
QH_20C	117.2	41.5	44	43.0	30	4.6
QH_20H	131.9	41.5	44	43.0	30	4.6
QH_25C	123.9	41.5	48	46.4	40	5.5
QH_25H	144.5	41.5	48	46.4	40	5.5
CG_20C	121.4	44.0	44	43.0	30	4.6
CG_20H	137.4	44.0	44	43.0	30	4.6
CG_25C	130.5	44.0	48	47.0	40	6.1
CG_25H	147.9	44.0	48	47.0	40	6.1

3.7.5 Dimensions of the PG rails

3.7.5.1 Rail with groove, mounting from above (series HG/QH)

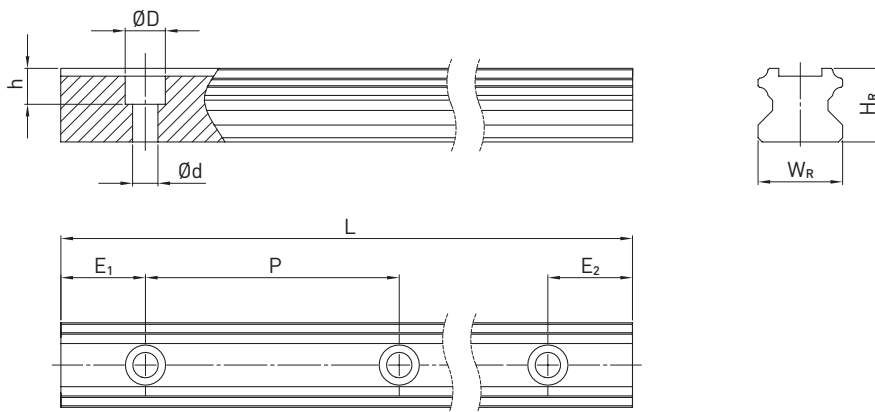

Table 3.117 Dimensions of HGR_R G1

Series/ size	Dimensions of rail [mm]						Max. length [mm]	Max. length $E_1 = E_2$ [mm]	$E_{1/2}$ min [mm]	$E_{1/2}$ max [mm]	Weight [kg/m]
	W_R	H_R	D	h	d	P					
HGR20R G1	20	17.5	9.5	8.5	6.0	60	4,000	3,900	7	53	2.05
HGR25R G1C	23	22.0	9.5	8.5	6.0	60	4,000	3,900	7	53	3.05

3.7.5.2 Rail with groove, mounting from below (series HG/QH)

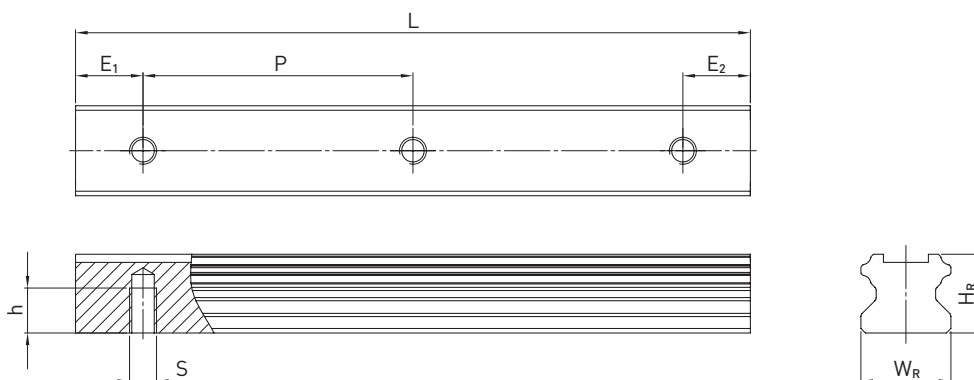

Table 3.118 Dimensions of HGR_T G1

Series/ size	Dimensions of rail [mm]					Max. length [mm]	Max. length $E_1 = E_2$ [mm]	$E_{1/2}$ min [mm]	$E_{1/2}$ max [mm]	Weight [kg/m]
	W_R	H_R	S	h	P					
HGR20T G1	20	17.5	M6	10	60	4,000	3,900	7	53	2.13

3.7.5.3 Rail with groove, mounting from above (series CG)

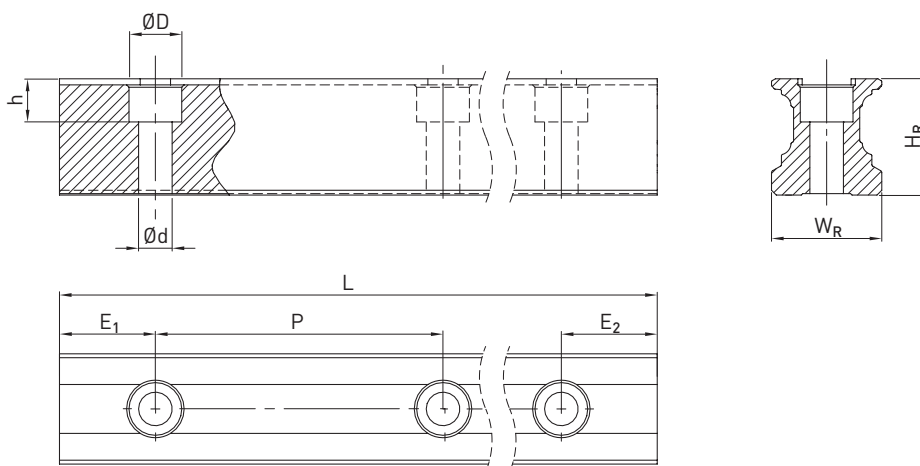

Table 3.119 Dimensions of CGR_R G1

Series/ size	Dimensions of rail [mm]						Max. length [mm]	Max. length $E_1 = E_2$ [mm]	$E_{1/2}$ min [mm]	$E_{1/2}$ max [mm]	Weight [kg/m]
	W_R	H_R	D	h	d	P					
CGR20R G1	20	20.55	9.5	8.5	6.0	60	4,000	3,900	7	53	2.05
CGR25R G1	23	24.25	11.0	9.0	7.0	60	4,000	3,900	8	52	3.05

Linear guideways

PG series

3.7.5.4 Tightening torques for mounting bolts

Insufficient tightening of the mounting bolts strongly compromises the precision of the linear guideway; the following tightening torques are therefore recommended for the relevant screw sizes.

Table 3.120 Tightening torques of the mounting bolts according to ISO 4762-12.9

Series/size	Screw size	Torque [Nm]	Series/size	Screw size	Torque [Nm]
HGR20R G1	M5 × 20	9	CGR20R G1	M5 × 25	9
HGR20T G1	M6	13	CGR25R G1	M6 × 30	13
HGR25R G1C	M5 × 20	9			

Note: The PGC version always requires the cover strip of the rail to clamp the magnetic tape.

3.7.6 Orientation of the HIWIN MAGIC-PG encoder

According to the order code (section 3.7.3) the HIWIN MAGIC-PG encoder is available in the orientations 1 to 4. Without a statement about the required orientation the encoder is delivered by default (orientation 1).

For more than one block on a rail or on a rail pair, the encoder is assembled on block 1, rail 1, as shown below. If a non-standard orientation is needed, this has to be defined in the MAGIC-PG project planning sheet (www.hiwin.de).

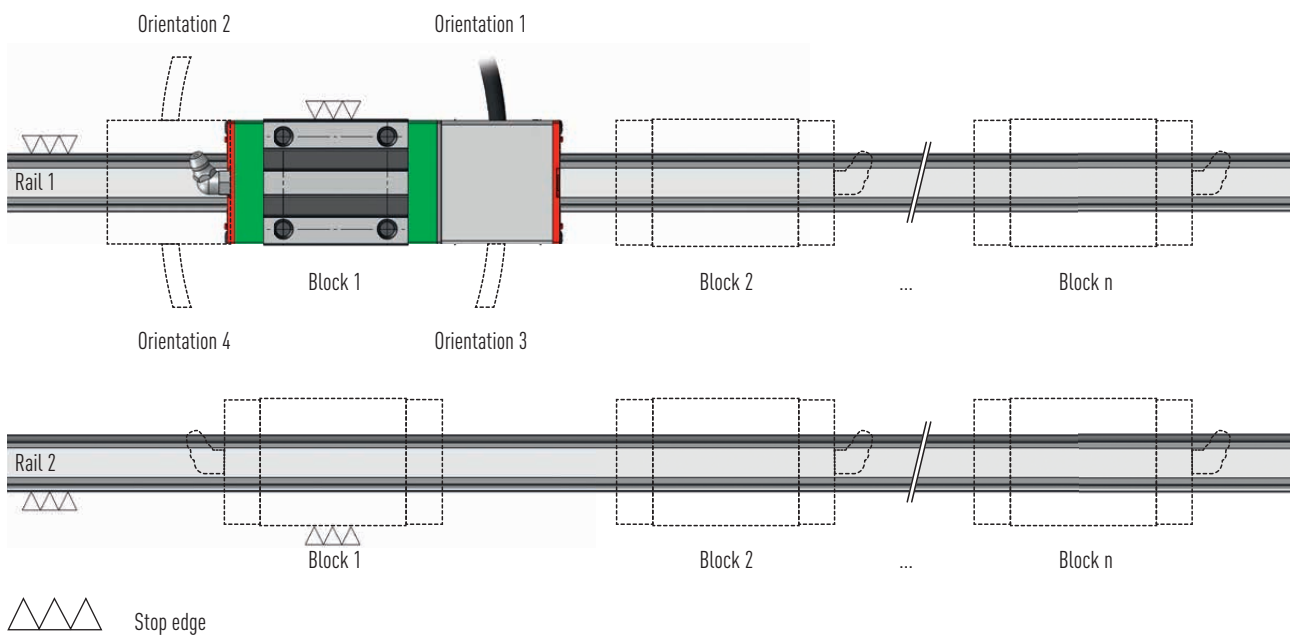

3.7.7 Specifications of the distance measuring system HIWIN MAGIC and HIWIN MAGIC-PG

Table 3.121 Electrical and mechanical properties of HIWIN MAGIC and HIWIN MAGIC-PG

	1 V _{PP} (analogue)	TTL (digital)
Electrical properties		
Output signal specification	sin/cos, 1 V _{PP} (0.85 V _{PP} – 1.2 V _{PP})	Quadrature signal acc. to RS-422
Resolution	Infinite, signal period 1 mm	1 μm
Repeatability bidirectional	0.003 mm	0.002 mm
Absolute accuracy	± 20 μm/m	
Reference signal ¹⁾	Periodic index impulse at a distance of 1 mm	
Phase angle	90° ± 0.1° el	90°
DC component	2.5 V ± 0.3 V	—
Distortion factor	Typ. < 0.1 %	—
Operating voltage	5 V ± 5 %	
Power consumption	Typ. 35 mA, max. 70 mA	Typ. 70 mA, max. 120 mA
Max. measurement speed	10 m/s	5 m/s
EMC class	3, according to IEC 801	
Mechanical properties		
Housing material	Aluminium alloy, encoder bottom made of stainless steel	
Cable length ²⁾	PGH/PGQ: 5,000 mm; PGC: 1,000 mm	
Min. bending radius cable	40 mm	
Protection class	IP67	
Operating temperature	0 °C to +50 °C	
Weight of MAGIC encoder	80 g	
Weight of MAGIC-PG encoder	80 g	
MAGIC-PG suitable for blocks	HG_20, HG_25, QH_20, QH_25, CG_20, CG_25	

¹⁾ Can be used e.g. with reference switch

²⁾ For the use in energy chains we recommend our pre-assembled encoder cable with a pre-mounted round connector M17 (coupling, female) on one side, which matches the optional round plug connector M17 (male) of the encoder. For details, please contact your HIWIN technician.

Table 3.122 Properties of the magnetic scale

Properties	MAGIC-PG	MAGIC
Accuracy class ¹⁾	± 20 μm/m	
Linear expansion coefficient	11.5 × 10 ⁻⁶ m/K	
Period	1 mm	
Thickness magnetic scale	1.70 ± 0.10 mm	
Thickness magnetic scale with stainless steel protective cover tape	—	1.85 ± 0.15 mm
Width	10.05 ± 0.10 mm	
Maximum length	24 m	
Magnetic remanence	> 240 mT	
Pole pitch (distance north/south pole)	1 mm	
Single reference marks	Optional	
Material	Elastomers, nitrile and EPDM	
Temperature range	0 °C to +50 °C	
Weight	70 g/m	

¹⁾ at 20 °C

Linear guideways

PG series

Separate magnetic scale (left) without protective cover tape and integrated into a profile rail (right) with stainless steel protective cover tape

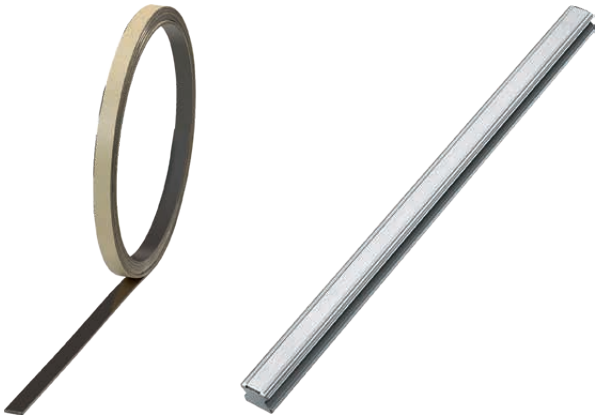

3.7.8 Connection for MAGIC distance measuring system

3.7.8.1 Cable assignment (analogue and digital variant)

A high-quality, 8-core cable, each V1+, V1-, V2+, V2- and V0+, V0- (or A, \bar{A} , B, \bar{B} and Z, \bar{Z} for the digital variant), is used twisted in pairs.

In energy chains, we generally recommend our pre-assembled extension cables, which

are designed especially for such use. The extension cables are supplied with a M17 round plug connector on one end (female coupling) or customized.

3.7.8.2 MAGIC measuring system formats and outputs (analogue)

Signal format of sin/cos 1 V_{PP} output

The electrical signals after the differential input of the subsequent electronics. The HIWIN MAGIC sin/cos 1 V_{PP} interface is strictly oriented towards the Siemens

specification. The period length of the sine output signal is 1 mm. The period length of the reference signal is 1 mm.

Electrical signals after the differential input of the downstream electronic components (analogue version)

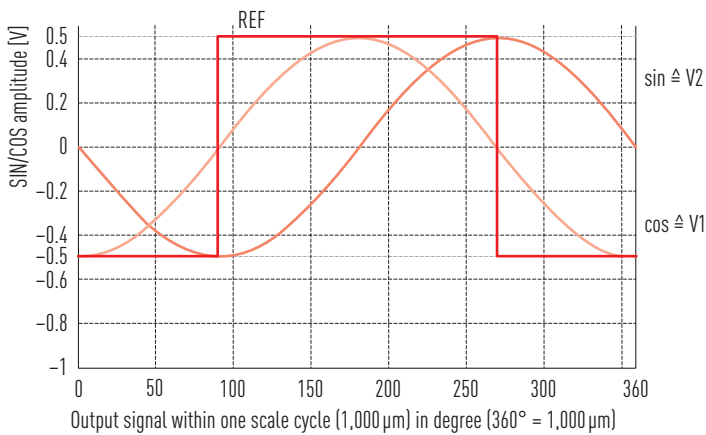

Recommended subsequent electronics circuit for sine/cosine 1 V_{PP} output

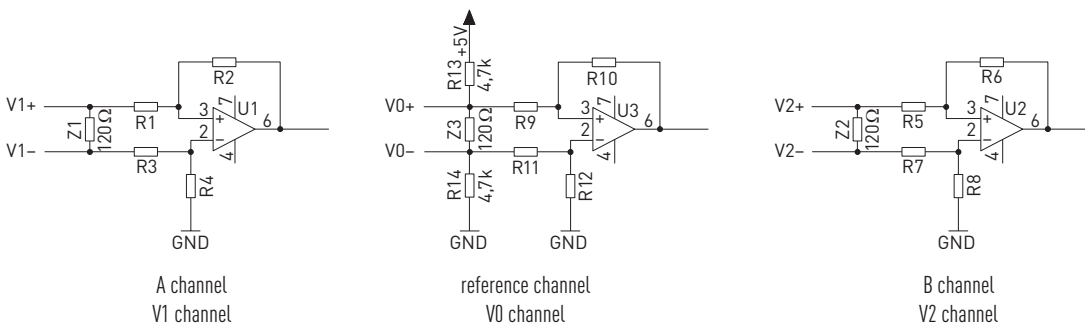

TTL-output (digital)

The signals on A and B channels have a 90° phase shift (according to RS-422 specification in DIN 66259). Recommended terminal resistance $Z = 120 \Omega$. Output signals: A, \bar{A} , B, \bar{B} and Z, \bar{Z} . Individual reference pulse (optional) and definition of a minimum pulse duration are possible as an option.

Signals of the MAGIC encoder (TTL version)

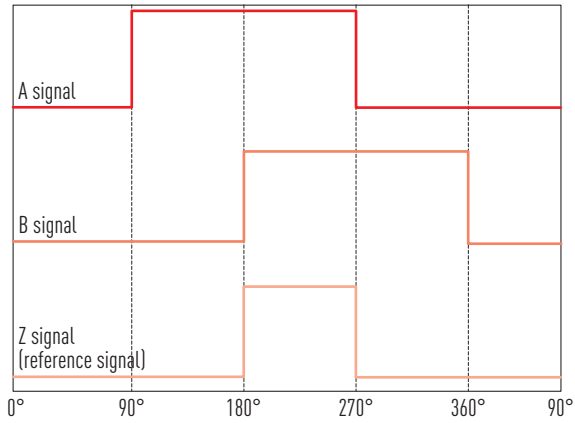

Recommended subsequent electronics circuit for TTL output

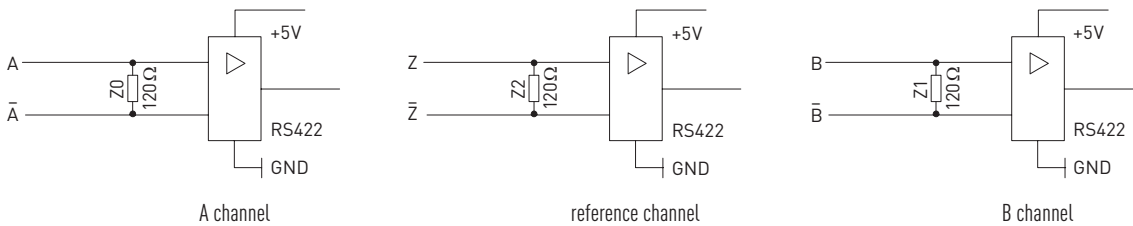

Linear guideways

Accessories

4. Accessories

4.1 Lubrication adapters

A grease nipple is attached to the front side of the block as standard **(1)**. The lubrication connection on the opposite side is sealed with a plug screw. Alternatively, lubrication can also be carried out through one of the four laterally provided connections on the recirculation unit **(2)** or from above **(3)**. Grease nipples, lubrication adapters or push-on connectors can be used for lubrication.

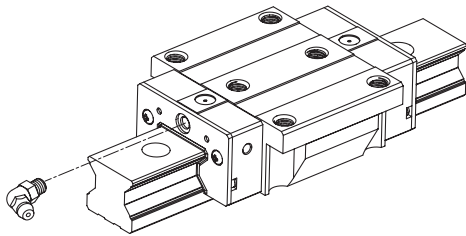

(1) Front side lubrication

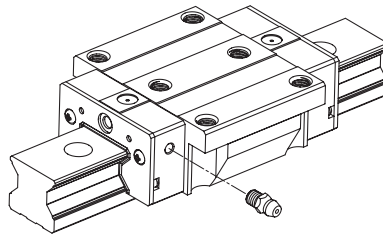

(2) Side lubrication

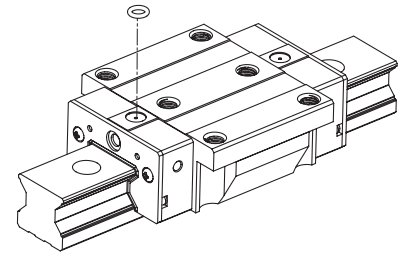

(3) Lubrication from above

Table 4.1 Overview block type/thread size

Block type	Thread size front/side
HG_15	M4
HG_20, HG_25, HG_30, HG_35	M6 × 0.75
HG_45, HG_55, HG_65	1/8 PT
QH_15	M4
QH_20, QH_25, QH_30, QH_35	M6 × 0.75
QH_45	1/8 PT
EG_15	M4
EG_20, EG_25, EG_30, EG_35	M6 × 0.75
QE_15	M4
QE_20, QE_25, QE_30, QE_35	M6 × 0.75
CG_15, CG_20	M3
CG_25, CG_30, CG_35, CG_45	M6 × 0.75
WE_17	M3
WE_21, WE_27, WE_35, QW_21, QW_27, QW_35	M6 × 0.75
WE_50	1/8 PT
MG_15	M3
RG_15, RG_20	M4
RG_25, RG_30, RG_35	M6 × 0.75
RG_45, RG_55, RG_65	1/8 PT
QR_25, QR_30, QR_35	M6 × 0.75
QR_45	1/8 PT

4.1.1 Grease nipples and lubrication fittings

Table 4.2 Grease nipples M3 × 0.5P





	
<p>Art. No.: 20-000275 (Standard)</p>	<p>Art. No.: 20-000370 (Option)</p>

Table 4.3 Grease nipples and lubrication fittings M4 × 0.7P

	
<p>LF-64 Art. No.: 20-000019</p>	
	
<p>Art. No.: 20-000272 (Standard)</p>	<p>Art. No.: 20-000325 (Option)</p>

The stated article numbers apply to the standard dust protection. Article numbers for optional dust protection available on request.

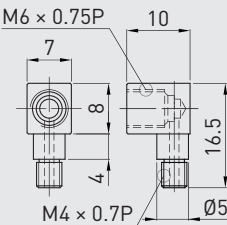
Linear guideways

Accessories

Table 4.4 Grease nipples and lubrication fittings M6 × 0.75P

<p>SF-76 Art. No.: 20-000006</p>	<p>LF-76 Art. No.: 20-000007</p>	<p>SF-86 Art. No.: 20-000008</p>	<p>LF-86 Art. No.: 20-000009</p>
<p>Art. No.: 20-000273 (Option)</p>	<p>Art. No.: 20-000283 (Option)</p>	<p>Art. No.: 20-000290 (Standard)</p>	

Table 4.5 Grease nipples and lubrication fittings 1/8 PT

<p>SF-78 Art. No.: 20-000010</p>	<p>LF-78 Art. No.: 20-000011</p>	<p>SF-88 Art. No.: 20-000012</p>	<p>LF-88 Art. No.: 20-000013</p>
<p>Art. No.: 20-000280 (Option)</p>	<p>Art. No.: 20-000292 (Standard)</p>		

The stated article numbers apply to the standard dust protection. Article numbers for optional dust protection available on request.

4.1.2 Push-in fittings

Table 4.6 Push-in fittings

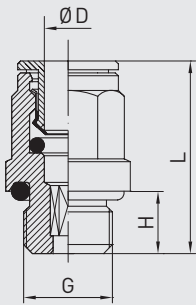
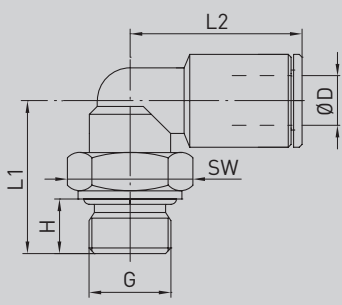
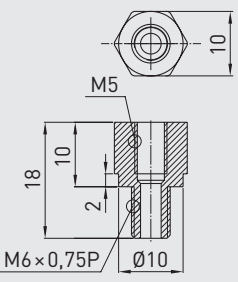
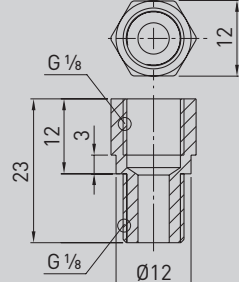
	
Straight push-in fitting	90° angled push-in fitting
	
Art. No.: 20-000416 – Adapter M5 ¹⁾	Art. No.: 20-000418 – Adapter G 1/8 ¹⁾

¹⁾ The adapters shown are needed for push-in fittings with threads M5 or G 1/8. Push-in fittings with thread M6 are screwed in the block without adapter.

Table 4.7 Dimensions of push-in fittings

Article number	G	Ø D	Shape	H	L	L1	L2	SW
20-000439	M5 × 0.8	4	Straight	4	20.5	—	—	—
20-000462	M5 × 0.8	6	Straight	4	22.5	—	—	—
20-000465	M5 × 0.8	4	Angled	4	—	14.5	18	9
20-000466	M5 × 0.8	6	Angled	4	—	14.5	21	9
8-12-0127	M6 × 0.75	4	Straight	5	23.5	—	—	—
20-000463	M6 × 0.75	6	Straight	4	22.5	—	—	—
8-12-0128	M6 × 0.75	4	Angled	5	—	15.5	18	9
8-12-0138	M6 × 0.75	6	Angled	5	—	15.5	21	9
8-12-0131	G 1/8	4	Straight	6	20.0	—	—	—
8-12-0136	G 1/8	6	Straight	6	24.0	—	—	—
8-12-0130	G 1/8	4	Angled	6	—	20.0	20	13
8-12-0137	G 1/8	6	Angled	6	—	20.0	21	13

The stated article numbers apply to the standard dust protection. Article numbers for optional dust protection available on request.

Linear guideways

Accessories

4.2 HIWIN grease guns and lubricants

Table 4.8 HIWIN grease guns

Article number	Grease gun	Lubrication adapter and set of nozzles	Direct filling	Cartridge
20-000352	●	—	●	70 g
20-000332	●	●	●	70 g
20-000353	●	—	●	400 g
20-000333	●	●	●	400 g
20-000358	—	●	—	—

Table 4.9 HIWIN greases

Grease type	Area of application	Article number	
		70 g cartridge	400 g cartridge
G01	Heavy-duty applications	20-000335	20-000336
G02	Clean room applications	20-000338	20-000339
G03	Clean room applications High speed	20-000341	20-000342
G04	High speed	20-000344	20-000345
G05	Standard grease	20-000347	20-000348

Table 4.10 HIWIN oils

Article number	Description	Scope of delivery	Comment
20-000350	SHC 636	1-litre bottle	Oil for filling the E2 lubrication tank

You will also find details about the HIWIN lubricants and lubrication of the linear guideways in the HIWIN assembly instructions “**Linear Guideways**” available from www.hiwin.de.

We live motion.



Linear Guideways



Ballscrews

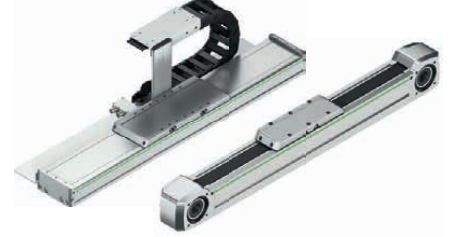

Linear Axes



Linear Axis Systems



Torque Motors



Robots



Linear Motor Components



Rotary Tables



Drives & Servo Motors

Germany

HIWIN GmbH
Brücklesbünd 1
D-77654 Offenburg
Phone +49 (0) 7 81 9 32 78 - 0
Fax +49 (0) 7 81 9 32 78 - 90
info@hiwin.de
www.hiwin.de

Taiwan

Headquarters
HIWIN Technologies Corp.
No. 7, Jingke Road
Taichung Precision Machinery Park
Taichung 40852, Taiwan
Phone +886-4-2359-4510
Fax +886-4-2359-4420
business@hiwin.tw
www.hiwin.tw

Taiwan

Headquarters
HIWIN Mikrosystem Corp.
No. 6, Jingke Central Road
Taichung Precision Machinery Park
Taichung 40852, Taiwan
Phone +886-4-2355-0110
Fax +886-4-2355-0123
business@hiwinmikro.tw
www.hiwinmikro.tw

France

HIWIN GmbH
4, Impasse Joffre
FR-67202 Wolfisheim
Phone +33 (0) 3 88 28 84 80
info@hiwin.de
www.hiwin.de/fr

Italy

HIWIN Srl
Via Pitagora 4
I-20861 Brugherio (MB)
Phone +39 039 287 61 68
Fax +39 039 287 43 73
info@hiwin.it
www.hiwin.it

Poland

HIWIN GmbH
ul. Putawska 405a
PL-02-801 Warszawa
Phone +48 22 544 07 07
Fax +48 22 544 07 08
info@hiwin.pl
www.hiwin.pl

Switzerland

HIWIN Schweiz GmbH
Eichwiesstrasse 20
CH-8645 Jona
Phone +41 (0) 55 225 00 25
Fax +41 (0) 55 225 00 20
info@hiwin.ch
www.hiwin.ch

Slovakia

HIWIN s.r.o., o.z.z.o.
Mládežnícka 2101
SK-01701 Považská Bystrica
Phone +421 424 43 47 77
Fax +421 424 26 23 06
info@hiwin.sk
www.hiwin.sk

Czech Republic

HIWIN s.r.o.
Medkova 888/11
CZ-62700 Brno
Phone +42 05 48 528 238
Fax +42 05 48 220 223
info@hiwin.cz
www.hiwin.cz

Netherlands

HIWIN GmbH
info@hiwin.nl
www.hiwin.nl

Austria

HIWIN GmbH
info@hiwin.at
www.hiwin.at

Slovenia

HIWIN GmbH
info@hiwin.si
www.hiwin.si

Hungary

HIWIN GmbH
info@hiwin.hu
www.hiwin.hu

China

HIWIN Corp.
www.hiwin.cn

Japan

HIWIN Corp.
mail@hiwin.co.jp
www.hiwin.co.jp

USA

HIWIN Corp.
info@hiwin.com
www.hiwin.com

Korea

HIWIN Corp.
www.hiwin.kr

Singapore

HIWIN Corp.
www.hiwin.sg