

Wire Race Bearings Slim Bearings Linear Systems

Product Catalogue

Standard program





Light Bearings for Innovation

From the inventor of Wire Race Bearings

In the patent specification dated 3 March 1934, Erich Franke defined his ground-breaking invention as follows: "ball bearing, characterized by the fact that the ball raceways for the balls consist of four open rings of steel wire, which are embedded directly in grooves of the two bodies supported by the bearing."

Customized solutions since 1934

Franke Wire Race Bearings were first used as extremely space-saving bearings for a complex optical device by the firm Zeiss. It marked the begin of our success story across all industries.



Franke around the world

One-stop service is among the fundamental principles we apply to our business. Franke has established representations and forged partnerships worldwide to deliver advice and all Franke products precisely where you need them.

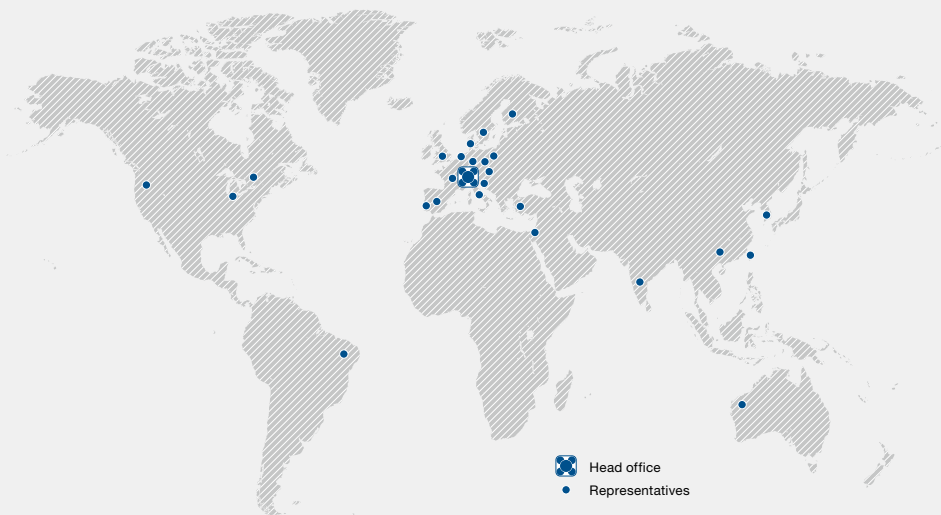

Wire Race Bearings
Structure and benefits



Bearing Elements

LEL
LER



Slim Bearings

LSA
LSB



Bearing Assemblies

LVA
LVB
LVC

LVD
LVE



Rotary systems

LTA
LTB



Accessories

Technical information

Linear Systems
Structure and benefits



Linear guides

FDA
FDB
FDC
FDD

FDE
FDG
FDH



Linear tables
Linear modules

FTB
FTC
FTD

FTI
FTH



Accessories

Technical information

Characteristics	Diameter range
<ul style="list-style-type: none"> • Maximum possible integration capacity • Series application to meet cost constraints • Greatest possible flexibility based on preload, runnability and diameter ranges 	<ul style="list-style-type: none"> • Infinitely variable from 70 to 2000 mm
<ul style="list-style-type: none"> • Simple, compact integration, LSA, infinitely variable Ø range • Cost-effective alternative to standard slim bearings • Not preloaded bearings 	<ul style="list-style-type: none"> • LSA infinitely variable from 3" to 30" • LSB graded from 4.75" to 25" (rated slim bearing dimensions)
<ul style="list-style-type: none"> • Ready to install in a large selection range • Preloaded free from clearance (optimized for rigidity, speed and service life) • Available on short notice • LVC type for high speeds 	<ul style="list-style-type: none"> • Infinitely variable from 100 to 1800 mm • Selected diameters available ex works
<ul style="list-style-type: none"> • Rotary tables for fast-rotating or highly-precise handling and measurement tasks • Bearing assemblies with direct drive • All systems complete with motor and control, available as one-stop solutions 	<ul style="list-style-type: none"> • Rotary tables LTA and LTB graded from 100 to 400 mm
<ul style="list-style-type: none"> • Washers for bearing assemblies • Ball cages made of various materials • Various kinds of seal 	
<ul style="list-style-type: none"> • Selection of suitable bearing • Calculation of stat./dynam. safety • Data on processing the bearing bed for bearing elements and slim bearings • Instructions on assembly and fastening 	

Characteristics	Stroke lengths
<ul style="list-style-type: none"> • Aluminium roller guides in various designs (e.g. non-corrosive, lubricant-free, LowCost) • All variations with inserted steel raceways • Large rollers for smooth and quiet running • Individually adjustable slide resistance 	<ul style="list-style-type: none"> • Infinitely variable from 200 to 4000 mm in one piece, infinitely coupled for longer stroke lengths
<ul style="list-style-type: none"> • Motorized modules with stroke lengths up to 7 m • Toothed belt and spindle drive • Linear module FTH with direct drive • LowCost module FTI with infinitely variable stroke lengths • Linear tables for precise positioning 	<ul style="list-style-type: none"> • Linear tables FTB, infinitely variable from 100 to 1500 mm • Linear modules with spindle/toothed belt drive, infinitely variable from 100 to 7000 mm • FTH with direct drive from 170 to 3625 mm
<ul style="list-style-type: none"> • Cassette with clamping device • Scraper and bellows to prevent dirt • Cap on the fastening bores • Fastening for the linear modules • Drive shafts and limit switches 	
<ul style="list-style-type: none"> • Accuracies, slide resistances • Instructions for assembly and adjustment • Details on motorization and control of the linear modules • Calculation of the static safety and service life 	

YouTube



The video
Function principle of
Wire Race Bearings
at YouTube
Search term "Franke
Wire Race Bearings"

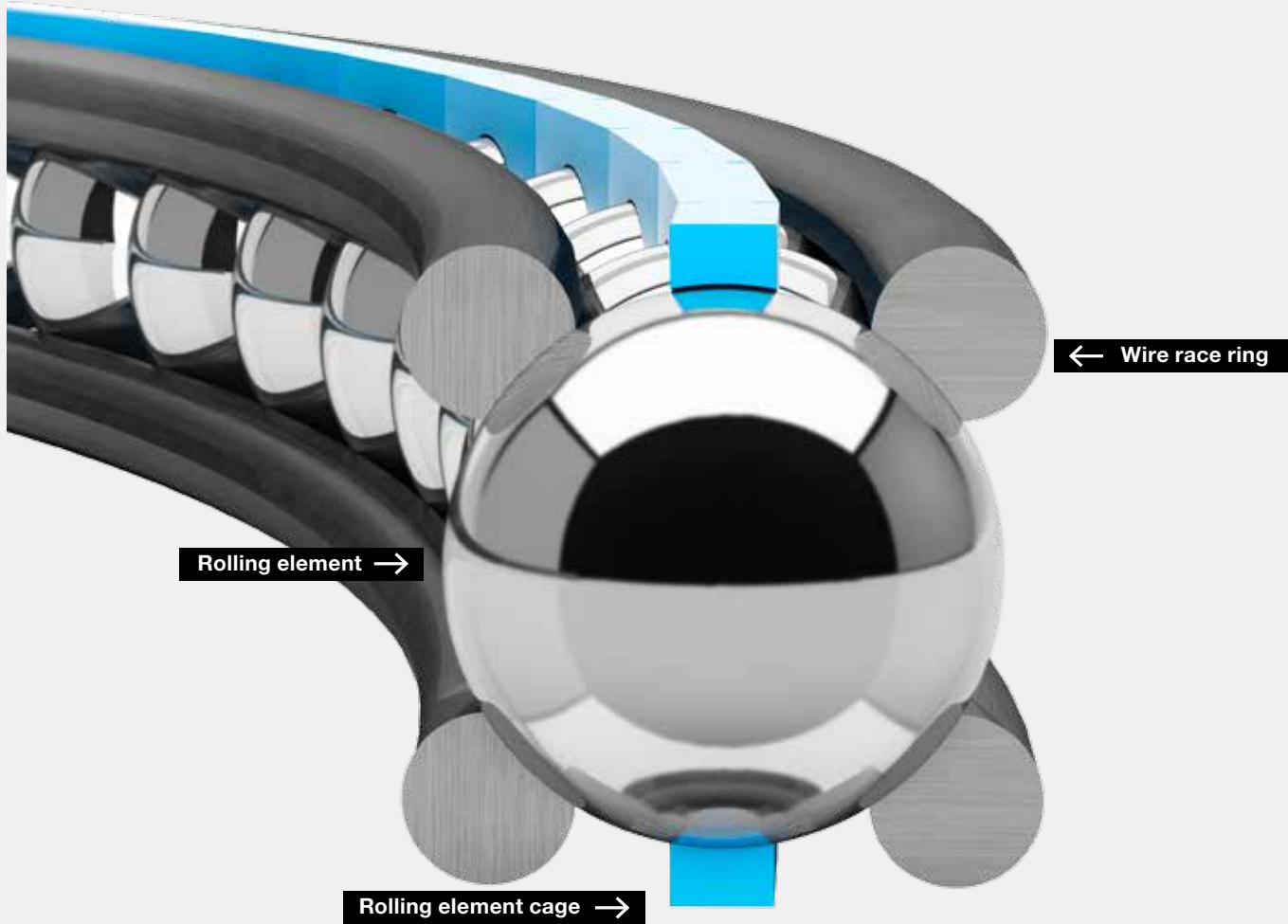

—
Bearing element

Wire Race Bearings

Franke Wire Race Bearings are delivered either separately as bearing elements (only race rings, rolling elements, cage) or together with the mating structure as ready-to-use bearing assemblies.

In both cases the rolling process does not take place like in standard bearings directly between the rolling element and the mating structure, but instead with low friction on the race rings.

This special construction principle produces an extremely compact and resilient bearing that can be adjusted to fit even the smallest mounting space. We offer individually customized solutions for your specific application, in addition to the standard program. The Wire Race Bearings are infinitely variable in size and can be customized individually; the material of the mating structure can be designed freely to suit the requirements.

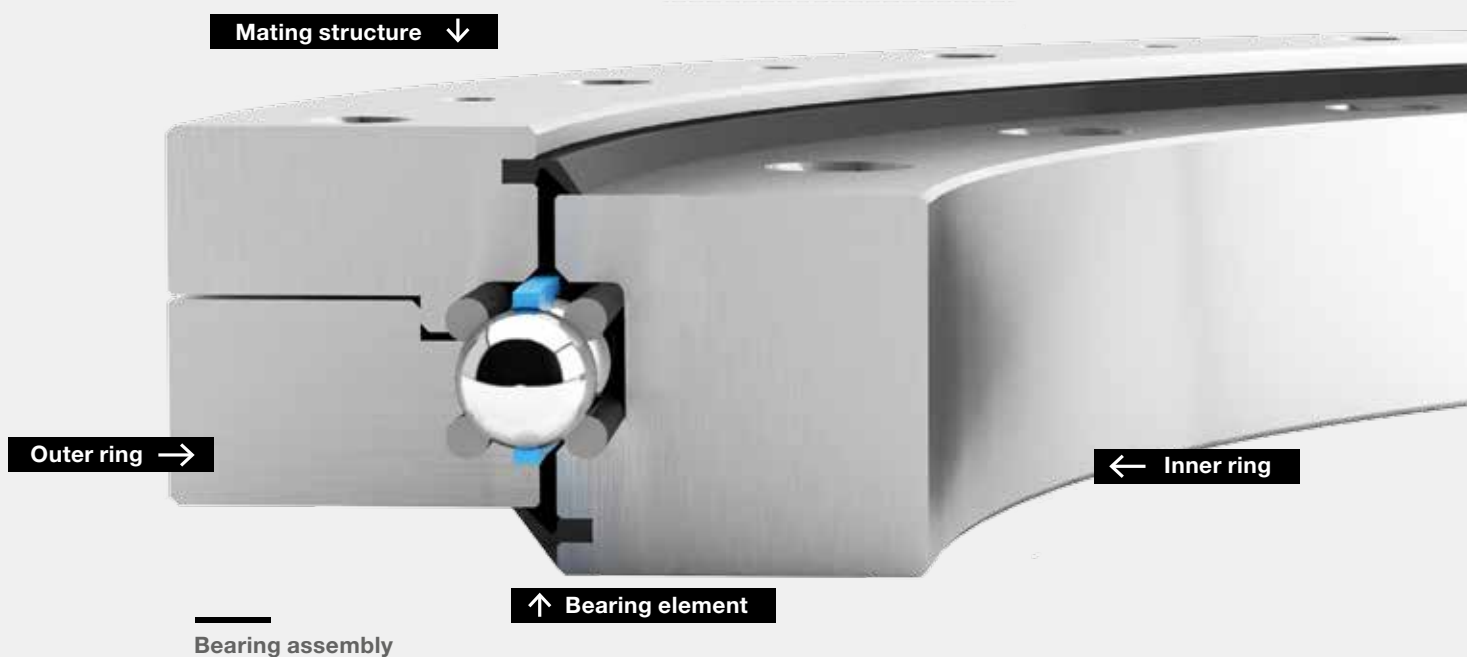

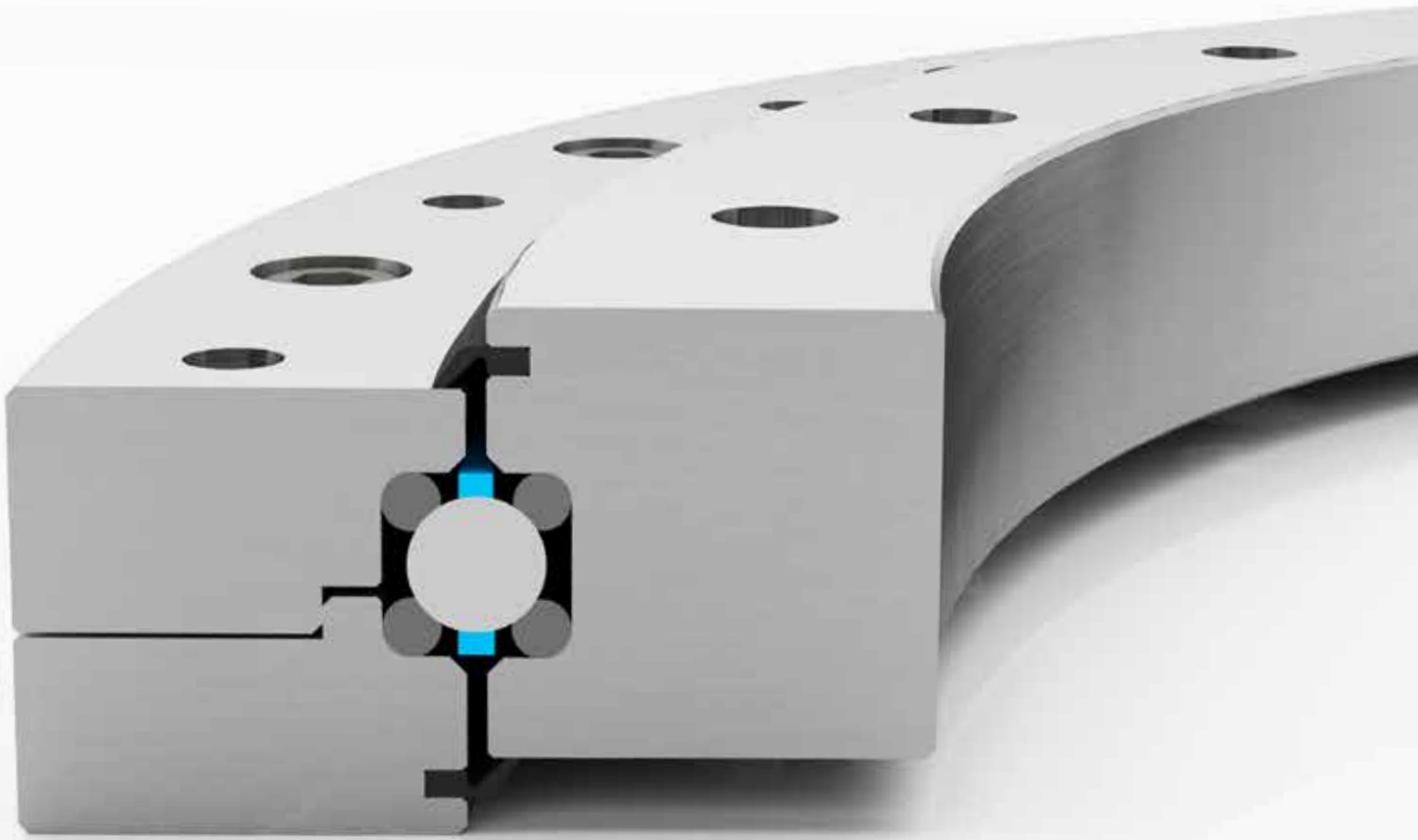

Why Wire Race Bearings?

Franke Wire Race Bearings offer you a broad range of options to construct special bearings customized to suit your individual application, in addition to the standard program.

4-point system – resilience from all directions

The arrangement of the race rings ensures even loading resilience of the bearings from all directions. This applies equally to the double row angular contact ball bearings.

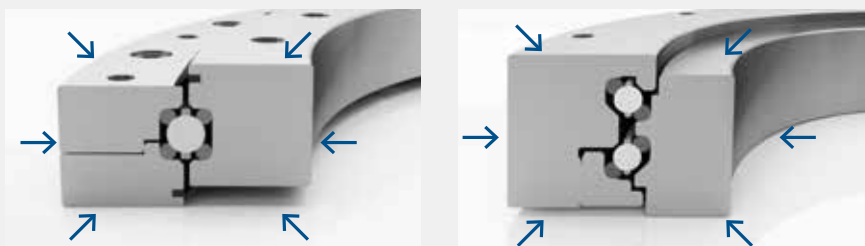

Freely adjustable rotational resistance – a preloaded system

Franke Wire Race Bearings can be aligned and adjusted. This takes place using washers, solid adjustment or adjusting ring.

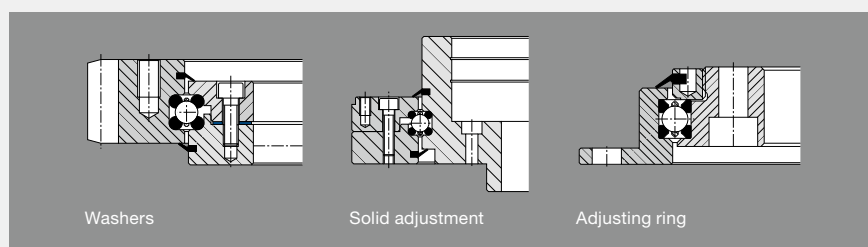

Compact design – minimum mounting space

Franke Wire Race Bearings can be integrated directly into your mating design. Our smallest bearing element requires a mere 4 x 7 mm mounting space.

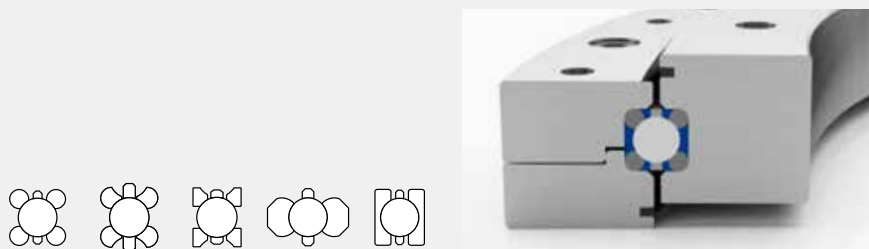

Angular contact ball bearings for highly-dynamic applications

The race rings in the Franke Wire Race Bearings can be arranged individually and also combined to form multi-row bearings. Arranged as angular contact ball bearings, they become highly-dynamic rotational systems for high-end applications.

- Circumferential speeds up to 20 m/s
- Rotational speeds up to 300 rpm
- Elastomer damping for < 60 db(A) (full load)
- Integrated direct drive

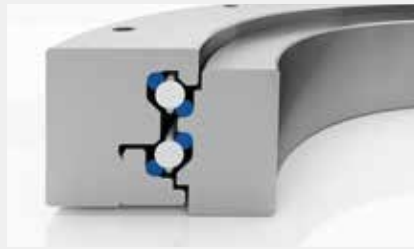

Free selection of bearing geometry – design your bearings individually

The housing components are not directly exposed to load from the rolling elements and can be constructed with extremely thin walls. This produces compact and lightweight components in conjunction with the small mounting space the Wire Race Bearings require.

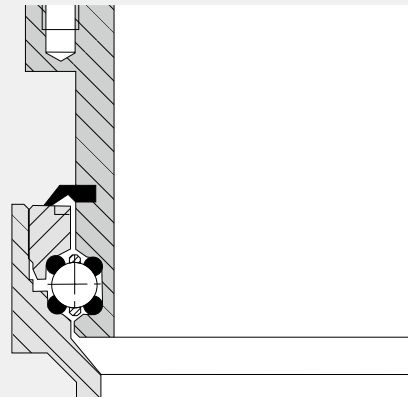

Geared outer and inner ring

All gears available in all qualities on request. We also deliver the required pinions or drives.

- Straight gear
- Angular gear
- Toothed belt gear
- Worm gear
- Special gear



Free material selection for the mating structure

Franke Wire Race Bearings deliver the requisite rigidity and accuracy of the bearing in almost any mating structure. They carry the principal load. Alternative materials for the mating structure are:

- Steel
- Aluminium
- Cast
- Bronze
- Plastic
- Carbon
- Non-corrosive
- Special seals (Viton)
- Coatings (ZnFe, electroless nickel, ATC)

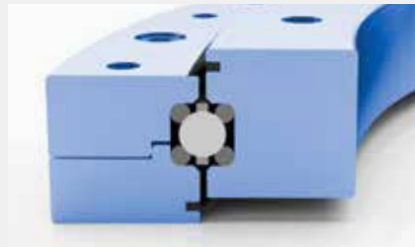

Depending on the material used the weight savings compared with standard steel bearings can be up to 65 %.

Free material selection of the bearing element

By standard, Franke Wire Race Bearings are manufactured using tough, hard spring steel. Alternatively other materials can be used for special applications, including:

- Hardened steel
- Non-corrosive
- Coatings (ZnFe, electroless nickel, ATC)
- Non-corrosive balls
- Ceramic balls
- Special cages (non-corrosive, hard fabric, brass)
- Adjusted raceway osculation
- Adjusted carrying angle
- Special grease
- Non-lubricant design

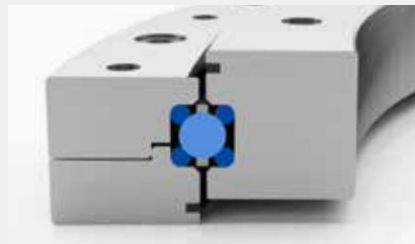

Insensitive to ambient conditions, elastic to shock/impact

The inner elasticity of the open race rings makes Franke Wire Race Bearings insensitive to ambient conditions, including:

- Temperature fluctuations
- Pressure differences
- Housing torsion
- Vibration



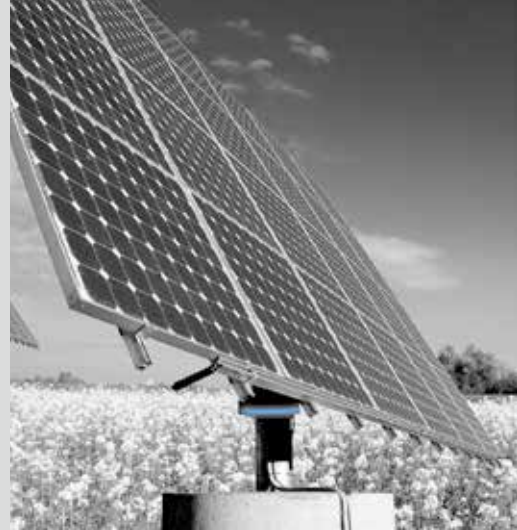
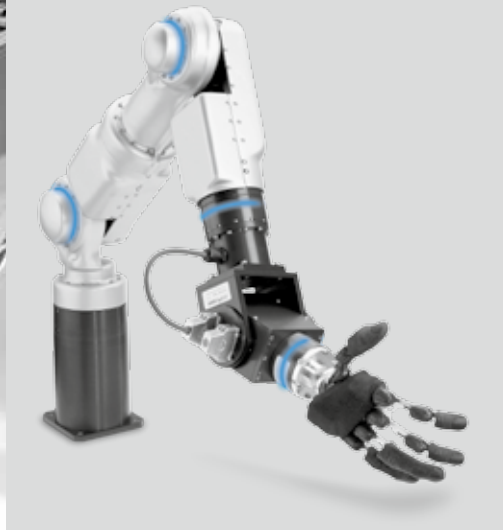
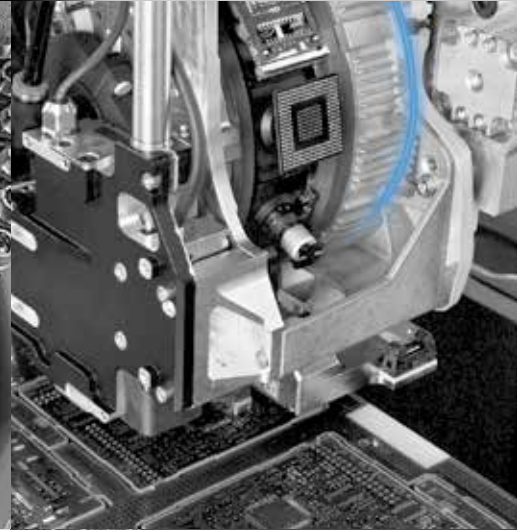
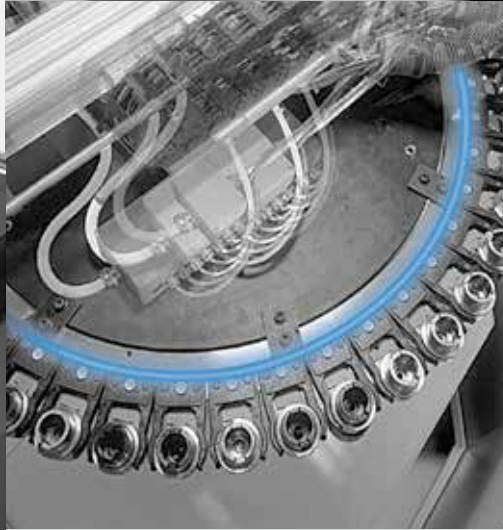
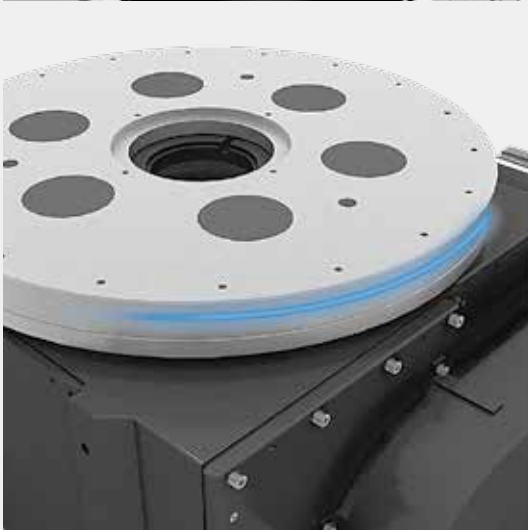

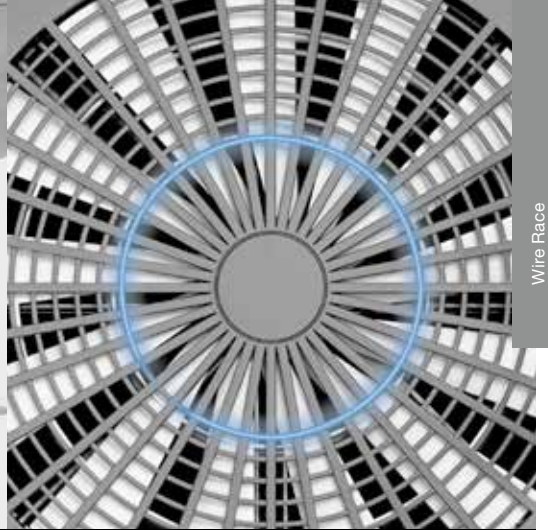
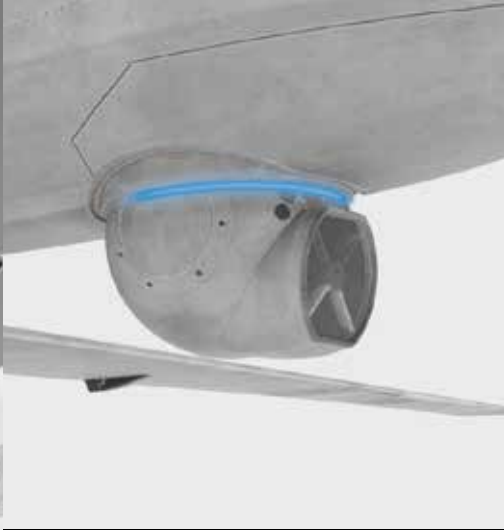

In all industries

Franke Wire Race Bearings. Universal design freedom. Performance in all applications. The big picture. In detail.



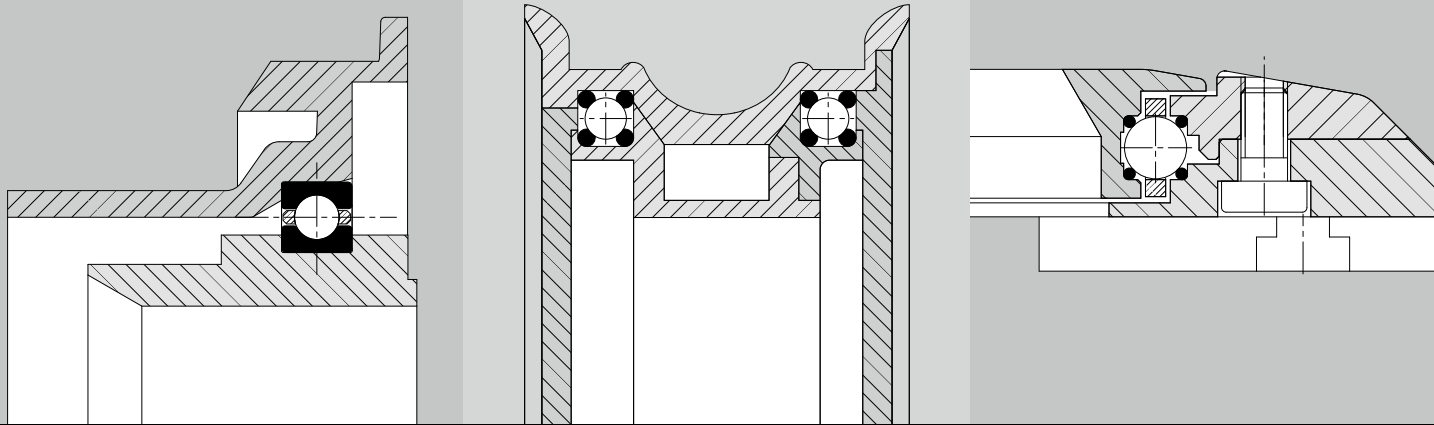

Entirely wired

Franke Wire Race Bearings. Light. Versatile. Adaptable. Individually adjustable. Space-saving. Quiet. Innovative. Low-friction. Universally usable.

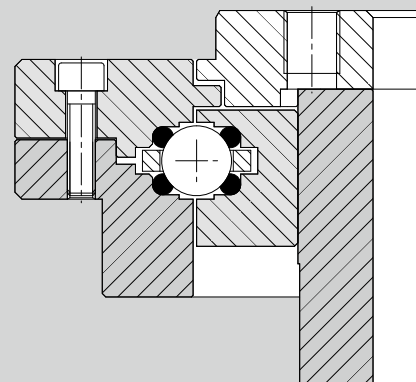
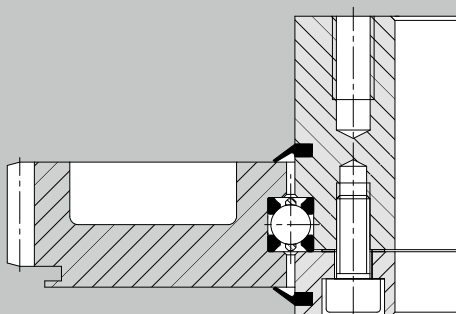
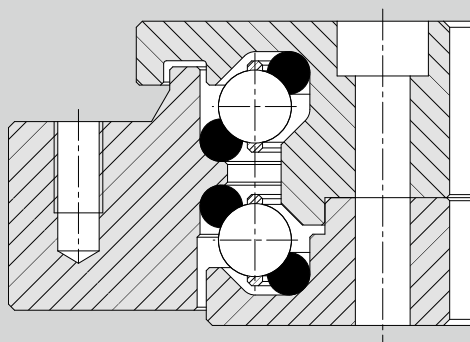
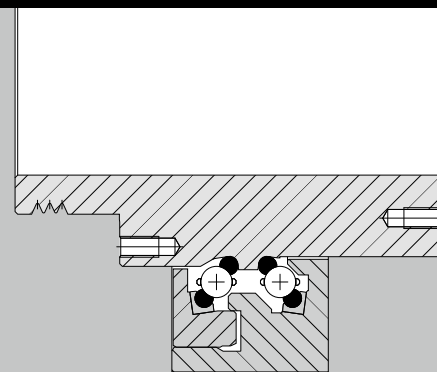
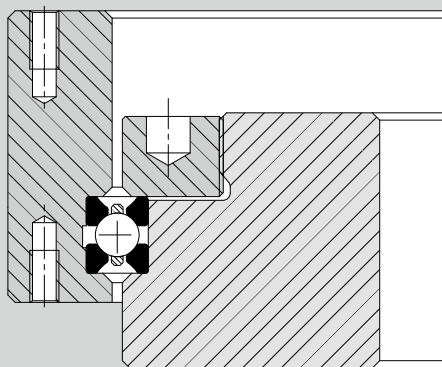
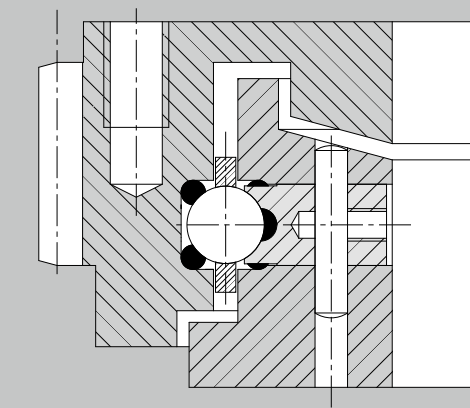





Roundly successful

Wire Race Bearings in all designs. Broad size spectrum. Free material selection for the bearing assembly. Also with own drive. Traditional quality standard in the services of innovation.





Bearing Elements



Type	Characteristic	KKØ	Page
LEL1.5	Ground raceway	70–150	22–23
LEL2.5	Ground raceway	160–300	22–23
LEL4	Ground raceway	200–1500	24–25
LEL5	Ground raceway	220–1500	26–27
LEL7	Ground raceway	340–2000	28–29
LER2	Rectangular profile/profiled raceway	80–400	30–31
LER3	Rectangular profile/profiled raceway	100–1000	30–31
LER4	Rectangular profile/profiled raceway	200–1500	32–33
LER5	Rectangular profile/profiled raceway	250–1800	32–33

Bearing Elements

Ground raceway

Type LEL

LEL1.5

KKØ mm	Load rating kN				Stat. moment kNm	Weight kg
	C_{0a}	C_{0r}	C_a	C_r		
LEL1.5-0070	13	6	7	6	0.2	0.04
LEL1.5-0080	15	7	7	6	0.3	0.05
LEL1.5-0090	18	8	8	7	0.4	0.05
LEL1.5-0100	20	9	8	7	0.5	0.06
LEL1.5-0110	22	10	8	7	0.6	0.07
LEL1.5-0120	23	11	9	8	0.7	0.07
LEL1.5-0130	25	12	9	8	0.8	0.08
LEL1.5-0140	27	13	9	8	0.9	0.09
LEL1.5-0150	30	14	10	8	1.0	0.09

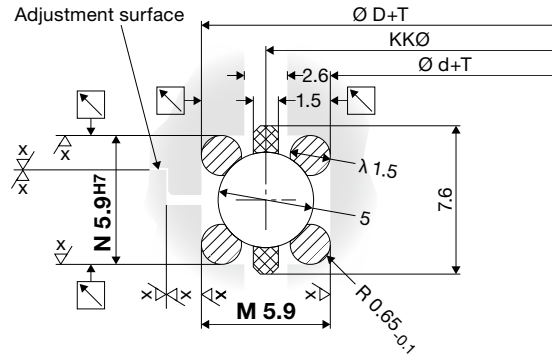

LEL2.5

KKØ mm	Load rating kN				Stat. moment kNm	Weight kg
	C_{0a}	C_{0r}	C_a	C_r		
LEL2.5-0160	73	35	20	17	3	0.10
LEL2.5-0170	79	37	20	17	3	0.11
LEL2.5-0180	83	39	20	18	3	0.11
LEL2.5-0190	88	41	21	18	4	0.12
LEL2.5-0200	93	43	21	18	4	0.12
LEL2.5-0210	97	46	22	19	5	0.13
LEL2.5-0220	102	48	22	19	5	0.13
LEL2.5-0230	106	50	22	19	6	0.14
LEL2.5-0240	112	53	23	20	6	0.15
LEL2.5-0250	117	55	23	20	7	0.15
LEL2.5-0260	121	57	24	20	7	0.16
LEL2.5-0270	126	59	24	21	8	0.16
LEL2.5-0280	130	61	24	21	9	0.17
LEL2.5-0290	135	64	25	21	9	0.18
LEL2.5-0300	141	66	25	22	10	0.18

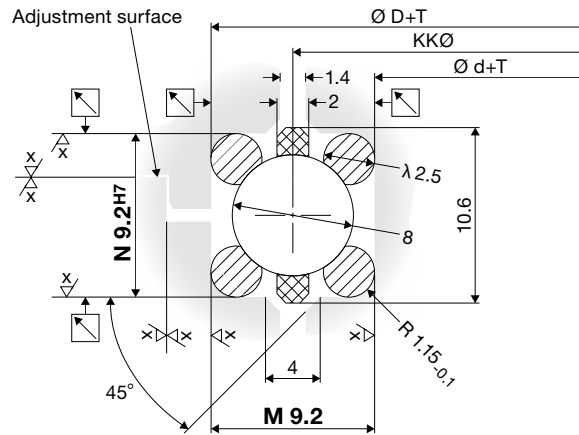

KKØ ≤ 500 mm T = IT6 KKØ > 500 mm T = IT7 $\sqrt{R_a} = Ra 3.2$
Available infinitely variable in all intermediate diameters.



Bearing type

Franke bearing elements in type LEL meet high standards in terms of runnability and accuracy. Their hardened and CNC-ground raceways, along with the ideal geometric adjustment of ball and raceway radius, lend them outstanding bearing properties. Bearing elements in the LEL type permit the greatest possible freedom of bearing design. The standard mounting space is between 5.9 mm and 20.9 mm. Race ring thickness of up to 20 mm and bearing sizes up to 50 mm are possible to meet special requirements.

Characteristics

Bearing elements of the LEL type consist of two inner and two outer raceways, along with a plastic cage with retained balls. The race rings are divided at one point to compensate for the temperature expansion factor. They possess compensatory properties for demanding forms of stress. LEL are generally mounted free from clearance. The preload can be defined individually to meet the specific requirement. See 'Technical information' for the adjustment methods.

Mating structure

The bearing element mounted determines the overall construction's load bearing capacity. Hence the mating construction can be made of alternative materials such as steel, aluminium or plastic. Axial and radial accuracy (see diagram below) are defined to a substantial extent by the mating components. These properties can be enhanced by boosting the accuracy of manufacture.

Please find construction examples, special forms, special accuracies and other options of individual tailoring on pages 11 – 19.

Technical details

Material	Ball race rings: 54SiCr6, rolling element: 100Cr6, cage: PA12
Temperature in use	-30 °C to +80 °C, briefly up to +100 °C
Circumferential speed	max. 5 m/s, without seals max. 10 m/s
Lubricant grease	Klüber ISOFLEX TOPAS NCA52
Lubrication schedule	See 'Technical information'.
Tolerance details	See 'Technical information'.

Please find additional data on calculation, mounting and setting in 'Technical information'.

Constructive example

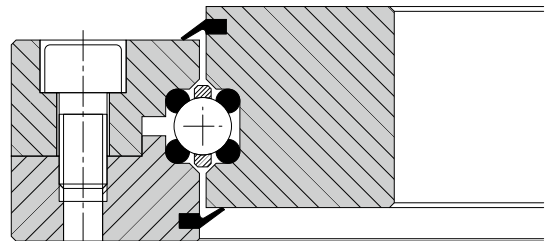

Rotational resistance

The rotational resistance indicates the preload on the bearing assembly. It is dependent on the respective type and the race ring diameter. The values indicated in the diagram are standard values and can be aligned individually.

Radial and axial runout accuracy

The running accuracies indicated in the diagram are maximum values and may be improved by restricting the tolerances.

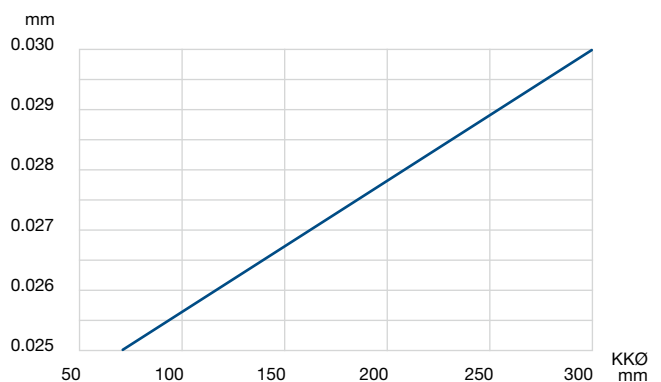
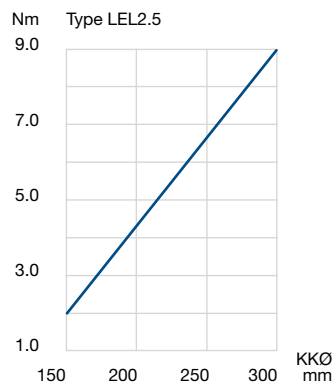
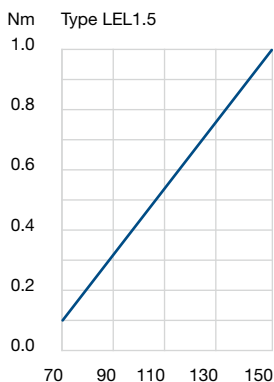

Bearing Elements

Ground raceway

Type LEL

LEL4

KKØ mm	Load rating kN				Stat. moment kNm	Weight kg
	C_{0a}	C_{0r}	C_a	C_r		
LEL4-0200	118	55	26	23	6	0.39
LEL4-0210	123	58	26	23	6	0.41
LEL4-0220	131	62	27	24	7	0.43
LEL4-0230	136	64	28	24	7	0.45
LEL4-0240	142	67	28	24	8	0.47
LEL4-0250	147	69	28	25	9	0.49
LEL4-0260	155	73	29	25	10	0.51
LEL4-0270	161	76	29	25	10	0.53
LEL4-0280	166	78	30	26	11	0.55
LEL4-0290	172	81	30	26	12	0.57
LEL4-0300	177	83	30	26	13	0.59
LEL4-0320	191	90	31	27	14	0.63
LEL4-0340	202	95	32	28	16	0.66
LEL4-0360	215	101	33	28	18	0.71
LEL4-0380	226	106	33	29	20	0.74
LEL4-0400	240	113	34	29	23	0.78
LEL4-0420	251	118	35	30	25	0.82
LEL4-0440	264	124	35	30	27	0.86
LEL4-0460	275	129	36	31	30	0.90
LEL4-0480	289	136	36	31	33	0.94
LEL4-0500	299	141	37	32	35	0.98
LEL4-0520	313	147	37	32	38	1.02
LEL4-0540	324	152	38	33	41	1.06
LEL4-0560	337	159	39	33	44	1.10
LEL4-0580	348	164	39	34	48	1.14
LEL4-0600	359	169	39	34	51	1.17
LEL4-0620	373	175	40	35	54	1.22
LEL4-0640	384	180	40	35	58	1.25
LEL4-0660	397	187	41	35	62	1.29
LEL4-0680	408	192	41	36	65	1.33
LEL4-0700	442	198	42	36	69	1.37
LEL4-0720	432	203	42	37	73	1.41
LEL4-0740	446	210	43	37	78	1.45
LEL4-0760	457	215	43	37	81	1.49
LEL4-0780	470	221	44	38	86	1.53
LEL4-0800	481	226	44	38	91	1.57
LEL4-0820	495	233	44	38	95	1.61
LEL4-0840	506	238	45	39	100	1.65
LEL4-0860	519	244	45	39	105	1.68
LEL4-0880	580	249	45	39	110	1.73
LEL4-0900	541	255	46	40	115	1.76
LEL4-0920	555	261	46	40	120	1.80
LEL4-0960	579	272	47	41	131	1.88
LEL4-1000	603	284	48	41	142	1.96
LEL4-1100	663	312	49	43	172	2.16
LEL4-1200	723	340	51	44	204	2.35
LEL4-1300	785	370	52	45	240	2.55
LEL4-1400	845	398	54	47	278	2.75
LEL4-1500	905	426	55	48	319	2.94

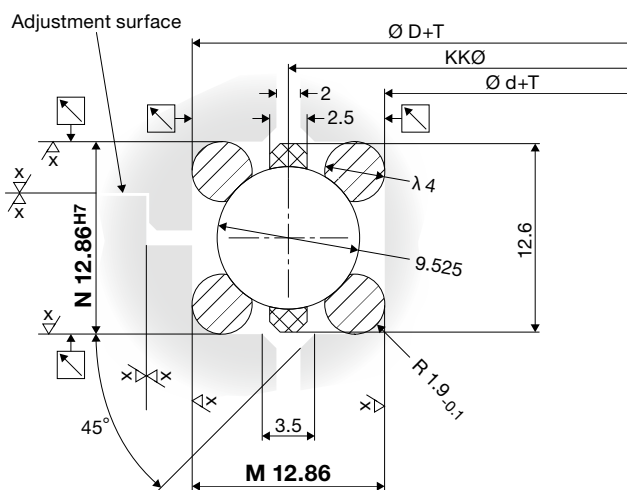

KKØ ≤ 500 mm T = IT6 KKØ > 500 mm T = IT7 $\frac{X}{\sqrt{}} = Ra 3.2$
 Available infinitely variable in all intermediate diameters.



Bearing type

Franke bearing elements in type LEL meet high standards in terms of runnability and accuracy. Their hardened and CNC-ground raceways, along with the ideal geometric adjustment of ball and raceway radius, lend them outstanding bearing properties. Bearing elements in the LEL type permit the greatest possible freedom of bearing design. The standard mounting space is between 5.9 mm and 20.9 mm. Race ring thickness of up to 20 mm and bearing sizes up to 50 mm are possible to meet special requirements.

Characteristics

Bearing elements of the LEL type consist of two inner and two outer raceways, along with a plastic cage with retained balls. The race rings are divided at one point to compensate for the temperature expansion factor. They possess compensatory properties for demanding forms of stress. LEL are generally mounted free from clearance. The preload can be defined individually to meet the specific requirement. See 'Technical information' for the adjustment methods.

Mating structure

The bearing element mounted determines the overall construction's load bearing capacity. Hence the mating construction can be made of alternative materials such as steel, aluminium or plastic. Axial and radial accuracy (see diagram below) are defined to a substantial extent by the mating components. These properties can be enhanced by boosting the accuracy of manufacture.

Please find construction examples, special forms, special accuracies and other options of individual tailoring on pages 11 – 19.

Technical details

Material	Ball race rings: 54SiCr6, rolling element: 100Cr6, cage: PA12
Temperature in use	-30 °C to +80 °C, briefly up to +100 °C
Circumferential speed	max. 5 m/s, without seals max. 10 m/s
Lubricant grease	Klüber ISOFLEX TOPAS NCA52
Lubrication schedule	See 'Technical information'.
Tolerance details	See 'Technical information'.

Please find additional data on calculation, mounting and setting in 'Technical information'.

Constructive example

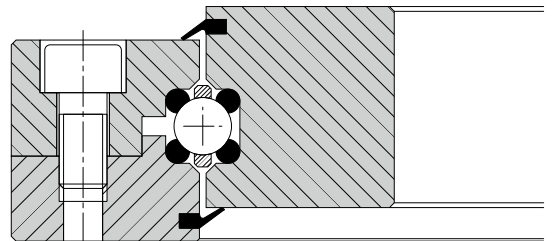

Rotational resistance

The rotational resistance indicates the preload on the bearing assembly. It is dependent on the respective type and the race ring diameter. The values indicated in the diagram are standard values and can be aligned individually.

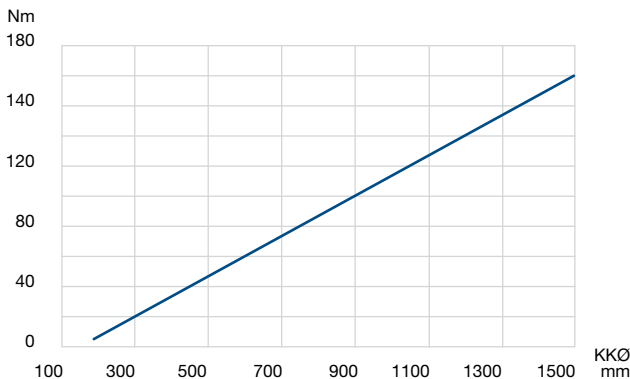

Radial and axial runout accuracy

The running accuracies indicated in the diagram are maximum values and may be improved by restricting the tolerances.

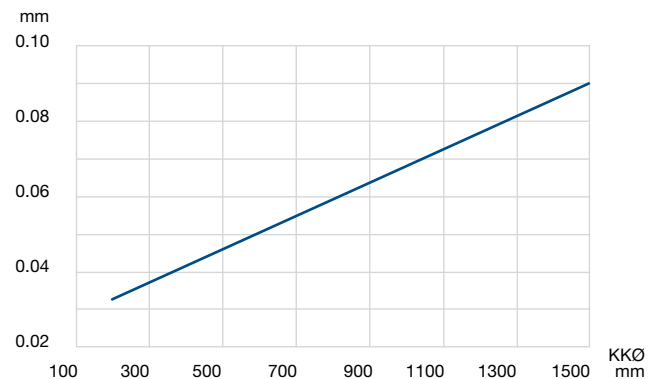

Bearing Elements

Ground raceway

Type LEL

LEL5

KKØ mm	Load rating kN				Stat. moment kNm	Weight kg
	C_{0a}	C_{0r}	C_a	C_r		
LEL5-0220	257	121	41	35	13	0.70
LEL5-0230	267	126	41	36	15	0.73
LEL5-0240	279	131	42	36	16	0.76
LEL5-0250	289	136	43	37	17	0.79
LEL5-0260	305	144	44	38	19	0.82
LEL5-0270	316	149	44	38	20	0.85
LEL5-0280	327	154	45	39	22	0.88
LEL5-0290	337	159	45	39	23	0.91
LEL5-0300	348	164	46	39	25	0.94
LEL5-0320	375	176	47	41	28	1.02
LEL5-0340	396	187	48	41	32	1.08
LEL5-0360	423	199	49	42	36	1.14
LEL5-0380	444	209	50	43	40	1.20
LEL5-0400	471	222	51	44	44	1.26
LEL5-0420	493	232	52	45	49	1.33
LEL5-0440	519	244	53	46	54	1.40
LEL5-0460	541	254	54	46	59	1.46
LEL5-0480	567	267	55	47	64	1.53
LEL5-0500	589	277	55	48	69	1.59
LEL5-0520	616	290	56	49	75	1.66
LEL5-0540	637	300	57	49	81	1.72
LEL5-0560	664	312	58	50	87	1.78
LEL5-0580	685	322	59	51	94	1.85
LEL5-0600	707	333	59	51	100	1.91
LEL5-0620	733	345	60	52	107	1.97
LEL5-0640	755	355	61	53	114	2.03
LEL5-0660	781	367	62	53	121	2.09
LEL5-0680	803	378	62	54	128	2.16
LEL5-0700	830	390	63	54	137	2.23
LEL5-0720	851	400	63	55	144	2.29
LEL5-0740	878	413	64	56	153	2.36
LEL5-0760	899	423	65	56	161	2.43
LEL5-0780	926	436	66	57	170	2.49
LEL5-0800	947	446	66	57	178	2.55
LEL5-0820	974	458	67	58	188	2.61
LEL5-0840	995	468	67	58	197	2.67
LEL5-0860	1022	484	68	59	207	2.74
LEL5-0880	1044	491	68	59	216	2.80
LEL5-0900	1065	501	69	60	226	2.86
LEL5-0920	1092	514	70	60	236	2.92
LEL5-0940	1113	524	70	61	246	2.98
LEL5-0960	1140	536	71	61	257	3.04
LEL5-0980	1161	546	71	62	268	3.10
LEL5-1000	1188	559	72	62	280	3.19
LEL5-1100	1306	614	74	64	338	3.50
LEL5-1200	1423	670	77	66	402	3.82
LEL5-1300	1546	728	79	68	473	4.14
LEL5-1400	1664	783	81	70	548	4.46
LEL5-1500	1782	839	83	72	629	4.77

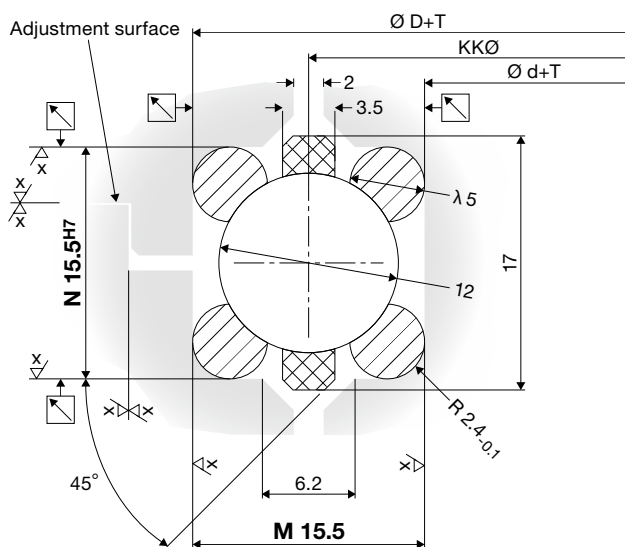

KKØ ≤ 500 mm T = IT6 KKØ > 500 mm T = IT7 $\sqrt{R_a} = Ra\ 3.2$
 Available infinitely variable in all intermediate diameters.



Bearing type

Franke bearing elements in type LEL meet high standards in terms of runnability and accuracy. Their hardened and CNC-ground raceways, along with the ideal geometric adjustment of ball and raceway radius, lend them outstanding bearing properties. Bearing elements in the LEL type permit the greatest possible freedom of bearing design. The standard mounting space is between 5.9 mm and 20.9 mm. Race ring thickness of up to 20 mm and bearing sizes up to 50 mm are possible to meet special requirements.

Characteristics

Bearing elements of the LEL type consist of two inner and two outer raceways, along with a plastic cage with retained balls. The race rings are divided at one point to compensate for the temperature expansion factor. They possess compensatory properties for demanding forms of stress. LEL are generally mounted free from clearance. The preload can be defined individually to meet the specific requirement. See 'Technical information' for the adjustment methods.

Mating structure

The bearing element mounted determines the overall construction's load bearing capacity. Hence the mating construction can be made of alternative materials such as steel, aluminium or plastic. Axial and radial accuracy (see diagram below) are defined to a substantial extent by the mating components. These properties can be enhanced by boosting the accuracy of manufacture.

Please find construction examples, special forms, special accuracies and other options of individual tailoring on pages 11 – 19.

Technical details

Material	Ball race rings: 54SiCr6, rolling element: 100Cr6, cage: PA12
Temperature in use	-30 °C to +80 °C, briefly up to +100 °C
Circumferential speed	max. 5 m/s, without seals max. 10 m/s
Lubricant grease	Klüber ISOFLEX TOPAS NCA52
Lubrication schedule	See 'Technical information'.
Tolerance details	See 'Technical information'.

Please find additional data on calculation, mounting and setting in 'Technical information'.

Constructive example

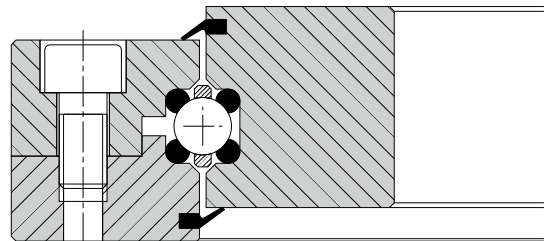

Rotational resistance

The rotational resistance indicates the preload on the bearing assembly. It is dependent on the respective type and the race ring diameter. The values indicated in the diagram are standard values and can be aligned individually.

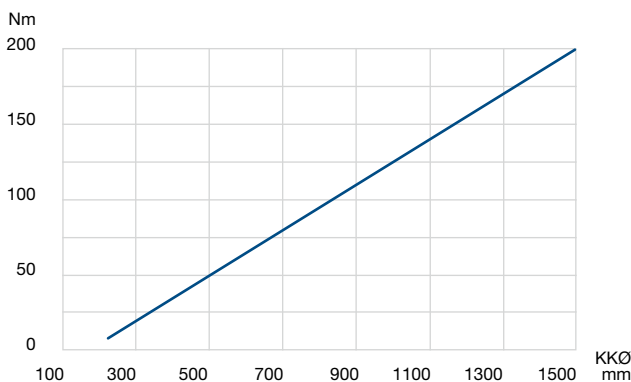

Radial and axial runout accuracy

The running accuracies indicated in the diagram are maximum values and may be improved by restricting the tolerances.

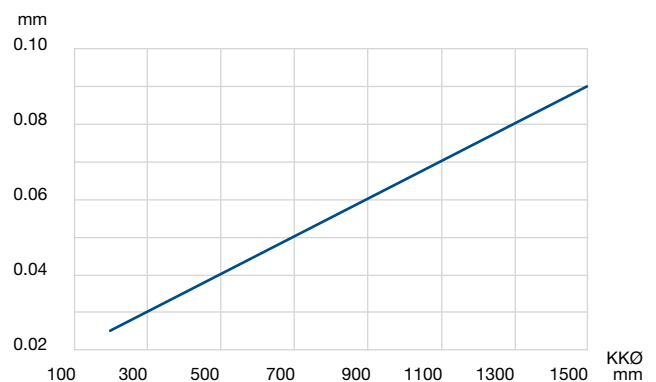

Bearing Elements

Ground raceway

Type LEL

LEL7

KKØ mm	Load rating kN				Stat. moment kNm	Weight kg
	C_{0a}	C_{0r}	C_a	C_r		
LEL7-0340	441	207	62	53	35	1.89
LEL7-0360	466	219	63	54	39	2.02
LEL7-0380	491	231	64	55	44	2.13
LEL7-0400	517	243	65	56	49	2.24
LEL7-0420	542	255	66	57	54	2.35
LEL7-0440	567	267	67	58	59	2.46
LEL7-0460	593	279	68	59	64	2.57
LEL7-0480	626	295	70	61	71	2.68
LEL7-0500	652	307	71	61	77	2.79
LEL7-0520	677	319	72	62	83	2.92
LEL7-0540	703	331	73	63	89	3.03
LEL7-0560	728	343	74	64	96	3.14
LEL7-0580	753	355	75	65	103	3.25
LEL7-0600	779	366	76	66	110	3.36
LEL7-0620	804	378	77	66	117	3.47
LEL7-0640	838	394	78	67	126	3.58
LEL7-0660	863	406	79	68	134	3.69
LEL7-0680	888	418	80	69	142	3.82
LEL7-0700	914	430	81	70	151	3.93
LEL7-0720	939	442	81	70	159	4.04
LEL7-0740	964	454	82	71	168	4.15
LEL7-0760	990	466	83	72	177	4.26
LEL7-0780	1015	478	84	72	186	4.37
LEL7-0800	1049	494	85	73	197	4.48
LEL7-0820	1074	506	85	74	207	4.61
LEL7-0840	1100	517	86	75	217	4.72
LEL7-0860	1125	529	87	75	228	4.83
LEL7-0880	1150	541	88	76	238	4.94
LEL7-0900	1176	553	88	76	249	5.05
LEL7-0920	1201	565	89	77	260	5.16
LEL7-0940	1226	577	90	77	271	5.27
LEL7-0960	1260	593	91	78	285	5.38
LEL7-0980	1286	605	91	79	296	5.49
LEL7-1000	1311	617	92	80	308	5.60
LEL7-1060	1387	653	94	81	356	5.95
LEL7-1100	1438	677	95	82	372	6.17
LEL7-1160	1522	716	97	84	415	6.52
LEL7-1200	1573	740	98	85	444	6.74
LEL7-1260	1649	776	100	86	489	7.07
LEL7-1300	1708	804	101	88	522	7.29
LEL7-1360	1784	840	103	89	571	7.64
LEL7-1400	1835	863	104	90	604	7.86
LEL7-1460	1919	903	106	91	660	8.19
LEL7-1500	1970	927	107	92	695	8.43
LEL7-1600	2105	991	109	95	793	8.65
LEL7-1700	2232	1050	112	97	893	9.09
LEL7-1800	2367	1114	114	99	1003	9.55
LEL7-1900	2503	1178	117	101	1119	9.77
LEL7-2000	2629	1237	119	103	1237	11.24

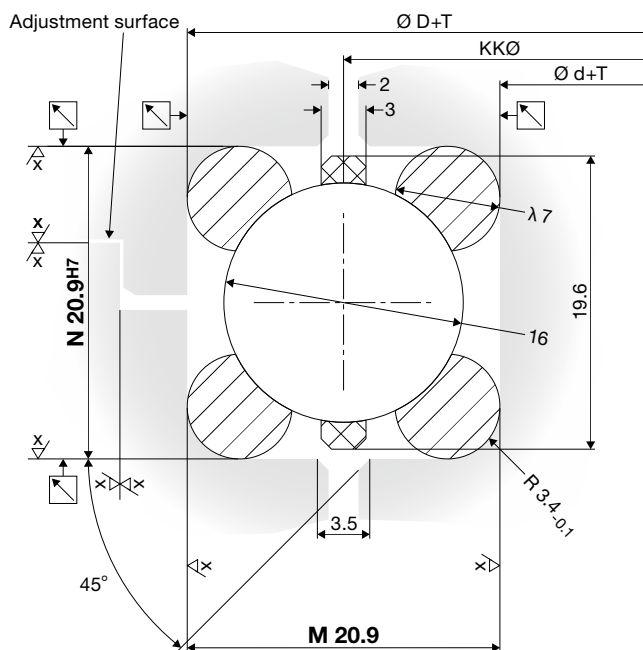

KKØ ≤ 500 mm T = IT6 KKØ > 500 mm T = IT7 X/√ = Ra 3.2
Available infinitely variable in all intermediate diameters.



Bearing type

Franke bearing elements in type LEL meet high standards in terms of runnability and accuracy. Their hardened and CNC-ground raceways, along with the ideal geometric adjustment of ball and raceway radius, lend them outstanding bearing properties. Bearing elements in the LEL type permit the greatest possible freedom of bearing design. The standard mounting space is between 5.9 mm and 20.9 mm. Race ring thickness of up to 20 mm and bearing sizes up to 50 mm are possible to meet special requirements.

Characteristics

Bearing elements of the LEL type consist of two inner and two outer raceways, along with a plastic cage with retained balls. The race rings are divided at one point to compensate for the temperature expansion factor. They possess compensatory properties for demanding forms of stress. LEL are generally mounted free from clearance. The preload can be defined individually to meet the specific requirement. See 'Technical information' for the adjustment methods.

Mating structure

The bearing element mounted determines the overall construction's load bearing capacity. Hence the mating construction can be made of alternative materials such as steel, aluminium or plastic. Axial and radial accuracy (see diagram below) are defined to a substantial extent by the mating components. These properties can be enhanced by boosting the accuracy of manufacture.

Please find construction examples, special forms, special accuracies and other options of individual tailoring on pages 11 – 19.

Technical details

Material	Ball race rings: 54SiCr6, rolling element: 100Cr6, cage: PA12
Temperature in use	-30 °C to +80 °C, briefly up to +100 °C
Circumferential speed	max. 5 m/s, without seals max. 10 m/s
Lubricant grease	Klüber ISOFLEX TOPAS NCA52
Lubrication schedule	See 'Technical information'.
Tolerance details	See 'Technical information'.

Please find additional data on calculation, mounting and setting in 'Technical information'.

Constructive example

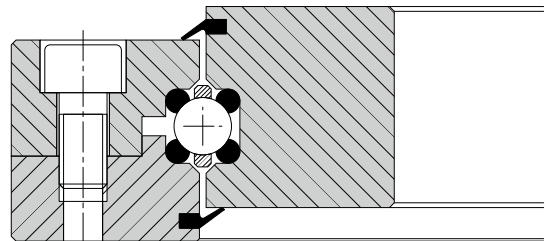

Rotational resistance

The rotational resistance indicates the preload on the bearing assembly. It is dependent on the respective type and the race ring diameter. The values indicated in the diagram are standard values and can be aligned individually.

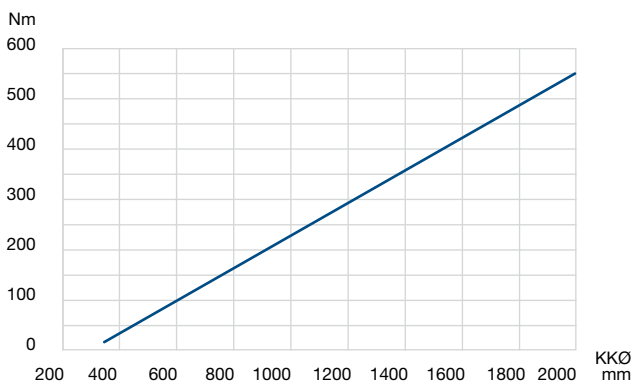

Radial and axial runout accuracy

The running accuracies indicated in the diagram are maximum values and may be improved by restricting the tolerances.

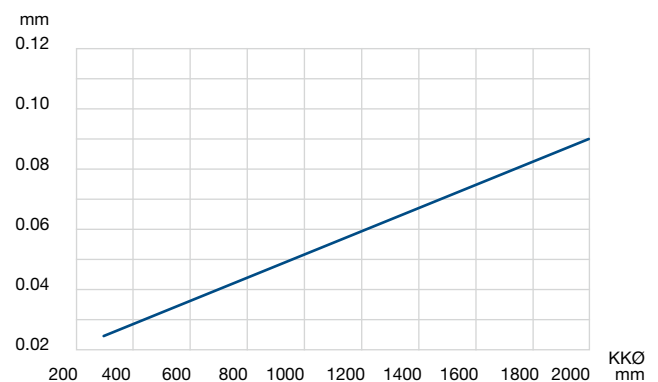



Bearing type

Franke bearing elements in type LER are designed for medium rotational speeds and accuracies. They run smoothly, possess high dynamism and require just compact mounting space. The straight contact surface ensures simple integration in the mating structure and also a high rigidity. The attractive price makes this bearing element type LER an economic solution.

Characteristics

Bearing elements of the LER type consist of two inner and two outer raceways, along with a plastic cage with retained balls. The race rings are divided at one point to compensate for the temperature expansion factor. They possess compensatory properties for demanding forms of stress. LER are generally mounted free from clearance. The preload can be defined individually to meet the specific requirement. See 'Technical information' for the adjustment methods.

Mating structure

The bearing element mounted determines the overall construction's load bearing capacity. Hence the mating construction can be made of alternative materials such as steel, aluminium or plastic. Axial and radial accuracy (see diagram below) are defined to a substantial extent by the mating components. These properties can be enhanced by boosting the accuracy of manufacture.

Please find construction examples, special forms, special accuracies and other options of individual tailoring on pages 11–19.

Technical details

Material	Ball race rings: 54SiCr6, rolling element: 100Cr6, cage: PA12
Temperature in use	–30 °C to +80 °C, briefly up to +100 °C
Circumferential speed	max. 5 m/s, without seals max. 10 m/s
Lubricant grease	Klüber ISOFLEX TOPAS NCA52
Lubrication schedule	See 'Technical information'.
Tolerance details	See 'Technical information'.

Please find additional data on calculation, mounting and setting in 'Technical information'.

Constructive example

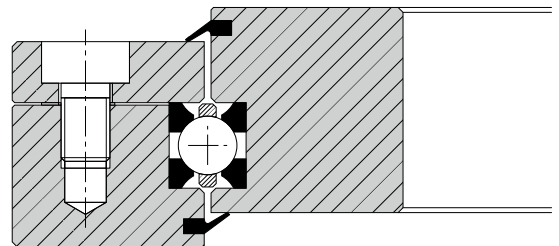

Rotational resistance

The rotational resistance indicates the preload on the bearing assembly. It is dependent on the respective type and the race ring diameter. The values indicated in the diagram are standard values and can be aligned individually.

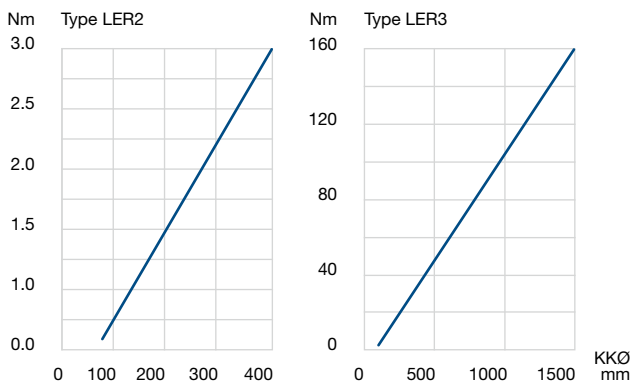

Radial and axial runout accuracy

The running accuracies indicated in the diagram are maximum values and may be improved by restricting the tolerances.

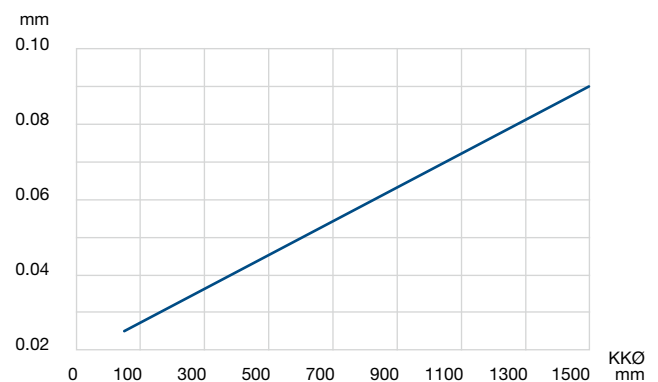



Bearing type

Franke bearing elements in type LER are designed for medium rotational speeds and accuracies. They run smoothly, possess high dynamism and require just compact mounting space. The straight contact surface ensures simple integration in the mating structure and also a high rigidity. The attractive price makes this bearing element type LER an economic solution.

Characteristics

Bearing elements of the LER type consist of two inner and two outer raceways, along with a plastic cage with retained balls. The race rings are divided at one point to compensate for the temperature expansion factor. They possess compensatory properties for demanding forms of stress. LER are generally mounted free from clearance. The preload can be defined individually to meet the specific requirement. See 'Technical information' for the adjustment methods.

Mating structure

The bearing element mounted determines the overall construction's load bearing capacity. Hence the mating construction can be made of alternative materials such as steel, aluminium or plastic. Axial and radial accuracy (see diagram below) are defined to a substantial extent by the mating components. These properties can be enhanced by boosting the accuracy of manufacture.

Please find construction examples, special forms, special accuracies and other options of individual tailoring on pages 11–19.

Technical details

Material	Ball race rings: 54SiCr6, rolling element: 100Cr6, cage: PA12
Temperature in use	–30 °C to +80 °C, briefly up to +100 °C
Circumferential speed	max. 5 m/s, without seals max. 10 m/s
Lubricant grease	Klüber ISOFLEX TOPAS NCA52
Lubrication schedule	See 'Technical information'.
Tolerance details	See 'Technical information'.

Please find additional data on calculation, mounting and setting in 'Technical information'.

Constructive example

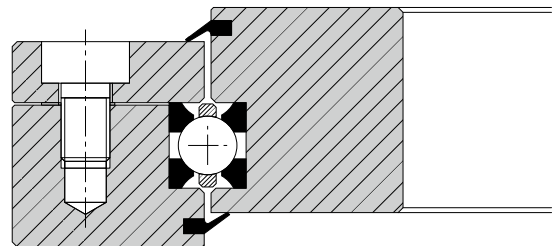

Rotational resistance

The rotational resistance indicates the preload on the bearing assembly. It is dependent on the respective type and the race ring diameter. The values indicated in the diagram are standard values and can be aligned individually.

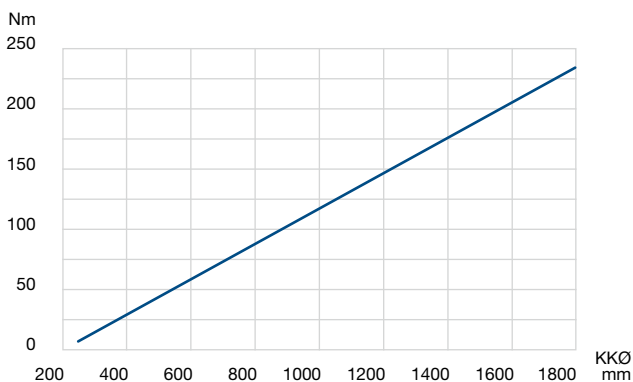

Radial and axial runout accuracy

The running accuracies indicated in the diagram are maximum values and may be improved by restricting the tolerances.

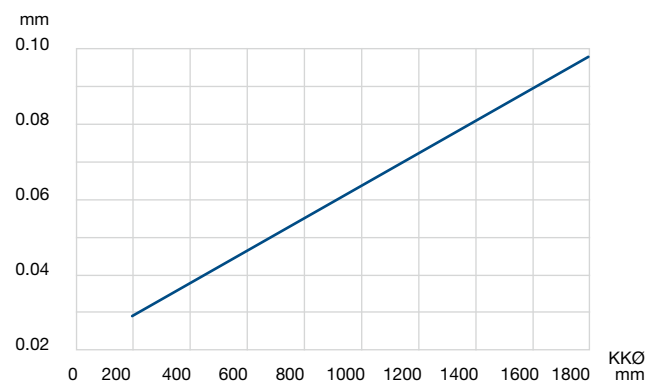

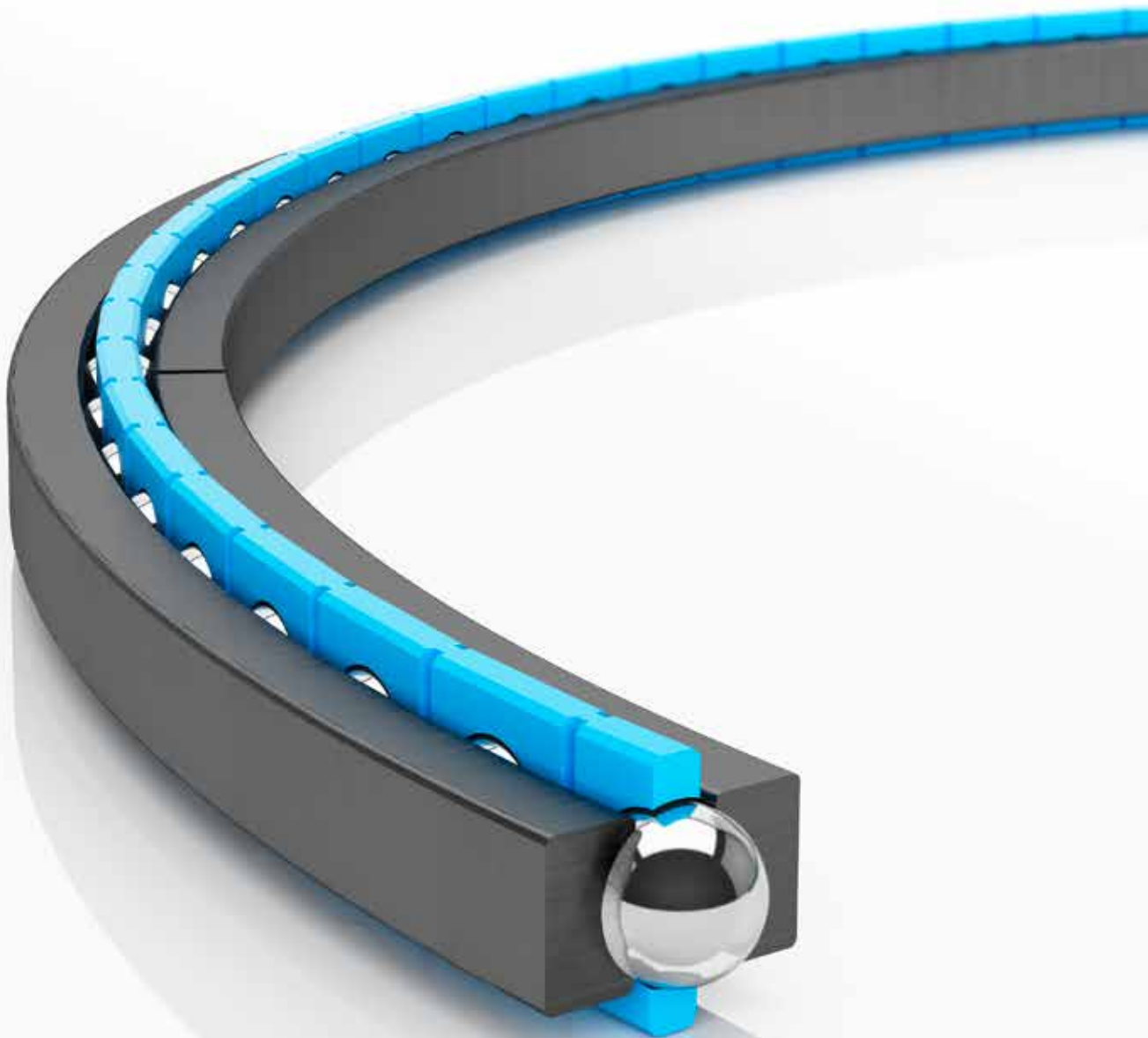

Slim Bearings

Type	Characteristic	Inner diameter	Page
LSA4	2-ring bearing/profiled raceway	3" – 15"	36–37
LSA6	2-ring bearing/profiled raceway	4.5" – 15"	36–37
LSA8	2-ring bearing/profiled raceway	5.5" – 30"	38–39
LSB3/8	Metal sleeve/ground raceway	4.75" – 25"	40–41
LSB1/2	Metal sleeve/ground raceway	6" – 25"	40–41
LSB3/4	Metal sleeve/ground raceway	7" – 25"	42–43
LSB1	Metal sleeve/ground raceway	8" – 25"	42–43



Slim Bearings

2-ring bearing/profiled raceway

Type LSA

LSA4

New

d Inch	Dimensions mm		Load rating kN				Stat. moment kNm	Weight
	D	d	C_{0a}	C_{0r}	C_a	C_f		
LSA4-3	90.20	76.20	20	9	5	5	0.4	0.04
LSA4-3.5	102.90	88.90	23	11	6	5	0.5	0.05
LSA4-4	115.60	101.60	26	12	6	5	0.7	0.05
LSA4-4.5	128.30	114.30	29	14	6	5	0.8	0.06
LSA4-5	141.00	127.00	33	15	7	6	1.0	0.07
LSA4-5.5	153.70	139.70	36	17	7	6	1.0	0.07
LSA4-6	166.40	152.40	38	18	7	6	1.0	0.08
LSA4-6.5	179.10	165.10	42	20	7	6	2.0	0.08
LSA4-7	191.80	177.80	45	21	7	6	2.0	0.09
LSA4-7.5	204.50	190.50	48	23	8	7	2.0	0.10
LSA4-8	217.20	203.20	51	24	8	7	3.0	0.10
LSA4-8.5	229.90	215.90	54	26	8	7	3.0	0.11
LSA4-9	242.60	228.60	58	27	8	7	3.0	0.12
LSA4-9.5	255.30	241.30	60	28	8	7	4.0	0.12
LSA4-10	268.00	254.00	64	30	8	7	4.0	0.13
LSA4-11	293.40	279.40	70	33	9	7	5.0	0.14
LSA4-12	318.80	304.80	76	36	9	8	6.0	0.15
LSA4-13	344.20	330.20	82	39	9	8	7.0	0.17
LSA4-14	369.60	355.60	89	42	9	8	8.0	0.18
LSA4-15	395.00	381.00	95	45	10	8	9.0	0.19

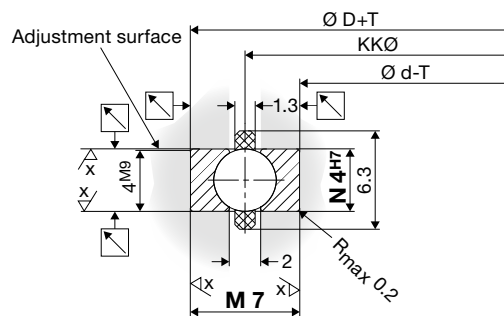

LSA6

New

d Inch	Dimensions mm		Load rating kN				Stat. moment kNm	Weight
	D	d	C_{0a}	C_{0r}	C_a	C_f		
LSA6-4.5	127.00	114.30	41	19	6	5	1	0.08
LSA6-5	139.70	127.00	44	21	6	6	1	0.09
LSA6-5.5	152.40	139.70	49	23	7	6	2	0.10
LSA6-6	165.10	152.40	53	25	7	6	2	0.11
LSA6-6.5	177.80	165.10	58	27	7	6	2	0.12
LSA6-7	190.50	177.80	62	29	7	6	3	0.13
LSA6-7.5	203.20	190.50	67	31	8	7	3	0.14
LSA6-8	215.90	203.20	70	33	8	7	3	0.15
LSA6-8.5	228.60	215.90	75	35	8	7	4	0.16
LSA6-9	241.30	228.60	79	37	8	7	4	0.16
LSA6-9.5	254.00	241.30	84	39	8	7	5	0.17
LSA6-10	266.70	254.00	88	41	8	7	5	0.18
LSA6-11	292.10	279.40	97	46	9	7	7	0.20
LSA6-12	317.50	304.80	105	49	9	8	8	0.22
LSA6-13	342.90	330.20	114	54	9	8	9	0.24
LSA6-14	368.30	355.60	123	58	9	8	10	0.25
LSA6-15	393.70	381.00	131	62	10	8	12	0.27

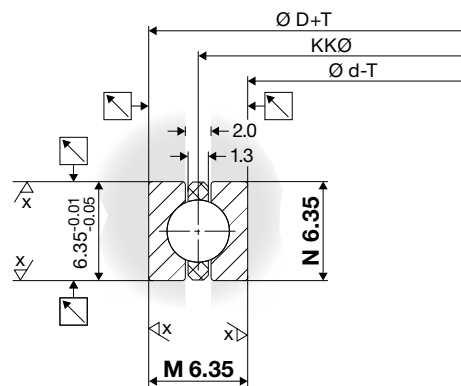

$KK\text{Ø} \leq 500 \text{ mm } T = IT6$ $KK\text{Ø} > 500 \text{ mm } T = IT7$ $\chi_y = Ra 3.2$
Available infinitely variable in all intermediate diameters.

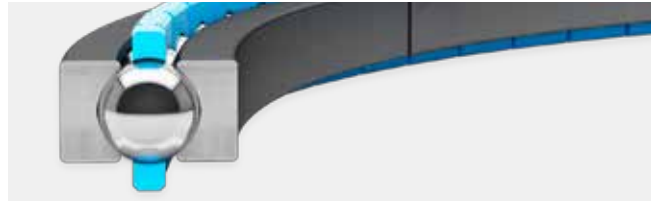

Bearing type

Franke slim bearings of type LSA deliver a convincingly smooth run, require extremely compact mounting space, ensure simple assembly and come at a favorable price.

Characteristics

Slim bearings type LSA consist of one inner and one outer race ring with hardened and profiled raceway and a plastic cage with retained balls. The rolling elements touch the race rings at two points each, hence ensuring the 4-point system. The race rings are separated; their diameter can therefore be altered elastically for mounting.

Mating structure

The bearing element mounted determines the overall construction's load bearing capacity. Hence the mating construction can be made of alternative materials such as steel, aluminium or plastic. Axial and radial accuracy (see diagram below) are defined to a substantial extent by the mating components. These properties can be enhanced by boosting the accuracy of manufacture.

Please find construction examples, special forms, special accuracies and other options of individual tailoring on pages 11–19.

Technical details

Material	Ball race rings: 54SiCr6, rolling element: 100Cr6, cage: PA12
Temperature in use	–30 °C to +80 °C, briefly up to +100 °C
Circumferential speed	max. 5 m/s, without seals max. 10 m/s
Lubricant grease	Klüber ISOFLEX TOPAS NCA52
Lubrication schedule	See 'Technical information'.
Tolerance details	See 'Technical information'.

Please find additional data on calculation, mounting and setting in 'Technical information'.



Constructive example

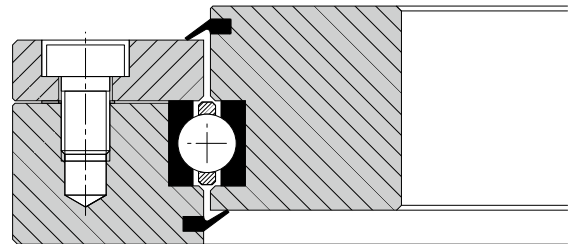

Rotational resistance

The rotational resistance indicates the preload on the bearing assembly. It is dependent on the respective type and the race ring diameter. The values indicated in the diagram are standard values and can be aligned individually.

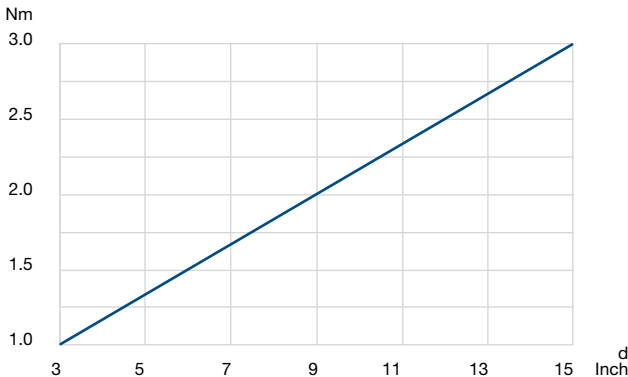

Radial and axial runout accuracy

The running accuracies indicated in the diagram are maximum values and may be improved by restricting the tolerances.

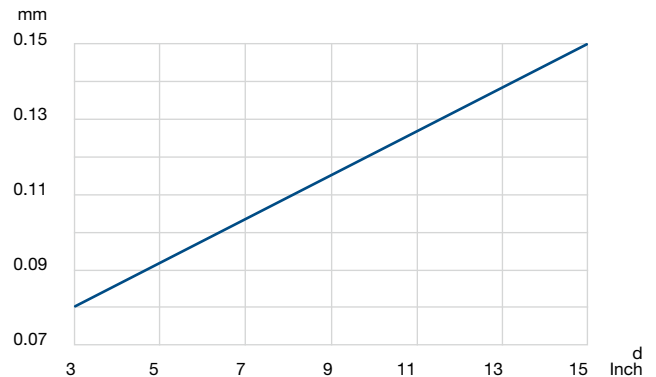

Slim Bearings

2-ring bearing/profiled raceway

Type LSA

LSA8

d Inch	Dimensions		Load rating				Stat. moment kNm	Weight
	mm D	d	C_{0a}	C_{0r}	C_a	C_f		
LSA8-5.5	155.58	139.70	55	26	10	9	2	0.13
LSA8-6	168.28	152.40	59	28	10	9	2	0.14
LSA8-6.5	180.98	165.10	65	30	11	9	3	0.16
LSA8-7	193.68	177.80	69	33	11	9	3	0.17
LSA8-7.5	206.38	190.50	76	36	11	10	4	0.18
LSA8-8	219.08	203.20	79	37	11	10	4	0.19
LSA8-8.5	231.78	215.90	84	39	12	10	4	0.20
LSA8-9	244.48	228.60	88	42	12	10	5	0.21
LSA8-9.5	257.18	241.30	93	44	12	10	5	0.22
LSA8-10	269.88	254.00	98	46	12	11	6	0.24
LSA8-11	295.28	279.40	107	50	13	11	7	0.26
LSA8-12	320.68	304.80	117	55	13	11	9	0.28
LSA8-13	346.08	330.20	126	59	13	12	10	0.30
LSA8-14	371.48	355.60	136	64	14	12	12	0.33
LSA8-15	396.88	381.00	146	69	14	12	13	0.35
LSA8-16	422.28	406.40	155	73	15	13	15	0.37
LSA8-17	447.68	431.80	165	78	15	13	17	0.39
LSA8-18	473.08	457.20	174	82	15	13	19	0.42
LSA8-19	498.48	482.60	184	87	15	13	21	0.44
LSA8-20	523.88	508.00	194	91	16	14	24	0.47
LSA8-22	574.68	558.80	213	100	16	14	28	0.52
LSA8-24	625.48	609.60	232	109	17	15	34	0.56
LSA8-26	676.28	660.40	253	119	17	15	40	0.61
LSA8-28	727.08	711.20	270	127	18	15	46	0.66
LSA8-30	777.88	762.00	294	138	18	16	54	0.71

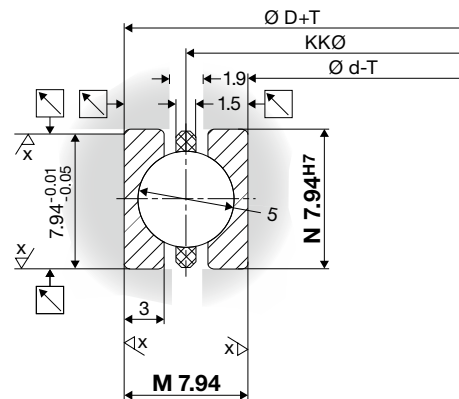

$KK\varnothing \leq 500 \text{ mm } T = IT6$
 $KK\varnothing > 500 \text{ mm } T = IT7$
 $\sqrt{R_a} = Ra 3.2$
 Available infinitely variable in all intermediate diameters.



Bearing type

Franke slim bearings of type LSA deliver a convincingly smooth run, require extremely compact mounting space, ensure simple assembly and come at a favorable price.

Characteristics

Slim bearings type LSA consist of one inner and one outer race ring with hardened and profiled raceway and a plastic cage with retained balls. The rolling elements touch the race rings at two points each, hence ensuring the 4-point system. The race rings are separated; their diameter can therefore be altered elastically for mounting.

Mating structure

The bearing element mounted determines the overall construction's load bearing capacity. Hence the mating construction can be made of alternative materials such as steel, aluminium or plastic. Axial and radial accuracy (see diagram below) are defined to a substantial extent by the mating components. These properties can be enhanced by boosting the accuracy of manufacture.

Please find construction examples, special forms, special accuracies and other options of individual tailoring on pages 11–19.

Technical details

Material	Ball race rings: 54SiCr6, rolling element: 100Cr6, cage: PA12
Temperature in use	–30 °C to +80 °C, briefly up to +100 °C
Circumferential speed	max. 5 m/s, without seals max. 10 m/s
Lubricant grease	Klüber ISOFLEX TOPAS NCA52
Lubrication schedule	See 'Technical information'.
Tolerance details	See 'Technical information'.

Please find additional data on calculation, mounting and setting in 'Technical information'.



Constructive example

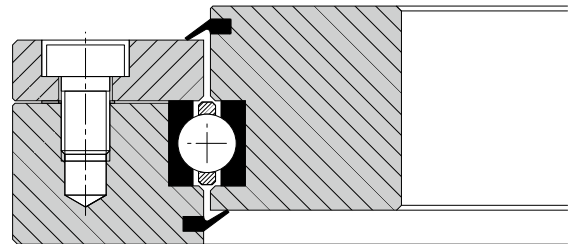

Rotational resistance

The rotational resistance indicates the preload on the bearing assembly. It is dependent on the respective type and the race ring diameter. The values indicated in the diagram are standard values and can be aligned individually.

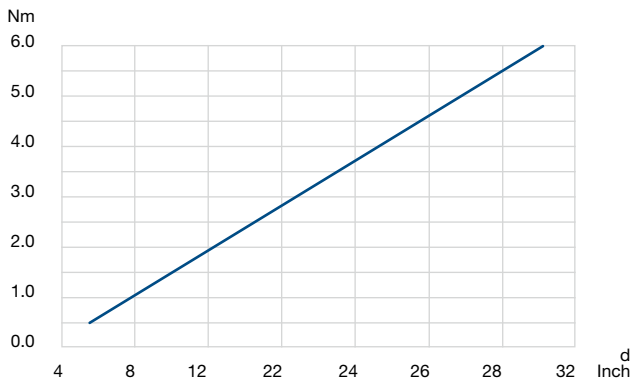

Radial and axial runout accuracy

The running accuracies indicated in the diagram are maximum values and may be improved by restricting the tolerances.

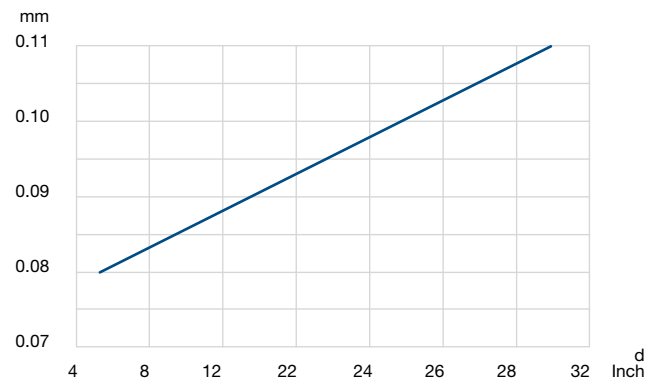

Slim Bearings

Metal sleeve/ground raceway

Type LSB

LSB3/8

d Inch	Dimensions mm		Load rating kN				Stat. moment kNm	
	D	d	C_{0a}	C_{0r}	C_a	C_r	C_{0m}	
LSB3/8-4.75	139.70	120.65	50	23	11	10	2	
LSB3/8-5	146.05	127.00	52	24	11	10	2	
LSB3/8-5.5	158.75	139.70	57	27	12	10	2	
LSB3/8-6	171.45	152.40	62	29	12	10	2	
LSB3/8-6.5	184.15	165.10	67	32	12	11	3	
LSB3/8-7	196.85	177.80	72	34	13	11	3	
LSB3/8-7.5	209.55	190.50	76	36	13	11	4	
LSB3/8-8	222.25	203.20	82	39	13	12	4	
LSB3/8-9	247.65	228.60	91	43	14	12	5	
LSB3/8-10	273.05	254.00	101	48	14	12	6	
LSB3/8-11	298.45	279.40	112	53	15	13	8	
LSB3/8-12	323.85	304.80	121	57	15	13	9	
LSB3/8-14	374.65	355.60	142	67	16	14	12	
LSB3/8-16	425.45	406.40	161	76	17	15	16	
LSB3/8-18	476.25	457.20	181	85	18	15	20	
LSB3/8-20	527.05	508.00	200	94	18	16	24	
LSB3/8-25	654.05	635.00	251	118	20	17	38	

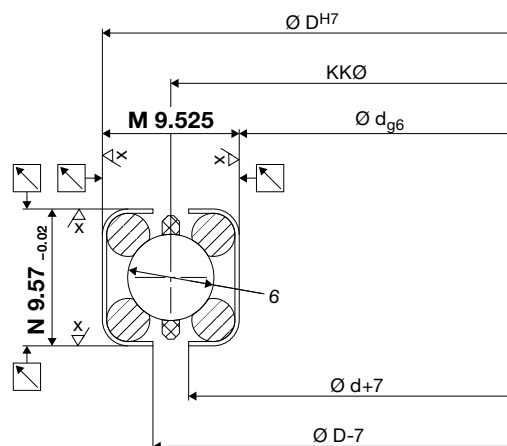

LSB1/2

d Inch	Dimensions mm		Load rating kN				Stat. moment kNm	
	D	d	C_{0a}	C_{0r}	C_a	C_r	C_{0m}	
LSB1/2-6	177.80	152.40	71	33	19	16	3	
LSB1/2-6.5	190.50	165.10	76	36	19	16	3	
LSB1/2-7	203.20	177.80	81	38	19	17	4	
LSB1/2-7.5	215.90	190.50	87	41	20	17	4	
LSB1/2-8	228.60	203.20	92	43	20	18	5	
LSB1/2-9	254.00	228.60	102	48	21	18	6	
LSB1/2-10	279.40	254.00	114	54	22	19	7	
LSB1/2-11	304.80	279.40	126	59	23	20	9	
LSB1/2-12	330.20	304.80	136	64	24	20	10	
LSB1/2-14	381.00	355.60	159	75	25	22	14	
LSB1/2-16	431.80	406.40	181	85	26	23	18	
LSB1/2-18	482.60	457.20	202	95	27	24	22	
LSB1/2-20	533.40	508.00	224	105	28	25	27	
LSB1/2-25	660.40	635.00	279	131	31	27	43	

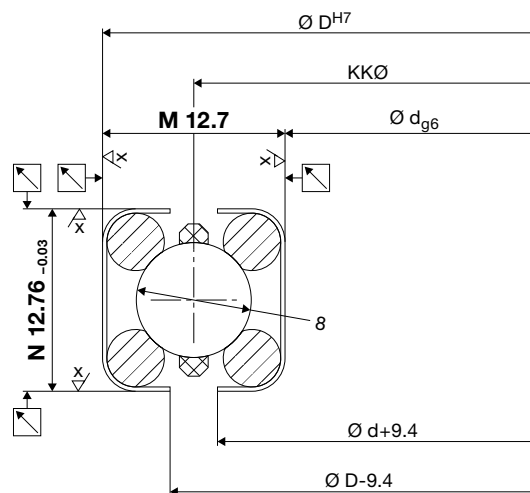

$\nabla_x = Ra 3.2$

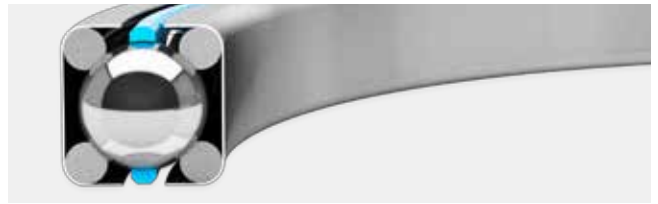

Bearing type

Franke slim bearings of type LSB consist of a bearing element type LEL with a ground raceway, embedded in two bearing sleeves made of metal. The sleeve holds the bearing together and hence permits rapid and simple assembly.

Characteristics

Slim bearings type LSB consist of two inner and outer race rings with ground raceway, one plastic cage with retained balls and a surrounding metal sleeve. The sleeves and the race rings are separated; their diameter can therefore be altered elastically for mounting. Unlike standard slim bearings, Franke slim bearings type LSB can be modified in terms of clearance/preload.

Mating structure

The greatest levels of accuracy are achieved if the constructive design of the mating parts takes place in such a way that the handling of all diameters and surfaces relating to each other can take place within in one setting. The running accuracies indicated in the diagram are average values and may be improved by restricting the tolerances (see 'Technical information').

Please find construction examples, special forms, special accuracies and other options of individual tailoring to your applications and also instructions on assembly on pages 11 – 19.

Technical details

Material	Ball race rings: 54SiCr6, rolling element: 100Cr6, cage: PA12
Temperature in use	-30 °C to +80 °C, briefly up to +100 °C
Circumferential speed	max. 5 m/s, without seals max. 10 m/s
Lubricant grease	Klüber ISOFLEX TOPAS NCA52
Lubrication schedule	See 'Technical information'.
Tolerance details	See 'Technical information'.

Please find additional data on calculation, mounting and setting in 'Technical information'.



Constructive example

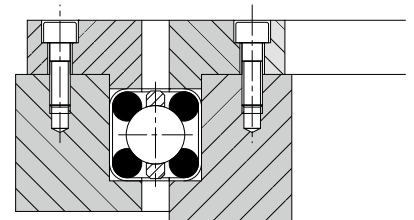

Rotational resistance

The rotational resistance indicates the preload on the bearing assembly. It is dependent on the respective type and the race ring diameter. The values indicated in the diagram are standard values and can be aligned individually.

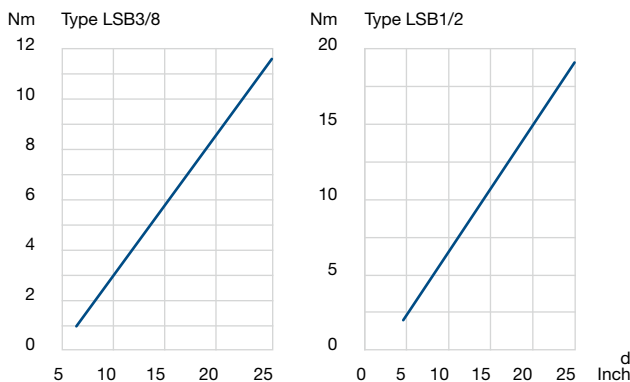

Radial and axial runout accuracy

The running accuracies indicated in the diagram are maximum values and may be improved by restricting the tolerances.

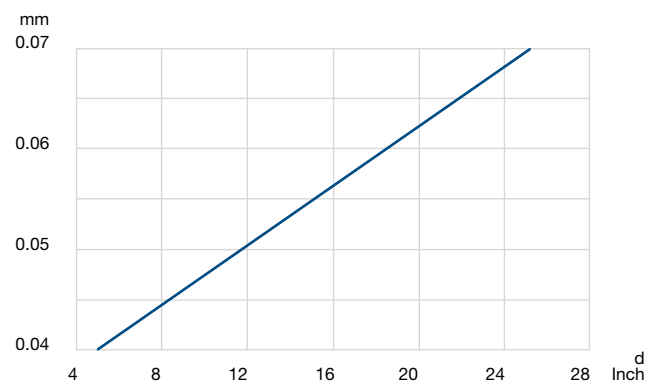

Slim Bearings

Metal sleeve/ground raceway

Type LSB

LSB3/4

d Inch	Dimensions mm		Load rating kN				Stat. moment kNm
	D	d	C_{0a}	C_{0r}	C_a	C_r	C_{0m}
LSB3/4-7	215.90	177.80	153	72	49	43	7
LSB3/4-7.5	228.60	190.50	167	79	51	44	8
LSB3/4-8	241.30	203.20	177	83	53	45	9
LSB3/4-9	266.70	228.60	197	93	55	48	11
LSB3/4-10	292.10	254.00	217	102	56	49	14
LSB3/4-11	317.50	279.40	241	113	59	51	17
LSB3/4-12	342.90	304.80	261	123	61	53	20
LSB3/4-14	393.70	355.60	300	141	64	55	26
LSB3/4-16	444.50	406.40	344	162	67	58	34
LSB3/4-18	495.30	457.20	388	183	71	61	43
LSB3/4-20	546.10	508.00	427	201	73	63	53
LSB3/4-25	673.10	635.00	530	250	79	68	82

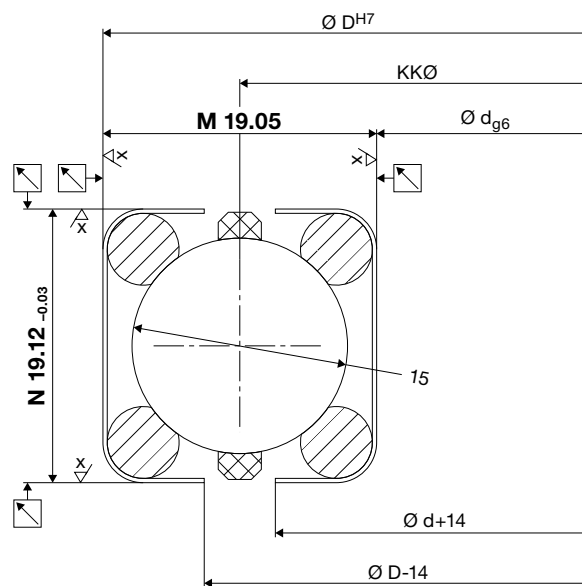

LSB1

d Inch	Dimensions mm		Load rating kN				Stat. moment kNm
	D	d	C_{0a}	C_{0r}	C_a	C_r	C_{0m}
LSB1-8	254.00	203.20	272	128	78	68	15
LSB1-9	279.40	228.60	303	142	82	71	18
LSB1-10	304.80	254.00	334	157	85	73	22
LSB1-11	330.20	279.40	365	172	88	76	26
LSB1-12	355.60	304.80	396	186	71	78	31
LSB1-14	406.40	355.60	458	216	96	83	41
LSB1-16	457.20	406.40	520	245	100	87	53
LSB1-18	508.00	457.20	582	274	105	91	66
LSB1-20	558.80	508.00	655	308	110	95	82
LSB1-25	685.80	635.00	810	381	119	103	126

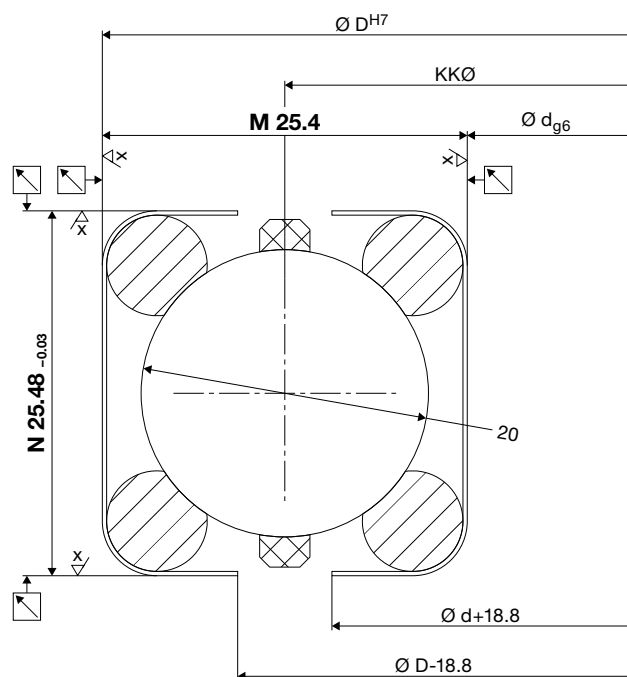

∇ = Ra 3.2

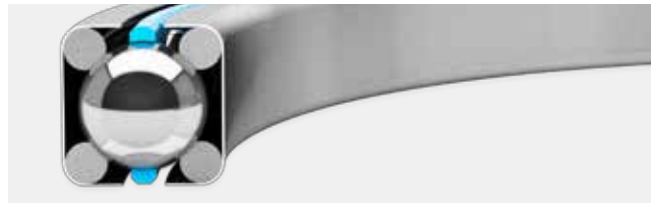

Bearing type

Franke slim bearings of type LSB consist of a bearing element type LEL with a ground raceway, embedded in two bearing sleeves made of metal. The sleeve holds the bearing together and hence permits rapid and simple assembly.

Characteristics

Slim bearings type LSB consist of two inner and outer race rings with ground raceway, one plastic cage with retained balls and a surrounding metal sleeve. The sleeves and the race rings are separated; their diameter can therefore be altered elastically for mounting. Unlike standard slim bearings, Franke slim bearings type LSB can be modified in terms of clearance/preload.

Mating structure

The greatest levels of accuracy are achieved if the constructive design of the mating parts takes place in such a way that the handling of all diameters and surfaces relating to each other can take place within in one setting. The running accuracies indicated in the diagram are average values and may be improved by restricting the tolerances (see 'Technical information').

Please find construction examples, special forms, special accuracies and other options of individual tailoring to your applications and also instructions on assembly on pages 11 – 19.

Technical details

Material	Ball race rings: 54SiCr6, rolling element: 100Cr6, cage: PA12
Temperature in use	-30 °C to +80 °C, briefly up to +100 °C
Circumferential speed	max. 5 m/s, without seals max. 10 m/s
Lubricant grease	Klüber ISOFLEX TOPAS NCA52
Lubrication schedule	See 'Technical information'.
Tolerance details	See 'Technical information'.

Please find additional data on calculation, mounting and setting in 'Technical information'.

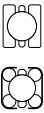

Constructive example

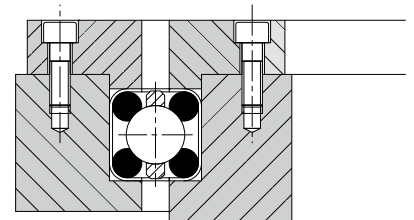

Rotational resistance

The rotational resistance indicates the preload on the bearing assembly. It is dependent on the respective type and the race ring diameter. The values indicated in the diagram are standard values and can be aligned individually.

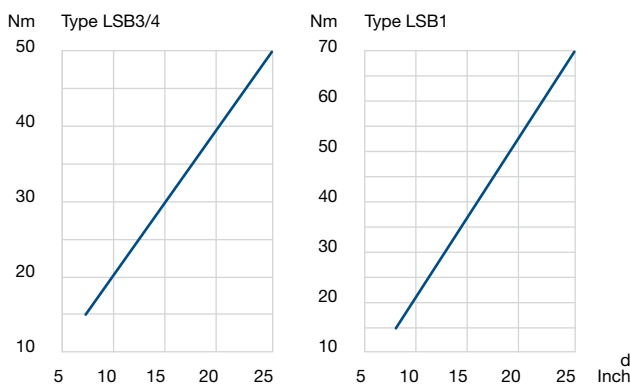

Radial and axial runout accuracy

The running accuracies indicated in the diagram are maximum values and may be improved by restricting the tolerances.

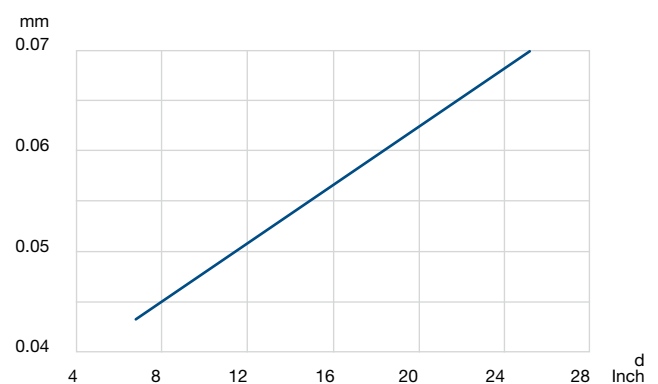



Bearing Assemblies

Type	Characteristic	KKØ	Page
LVA	Steel design	100–1800	46–47
LVB	Aluminium design	100–1800	48–49
LVC	Angular contact ball bearing/steel design	100–1800	50–51
LVD	Steel design/external gear type	100–1800	52–53
LVE	Aluminium design/toothed belt gear type	100–1800	54–55



Bearing Assemblies

Steel design

Type LVA

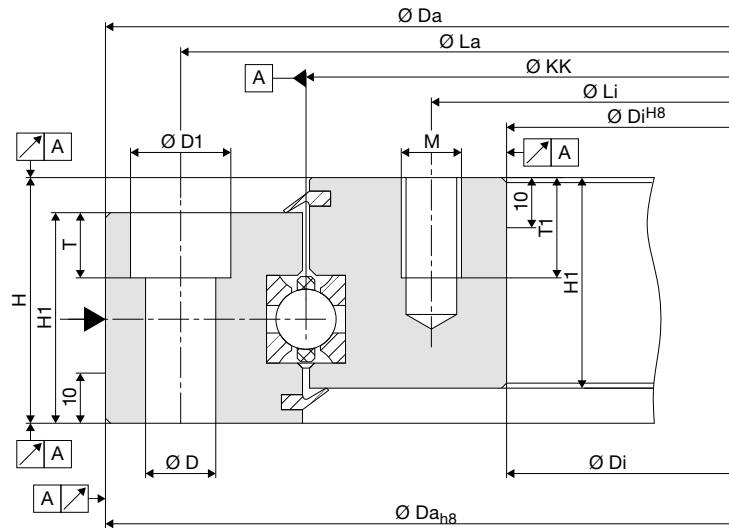

KKØ mm	Dimensions						
	D1	D	H	H1	T	M	T1
100-250	11	6.6	34 ^{+/-04}	27	6.8	M 6	10
300-350	15	9.0	38 ^{+/-04}	31	9.0	M 8	15
400-450	18	11.0	44 ^{+/-05}	37	11.0	M 10	15
500-600	20	14.0	49 ^{+/-05}	42	13.0	M 12	20
700-1000	20	14.0	53 ^{+/-05}	45	13.0	M 12	25
1200-1400	26	18.0	60 ^{+/-05}	52	17.5	M 16	25
1600-1800	26	18.0	90 ^{+/-05}	82	17.5	M 16	25

KKØ mm	Dimensions				Fixing/ mounting per ring	Load rating				Stat. moment kNm	Weight kg	Availability
	Da _{H8}	Di ^{H8}	La	Li		C _{0a}	C _{0r}	C _a	C _r			
LVA0100	150	50	135	65	6x	54	25	18	16	1	3.0	from stores
LVA0150	200	100	185	115	6x	82	39	22	19	3	4.6	
LVA0200	250	150	235	165	8x	110	52	24	21	5	6.1	from stores
LVA0250	300	200	285	215	10x	138	65	26	23	8	7.6	
LVA0300	360	240	340	260	12x	166	78	28	24	12	12.8	from stores
LVA0350	410	290	390	310	14x	196	92	30	26	16	15.0	
LVA0400	470	330	445	355	14x	424	199	54	47	40	23.7	from stores
LVA0450	520	380	495	405	14x	477	224	57	49	57	26.7	
LVA0500	580	420	550	450	14x	530	249	59	51	62	39.1	from stores
LVA0600	680	520	650	550	16x	635	299	63	54	63	46.9	from stores
LVA0700	790	610	750	650	22x	746	351	67	58	123	66.5	
LVA0800	890	710	850	750	24x	852	401	70	61	160	76.0	
LVA0900	990	810	950	850	24x	958	451	73	63	203	85.6	
LVA1000	1090	910	1050	950	26x	1068	503	76	66	251	95.0	
LVA1200	1300	1100	1265	1135	30x	1573	740	98	85	444	114.8	
LVA1400	1500	1300	1465	1335	36x	1835	864	104	90	604	169.0	
LVA1600	1730	1470	1685	1515	42x	2105	991	109	95	793	399.0	
LVA1800	1930	1670	1885	1715	46x	2367	1114	114	99	1003	449.0	

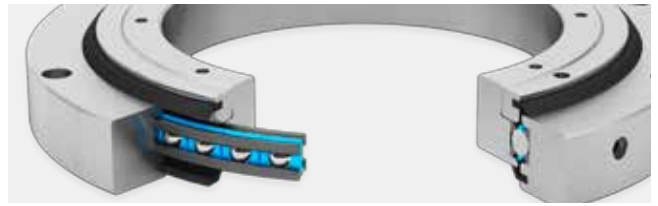

Bearing type

LVA is a bearing assembly with housing rings made of steel and integrated bearing element. Franke bearing assemblies in type LVA are designed for medium rotational speeds and accuracies. They are available on short notice, in some cases even from the warehouse (see table).

Characteristics

Franke bearing assemblies type LVA are ready-to-use, complete bearings with integrated Wire Race Bearings. Designed as 4-point bearings, they absorb equal load from all sides and are insensitive to impact and vibration. The bearing assemblies are sealed on both sides and set free from clearance and are preloaded. On request you can receive the bearing assemblies ex works with your specified preload values.

Please find construction examples, special accuracies and other options of individual tailoring on pages 11–19.

Technical details

Material	Inner/outer ring: C45N, ball race rings: 54SiCr6, rolling element: 100Cr6, cage: PA12, seal: NBR
Temperature in use	-30 °C to +80 °C, briefly up to +100 °C
Circumferential speed	max. 5 m/s, without seals max. 10 m/s
Screw connection	See 'Technical information'.
Lubricant grease	Klüber ISOFLEX TOPAS NCA52
Relubrication	using grease nipples according to DIN 3405
Lubrication schedule	See 'Technical information'.



Technical information/calculation

Please find additional information on bearing selection, calculation, mounting and setting in 'Technical information'. Our technical consultants are pleased to assist you in identifying the correct bearing assembly for your application.

Please call us under: +49 7361 920-0 or send us an email at: info@franke-gmbh.de.

Rotational resistance

The rotational resistance indicates the preload on the bearing assembly. It is dependent on the respective type and the race ring diameter. The values indicated in the diagram are standard values and can be aligned individually.

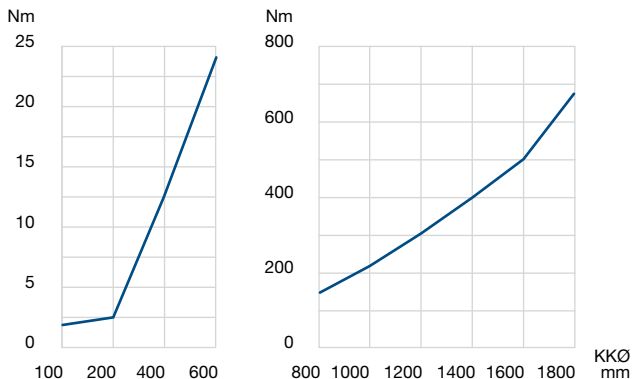

Radial and axial runout accuracy

The running accuracies in the diagram are maximum values.

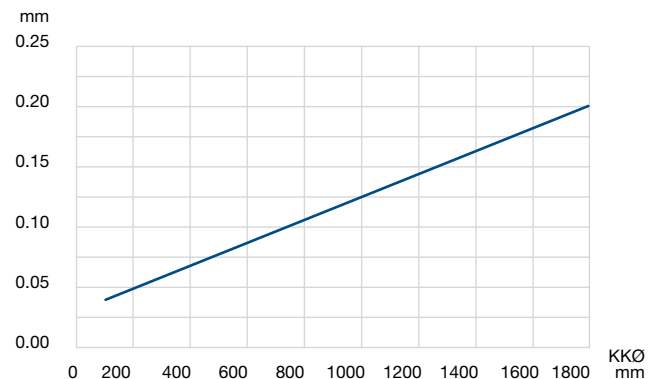

Bearing Assemblies

Aluminium design

Type LVB

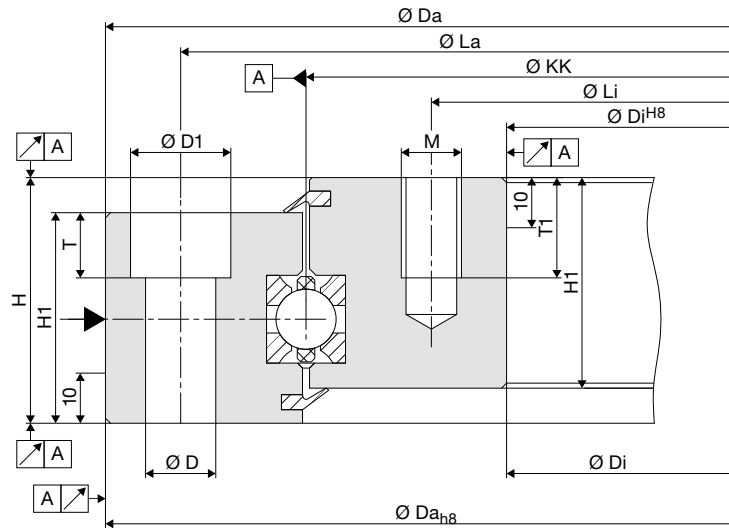

KKØ mm	Dimensions						
	D1	D	H	H1	T	M	T1
100–250	11	6.6	34 ^{+/-04}	27	6.8	M 6	10
300–350	15	9.0	38 ^{+/-04}	31	9.0	M 8	15
400–450	18	11.0	44 ^{+/-05}	37	11.0	M 10	15
500–600	20	14.0	49 ^{+/-05}	42	13.0	M 12	20
700–1000	20	14.0	53 ^{+/-05}	45	13.0	M 12	25
1200–1400	26	18.0	60 ^{+/-05}	52	17.5	M 16	25
1600–1800	26	18.0	90 ^{+/-05}	82	17.5	M 16	25

KKØ mm	Dimensions				Fixing/ mounting per ring	Load rating				Stat. moment kNm	Weight kg	Availability
	Da_{H8}	Di^{H8}	La	Li		C_{0a}	C_{0r}	C_a	C_f			
LVB0100	150	50	135	65	6x	54	25	18	16	1	1.2	from stores
LVB0150	200	100	185	115	6x	82	39	22	19	3	1.8	
LVB0200	250	150	235	165	8x	110	52	24	21	5	2.4	from stores
LVB0250	300	200	285	215	10x	138	65	26	23	8	3.0	
LVB0300	360	240	340	260	12x	166	78	28	24	12	4.9	from stores
LVB0350	410	290	390	310	14x	196	92	30	26	16	5.8	
LVB0400	470	330	445	355	14x	424	199	54	47	40	9.5	
LVB0450	520	380	495	405	14x	477	224	57	49	57	10.6	
LVB0500	580	420	550	450	14x	530	249	59	51	62	15.1	
LVB0600	680	520	650	550	16x	635	299	63	54	63	18.2	
LVB0700	790	610	750	650	22x	746	351	67	58	123	25.5	
LVB0800	890	710	850	750	24x	852	401	70	61	160	29.1	
LVB0900	990	810	950	850	24x	958	451	73	63	203	32.8	
LVB1000	1090	910	1050	950	26x	1068	503	76	66	251	36.4	
LVB1200	1300	1100	1265	1135	30x	1573	740	98	85	444	56.0	
LVB1400	1500	1300	1465	1335	36x	1835	864	104	90	604	65.3	
LVB1600	1730	1470	1685	1515	42x	2105	991	109	95	793	148.2	
LVB1800	1930	1670	1885	1715	46x	2367	1114	114	99	1003	166.7	

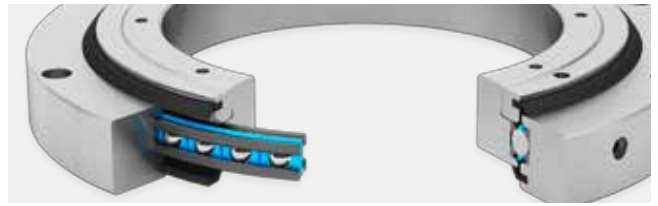

Bearing type

LVB is a bearing assembly with housing rings made of aluminium and integrated bearing element. Franke bearing assemblies in type LVB are designed for medium rotational speeds and accuracies. They are available on short notice, in some cases even from the warehouse (see table).

Characteristics

Franke bearing assemblies type LVB are ready-to-use, complete bearings with integrated Wire Race Bearings. Designed as 4-point bearings, they absorb equal load from all sides and are insensitive to impact and vibration. The bearing assemblies are sealed on both sides and set free from clearance and are preloaded. On request you can receive the bearing assemblies ex works with your specified preload values.

Please find construction examples, special accuracies and other options of individual tailoring on pages 11–19.

Technical details

Material	Inner/outer ring: AlZnMgCu05, ball race rings: 54SiCr6, rolling element: 100Cr6, cage: PA12, seal: NBR
Temperature in use	-30 °C to +80 °C, briefly up to +100 °C
Circumferential speed	max. 5 m/s, without seals max. 10 m/s
Screw connection	See 'Technical information' on p. XY
Lubricant grease	Klüber ISOFLEX TOPAS NCA52
Relubrication	using grease nipples according to DIN 3405
Lubrication schedule	See 'Technical information'.



Technical information/calculation

Please find additional information on bearing selection, calculation, mounting and setting in 'Technical information'. Our technical consultants are pleased to assist you in identifying the correct bearing assembly for your application.

Please call us under: +49 7361 920-0 or send us an email at: info@franke-gmbh.de.

Rotational resistance

The rotational resistance indicates the preload on the bearing assembly. It is dependent on the respective type and the race ring diameter. The values indicated in the diagram are standard values and can be aligned individually.

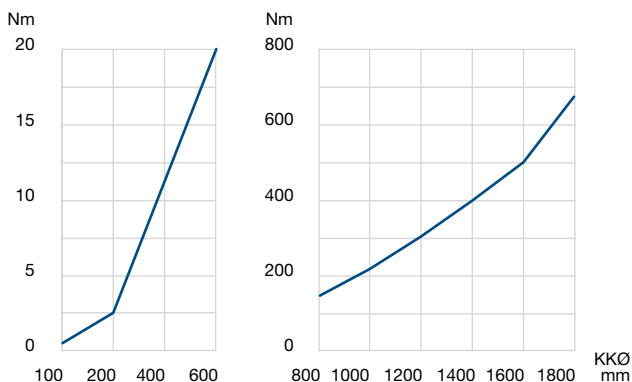

Radial and axial runout accuracy

The running accuracies in the diagram are maximum values.

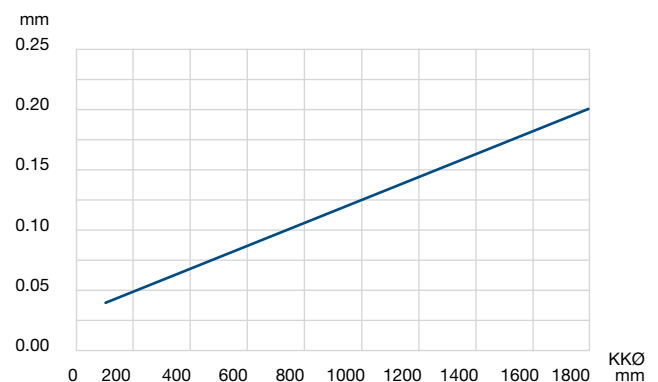

Bearing Assemblies

Angular contact ball bearings/steel design

Type LVC

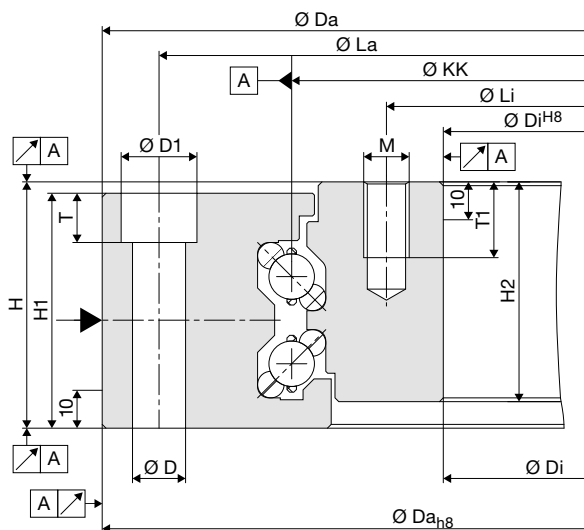

KKØ mm	Dimensions								
	D1	D	H	H1	T	M	T1	H2	
100–250	15	9	48	45	9.0	M 8	15	41	
300–450	18	11	57	54	11.0	M 10	15	50	
500–1000	20	14	65	62	13.0	M 12	20	58	
1200–1400	26	18	69	67	17.5	M 16	25	61	
1600–1800	26	18	84	82	17.5	M 16	25	76	

KKØ mm	Dimensions				Fixing/ mounting per ring	Load rating				Stat. moment	Weight
	$D_{a_{H8}}$	D_i^{H8}	L_a	L_i		kN				kNm	kg
					C_{0a}	C_{0r}	C_a	C_r	C_{0m}		
LVC0100	170	40	150	60	6x	51	24	11	10	1	7.0
LVC0150	220	90	200	110	6x	80	38	13	11	3	10.0
LVC0200	270	140	250	160	8x	146	69	22	19	7	13.4
LVC0250	320	190	300	210	10x	183	86	24	20	11	16.6
LVC0300	380	230	355	255	12x	235	111	29	25	17	27.7
LVC0350	430	280	405	305	14x	278	131	31	27	23	32.2
LVC0400	480	330	455	355	14x	318	150	33	28	30	36.7
LVC0450	530	380	505	405	14x	357	168	34	27	38	41.2
LVC0500	600	420	570	450	14x	680	320	62	54	80	63.7
LVC0600	700	520	670	550	16x	816	384	67	58	115	76.2
LVC0700	800	620	770	650	22x	958	451	71	61	158	88.6
LVC0800	900	720	870	750	24x	1094	515	74	64	206	101.1
LVC0900	1000	820	970	850	24x	1230	579	78	67	261	113.6
LVC1000	1100	920	1070	950	26x	1372	646	81	70	323	126.0
LVC1200	1300	1085	1265	1130	30x	1644	774	86	75	464	192.6
LVC1400	1500	1285	1465	1330	36x	1922	905	91	79	633	224.7
LVC1600	1730	1470	1685	1515	42x	2200	1036	96	83	828	389.0
LVC1800	1930	1670	1885	1715	46x	2472	1163	100	87	1047	437.4



Bearing type

LVC is a bearing assembly designed as double-row angular contact ball bearing made of steel with two integrated bearing elements. Franke bearing assemblies in type LVC are suitable for the highest circumferential speeds. Convincing aspects include their high dynamism and low rotational resistance.

Characteristics

Franke bearing assemblies type LVC are ready-to-use, complete bearings. The double-row angular contact ball bearing in 4-point adjustment is preloaded free of clearance. It is insensitive to impact and vibration. The low rotational resistance and the minimal breakaway torque reduce the necessary drive power. Bearing assemblies type LVC operate practically without maintenance and achieve a high service life due to the low friction values.

Please find construction examples, special accuracies and other options of individual tailoring on pages 11–19.

Technical details

Material	Inner/outer ring: C45N, ball race rings: 54SiCr6, rolling element: 100Cr6, cage: PA12
Temperature in use	-30 °C to +80 °C, briefly up to +100 °C
Circumferential speed	max. 20 m/s
Screw connection	See 'Technical information'.
Lubricant grease	Klüber ISOFLEX TOPAS NCA52
Relubrication	using grease nipples according to DIN 3405
Lubrication schedule	See 'Technical information'.



Technical information/calculation

Please find additional information on bearing selection, calculation, mounting and setting in 'Technical information'. Our technical consultants are pleased to assist you in identifying the correct bearing assembly for your application.

Please call us under: +49 7361 920-0 or send us an email at: info@franke-gmbh.de.

Rotational resistance

The rotational resistance indicates the preload on the bearing assembly. It is dependent on the respective type and the race ring diameter. The values indicated in the diagram are standard values and can be aligned individually.

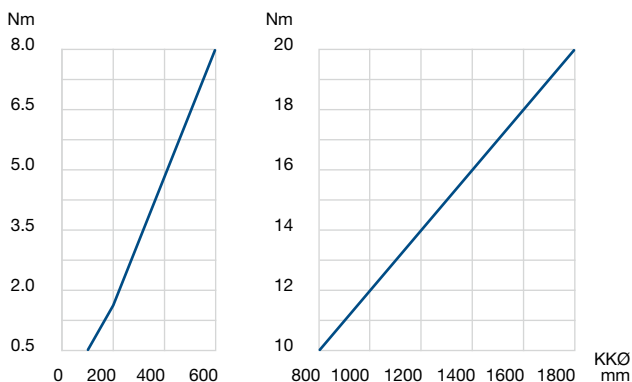

Radial and axial runout accuracy

The running accuracies in the diagram are maximum values.

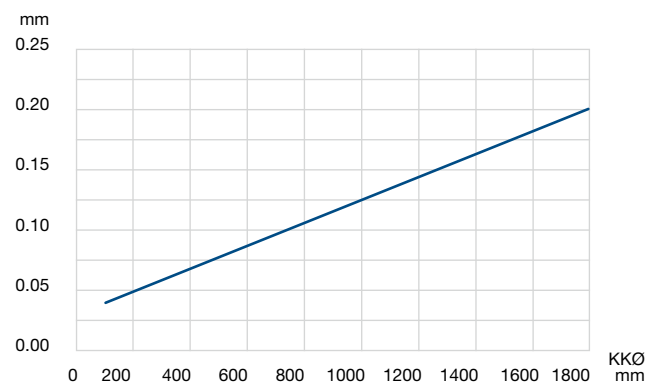

Bearing Assemblies

Steel design/external gear type

Type LVD

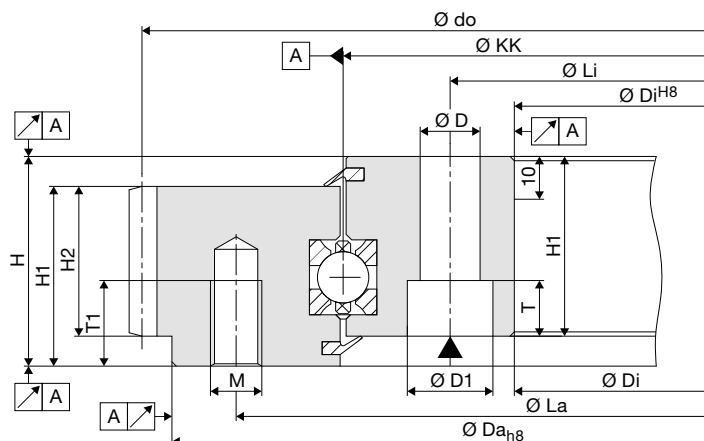

KKØ mm	Dimensions								
	D1	D	H	H1	T	M	T1	H2	
100–250	11	6.6	34 ^{+/-04}	27	6.8	M 6	10	22	
300–350	15	9.0	38 ^{+/-04}	31	9.0	M 8	15	26	
400–450	18	11.0	44 ^{+/-05}	37	11.0	M 10	15	32	
500–600	20	14.0	49 ^{+/-05}	42	13.0	M 12	20	35	
700–1000	20	14.0	53 ^{+/-05}	45	13.0	M 12	20	38	
1200–1400	26	18.0	60 ^{+/-05}	52	17.5	M 16	25	44	
1600–1800	26	18.0	90 ^{+/-05}	82	17.5	M 16	25	69	

KKØ mm	Dimensions					Fixing/ mounting per ring	Load rating				Stat. moment kNm C_{0m}	Gear		Weight kg	Availability
	Da_{H8}	Di^{H8}	La	Li	d_0		C_{0a}	C_{0r}	C_a	C_r		Module m	No. of teeth		
LVD0100	150	50	135	65	160	6x	54	25	18	16	1	2	80	3.4	
LVD0150	200	100	185	115	210	6x	82	39	22	19	3	2	105	5.0	
LVD0200	250	150	235	165	260	8x	110	52	24	21	5	2	130	6.7	from stores
LVD0250	300	200	285	215	310	10x	138	65	26	23	8	2	155	8.4	
LVD0300	360	240	340	260	372	12x	166	78	28	24	12	3	124	14.1	from stores
LVD0350	410	290	390	310	423	14x	196	92	30	26	16	3	141	16.5	
LVD0400	470	330	445	355	483	14x	424	199	54	47	40	3	161	26.0	from stores
LVD0450	520	380	495	405	554	14x	477	224	57	49	57	3	178	29.2	
LVD0500	580	420	550	450	594	14x	530	249	59	51	62	3	198	42.4	
LVD0600	680	520	650	550	693	16x	635	299	63	54	63	3	231	50.8	
LVD0700	790	610	750	650	808	22x	746	351	67	58	123	4	202	73.0	
LVD0800	890	710	850	750	920	24x	852	401	70	61	160	5	184	83.2	
LVD0900	990	810	950	850	1020	24x	958	451	73	63	203	5	204	93.6	
LVD1000	1090	910	1050	950	1120	26x	1068	503	76	66	251	5	224	104.0	
LVD1200	1300	1100	1265	1135	1320	30x	1573	740	98	85	444	5	264	158.5	
LVD1400	1500	1300	1465	1335	1520	36x	1835	864	104	90	604	5	304	184.9	
LVD1600	1730	1470	1685	1515	1732	42x	2105	991	109	95	793	6	292	430.6	
LVD1800	1930	1670	1885	1715	1956	46x	2367	1114	114	99	1003	6	326	484.2	

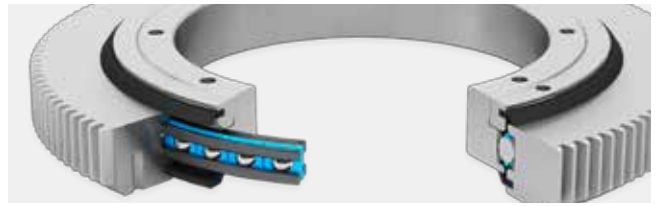

Bearing type

LVD is a bearing assembly with external gear type and housing rings made of steel and integrated bearing element. Franke bearing assemblies in type LVD are designed for medium rotational speeds and accuracies. They are available on short notice, in some cases even from the warehouse (see table).

Characteristics

Franke bearing assemblies type LVD are ready-to-use, complete bearings with integrated Wire Race Bearings. Designed as 4-point bearings, they absorb equal load from all sides and are insensitive to impact and vibration. The bearing assemblies are sealed on both sides and set free from clearance and are preloaded. On request you can receive the bearing assemblies ex works with your specified preload values.

Please find construction examples, special accuracies and other options of individual tailoring on pages 11 – 19.

Technical details

Material	Inner ring: C45N, outer ring: 42CrMo4V, ball race rings: 54SiCr6, rolling element: 100Cr6, cage: PA12, seal: NBR
Gear	DIN 3967, quality 8e25
Temperature in use	-30 °C to +80 °C, briefly up to +100 °C
Circumferential speed	max. 5 m/s, without seals max. 10 m/s
Screw connection	See 'Technical information'.
Lubricant grease	Klüber ISOFLEX TOPAS NCA52
Relubrication	using grease nipples according to DIN 3405
Lubrication schedule	See 'Technical information'.



Technical information/calculation

Please find additional information on bearing selection, calculation, mounting and setting in 'Technical information'. Our technical consultants are pleased to assist you in identifying the correct bearing assembly for your application.

Please call us under: +49 7361 920-0 or send us an email at: info@franke-gmbh.de.

Rotational resistance

The rotational resistance indicates the preload on the bearing assembly. It is dependent on the respective type and the race ring diameter. The values indicated in the diagram are standard values and can be aligned individually.

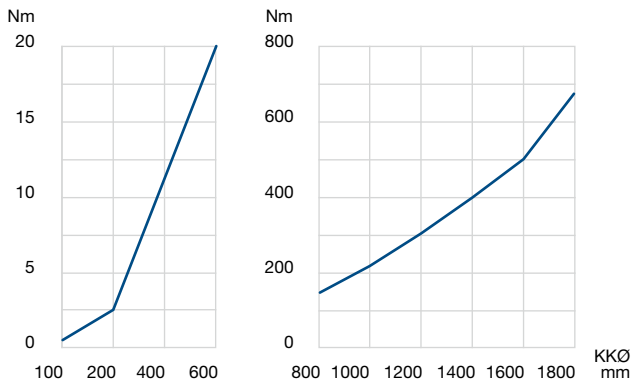

Radial and axial runout accuracy

The running accuracies in the diagram are maximum values.

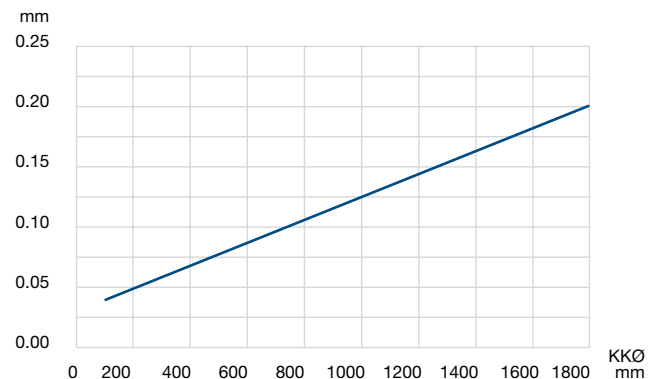

Bearing Assemblies

Aluminium design/toothed belt gear type

Type LVE

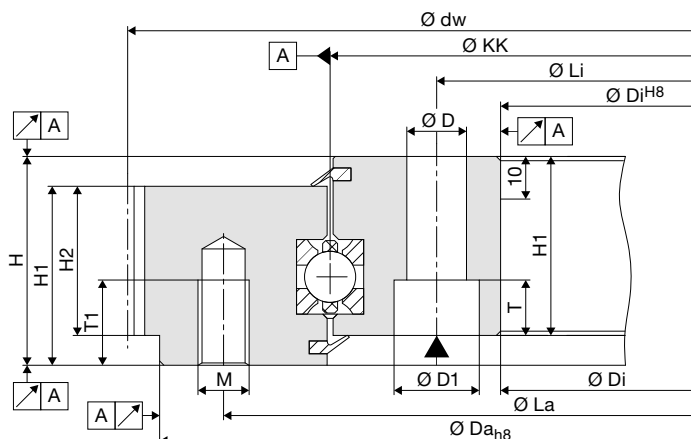

KKØ mm	Dimensions								
	D1	D	H	H1	T	M	T1	H2	
100–250	11	6.6	34 ^{+/-04}	27	6.8	M 6	10	22	
300–350	15	9.0	38 ^{+/-04}	31	9.0	M 8	15	26	
400–450	18	11.0	44 ^{+/-05}	37	11.0	M 10	15	32	
500–600	20	14.0	49 ^{+/-05}	42	13.0	M 12	20	35	
700–1000	20	14.0	53 ^{+/-05}	45	13.0	M 12	25	38	
1200–1400	26	18.0	60 ^{+/-05}	52	17.5	M 16	25	44	
1600–1800	26	18.0	90 ^{+/-05}	82	17.5	M 16	25	69	

KKØ mm	Dimensions				Fixing/ mounting per ring	Load rating				Stat. moment kNm C_{Om}	Effective range diameter dw				Weight
	Da_{H8}	Di^{H8}	La	Li		C_{Da}	C_{Or}	C_a	C_f		mm T10/AT10	z	mm HTD8	z	
LVE0100	150	50	135	65	6x	54	25	18	16	1	165.52	52	165.52	65	3.40
LVE0150	200	100	185	115	6x	82	39	22	19	3	216.45	68	213.90	84	5.00
LVE0200	250	150	235	165	8x	110	52	24	21	5	264.20	83	264.83	104	6.70
LVE0250	300	200	285	215	8x	138	65	26	23	8	324.68	102	323.40	127	8.40
LVE0300	360	240	340	260	12x	166	78	28	24	12	378.79	119	376.88	148	14.10
LVE0350	410	290	390	310	14x	196	92	30	26	16	429.72	135	430.36	169	16.50
LVE0400	470	330	445	355	14x	224	106	32	28	20	490.20	154	488.92	192	26.00
LVE0450	520	380	495	405	14x	252	120	34	30	25	541.13	170	539.85	212	29.20
LVE0500	580	420	550	450	14x	280	134	36	32	30	598.42	188	598.42	235	42.40
LVE0600	680	520	650	550	16x	330	158	38	34	35	700.28	220	697.74	274	50.80
LVE0700	790	610	750	650	22x	380	182	40	36	40	814.87	256	814.87	320	73.00
LVE0800	890	710	850	750	24x	430	206	42	38	45	929.47	292	926.92	364	83.20
LVE0900	990	810	950	850	24x	480	230	44	40	50	1028.14	323	1028.78	404	93.60
LVE1000	1090	910	1050	950	26x	530	254	46	42	55	1126.82	354	1128.09	443	104.00
LVE1200	1300	1100	1265	1135	30x	630	302	50	46	65	1330.54	418	1329.26	522	158.50
LVE1400	1500	1300	1465	1335	36x	730	350	54	50	80	1527.89	480	1527.89	600	184.90
LVE1600	1730	1470	1685	1515	42x	830	400	58	54	95	1763.44	554	1762.16	692	430.60
LVE1800	1930	1670	1885	1715	46x	930	450	62	58	100	1967.16	618	1965.88	772	848.20

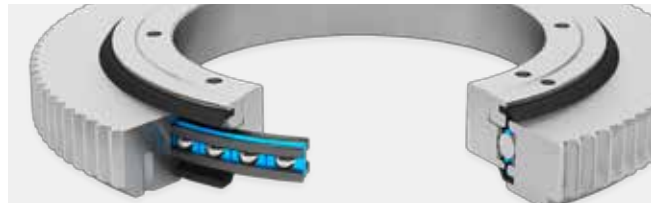

Bearing type

LVE is a bearing assembly with toothed belt gear type and housing rings made of aluminium and integrated bearing element. Franke bearing assemblies in type LVE are designed for medium rotational speeds and accuracies. They are available on short notice, in some cases even from the warehouse (see table).

Characteristics

Franke bearing assemblies type LVE are ready-to-use, complete bearings with integrated Wire Race Bearings. Designed as 4-point bearings, they absorb equal load from all sides and are insensitive to impact and vibration. The bearing assemblies are sealed on both sides and set free from clearance and are preloaded. On request you can receive the bearing assemblies ex works with your specified preload values.

Please find construction examples, special accuracies and other options of individual tailoring on pages 11 – 19.

Technical details

Material	Inner/outer ring: AlZnMgCu05, ball race rings: 54SiCr6, rolling element: 100Cr6, cage: PA12, seal: NBR
Gear	Profile T10, AT10 or HTD8
Temperature in use	-30 °C to +80 °C, briefly up to +100 °C
Circumferential speed	max. 5 m/s, without seals max. 10 m/s
Screw connection	See 'Technical information'.
Lubricant grease	Klüber ISOFLEX TOPAS NCA52
Relubrication	using grease nipples according to DIN 3405
Lubrication schedule	See 'Technical information'.



Technical information/calculation

Please find additional information on bearing selection, calculation, mounting and setting in 'Technical information'. Our technical consultants are pleased to assist you in identifying the correct bearing assembly for your application.

Please call us under: +49 7361 920-0 or send us an email at: info@franke-gmbh.de.

Rotational resistance

The rotational resistance indicates the preload on the bearing assembly. It is dependent on the respective type and the race ring diameter. The values indicated in the diagram are standard values and can be aligned individually.

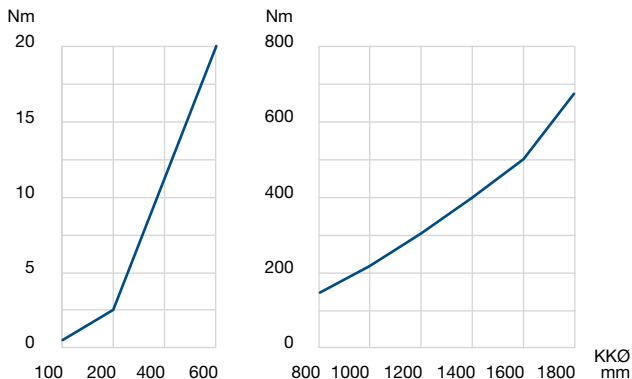

Radial and axial runout accuracy

The running accuracies in the diagram are maximum values.

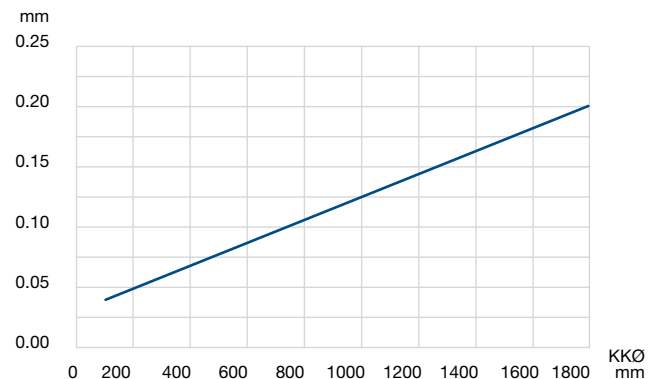

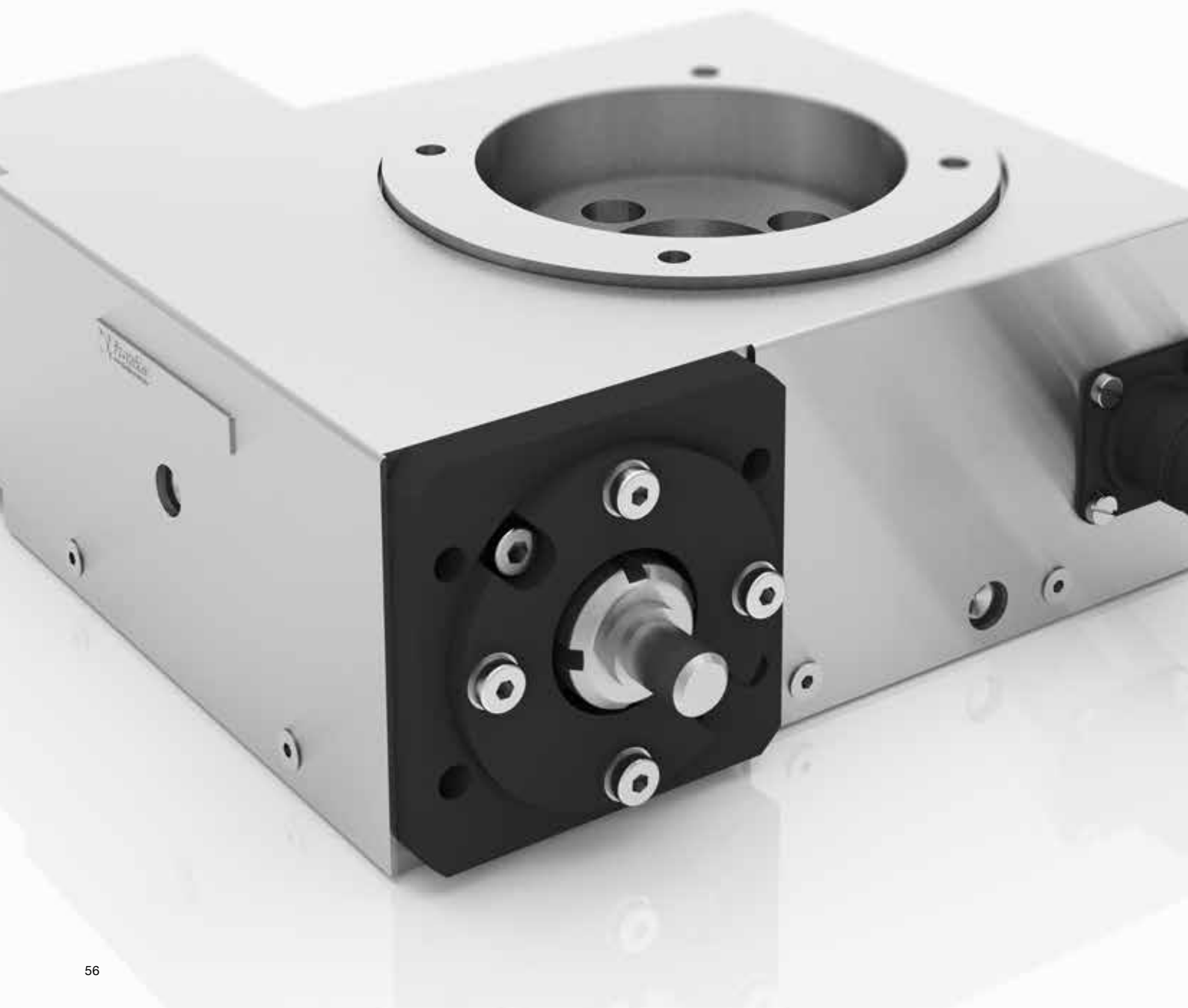

Rotary Tables

Type	Characteristic	KKØ	Page
LTA	Worm drive/highly dynamic	100, 200	58–59
LTB	Worm drive/highly accurate	125, 175	60–61



Rotary Tables

Worm drive/highly dynamic

Type LTA

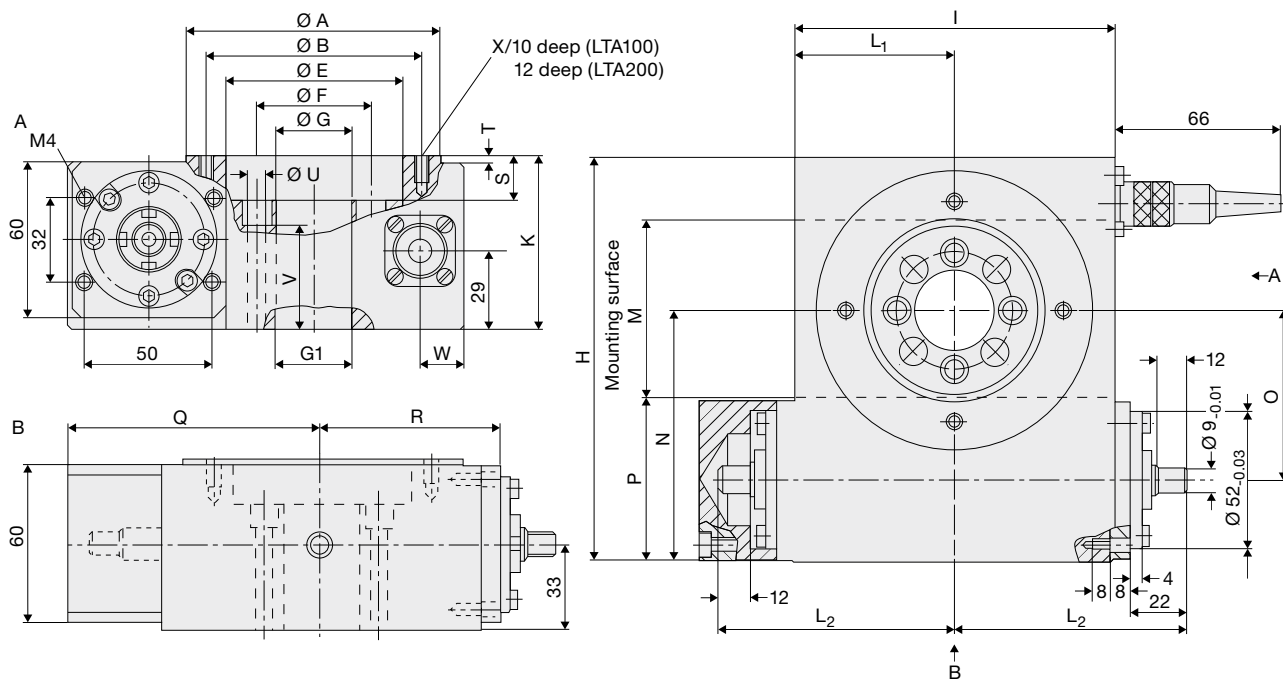

► Grease nipples according to DIN 3405

Rated Ø	Load rating		Overturning moment	Input speed	Reduction ratio	Output speed	Input torque	Output torque	Weight	Order no.
mm	kN	C	Nm	rpm	i	rpm	Nm	Nm	kg	
A	C ₀	C	C _{0m}	N _{1 max}		N _{2 max}	M _{1 max}	M _{2 max}		
100	17.5	9	289	1800	18	100	5	54	5.5	91800A
200	43.0	18	433	2200	36	61	5	108	10.0	91801A

Rated Ø																						
A	B	ØE ^{H7/} _{6 low}	ØF	ØG	ØG ₁ ^{H7/} _{12 low}	H	I	K	L ₁	L ₂	M	N	O	P	Q	R	S	T	U	V	W	X
100	85	70	45	30	30	155	125	65	62.5	91.5	70	96.0	65.0	61	99.5	69.5	17	2	4xØ6.6	39	17	4xM6
200	175	160	130	110	110	255	220	70	110.0	139.0	165	145.5	114.5	63	147.0	117.0	22	7	6xØ9.0	39	22	6xM8

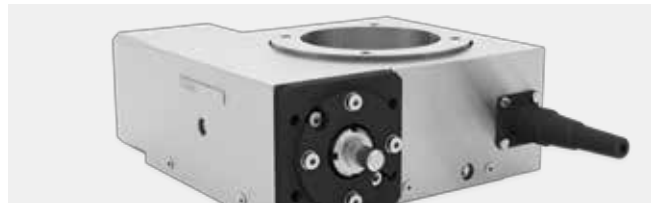

Characteristics

Franke rotary tables of type LTA are lightweight, compact, ready-to-use positioning units. They are highly resilient and deliver outstanding radial and axial run accuracy. Franke rotary tables type LTA are versatile in use and are well-suited to light processing applications and also for dynamic handling and assembly applications.

Material

Baseplate	Aluminium
Housing	V2A
Ball race rings	54SiCr6
Rolling element	100Cr6
Worm wheel	Wear-resistant bronze alloy
Worm shaft	CK45N hardened and ground

Accuracies	LTA100	LTA200
Radial and axial run accuracy	30 µm	30 µm
Positioning accuracy in arc seconds	160 sec	120 sec
Repeatability in arc seconds	20 sec	14 sec

Technical details

Reduction ratio	18:1 (LTA100), 36:1 (LTA200)
Operating temperature	-10 °C to +80 °C
Rotational speed	max. 100 min ⁻¹
Mounting position	any, but we recommend positions in which the drive module occupies the lowest point.
Lubrication	with bearing grease via grease nipples
Optional	Inductive proximity switch, flange/coupling to mount the motor, motorization



Rotary Tables

Worm drive/highly accurate

Type LTB

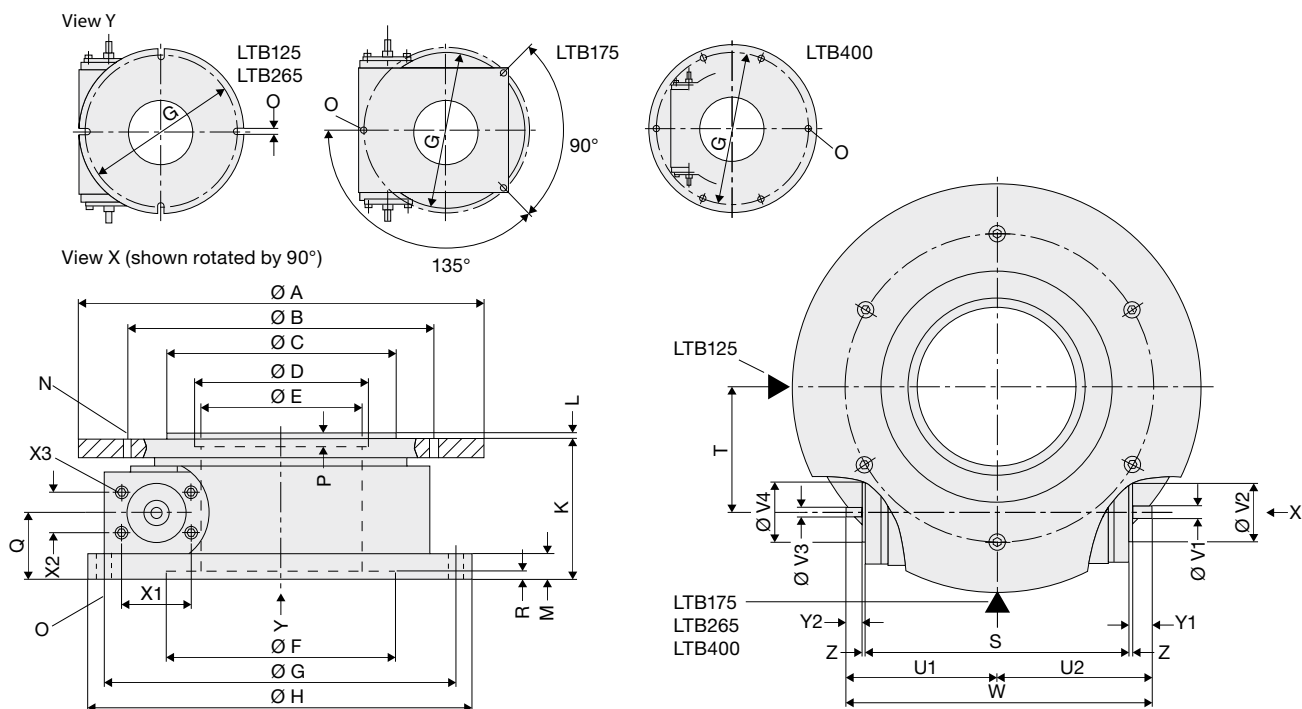

► Grease nipples according to DIN 3405

Rated Ø	Load rating	Overturning moment	Input speed	Reduction ratio	Output speed	Input torque	Output torque	Weight	Order no.
mm	kN	Nm	rpm		rpm	Nm	Nm	kg	
A	C ₀	C _{0m}	N _{1 max}	i	N _{2 max}	M _{1 max}	M _{2 max}		
125	1950	110	2500	360	7	0.7	70	3	91042A
175	2550	140	2500	360	7	0.9	75	6	91043A
265	4200	310	2500	360	7	1.5	160	10	91044A
400	14100	1780	2500	360	7	2.0	290	27	91045A

Rated Ø																								
A	B	C ^{g6}	D ^{H7}	E	F ^{H7}	G	H	K	L	M	N	O	P	Q	R	S	T	U1	U2	V ₁ ^{g6}	V ₂ ^{g6}	V ₃ ^{g6}	V ₄ ^{g6}	W
125	100	-	70	70	100	150	165	75	-	10	4xM5	4x7.0	5	34	5	112	60	67.5	67.5	6	22	6	22	135
175	126	-	102	70	102	178	-	82	-	12	6xM6	3x6.6	4	31	4	152	63	98.0	98.0	6	52	6	52	196
265	200	150	-	105	150	230	250	90	4	16	6xM10	4x10.0	-	43	5	171	81	95.0	98.0	8	38	6	38	193
400	340	300	200	190	270	380	400	100	4	16	6xM10	6x11.0	5	43	5	229	139	124.0	127.0	8	38	6	38	251

Rated Ø	X1	X2	X3	Y1	Y2	Z
125	21.8	26	2xM4/16 low	8	9	2.8
175	50.0	32	4xM4/13 low	18	18	4.0
265	45.0	26	4xM5/24 low	10	7	2.5
400	45.0	26	4xM5/24 low	9	6	2.5



Characteristics

Franke rotary tables of type LTB are open-center, ready-to-use positioning units. They are highly resilient, lightweight (aluminium housing) and deliver outstanding ATR accuracy and discrimination. Franke rotary tables of type LTB are versatile in use and are primarily suited to movement and positioning tasks in the fields of measurement, testing and orientation.

Material

Housing	Aluminium corrugated
Ball race rings	54SiCr6
Rolling element	100Cr6
Worm wheel	Wear-resistant bronze alloy
Worm shaft	CK45N hardened and ground

Accuracies	LTB125	LTB175	LTB265	LTB400
Radial and axial run accuracy	20 µm	20 µm	20 µm	30 µm
Positioning accuracy in arc seconds	80 sec	80 sec	70 sec	50 sec
Repeatability in arc seconds	16 sec	14 sec	10 sec	8 sec

Technical details

Reduction ratio	360:1
Operating temperature	-10 °C to +80 °C
Rotational speed	max. 7 min ⁻¹
Mounting position	any
Lubrication	with bearing grease via grease nipples
Optional	Inductive proximity switch, flange/coupling to mount the motor, motorization



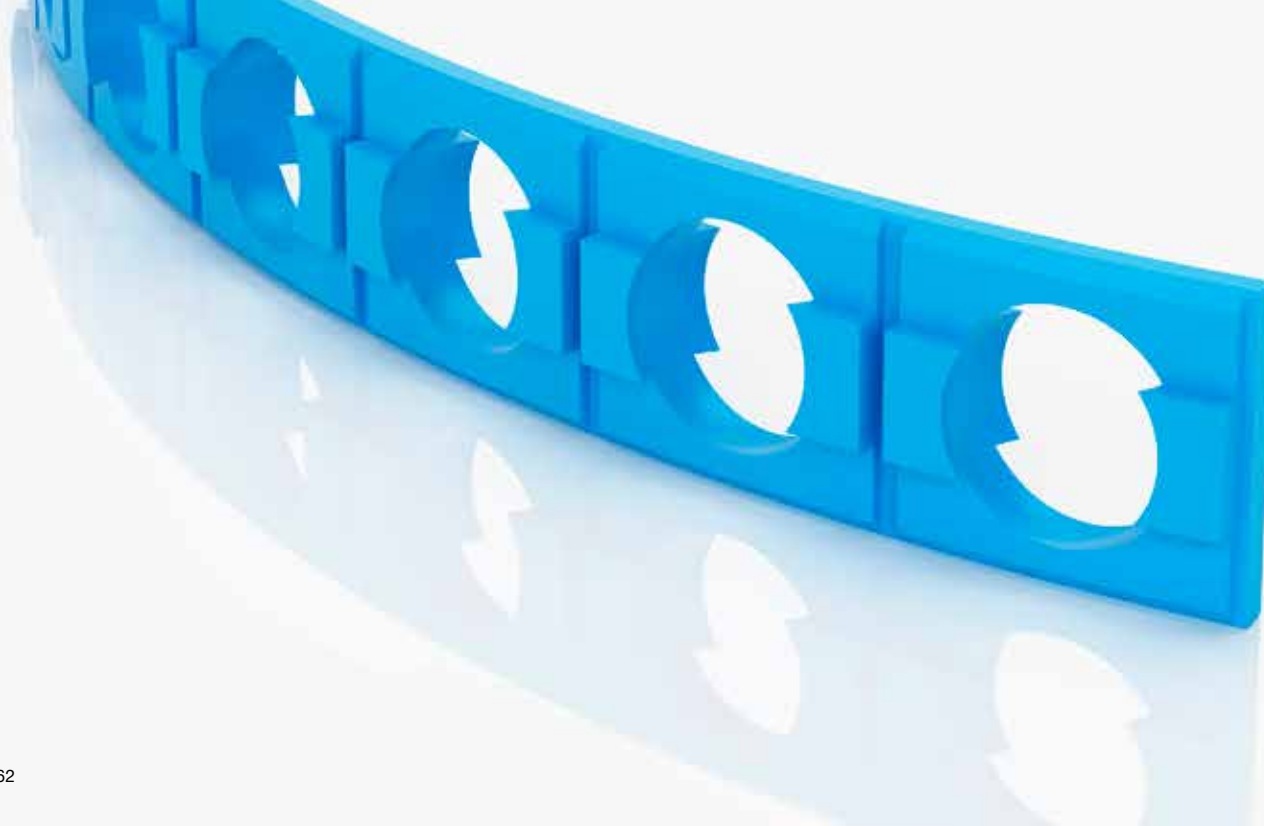
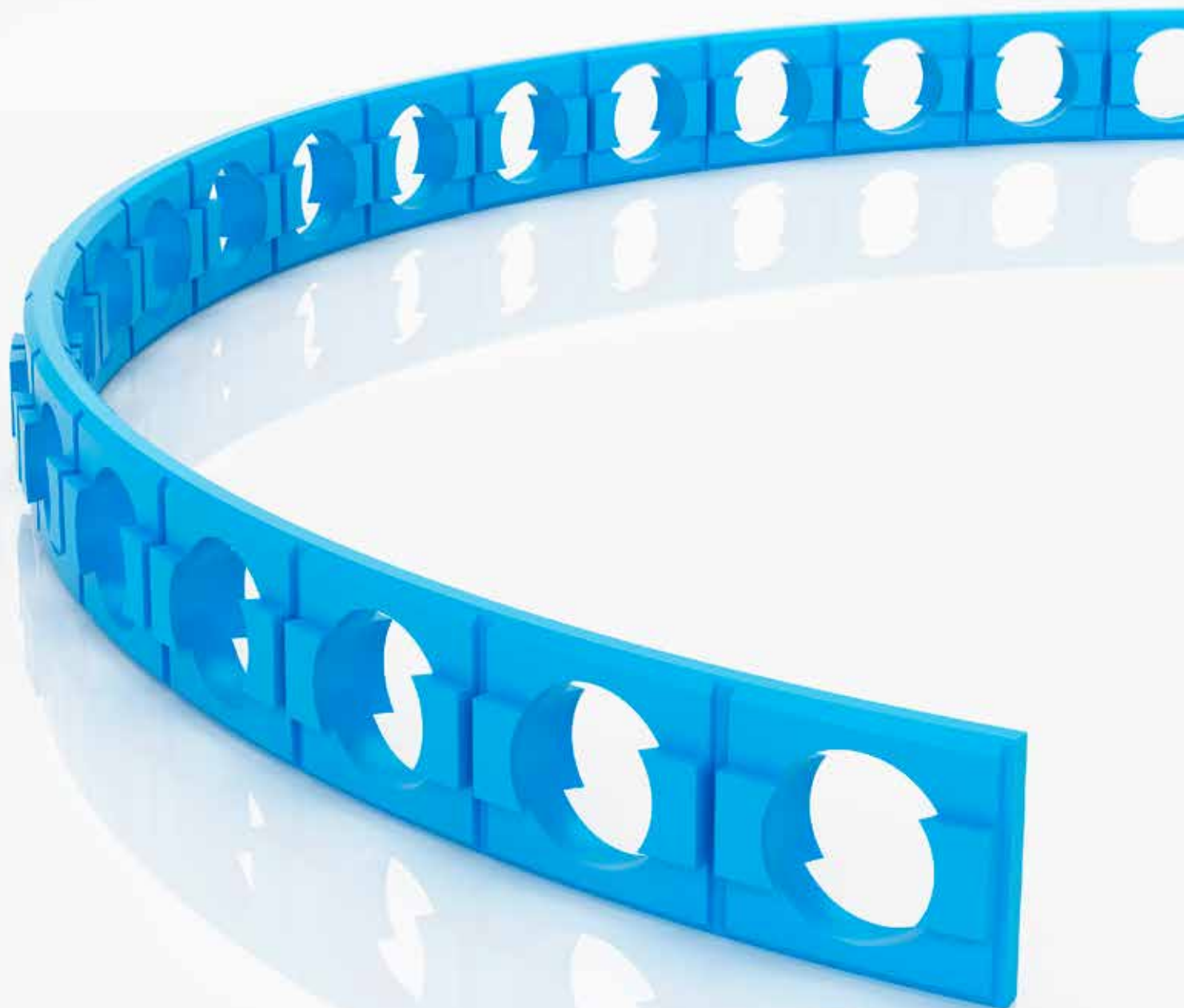

Accessories

Wire Race Bearings

Product	Type/Characteristic	Page
Standard cages	LBK, plastic band cage, incl. balls	64
Special cages	Made of hard fabric, non-corrosive, brass	64
Washers	For Screw sizes M 6 to M 16	65
Seals	Standard sleeve seal	65

Accessories

Wire Race Bearings

Standard cages

Band cages for the LBK series

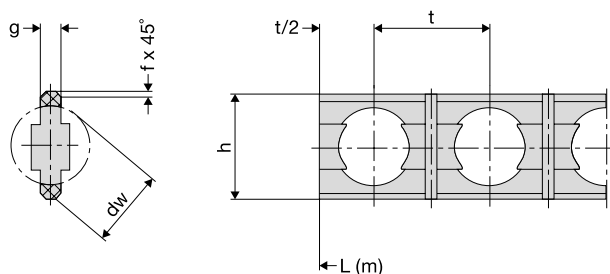

The band cage is segmented in the length required respectively and delivered fitted with balls and ready-to-use. The number of balls required is based on:

$$Z = \left[\frac{KK\varnothing \cdot \pi}{d} \right] = 1$$

Z = number of bearings
 $KK\varnothing$ = raceway diameter
 t = bearing separation (tolerance ± 0.2)

Special cages

Flat cages made of hard fabric, non-corrosive, brass

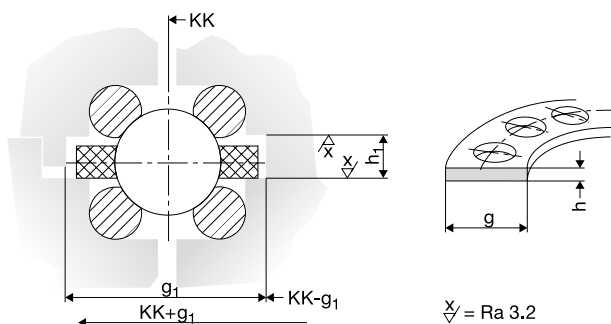

Band cages made of hard fabric, non-corrosive, brass

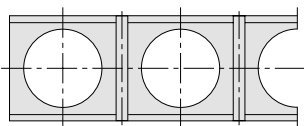

Prong-type cages

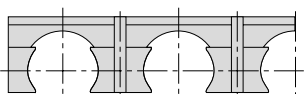

Cage size	dw		Dimensions				Order no. (by the meter)
	mm	inches	h	g	d	f	
LBK5	5.0	3/16	7.6	1.5	7.5	0.4	78916A
LBK6	6.0		8.6	1.6	9.2	0.4	78917A
LBK8	8.0	5/16	10.6	2.0	12.0	0.6	78918A
LBK9.5	9.5	3/8	12.6	2.5	14.0	0.7	78920A
LBK10	10.0		13.2	2.5	14.0	0.7	78921A
LBK11	11.0		13.2	2.5	14.0	0.7	78922A
LBK12V	12.0		17.0	3.5	14.0	0.7	78923B
LBK15	15.0		18.6	3.0	18.6	0.7	78924A
LBK16	16.0		19.6	3.0	20.0	0.7	78925A
LBK20	20.0	25/32	24.2	3.5	26.0	0.7	78926A

Material: PA12

The number of segments is dependent on the bearing diameter and the ball size. Indicative values:

KK \varnothing mm	< 200	200–399	400–799	800–1500
Number of segments	3–4	4–6	6–8	8–12

The band cage can also be created in one part for special applications.

dw mm	h x g mm	h1 x g1 mm	Order no.
5.0	2 x 10	2.7 x 13	on request
6.0	2 x 12	2.7 x 15	
8.0	3 x 15	4.0 x 18	
9.0	3 x 16	4.0 x 18	
9.525	3 x 18	4.0 x 20	
12.0	4 x 20	5.5 x 23	
16.0	5 x 26	6.5 x 30	
20.0	6 x 31	7.5 x 35	
25.0	8 x 38	10.0 x 43	
30.0	8 x 45	10.0 x 50	
40.0	12 x 56	14.0 x 61	
50.0	15 x 80	17.5 x 88	

Material: Hard fabric, brass, non-corrosive

It is mandatory to use a flat cage for temperatures exceeding 100 °C and with bearing diameters larger than 20 mm. Special solutions, including complete non-corrosive properties or radiation resistance, are also possible.

Special cages in the form of band or prong-type cages are available for special requirements in terms of ambient conditions or mounting space.

Franko also delivers materials such as plastic, non-corrosive, brass and Teflon.

Washers

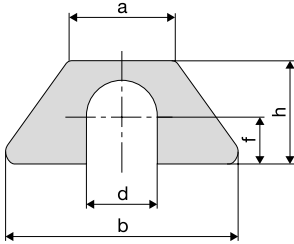

Larger bearings and bearing elements use washers to simplify adjustment between the separate inner and outer rings. The washers are made of non-corrosive sheet steel. It is sensible to include in the design specifications a theoretical initial gap of 0.5 mm for the adjustment.

Size	Dimensions mm					Order no.							
	a	b	d	f	h	Thickness mm							
						0.025	0.1	0.15	0.2	0.25	0.3	0.5	1.0
M 6	11.0	24.4	7	5	11.0	79015A	79034A	79035A	79036A	79037A	79038A	79039A	79040A
M 8	14.7	34.2	9	6	13.5	79041A	79023A	79042A	79000A	79026A	79043A	79044A	79045A
M 10	16.4	42.3	11	7	16.0	79046A	79012A	79010A	79011A	79047A	79048A	79049A	79050A
M 12	20.3	46.0	13	8	18.0	79118A	79051A	79052A	79053A	79054A	79055A	79056A	79065A
M 16	25.4	54.0	17	11	24.0	79119A	79024A	79066A	79057A	79058A	79059A	79060A	79061A

Seals

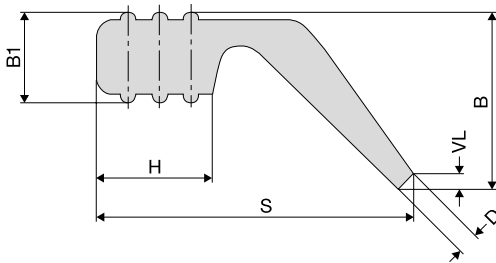

By standard, the bearing assemblies are fitted with sleeve seals S120. Temperature: -30 °C to +80 °C (NBR). Max. circumferential speed: 5 m/s.

The seals can be ordered by the meter in order to seal the construction (e.g. when using a bearing element). The joint is then bonded using adhesive agent Loctite 401®.

Profile	Dimensions mm				Material	Preload mm	Weight kg/m	Order no.
S	H	B _{±0.3}	B1 _{±0.2}	D		VL ¹		
09	3.5	4.8	2.5	0.8	Perbunan 70NBR/221	0.5...1.5	0.016	00928
10	4.2	5.3	3.0	0.8	Perbunan 70NBR/221	0.5...1.5	0.026	09080
10	4.2	5.3	3.0	0.8	Viton	0.5...1.5	0.026	46062
15	5.5	8.5	4.3	1.0	Perbunan 70NBR/221	0.5...2.0	0.051	09190

¹ Depending on bearing assembly (approx. 1 Nm/m seal).

Mounting dimensions

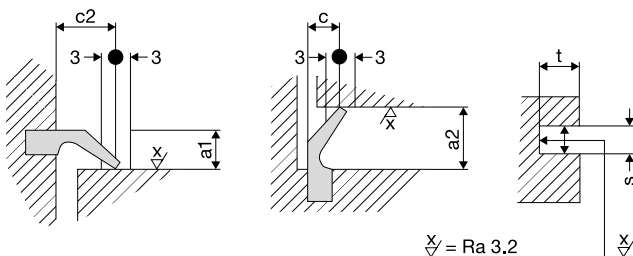

Profile	Mounting dimensions mm				Groove dimension mm	
	c	c2	a1	a2	t ^{+0.2}	s ^{+0.1}
09	4.5+1	5.2+1	3.1...4.1	4.0...5.0	3.5	2.35 ^{+/-0.05}
10	5+1	5.5+1	3.6...4.6	4.3...5.3	4.2	2.8
15	8+1.5	9.0+1.5	6.3...7.7	7.5...9.0	5.5	3.9

Important notice: First measure the seal, then cut the groove.

Special seals are available on request. Franke offers Viton seals for high temperatures or aggressive media.

Technical Information

Wire Race Bearings

Table of contents	Page
1 Wire Race Bearing selection	68
1.1 Parameters to select bearings	
1.2 Static and dynamic load-bearing capacity, calculation	
2 Calculation	68– 69
2.1 Terms, dimensions	
2.2 Static calculation	
2.2.1 Axial and radial factors	
2.2.2 Recommended Static safety S_{st}	
2.3 Dynamic calculation	
2.3.1 Nominal service life	
2.3.2 Axial and radial loads	
2.3.3 Axial and moment stress and axial stress with $F_r = 0$, $M_k = 0$	
2.3.4 Radial and moment stress and radial stress with $F_r = 0$, $M_k = 0$	
3 Calculation example of bearing elements	69– 70
4 Design and production of the bearing bed	70– 72
4.1 Wire bed design for bearing elements type LEL	
4.2 Wire bed design for bearing elements type LER	
4.3 Wire bed design for slim bearings type LSA/LSB	
5 Assembly	72– 75
5.1 Installation and adjustment of bearing elements	
5.1.1 Setting using washers	
5.1.2 Setting using solid adjustment	
5.2 Installation and adjustment of slim bearings	
5.2.1 Setting using washers	
5.2.2 Setting using solid adjustment	
6 Installation and setting of bearing assemblies	75– 77
6.1 Lubrication and maintenance	
6.2 Initial lubrication resp. re-newed lubrication	
6.3 Relubrication and lubrication schedule	
6.4 Lubrication and lubrication schedule for the gear	
6.5 Screw connections	
6.6 Gear	
6.7 Tolerances and accuracy	
7 Rotary tables	77
7.1 Load-bearing capacity	
7.2 Temperature range	
7.3 Lubrication	
7.4 Options	

Technical Information

Wire Race Bearings

1 Wire Race Bearing selection

The ideal selection, i.e. selection of bearings should take place before the start of design. The underlying question is which bearing series will deliver the greatest benefits in the respective application:

- Bearing elements (type LEL, LER):
 - Maximum possible integration capacity
 - Series application to meet cost constraints
 - Greatest possible flexibility based on preload, runnability and diameter ranges
- Slim bearings (type LSA, LSB):
 - Simple, compact integration within your designs
 - Cost-effective alternative to standard slim bearings
 - Not preloaded bearings
- Bearing assemblies (type LVA, LVB, LVD, LVE):
 - Ready-to-use standard bearings with a large selection range
 - Preloaded free from clearance (optimized for rigidity, speed and service life)
 - Available on short notice
- Bearing assemblies (type LVC):
 - Ready-to-use standard bearings for high rotational speeds
- Rotary systems (type LTA):
 - Robust, standard rotary table with worm drive for handling and standard positioning tasks at high speed
- Rotary systems (type LTB):
 - Rotary table with worm gear for highly accurate measurement and positioning tasks

1.1 Parameters to select bearings

- Proper dimensions and material information of bearings
- Loads with load collectives and corresponding time quotients in %
- Rotational speed, i.e. number of swinging movements and swing angles per time unit
- Circumferential forces that the gear transfers
- Other operating conditions such as temperature, vacuum, clean room, moisture, etc.

An approximate bearing selection is possible based on our calculation formulae. The relevant data on this are found on the individual type pages.

1.2 Static and dynamic load-bearing capacity – calculation

The details listed in the catalogue concerning static and dynamic load rating are sufficient for initial design, but not for scaling. The load ratings mentioned are the radial load ratings. The static axial radial moment load ratings, i.e. the dynamic axial and radial load ratings are required to deliver ideal design. The axial values are higher by approx. facto 2.

2 Calculation

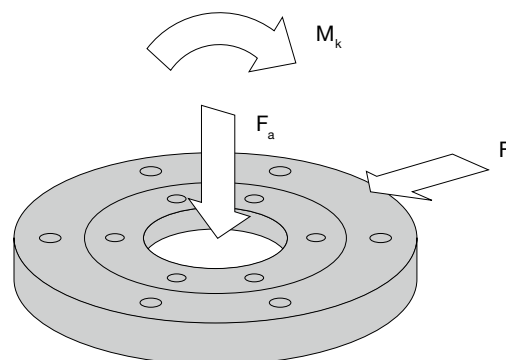

All forces and moments acting on the bearing must be summarised in centrally prevalent forces F_a and F_r , also the consequent moments M_a , by vector addition. We would be pleased to make the calculation on your behalf for complex load incidences and load collectives with changing load and speed.

2.1 Terms, dimensions

C	dynamic rated load	(N)
C_0	static rated load	(N)
F_a	centrally-acting axial force	(N)
F_r	centrally-acting radial force	(N)
$KK\emptyset$	ball pitch diameter = $(D + d)/2$	(M)
L_n	nominal service life	(h)
M_k	tilting moment	(Nm)
P	dynamic equivalent load	(N)
P_0	static equivalent load	(N)
S_{st}	static safety	
X	radial factor	
Y	axial factor	
Z	moment factor	

2.2 Static calculation

A static calculation is sufficient if the bearing is at rest or is subject to load at low rotational and swinging movement with a circumferential speed in the ball pitch of $V \leq 0.1$ m/s. A bearing with sufficient load-bearing capacity would be chosen once the recommended static safety is reached.

$$S_{st} = \frac{C_0}{P_0} \quad (-)$$

$$P_0 = X_0 \cdot F_r + Y_0 \cdot F_a + \frac{2 M_k}{KK\emptyset} \quad (N)$$

2.2.1 Axial and radial factors

	X_0	Y_0
All bearing types	1.0	0.47

2.2.2 Recommended Static safety S_{st}

Ball diameter > 6	S_{st}
During smooth operation without vibration	> 1.8
During normal operation	> 2.5
During pronounced impact loads and high requirements concerning run accuracy	> 8

2.3 Dynamic calculation

A circumferential speed of $v > 0.1$ m/s will require a static and dynamic calculation, in which the static safety S_{st} must at least reach the recommended value for each load.

2.3.1 Nominal service life

$$L_h = \left(\frac{C}{P}\right)^3 \cdot \frac{10^6}{60 \cdot N} \quad (h)$$

2.3.2 Axial and radial loads

$$P = X \cdot F_r + Y \cdot F_a \quad (N)$$

	$\frac{F_a}{F_r} \geq 1$	$\frac{F_a}{F_r} > 1$		
	X	Y	X	Y
All bearing types	1.26	0.45	0.86	0.86

2.3.3 Axial and moment load and axial load with $F_r = 0, M_k = 0$

$$P = Y \cdot F_a + Z \cdot \frac{M_k}{KK\emptyset} \quad (N)$$

	$0 < \frac{M_k}{F_a \cdot KK\emptyset} \leq 0.5$	$\frac{M_k}{F_a \cdot KK\emptyset} > 0.5$		
	Y	Z	X	Z
All bearing types	0.86	1.72	0.45	2.54

2.3.4 Radial and moment load and radial load with $F_r = 0, M_k = 0$

$$P = X \cdot F_r + Z \cdot \frac{M_k}{KK\emptyset} \quad (N)$$

	$0 < \frac{M_k}{F_r \cdot KK\emptyset} \leq 0.5$	$\frac{M_k}{F_r \cdot KK\emptyset} \leq 0.5$		
	X	Z	X	Z
All bearing types	1.0	1.68	0.86	1.96

We are pleased to conduct the calculation on your behalf for the load case radial, axial and moment load.

3 Calculation example of bearing elements

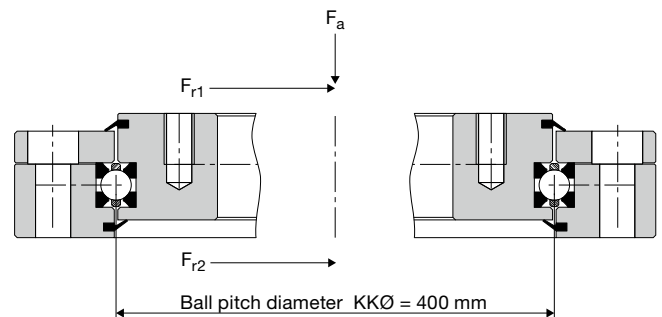

Load data:

Load case A (static load)

Central axial force consisting of net weight + load

$$F_a = 22 \text{ kN}$$

Radial force from working pressure

$$F_{r1} = 4.2 \text{ kN}$$

Technical Information

Wire Race Bearings

Load case B (dynamic load)

Central axial force consisting of net weight + load	$F_a = 22 \text{ kN}$
Radial force from drive	$F_{r2} = 1.5 \text{ kN}$
Average operating speed	$n = 9.5 \text{ 1/min}$

Calculation for bearing element LEL 4 with KKØ 400 mm.

Data: C_{0a}	= 240 kN
C_{0r}	= 113 kN

Calculation:

Load case A (static load)

$$S_{st} = \frac{1}{\frac{22}{240} + \frac{4.2}{113}}$$

Safety $S_{st} = 7.8$ (sufficient for bearing in normal operation)

Load case B (dynamic load)

$$S = \frac{1}{\frac{22}{240} + \frac{1.5}{113}}$$

Safety $S = 9.5$ (hence greater than the required minimum safety under 2.2.2)

$$\text{Service life } L_h = \left(\frac{29}{20.2} \right)^3 \cdot \frac{10^6}{60 \cdot 9.5} = 5200 \text{ h}$$

$$(P = 0.86 \cdot 1.5 \text{ kN} + 0.86 \cdot 22 \text{ kN} = 20.2 \text{ kN})$$

4 Design and production of the bearing bed

Bearing elements consist of two bearing elements and a multi-part, segmented cage with balls. The race rings are open; their diameter can therefore be altered elastically for mounting.

The balls satisfy quality class 3 (DIN 5401). Only use the balls contained in the delivery. If balls are lost, please replace all other balls also to avoid impeding the runnability of the bearing.

Design and ideal technical production, also the correct setting of preload, are important conditions in ensuring long service life. This guarantees that all raceways are involved in accommodating the load and that the balls run ideally on their predefined positions.

The design and production of the wire bed differs for the individual bearing elements and slim bearings; the following contains corresponding descriptions.

4.1 Wire bed design for bearing elements type LEL

The bearing elements LEL offer the best runnability and running accuracy, but also place the highest demands in design of the wire bed. Here are two scaled diagrams for the most important parameters:

1. Adjustment through grinding (sold adjustment)

It is important to take care in the design of the mating components that the housing parts to be joined together are manufactured with oversize to achieve the desired preload in the bearing by grinding the lid.

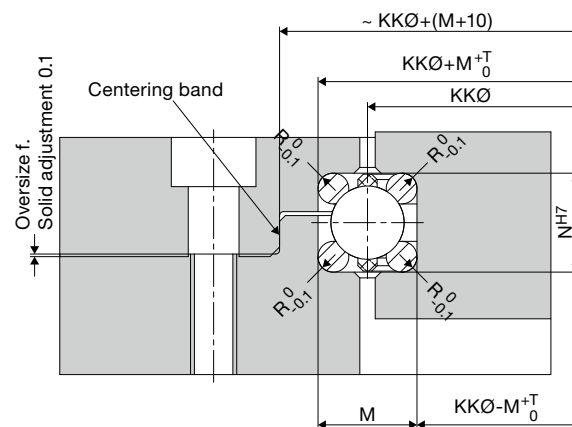

2. Adjustment using washers

It is important to take care in the design of the mating components that the housing parts to be joined together are manufactured with undersize to achieve the desired preload in the bearing by adding washers.

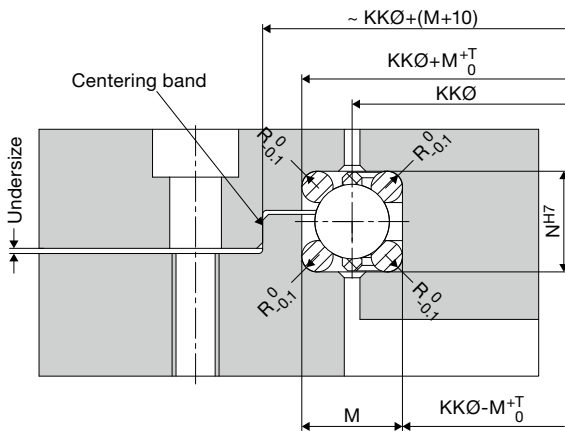

The dimensions and tolerances are calculated as follows:

$$R = \lambda - 0.1$$

$$T = KK\varnothing / 10,000 \text{ (dimensions in mm)}$$

Oversize for grinding, i.e. undersize for additional washers: 0.1 mm

Fit tolerance for central fit

Bore: lower tolerance: +0.01;
upper tolerance: +0.01 +IT6

Shaft: upper tolerance: -0.01;
lower tolerance: -0.01 -IT6

In a design sense it is worthwhile to create a separated bearing stator, but the rotor should generally comprise one part only. The individual accuracies influence the required accuracy; accordingly, separated rings should be apportioned $\frac{2}{3}$ of the radial/axial tolerances, while single-part rings are apportioned half of the radial/axial tolerances.

Half of the diameter tolerance principally applies to the roundness of the wire bed; the screw-on surface of the connecting construction applies to the axial runout. The center of the wire bed is always the basis for the radial runout. Evenness and parallel quality of the individual components are designed with one half of the overall tolerance.

Take care when designing the mating components that the parallel surfaces that are not joined (e.g. surface above the centering band) is designed with a sufficient interval to ensure they have sufficient space once the bearings have been adjusted. Design the chamfers and radii on the fit in such a

way that the joint surfaces can be screwed together without collisions occurring in the area of the cylinder edges.

In general it is true that the accuracy of the bearing assembly is improved if the wire bed of the separated ring is manufactured once the two rings have been screwed together and dowelled using pins. Further, the mounting fit of the bearing must be processed together with the wire bed in one setting. It is sufficient to manufacture the wire bed by means of machining or milling; the recommended surface qualities are $< Ra 3.2$, as high surface quality has a positive influence on the settling behavior of the bearings.

The wire bed should always be processed in one setting with contours correlated with the centering or runnability; this helps achieve ideal accuracy and service life of the bearing. We recommend protecting the wire bed against wear if soft materials are used (e.g. by anodizing or chemical nickel-plating, etc.).

4.2 Wire bed design for bearing elements type LER

The bearing elements LER offer significantly greater simplicity compared with the LEL series in terms of the mating rotary components. Here it is possible to adjust the bearing using a simple lid plate and washers. Like with the LEL, the wire bed must be separated, and centering of the separated ring is not necessary.

It is important to take care in the design of the mating components for systems with lid that the wire bed fitted with lid is manufactured undersized; this ensures that through addition of washers, the desired preload in the bearing can be reached.

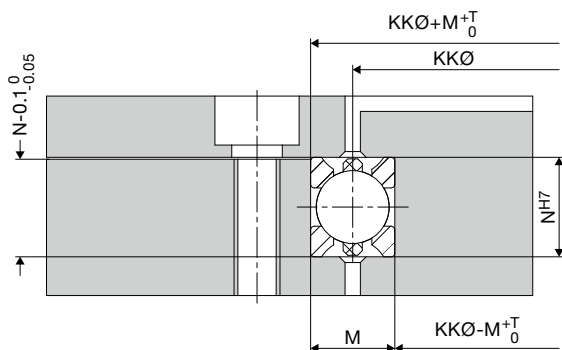

Technical Information

Wire Race Bearings

The information provided in the LEL section applies to the constructive design. The wire bed does not possess any radii that accommodate the race ring, but the tool radii must not be greater than 0.2 mm.

$T = KK\varnothing/10.000$ (dimensions in mm)
Undersize for washers: 0.1 mm

In a design sense it is worthwhile to create a separated bearing stator, but the rotor should generally comprise one part only. The individual accuracies influence the required accuracy; but seeing as the wire bed of the separated ring is also not offset radially, the radial and axial tolerances are divided evenly between the two rings.

Half of the diameter tolerance principally applies to the roundness of the wire bed; the screw-on surface of the connecting construction applies to the axial runout. The center of the wire bed is always the basis for the radial runout.

Evenness and parallel quality of the individual components are designed with one half of the overall tolerance.

The mounting fit of the bearing must be processed together with the wire bed in one setting. It is sufficient to manufacture the wire bed by means of machining or milling; the recommended surface qualities are $< Ra\ 3.2$, as high surface quality has a positive influence on the settling behavior of the bearings.

4.3 Wire bed design for slim bearings type LSA

Unlike the bearing elements LEL and LER described above, the LSA bearing elements cannot be adjusted and always come with clearance. According to the specifications listed below, the bearings have a clearance of between 0.02 and 0.08 mm. The wire bed is separated like with the LER; it is not possible to set the clearance.

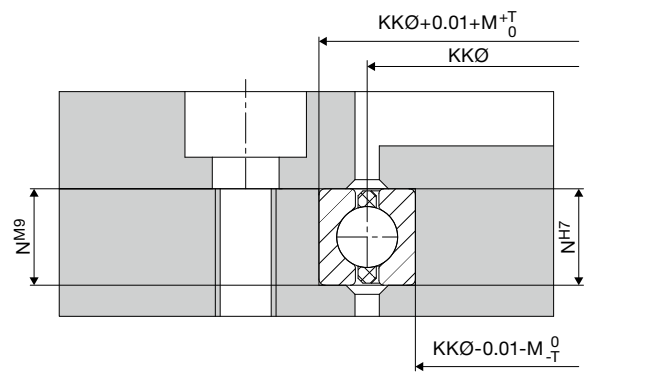

It is sensible in the constructive design to integrate the outer ring in the separated element of the mating structure, given that assembly, and specifically insertion of the ring in the mating structure, is easier to manage in this way.

The wire bed does not possess any radii that accommodate the race ring, but the tool radii must not be greater than 0.2 mm.

$T = 0.03$ mm for KK bis 300 | 0.04 mm for KK larger than 300 (dimensions in mm)

Half of the diameter tolerance principally applies to the roundness of the wire bed; the screw-on surface of the connecting construction applies to the axial runout. The center of the wire bed is always the basis for the radial runout.

The mounting fit of the bearing must be processed together with the wire bed in one setting. It is sufficient to manufacture the wire bed by means of machining or milling; the recommended surface qualities are $< Ra\ 3.2$, as high surface quality has a positive influence on the settling behavior of the bearings.

5 Assembly

5.1 Installation and adjustment of bearing elements

5.1.1 Setting using washers

Setting the washers is the most economical and flexible procedure, as it also permits downstream alteration of the rotational resistance. Washers in a variety of thickness can be ordered, dependent on the diameter of the screws (see Accessories p. 65).

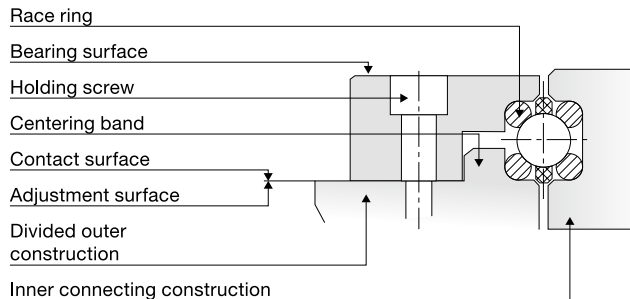

Requirements:

- Separation of the inner or the outer ring construction.
- The height of the race ring bed is smaller on one side of the separated connecting construction: 0.3 to 0.5 mm. This gap is needed to accommodate the washers.
- The separated side of the connecting construction should be fixed in place using a centering band. This is the only means of ensuring that the raceways run parallel.

Installation and setting:

The race rings are inserted in the mating structure. Coat the race ring beds with grease to keep the race rings in position during installation. The joints on the opposing race rings in the same component are installed, each offset by approx. 180°. The separated part of the connecting construction is then installed in its intended position.*

The cage elements with the balls are then inserted, and the bearing element is greased (see 6.1 Lubrication and maintenance). Before closing the mating structure in the separated side it is important to place the washers on the drill holes of the retaining screws. The thickness is dependent on the constructed gap (see above).

Check the rotational resistance once the screws have been tightened (see 6.5 Screw connections) and the bearing assembly has been rotated approx. 2 to 3 times by 360°. Change the thickness of all washers and repeat the process if the measurement value deviates by more than 5 to 10 %.

*Applies to both setting methods: 2.1 and 2.2.

5.1.2 Setting using solid adjustment

When making the setting by means of solid adjustment, the correct dimensions of the adjustment surface are produced by grinding. This method delivers the best accuracies as the separating surface between the separated side of the connecting construction is flush and stress transmission cannot emerge.

Prerequisite:

- Separation of the inner or the outer ring construction.
- Flange grinding machine in a suitable size.
- The height of the race ring bed on the side of the separated connecting construction is 0.1 mm larger. This oversize is needed for adjustment.
- The separated side of the connecting construction should be fixed in place using a centering band. This determines the parallel nature of the two raceways

Installation and setting:

Then the cage segments with the balls are inserted and the bearing assembly is closed with the second separated part of the mating structure (adjustment ring). Use a dial gage to measure the clearance between the inner and outer ring once the screws have been tightened as specified (see 6.5 Screw connections) and the bearing assembly has been rotated approx. 2 to 3 times by 360°. The adjustment ring is then dismantled again and the measurement value registered plus 0.02 to 0.03 mm is ground down using the flat grinder.

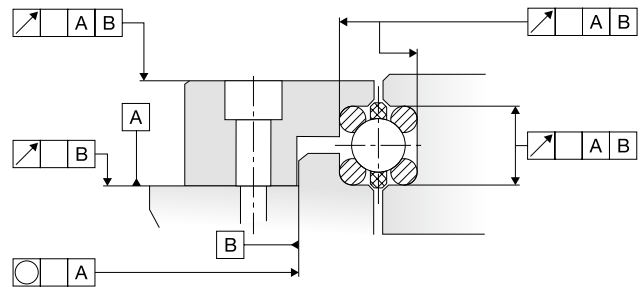

A suitable support surface should be selected as early as the design phase to ensure parallel adjustment between this surface and the raceway support. The ring is fitted and the bearing moved as described above once the grinding dust has been thoroughly removed. Then check the rotational resistance. The process must be repeated if this measurement value deviates by more than 5 to 10 %. Finally the bearing assembly is lubricated using the fitted lubricant bores (see 6.1 Lubrication and maintenance).

The bearings are designed for continuous operation at temperatures between -10 °C and +70 °C – briefly also for use at up to +120 °C. Circumferential speeds of 10 m/s with grease lubrication and 12 m/s with oil lubrication can be achieved. Setting the preload is an important condition for a long service life of the bearing element. The preload guarantees that all raceways are involved in accommodating the load and that the balls run ideally on their predefined positions. Preload is set correctly if the rotational resistance without seals matches the values in the diagram under item 6.

Note: Setting the preload is advisable as tolerances will exist and require compensation even in the event of ideal production.

Technical Information

Wire Race Bearings

5.2 Installation and adjustment of slim bearings

Slim bearings type LSA

The LSA is a consistent redevelopment of the Wire Race Bearing technology. In LSA two race wires are combined into one. Instead of the four race rings you find in conventional Wire Race Bearings, the LSA has just two. The 4-point principle is maintained by the special profile of the raceways. This makes mounting and adjustment just as simple as for conventional slim bearings with gains in load bearing capacity and rating. Assembly takes place according to the following stages:

1. Clean the components with a clean cloth that does not lint.
2. Grease the race rings (rear side).
3. Insert the inner ring of the LSA into the inner ring of the mating structure. Take care that a gap separates the ends of the race ring ends.
4. Place the cage and the outer race ring on the inner race ring. Hold together the ends of the outer race ring in such a way that the ball cage cannot slip out.
5. Position and axially insert the outer ring.
6. Position and screw on the lid.

Installation proposal:

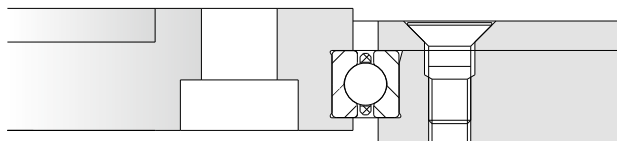

Slim bearings type LSB

Slim bearings of the type LSB are highly resilient, ready-to-use Wire Race Bearings that can be fitted very easily and in a compact mounting space. In slim bearings LSB the bearing element (four ball race rings with ground raceway and with retained balls) is embedded in an inner and outer sleeve made of steel. The sleeves are separated circumferentially and form a ready-to-fit bearing that is directly integrated in the respective design. Unlike standard closed and ground slim bearings, the clearance in Franke slim bearings is not dependent on adjusting the seat of the outer and inner ring. Therefore the installation and dismantling are easier and do not require special tools or thermal treatment.

The bearings are designed for continuous operation at temperatures between $-10\text{ }^{\circ}\text{C}$ and $+70\text{ }^{\circ}\text{C}$ – briefly also for use at up to $+100\text{ }^{\circ}\text{C}$. Circumferential speeds of 10 m/s with grease lubrication and 12 m/s with oil lubrication can be achieved. Setting the preload is an important condition for a long service life of the slim bearing. The preload guarantees that all raceways are involved in accommodating the load and that the balls run ideally on their predefined positions.

Preload is set correctly if the rotational resistance without seals matches the values in the diagram under item 6.

Note: Setting the preload is advisable as tolerances will exist and require compensation even in the event of ideal production.

5.2.1 Setting using washers

Setting the washers is the most economical and flexible procedure, as it also permits downstream alteration of the rotational resistance. Washers in a variety of thickness can be ordered, dependent on the diameter of the screws (see Accessories p. 65).

Requirements:

- Separation of the inner or the outer ring construction.
- The height of the race ring bed is smaller on one side of the separated connecting construction: 0.3 to 0.5 mm. This gap is needed to accommodate the washers.
- The separated side of the connecting construction can be fixed in place using a centering band to improve parallel adjustment of the raceways.

Installation proposal A:

The slim bearing is inserted in the connecting construction. Before closing the connecting construction in the separated side, the washers are fitted on the drill holes of the retaining screws. The thickness is dependent on the constructed gap (see above). Check the rotational resistance once the screws have been tightened (see 6.5 Screw connections) and the bearing assembly has been rotated approx. 2 to 3 times by 360° . Change the thickness of all washers and repeat the process if the measurement value deviates by more than 5 to 10 %.

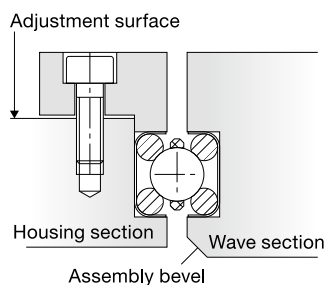

5.2.2 Setting using solid adjustment

When making the setting by solid adjustment, the correct dimensions of the adjustment surface are produced by grinding. This method delivers the best accuracies as the separating surface between the separated side of the connecting construction is flush and stress transmission cannot emerge.

Prerequisite:

- Separation of the inner or the outer ring construction.
- Flange grinding machine in a suitable size.
- The height of the wire bed on the side of the separated connecting construction is 0.1 mm larger. This oversize is needed for adjustment.
- The separated side of the connecting construction can be fixed in place using a centering band. This improves the parallel adjustment between the two raceways.

Installation and setting:

The slim bearing is inserted in the connecting construction and the bearing is closed with the second separated part of the mating structure (adjustment ring). Use a dial gage to measure the clearance between the inner and outer ring once the screws have been tightened as specified (see 6.5 Screw connections) and the bearing has been rotated approx. 2 to 3 times by 360°. The adjustment ring is then dismantled again and the measurement value registered plus 0.02 to 0.03 mm is ground down using the flat grinder. A suitable support surface should be selected as early as the design phase to ensure parallel adjustment between this surface and the raceway support. The ring is fitted and the bearing moved as described above once the grinding dust has been thoroughly removed. Then check the rotational resistance. The process must be repeated if this measurement value deviates by more than 5 to 10%.

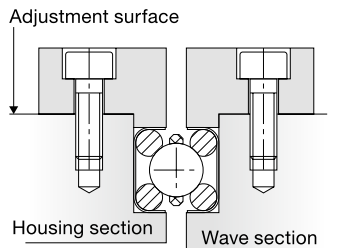

6 Installation and setting of bearing assemblies

Franke bearing assemblies are ready-to-use complete bearings – no matter whether they are standard bearings from the catalogue or customer-specific versions. The specified or defined run accuracy, rotational resistance, rigidity and general properties are dependent on both the connecting construction and on the accuracy and completeness of the data provided. For this reason these are particularly important factors.

6.1 Lubrication and maintenance

Sufficient lubrication is necessary in order to keep friction low and to permanently protect the bearing against corrosion. All lubricants age in a manner that limits their suitability for use. Fully synthetic lubricants deliver the best age-resilience. Use ISOFLEX TOPAS NCA52 (special grease by the firm Klüber, designation according to DIN 51502 is: KHC2 N-50) to lubricate Franke bearings for the first time. The age-resilience of this lubricant is approximately three years. This lubricant is also recommended for use in the bearing elements.

High-quality lithium soap greases on a polyalphaolefine basis or mineral oil basis, i.e. according to DIN 51825-K2 K-40, are suitable as alternatives. Please clarify any questions concerning lubricants, e.g. mixability, aggressiveness, extreme temperatures, disposal, areas of use and such like, with the respective manufacturer.

6.2 Initial lubrication resp. re-newed lubrication

The lubricant quantity that a Wire Race Bearing requires for lubrication is relatively low and adjusts automatically depending on the speed. If the lubricant quantity is too high, the creep may produce elevated temperatures that restrict or eliminate the lubricating properties. The service life of the bearing is reduced substantially by greater wear. The lubricant quantity is dependent on the calculated empty space inside the bearing assembly. The calculated volume must be filled with lubricant to 20 to 30%. 30 to 40% is recommended for swivel bearings.

Franke bearing assemblies are factory lubricated. Bearing elements and slim bearings are treated with anti-corrosive oil for transport and must be lubricated during assembly.

Technical Information

Wire Race Bearings

6.3 Relubrication and lubrication schedule

The lubricating capacity drops due to mechanical load and ageing. It is therefore necessary to replenish or entirely replace the existing lubricant volume (e.g. when severely contaminated). Turn the bearing during relubrication. When possible relubricate at operating temperature.

The relubrication volume is calculated as follows:

$$m = KK\emptyset \times H1/3 \times X$$

H1 = bearing ring height in mm

KK \emptyset = ball pitch diameter in mm

m = relubricant volume in g

X = factor according to Table 1 in mm⁻¹

Relubrication schedule: A precise definition of the schedule is dependent on the specific use and can therefore only be determined accurately by experiment (for approximate values see Table 1). Correlate the metered time with the activated application time to determine factor X (Table 2).

Note: Standard bearings only need one fitted relubrication facility, as the bearing movement itself evenly distributes the lubricant. At least three relubrication facilities are needed for swivel bearings (3 x 120°).

Vu m/s	Interval h
0 bis < 3	5000
3 bis < 5	1000
5 bis < 8	600
3 bis < 10	200

Table 1: Relubrication schedule

Interval	Weekly	Monthly	Yearly	2–3 years
X	0.002	0.003	0.004	0.005

Table 2: Relubrication intervals

Circulation lubrication with oil is essentially possible and should be coordinated with the respective lubricant manufacturer. Lubricant-free bearings are available for special applications (e.g. clean room or ultra-high vacuum).

Calculation example:

Bearing assembly type LVA, KK \emptyset 500 mm,

Circumferential speed 3 m/s

Activation time approx. 16 h/day

The relubrication schedule for 3 m/s is 1000 h (see Table 1) = 1000 (h)/16 (h/day) = 63 days ~ 3 months for 16 h/day activation time

Relubrication should take place quarterly. Consequently, factor X (Table 2) is rounded off and amounts to 0.003. The dimensions H1 is 42 mm (see catalogue page 46).

$$m = 500 \text{ mm} \times 42/3 \text{ mm}^{-1} \times 0.003 \text{ g} = 21 \text{ g}$$

The relubrication quantity is therefore 21 g ISOFLEX TOPAS NCA52 after every three months. The lubricant has a service life of three years.

6.4 Lubrication and lubrication schedule for the gear

Automatic gear lubrication is recommended. Sufficiently lubricate the gear and sprocket by hand before commissioning. The lubrication schedule is dependent on the design and the circumferential speed and must therefore be considered individually.

6.5 Screw connections

Always check the number of screws and their diameter for attachment to the connecting construction. Interval X from retaining screw to retaining screw should not exceed 125 mm to prevent bridges developing. Tighten the fixing screws crosswise in relation to the screw quality using a torque spanner – as defined in the data contained in Table 3.

	Quality Nm	
	8.8	12.9
M 6	10	17
M 8	25	41
M 10	49	83
M 12	86	145
M 16	210	355

Table 3: Tightening torque

Apply the specified tightening torque to tighten the screws in order to prevent any subsidence. When possible complete this when the screws are not exposed to any tensile forces. Inspect the screws after approximately 100 operating hours and then every 1000 operating hours thereafter. This period may also be substantially shorter for special operating conditions (e.g. exposed to severe vibration).

6.6 Gear

By standard Franke provides a straight gear without hardening (material 42CrMo4V); special gears on request. The material, design and quality can be modified at any time to suit individual wishes.

The catalogue data concerning permissible circumferential forces were determined using the permissible bending force in the tooth root. The maximum forces refer to extreme load, e.g. caused by short-term impact due to start-up or braking. These values are approximate values and can only be determined precisely by means of gear calculations accounting for both components (sprocket and bearing assembly).

6.7 Tolerances and accuracy

All tolerances and accuracies are listed on the respective catalogue pages. The greatest levels of accuracy are achieved if the constructive design of the mating parts takes place in such a way that the handling of all diameters and surfaces relating to each other can take place in one setting. The running accuracies indicated in the catalogue are average values and may be improved by restricting the tolerances. The tolerance data T = IT6 or T = IT7 refer to the diameter-dependent basic tolerances according to DIN ISO 286 (see Table 4).

Rated dimension range mm		Basic tolerances µm	
above ...	to	IT6	IT7
80...	120	22	35
120...	180	25	40
180...	250	29	46
250...	315	32	52
315...	400	36	57
400...	500	40	63
500...	630	44	70
630...	800	50	80
800...	1000	56	90
1000...	1250	66	105
1250...	1600	78	125

Table 4: Tolerance data

DIN ISO 286 T1 (11.90)

7 Rotary tables

Franke rotary tables are highly resilient and particularly suited to assembly, measurement and testing tasks. All rotary tables have a compactly structured aluminium housing with integrated Franke components. A worm gear guarantees high accuracy, even under continuous load. The rotary tables have low net weight, yet remain extremely rigid to tilting. Please find precise technical data on this in the catalogue pages.

7.1 Load-bearing capacity

The recommended safety for Franke rotary tables is $S_{st} \geq 3$ for simple load conditions and $S_{st} \geq 6$ for dynamic, alternating load and lifting conditions. Franke is pleased to calculate load and service life as required.

7.2 Temperature range

The rotary tables can be used in operating temperatures from -10 °C to $+80\text{ °C}$. Extended temperature ranges are available on request.

7.3 Lubrication

In general, all standard rotary tables are factory fitted with long-term lubrication using the Wire Race Bearing grease ISOFLEX TOPAS NCA52. Depending on their use, it is recommended to relubricate Franke rotary tables half yearly or yearly.

Lubrication point	Relubrication quantity per lubrication point g		
	left	front	right
LTA100		1	1
LTA200		1	1
LTB125	2		
LTB175		3	
LTB265		3	
LTB400		4	

7.4 Options

- One or two integrated inductive proximity switch(es).
- Free selection of trip cam position
- Fixtures for motors as required by customer
- Motorization with stepper or servo motor, depending on the application
- Rotary encoder fitted at the second shaft end of the worm shaft
- Complete automation solution

Please observe our assembly and maintenance instructions for each item.



The video
Function principle of
Linear Systems
at YouTube
Search term "Franke
Linear Systems"

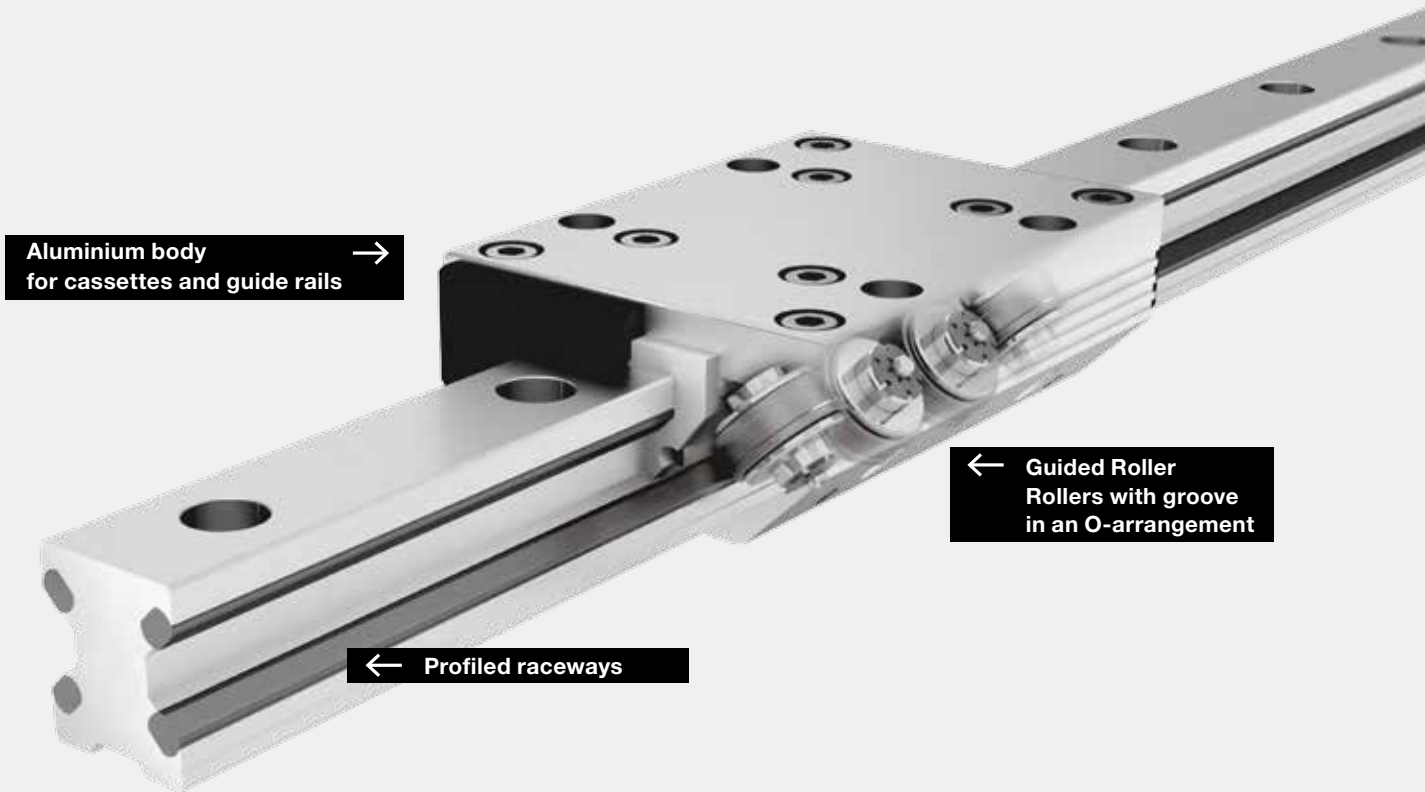

Linear guide
Franke Dynamic

Linear Systems

Aluminium Linear Systems by Franke are the best solution when it comes to speed and lightweight construction. They are highly dynamic, fast, quiet and maintenance-free. Franke offers individual profiles and cassettes, motorized units with measurement systems and controls, also linear modules with direct drive, customized to your requirements. The patented system of Guided Rollers® moves the rollers and raceways ideally.

The modular structure of our Linear Systems allows us to satisfy individual customer wishes. Different rail profiles and roller shoes, special cassettes and variable track widths are among the examples.

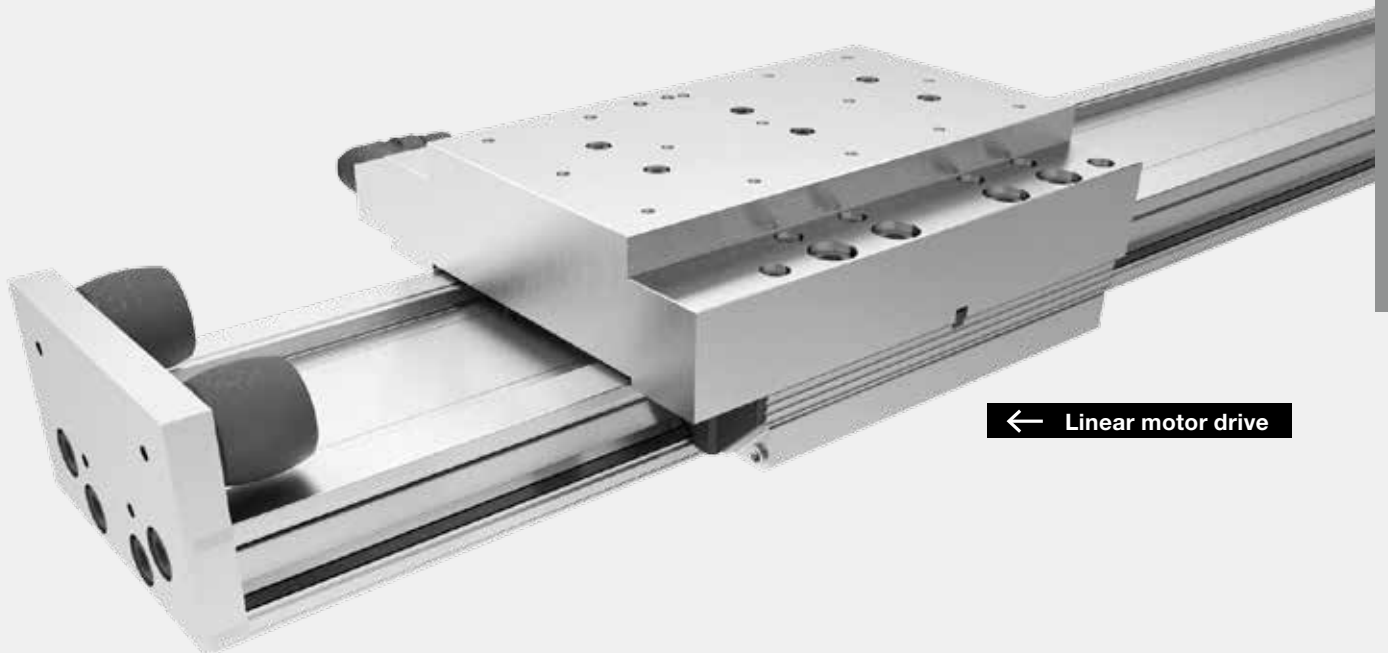

Linear module



Why Franke Linear Systems?

Convincing features of Franke aluminium Linear Systems include their lightweight structure and quiet and easy run. They can be customized to your application in a variety of different ways.

Aluminium – lightweight

The guide rails and cassette bodies are made of aluminium. As a user, this will provide you with several advantages:

- Lightweight designs
- Homogeneous material properties in assemblies with aluminium profiles
- Low moved masses
- Low drive energy required
- High dynamism and speed



The Franke principle – inserted steel wires as raceways

Wire raceways made of steel or non-corrosive inserted in the aluminium body ensure high resilience and load capacity. The wire raceway is aligned with the width of the rollers and keeps them precisely on track.



4-point system to accommodate forces from all directions

The large-scale rollers rotate in needle or ball bearings and are arranged crosswise. They accommodate load from all directions and are convincing in their rapid response behavior.



Maintenance-free over the entire service life

The rollers are lifetime lubricated. The bearings used are sealed to prevent lubricant grease from escaping. The guide system operates cleanly and maintenance-free over the entire service life.



Variable guide widths

The cassette plate is not needed in the version with pair of single rails and roller shoes. This means that the guide width is infinitely variable; the roller shoes are screwed directly to the connecting design.

Advantages:

- Variable guide width
- Extremely low height
- Direct integration in your design

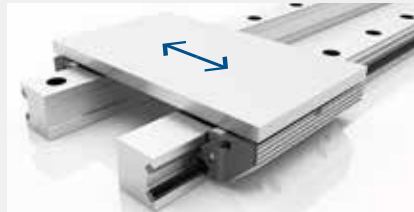

Customer-specific rail profile

The Franke principle of inserted raceways can be transferred to almost any aluminium profile. This enables you to structure your design individually.

Options:

- Variable guide width
- Variable height
- Integration of other components such as drives or measurement systems

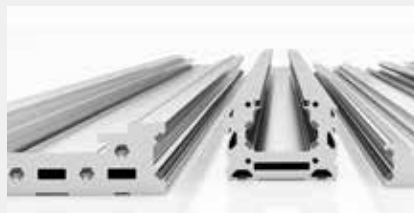

Customer-specific materials and surfaces

We offer linear guides with non-corrosive or non-magnetic race rods and individually refined surfaces for special requirements.

Examples:

- Non-corrosive raceways (corrosion protection)
- Non-magnetic raceways
- Clean room-compatible guides
- Anodized in different colors



Customer-specific cassettes and roller shoes

The form of cassettes and roller shoes can be integrated in your application. For instance, mounts for drive spindles can be integrated.

Customer specifications:

- Special dimensions
- Variable number of rollers
- Variable adjustment of the rollers



Motorized modules: Type FTI with toothed belt drive

Modules in type FTI have raceways and toothed belt drive protection through integration on the inside of the aluminium profile.

Characteristics:

- Protected raceways
- Lightweight construction (aluminium body)
- Attractive price

Please find additional information on the linear module type FTI on pages 110–111.



Motorized modules: Type FTH with integrated linear motor

Franke Linear Systems are available fitted with drive and control. Modules in type FTH have an integrated linear motor and are convincing in their:

- High dynamism
- High travel speed
- Low height
- Lightweight construction (aluminium body)

Please find additional information on the linear module type FTH on pages 112–115.

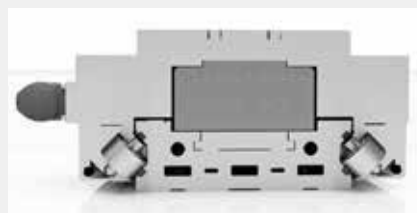

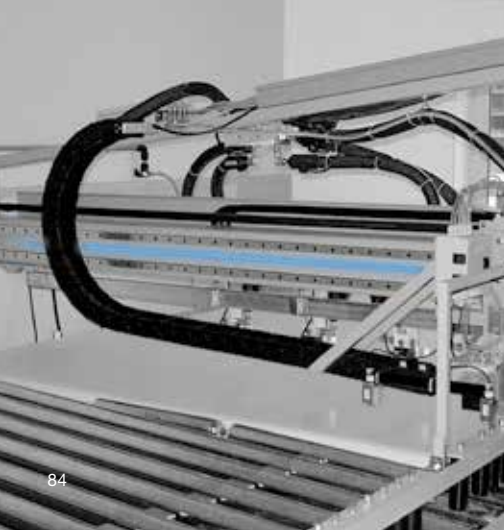
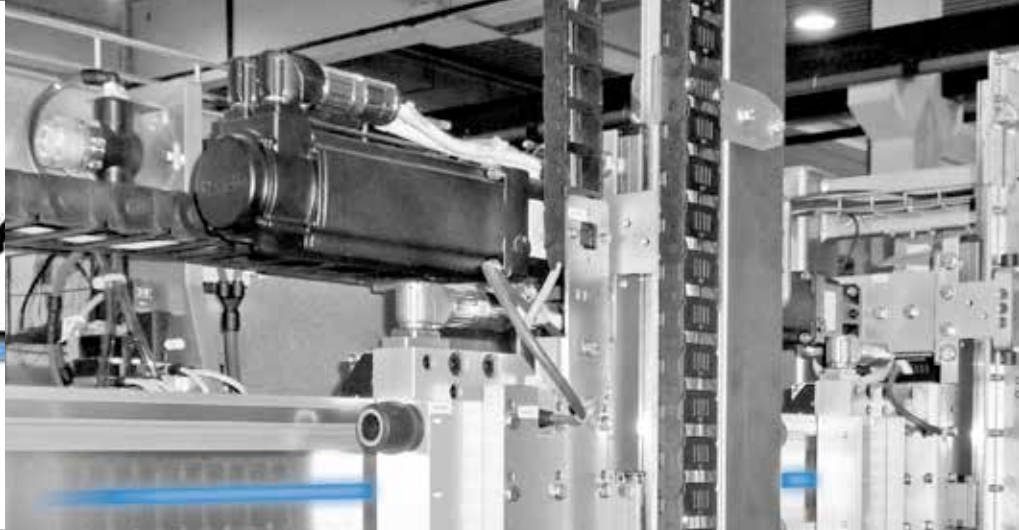
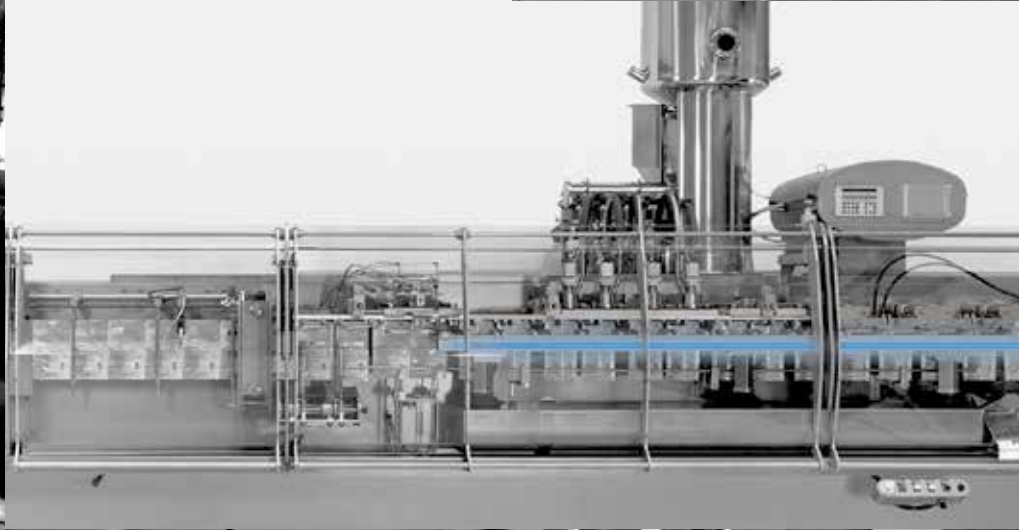
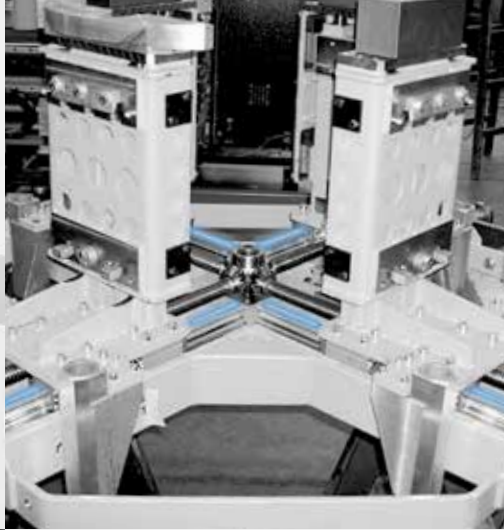



Accuracy along the entire line

Franke Linear Systems. For individual customer requirements. Highly dynamic. Maintenance-free. Ideal movement. Quiet. Aluminium for lightness. For speed and lightweight design.



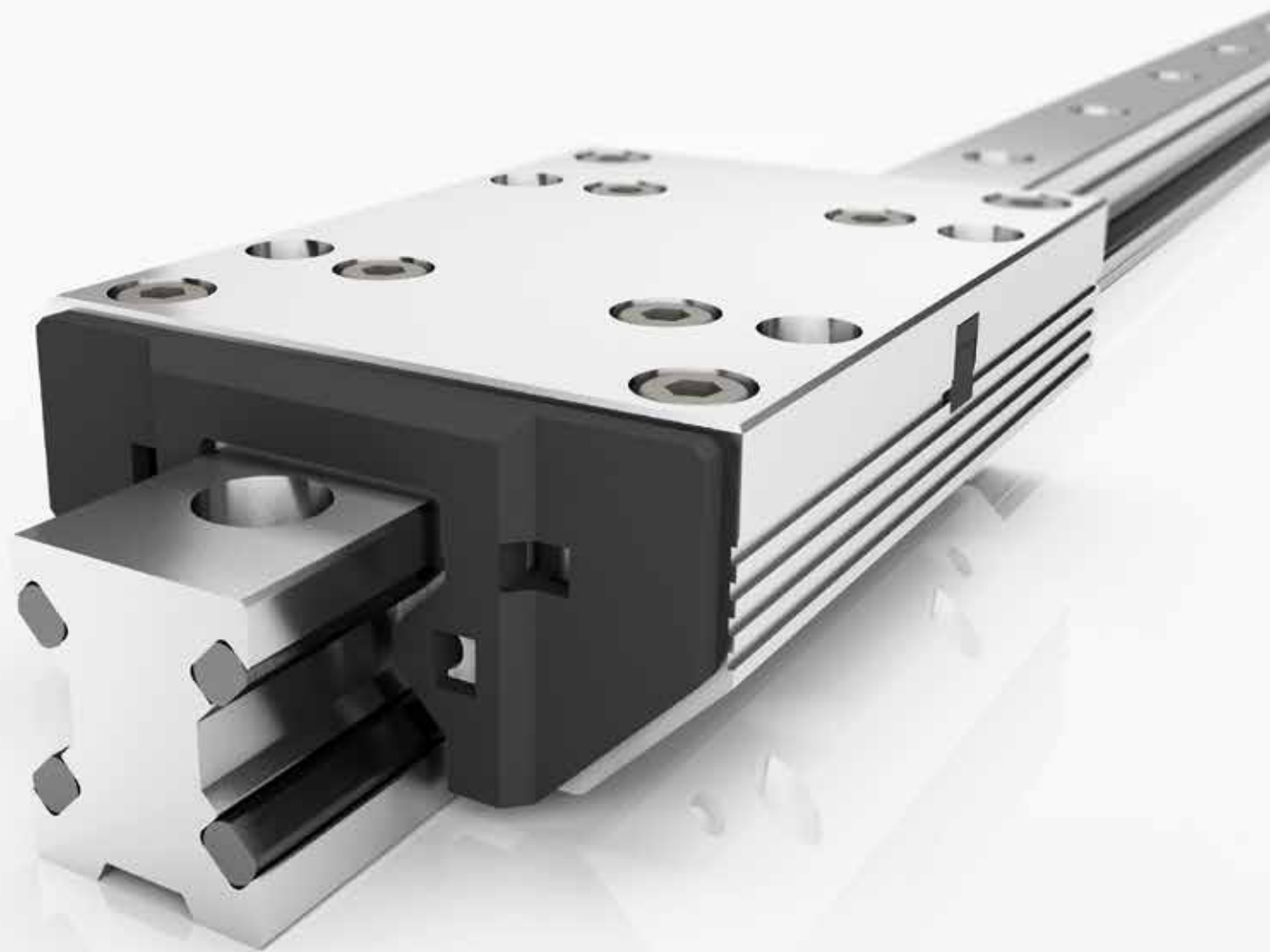

Linear guides

Type	Characteristic	Page
FDA	Aluminium roller guide/Standard	88–89
FDB	Aluminium roller guide/LowCost	90–91
FDC	Aluminium roller guide/Non-Corrosive	92–93
FDD	Aluminium roller guide/Non-Magnetic	94–95
FDE	Aluminium roller guide/Lubricant-Free	96–97
FDF	Aluminium roller guide/Non-Corrosive LowCost	98–99
FDH	Aluminium roller guide/Highly Dynamic	100–101



Linear guides

Aluminium roller guide Franke Dynamic

Type FDA/Standard

Cassette + double rail

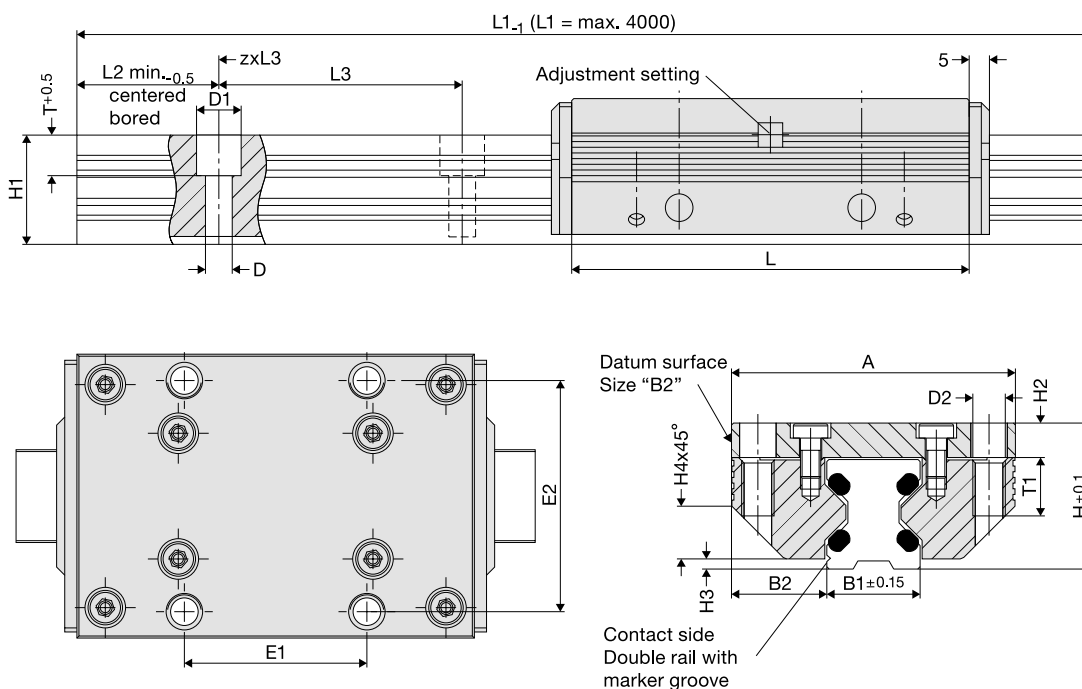

Dimensions

Size	Dimensions mm																		
	A	L	H	B1	B2	D	D1	D2	E1	E2	H1	H2	H3	H4	L2	L3	T	T1	
12	37	64	19	12.0	12.50	3.4	6	M 4	25	30	14.7	4.0	1.4	5.5	10	40	5.5	8	
15	47	78	24	15.5	15.75	4.5	8	M 5	30	38	18.7	5.0	2.0	8.0	10	60	6.0	10	
20	63	92	30	21.0	21.00	5.5	10	M 6	40	53	22.6	7.0	2.0	11.0	10	60	8.0	12	
25	70	98	36	23.0	23.50	6.6	11	M 8	45	57	27.0	8.5	2.5	13.0	10	60	10.0	16	
35	100	135	48	32.0	34.00	9.0	15	M 10	62	82	37.0	10.5	3.5	20.0	12	80	11.5	20	
45	120	165	60	45.0	37.50	11.0	18	M 12	80	100	46.0	13.5	4.0	22.0	16	105	14.5	24	

Load ratings, weight

Size	Load rating N		Moment load ratings*, cassette Nm					Weight kg	
	C	C ₀	M _{0cx}	M _{cx}	M _{0cy} /M _{0cz}	M _{cy} /M _{cz}	Cassette	Rail/m	
12	2800	3000	27	25	43	40	0.1	0.4	
15	4200	3400	37	45	58	72	0.2	0.8	
20	5400	5400	76	76	111	111	0.4	0.9	
25	9000	10100	158	142	222	198	0.5	1.8	
35	12500	18000	423	294	559	388	1.4	3.2	
45	21200	25900	827	678	983	806	2.5	5.5	

Order numbers

Order no.	Order code
Cassette	Double rail
84494A	e.g. FDA 25 D 1500
84396A	
84441A	
84363A	
84364A	
84365A	Size

*See technical information for more information on moment load ratings

**Guide rails in one piece up to 4000 mm. Longer stroke lengths are coupled.

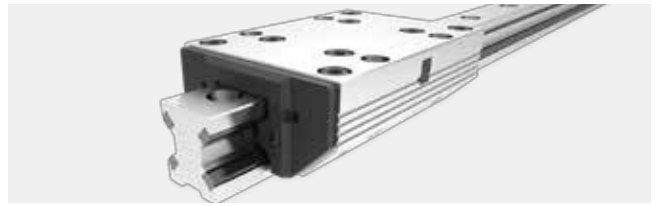

Pair of roller shows + pair of single rails

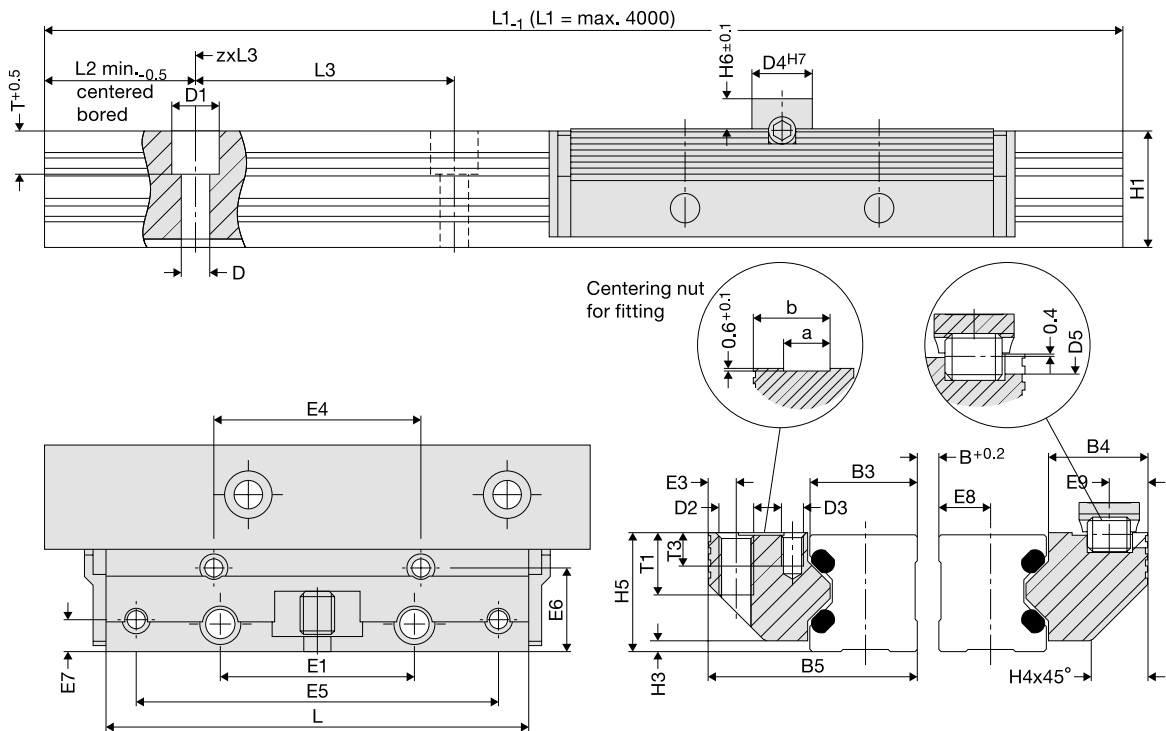

Dimensions

Size	Dimensions mm																		
	B5	H5	B3	B4	D3	D4	D5	E3	E4	E5	E6	E7	E8	E9	H6	T3	a	b	
12	24.4	15.0	12.00	11.9	M 3	8	3	3.4	29	57	9.7	3.4	5.5	4.9	4	6.0	4.5	9.5	
15	30.9	19.0	15.25	15.2	M 4	10	4	4.4	34	68	12.4	4.9	7.0	5.9	5	7.5	5.0	12.5	
20	40.9	23.0	20.00	20.4	M 5	10	4	4.9	42	80	16.9	5.9	9.5	5.9	5	8.0	7.5	16.0	
25	48.4	27.5	25.00	22.9	M 5	14	6	6.4	48	84	19.4	7.4	12.0	8.9	7	5.0	10.5	17.5	
35	68.9	37.5	35.00	32.9	M 6	14	6	8.9	67	117	28.4	8.9	17.0	8.9	7	7.5	12.5	26.0	
45	82.4	46.5	45.00	36.4	M 8	14	6	9.9	83	146	30.9	9.9	22.0	8.9	7	9.5	15.5	31.0	

Load ratings, weight

Size	Load rating N		Moment load rating* RSP Nm					Weight kg	
	C	C ₀	M _{0cx}	M _{cx}	M _{0cy} /M _{0cz}	M _{cy} /M _{cz}	RSP	Rail/m	
12	2800	3000	1.5 (B+30.3)	1.4 (B+30.3)	43	40	0.07	0.4	
15	4200	3400	1.7 (B+36.5)	2.1 (B+36.5)	58	72	0.12	0.8	
20	5400	5400	2.7 (B+47.0)	2.7 (B+47.0)	111	111	0.23	1.0	
25	9000	10100	5.0 (B+58.4)	4.5 (B+58.4)	222	198	0.34	1.9	
35	12500	18000	9.0 (B+85.0)	6.3 (B+85.0)	559	388	0.99	3.5	
45	21200	25900	12.9 (B+109.0)	10.6 (B+109.0)	983	806	1.79	5.6	

*See technical information for more information on moment load ratings

Order numbers

Order no.	Order code
RSP	Pair of single rails
84495A	e.g. FDA 25 E 1500
84395A	
84442A	
84367A	
84368A	
84369A	Single rail
84369A	Size

**Guide rails in one piece up to 4000 mm. Longer stroke lengths are coupled.

Linear guides

Aluminium roller guide Franke Dynamic

Type FDB/LowCost

Cassette + double rail

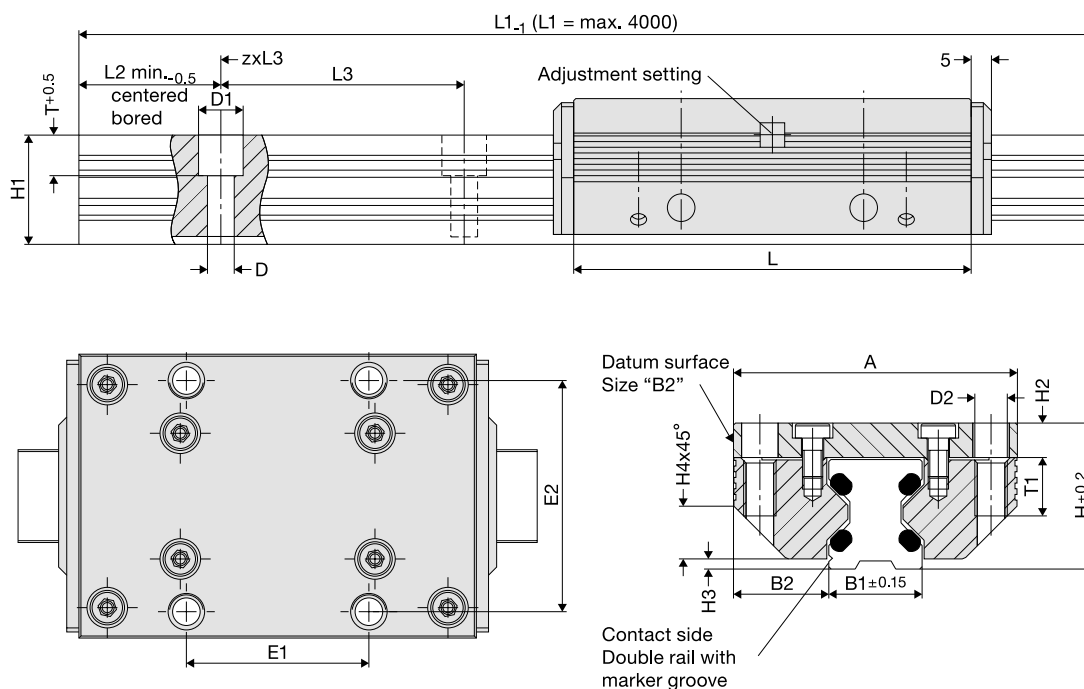

Dimensions

Size	Dimensions mm																		
	A	L	H	B1	B2	D	D1	D2	E1	E2	H1	H2	H3	H4	L2	L3	T	T1	
12	37	64	19	12.0	12.50	3.4	6	M 4	25	30	14.7	4.0	1.4	5.5	10	40	5.5	8	
15	47	78	24	15.5	15.75	4.5	8	M 5	30	38	18.7	5.0	2.0	8.0	10	60	6.0	10	
20	63	92	30	21.0	21.00	5.5	10	M 6	40	53	22.6	7.0	2.0	11.0	10	60	8.0	12	
25	70	98	36	23.0	23.50	6.6	11	M 8	45	57	27.0	8.5	2.5	13.0	10	60	10.0	16	
35	100	135	48	32.0	34.00	9.0	15	M 10	62	82	37.0	10.5	3.5	20.0	12	80	11.5	20	
45	120	165	60	45.0	37.50	11.0	18	M 12	80	100	46.0	13.5	4.0	22.0	16	105	14.5	24	

Load ratings, weight

Size	Load rating N		Moment load ratings*, cassette Nm					Weight kg	
	C	C ₀	M _{0cx}	M _{cx}	M _{0cy} /M _{0cz}	M _{cy} /M _{cz}	Cassette	Rail/m	
12	620	170	1.6	5.7	2.4	8.9	0.1	0.4	
15	700	230	2.5	7.5	4.0	12.0	0.2	0.8	
20	940	300	4.0	13.0	6.0	19.0	0.4	0.9	
25	1500	700	11.0	23.0	15.0	32.0	0.5	1.8	
35	3100	1400	32.0	72.0	42.0	95.0	1.4	3.2	
45	6300	2700	86.0	200.0	103.0	238.0	2.5	5.5	

Order numbers

Order no.	Order code
Cassette	Double rail
84494L	e.g. FDB 25 D 1500
84396L	
84441L	
84363L	
84364L	
84365L	Size

*See technical information for more information on moment load ratings

**Guide rails in one piece up to 4000 mm. Longer stroke lengths are coupled.

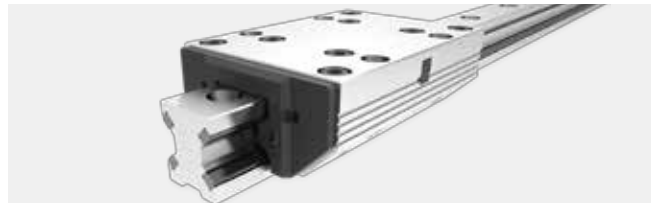

Pair of roller shows + pair of single rails

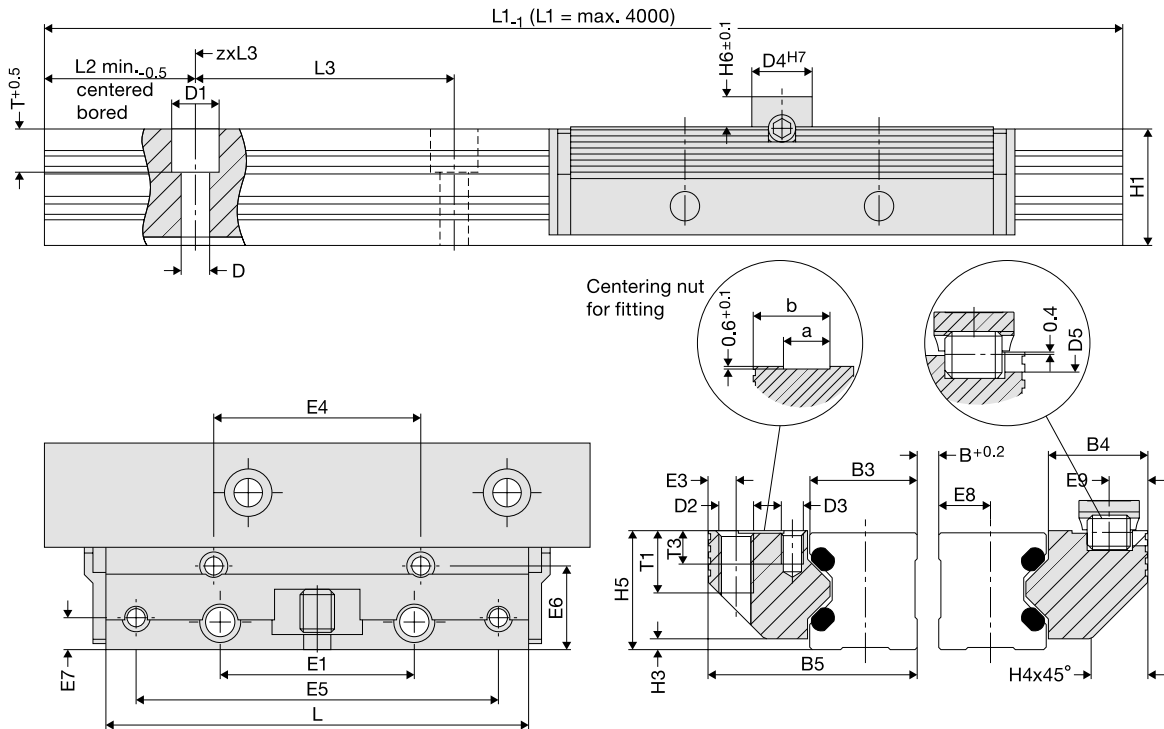

Dimensions

Size	Dimensions mm																		
	B5	H5	B3	B4	D3	D4	D5	E3	E4	E5	E6	E7	E8	E9	H6	T3	a	b	
12	24.4	15.0	12.00	11.9	M 3	8	3	3.4	29	57	9.7	3.4	5.5	4.9	4	6.0	4.5	9.5	
15	30.9	19.0	15.25	15.2	M 4	10	4	4.4	34	68	12.4	4.9	7.0	5.9	5	7.5	5.0	12.5	
20	40.9	23.0	20.00	20.4	M 5	10	4	4.9	42	80	16.9	5.9	9.5	5.9	5	8.0	7.5	16.0	
25	48.4	27.5	25.00	22.9	M 5	14	6	6.4	48	84	19.4	7.4	12.0	8.9	7	5.0	10.5	17.5	
35	68.9	37.5	35.00	32.9	M 6	14	6	8.9	67	117	28.4	8.9	17.0	8.9	7	7.5	12.5	26.0	
45	82.4	46.5	45.00	36.4	M 8	14	6	9.9	83	146	30.9	9.9	22.0	8.9	7	9.5	15.5	31.0	

Load ratings, weight

Size	Load rating N		Moment load rating* RSP Nm					Weight kg	
	C	C ₀	M _{0cx}	M _{cx}	M _{0cy} /M _{0cz}	M _{cy} /M _{cz}	RSP	Rail/m	
12	620	170	0.08 (B+30.3)	0.30 (B+30.3)	2.4	8.9	0.07	0.4	
15	700	230	0.10 (B+36.5)	0.35 (B+36.5)	4.0	12.0	0.12	0.8	
20	940	300	0.15 (B+47.0)	0.50 (B+47.0)	6.0	19.0	0.23	1.0	
25	1500	700	0.35 (B+58.4)	0.70 (B+58.4)	15.0	32.0	0.34	1.9	
35	3100	1400	0.70 (B+85.0)	1.50 (B+85.0)	42.0	95.0	0.99	3.5	
45	6300	2700	1.40 (B+109.0)	3.10 (B+109.0)	103.0	238.0	1.79	5.6	

*See technical information for more information on moment load ratings

Order numbers

Order no.	Order code
RSP	Pair of single rails
84495L	e.g. FDB 25 E 1500
84395L	
84442L	
84367L	
84368L	
84369L	Single rail

**Guide rails in one piece up to 4000 mm. Longer stroke lengths are coupled.

Linear guides

Aluminium roller guide Franke Dynamic

Type FDC/Non-Corrosive

Cassette + double rail

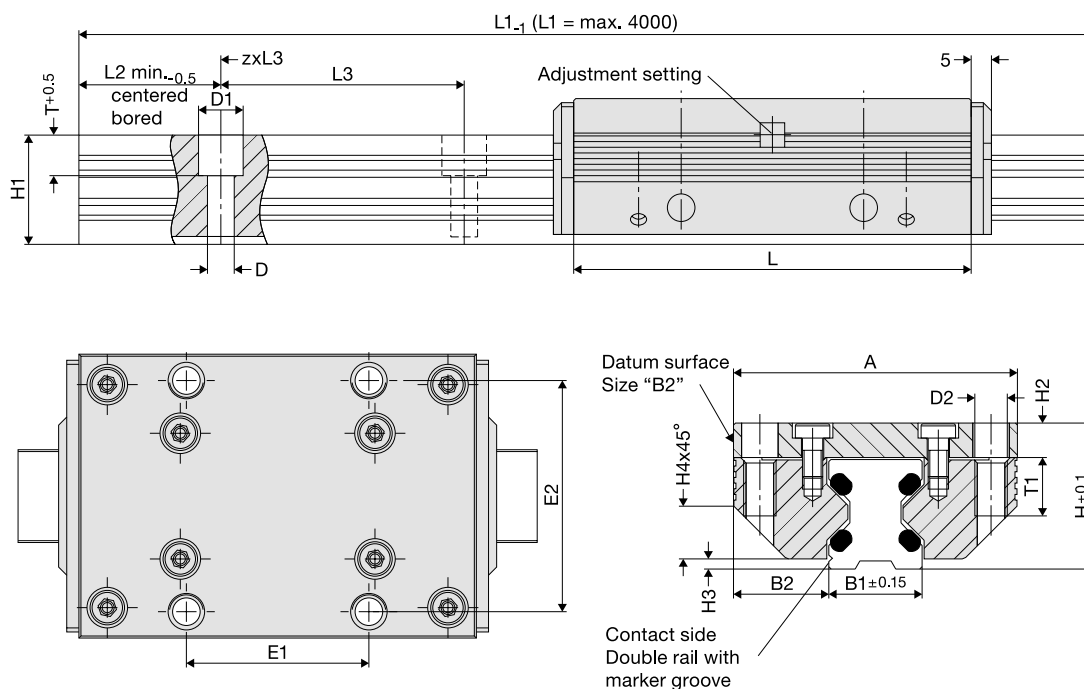

Dimensions

Size	Dimensions mm																		
	A	L	H	B1	B2	D	D1	D2	E1	E2	H1	H2	H3	H4	L2	L3	T	T1	
12	37	64	19	12.0	12.50	3.4	6	M 4	25	30	14.7	4.0	1.4	5.5	10	40	5.5	8	
15	47	78	24	15.5	15.75	4.5	8	M 5	30	38	18.7	5.0	2.0	8.0	10	60	6.0	10	
20	63	92	30	21.0	21.00	5.5	10	M 6	40	53	22.6	7.0	2.0	11.0	10	60	8.0	12	
25	70	98	36	23.0	23.50	6.6	11	M 8	45	57	27.0	8.5	2.5	13.0	10	60	10.0	16	
35	100	135	48	32.0	34.00	9.0	15	M 10	62	82	37.0	10.5	3.5	20.0	12	80	11.5	20	
45	120	165	60	45.0	37.50	11.0	18	M 12	80	100	46.0	13.5	4.0	22.0	16	105	14.5	24	

Load ratings, weight

Size	Load rating N		Moment load ratings*, cassette Nm					Weight kg	
	C	C ₀	M _{0cx}	M _{cx}	M _{0cy} /M _{0cz}	M _{cy} /M _{cz}	Cassette	Rail/m	
12	1100	1200	11	10	17	16	0.1	0.4	
15	2700	3000	33	29	52	46	0.2	0.8	
20	4300	5000	71	61	103	89	0.4	0.9	
25	5800	8300	132	92	184	128	0.5	1.8	
35	10000	14500	343	237	452	312	1.4	3.2	
45	17000	20400	651	542	774	645	2.5	5.5	

Order numbers

Order no.	Order code
Cassette	Double rail
84494AN	e.g. FDC 25 D 1500
84396AN	
84441AN	
84363AN	
84364AN	
84365AN	Size

*See technical information for more information on moment load ratings

**Guide rails in one piece up to 4000 mm. Longer stroke lengths are coupled.

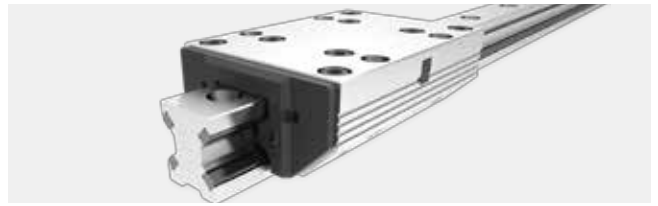

Pair of roller shows + pair of single rails

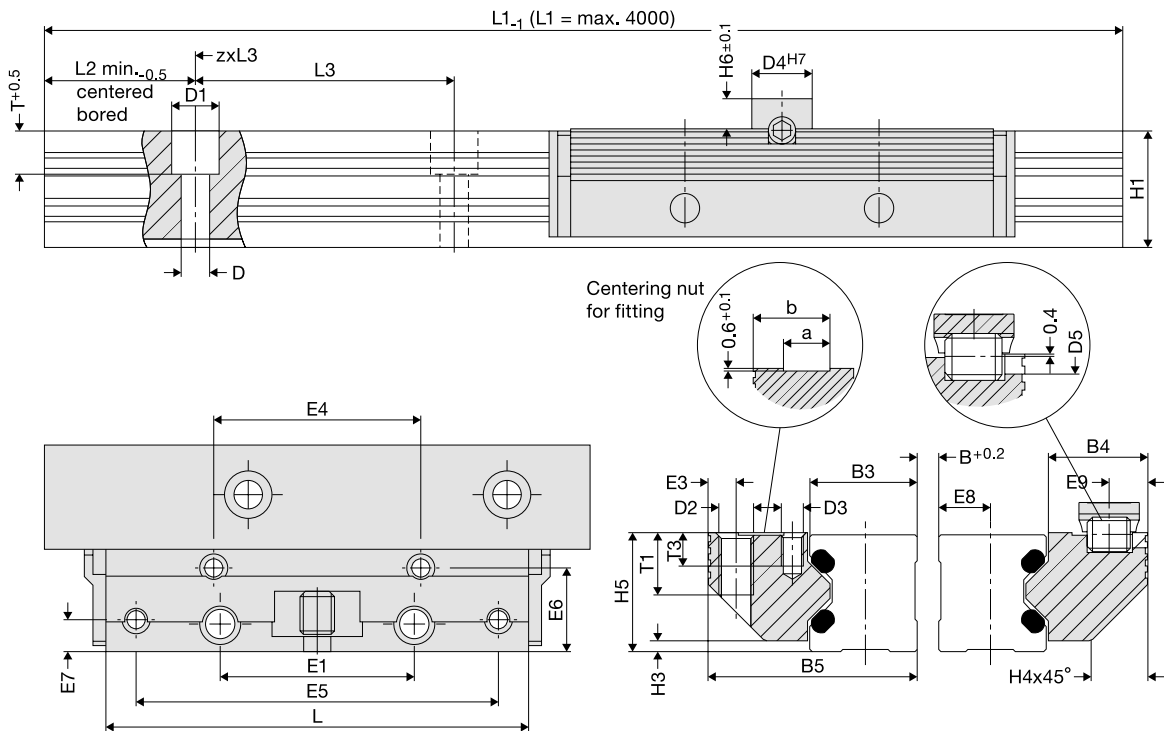

Dimensions

Size	Dimensions mm																		
	B5	H5	B3	B4	D3	D4	D5	E3	E4	E5	E6	E7	E8	E9	H6	T3	a	b	
12	24.4	15.0	12.00	11.9	M 3	8	3	3.4	29	57	9.7	3.4	5.5	4.9	4	6.0	4.5	9.5	
15	30.9	19.0	15.25	15.2	M 4	10	4	4.4	34	68	12.4	4.9	7.0	5.9	5	7.5	5.0	12.5	
20	40.9	23.0	20.00	20.4	M 5	10	4	4.9	42	80	16.9	5.9	9.5	5.9	5	8.0	7.5	16.0	
25	48.4	27.5	25.00	22.9	M 5	14	6	6.4	48	84	19.4	7.4	12.0	8.9	7	5.0	10.5	17.5	
35	68.9	37.5	35.00	32.9	M 6	14	6	8.9	67	117	28.4	8.9	17.0	8.9	7	7.5	12.5	26.0	
45	82.4	46.5	45.00	36.4	M 8	14	6	9.9	83	146	30.9	9.9	22.0	8.9	7	9.5	15.5	31.0	

Load ratings, weight

Size	Load rating		Moment load rating* RSP					Weight	
	N	C	Nm					RSP	Rail/m
			M_{0cx}	M_{cx}	M_{0cy}/M_{0cz}	M_{cy}/M_{cz}	C ₀		
12	1100	1200	0.6 (B+30.3)	0.6 (B+30.3)	17	16	0.07	0.4	
15	2700	3000	1.5 (B+36.5)	1.4 (B+36.5)	52	46	0.12	0.8	
20	4300	5000	2.5 (B+47.0)	2.2 (B+47.0)	103	89	0.23	1.0	
25	5800	8300	4.2 (B+58.4)	2.9 (B+58.4)	184	128	0.34	1.9	
35	10000	14500	7.3 (B+85.0)	5.0 (B+85.0)	452	312	0.99	3.5	
45	17000	20400	10.2 (B+109.0)	8.5 (B+109.0)	774	645	1.79	5.6	

*See technical information for more information on moment load ratings

Order numbers

Order no.	Order code
RSP	Pair of single rails
84495AN	e.g. FDC 25 E 1500
84395AN	
84442AN	
84367AN	
84368AN	
84369AN	
84369AN	Single rail

**Guide rails in one piece up to 4000 mm. Longer stroke lengths are coupled.

Linear guides

Aluminium roller guide Franke Dynamic

Type FDD/Non-Magnetic

Cassette + double rail

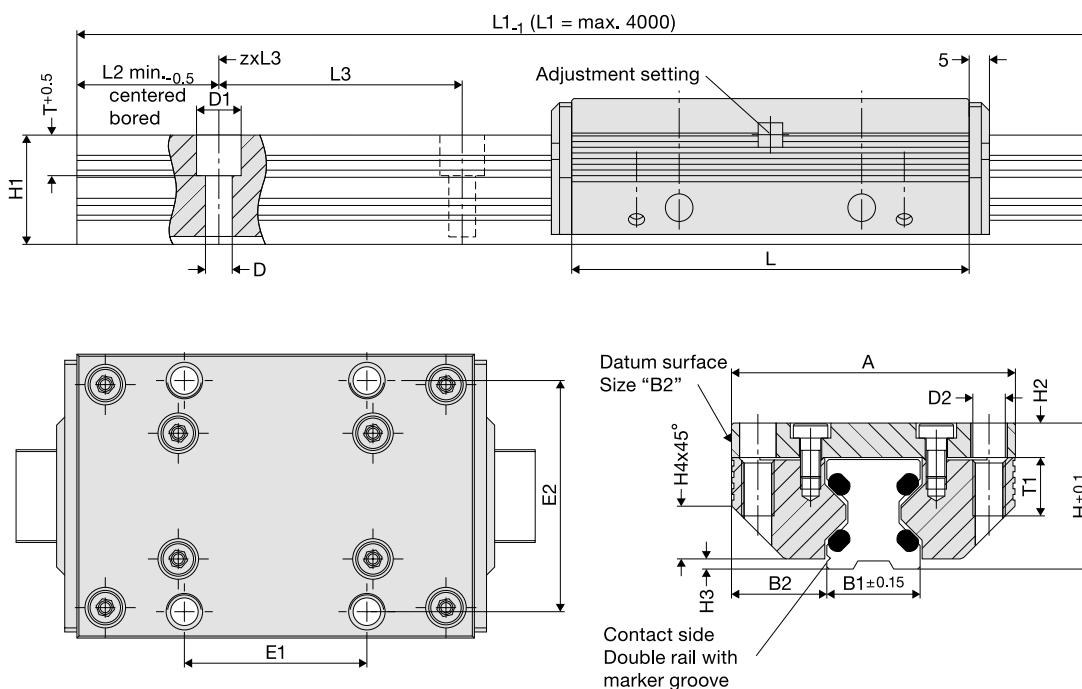

Dimensions

Size	Dimensions																	
	mm																	
25	A	L	H	B1	B2	D	D1	D2	E1	E2	H1	H2	H3	H4	L2	L3	T	T1
25	70	98	36	23.0	23.50	6.6	11	M 8	45	57	27.0	8.5	2.5	13.0	10	60	10.0	16

Load ratings, weight

Size	Load rating		Moment load ratings*, cassette				Weight	
	N	C	Nm				kg	
25	1200	1600	M_{0cx}	M_{cx}	M_{0cy}/M_{0cz}	M_{cy}/M_{cz}	Cassette	Rail/m
25	1200	1600	25	18	35	25	0.5	1.8

Order numbers

Order no.	Order code
Cassette	Double rail
84363P	e.g. FDD 25 D 1500
	Size
	Type
	Length in mm**
	Double rail

*See technical information for more information on moment load ratings

**Guide rails in one piece up to 4000 mm. Longer stroke lengths are coupled.

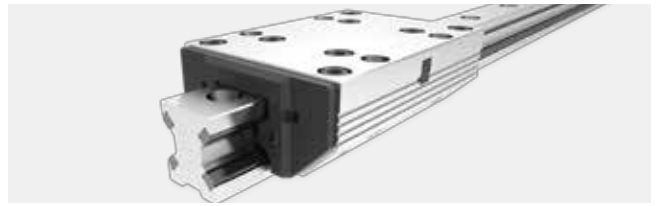

Pair of roller shows + pair of single rails

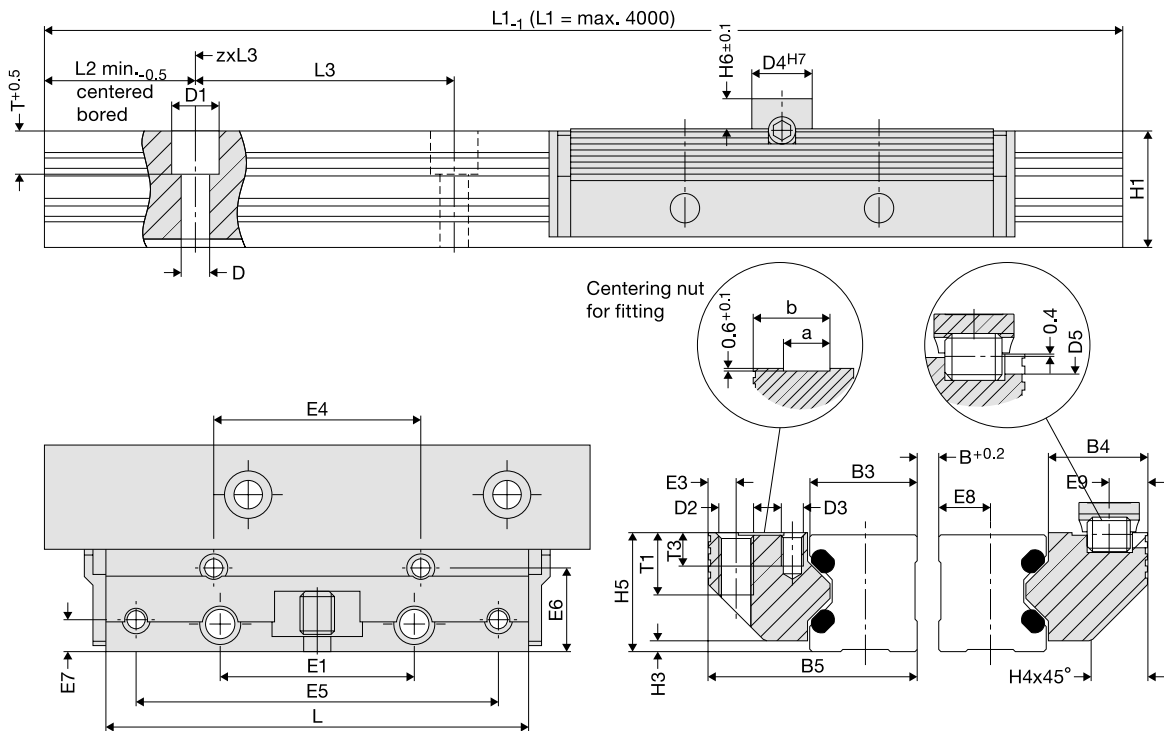

Dimensions

Size	Dimensions																	
	B5	H5	B3	B4	D3	D4	D5	E3	E4	E5	E6	E7	E8	E9	H6	T3	a	b
25	48.4	27.5	25.00	22.9	M 5	14	6	6.4	48	84	19.4	7.4	12.0	8.9	7	5.0	10.5	17.5

Load ratings, weight

Size	Load rating		Moment load rating* RSP				Weight	
	N	C	Nm				RSP	kg
	C	C ₀	M _{0cx}	M _{cx}	M _{0cy} /M _{0cz}	M _{cy} /M _{cz}	RSP	Rail/m
25	1200	1600	0.8 (B+58.4)	0.6 (B+58.4)	35	25	0.34	1.9

Order numbers

Order no.	Order code
RSP	Pair of single rails
84367P	e.g. FDD 25 E 1500
	<ul style="list-style-type: none"> Type Size Length in mm** Single rail

*See technical information for more information on moment load ratings

**Guide rails in one piece up to 4000 mm. Longer stroke lengths are coupled.

Linear guides

Aluminium roller guide Franke Dynamic

Type FDE/Lubricant-Free

Cassette + double rail

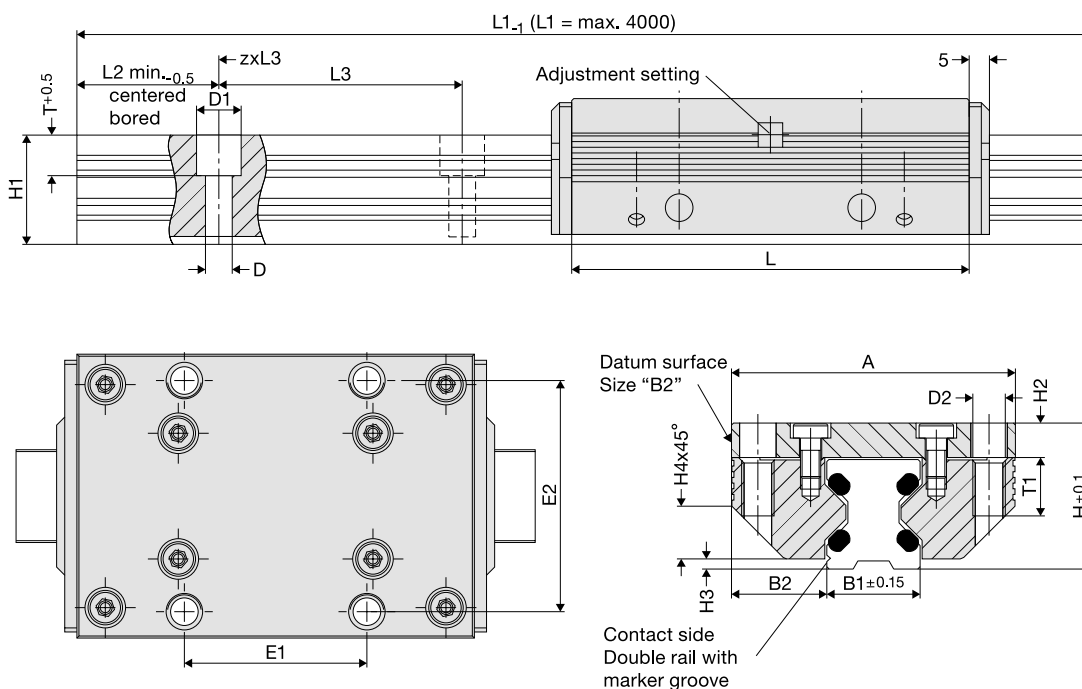

Dimensions

Size	Dimensions mm																		
	A	L	H	B1	B2	D	D1	D2	E1	E2	H1	H2	H3	H4	L2	L3	T	T1	
12	37	64	19	12.0	12.50	3.4	6	M 4	25	30	14.7	4.0	1.4	5.5	10	40	5.5	8	
15	47	78	24	15.5	15.75	4.5	8	M 5	30	38	18.7	5.0	2.0	8.0	10	60	6.0	10	
20	63	92	30	21.0	21.00	5.5	10	M 6	40	53	22.6	7.0	2.0	11.0	10	60	8.0	12	
25	70	98	36	23.0	23.50	6.6	11	M 8	45	57	27.0	8.5	2.5	13.0	10	60	10.0	16	
35	100	135	48	32.0	34.00	9.0	15	M 10	62	82	37.0	10.5	3.5	20.0	12	80	11.5	20	
45	120	165	60	45.0	37.50	11.0	18	M 12	80	100	46.0	13.5	4.0	22.0	16	105	14.5	24	

Load ratings, weight

Size	Load rating N		Moment load ratings*, cassette Nm					Weight kg	
	C	C ₀	M _{0cx}	M _{cx}	M _{0cy} /M _{0cz}	M _{cy} /M _{cz}	Cassette	Rail/m	
12	350	400	4	3	6	5	0.1	0.4	
15	600	700	8	6	12	10	0.2	0.8	
20	700	900	12	9	17	14	0.4	0.9	
25	1200	1600	25	18	35	25	0.5	1.8	
35	2000	2500	58	44	76	58	1.4	3.2	
45	4400	5500	180	140	210	170	2.5	5.5	

Order numbers

Order no.	Order code
Cassette	Double rail
84494T	e.g. FDE 25 D 1500
84396T	
84441T	
84363T	
84364T	
84365T	Size

*See technical information for more information on moment load ratings

**Guide rails in one piece up to 4000 mm. Longer stroke lengths are coupled.

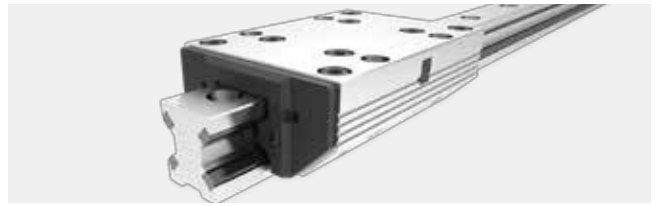

Pair of roller shows + pair of single rails

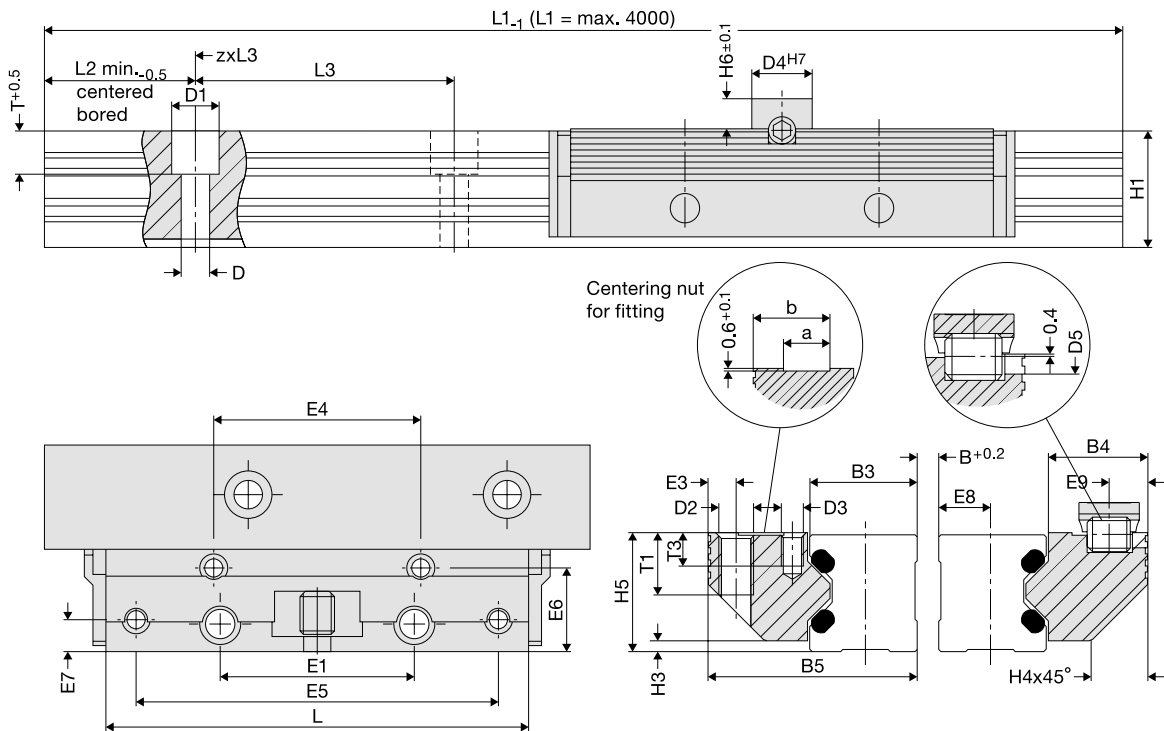

Dimensions

Size	Dimensions mm																		
	B5	H5	B3	B4	D3	D4	D5	E3	E4	E5	E6	E7	E8	E9	H6	T3	a	b	
12	24.4	15.0	12.00	11.9	M 3	8	3	3.4	29	57	9.7	3.4	5.5	4.9	4	6.0	4.5	9.5	
15	30.9	19.0	15.25	15.2	M 4	10	4	4.4	34	68	12.4	4.9	7.0	5.9	5	7.5	5.0	12.5	
20	40.9	23.0	20.00	20.4	M 5	10	4	4.9	42	80	16.9	5.9	9.5	5.9	5	8.0	7.5	16.0	
25	48.4	27.5	25.00	22.9	M 5	14	6	6.4	48	84	19.4	7.4	12.0	8.9	7	5.0	10.5	17.5	
35	68.9	37.5	35.00	32.9	M 6	14	6	8.9	67	117	28.4	8.9	17.0	8.9	7	7.5	12.5	26.0	
45	82.4	46.5	45.00	36.4	M 8	14	6	9.9	83	146	30.9	9.9	22.0	8.9	7	9.5	15.5	31.0	

Load ratings, weight

Size	Load rating N		Moment load rating* RSP Nm					Weight kg	
	C	C ₀	M _{0cx}	M _{cx}	M _{0cy} /M _{0cz}	M _{cy} /M _{cz}	RSP	Rail/m	
12	350	400	0.20 (B+30.3)	0.20 (B+30.3)	6	5	0.07	0.4	
15	600	700	0.35 (B+36.5)	0.30 (B+36.5)	12	10	0.12	0.8	
20	700	900	0.40 (B+47.0)	0.33 (B+47.0)	17	14	0.23	1.0	
25	1200	1600	0.80 (B+58.4)	0.60 (B+58.4)	35	25	0.34	1.9	
35	2000	2500	1.20 (B+85.0)	0.90 (B+85.0)	76	58	0.99	3.5	
45	4400	5500	2.70 (B+109.0)	2.20 (B+109.0)	210	170	1.79	5.6	

*See technical information for more information on moment load ratings

Order numbers

Order no.	Order code
RSP	Pair of single rails
84495T	e.g. FDE 25 E 1500
84395T	
84442T	
84367T	
84368T	
84369T	Single rail
84369T	Size

**Guide rails in one piece up to 4000 mm. Longer stroke lengths are coupled.

Linear guides

Aluminium roller guide Franke Dynamic

Type FDG/Non-Corrosive LowCost

Cassette + double rail

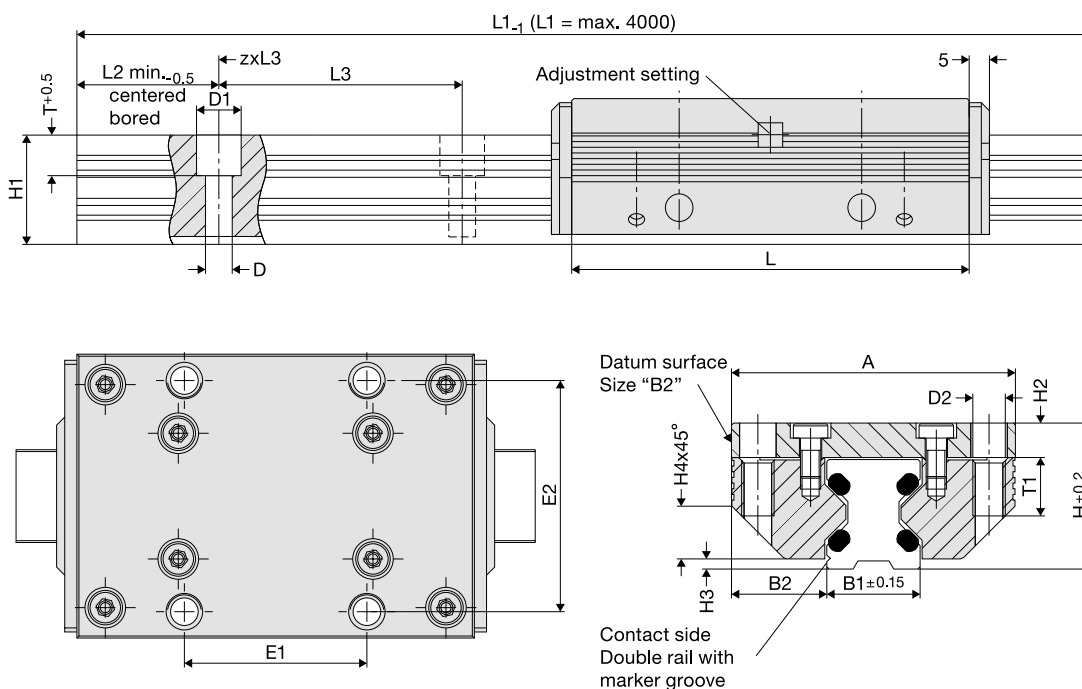

Dimensions

Size	Dimensions mm																		
	A	L	H	B1	B2	D	D1	D2	E1	E2	H1	H2	H3	H4	L2	L3	T	T1	
12	37	64	19	12.0	12.50	3.4	6	M 4	25	30	14.7	4.0	1.4	5.5	10	40	5.5	8	
15	47	78	24	15.5	15.75	4.5	8	M 5	30	38	18.7	5.0	2.0	8.0	10	60	6.0	10	
20	63	92	30	21.0	21.00	5.5	10	M 6	40	53	22.6	7.0	2.0	11.0	10	60	8.0	12	
25	70	98	36	23.0	23.50	6.6	11	M 8	45	57	27.0	8.5	2.5	13.0	10	60	10.0	16	
35	100	135	48	32.0	34.00	9.0	15	M 10	62	82	37.0	10.5	3.5	20.0	12	80	11.5	20	
45	120	165	60	45.0	37.50	11.0	18	M 12	80	100	46.0	13.5	4.0	22.0	16	105	14.5	24	

Load ratings, weight

Size	Load rating N		Moment load ratings*, cassette Nm					Weight kg	
	C	C ₀	M _{0cx}	M _{cx}	M _{0cy} /M _{0cz}	M _{cy} /M _{cz}	Cassette	Rail/m	
12	620	170	1.6	5.7	2.4	8.9	0.1	0.4	
15	700	230	2.5	7.5	4.0	12.0	0.2	0.8	
20	940	300	4.0	13.0	6.0	19.0	0.4	0.9	
25	1500	700	11.0	23.0	15.0	32.0	0.5	1.8	
35	3100	1400	32.0	72.0	42.0	95.0	1.4	3.2	
45	6300	2700	86.0	200.0	103.0	238.0	2.5	5.5	

Order numbers

Order no.	Order code
Cassette	Double rail
84494LN	e.g. FDG 25 D 1500
84396LN	
84441LN	
84363LN	
84364LN	
84365LN	Size

*See technical information for more information on moment load ratings

**Guide rails in one piece up to 4000 mm. Longer stroke lengths are coupled.

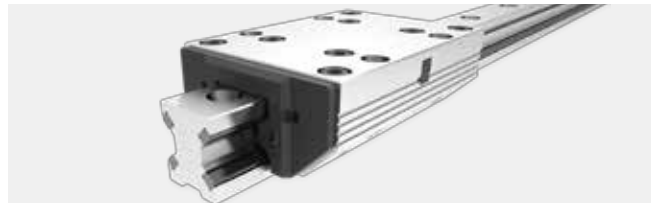

Pair of roller shows + pair of single rails

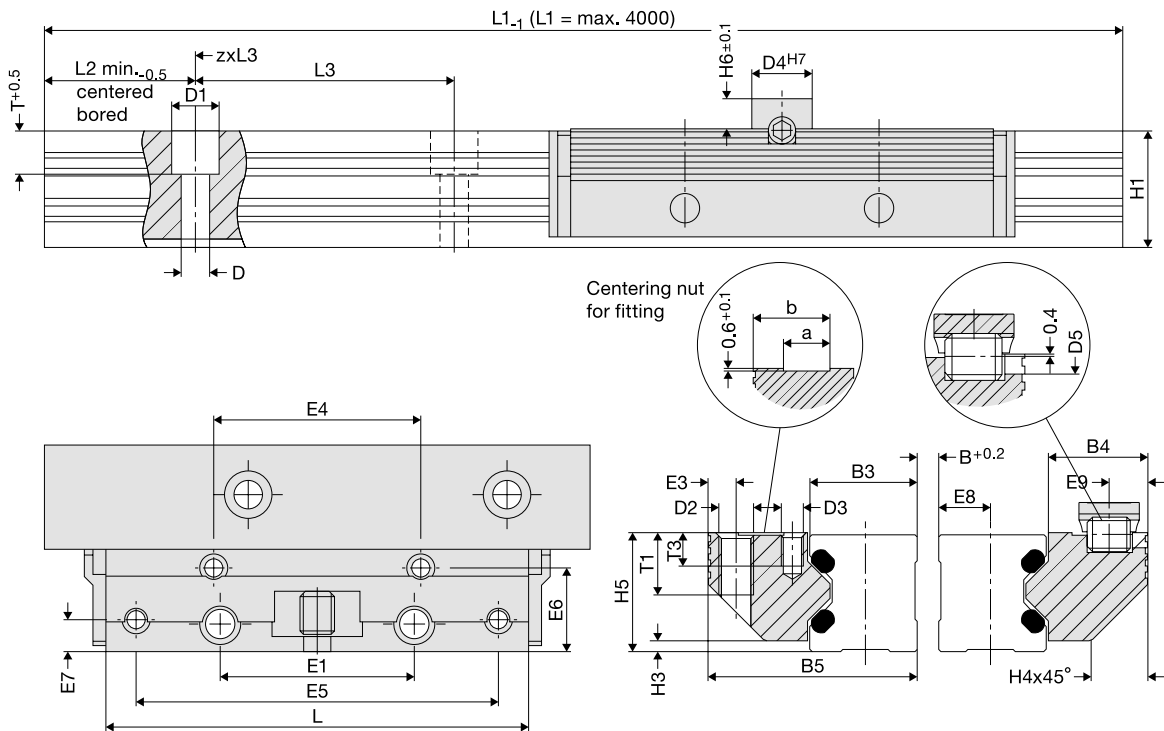

Dimensions

Size	Dimensions mm																		
	B5	H5	B3	B4	D3	D4	D5	E3	E4	E5	E6	E7	E8	E9	H6	T3	a	b	
12	24.4	15.0	12.00	11.9	M 3	8	3	3.4	29	57	9.7	3.4	5.5	4.9	4	6.0	4.5	9.5	
15	30.9	19.0	15.25	15.2	M 4	10	4	4.4	34	68	12.4	4.9	7.0	5.9	5	7.5	5.0	12.5	
20	40.9	23.0	20.00	20.4	M 5	10	4	4.9	42	80	16.9	5.9	9.5	5.9	5	8.0	7.5	16.0	
25	48.4	27.5	25.00	22.9	M 5	14	6	6.4	48	84	19.4	7.4	12.0	8.9	7	5.0	10.5	17.5	
35	68.9	37.5	35.00	32.9	M 6	14	6	8.9	67	117	28.4	8.9	17.0	8.9	7	7.5	12.5	26.0	
45	82.4	46.5	45.00	36.4	M 8	14	6	9.9	83	146	30.9	9.9	22.0	8.9	7	9.5	15.5	31.0	

Load ratings, weight

Size	Load rating		Moment load rating* RSP					Weight	
	N	C	Nm					RSP	kg
			M _{0cx}	M _{cx}	M _{0cy} /M _{0cz}	M _{cy} /M _{cz}	Rail/m		
12	620	170	0.08 (B+30.3)	0.30 (B+30.3)	2.4	8.9	0.07	0.4	
15	700	230	0.10 (B+36.5)	0.35 (B+36.5)	4.0	12.0	0.12	0.8	
20	940	300	0.15 (B+47.0)	0.50 (B+47.0)	6.0	19.0	0.23	1.0	
25	1500	700	0.35 (B+58.4)	0.70 (B+58.4)	15.0	32.0	0.34	1.9	
35	3100	1400	0.70 (B+85.0)	1.50 (B+85.0)	42.0	95.0	0.99	3.5	
45	6300	2700	1.40 (B+109.0)	3.10 (B+109.0)	103.0	238.0	1.79	5.6	

*See technical information for more information on moment load ratings

Order numbers

Order no.	Order code
RSP	Pair of single rails
84495LN	e.g. FDG 25 E 1500
84395LN	
84442LN	
84367LN	
84368LN	
84369LN	Single rail
84369LN	Size

**Guide rails in one piece up to 4000 mm. Longer stroke lengths are coupled.

Linear guides

Aluminium roller guide Franke Dynamic

Type FDH/Highly Dynamic

Cassette + double rail

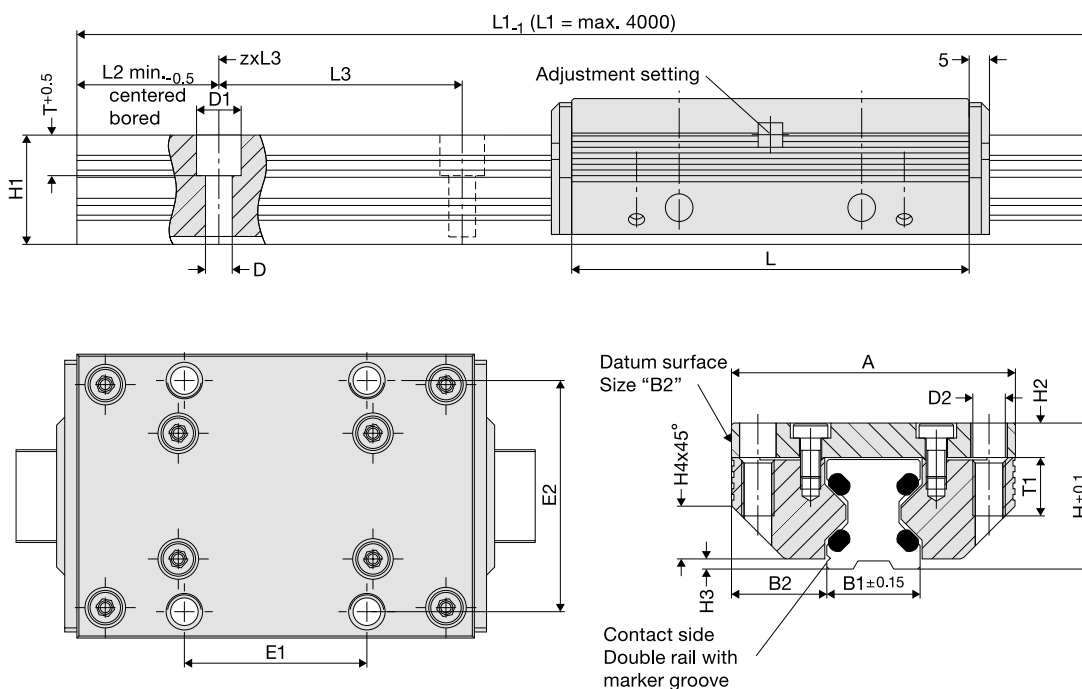

Dimensions

Size	Dimensions mm																		
	A	L	H	B1	B2	D	D1	D2	E1	E2	H1	H2	H3	H4	L2	L3	T	T1	
25	70	98	36	23.0	23.50	6.6	11	M 8	45	57	27.0	8.5	2.5	13.0	10	60	10.0	16	
35	100	135	48	32.0	34.00	9.0	15	M10	62	82	37.0	10.5	3.5	20.0	12	80	11.5	20	
45	120	165	60	45.0	37.50	11.0	18	M12	80	100	46.0	13.5	4.0	22.0	16	105	14.5	24	

Load ratings, weight

Size	Load rating N		Moment load ratings*, cassette Nm				Weight kg	
	C	C ₀	M _{0cx}	M _{cx}	M _{0cy} /M _{0cz}	M _{cy} /M _{cz}	Cassette	Rail/m
25	7500	3700	58	118	81	165	0.5	1.8
35	13400	8100	189	315	250	416	1.4	3.2
45	24300	14400	461	777	548	924	2.5	5.5

Order numbers

Order no.	Order code
Cassette	Double rail
84363S	e.g. FDH 25 D 1500
84364S	
84365S	

*See technical information for more information on moment load ratings

**Guide rails in one piece up to 4000 mm. Longer stroke lengths are coupled.

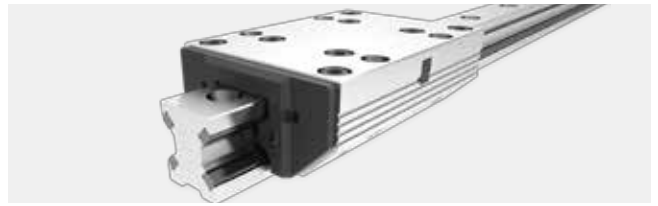

Pair of roller shows + pair of single rails

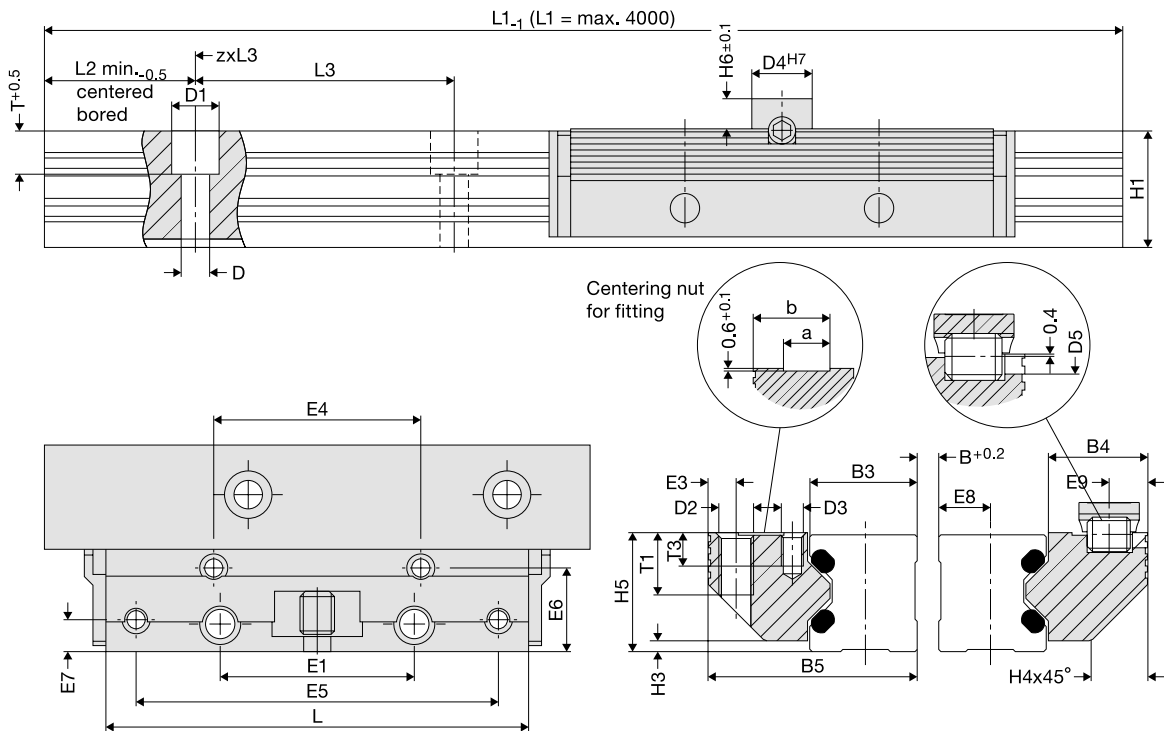

Dimensions

Size	Dimensions mm																		
	B5	H5	B3	B4	D3	D4	D5	E3	E4	E5	E6	E7	E8	E9	H6	T3	a	b	
25	48.4	27.5	25.00	22.9	M 5	14	6	6.4	48	84	19.4	7.4	12.0	8.9	7	5.0	10.5	17.5	
35	68.9	37.5	35.00	32.9	M 6	14	6	8.9	67	117	28.4	8.9	17.0	8.9	7	7.5	12.5	26.0	
45	82.4	46.5	45.00	36.4	M 8	14	6	9.9	83	146	30.9	9.9	22.0	8.9	7	9.5	15.5	31.0	

Load ratings, weight

Size	Load rating N		Moment load rating* RSP Nm				Weight kg	
	C	C ₀	M _{0cx}	M _{cx}	M _{0cy} /M _{0cz}	M _{cy} /M _{cz}	RSP	Rail/m
25	7500	3700	1.8 (B+58.4)	3.7 (B+58.4)	81	165	0.34	1.9
35	13400	8100	4.0 (B+85.0)	6.7 (B+85.0)	250	416	0.99	3.5
45	24300	14400	7.2 (B+109.0)	12.2 (B+109.0)	548	924	1.79	5.6

Order numbers

Order no.	Order code
RSP	Pair of single rails
84367S	e.g. FDH 25 E 1500
84368S	
84369S	

*See technical information for more information on moment load ratings

**Guide rails in one piece up to 4000 mm. Longer stroke lengths are coupled.



Linear tables/linear modules

Type	Characteristic	Page
FTB	Spindle drive	104–105
FTC	Outer guide/spindle/toothed belt drive	106–107
FTD	Inner guide/toothed belt drive	108–109
FTI	Inner guide/toothed belt drive	110–111
FTH	Outer guide/spindle/linear motor drive	112–115



Linear tables

Spindle drive

Type FTB

FTB06A/FTB06B

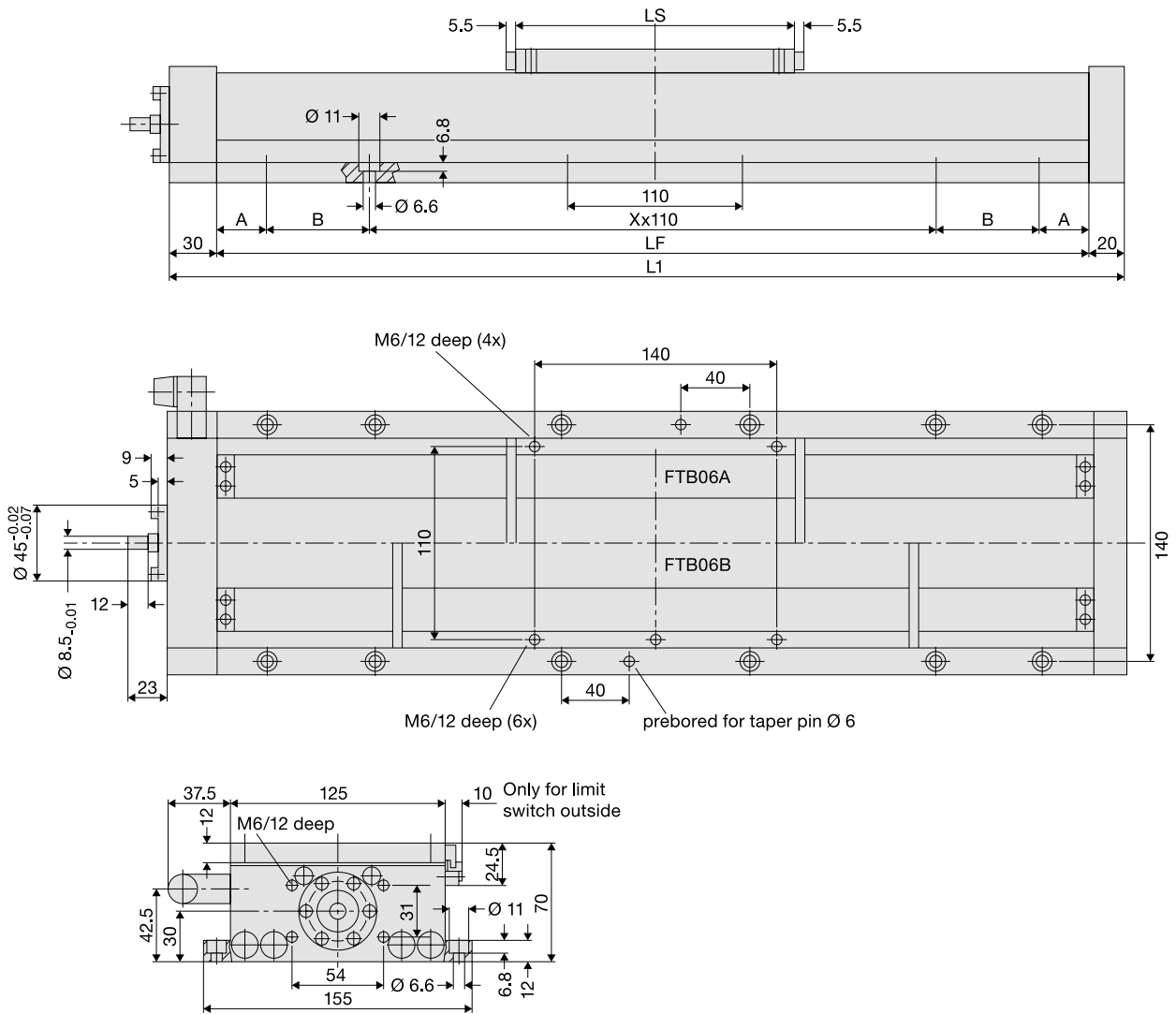

Dimensions

Stroke	Load rating N	Moments			Dimensions						Spindles		Travel speed		Spindle speed		Mounting Screws Number x size	Weight kg	Order no.
		M_{cx}	M_{cy}/M_{cz}	Nm	A	B	LS	LF	L1	X x 110	Ø	Rise	Stand.	Max.	Stand.	Max.			

FTB06A

100	15000	670	220	30.0	72.5	165	315	365	1 x 110	16	5	8	15	1600	3000	8 x M 6	6.4	92621A
200	15000	670	220	42.5		165	415	465	3 x 110	16	5	8	15	1600	3000	8 x M 6	7.5	92622A
300	15000	670	220	92.5		165	515	565	3 x 110	16	5	8	15	1600	3000	8 x M 6	8.6	92623A
400	15000	670	220	32.5		165	615	665	5 x 110	16	5	8	15	1600	3000	12 x M 6	9.7	92624A
500	15000	670	220	82.5		165	715	765	5 x 110	16	5	8	15	1600	3000	12 x M 6	10.8	92625A
700	15000	670	220	72.5		165	915	965	7 x 110	16	5	6	14	1200	2800	16 x M 6	13.0	92626A
1000	15000	670	220	30.0	82.5	165	1215	1265	9 x 110	16	10	12	25	1200	2500	24 x M 6	16.3	92627A
1200	15000	670	220	30.0	72.5	165	1415	1465	11 x 110	16	10	8	12	800	1200	28 x M 6	18.5	92628A

FTB06B

100	30000	1380	1930	50		280	430	480	3 x 110	16	5	8	15	1600	3000	8 x M 6	7.5	92630A
200	30000	1380	1930	100		280	530	580	3 x 110	16	5	8	15	1600	3000	8 x M 6	8.6	92631A
300	30000	1380	1930	40		280	630	680	5 x 110	16	5	8	15	1600	3000	12 x M 6	9.7	92632A
400	30000	1380	1930	90		280	730	780	5 x 110	16	5	8	15	1600	3000	12 x M 6	10.8	92633A
500	30000	1380	1930	30		280	830	880	7 x 110	16	5	8	15	1600	3000	16 x M 6	11.9	92634A
700	30000	1380	1930	20		280	1030	1080	9 x 110	16	5	6	14	1200	2800	20 x M 6	14.1	92635A
1000	30000	1380	1930	60		280	1330	1380	11 x 110	16	10	12	25	1200	2500	24 x M 6	17.4	92636A
1200	30000	1380	1930	50		280	1530	1580	13 x 110	16	10	8	12	800	1200	28 x M 6	19.6	92637A
1500	30000	1380	1930	90		280	1830	1880	15 x 110	16	10	6	8	600	800	32 x M 6	22.9	92638A

Performance overview

		FTB06A	FTB06B
Max. thrust force Fx	N	1500	1500
Basic torque (without load)	Nm	0.3	0.4
Positioning accuracy	mm	0.05/300	0.05/300
Repeatability	mm	≤ 0.01	≤ 0.01
Running accuracy	mm	± 0.03/300	± 0,03/300



Linear modules

Outer guide/spindle/toothed belt drive

Type FTC

FTC 15-25

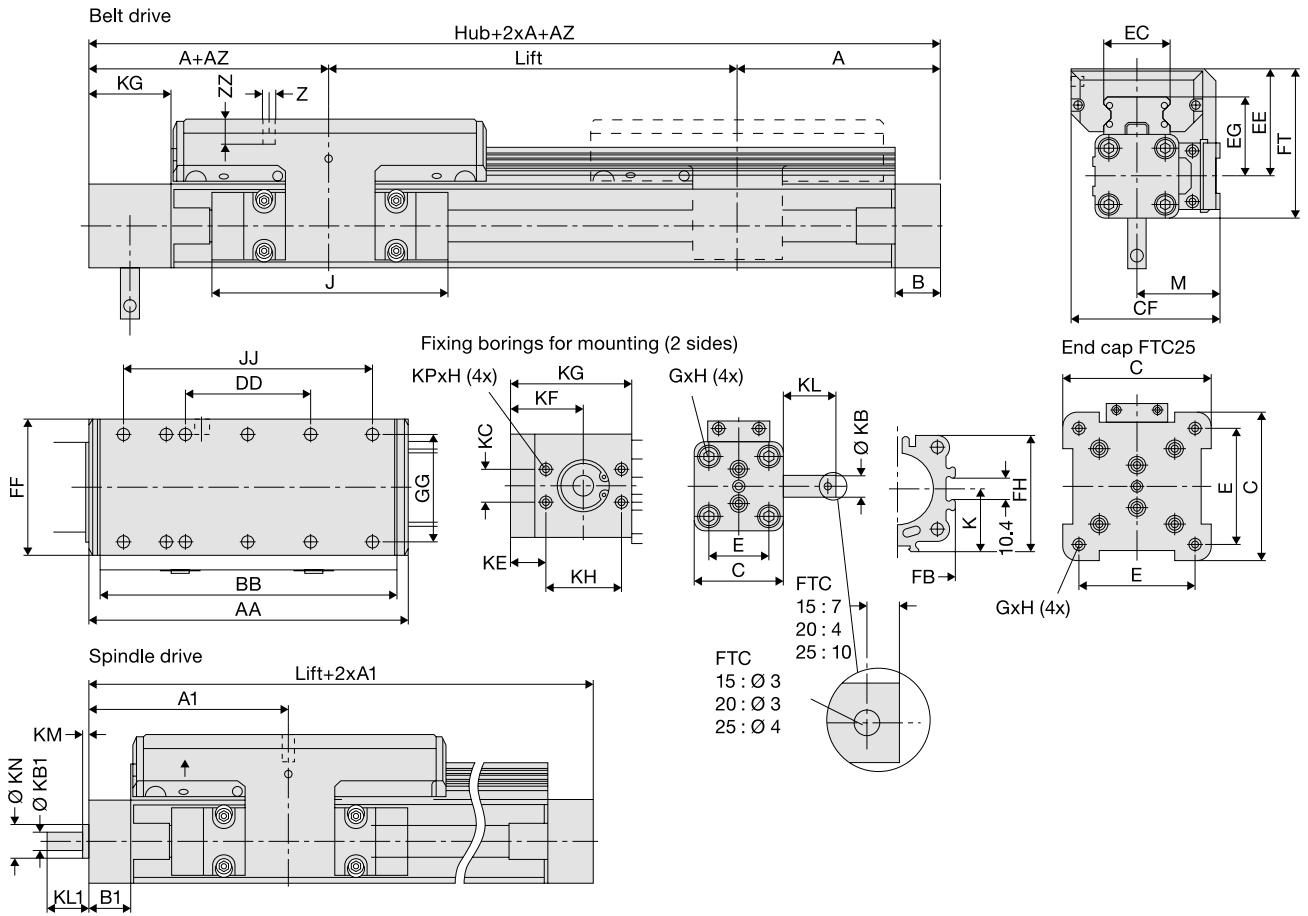

Size	Dimensions mm											
	A	A1	B	B1	C	E	G	H	J	K	M	Z
15	125	100	22	22.0	41	27	M 5	10	117	21.5	40.5	M 6
20	150	125	25	25.5	52	36	M 6	12	152	28.5	49.0	M 6
25	200	175	25	33.0	87	70	M 6	12	200	43.0	62.0	M 6

Size	Dimensions mm																										
	AA	AZ	BB	DD	CF	EC	EE	EG	FB	FF	FH	FT	GG	JJ	KB	KB1	KC	KE	KF	KG	KH	KL	KL1	KM	KN	KP	ZZ
15	154	10	144	60	72.5	32.5	53	39	40	64	39.5	73.5	50	120	10j6	6	15	22.0	37.0	57	30	24	17	2	13	M 5	12
20	197	11	187	80	91.0	42.0	62	48	52	84	51.7	88.0	64	160	10j6	10	18	17.5	36.5	61	38	26	31	2	20	M 6	12
25	276	24	266	120	117.0	63.0	75	57	76	110	77.0	118.5	90	240	16j6	15	32	23.5	48.5	85	50	34	43	3	28	M 8	16

Order numbers

Stroke mm	Order no.					
	FTC 15		FTC 20		FTC 25	
	Toothed belt	Spindles	Toothed belt	Spindles	Toothed belt	Spindles
100	92700A	92700S	92734A	92734S	92768A	92768S
200	92701A	92701S	92735A	92735S	92769A	92769S
300	92702A	92702S	92736A	92736S	92770A	92770S
400	92703A	92703S	92737A	92737S	92771A	92771S
500	92704A	92704S	92738A	92738S	92772A	92772S
600	92705A	92705S	92739A	92739S	92773A	92773S
700	92706A	92706S	92740A	92740S	92774A	92774S
800	92707A	92707S	92741A	92741S	92775A	92775S
900	92708A	92708S	92742A	92742S	92776A	92776S
1000	92709A	92709S	92743A	92743S	92777A	92777S
1100	92710A	92710S	92744A	92744S	92778A	92778S
1200	92711A		92745A	92745S	92779A	92779S
1300	92712A		92746A	92746S	92780A	92780S
1400	92713A		92747A	92747S	92781A	92781S
1500	92714A		92748A	92748S	92782A	92782S
1600	92715A		92749A	92749S	92783A	92783S
1700	92716A		92750A	92750S	92784A	92784S
1800	92717A		92751A	92751S	92785A	92785S
1900	92718A		92752A	92752S	92786A	92786S
2000	92719A		92753A	92753S	92787A	92787S
2200	92721A		92755A		92789A	92789S
2400	92723A		92757A		92791A	92791S
2600	92725A		92759A		92793A	92793S
2800	92727A		92761A		92795A	92795S
3000	92729A		92763A		92797A	92797S
3200	92731A		92765A		92799A	92799S
3400	92733A		92767A			

Performance overview

Rated load: stat./dyn. Co/C	N	3400/4200		5400/5400		15100/13500	
Max. moment (MCX/MCY, MCZ)	Nm	81/190		133/338		483/922	
Max. speed	m/s	2	0.25	3	0.25/0.5	5	0.25/0.5/1.25/2.5
Linear travel per motor revolution	mm	60	5	60	5/10	100	5/10/25
Mass: Basic weight/per m stroke/moved	kg	1.8/0.43/0.75	1.9/0.36/0.75	3.7/0.7/1.18	3.6/0.59/1.18	8.2/1.32/2.5	8.8/1.01/2.5
Max. speed per drive module	min⁻¹	2000		3000		3000	
Max. effective thrust force FX < 1 m/s	N	55	250	150	600	425	1500
at speed 1–2 m/s	N	50	250	120	600	375	1500
at speed > 2 m/s	N			100		300	
Basic torque (without load)	Nm	0.4	0.2	0.2	0.2/0.3	0.6	0.3/0.4/0.5
Max. permissible drive torque < 1 m/s	Nm	0.9		2.3	1.5/2.8	10	4.2/7.5/20
at speed 1–2 m/s	Nm	0.9	0.6	2		9.5	
at speed > 2 m/s	Nm			1.8		7.5	
Max. acceleration/delay	m/s²	10	10	10	10	10	10
Repeatability	mm/m	±0.05		±0.05		±0.05	
Positioning accuracy*	mm/m	±0.15		±0.15		±0.15	
Running accuracy	mm	±0.03/300		±0.03/300		±0.03/300	

*Depending on a variety of factors.

Linear modules

Inner guide/toothed belt drive

Type FTD

FTD 15-35

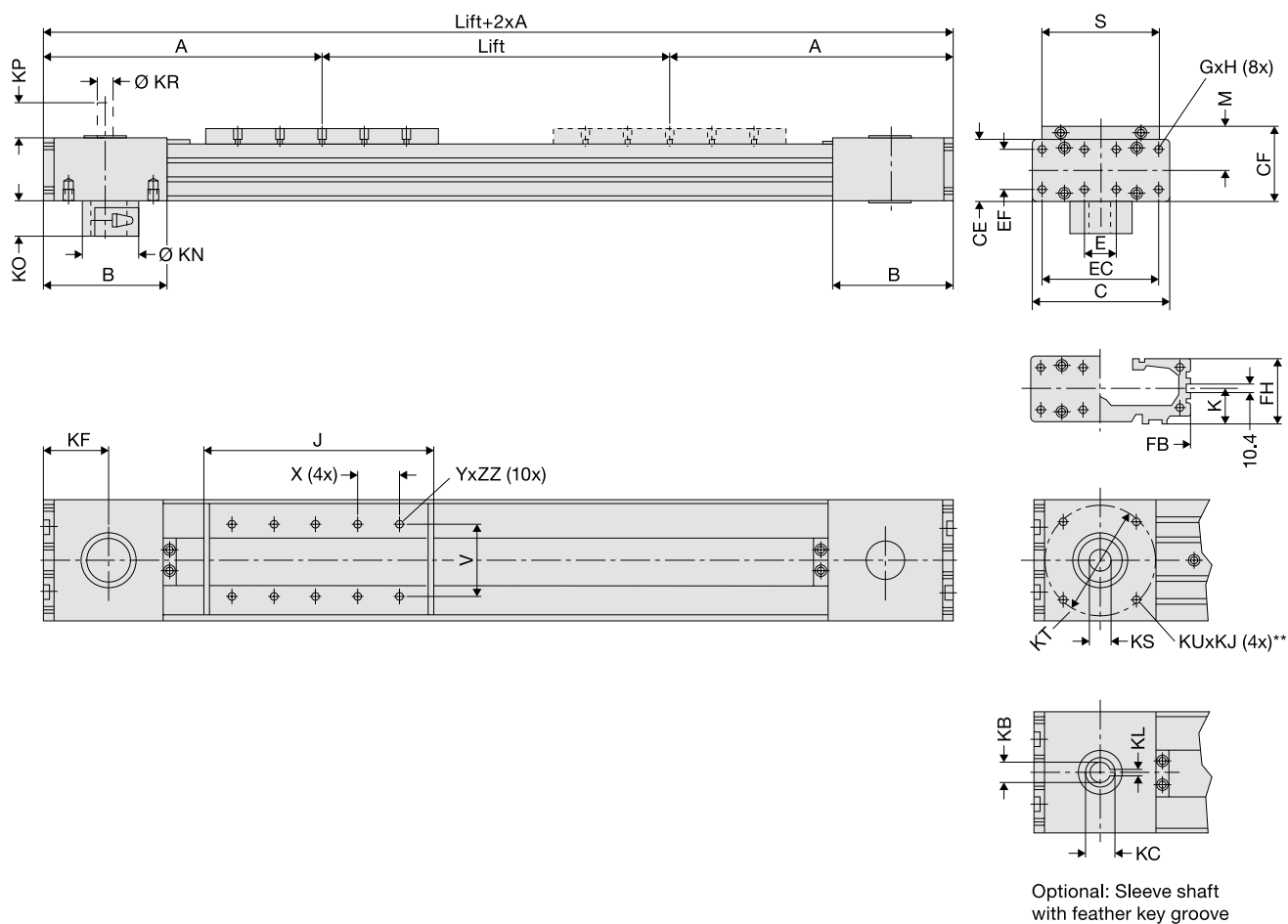

Size	Dimensions mm												
	A	B	C	E	G	H	J	K	M	S	V	X	Y
15	218	88	93	25	M 5	10	178	21.5	31	85	64	40	M 6
20	262	112	116	28	M 6	12	218	28.5	38	100	64	40	M 6
35	347	147	175	18	M 6	12	263	43.0	49	124	90	60	M 6

Size	Dimensions mm																		
	CE	CF	EC	EF	FB	FH	KF	KB*	KC	KL	KJ	KN	KO	KP	KR	KS*	KT	KU	ZZ
15	42	52.5	79	27	92	39.5	49.0	16 ^{H7}	18.3	5	8	34	21.7	30	16 ^{H7}	16 ^{H7}	82	M 8	8
20	56	66.5	100	36	116	51.7	62.0	22 ^{H7}	24.8	6	12	53	30.0	30	22 ^{H7}	22 ^{H7}	106	M 10	10
35	87	92.5	158	70	164	77.0	79.5	32 ^{H7}	35.3	10	19	75	41.0	35	32 ^{H7}	32 ^{H7}	144	M 12	10

Order numbers

Stroke mm	Order no.		
	FTD 15 without motorization	FTD 20 without motorization	FTD 35 without motorization
100	92900A	92925A	92950A
200	92901A	92926A	92951A
300	92902A	92927A	92952A
400	92903A	92928A	92953A
500	92904A	92929A	92954A
600	92905A	92930A	92955A
700	92906A	92931A	92956A
800	92907A	92932A	92957A
900	92908A	92933A	92958A
1000	92909A	92934A	92959A
1200	92910A	92935A	92960A
1400	92911A	92936A	92961A
1600	92912A	92937A	92962A
1800	92913A	92938A	92963A
2000	92914A	92939A	92964A
2500	92915A	92940A	92965A
3000	92916A	92941A	92966A
3500	92917A	92942A	92967A
4000	92918A	92943A	92968A
4500	92919A	92944A	92969A
5000	92920A	92945A	92970A
5500	92921A	92946A	92971A
6000	92922A	92947A	92972A
6500	92923A	92948A	92973A
7000	92924A	92949A	92974A

Performance overview

Rated load: stat./dyn. Co/C	N	3400/4200	5400/5400	18000/12500
Max. moment (MCX/MCY, MCZ)	Nm	45/274	76/460	294/1233
Max. speed	m/s	10	10	10
Max. acceleration/delay	m/s²	40	40	40
Max. effective thrust force FX < 1 m/s	N	1070	1870	3120
at speed 1–3 m/s	N	890	1560	2660
at speed > 3 m/s	N	550	1030	1940
Basic torque (without load)	Nm	1.2	2.2	3.2
Mass: Basic weight/per m stroke/moved	kg	3.8/4.3/1.0	7.7/6.7/1.9	22.6/15.2/4.7
Max. permissible drive torque < 1 m/s	Nm	31	71	174
at speed 1–3 m/s	Nm	25	60	148
at speed > 3 m/s	Nm	16	39	108
Linear travel per motor revolution	mm	180	240	350
Max. speed per drive module	min⁻¹	3000	2500	1700
Repeatability	mm/m	+/-0.05	+/-0.05	+/-0.05
Positioning accuracy*	mm/m	+/-0.15	+/-0.15	+/-0.15
Running accuracy	mm	+/-0.03/300	+/-0.03/300	+/-0.03/300

*Depending on a variety of factors.



Linear modules

Inner guide/toothed belt drive

Type FTI

FTI20

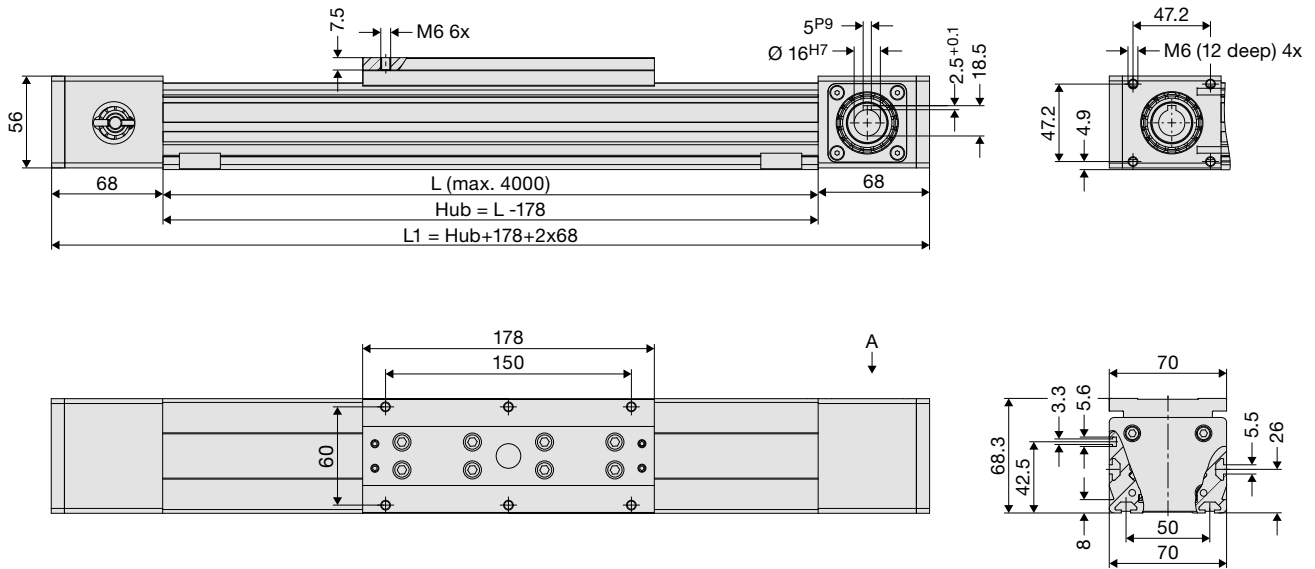

Stroke mm	Load rating N		Moments Nm				Dimensions mm		
	C	C ₀	M _{cx}	M _{cy,cz}	M _{ox}	M _{Oy,0z}	L1	LS	DD
100	8100	8100	116	238	116	238	414	178	150
200	8100	8100	116	238	116	238	514	178	150
300	8100	8100	116	238	116	238	614	178	150
400	8100	8100	116	238	116	238	714	178	150
500	8100	8100	116	238	116	238	814	178	150
600	8100	8100	116	238	116	238	914	178	150
700	8100	8100	116	238	116	238	1014	178	150
800	8100	8100	116	238	116	238	1114	178	150
900	8100	8100	116	238	116	238	1214	178	150
1000	8100	8100	116	238	116	238	1314	178	150
1500	8100	8100	116	238	116	238	1814	178	150
2000	8100	8100	116	238	116	238	2314	178	150
2500	8100	8100	116	238	116	238	2814	178	150
3000	8100	8100	116	238	116	238	3314	178	150
3500	8100	8100	116	238	116	238	3814	178	150
4000	8100	8100	116	238	116	238	4314	178	150

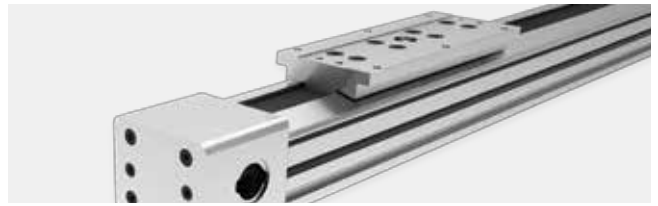

The new linear module type FTI enhances the product program with an integrated toothed belt drive. The raceway and roller shoes are fitted compactly and protected on the inside of the module body.

The module is motorized by a robust toothed belt that simultaneously closes the aluminium U profile and protects the guide system from dirt penetrating.

The function of the guide rail is based on roller technology, also used in the long-standing Franke Dynamic type linear guides: Arranged crosswise, rollers with needle bearings absorb the load and provide persuasive absorption in their rapid response behaviour during dynamic movements.

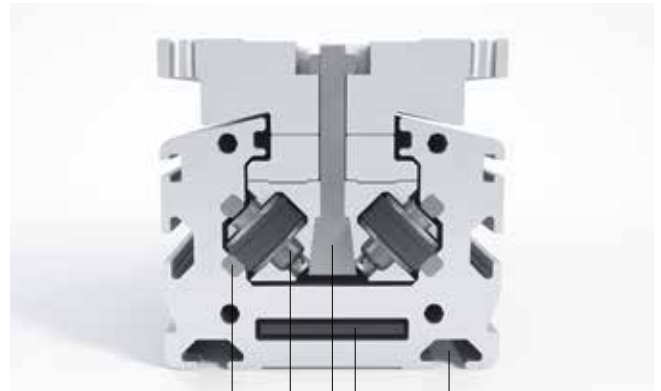

Inner rail system insensitive to dirt

Drawn aluminium profile with mounting channels for groove keys

Rollers arranged crosswise for load from all directions

Return channel on the toothed belt protected in the housing profile

Adjustable slide resistance depending on the load

Performance overview

Rated load: stat./dyn. C_v/C	N	8100/8100
Max. moment ($M_{cx}/M_{cy,cz}$)	Nm	116/238
Max. speed	m/s	10
Max. acceleration/delay	m/s²	40
Max. effective thrust force F_x	N	1000
Basic torque (without load)	Nm	0.4
Mass: Basic weight/per meter stroke/moved	kg	1.1/5.1/1.1
Max. permissible drive torque	Nm	19.5
Linear travel per motor revolution	mm	122
Max. speed per drive module	min⁻¹	5000
Repeatability	mm/m	+/-0.05
Positioning accuracy	mm/m	+/-0.15
Running accuracy	mm	+/-0.03/300



Linear modules

Outer rail/linear motor drive

Type FTH

FTH25A/FTH25B

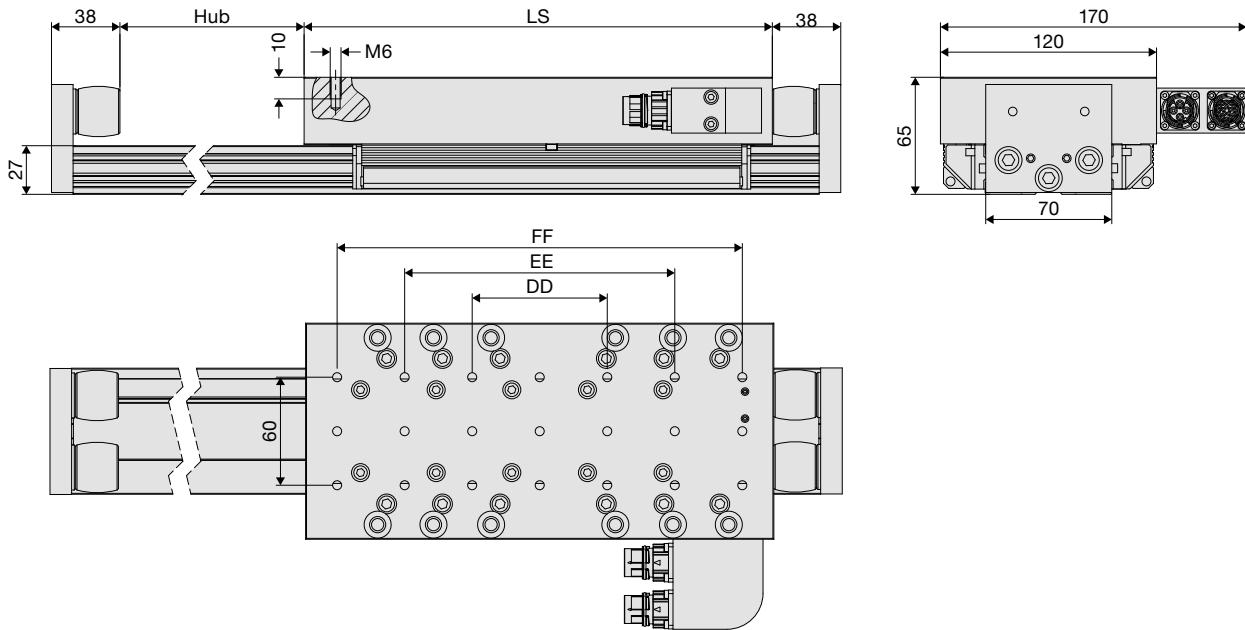

Performance overview/designs

		FTH25A	FTH25B	Optional
Max. speed	m/s	6	6	
Max. acceleration	m/s ²	100	100	
Max. travel	mm	3625	3530	Longer travel on request
Weight of rail	kg/m	17.5	17.5	
Weight of slide	kg	3	5	Second slide
Thrust force duration	N	61	115	
Thrust force peak	N	162	323	
Positioning accuracy*	mm/m	0.02	0.02	
Running accuracy	mm/m	0.04	0.04	
Repeatability (discrimination)	mm	0.02	0.02	
Input voltage U_{dc}	V	310	310	
Permanent current I_{nc}	A	2.1	2.1	
Peak current I_{peak}	A	6	6	
Winding resistance R_{u-v}		3.8	7.6	
Winding inductance L_{u-v}	mH	20.4	40.7	
Pole pair width	mm	24	24	
Temperature gage	KTY81 (2000 Ohm/25 °C)			
Measurement system	1 Vpp (discrimination 1 µm, separation 1 mm)			
End switch	-			2 final locations/1 reference (PNP-Ö, PNP-S)
Brake	-			Pneumatic
Cover	-			Bellows
Cable tow	-			Plastic/metal

Special designs on request (e.g. water cooling, longer carriage for higher loads, 2nd slide, etc.).

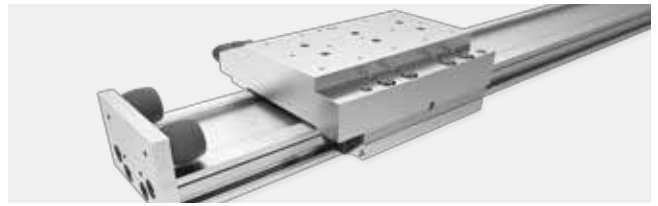

Order numbers

Stroke	Load rating N		Moments Nm					Dimensions mm					Order no.
	C	C ₀	M _{cx}	M _{cy}	M _{cz}	M _{ox}	M _{oy, Moz}	L1	LS	DD	EE	FF	
265	7500	3700	293	165	145	82	506	165	75	150	-	93220A	
505	7500	3700	293	165	145	82	746	165	75	150	-	93221A	
745	7500	3700	293	165	145	82	986	165	75	150	-	93222A	
985	7500	3700	293	165	145	82	1226	165	75	150	-	93223A	
1225	7500	3700	293	165	145	82	1466	165	75	150	-	93224A	
1465	7500	3700	293	165	145	82	1706	165	75	150	-	93225A	
1705	7500	3700	293	165	145	82	1946	165	75	150	-	93226A	
1945	7500	3700	293	165	145	82	2186	165	75	150	-	93227A	
2185	7500	3700	293	165	145	82	2426	165	75	150	-	93228A	
2425	7500	3700	293	165	145	82	2666	165	75	150	-	93229A	
2665	7500	3700	293	165	145	82	2906	165	75	150	-	93230A	
2905	7500	3700	293	165	145	82	3146	165	75	150	-	93231A	
3145	7500	3700	293	165	145	82	3386	165	75	150	-	93232A	
3385	7500	3700	293	165	145	82	3626	165	75	150	-	93233A	
3625	7500	3700	293	165	145	82	3866	165	75	150	-	93234A	

FTH25B

170	15000	7400	293	461	145	228	506	260	75	150	225	93235A
410	15000	7400	293	461	145	228	746	260	75	150	225	93236A
650	15000	7400	293	461	145	228	986	260	75	150	225	93237A
890	15000	7400	293	461	145	228	1226	260	75	150	225	93238A
1130	15000	7400	293	461	145	228	1466	260	75	150	225	93239A
1370	15000	7400	293	461	145	228	1706	260	75	150	225	93240A
1610	15000	7400	293	461	145	228	1946	260	75	150	225	93241A
1850	15000	7400	293	461	145	228	2186	260	75	150	225	93242A
2090	15000	7400	293	461	145	228	2426	260	75	150	225	93243A
2330	15000	7400	293	461	145	228	2666	260	75	150	225	93244A
2570	15000	7400	293	461	145	228	2906	260	75	150	225	93245A
2810	15000	7400	293	461	145	228	3146	260	75	150	225	93246A
3050	15000	7400	293	461	145	228	3386	260	75	150	225	93247A
3290	15000	7400	293	461	145	228	3626	260	75	150	225	93248A
3530	15000	7400	293	461	145	228	3866	260	75	150	225	93249A



Linear modules

Linear module with linear motor operation

Type FTH

FTH35A/FTH35B

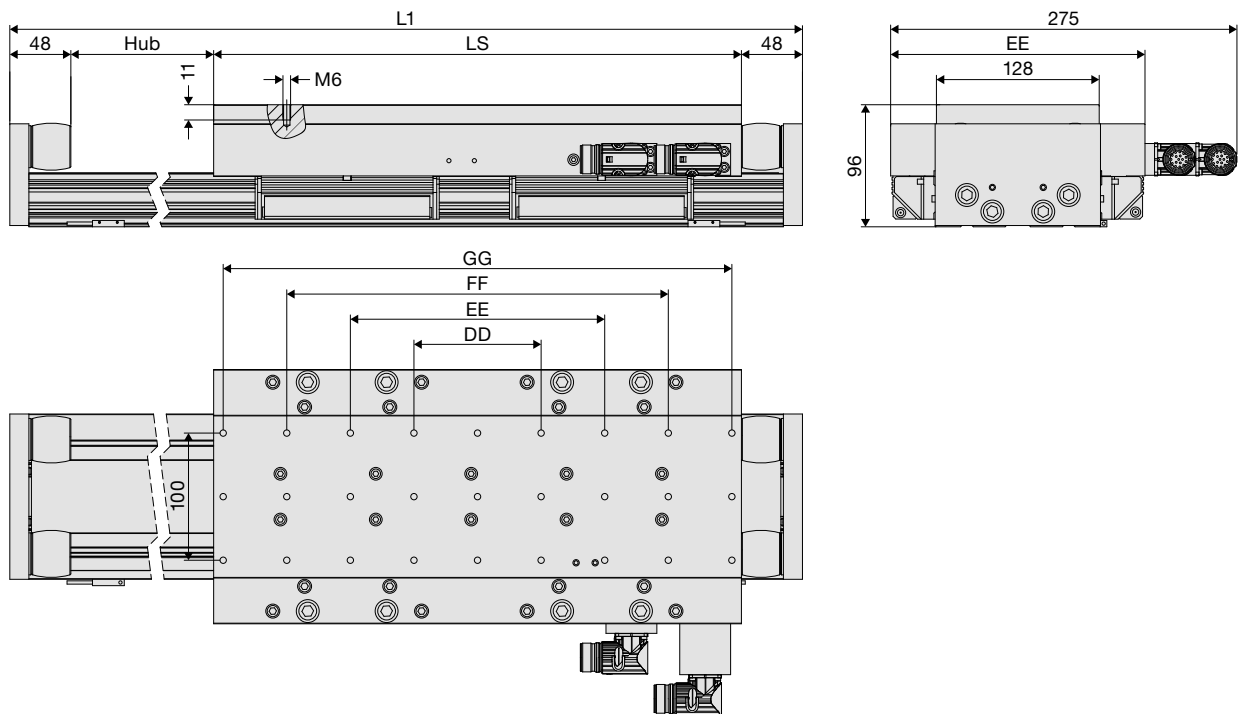

Performance overview/designs

		FTH25A	FTH25B	Optional
Max. speed	m/s	6	6	
Max. acceleration	m/s²	100	100	
Max. travel	mm	3536	3361	Longer travel on request
Weight of rail	kg/m	17.5	17.5	
Weight of slide	kg	9	16	Second slide
Thrust force duration	N	280	560	
Thrust force peak	N	650	1300	
Positioning accuracy*	mm/m	0.02	0.02	
Running accuracy	mm/m	0.04	0.04	
Repeatability (discrimination)	mm	0.02	0.02	
Input voltage U_{dc}	V	560	560	
Permanent current I_{nc}	A	2.8	5.7	
Peak current I_{peak}	A	8.0	16.0	
Winding resistance R_{u-v}	Ω	7.4	3.7	
Winding inductance L_{u-v}	mH	55	27	
Pole pair width	mm	32	32	
Temperature gage	KTY81 (2000 Ohm/25 °C)			
Measurement system	1 Vpp (discrimination 1 μ m, separation 1 mm)		Absolute measurement system	
End switch	-		2 final locations/1 reference (PNP-Ö, PNP-S)	
Brake	-		Pneumatic	
Cover	-		Bellows	
Cable tow	-		Plastic/metal	

Special designs on request (e.g. water cooling, longer carriage for higher loads, 2nd slide, etc.).

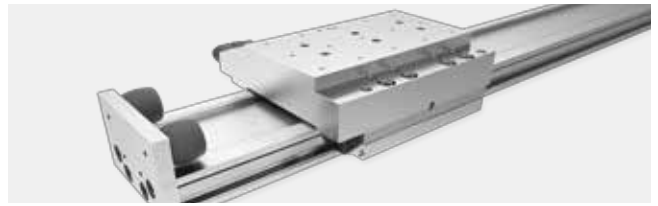

Order numbers

Stroke	Load rating N		Moments Nm					Dimensions mm					Order no.
	C	C _o	M _{cx}	M _{cy}	M _{cz}	M _{ox}	M _{oy, Moz}	L1	LS	DD	EE	FF	
208	29900	34500	1100	1000	1250	1150	544	240	100	200	-	-	92870A
464	29900	34500	1100	1000	1250	1150	800	240	100	200	-	-	92871A
720	29900	34500	1100	1000	1250	1150	1056	240	100	200	-	-	92872A
976	29900	34500	1100	1000	1250	1150	1312	240	100	200	-	-	92873A
1232	29900	34500	1100	1000	1250	1150	1568	240	100	200	-	-	92874A
1488	29900	34500	1100	1000	1250	1150	1824	240	100	200	-	-	92875A
1744	29900	34500	1100	1000	1250	1150	2080	240	100	200	-	-	92876A
2000	29900	34500	1100	1000	1250	1150	2336	240	100	200	-	-	92877A
2256	29900	34500	1100	1000	1250	1150	2592	240	100	200	-	-	92878A
2512	29900	34500	1100	1000	1250	1150	2848	240	100	200	-	-	92879A
2768	29900	34500	1100	1000	1250	1150	3104	240	100	200	-	-	92880A
3024	29900	34500	1100	1000	1250	1150	3360	240	100	200	-	-	92881A
3280	29900	34500	1100	1000	1250	1150	3616	240	100	200	-	-	92882A
3536	29900	34500	1100	1000	1250	1150	3872	240	100	200	-	-	92883A
3625	7500	3700	293	165	145	82	3866	165	75	150	-	-	93234A

FTH35B

289	29900	34500	2150	3000	2500	3450	800	415	100	200	300	400	92884A
545	29900	34500	2150	3000	2500	3450	1056	415	100	200	300	400	92885A
801	29900	34500	2150	3000	2500	3450	1312	415	100	200	300	400	92886A
1057	29900	34500	2150	3000	2500	3450	1568	415	100	200	300	400	92887A
1313	29900	34500	2150	3000	2500	3450	1824	415	100	200	300	400	92888A
1569	29900	34500	2150	3000	2500	3450	2080	415	100	200	300	400	92889A
1825	29900	34500	2150	3000	2500	3450	2336	415	100	200	300	400	92890A
2081	29900	34500	2150	3000	2500	3450	2592	415	100	200	300	400	92891A
2337	29900	34500	2150	3000	2500	3450	2848	415	100	200	300	400	92892A
2593	29900	34500	2150	3000	2500	3450	3104	415	100	200	300	400	92893A
2849	29900	34500	2150	3000	2500	3450	3360	415	100	200	300	400	92894A
3105	29900	34500	2150	3000	2500	3450	3616	415	100	200	300	400	92895A
3361	29900	34500	2150	3000	2500	3450	3872	415	100	200	300	400	92896A
3290	15000	7400	293	461	145	228	3626	260	75	150	225	-	93248A
3530	15000	7400	293	461	145	228	3866	260	75	150	225	-	93249A

FTH35B is optionally available in heavy duty design with double load rating.



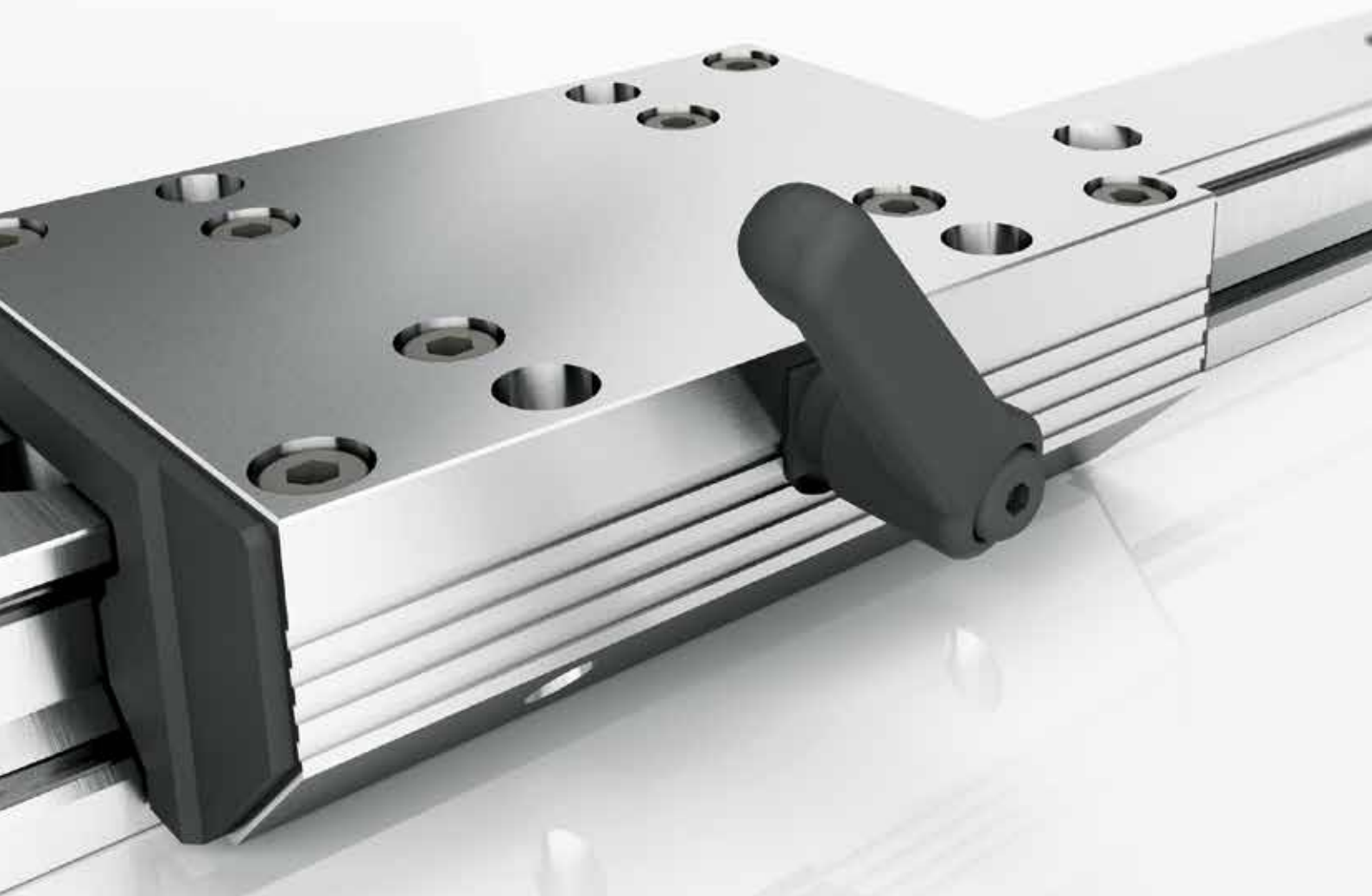

Accessories

Linear Systems

Product	Page
Franke Dynamic	118–119
Cassette with clamp	118
Metal wiper for cassettes	118
Bellows	119
Stop screws	119
Caps for rail bores	119
Linear tables/linear modules	120–121
Mounting	120
Intermediate drive shaft for multi-rail arrangement	121
Limit switch	121

Accessories

Franke Dynamic

Clamping

Cassette with star grip or clamp lever to attach to any position on the rail guide. The clamping does not exert force on the rail system. It is used for appliances that can be operated

manually, clamping and holding stops, provision of tools and processing components. We are pleased to advise you.

with star grip

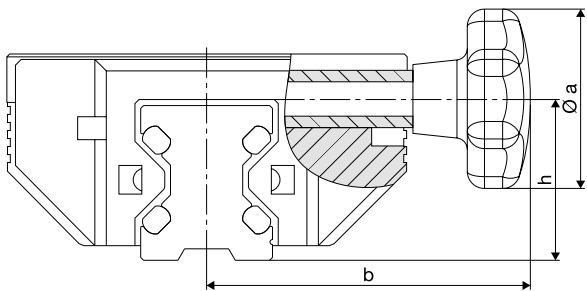

Size	Dimensions				Order no.	
	mm Ø a	b	h	N Holding force	Standard	Non-corrosive
15	25	41	19.0	200	84396AK	84396NK
20	25	49	23.0	250	84441AK	84441NK
25	32	56	28.0	250	84363AK	84363NK
35	50	83	38.5	350	84364AK	84364NK
45	63	101	48.0	750	84365AK	84365NK

with clamp lever

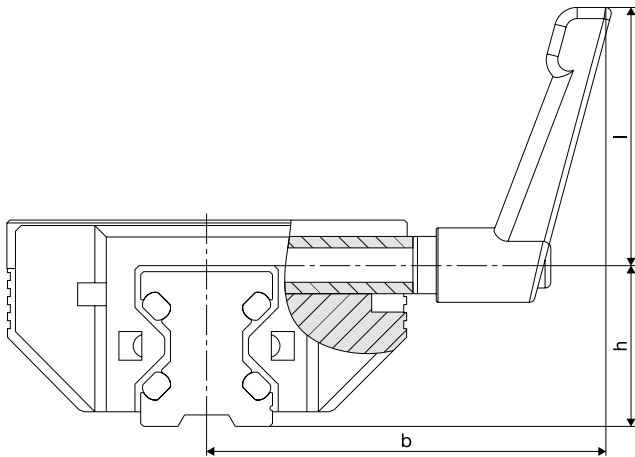

Size	Dimensions					Order no.	
	l	Weight	b	h	N Holding force	Standard	Non-corrosive
15	45	M 5	59.5	64.0	200	84396AH	84396NH
20	45	M 5	67.5	68.0	250	84441AH	84441NH
25	45	M 6	71.0	73.0	250	84363AH	84363NH
35	63	M 8	96.0	101.5	350	84364AH	84364NH
45	78	M 10	116.0	126.0	750	84365AH	84365NH

Metal wiper

The metal wipers are placed in the wiper plate along with the felt wipers and clipped on there. They are used to remove

coarse dirt such as metal shavings, welding spatter and wood dust.

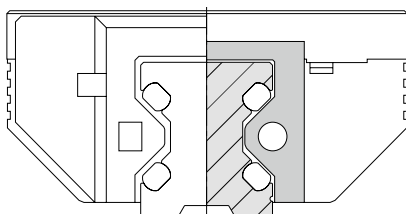

Size	Order no.
12	69126A
15	69127A
20	69128A
25	69129A
35	69130A
45	69131A

Bellows

The bellows for aluminium roller guides protect the rail system against coarse dirt. They are available in any lengths. The applied Velcro patches are used for attaching to the cassette and end plate. The cassette wipers are no longer needed.

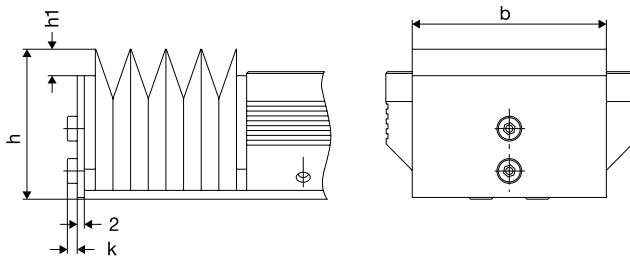

Material: synthetic fabric with one-sided polyurethane coating; temperature: contact heat +80 °C, radiant heat +120 °C.

Size	Dimensions mm				Order no.
	b	h	h1	k	
15	42	31.0	7.0	2.8	on request
20	47	35.0	5.0	2.8	
25	55	42.5	6.5	2.8	
35	68	55.0	7.0	3.5	
45	87	67.0	7.0	3.5	

Stop screws

The stop screws are screwed into the thread (option) on the guide rails. A fitted rubber cap dampens impact. We deliver the drilling template displaced by one half bore gap for rail

lengths with initial drilling dimensions below L11 min.
Material: Chlorbutadiene rubber (C₂), black.

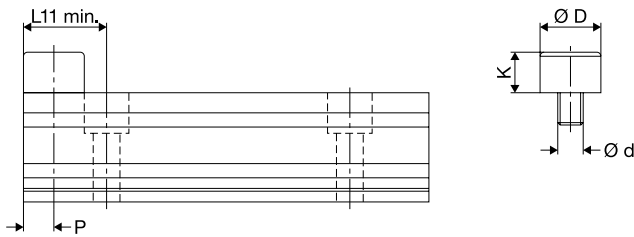

Size	Dimensions mm					Order no.
	d	D	K	L11 min.	P	
12	M 5	12	8	15.0	6.0	63504A
15	M 5	12	8	16.0	6.0	63504A
20	M 5	12	8	17.0	6.0	63504A
25	M 6	15	10	20.5	7.5	63505A
35	M 8	19	13	26.5	9.5	63506A
45	M 10	24	16	33.0	12.0	63507A

Caps

In order to ensure that the wipers function ideally, the bores on the guide rails should be sealed using plastic caps enclosed

with the delivery. You can order replacements individually.
Material: POM wear-proof plastic, resistant to oil and ageing.

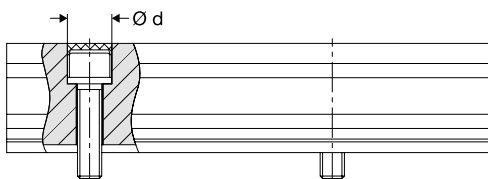

Size	Dimensions mm		Order no.
	Cylinder screw DIN912	D	
12	M 3	6	87752A
15	M 4	8	87753A
20	M 5	10	87754A
25	M 6	11	87755A
35	M 8	15	87756A
45	M 10	18	87757A

Accessories

Linear tables/linear modules

Linear module type FTC/FTD

Sectional fastener

MAE

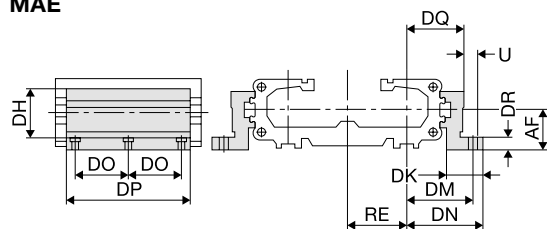

T-assembly rail

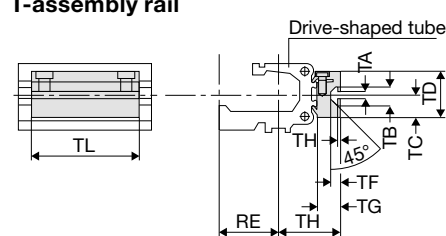

Size	Dimensions mm																			Order no.
MAE	R	U	AF	DF	DH	DK	DM	DN	DO	DP	DQ	DR	DT	EF	EM	EN	EQ	RE		
15	M 5	5.5	22	27	38	26	40	47.5	40	92	34.5	8	10	41.5	28.5	49	36	26	92981A	
20	M 5	5.5	30	33	46	27	46	54.5	40	92	40.5	10	10	48.5	35.5	57	43	32	92982A	
25/35	M 6	7.0	48	40	71	34	59	67.0	45	112	52.0	10	11	64.0	45.0	72	57	44	92983A	

Size	Dimensions mm											Order no.
T	RE	TA	TB	TC	TD	TE	TF	TG	TH	TL		
15	26	5.0	11.5	16	32	1.8	6.4	14.5	34.5	50	92835A	
20	32	5.0	11.5	16	32	1.8	6.4	14.5	40.5	50	92836A	
25/35	44	8.2	20.0	20	43	4.5	12.3	20.0	58.0	80	92837A	

E1

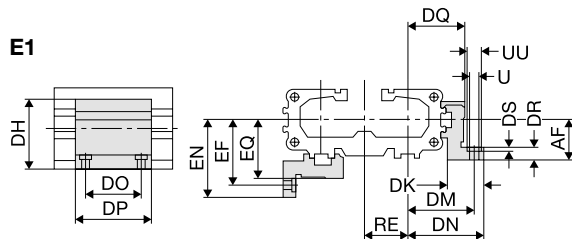

D1

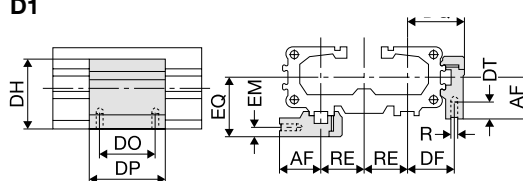

Size	Dimensions mm																			Order no.
R	U	UU	AF	DF	DH	DK	DM	DN	DO	DP	DQ	DR	DS	DT	EF	EM	EN	EQ	RE	

E1	15	M 5	5.5	10	22	27	38	26	40	47.5	36	50	34.5	8	5.7	10	41.5	28.5	49	36	26	92821A
	20	M 5	5.5	10	30	33	46	27	46	54.5	36	50	40.5	10	5.7	10	48.5	35.5	57	43	32	92826A
	25/35	M 6	7.0	-	48	40	71	34	59	67.0	45	60	52.0	10	-	11	64.0	45.0	72	57	44	92831A

D1	15	M 5	5.5	10	22	27	38	26	40	47.5	36	50	34.5	8	5.7	10	41.5	28.5	49	36	26	92820A
	20	M 5	5.5	10	30	33	46	27	46	54.5	36	50	40.5	10	5.7	10	48.5	35.5	57	43	32	92825A
	25/35	M 6	7.0	-	48	40	71	34	59	67.0	45	60	52.0	10	-	11	64.0	45.0	72	57	44	92830A

Lid fastener

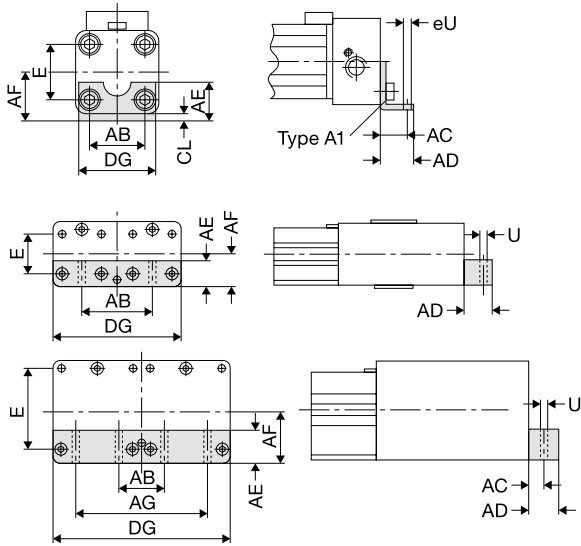

Size	Dimensions mm								Order no.
A1	E	Ø U	DIS	AC	AD	AE	AF	DG	
15	27	5.8	27	16	22	18	22	39	92810A
20	36	6.6	36	18	26	20	30	50	92813A

Size	Dimensions mm								Order no.	
C1	E	Ø U	DIS	AC	AD	AE	AF	AG	DG	
15	27	6.6	52	16.0	25	25	22	-	91	92978A
20	36	9.0	64	18.0	25	25	30	-	114	92979A
25/35	70	9.0	48	12.5	30	30	48	128	174	92980A

Intermediate drive shaft

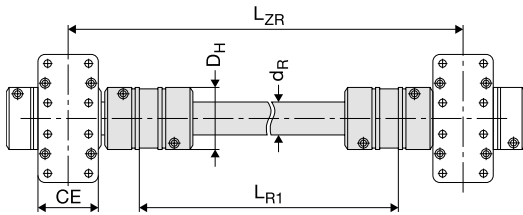

Size	Max. torque Nm	Dimensions mm						Order no.
		DH	Kb _{max}	LD	L _{r1}	L _{ZR}	d _R	
15	60	55	16 _{h7}	5	<3000	L _{r1} +112	30x4.0	92997A
20	60	55	22 _{h7}	5	<3000	L _{r1} +126	30x4.0	92998A
35	160	65	32 _{h7}	5	<3000	L _{r1} +167	35x4.0	92999A

End switch

RS	RS	ES	ES
Order no.			
Reed normally open contact	Reed normally closed contact	PNP normally open contact	PNP normally closed contact
Type:	Type:	Type:	Type:
RS-K	RS-K	ES-S	ES-S
92841A	92842A	92844A	92845A
RS-S	RS-S		
92847A	92843A		

Connection cable 5 m with cable coupling and open end
For signal transmitter type ES-S/RS-S

[92846A](#)

Technical Information

Linear Systems

Table of contents	Page
1 Type FD – Franke Dynamic	124–128
1.1 Designs and system descriptions	
1.2 Design of the guides	
1.3 Calculation of Linear Systems	
1.3.1 Terms, dimensions	
1.3.2 Static calculation	
1.3.3 Dynamic calculation	
1.3.4 Calculation example	
1.3.4.1 Static safety	
1.3.4.2 Service life	
1.4 Instructions for the connecting construction	
1.4.1 Connecting plate for type FD	
1.4.2 Multi-rail arrangements	
1.4.3 Assembly space	
1.4.4 Attaching the rails	
1.4.5 Assembly instructions for coupled rails	
1.4.6 Slide resistances	
1.4.7 Running accuracy and rigidity	
2 Linear tables/modules	128–129
2.1 Design	
2.2 Area of use	
2.3 Limit switch and reference switch	
2.4 Maintenance and lubrication	
2.5 Definition	
3 Type FTH	129–131
3.1 Design	
3.2 Area of use	
3.3 Accuracy	
3.4 Dynamism	
3.5 Motorization	
3.6 Control	
3.7 Measurement system and limit, i.e. reference switch	
3.8 Multiple module units	

Technical Information

Linear Systems

Franke aluminium Linear Systems have base bodies made of high-strength anodized aluminium. Depending on their type, the rollers are mounted on needle or ball bearings and are made of roller bearing steel. Face plates made of plastic house the felt wipers that keep the guide system clean.

1 Type FD – Franke Dynamic

1.1 Designs and system description

Aluminium roller guides by Franke are available as double rails with cassette or as a pair of single rails with a pair of roller shoes:

Double rail with cassette

By standard, the design with double rail and cassette is a fully calibrated linear guide. The cassette and rail come with standard market connection bores.

Pair of single rails with pair of roller shoes (Diagram 1)

The single rails with roller shoes are integral elements of the design, offering the benefit of variable guide width. The customer specifies the connecting plate.

The cassette or the pair of roller shoes in standard type

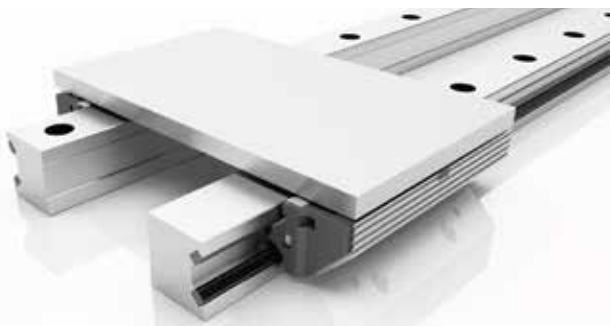

Diagram 1: Pair of single rails and pair of roller shoes

FDA each run over four rollers mounted on needle bearings and arranged crosswise, fitted on raceways made of tough-but-flexible spring steel. Other types are available for special applications, among them non-corrosive raceways or individual customized versions.

The aluminium roller guides are lifetime lubricated. Travel speeds of 10 m/s and acceleration of 40 m/s² can be achieved. The operating temperature of the guides is between -20 °C and +100 °C. Franke is pleased to provide advice if you require solutions suitable for temperatures outside of the range specified above.

Cassettes are mounted on rails and factory set free from clearance. An integrated clearance adjuster can be used downstream to align the aluminium roller guides to their respective load situation. The clearance setting is best determined by measuring the slide resistance in an unloaded state (see Diagram 2).



Diagram 2: Measure slide resistance

The screw connection on the cassette plate is loosened slightly to make the setting. After this the threaded pin integrated in the longer cassette side is reset. Turning the threaded pin displaces the roller shoe and hence increases or reduces preload.

The setting values for the individual type are listed in Table 3.6 Slide resistances. Please find more precise instructions on fitting and setting the guides in the assembly instructions for the aluminium roller guides.

1.2 Design of the guides

The following parameters are required to correctly design the guides:

- Selection of arrangement
- All prevalent forces/moments (dynamic/static), (see Diagram 3)
- Load type (resting, expanding, alternating)
- Ambient influences (e.g. temperature, moisture) or special operating conditions (e.g. clean room, vacuum)
- Travel speed and acceleration
- Stroke length
- Target service life in km

All prevailing forces and moments must be within the specified limits. The relevant data are found on the type pages.

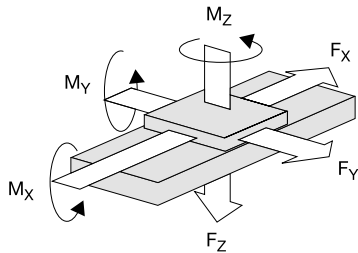
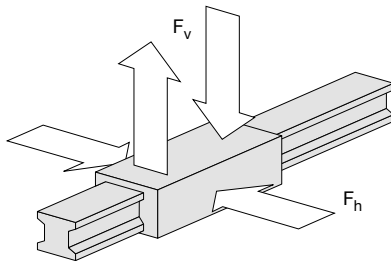

Diagram 3: Arrangement of forces and moments

Recommended safeties (given Screw quality 8.8):

- Pressure load: $S > 1.2$
- Tensile load: $S > 2.5$
- Moment load: $S > 4.0$

1.3 Calculation of Linear Systems



1.3.1 Terms, dimensions

C	= dynamic rated load	(N)
C_0	= static rated load	(N)
D_a	= diameter of rollers	(mm)
F	= dynamic equivalent load	(N)
F_a	= off-center load	(N)
F_0	= static equivalent load	(N)
F_1, F_2, F_n	= individual loads	(N)
F_h, F_v	= horizontal force/vertical force	(N)
L	= service life	(km)
$M_{0cx, 0cy, 0cz}$	= per. stat. moment rated load	(Nm)
$M_{cx, cy, cz}$	= per. stat. or dyn. torsion moment	(Nm)
q_1, q_2	= time quotient for F1, F2	(%)
S	= safety	

1.3.2 Static calculation

A static calculation is sufficient with load at rest or in minimal linear motion up to $v \leq 0.1\text{m/s}$. A linear guide with sufficient load capacity would be chosen once the recommended static safety S is reached.

Static safety

$$S = \frac{C_0}{F_0}$$

The equivalent load is the product of adding the individual external loads F_v and F_h .

$$\text{Stat. equivalent load} \quad F_0 = F_v + F_h$$

An off-center load F_a with a torsion moment M_0 produces the following correlation:

$$F_0 = F_0 + C_0 \cdot \frac{M_x}{M_{0cx}} + C_0 \cdot \frac{M_{yz}}{M_{0cy,0cz}}$$

1.3.2.1 Recommended safeties

Condition	Recommended safety
	Screw qual. 8.8
Pressure load	$S > 1.3$
Tensile load	$S > 2.5$
Moment load	$S > 4.0$

1.3.3 Dynamic calculation

We recommend a dynamic calculation of the load circumstances if there is linear movement with $v > 0.1\text{ m/s}$.

$$\text{Service life} \quad L = \left(\frac{C}{F}\right)^P \cdot \Pi \cdot D_a$$

(with $P = 10/3$ for the types FDA, FDC, FDD and FDE, and $P = 3$ for the types FDB, FDG, FDH)

The calculation is based on the following roller diameters D_a :

Size	Diameter of rollers D_a (mm)
12	11.0
15	12.5
20	15.5
25	19.0
35	27.5
45	34.5

The equivalent load is the product of adding the individual external loads F_v and F_h .

$$\text{Dyn. equivalent load} \quad F = F_v + F_h$$

An off-center load F_a with a torsion moment M produces the following correlation:

$$F = F_a + C \cdot \frac{M}{M_{dyn.}}$$

Technical Information

Linear Systems

These calculations are based on a single one-rail arrangement of linear guides. We would be pleased to perform the calculation for you when dealing with multi-rail arrangements or complicated load circumstances.

1.3.4 Calculation example

For your application you determined the load values F_v and F_h and would like to know whether an aluminium roller guide Franke Dynamic type FDA in size 25 will provide sufficient safety and service life.

Your values (examples):

$$\begin{aligned} F_v &= 2000 \text{ N} \\ F_h &= 400 \text{ N} \\ F &= F_v + F_h = 2400 \text{ N} \end{aligned}$$

Franke Dynamic FDA size 25:

$$\begin{aligned} C &= 9000 \text{ N} \\ C_0 &= 10100 \text{ N} \\ D_a &= 19 \text{ mm} \end{aligned}$$

1.3.4.1 Static safety

In your application there will be an overhead load. Please find a recommended safety of > 2.5 in Table 2.1.

$$S = \frac{C_0}{F_0} = \frac{10100 \text{ N}}{2400 \text{ N}} = 4.2$$

The calculation confirms adequate safety.

1.3.4.2 Service life

$$L = \left(\frac{C}{F} \right)^p \cdot \Pi \cdot D_a = \left(\frac{9000}{2400} \right)^{10} \cdot 3,14 \cdot 19 = 4890$$

The service life is 4890 kilometers.

1.4 Instructions for the connecting construction

1.4.1 Connecting plate for type FD

When using single rails and roller shoes please also use a connecting plate (additional design). The roller shoes and the connecting plate form the runner.

Instruction on designing the connecting plate for the runner: The roller shoes come with centering grooves to facilitate adjustment during assembly. To do this you attach a centering web to the connecting plate (Diagram 4). The dimensions for producing the centering web are listed in Table 1. All other dimensions, tolerances and accuracies of the guides are listed on the respective pages.

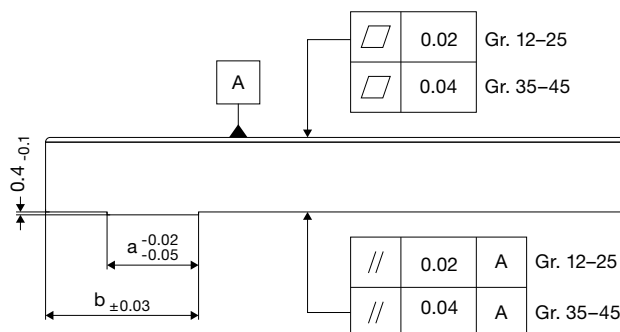

Diagram 4: Centering web

Size	a mm	b mm
12	4.5	9.6
15	5.0	12.6
20	7.5	16.1
25	10.5	17.6
35	12.5	26.1
45	15.5	31.1

Table 1: Dimensions of centering web

1.4.2 Multi-rail arrangements

If there is a multi-rail arrangement it is recommended to define a fixed and a loose bearing side on the runner plate. This is the best method to compensate tolerances between the rails.

For instance the loose bearing side can be designed with a catch and a stay rod. The fixed bearing side assumes the guide function, while the loose bearing side compensates parallel adjustment and height tolerances. It is recommended to design the drive in the immediate proximity of the guide side, as it is what absorbs the drive moments.

1.4.3 Assembly space

The input and connecting surfaces have substantial influence on the function and accuracy of the guide. Inaccuracies may accumulate on top of the running accuracy of the guide system. An exact parallel and height adjustment is necessary if there is a double-track arrangement, for instance. The accuracy of the screw-on and connection surfaces for the rails as specified in Table 2 must be adhered to in order to guarantee running accuracy of the guide:

Size	12-20 mm	25-45 mm
Max. tolerance for parallel run	0.03/m	0.05/m
Max. evenness of screw-on surface	0.05/m	0.10/m

Table 2: Accuracy of input and connecting surfaces

1.4.4 Attaching the rails

Use a ruler or a locating shoulder to align of the rails. Depending on the type of load, the guide rails should be

1. screwed on or
2. screwed on and dowelled or
3. applied against a locating shoulder and screwed on (Table 5).

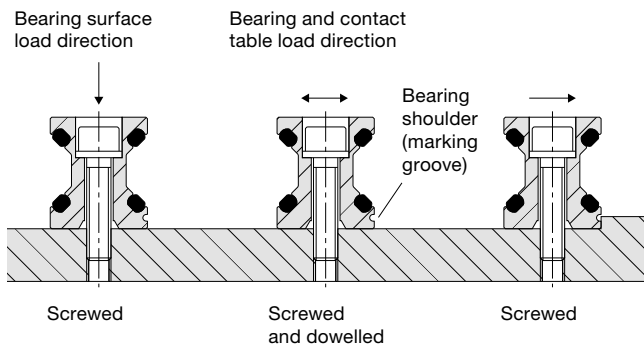

Diagram 5: Attaching the rails

The connections between the guide elements and the connecting construction influence the load capacity of the guide. Screws in quality 8.8 with washers DIN 433 are used to make the attachment to the connecting construction.

1.4.5 Assembly instruction for coupled rails

Rails above a length of 4000 mm are coupled according to the Franke standard. Separation according to the Franke standard guarantees a constant, even drilling pattern and an ideal use of the rail length. Separations according to customer specifications are also possible.

Coupled rails are specifically matched.

This is why the rails have a sequential product number (e.g. A/1-1/1-2/2-2/E) to ensure correct assembly.



Diagram 6: Coupled rails/auxiliary cylinder

The rails are labelled additionally with a marking groove below the lower edge of the rail; it must always be on the same side. The rails must be aligned without a gap. To do this please use the suitable auxiliary cylinder (Diagram 6). Dimensions for aligning the auxiliary cylinder are found in Table 3. The cylinders are inserted into the raceways at the separating point of the rails and loaded using a suitable device. The matching tightening torques for the screw connections in question are listed in Table 4.

Size	Auxiliary cylinder mm
12	11
15	11
20	14
25	16
35	27
45	35

Table 3: Dimensions of auxiliary cylinder

Screw	Tightening torque
M 3	1.1
M 4	2.5
M 5	5.0
M 6	8.5
M 8	21.0
M 10	41.0
M 12	71.0

Table 4: Tightening torques for screw connections

1.4.6 Slide resistances*

Size	Slide resistance N							
	FDA	FDB	FDG	FDC	FDD	FDE	FDH	
12	Min.	1.0	0.15	0.2	1.0	-	0.5	-
	Max.	1.5	0.30	0.3	2.0	-	2.0	-
15	Min.	0.5	0.20	0.2	0.5	-	0.8	-
	Max.	2.0	0.40	0.3	2.0	-	2.0	-
20	Min.	1.5	0.50	0.5	1.5	-	1.0	-
	Max.	2.5	0.90	0.9	2.5	-	2.5	-
25	Min.	1.5	0.40	1.0	1.5	1.5	1.5	2.5
	Max.	3.0	0.80	1.5	3.0	3.0	3.0	5.0
35	Min.	2.0	1.00	3.0	2.0	-	2.0	4.0
	Max.	4.0	1.50	4.0	4.0	-	4.0	6.0
45	Min.	5.0	2.00	3.0	5.0	-	5.0	5.0
	Max.	8.0	3.00	4.0	8.0	-	8.0	8.0

* Without wipers

Technical Information

Linear Systems

1.4.7 Running accuracy and rigidity

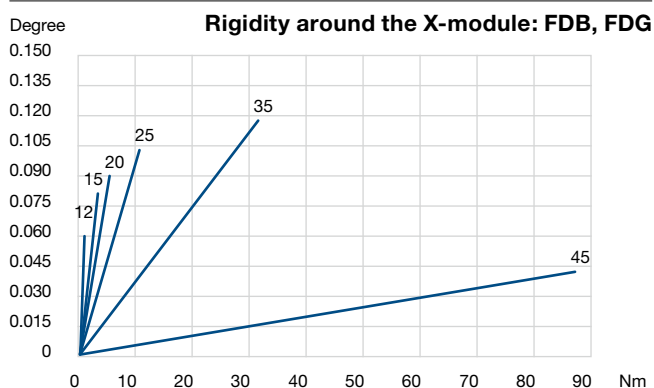
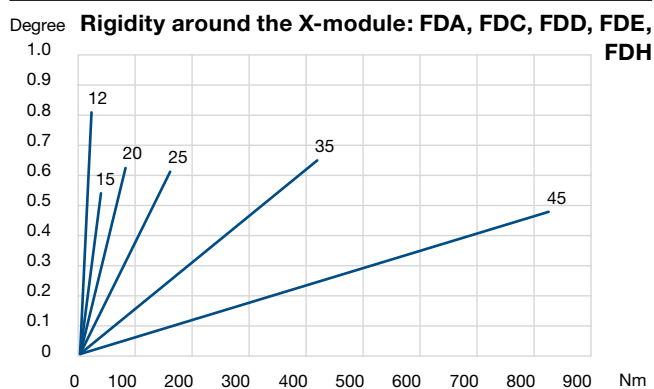
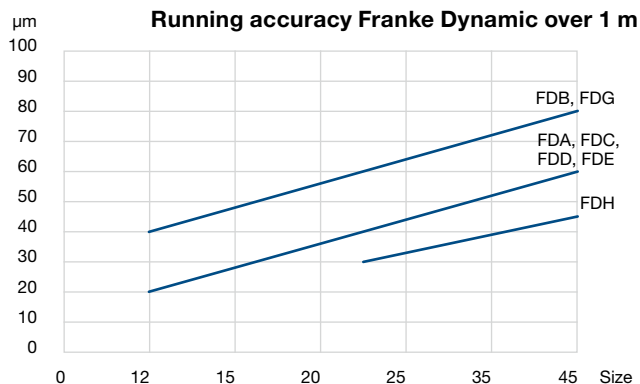

2 Linear tables/modules

2.1 Design

Uses of Franke linear tables include automation tasks in measurement and testing or to rationalize handling and assembly. The selection ranges from strokes larger than 100 mm to 7000 mm; there are spindle and belt drives. The lightweight aluminium construction, in connection with the integrated Franke guide system, permits high load ratings and moment loads. Please find precise technical data on this in the respective catalogue pages.

2.2 Area of use

We recommend using Franke Linear Systems with the safety $S \geq 3$ for simple loads without acceleration and moment loads. A safety of $S \geq 6$ should be used for dynamic moments. The mounting position is infinitely variable; we recommend an end stop or a brake for vertical operation.

The positioning accuracy of the Linear Systems type FTB is $\pm 0.025/300$ mm (IT7) as defined in the spindle pitch accuracy. Other accuracies are available on request. Repeatability is ≤ 0.01 mm. Running accuracy of the linear tables FTB is $0.02/300$ mm.

Franke rotary tables can be used in operating temperatures from -20 °C to $+80$ °C. The Linear Systems FTD 15–35 are suitable for continuous operation in temperatures of -30 °C to $+80$ °C. Please contact us if you wish to operate in a different temperature range.

2.3 Limit switch and reference switch

- Reference switch: Franke Linear Systems in series FTB are fitted with inductive proximity switches that are set to stroke end position. On request another proximity switch can be fitted as a reference switch. The linear modules FTC and FTD have the option of attaching infinitely adjustable limit switches to the outside. By standard, Franke Linear Systems are fitted with inductive limit and reference switches PNP-nc 10-30VDC. PNP-no, NPN-no and NPN-nc switches are available on request. Fitting or installing a length measurement system with sinus or square-wave signal is possible on request. Rotary encoders can be fitted to the motor.
- Multi-module units: Franke Linear Systems can be combined to produce multi-module units. The required angle and adapter plates are selected to meet your requirements. We deliver fully fitted units, wired and aligned, with additional accessories on request.
- Motorization: A large variety of stepper or servo motors can be fitted to the Linear Systems. Connecting flanges and

couplings are modified accordingly. We can also accommodate customer motors.

- Motor deflection, transmission: By standard, the motor is mounted in the extension of the stroke module. Motor deflection via toothed belt or angled gears can be fitted to suit special uses, e.g. in cramped spaces.

We are pleased to advise you here, also.

2.4 Maintenance and lubrication

Franke Linear Systems are low-maintenance and have factory-fitted lifetime lubrication. Relubrication is not necessary, apart from the ball screw. Relubrication may be necessary – depending on the use – resulting from leakage of grease via the spindle shaft. We recommend relubrication with approx. 1–2 g grease in intervals of approx. 700 operating hours. If necessary you should clean the insides and the guide tracks and coat them with grease.

Fully synthetic lubricants are best suited for long-term lubrication. In its factory Franke uses the fully synthetic, special grease ISOFLEX TOPAS NCA52 (made by Klüber). We recommend high-quality lithium soap grease on mineral oil basis as an alternative lubricant. If you intend to mix lubricants you must make sure that the types are compatible in terms of base oil type, thickener, base oil viscosity and NLGI class. Please consult with the lubricant manufacturer for extreme conditions and extraordinary operating circumstances (vacuum, radiation, high temperature).

2.5 Definitions

- Running accuracy describes the greatest possible deviation between any given point on the moved table surface from the ideal lines when travelling the entire stroke distance (provided the substructure is even).
- Positioning accuracy is the greatest possible deviation from reaching a predefined point traveled to from a previously defined zero point.
- Repeatability is the greatest possible deviation from reaching a previously defined point on multiple instances. The measurement system used defines the degree of accuracy.
- Discrimination is the smallest possible travel distance. It is dependent on the spindle pitch, the transmission, the step angle and the classification within the measurement system. Discrimination is used to neutralize faults in positioning or repetition. It must therefore always be higher than the permissible positioning accuracy.

Please observe our assembly and maintenance instructions for each item.

3 Type FTH

3.1 Design

Franke linear motor modules FTH Drive are suitable for tasks in measurement and testing, also in handling and assembly. Strokes from 200 mm to 5300 mm are available. Integrated linear motors provide the drive. The lightweight aluminium construction, based on the Franke guide system, permits high load ratings and moment loads.

3.2 Area of use

We recommend using the safety $S \geq 3$ for simple loads without acceleration and moment loads. A safety of $S \geq 6$ should be achieved for dynamic moments. The mounting position is infinitely variable; we recommend an end stop or a brake for vertical operation.

Franke linear motor modules FTH Drive can be used in operating temperatures from -20 °C to $+80\text{ °C}$. Other temperature ranges on request.

3.3 Accuracy

The positioning accuracy is $\pm 0.01\text{ mm/m}$ and is dependent on the measurement system used. Other accuracies are available on request. The repeatability is $\leq 0.02\text{ mm}$. The running accuracy is 0.04 mm/m .

3.4 Dynamism

Franke linear motor modules FTH Drive can achieve the values listed in the diagrams (page 131).

These are approximate values that are based on a horizontal feed movement in trapezoidal/delta operation. We are pleased to define the matching components for your application.

3.5 Motorization

The linear motor modules FTH Drive are driven by linear servo motors without mechanical drive components. The linear motor consists of a slide part and a guide part. The slide part houses the windings, the position recorder and the temperature gage. The drive magnets are found in the guide part.

The linear motors used are characterized by extremely high performance density (maximum dynamism with smallest possible space) and hence permit acceleration of up to 100 m/s^2 and travel speeds of up to 9 m/s .

Technical Information

Linear Systems

3.6 Control

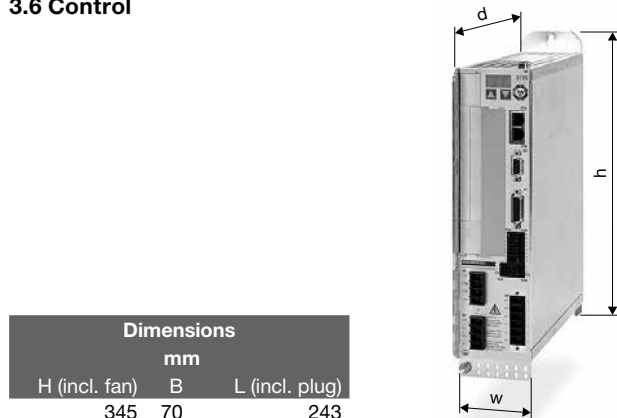

We recommend a servo amplifier S700 by the provider Kollmorgen to operate the linear motor modules FTH Drive. The S700 offers numerous special features such as the free graphic Windows® software to commission the servo amplifier. The auto-tuning function additionally facilitates commissioning. A safe torque off (STO) is fitted as standard. The S700 can load many different return systems and can evaluate up to three positioning information sets at once.

Our team of consultants will provide you with additional information, or access information on the Internet under www.kollmorgen.com.

3.7 Measurement system and limit, i.e. reference switch

By standard, Franke linear motor modules are fitted with an integrated, magnetic length measurement system. The positioning accuracy is $\pm 10 \mu\text{m}$ with discrimination of $\pm 1 \mu\text{m}$. Absolute measurement systems are available optionally.

Inductive proximity switches, infinitely positionable in the guide profile, are available to record end positions or reference positions.

3.8 Multiple module units

Linear motor modules type FTH Drive can be combined to form multi-module units. The required angle and adapter plates are selected to meet your requirements. We deliver fully fitted units, wired and aligned, with additional accessories on request.

Please observe our assembly and maintenance instructions for each item.

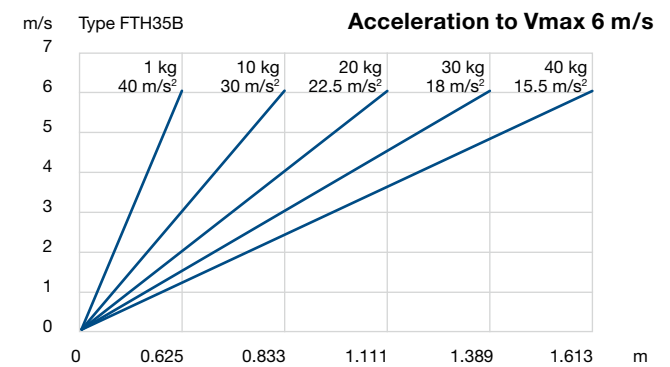
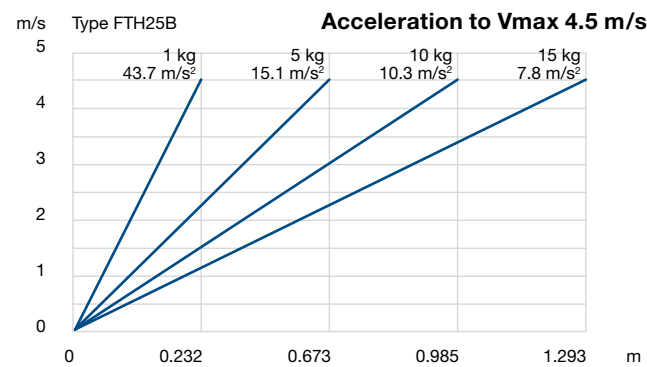
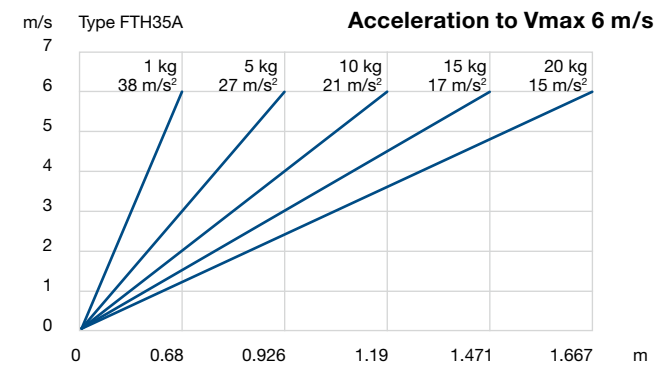
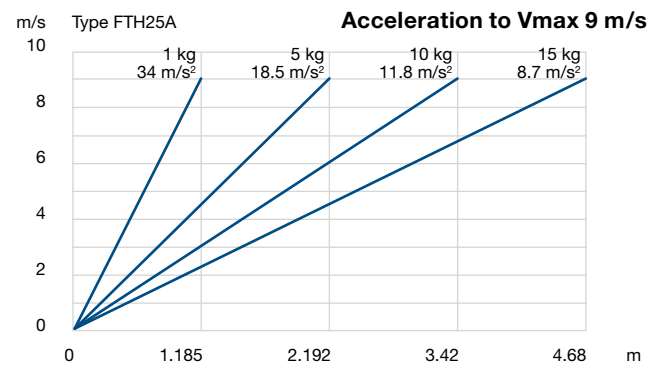
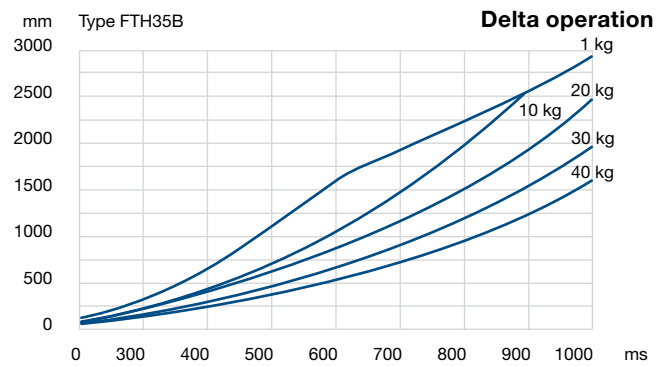
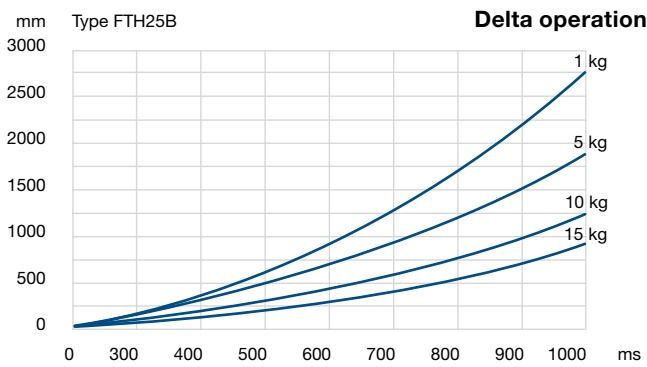
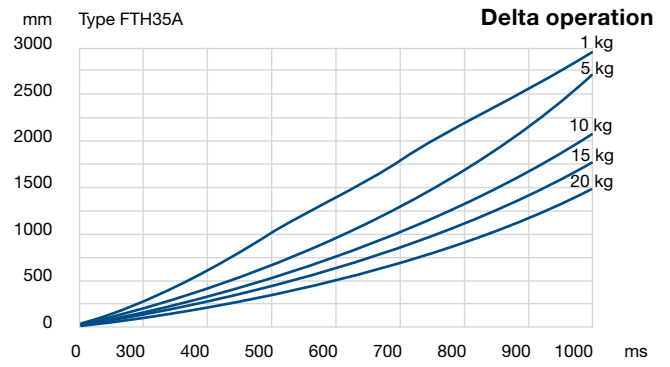
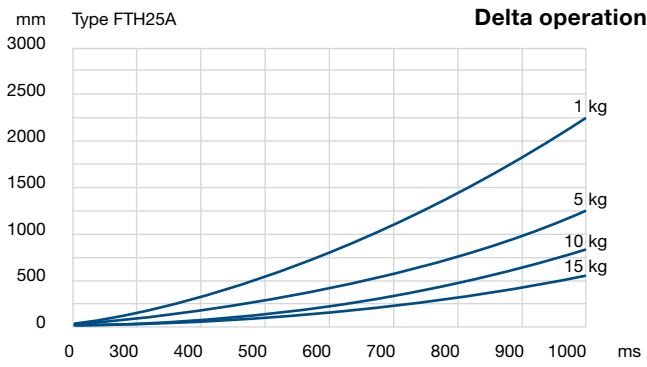



Support and consulting

Please find your contact person at Franke, on hand to assist if you have any question or need advice.



www.franke-gmbh.com



You**Tube**

XING 

Franke GmbH
Obere Bahnstraße 64
73431 Aalen, Germany
Tel. +49 7361 920-0
Fax +49 7361 920-120
info@franke-gmbh.de