



SD 500 Bearing Housings

SD 500 Bearing Housings are split plummer blocks for spherical roller bearings with adapter sleeves.

SD plummer block housings are designed for loads applied vertically to the bridging surface.

In these instances, the permissible load is determined by the load rating of the fitted bearing.

These housings have an oil well either side of the bearing, which acts as an oil bath when used with oil lubrication.

Greasing points can be added over the bearing and over labyrinth seals.

For blank shaft end applications, a blank end cover is supplied as standard, manufactured in steel.

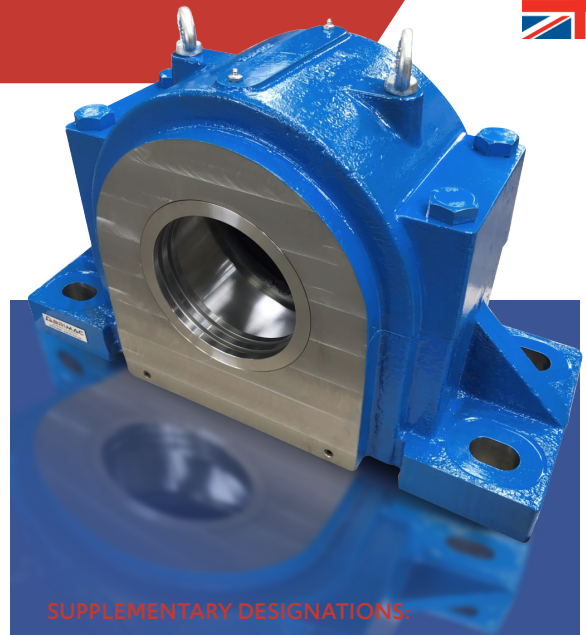

SUPPLEMENTARY DESIGNATIONS:

Housings for bearing with adapter sleeve for plain cylindrical shaft	Standard
Housings for shaft end, with end cover	A
Housings for non-locating bearing	L
Housings for locating bearing	B
Housings for locating bearing	F
Housings with labyrinth seals	TS

SEALS:

Standard labyrinth seals are supplied with these housings. However, we can also supply double row felt seals on request.

EYE BOLT:

Eyebolts are provided for heavier bearing housings.

MATERIALS:

SD housings can be supplied in following materials.

- Cast steel
- High Grade grey cast iron
- Spheroidal graphite iron (Ductile Iron)

NOTE: it is important to specify the bearing housing requirement as-

- (1) **AL** Housings for shaft end, with end cover, for non-locating bearing.
- (2) **AF** Housings for shaft end, with end cover, for locating bearing.
- (3) **BL** Housings for through shaft, for non-locating bearing.
- (4) **BF** Housings for through shaft, for locating bearing.

“BEARING HOUSING SOLUTIONS – WORLDWIDE”



SD 500 Series - Split Plummer Block Bearing Housing For spherical roller bearings with adapter sleeve.

Available in Grey Cast Iron, SG Iron or Cast Steel. To suit any seal type.

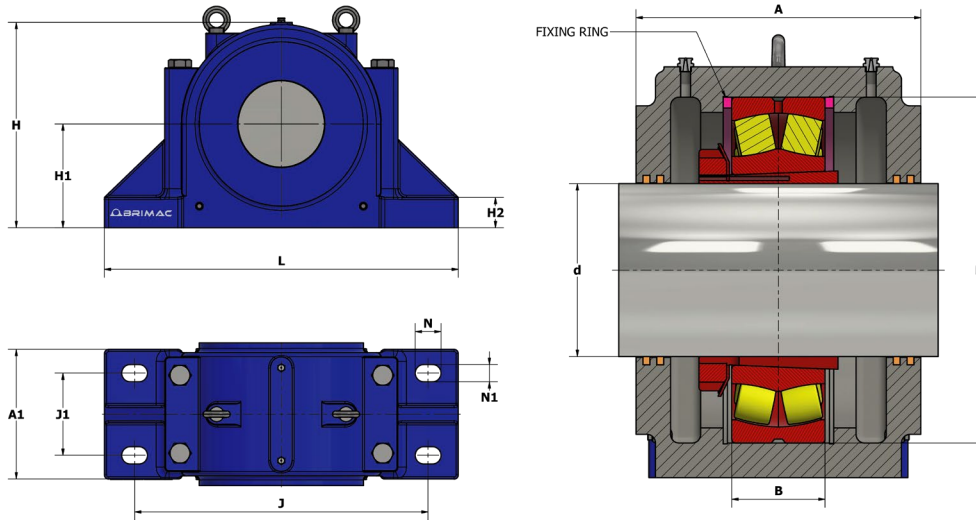

Bri-Mac Part No	Dimensions (mm)													Fixing Bolt	Weight (Kg)	Matching bearing & adapter sleeve	Matching fixing rings		Felt strip Part No.	Felt strip quantity	
	d	H	H1	A	L	A1	J1	H2	J	N1	N	D	B				Part No	Qty		Closed	Open
SD 530	135	160	320	240	550	220	120	55	450	33	45	270	73	M27	76	22230 K + H 3130	FR 270-10	2	16 x 12 x 250	4	8
SD 532	140	170	340	250	580	230	130	55	480	33	45	290	80	M27	87	22232 K + H 3132	FR 290-10	2	16 x 12 x 260	4	8
SD 534	150	180	360	270	620	250	140	60	510	36	50	310	86	M30	105	22234 K + H 3134	FR 310-10	2	16 x 12 x 275	4	8
SD 536	160	190	380	280	650	260	150	60	540	36	50	320	86	M30	118	22236 K + H 3136	FR 320-10	2	16 x 12 x 290	4	8
SD 538	170	200	400	290	700	280	160	65	570	40	55	340	92	M33	136	22238 K + H 3138	FR 340-10	2	16 x 12 x 305	4	8
SD 540	180	210	420	300	740	290	170	65	610	40	55	360	98	M33	170	22240 K + H 3140	FR 360-10	2	16 x 12 x 320	4	8
SD 544	200	240	475	330	820	320	190	70	680	42	62	400	108	M36	216	22244 K + H 3144	FR 400-10	2	16 x 12 x 350	4	8
SD 548	220	260	515	340	880	330	200	85	740	45	65	440	120	M39	258	22248 K + H 3148	FR 440-10	2	16 x 12 x 380	4	8
SD 552	240	280	555	370	940	360	210	85	790	45	65	480	130	M39	323	22252 K + H 3152	FR 480-10	2	16 x 12 x 415	4	8
SD 556	260	300	590	390	990	380	230	100	830	52	77	500	130	M45	404	22256 K + H 3156	FR 500-10	2	16 x 12 x 445	4	8
SD 560	280	325	640	410	1060	400	250	100	890	52	77	540	140	M45	480	22260 K + H 3160	FR 540-10	2	16 x 12 x 480	4	8
SD 564	300	355	690	440	1110	430	270	110	930	56	85	580	150	M48	605	22264 K + H 3164	FR 580-10	2	16 x 12 x 510	4	8

“BEARING HOUSING SOLUTIONS – WORLDWIDE”

